

External Tool Tag - User Manual (US/CA)

Product Management

Exported on 09/22/2022

Table of Contents

1	KINEXON External Tool Tag	4
2	SPECIFICATIONS	6
2.1	Mechanical Drawing	6
2.2	Label	7
2.2.1	Label back plate	7
2.2.2	Label top cover	7
2.3	External interfaces	7
2.3.1	Wireless connection	7
2.3.2	Tag LED	8
2.3.3	Electrical Parameters	8
2.4	Battery	8
3	Regulatory and Legal Information	9
3.1	Disclaimer	9
3.2	Intended Use	9
3.3	FCC Compliance	9
3.4	FCC Caution	9
3.5	ISED Caution	10
3.6	Safety Information	10

THE KINEXON External Tool Tag

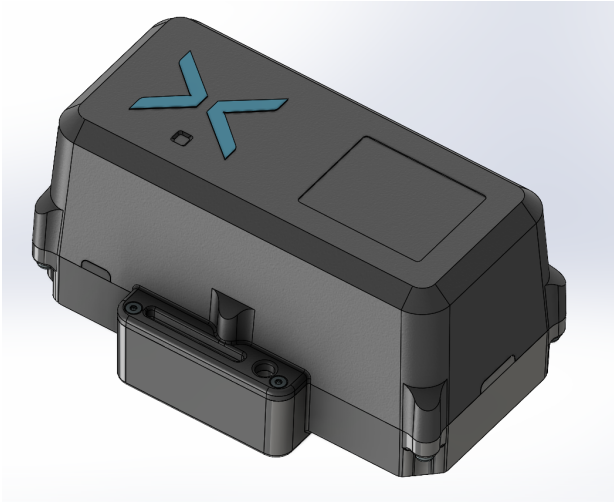

1 KINEXON External Tool Tag

Real-time localization with high update rates and long battery lifetime.

<p>The KINEXON External Tool Tag is the perfect sensor for indoor localization in industrial and logistics environments.</p> <p>By mounting or embedding the tag on the object, it enables a precise and robust localization of all assets on the shop floor. Thus, the KINEXON External Tool Tag provides the basis for track & trace of your objects, workflow monitoring and process automation.</p> <p>Due to its big battery even dynamic movements that require a high update rate can be tracked over multiple years.</p>	<p>Use Cases</p> <p>Track & Trace and optimized material handling of moving assets in industrial environments such as:</p> <ul style="list-style-type: none"> • Material & Goods • Load Carrier (Barred box, pallet etc.) • Manufactured products • Tools <p>Real-time location data is the enabler for improved process reliability and efficiency through process automation and optimization such as:</p> <ul style="list-style-type: none"> • Storage Automation • Elimination of manual scanning • Full transparency over material flow (cycle times, idle times etc.) • Process Monitoring & Process Mining
---	---

KEYFACTS

RF Specifications	
Positioning Principle	Real-time location system (RTLS, radio-based, ultra-wideband)
Frequency Range	UWB (IEEE 802.15.4a): UWB Channel 5 (6.25 - 6.75 GHz) Average EIRP < -41 dBm / 1 MHz Peak EIRP < 0 dBm / 50 MHz
Positioning Update Rate	0.01 - 20 Hz
Positioning Data	3D (x, y, z)
Positioning Accuracy	< 10 cm (depending on environment)

Physical Specifications	
Indicators	Status LED
Inertial Measurement (Accelerometer)	3-axis, +/- 0.05g to +/-16g, up to 200 Hz, typically 5Hz

Physical Specifications	
Battery	Internal non-replaceable Li primary battery
Battery Lifetime	Up to 3 years (highly dependent on configuration)
Material	
Weight	200 g
Dimensions	85 x 56 x 44 mm

Environmental Specifications	
Operating Temperature	-20°C to 60°C incl. battery
Storage Temperature	-20 °C to + 30 °C incl. battery
Cleaning	Possible to disinfect with Ethanol-containing disinfecting solutions from 40-96% of Ethanol (only surface cleaning – no immersing!) Do not use methanol, isopropanol or isopropyl alcohols for cleaning!
Water Repellent	Tag can be wiped wet with water (no immersing!)
Protection class	IP65
Regulatory compliance (pending)	<p>US: FCC Part 15 Subpart C (15.250); European Union: ETSI EN 302 065-1, ETSI EN 303 883, ETSI EN 301489-1, ETSI EN 301489-17, ETSI EN 301489-33, EN 62311, 1999/519/EC, EN 62368-1</p> <p>FCC ID: 2ALC5-KNX-HCTAG1 IC: 25557-KNXHCTAG1 ANATEL ID: XXXXX-XX-XXXXX</p>

2 SPECIFICATIONS

2.1 Mechanical Drawing

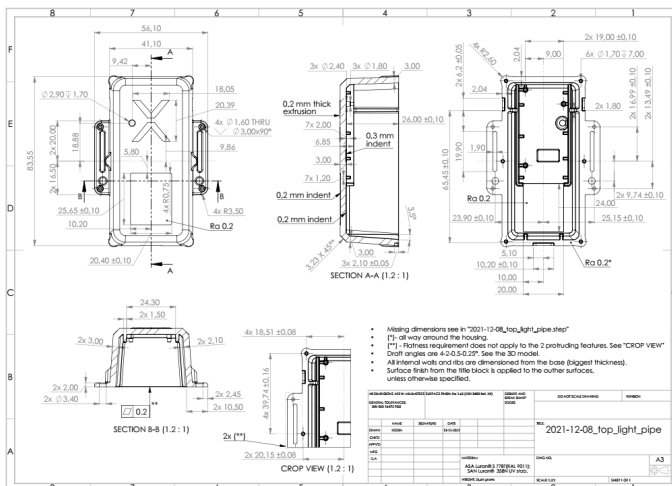
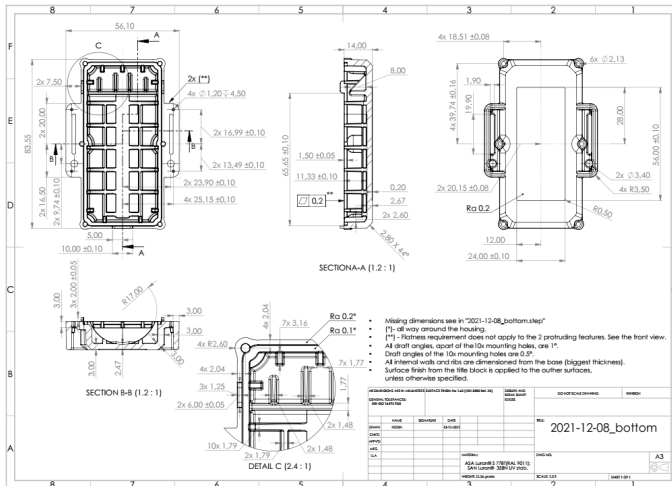

2.2 Label

2.2.1 Label back plate

<p>QR code</p> <p>EUI</p> <p>Device part-no.</p> <p>Certification logos/signs</p>	 <p>EUI: XXXXXX Model: KINX-TB-1-1.2-1 CMBIT ID: XXXXXZNNNN</p> <p>KINEXON</p>	<p>Company logo</p>
---	---	---------------------

Size: (23x 55) mm

2.2.2 Label top cover

<p>Company logo</p> <p>EUI</p> <p>QR code</p>	<p>KINEXON</p> <p>EUI: XXXXXX</p> 
---	---

Size: (20 x 25) mm

2.3 External interfaces

2.3.1 Wireless connection

For wireless connection a Ultra-Wideband (UWB) interface according to IEEE 802.15.4 is implemented.

2.3.2

Tag LED

Please mind that tag LED behavior depends on the firmware use case one has selected. Most important versions are:

Power-on Reset		
Color	Duration	Explanation
yellow	Constant, ~1s	Standstill (sleep) mode - The LED is blinking every 30 seconds for approximately 1s.
yellow	Constant, ~1s	Active mode (X-Tag in movement) - The LED is blinking every 1 second for approximately 1s.
yellow	Constant, duration depends on firmware size	Tag is being bootloaded with new firmware

2.3.3

Electrical Parameters

Interface	Parameter [Unit]	Min	Typical	Max	Comment
Power supply	Input Voltage [V]		3 V		
	Input Current [mA]			250 mA	UWB receive

2.4 Battery

A Lithium Polymer re-chargeable battery is used	
Type	CR34615
Nominal Voltage	3.0V
Capacity	12000 mAh
Operating temperature discharge	-40°C to +85°C
Size	61.5mm x 34mm x 34mm

3 Regulatory and Legal Information

The Kinexon Worker Tag has been designed to be in compliance with both the U.S. FCC Part 15 subpart F regulations, section 15.250 and with the European Union ETSI EN 302 065 standards.

3.1 Disclaimer

The information in this document is subject to change without notice. Kinexon GmbH assumes no responsibility for inaccuracies or omissions and specifically disclaims any liabilities, losses, or risks, personal or otherwise, incurred as a consequence, directly or indirectly, of the use or application of any of the contents of this document. For the latest documentation, contact Kinexon GmbH.

3.2 Intended Use

This manual describes the setup and use of the Kinexon External Tool Tag Use this product only for the purpose it was designed for.

3.3 FCC Compliance

This device complies with 47 CFR Part 15 of the FCC Rules. Operation is subject to the following two conditions: (1) This device may not cause harmful interference, and (2) this device must accept any interference received, including interference that may cause undesired operation. The user is cautioned that changes or modifications not expressly approved by the party responsible for compliance could void the user's authority to operate the equipment. This device may not be employed for the operation of toys. Operation onboard an aircraft, a ship or a satellite is prohibited. The use of this device mounted on outdoor structures, e.g., on the outside of a building or on a telephone pole, or any fixed outdoors infrastructure is prohibited.

Moreover, the following statements apply:

Note: This equipment has been tested and found to comply with the limits for a Class B digital device, pursuant to part 15 of the FCC Rules. These limits are designed to provide reasonable protection against harmful interference in a residential installation. This equipment generates, uses, and can radiate radio frequency energy and, if not installed and used in accordance with the instructions, may cause harmful interference to radio communications. However, there is no guarantee that interference will not occur in a particular installation. If this equipment does cause harmful interference to radio or television reception, which can be determined by turning the equipment off and on, the user is encouraged to try to correct the interference by one or more of the following measures:

- Reorient or relocate the receiving antenna.
- Increase the separation between the equipment and receiver.
- Connect the equipment to an outlet on a circuit different from that to which the receiver is connected.
- Consult the dealer or an experienced radio/TV technician for help.

3.4 FCC Caution

Changes or modifications not expressly approved by the party responsible for compliance could void the user's authority to operate the equipment. This device is designed not to exceed the limits for exposure to radio waves adopted by the FCC. These limits include a substantial safety margin design to assure the safety of all persons, regardless of age and health. The radio wave exposure guidelines use a unit of measurement known as the Specific Absorption Rate (SAR). SAR levels have been computed for the transmitters in this device and have been found to be below FCC limits.

3.5 ISED Caution

This device contains licence-exempt transmitter(s)/receiver(s) that comply with Innovation, Science and Economic Development Canada's licence-exempt RSS(s). Operation is subject to the following two conditions:

- (1) This device may not cause interference
- (2) This device must accept any interference, including interference that may cause undesired operation of the device.

These devices are not permitted for operation on board aircraft or satellites and shall also not be used for operating toys. The use of this device mounted on a fixed outdoor infrastructure, including antennas mounted on outdoor structures such as poles or buildings, is not permitted, except for operation on board ships or land vehicles.

Cet appareil contient des émetteurs / récepteurs exemptés de licence conformes aux RSS (RSS) d'Innovation, Sciences et Développement économique Canada. Le fonctionnement est soumis aux deux conditions suivantes:

- (1) Cet appareil ne doit pas causer d'interférences
- (2) Cet appareil doit accepter toutes les interférences, y compris celles susceptibles de provoquer un fonctionnement indésirable de l'appareil.

Les appareils ne peuvent pas être utilisés à bord d'aéronefs ou de satellites et ils ne peuvent pas être utilisés pour faire fonctionner des jouets. L'utilisation de cet appareil monté sur une infrastructure fixe d'extérieur, comprenant les antennes montées sur des structures externes telles que des poteaux ou des bâtiments, n'est pas autorisée, sauf lorsque les structures en question sont des bateaux ou des véhicules terrestres.

3.6 Safety Information

- Read and follow all instructions before using the Kinexon Worker Tag.
- Never open the case of the Kinexon Worker Tag. There are no user serviceable parts or replaceable parts inside the case.
- Do not use the Kinexon Worker Tag if it has been damaged.