

CETECOM ICT Services is now

**CTC** advanced  
member of RWTÜV group

## TEST REPORT

Test report no.: 1-2565/16-01-02



Deutsche  
Akkreditierungsstelle  
D-PL-12076-01-01

### Testing laboratory

#### CTC advanced GmbH

Untertuerkheimer Strasse 6 – 10

66117 Saarbruecken / Germany

Phone: + 49 681 5 98 - 0

Fax: + 49 681 5 98 - 9075

Internet: <http://www.ctcadvanced.com>

e-mail: [mail@ctcadvanced.com](mailto:mail@ctcadvanced.com)

#### Accredited Testing Laboratory:

The testing laboratory (area of testing) is accredited according to DIN EN ISO/IEC 17025 (2005) by the Deutsche Akkreditierungsstelle GmbH (DAkkS)

The accreditation is valid for the scope of testing procedures as stated in the accreditation certificate with the registration number: D-PL-12076-01-01

### Applicant

#### Hammer Wireless Corporation

311 Broadway

NJ08742 Point Pleasant Beach / USA

Phone:

Fax:

Contact:

e-mail:

Phone:

### Manufacturer

#### Globtel Holding d.o.o.

Panonska ulica 30

2000 Maribor, Slovenia, EU

### Test standard/s

47 CFR Part 101

Title 47 of the Code of Federal Regulations; Chapter I; Part 101 - Fixed Microwave Services

For further applied test standards please refer to section 3 of this test report.

### Test Item

**Kind of test item:** AIR PMP Base Station

**Model name:** AIR PMP BS-E-90

**FCC ID:** -/-

**Frequency:** Band 1: 27.500 GHz – 27.900 GHz

Band 2: 27.950 GHz – 28.350 GHz

**Antenna:** Integrated horn antenna, ~16 dBi

**Power supply:** 48 V DC ±10%

**Temperature range:** -40°C to +60°C



This test report is electronically signed and valid without handwriting signature. For verification of the electronic signatures, the public keys can be requested at the testing laboratory.

### Test report authorized:

Meheza Walla  
Lab Manager  
Radio Communications & EMC

### Test performed:

Karsten Gerald  
Lab Manager  
Radio Communications & EMC

## 1 Table of contents

1	Table of contents .....	2
2	General information .....	3
2.1	Notes and disclaimer .....	3
2.2	Application details.....	3
2.3	Test laboratories sub-contracted .....	3
3	Test standard/s and references .....	4
4	Test environment.....	5
5	Test item.....	5
5.1	General description.....	5
5.2	Additional information .....	5
6	Description of the test setup.....	6
6.1	Shielded fully anechoic chamber .....	7
6.2	Test laboratory: radiated measurements > 12 GHz .....	8
6.3	Test laboratory: radiated measurements > 50 GHz .....	8
6.4	Conducted measurements with power meter & spectrum analyzer .....	9
6.5	Conducted measurements under extreme conditions (frequency error).....	9
7	Sequence of testing .....	11
7.1	Sequence of testing radiated spurious 30 MHz to 1 GHz.....	11
7.2	Sequence of testing radiated spurious 1 GHz to 18 GHz .....	12
7.3	Sequence of testing radiated spurious above 18 GHz .....	13
7.4	Sequence of testing radiated spurious above 50 GHz with external mixers .....	14
8	Test results .....	15
8.1	Summary .....	15
8.2	Overview.....	16
8.3	Plots (Band 1).....	23
8.4	Plots (Band 2).....	40
Annex A	Document history .....	57
Annex B	Further information.....	57
Annex C	Accreditation Certificate .....	58

## 2 General information

### 2.1 Notes and disclaimer

The test results of this test report relate exclusively to the test item specified in this test report. CTC advanced GmbH does not assume responsibility for any conclusions and generalizations drawn from the test results with regard to other specimens or samples of the type of the equipment represented by the test item.

The test report may only be reproduced or published in full. Reproduction or publication of extracts from the report requires the prior written approval of CTC advanced GmbH.

The testing service provided by CTC advanced GmbH has been rendered under the current "General Terms and Conditions for CTC advanced GmbH".

CTC advanced GmbH will not be liable for any loss or damage resulting from false, inaccurate, inappropriate or incomplete product information provided by the customer.

Under no circumstances does the CTC advanced GmbH test report include any endorsement or warranty regarding the functionality, quality or performance of any other product or service provided.

Under no circumstances does the CTC advanced GmbH test report include or imply any product or service warranties from CTC advanced GmbH, including, without limitation, any implied warranties of merchantability, fitness for purpose, or non-infringement, all of which are expressly disclaimed by CTC advanced GmbH.

All rights and remedies regarding vendor's products and services for which CTC advanced GmbH has prepared this test report shall be provided by the party offering such products or services and not by CTC advanced GmbH.

In no case this test report can be considered as a Letter of Approval.

This test report is electronically signed and valid without handwritten signature. For verification of the electronic signatures, the public keys can be requested at the testing laboratory.

### 2.2 Application details

Date of receipt of order:	2016-08-26
Date of receipt of test item:	2016-09-26
Start of test:	2016-09-26
End of test:	2016-11-11
Person(s) present during the test:	Mr. Borut Stumberger, Mr. Sandi Kodric, Mr. Neil Berriman

### 2.3 Test laboratories sub-contracted

None

### 3 Test standard/s and references

Test standard	Date	Description
47 CFR Part 101	-/-	Title 47 of the Code of Federal Regulations; Chapter I; Part 101 - Fixed Microwave Services

Guidance	Version	Description
ANSI C63.4-2014	-/-	American national standard for methods of measurement of radio-noise emissions from low-voltage electrical and electronic equipment in the range of 9 kHz to 40 GHz

#### 4 Test environment

Temperature	: T <sub>nom</sub> T <sub>max</sub> T <sub>min</sub>	+22 °C during room temperature tests +50 °C during high temperature tests -30 °C during low temperature tests
Relative humidity content	:	55 %
Barometric pressure	:	1021 hpa
Power supply	: V <sub>nom</sub>	48 V DC ±10%

#### 5 Test item

##### 5.1 General description

Kind of test item	:	AIR PMP Base Station
Type identification	:	AIR PMP BS-E-90
S/N serial number	:	Band 1: 000831 Band 2: 000982
HW hardware status	:	GHUSADSV24
SW software status	:	GHUSAUSV24S
Frequency band TX	:	Band 1: 27.500 GHz – 27.900 GHz Band 2: 27.950 GHz – 28.350 GHz
Frequency band RX	:	Band 1/Band 2: 31.075 GHz – 31.225 GHz
Type of radio transmission	:	modulated carrier
Use of frequency spectrum	:	
Type of modulation	:	64QAM, 256QAM
Number of channels	:	66
Antenna	:	Integrated horn antenna, ~16 dBi
Power supply	:	48 V DC ±10%
Temperature range	:	-40°C to +60°C

##### 5.2 Additional information

The tested DUT is only a transceiver/booster. The modulation is usually done in an external device (CMTS-Cable Modem Termination System). For testing the DUT a signal generator was used to generate modulated signals as described by the applicant (64QAM / 5.056941 MSym/s and 256QAM / 5.360537 MSym/s).

The content of the following annexes is defined in the QA. It may be that not all of the listed annexes are necessary for this report, thus some values in between may be missing.

Test setup- and EUT-photos are included in test report:        1-2565/16-01-01\_AnnexA  
    1-2565/16-01-01\_AnnexB  
    1-2565/16-01-01\_AnnexC

## 6 Description of the test setup

Typically, the calibrations of the test apparatus are commissioned to and performed by an accredited calibration laboratory. The calibration intervals are determined in accordance with the DIN EN ISO/IEC 17025. In addition to the external calibrations, the laboratory executes comparison measurements with other calibrated test systems or effective verifications. Weekly chamber inspections and range calibrations are performed. Where possible, RF generating and signaling equipment as well as measuring receivers and analyzers are connected to an external high-precision 10 MHz reference (GPS-based or rubidium frequency standard).

In order to simplify the identification of the equipment used at some special tests, some items of test equipment and ancillaries can be provided with an identifier or number in the equipment list below (Lab/Item).

### Agenda: Kind of Calibration

k	calibration / calibrated	EK	limited calibration
ne	not required (k, ev, izw, zw not required)	zw	cyclical maintenance (external cyclical maintenance)
ev	periodic self verification	izw	internal cyclical maintenance
Ve	long-term stability recognized	g	blocked for accredited testing
vkl!	Attention: extended calibration interval		
NK!	Attention: not calibrated	*)	next calibration ordered / currently in progress

### 6.1 Shielded fully anechoic chamber

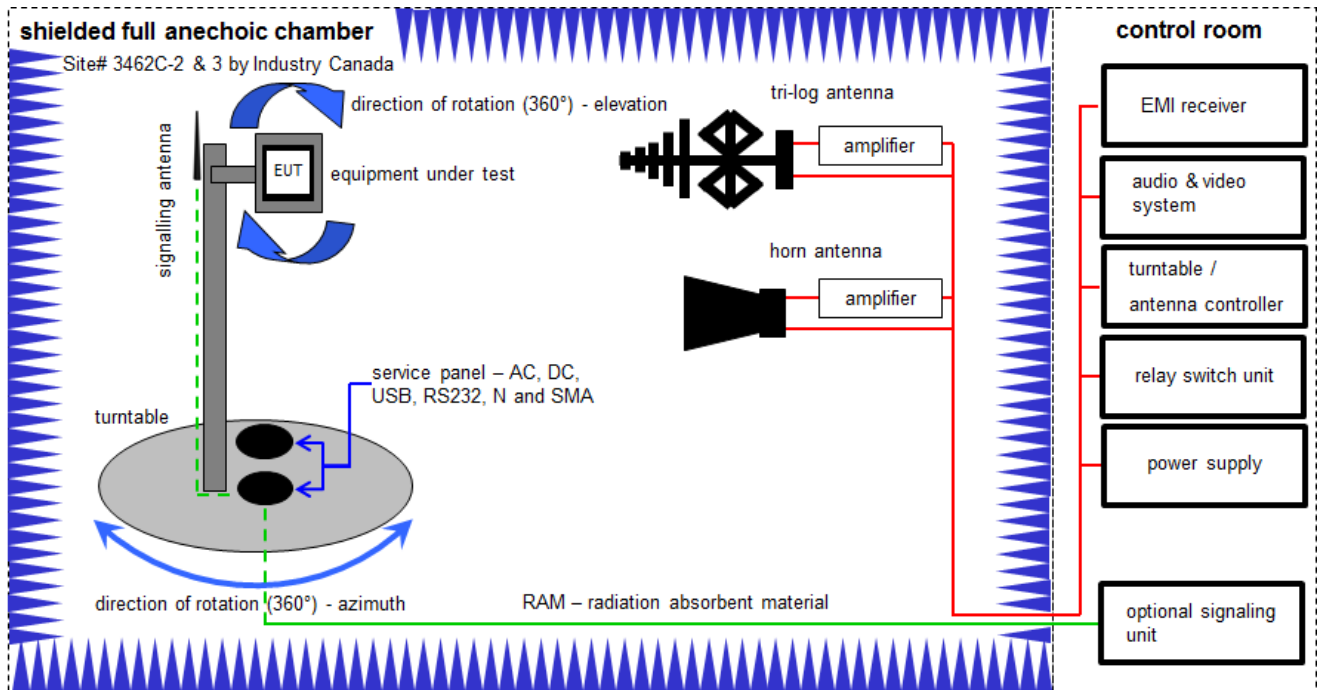

OP = AV + D - G + CA  
 (OP-radiated output power; AV-analyzer value; D-free field attenuation of measurement distance; G-antenna gain+amplifier gain; CA-loss signal path)

Example calculation:

OP [dBm] = -39.0 [dBm] + 57.0 [dB] - 12.0 [dBi] + (-36.0) [dB] = -30 [dBm] (1 µW)

**Equipment table:**

No.	Equipment	Type	Manufact.	Serial No.	INV. No CTC	Kind of Calibration	Last Calibration	Next Calibration
1	DC power supply, 60Vdc, 50A, 1200 W	6032A	HP	2818A03450	300001040	Ve	20.01.2015	20.01.2018
2	Double-Ridged Waveguide Horn Antenna 1-18.0GHz	3115	EMCO	8812-3088	300001032	vIKI!	20.05.2015	20.05.2017
3	Anechoic chamber	FAC 3/5m	MWB / TDK	87400/02	300000996	ev		
4	Switch / Control Unit	3488A	HP	*	300000199	ne		
5	Variable isolating transformer	MPL IEC625 Bus Variable isolating transformer	Erfi	91350	300001155	ne		
6	Amplifier	js42-00502650-28-5a	Parzich GMBH	928979	300003143	ne		
7	Band Reject filter	WRCG1855/1910-1835/1925-40/8SS	Wainwright	7	300003350	ev		
8	Band Reject filter	WRCG2400/2483-2375/2505-50/10SS	Wainwright	11	300003351	ev		
9	Highpass Filter	WHKX7.0/18G-8SS	Wainwright	18	300003789	ne		
10	TRIALOG Broadband Test-Antenna 30 MHz - 3 GHz	VULB9163	Schwarzbeck	371	300003854	vIKI!	29.10.2014	29.10.2017
11	Spectrum analyzer	FSV30	R&S	100763	300003950	k	03.02.2016	03.02.2017
12	Broadband Amplifier 0.5-18 GHz	CBLU5184540	CERNEX	22049	300004481	ev		
13	Broadband Amplifier 5-13 GHz	CBLU5135235	CERNEX	22010	300004491	ev		
14	4U RF Switch Platform	L4491A	Agilent Technologies	MY50000037	300004509	ne		
15	EMI Test Receiver 9kHz-26,5GHz	ESR26	R&S	101376	300005063	vIKI!	13.09.2016	13.03.2018

## 6.2 Test laboratory: radiated measurements > 12 GHz

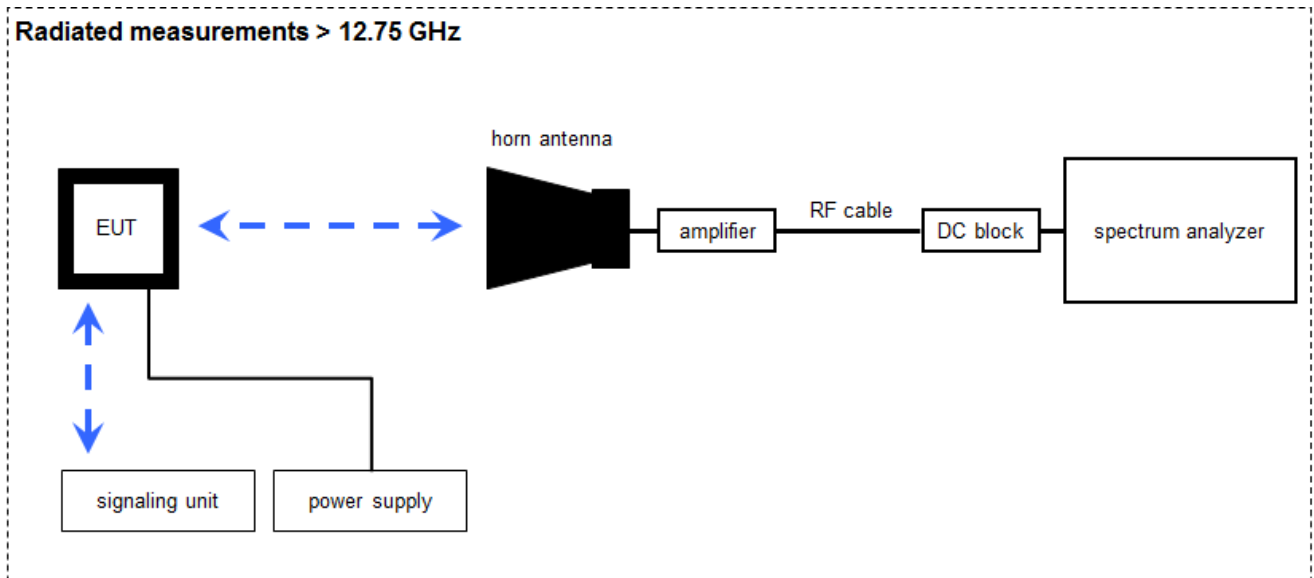

## 6.3 Test laboratory: radiated measurements > 50 GHz

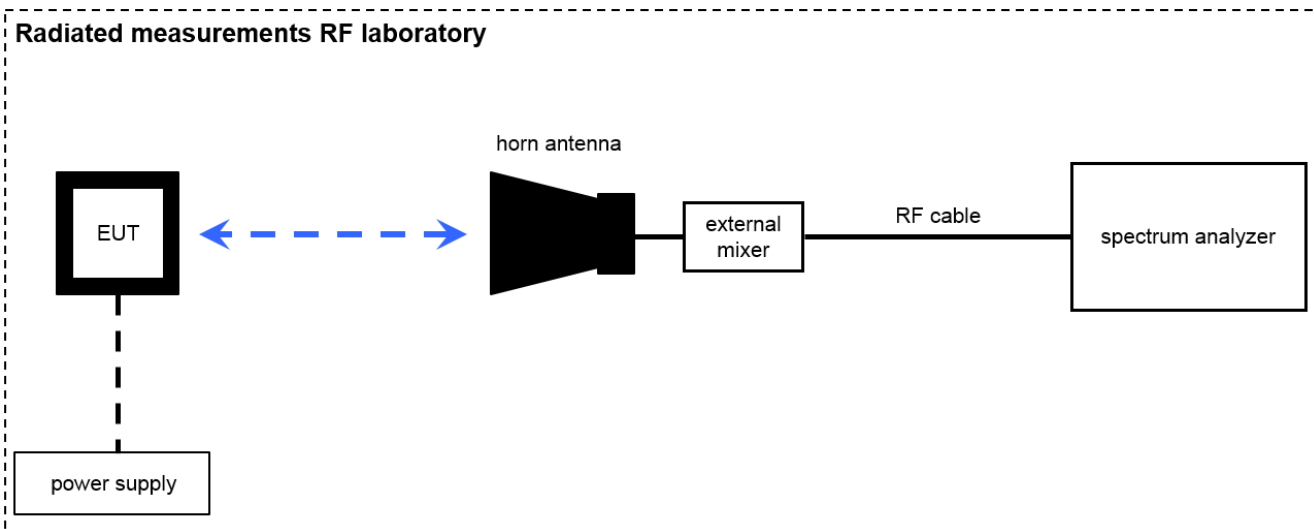

$$OP = AV + D - G$$

(OP-rad. output power; AV-analyzer value; D-free field attenuation of measurement distance; G-antenna gain)

Example calculation:

$$OP \text{ [dBm]} = -54.0 \text{ [dBm]} + 64.0 \text{ [dB]} - 20.0 \text{ [dBi]} = -10 \text{ [dBm]} \text{ (100 } \mu\text{W)}$$

Note: conversion loss of external mixer is already included in analyzer value.



## 6.4 Conducted measurements with power meter & spectrum analyzer

### Conducted measurements normal conditions

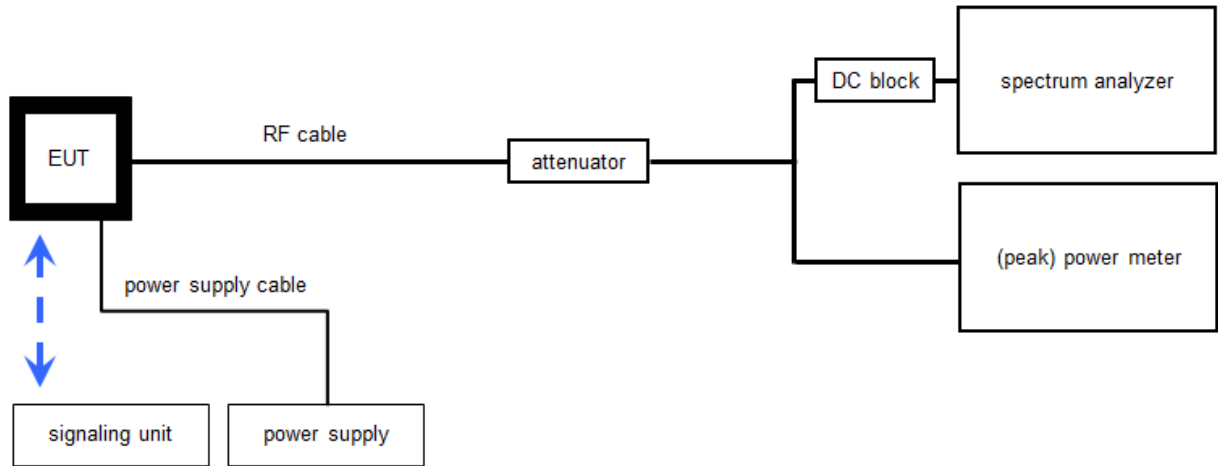

## 6.5 Conducted measurements under extreme conditions (frequency error)

### Conducted measurements normal & extreme conditions

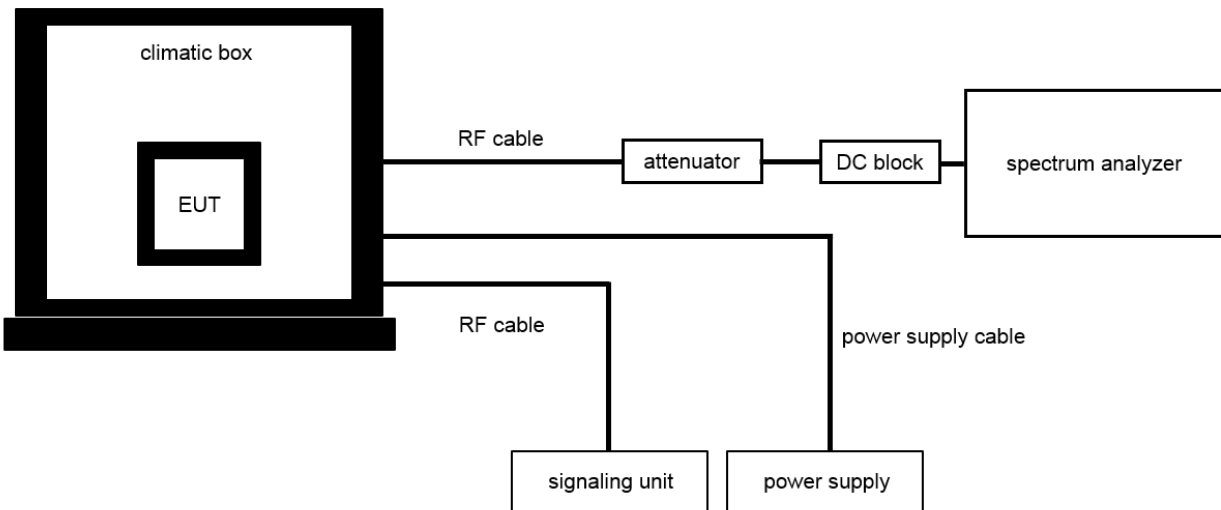

**Equipment table:**

No.	Equipment	Type	Manufact.	Serial No.	INV. No CTC	Kind of Calibration	Last Calibration	Next Calibration
1	Std. Gain Horn Antenna 49.9-75.8 GHz	2524-20	Flann	*	300001983	ne		
2	Std. Gain Horn Antenna 73.8-112 GHz	2724-20	Flann	*	300001988	ne		
3	Std. Gain Horn Antenna 12.4 to 18.0 GHz	639	Narda	8402	300000787	k	14.08.2015	14.08.2017
4	Std. Gain Horn Antenna 18.0 to 26.5 GHz	638	Narda		300000486	k	10.09.2015	10.09.2017
5	Std. Gain Horn Antenna 26.5 to 40.0 GHz	V637	Narda	82-16	300000510	k	14.08.2015	14.08.2017
6	Spectrum Analyzer 20 Hz - 50 GHz	FSU50	R&S	200012	300003443	Ve	28.10.2016	28.10.2018
7	Harmonic Mixer 2-Port, 50-75 GHz	FS-Z75	R&S	100099	300003949	k	09.03.2016	09.03.2017
8	Broadband LNA 18-50 GHz	CBL18503070PN	CERNEX	25240	300004948	ev		
9	Harmonic Mixer 3-Port, 75-110 GHz	FS-Z110	R&S	101411	300004959	k	24.10.2016	24.10.2017
10	Std. Gain Horn Antenna 110-173 GHz	2924-20	Flann	*	300001999	ne		
11	Harmonic Mixer 3-Port, 110-170 GHz	SAM-170	Radiometer Physics GmbH	100014	300004156	k	23.05.2016	23.05.2018
12	Temperature and Climatic Test Chamber	VUK04/500	Heraeus Voetsch	32678	300000297	ev	03.09.2015	03.09.2017
13	Power meter - EPM series, dual channel	E4419B	Agilent Technologies	GP39510924	300002627	viKI!	20.01.2015	20.01.2017
14	Waveguide Power Sensor, 26.5 to 40 GHz, -30 to +20	R8486A	HP	2503A00340	300000819	Ve	07.04.2016	07.04.2018
15	2m 2.4mm coax cable	SF101	H&S	3054/1	-/-	ev		
16	1.5m 2.4mm coax cable	SF101	H&S	5181/1	-/-	ev		
17	1.5m 2.4mm coax cable	SF101	H&S	5183/1	-/-	ev		

## 7 Sequence of testing

### 7.1 Sequence of testing radiated spurious 30 MHz to 1 GHz

#### Setup

- The equipment is set up to simulate normal operation mode as described in the user manual or defined by the manufacturer.
- If the EUT is a tabletop system, a table with 0.8 m height is used, which is placed on the ground plane.
- If the EUT is a floor standing device, it is placed on the ground plane with insulation between both.
- Auxiliary equipment and cables are positioned to simulate normal operation conditions as described in ANSI C 63.4.
- The AC power port of the EUT (if available) is connected to a power outlet below the turntable.
- Measurement distance is 10 m or 3 m (see ANSI C 63.4) – see test details.
- EUT is set into operation.

#### Premeasurement

- The turntable rotates from 0° to 315° using 45° steps.
- The antenna is polarized vertical and horizontal.
- The antenna height changes from 1 m to 3 m.
- At each turntable position, antenna polarization and height the analyzer sweeps three times in peak to find the maximum of all emissions.

#### Final measurement

- The final measurement is performed for at least six highest peaks according to the requirements of the ANSI C63.4.
- Based on antenna and turntable positions at which the peak values are measured the software maximize the peaks by changing turntable position  $\pm 45^\circ$  and antenna height between 1 and 4 m.
- The final measurement is done with quasi-peak detector (as described in ANSI C 63.4).
- Final levels, frequency, measuring time, bandwidth, antenna height, antenna polarization, turntable angle, correction factor, margin to the limit and limit are recorded. A plot with the graph of the premeasurement with marked maximum final results and the limit is stored.

## 7.2 Sequence of testing radiated spurious 1 GHz to 18 GHz

### Setup

- The equipment is set up to simulate normal operation mode as described in the user manual or defined by the manufacturer.
- If the EUT is a tabletop system, a 2-axis positioner with 1.5 m height is used.
- If the EUT is a floor standing device, it is placed directly on the turn table.
- Auxiliary equipment and cables are positioned to simulate normal operation conditions as described in ANSI C 63.4.
- The AC power port of the EUT (if available) is connected to a power outlet below the turntable.
- Measurement distance is 3 m (see ANSI C 63.4) – see test details.
- EUT is set into operation.

### Premeasurement

- The turntable rotates from 0° to 315° using 45° steps.
- The antenna is polarized vertical and horizontal.
- The antenna height is 1.5 m.
- At each turntable position and antenna polarization the analyzer sweeps with positive peak detector to find the maximum of all emissions.

### Final measurement

- The final measurement is performed for at least six highest peaks according to the requirements of the ANSI C63.4.
- Based on antenna and turntable positions at which the peak values are measured the software maximizes the peaks by rotating the turntable from 0° to 360°. This measurement is repeated for different EUT-table positions (0° to 150° in 30°-steps) and for both antenna polarizations.
- The final measurement is done in the position (turntable, EUT-table and antenna polarization) causing the highest emissions with Peak and RMS detector (as described in ANSI C 63.4).
- Final levels, frequency, measuring time, bandwidth, turntable position, EUT-table position, antenna polarization, correction factor, margin to the limit and limit are recorded. A plot with the graph of the premeasurement with marked maximum final results and the limit is stored.

### 7.3 Sequence of testing radiated spurious above 18 GHz

#### Setup

- The equipment is set up to simulate normal operation mode as described in the user manual or defined by the manufacturer.
- Auxiliary equipment and cables are positioned to simulate normal operation conditions as described in ANSI C 63.4.
- The AC power port of the EUT (if available) is connected to a power outlet.
- The measurement distance is as appropriate (e.g. 0.5 m).
- The EUT is set into operation.

#### Premeasurement

- The test antenna is handheld and moved carefully over the EUT to cover the EUT's whole sphere and different polarizations of the antenna.

#### Final measurement

- The final measurement is performed at the position and antenna orientation causing the highest emissions with Peak and RMS detector (as described in ANSI C 63.4).
- Final levels, frequency, measuring time, bandwidth, correction factor, margin to the limit and limit are recorded. A plot with the graph of the premeasurement and the limit is stored.

## 7.4 Sequence of testing radiated spurious above 50 GHz with external mixers

### Setup

- The equipment is set up to simulate normal operation mode as described in the user manual or defined by the manufacturer.
- Auxiliary equipment and cables are positioned to simulate normal operation conditions as described in ANSI C 63.4.
- The AC power port of the EUT (if available) is connected to a power outlet.
- The measurement distance is as appropriate for far field (e.g. 0.25 m).
- The EUT is set into operation.

### Premeasurement

- The test antenna with external mixer is handheld and moved carefully over the EUT to cover the EUT's whole sphere and different polarizations of the antenna.
- Caution is taken to reduce the possible overloading of the external mixer.

### Final measurement

- The final measurement is performed at the position and antenna orientation causing the highest emissions with Peak and RMS detector (as described in ANSI C 63.4).
- As external mixers may generate false images care is taken to ensure that any emission measured by the spectrum analyzer does indeed originate in the EUT. Signal identification feature of spectrum analyzer is used to eliminate false mixer images (i.e., it is not the fundamental emission or a harmonic falling precisely at the measured frequency).
- Final levels, frequency, measuring time, bandwidth, correction factor, margin to the limit and limit are recorded. A plot with the graph of the premeasurement and the limit is stored.

## 8 Test results

### 8.1 Summary

<input checked="" type="checkbox"/>	No deviations from the technical specifications were ascertained
<input type="checkbox"/>	There were deviations from the technical specifications ascertained
<input type="checkbox"/>	This test report is only a partial test report. The content and verdict of the performed test cases are listed below.

TC identifier	Description	Verdict	Date	Remark
RF-Testing	FCC 47 CFR Part 2, 101	see table!	2016-12-13	-/-

Test Specification Clause	Test Case	Pass	Fail	NA	NP	Results
§2.1046 / §101.113	Transmitter characteristics (RF output power / maximum EIRP / PSD)	X				complies
§2.1049 / §101.109, 147	Occupied bandwidth / Spectral efficiency	X				complies
§2.1051 / §101.111	Emission limits - conducted (RF spectrum mask)	X				complies
§2.1051 / §101.111	Emission limits - conducted (conducted spurious emissions)	X				complies
§2.1053 / §101.111	Emission limits - radiated (radiated spurious emissions)	X				complies
§2.1055 / §101.107	Transmitter frequency stability	X				complies

**Note:**

NA = Not applicable; NP = Not performed

## 8.2 Overview

I.	Transmitter characteristic (R output power / maximum EIRP / maximum PSD).....	17
II.	Occupied bandwidth / Spectral efficiency .....	18
III.	Emission limits – conducted (RF spectrum mask) .....	19
IV.	Emissions limits – conducted (conducted spurious emissions) .....	20
V.	Emissions limits – radiated (radiated spurious emissions) .....	21
VI.	Transmitter frequency stability .....	22



## I. Transmitter characteristic (RF output power / maximum EIRP / maximum PSD)

Measurement conditions:

Frequency                    f                    = see table  
 Modulation                M                    = see table  
 Channel spacing        CS                    = 6 MHz  
 Temperature            t                    = +22 °C  
 Power supply            U<sub>DC</sub>                = 48 V  
 Measurement at        C'

Test set-up: 6.4

Limit: §101.113 Transmitter power limitations  
 max. EIRP: 55 dBW (85 dBm)  
 max. PSD: 42 dBW / 1 MHz

Measurement result:

Frequency Band	Frequency [ GHz ]	Modulation	RF Power [ dBm ]	EIRP [ dBm ]
Band 1	27.504	64QAM	15.0	31.0
Band 1	27.702	64QAM	15.0	31.0
Band 1	27.894	64QAM	15.0	31.0
Band 1	27.504	256QAM	15.0	31.0
Band 1	27.702	256QAM	15.0	31.0
Band 1	27.894	256QAM	15.0	31.0
Band 2	27.954	64QAM	15.0	31.0
Band 2	28.152	64QAM	15.0	31.0
Band 2	28.344	64QAM	15.0	31.0
Band 2	27.954	256QAM	15.0	31.0
Band 2	28.152	256QAM	15.0	31.0
Band 2	28.344	256QAM	15.0	31.0

Antenna Information		
Type designation	Product Number	Nominal Gain (dBi)
Band 1 / Band 2	27,9GHz VP70-WR34 AIR 02-0390	16.0

**Result:** The measurement is passed.

## II. Occupied bandwidth / Spectral efficiency

Measurement conditions:

Frequency	f	= see table
Modulation	M	= see table
Channel spacing	CS	= 6 MHz
Temperature	t	= +22 °C
Power supply	U <sub>DC</sub>	= 48 V
Measurement at	C'	

Test set-up: no. 6.4

Limit: §101.109(c) Bandwidth  
 max. 850 MHz

Measurement result:

Frequency Band	Frequency [ GHz ]	Modulation	Occupied bandwidth [ MHz ]	Plot No.
Band 1	27.504	64QAM	5.895	A.1
Band 1	27.702	64QAM	5.895	A.2
Band 1	27.894	64QAM	5.895	A.3
Band 1	27.504	256QAM	<b>6.255</b>	A.12
Band 1	27.702	256QAM	6.240	A.13
Band 1	27.894	256QAM	6.240	A.14
Band 2	27.954	64QAM	5.895	B.1
Band 2	28.152	64QAM	5.895	B.2
Band 2	28.344	64QAM	5.895	B.3
Band 2	27.954	256QAM	6.250	B.12
Band 2	28.152	256QAM	<b>6.255</b>	B.13
Band 2	28.344	256QAM	<b>6.255</b>	B.14

**Result:** The measurement is passed.

### III. Emission limits – conducted (RF spectrum mask)

Measurement conditions:

Frequency                    f                    = see table  
 Modulation                M                    = see table  
 Channel spacing        CS                    = 6 MHz  
 Temperature            t                    = +22 °C  
 Power supply            U<sub>DC</sub>                = 48 V  
 Measurement at        C'

Test set-up:    no. 6.4

Limit:            §101.111 Emission limitations  
 see plots

Measurement result:

Frequency Band	Frequency [ GHz ]	Modulation	Plot No.
Band 1	27.504	64QAM	A.4
Band 1	27.702	64QAM	A.5
Band 1	27.894	64QAM	A.6
Band 1	27.504	256QAM	A.15
Band 1	27.702	256QAM	A.16
Band 1	27.894	256QAM	A.17
Band 2	27.954	64QAM	B.4
Band 2	28.152	64QAM	B.5
Band 2	28.344	64QAM	B.6
Band 2	27.954	256QAM	B.15
Band 2	28.152	256QAM	B.16
Band 2	28.344	256QAM	B.17

**Result:** The measurement is passed.

#### IV. Emissions limits – conducted (conducted spurious emissions)

Measurement conditions:

Frequency                      f                      = low / mid / high  
 Modulation                    M                      = see table  
 Channel spacing              CS                      = 6 MHz  
 Temperature                  t                      = +22 °C  
 Power supply                  U<sub>DC</sub>                   = 48 V  
 Measurement at                C'

Test set-up:    no. 6.4

Limit:                    §101.111 Emission limitations  
                               -13 dBm

Measurement result:

Frequency Band / Modulation	Frequency Range [ GHz ]	Limit [ dBm ]	Res. BW [ MHz ]	Spurious [ GHz ]	Emissions [ dBm ]	Plot No.
Band 1, 64QAM	15.0 - 40.0	-13.0	1.0	n.f.	< limit	A.7
Band 1, 64QAM	40.0 - 50.0	-13.0	1.0	n.f.	< limit	A.8
Band 1, 64QAM	50.0 - 75.0	-13.0	1.0	n.f.	< limit	A.9
Band 1, 64QAM	75.0 - 110.0	-13.0	1.0	n.f.	< limit	A.10
Band 1, 64QAM	110.0 - 170.0	-13.0	1.0	n.f.	< limit	A.11
Band 1, 256QAM	15.0 - 40.0	-13.0	1.0	n.f.	< limit	A.18
Band 1, 256QAM	40.0 - 50.0	-13.0	1.0	n.f.	< limit	A.19
Band 1, 256QAM	50.0 - 75.0	-13.0	1.0	n.f.	< limit	A.20
Band 1, 256QAM	75.0 - 110.0	-13.0	1.0	n.f.	< limit	A.21
Band 1, 256QAM	110.0 - 170.0	-13.0	1.0	n.f.	< limit	A.22
Band 2, 64QAM	15.0 - 40.0	-13.0	1.0	n.f.	< limit	B.7
Band 2, 64QAM	40.0 - 50.0	-13.0	1.0	n.f.	< limit	B.8
Band 2, 64QAM	50.0 - 75.0	-13.0	1.0	n.f.	< limit	B.9
Band 2, 64QAM	75.0 - 110.0	-13.0	1.0	n.f.	< limit	B.10
Band 2, 64QAM	110.0 - 170.0	-13.0	1.0	n.f.	< limit	B.11
Band 2, 256QAM	15.0 - 40.0	-13.0	1.0	n.f.	< limit	B.18
Band 2, 256QAM	40.0 - 50.0	-13.0	1.0	n.f.	< limit	B.19
Band 2, 256QAM	50.0 - 75.0	-13.0	1.0	n.f.	< limit	B.20
Band 2, 256QAM	75.0 - 110.0	-13.0	1.0	n.f.	< limit	B.21
Band 2, 256QAM	110.0 - 170.0	-13.0	1.0	n.f.	< limit	B.22

n.f. = nothing found

**Result:** The measurement is passed.

## V. Emissions limits – radiated (radiated spurious emissions)

Measurement conditions:

Frequency  $f_{mid}$  = 83.500 GHz  
 Modulation M = 4QAM  
 Channel spacing CS = 250 MHz  
 Temperature t = +22 °C  
 Power supply  $U_{DC}$  = 48 V  
 Measurement at C'

Test set-up: 6.1 – 6.3

Limit: §101.111 Emission limitations  
 -13 dBm

Measurement result:

Frequency Band	Frequency Range [ GHz ]	Limit [ dBm ]	Res. BW [ MHz ]	Spurious [ GHz ]	Level [ dBm ]	Plot No.
Band 1	0.03 - 1.0	-13.0	1.0	n.f.	< limit	A.23
Band 1	1.0 - 12.75	-13.0	1.0	n.f.	< limit	A.24
Band 1	12.5 - 18.0	-13.0	1.0	n.f.	< limit	A.25
Band 1	18.0 - 26.5	-13.0	1.0	n.f.	< limit	A.26
Band 1	26.5 - 40.0	-13.0	1.0	n.f.	< limit	A.27
Band 1	40.0 - 50.0	-13.0	1.0	n.f.	< limit	A.28
Band 1	50.0 - 75.0	-13.0	1.0	n.f.	< limit	A.29
Band 1	75.0 - 110.0	-13.0	1.0	n.f.	< limit	A.30
Band 1	110.0 - 170.0	-13.0	1.0	n.f.	< limit	A.31
Band 2	0.03 - 1.0	-13.0	1.0	n.f.	< limit	B.23
Band 2	1.0 - 12.75	-13.0	1.0	n.f.	< limit	B.24
Band 2	12.5 - 18.0	-13.0	1.0	n.f.	< limit	B.25
Band 2	18.0 - 26.5	-13.0	1.0	n.f.	< limit	B.26
Band 2	26.5 - 40.0	-13.0	1.0	n.f.	< limit	B.27
Band 2	40.0 - 50.0	-13.0	1.0	n.f.	< limit	B.28
Band 2	50.0 - 75.0	-13.0	1.0	n.f.	< limit	B.29
Band 2	75.0 - 110.0	-13.0	1.0	n.f.	< limit	B.30
Band 2	110.0 - 170.0	-13.0	1.0	n.f.	< limit	B.31

n.f. = nothing found

**Result: The measurement is passed.**

## VI. Transmitter frequency stability

Measurement conditions:

Frequency	f	= see table
Modulation	M	= off
Channel spacing	CS	= 250 MHz
Temperature	t	= +22 °C
Power supply	U <sub>DC</sub>	= 48 V
Measurement at	C'	

Test set-up: no. 6.5

Limit: §101.107 Frequency tolerance  
 0.001% / 10 ppm

Measurement result:

U <sub>DC</sub>	Temperature	nominal frequency	measured frequency	Difference
[ V ]	[ °C ]	[ GHz ]	[ GHz ]	[ ppm ]
48	-30	27.702	27.702	0.000
48	-20	27.702	27.702	0.000
48	-10	27.702	27.702	0.000
48	0	27.702	27.702	0.000
48	+10	27.702	27.702	0.000
48	+20	27.702	27.702	0.000
48	+30	27.702	27.702	0.000
48	+40	27.702	27.702	0.000
48	+50	27.702	27.702	0.000

U <sub>DC</sub>	Temperature	nominal frequency	measured frequency	Difference
[ V ]	[ °C ]	[ GHz ]	[ GHz ]	[ ppm ]
-48	-30	28.152	28.152	0.000
-48	-20	28.152	28.152	0.000
-48	-10	28.152	28.152	0.000
-48	0	28.152	28.152	0.000
-48	+10	28.152	28.152	0.000
-48	+20	28.152	28.152	0.000
-48	+30	28.152	28.152	0.000
-48	+40	28.152	28.152	0.000
-48	+50	28.152	28.152	0.000

Note: Signal generator and spectrum analyzer were connected to external 10 MHz GPS reference during test.

**Result:** The measurement is passed.

### 8.3 Plots (Band 1)

Plot No. A.1: 64QAM

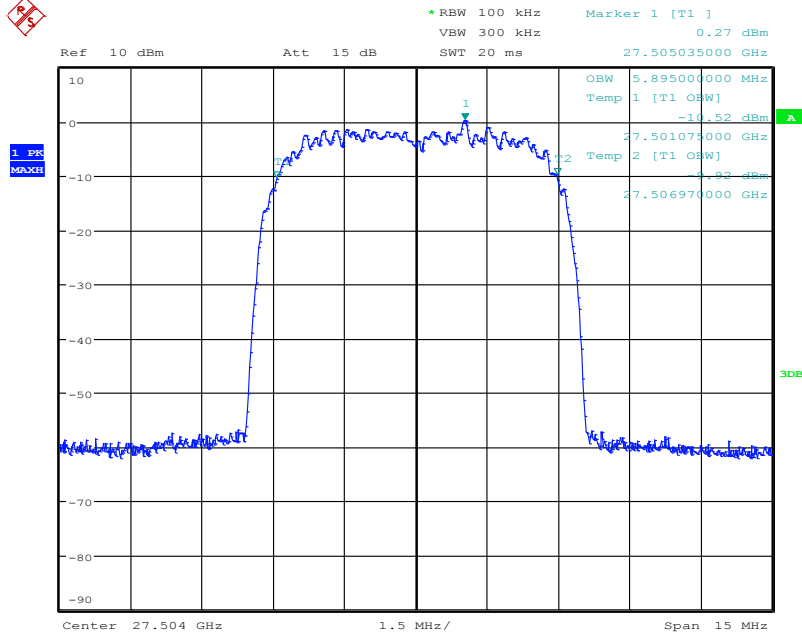

Date: 26.SEP.2016 15:13:57

Plot No. A.2: 64QAM

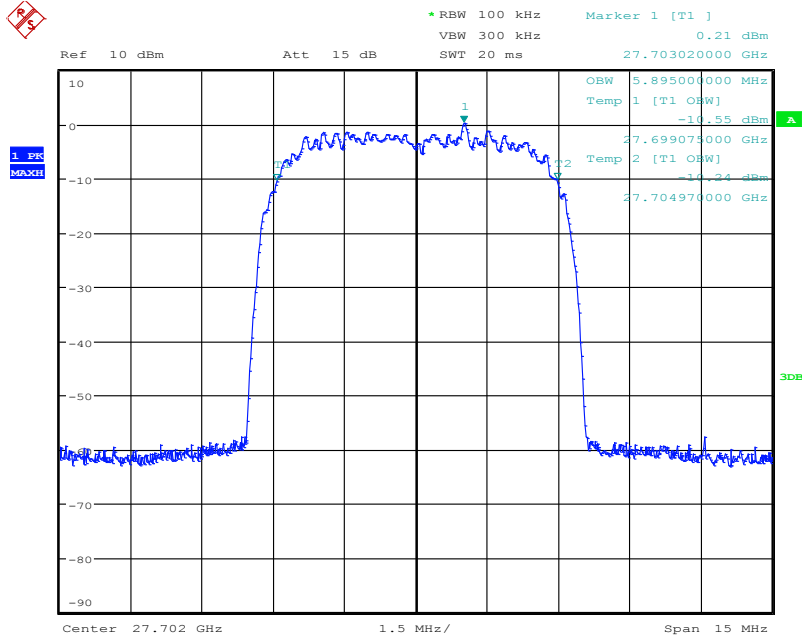

Date: 26.SEP.2016 15:13:03

Plot No. A.3: 64QAM

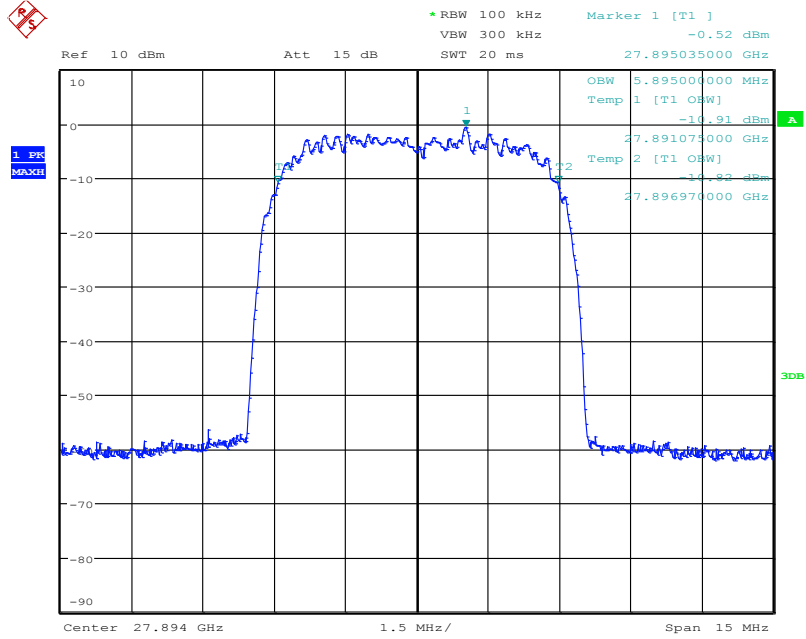

Date: 26.SEP.2016 15:11:40

Plot No. A.4: 64QAM

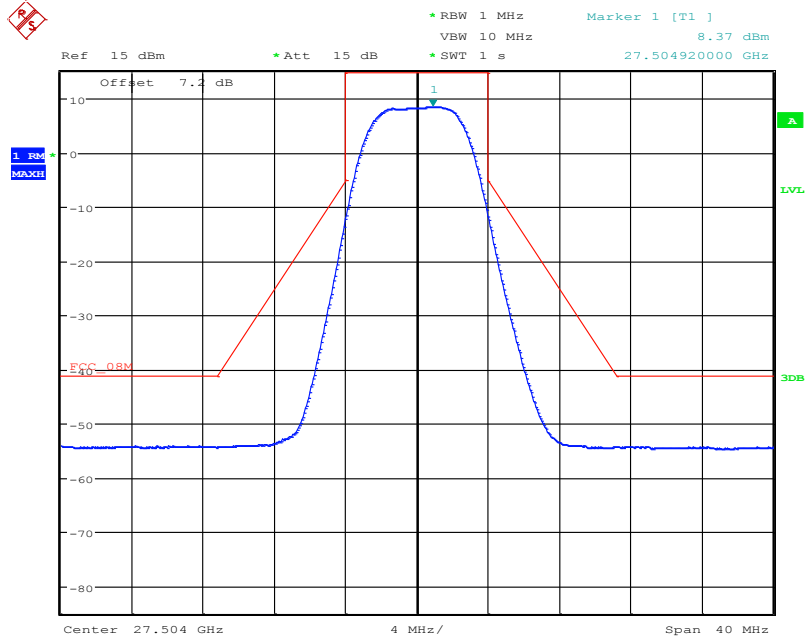

Date: 26.SEP.2016 17:03:07



Plot No. A.5: 64QAM

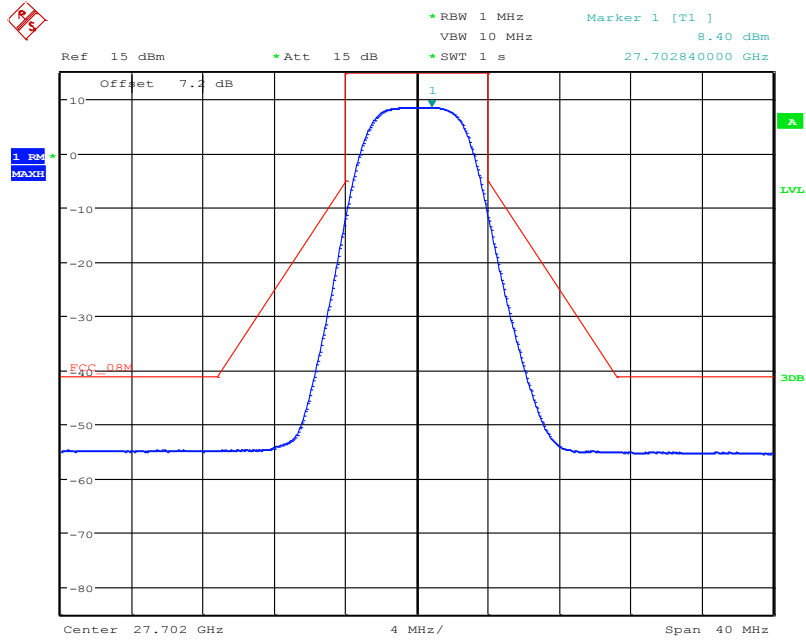

Date: 26.SEP.2016 17:02:28

Plot No. A.6: 64QAM

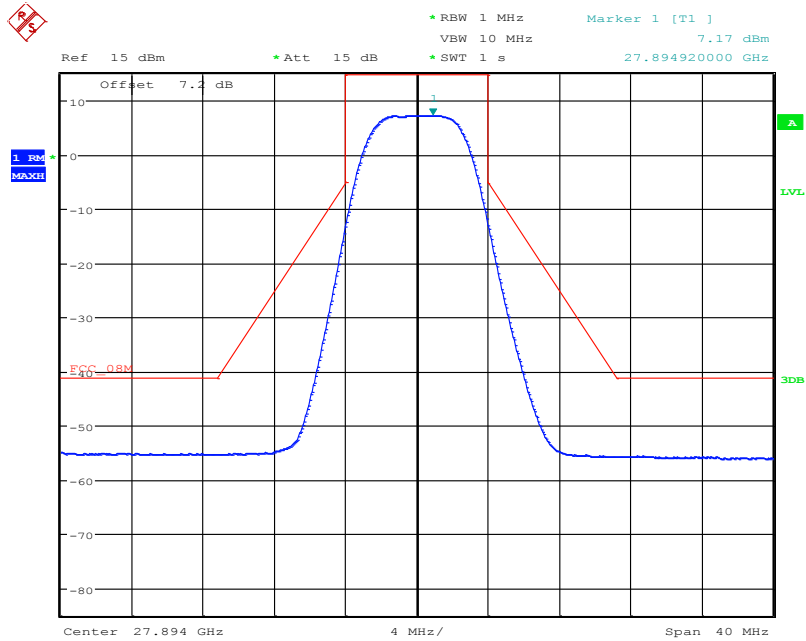

Date: 26.SEP.2016 17:01:43

Plot No. A.7: 64QAM

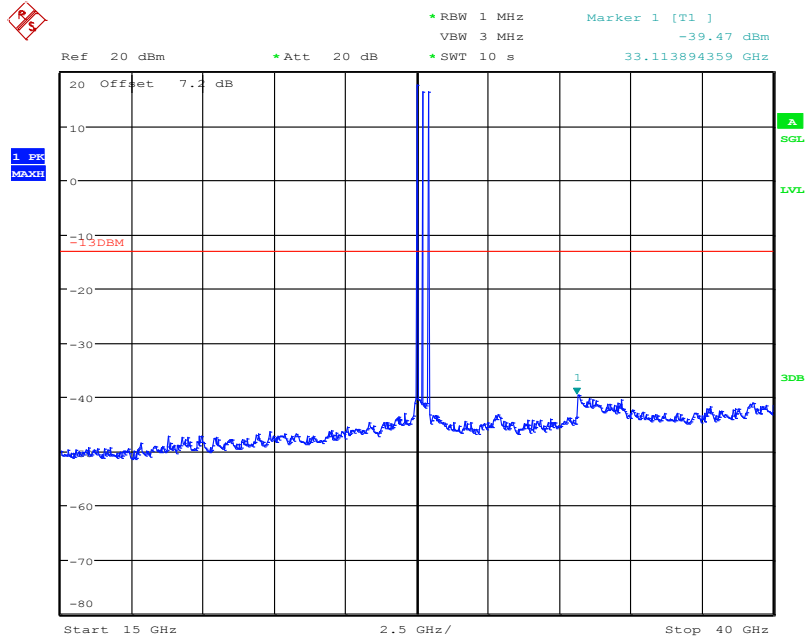

Date: 26.SEP.2016 17:11:43

**Note:** Plot shows wanted signals (low/mid/high).

Plot No. A.8: 64QAM

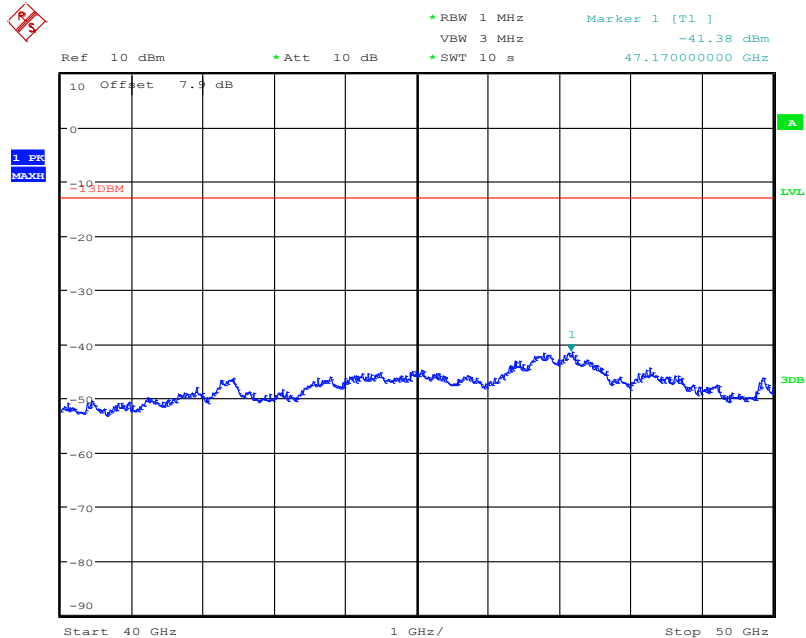

Date: 27.SEP.2016 08:44:45

Plot No. A.9: 64QAM

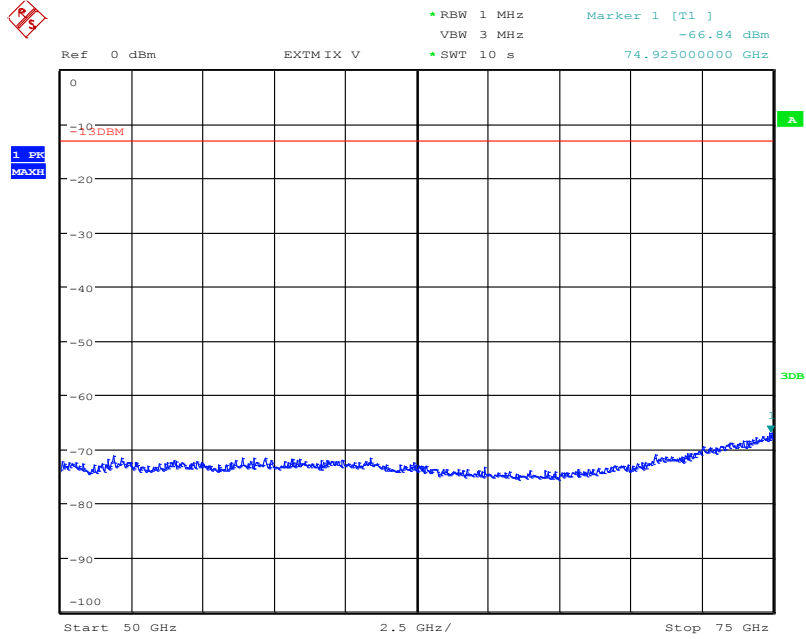

Date: 27.SEP.2016 09:56:42

Plot No. A.10: 64QAM

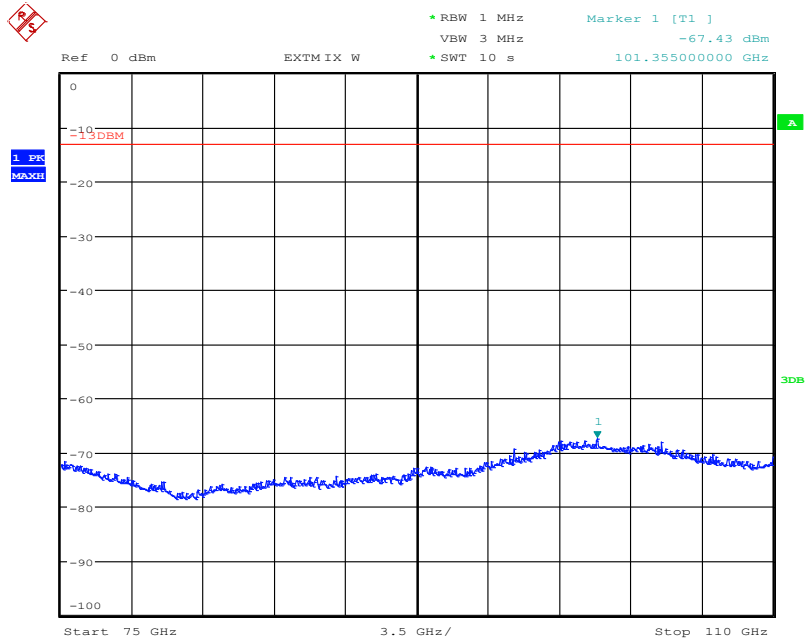

Date: 27.SEP.2016 10:26:55

Plot No. A.11: 64QAM

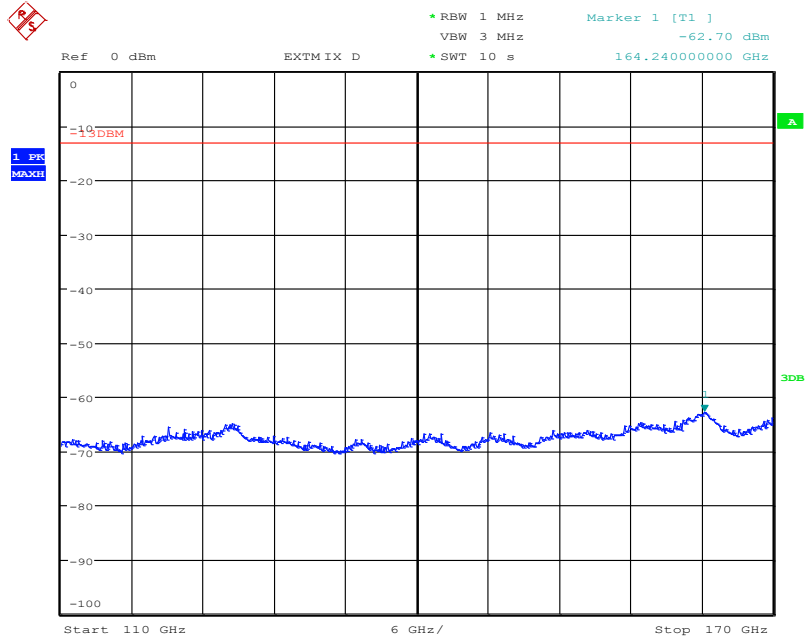

Date: 27.SEP.2016 10:41:32

Plot No. A.12: 256QAM

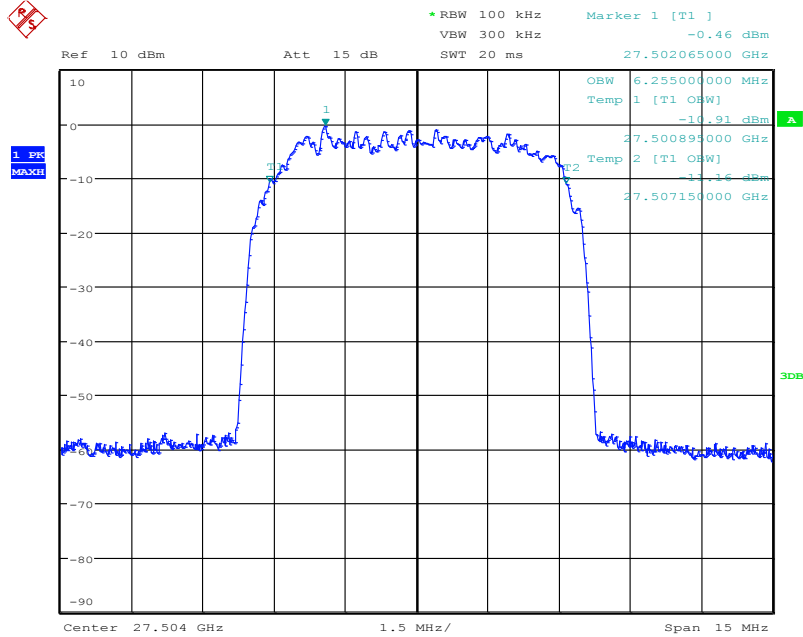

Date: 26.SEP.2016 15:15:10

Plot No. A.13: 256QAM

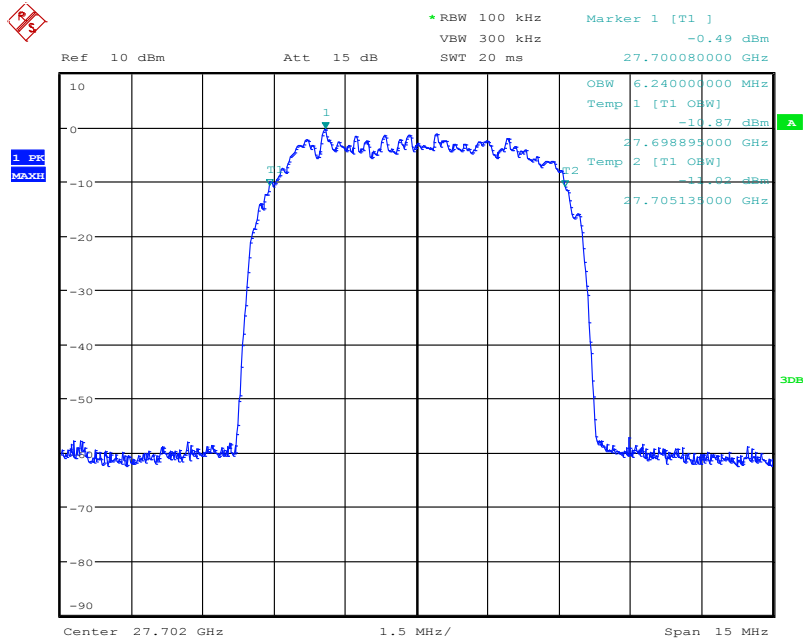

Date: 26.SEP.2016 15:15:56

Plot No. A.14: 256QAM

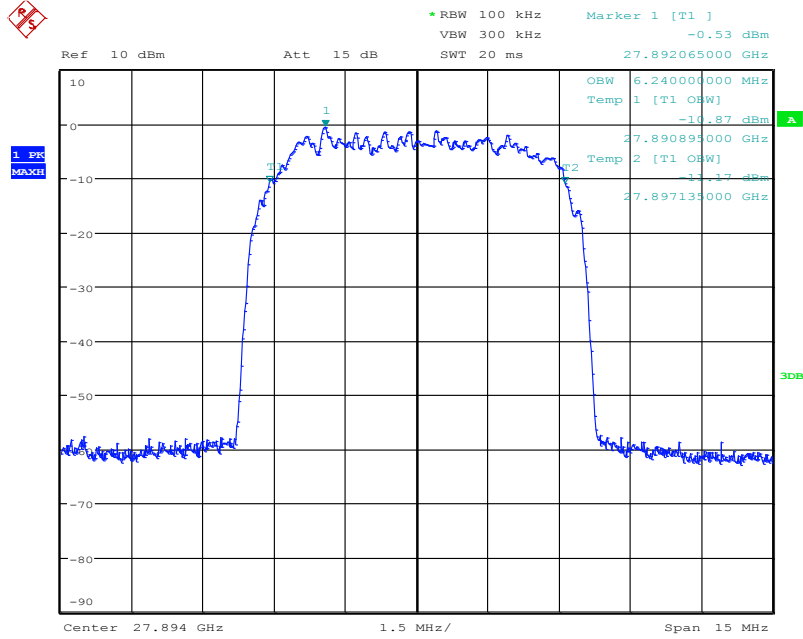

Date: 26.SEP.2016 15:16:40

Plot No. A.15: 256QAM

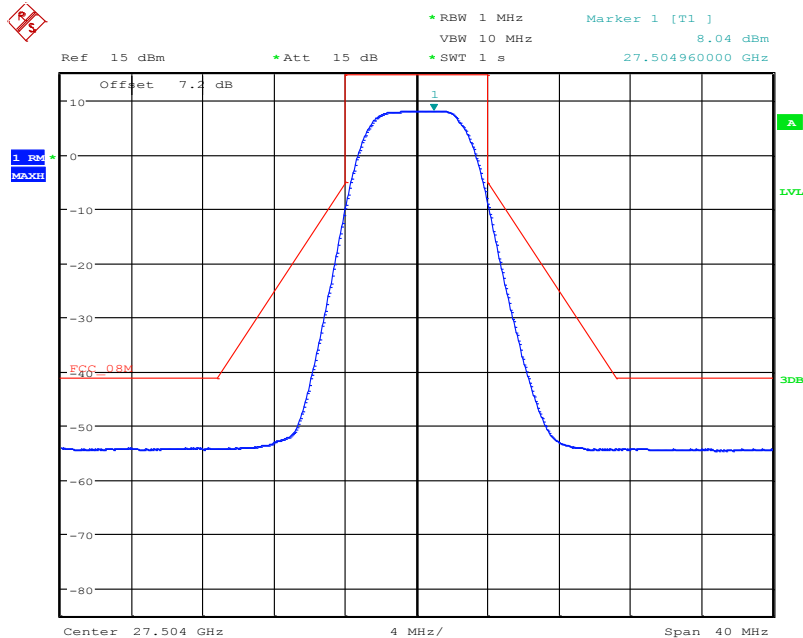

Date: 26.SEP.2016 16:59:07

Plot No. A.16: 256QAM

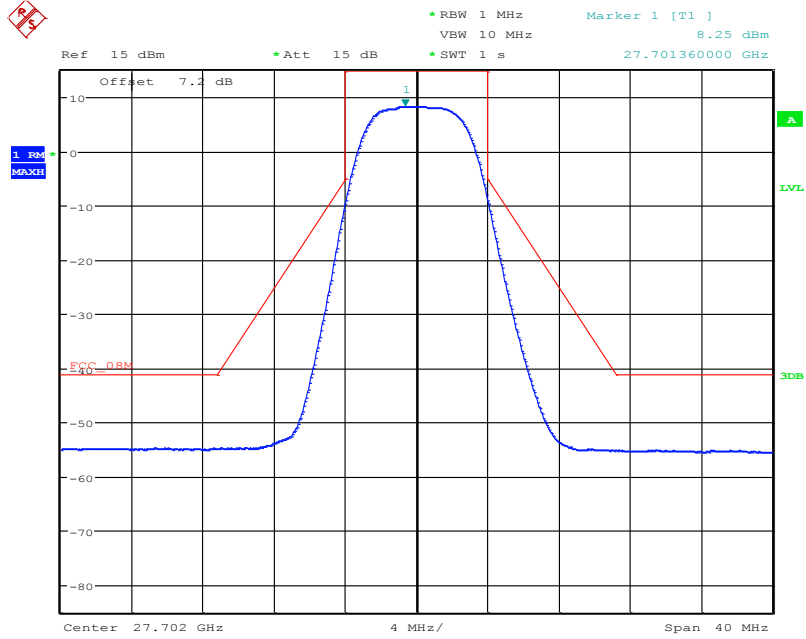

Date: 26.SEP.2016 16:59:45

Plot No. A.17: 256QAM

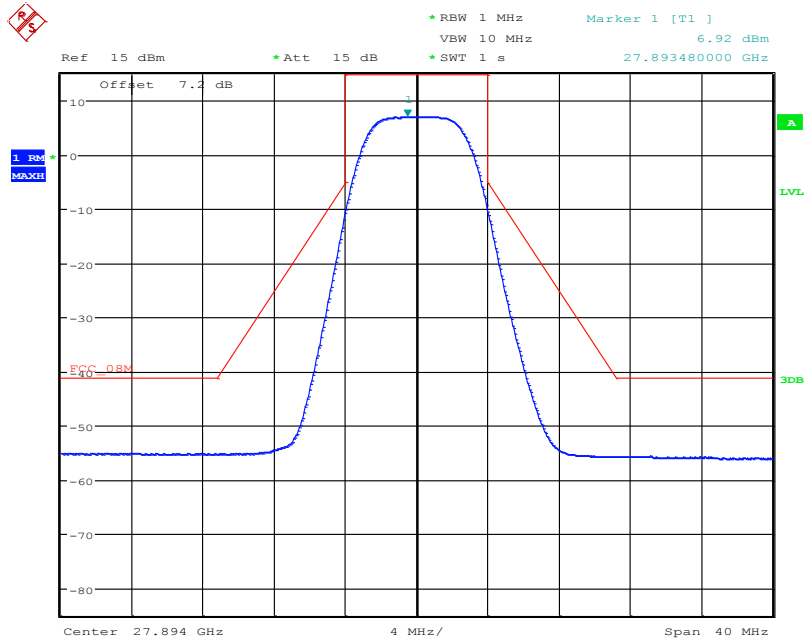

Date: 26.SEP.2016 17:00:20

Plot No. A.18: 256QAM

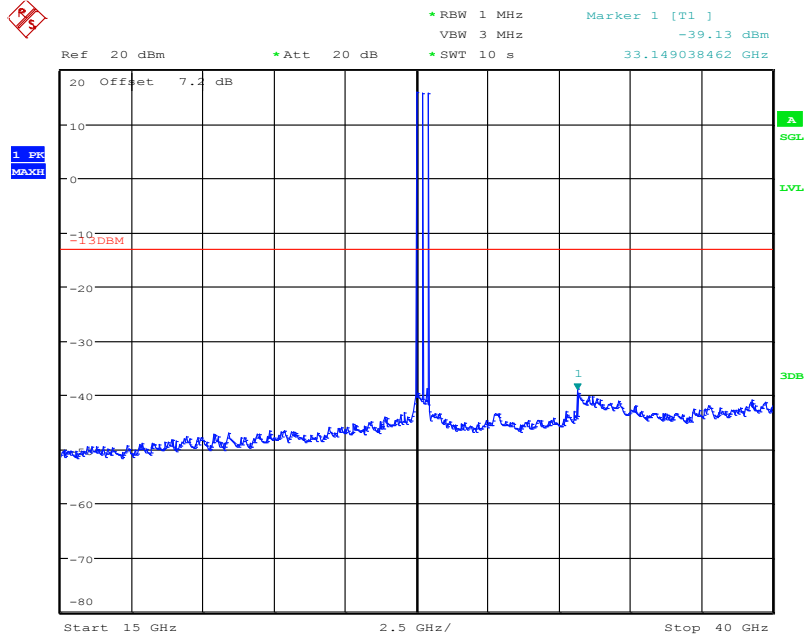

Date: 26.SEP.2016 17:16:48

**Note:** Plot shows wanted signals (low/mid/high).

Plot No. A.19: 256QAM

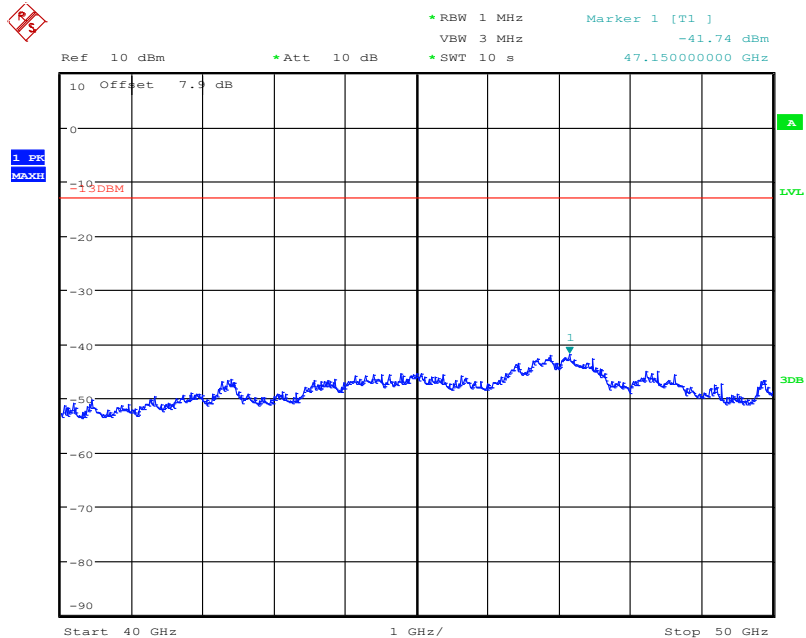

Date: 27.SEP.2016 08:30:18



Plot No. A.20: 256QAM

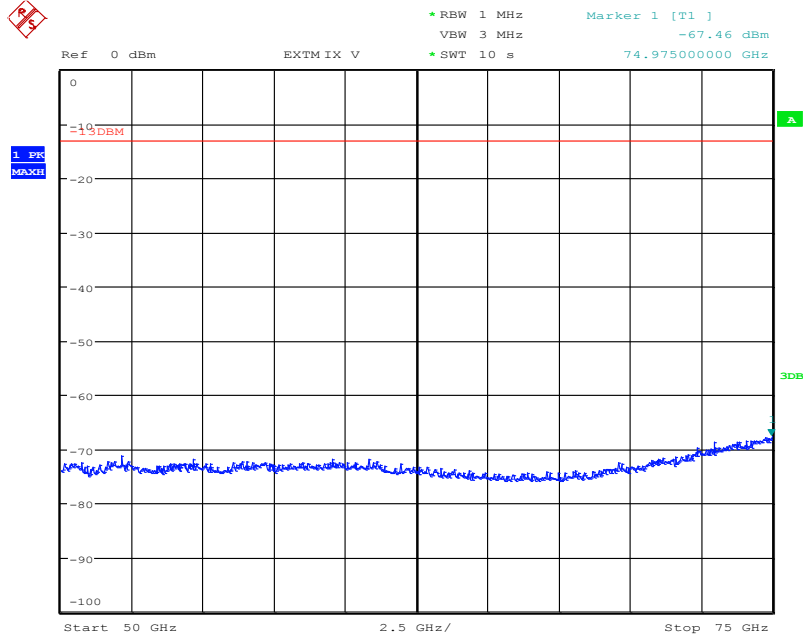

Date: 27.SEP.2016 10:00:52

Plot No. A.21: 256QAM

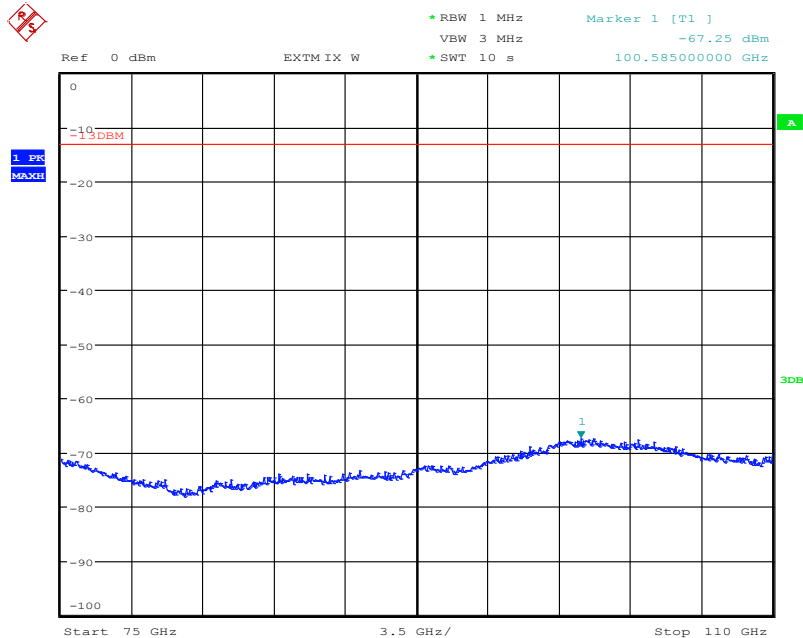

Date: 27.SEP.2016 10:25:21

Plot No. A.22: 256QAM

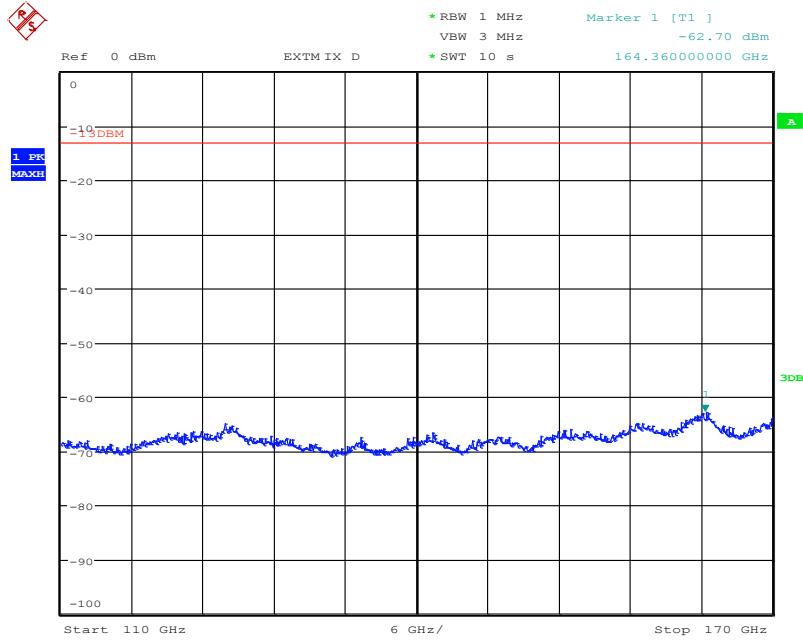

Date: 27.SEP.2016 10:44:45

Plot No. A.23: low/mid/high

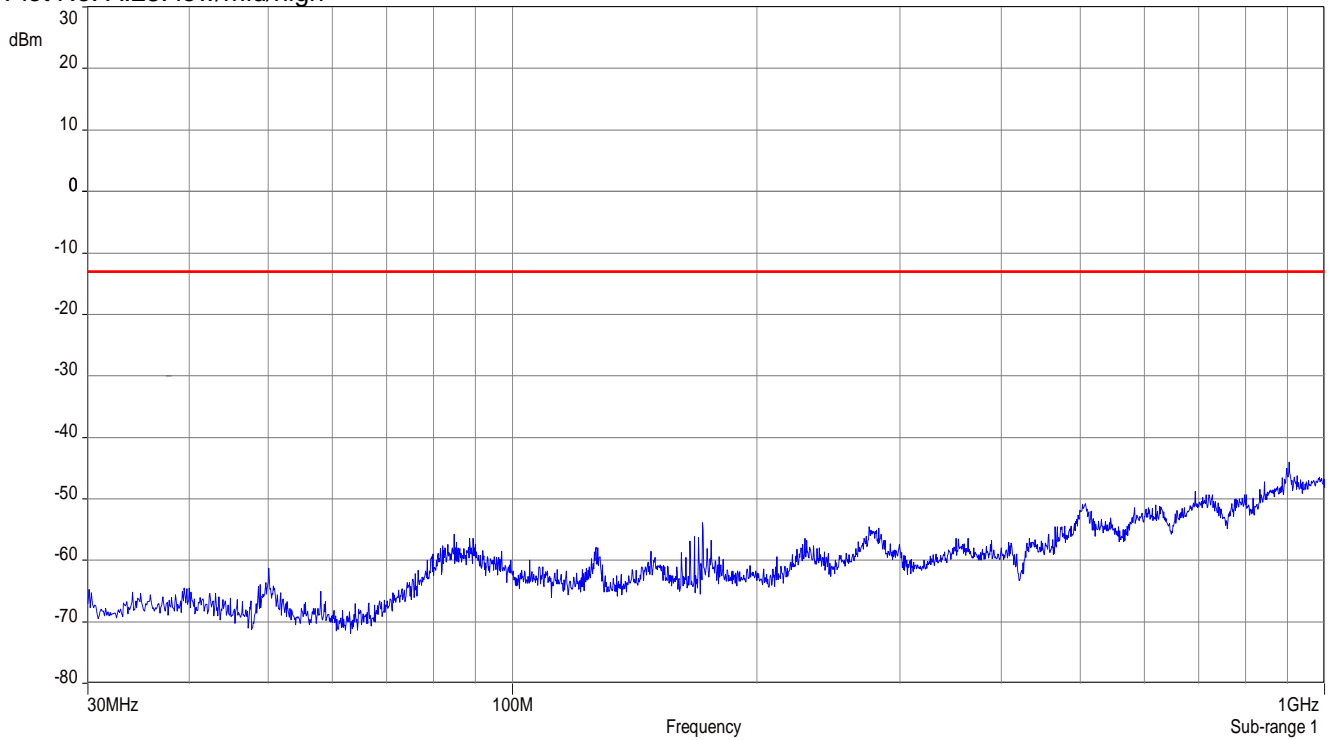

Plot No. A.24: low/mid/high

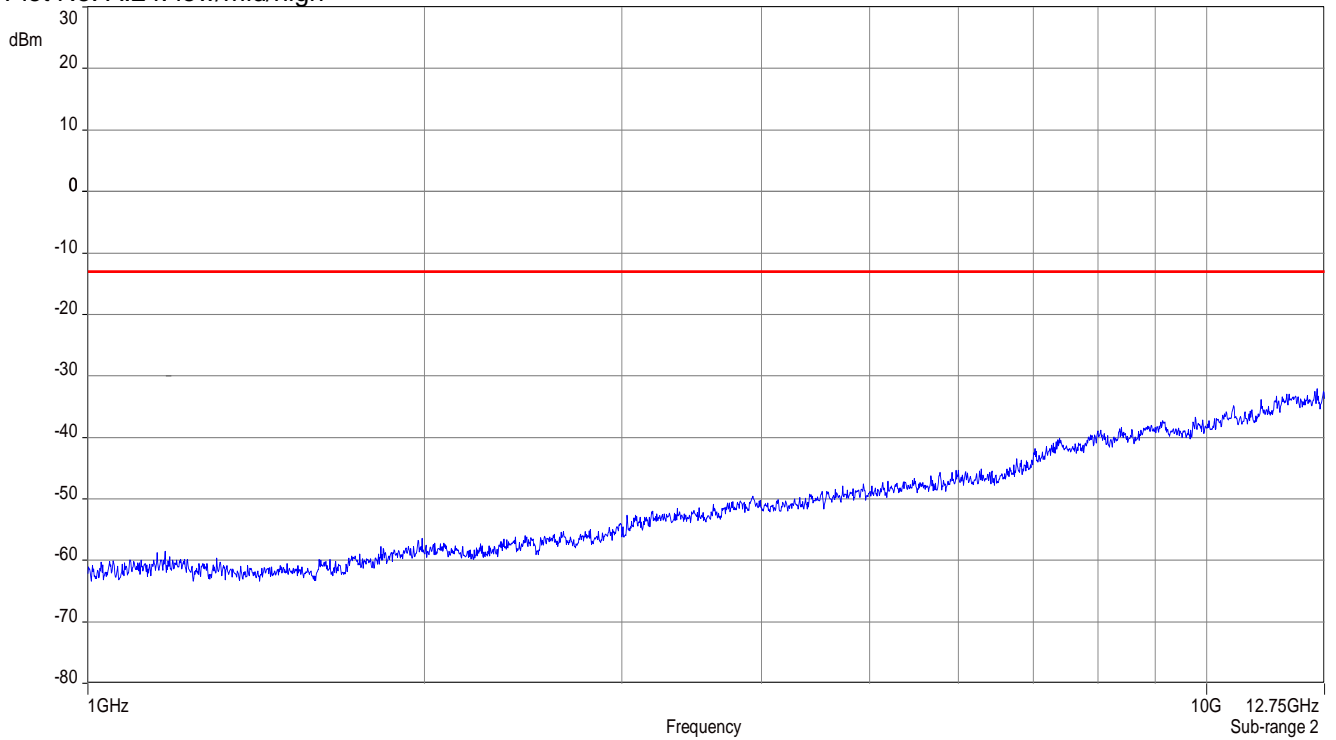

Plot No. A.25: low/mid/high

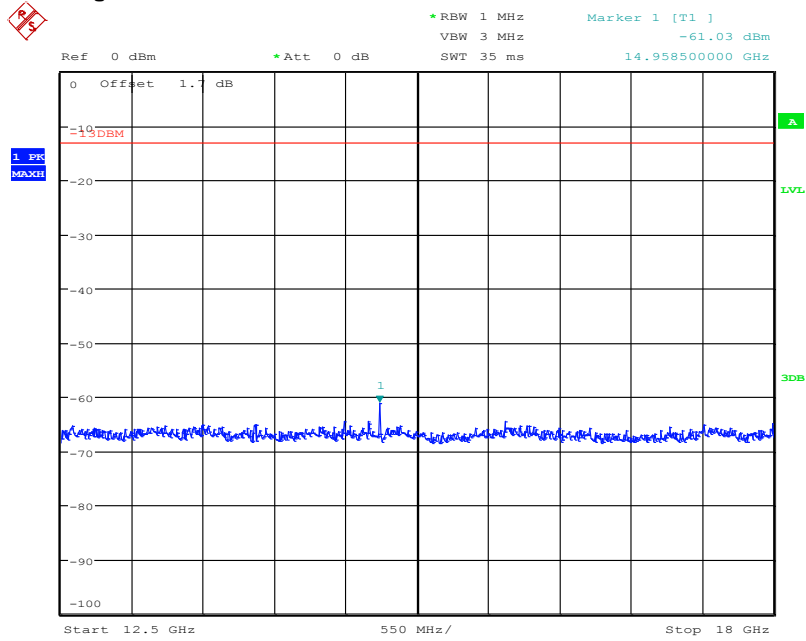

Date: 30.SEP.2016 11:29:55

Plot No. A.26: low/mid/high

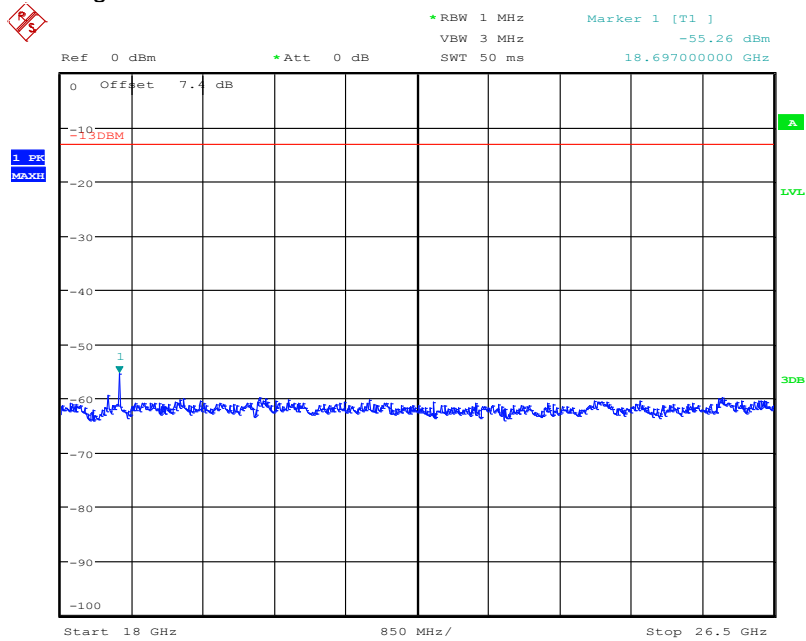

Date: 30.SEP.2016 13:06:51

Plot No. A.27: low/mid/high

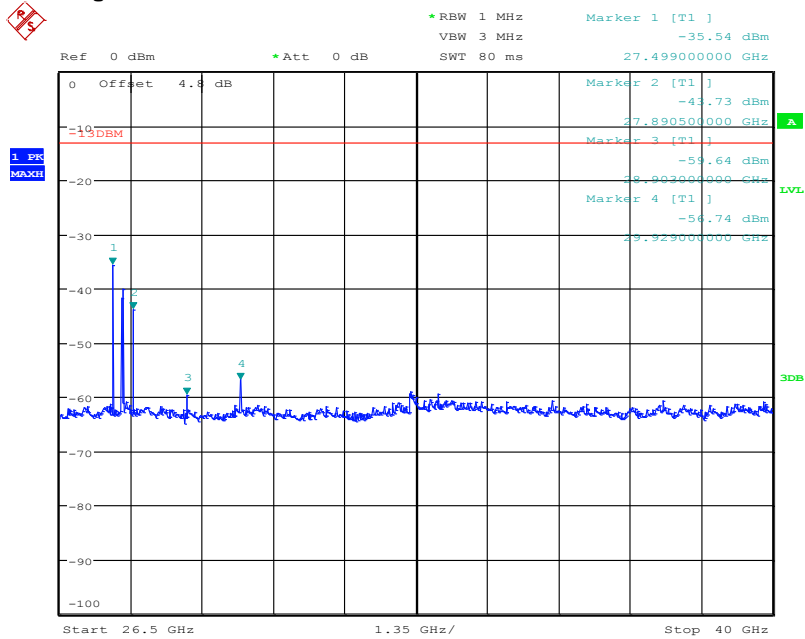

Date: 30.SEP.2016 13:19:18

**Note:** Plot shows wanted signals (low/mid/high).

Plot No. A.28: low/mid/high

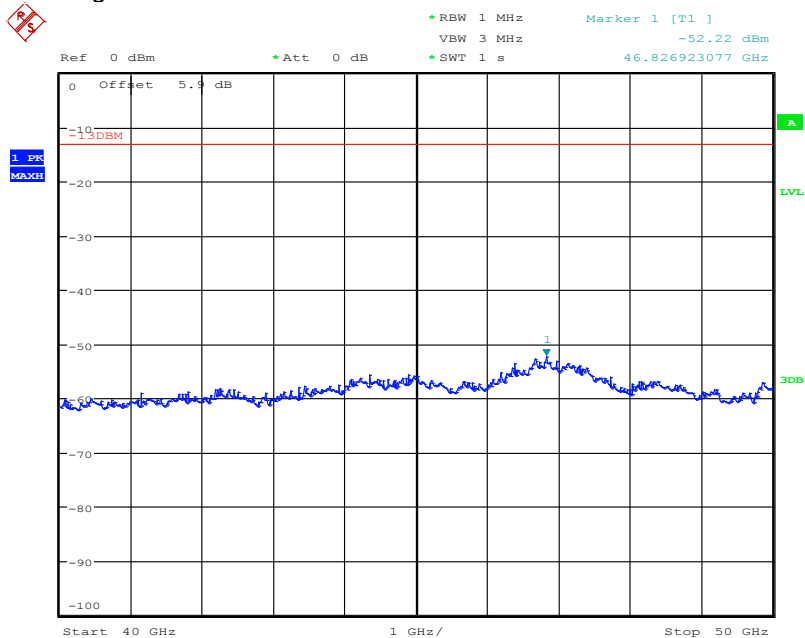

Date: 4.OCT.2016 13:40:19

Plot No. A.29: low/mid/high

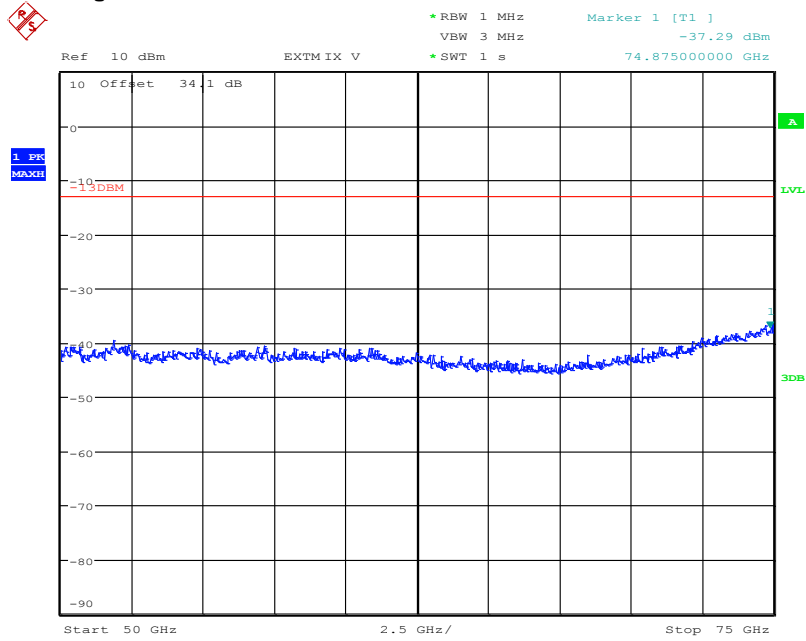

Date: 4.OCT.2016 14:01:18

Plot No. A.30: low/mid/high

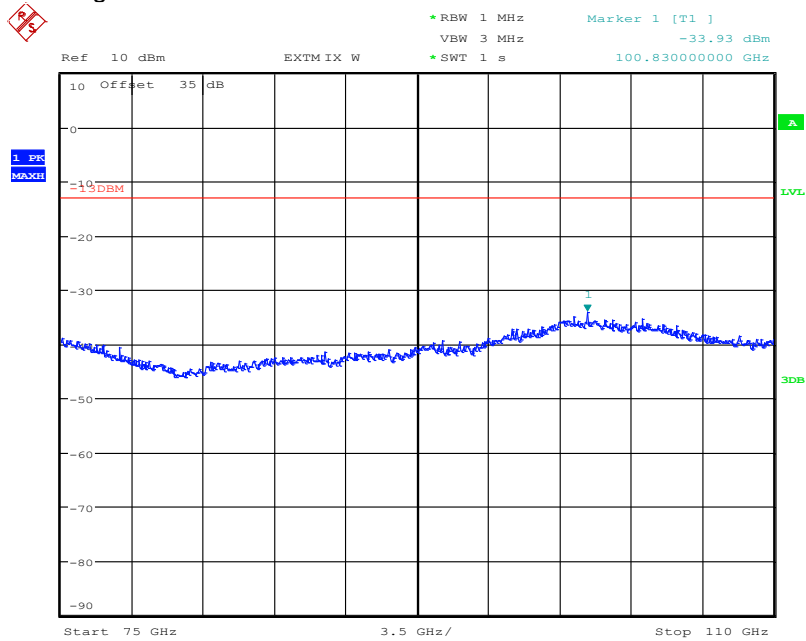

Date: 4.OCT.2016 14:47:03

Plot No. A.31: low/mid/high

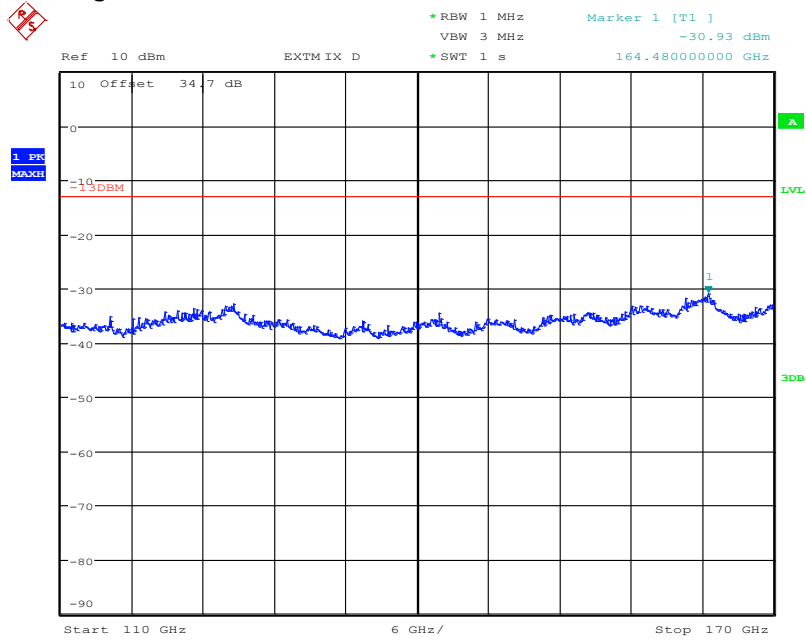

Date: 4.OCT.2016 14:41:32

## 8.4 Plots (Band 2)

Plot No. B.1: 64QAM

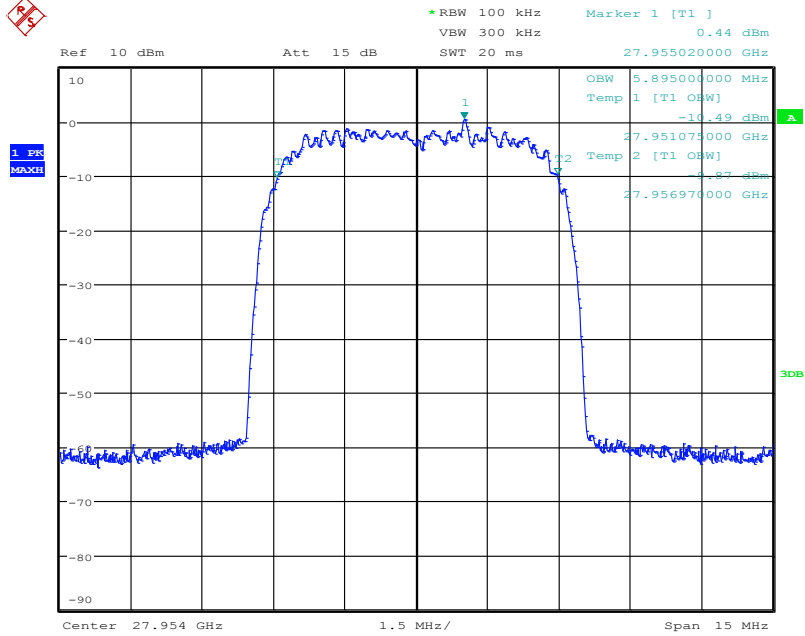

Date: 27.SEP.2016 13:38:30

Plot No. B.2: 64QAM

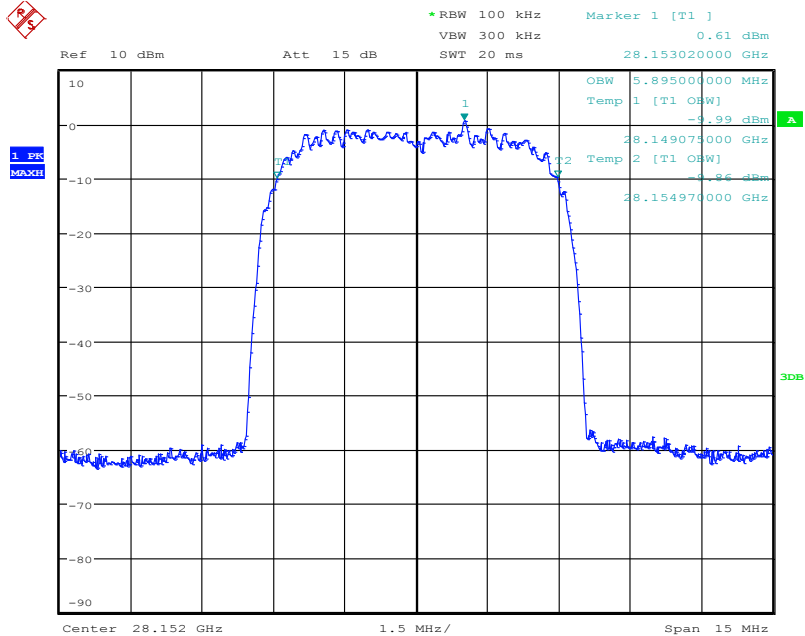

Date: 27.SEP.2016 13:37:53



Plot No. B.3: 64QAM

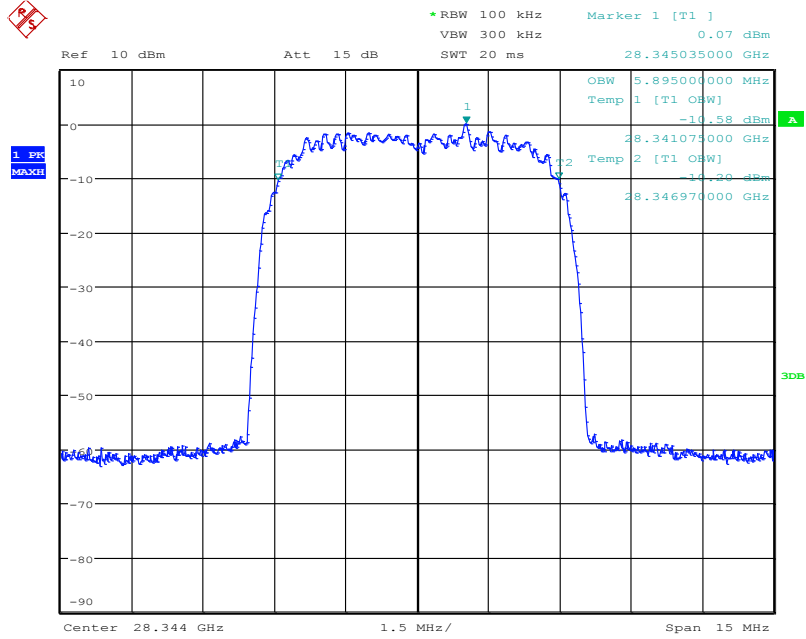

Date: 27.SEP.2016 13:35:28

Plot No. B.4: 64QAM

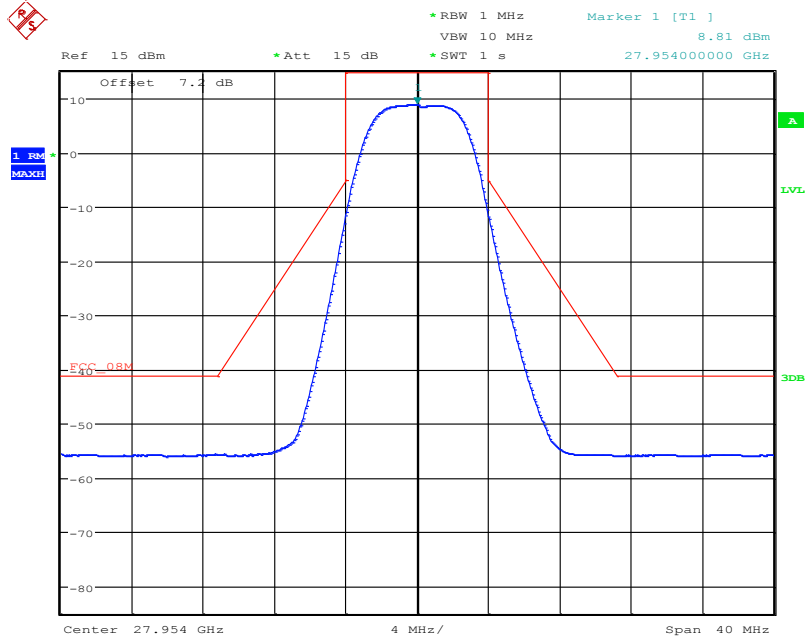

Date: 27.SEP.2016 13:43:47

Plot No. B.5: 64QAM

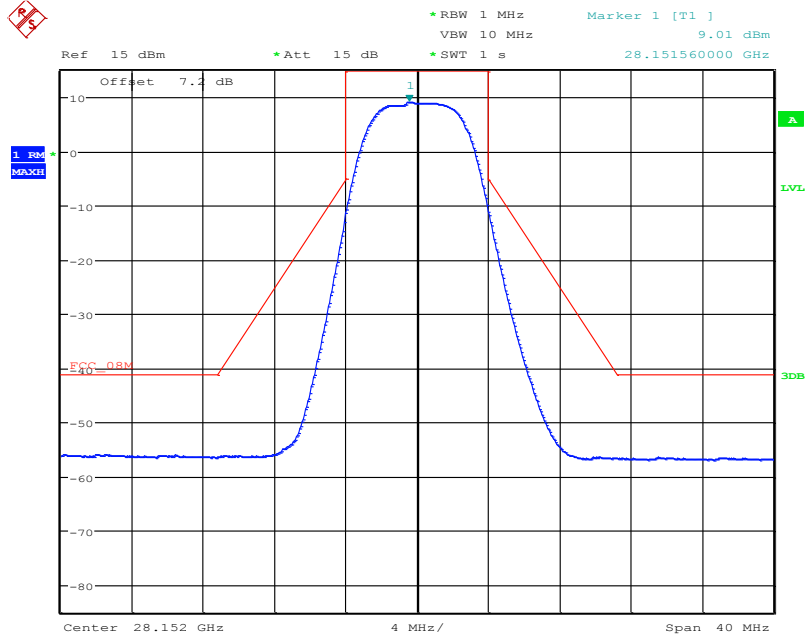

Date: 27.SEP.2016 13:45:34

Plot No. B.6: 64QAM

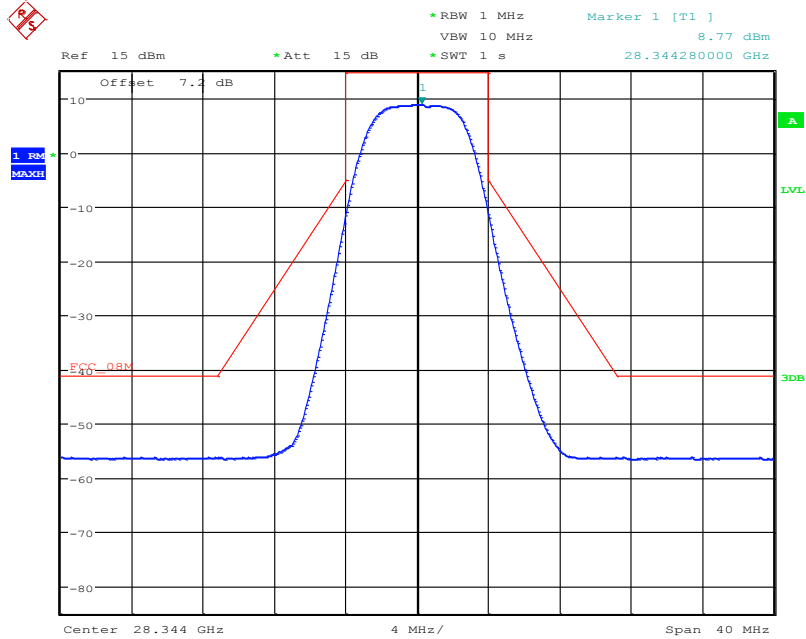

Date: 27.SEP.2016 13:46:17

Plot No. B.7: 64QAM

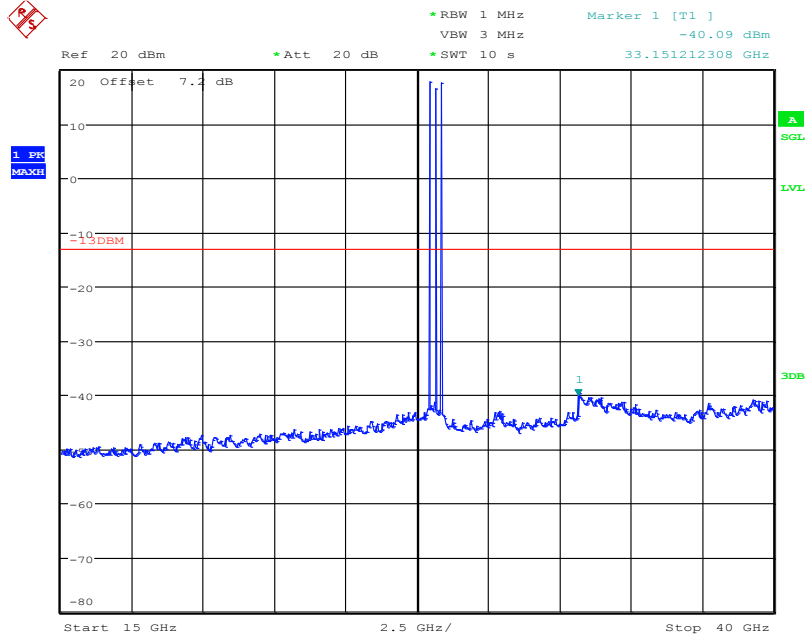

Date: 27.SEP.2016 15:07:35

**Note:** Plot shows wanted signals (low/mid/high).

Plot No. B.8: 64QAM

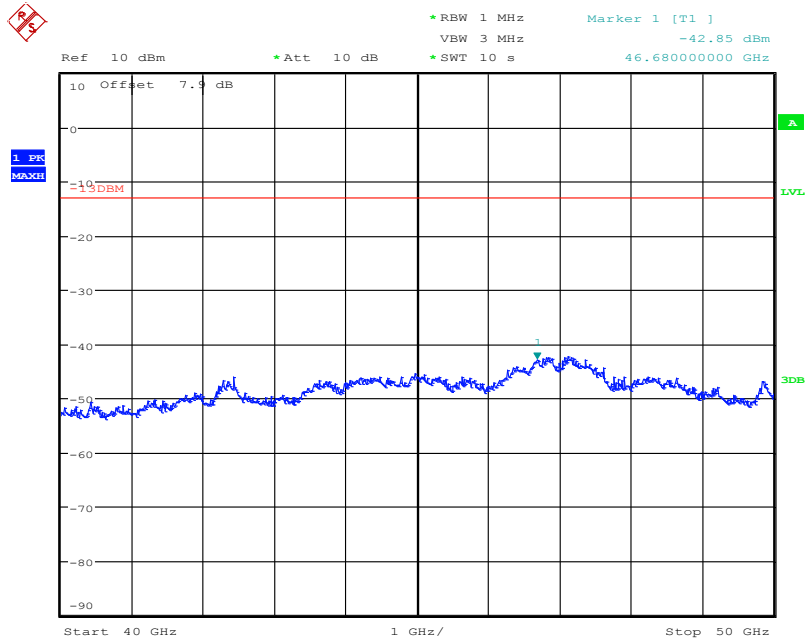

Date: 27.SEP.2016 15:36:54

Plot No. B.9: 64QAM

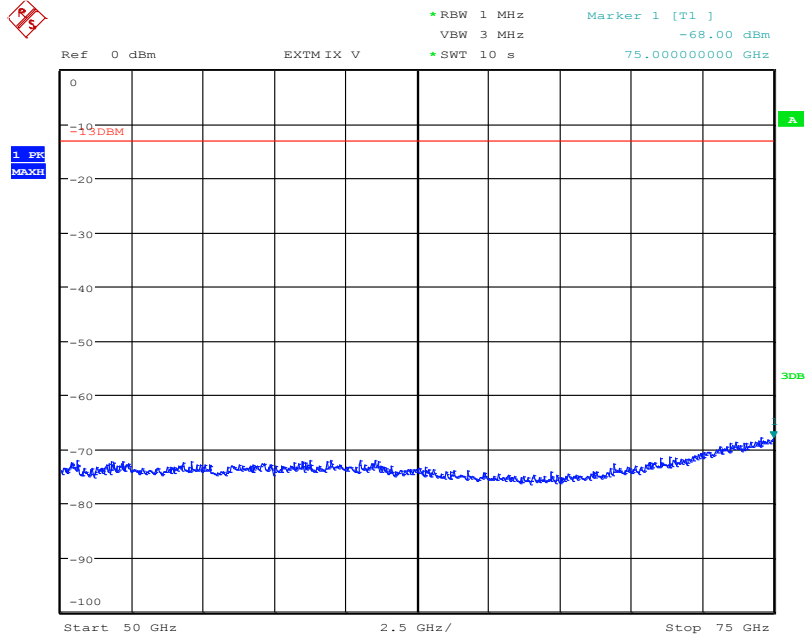

Date: 27.SEP.2016 16:01:37

Plot No. B.10: 64QAM

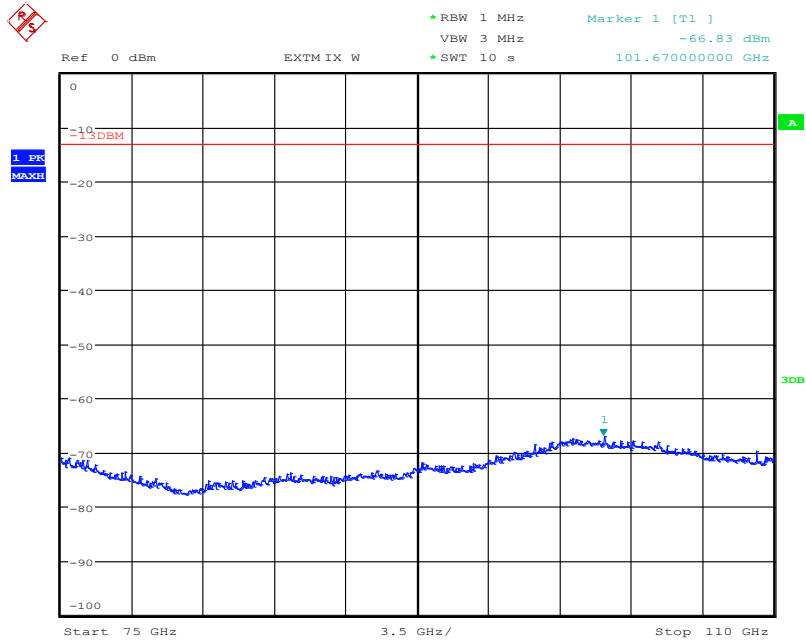

Date: 27.SEP.2016 16:14:54

Plot No. B.11: 64QAM

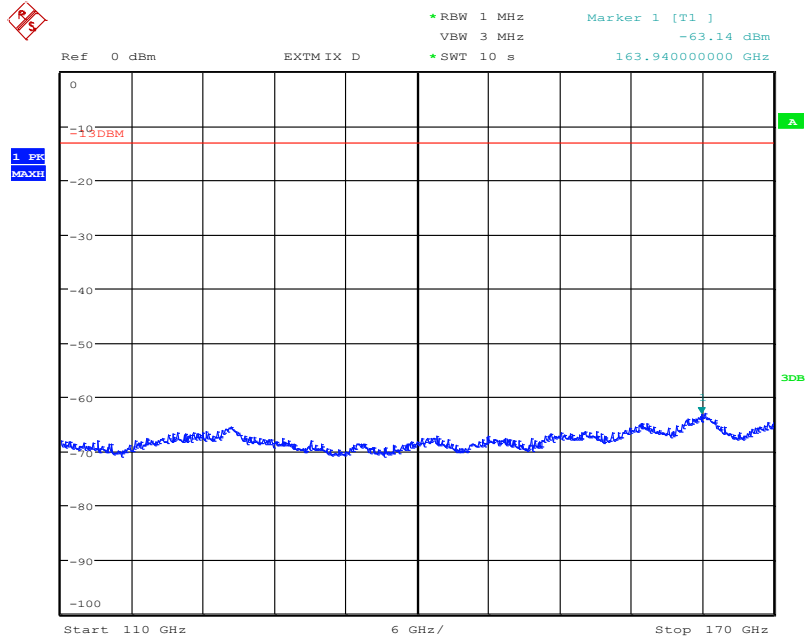

Date: 27.SEP.2016 16:47:23

Plot No. B.12: 256QAM

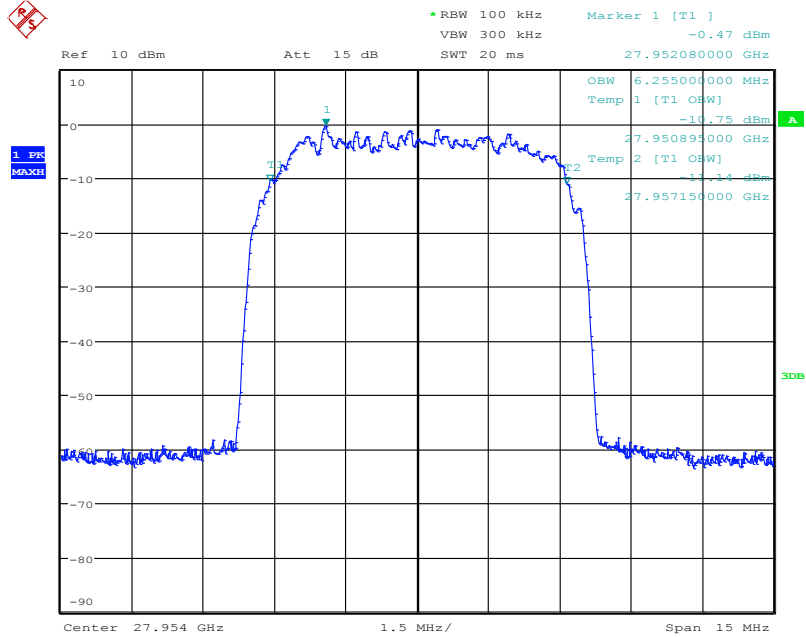

Date: 27.SEP.2016 13:39:00

Plot No. B.13: 256QAM

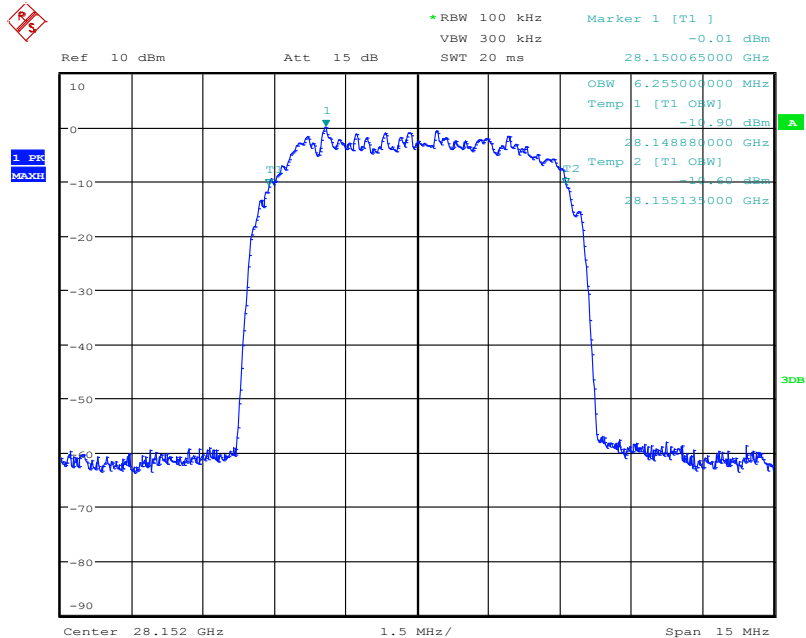

Date: 27.SEP.2016 13:37:15

Plot No. B.14: 256QAM

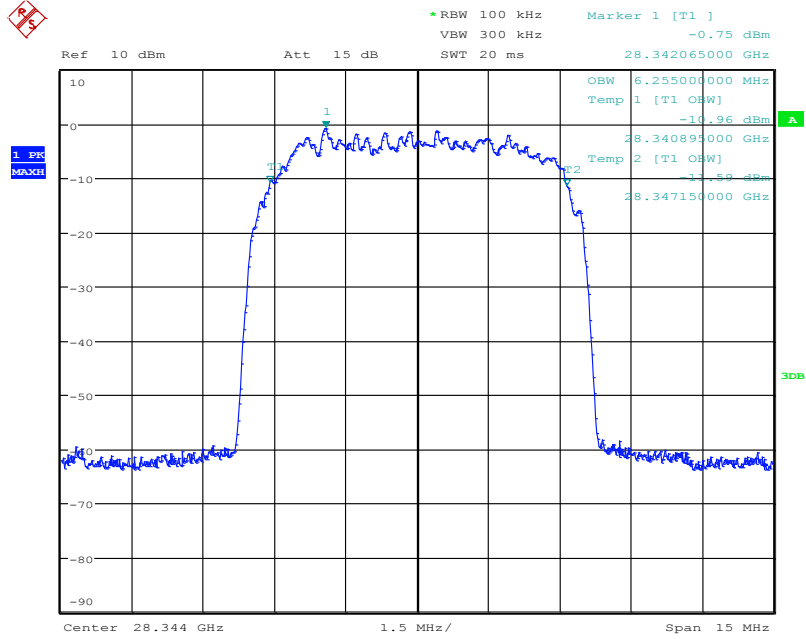

Date: 27.SEP.2016 13:36:37

Plot No. B.15: 256QAM

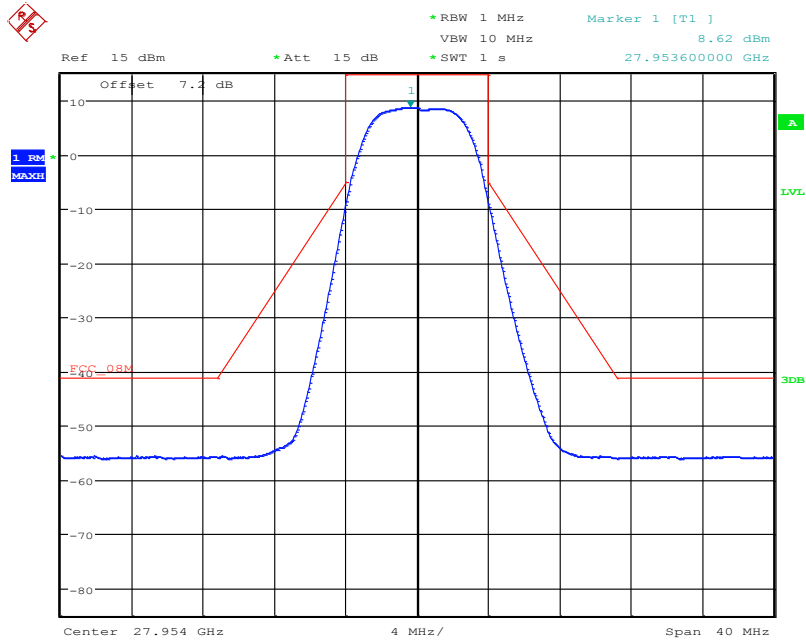

Date: 27.SEP.2016 13:44:13

Plot No. B.16: 256QAM

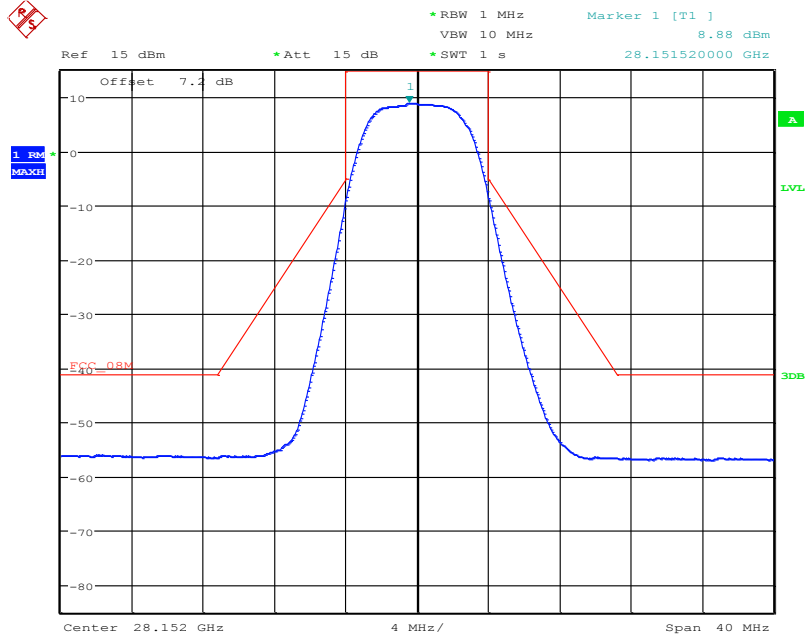

Date: 27.SEP.2016 13:44:53

Plot No. B.17: 256QAM

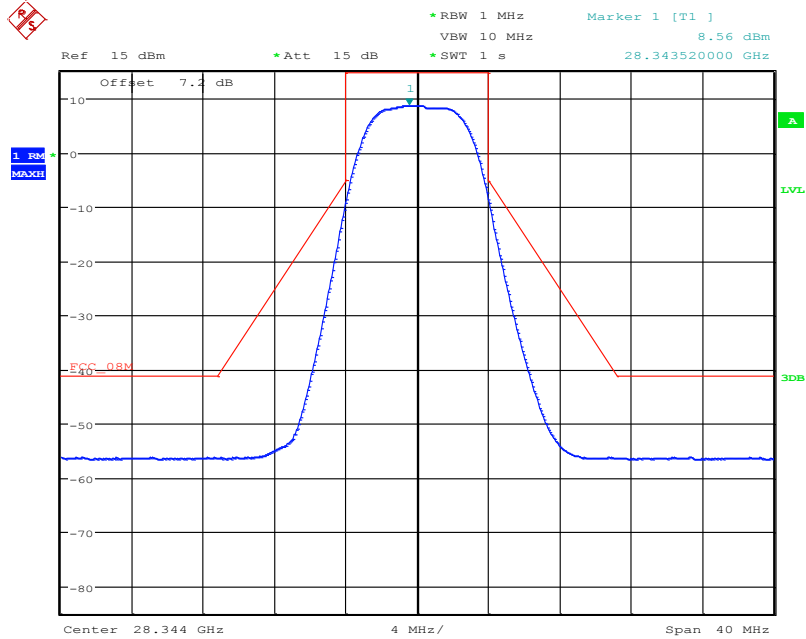

Date: 27.SEP.2016 13:46:50



Plot No. B.18: 256QAM

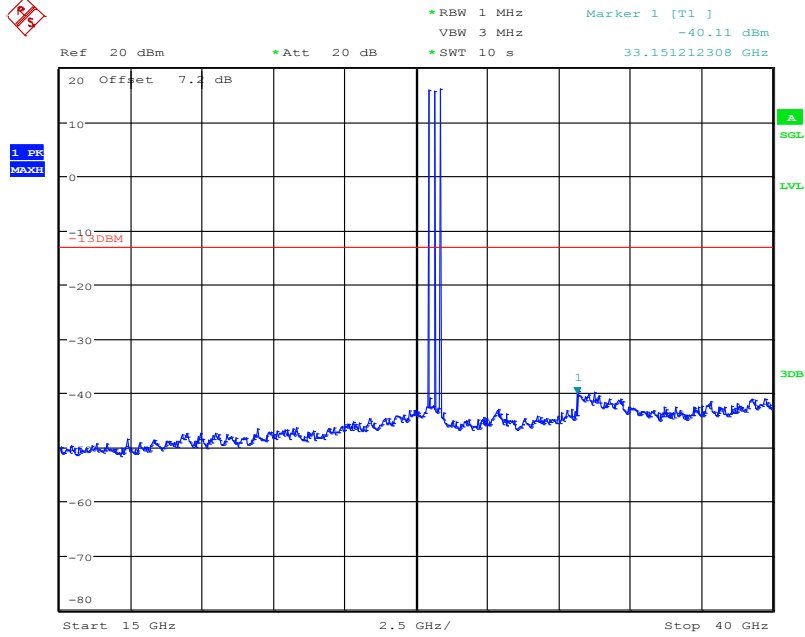

Date: 27.SEP.2016 13:55:41

**Note:** Plot shows wanted signals (low/mid/high).

Plot No. B.19: 256QAM

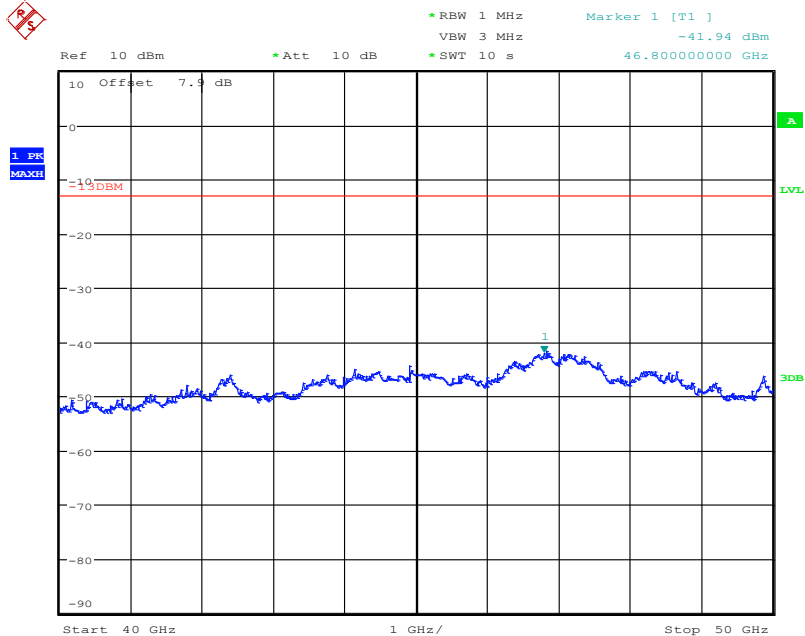

Date: 27.SEP.2016 15:42:53

Plot No. B.20: 256QAM

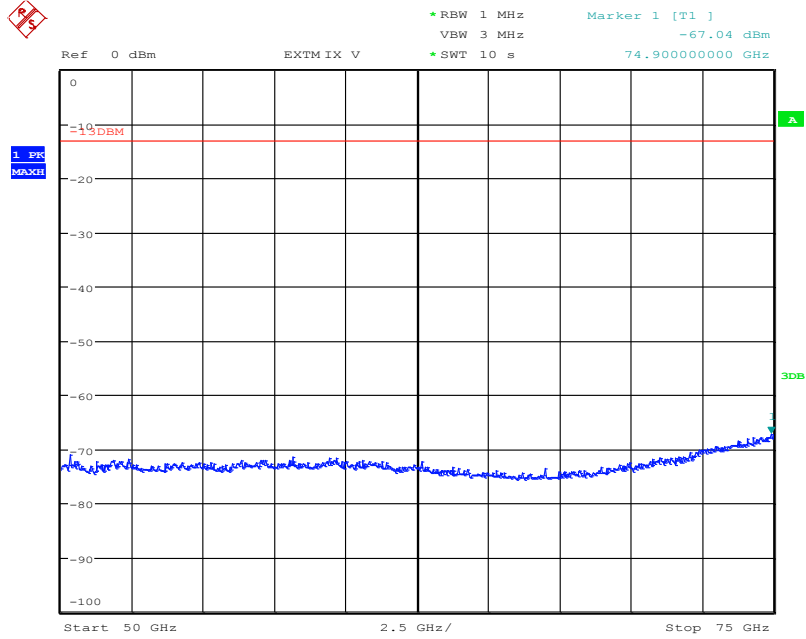

Date: 27.SEP.2016 15:59:55

Plot No. B.21: 256QAM

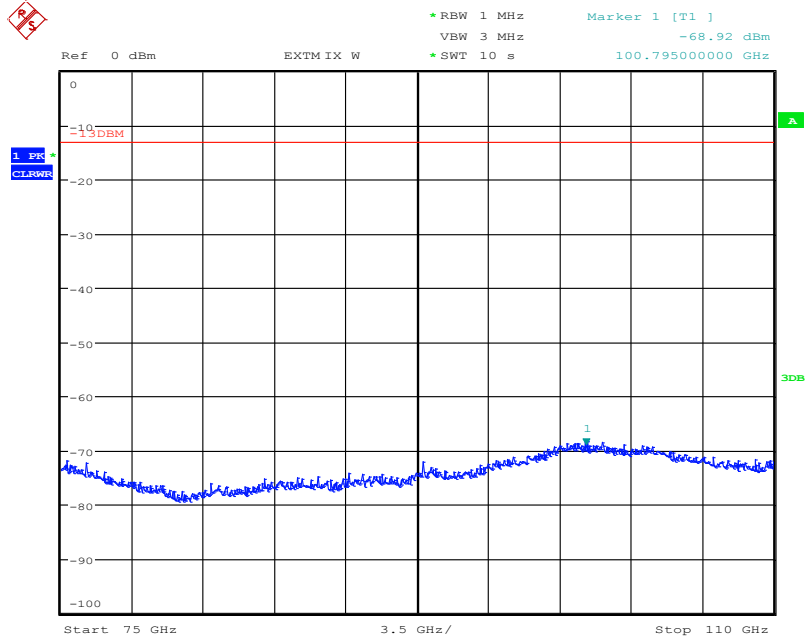

Date: 27.SEP.2016 16:24:50

Plot No. B.22: 256QAM

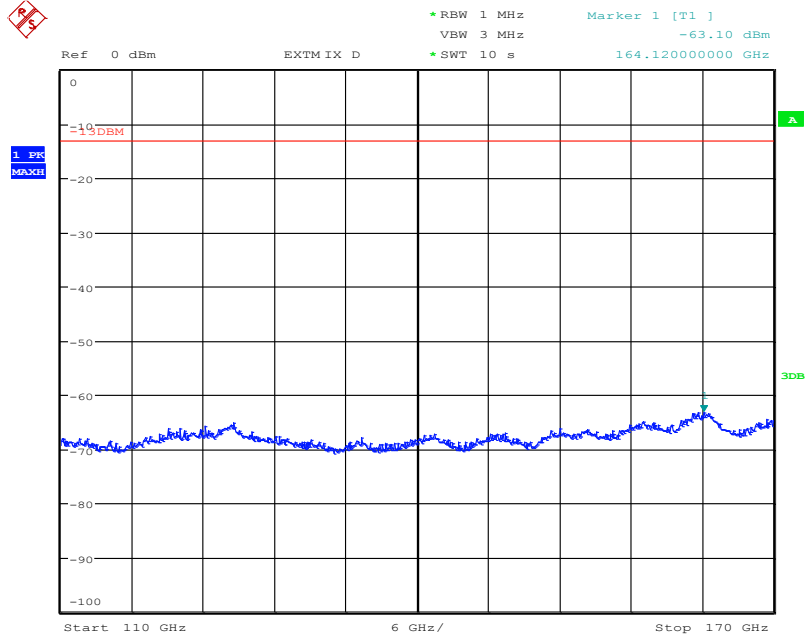

Date: 27.SEP.2016 16:44:51

Plot No. B.23: low/mid/high

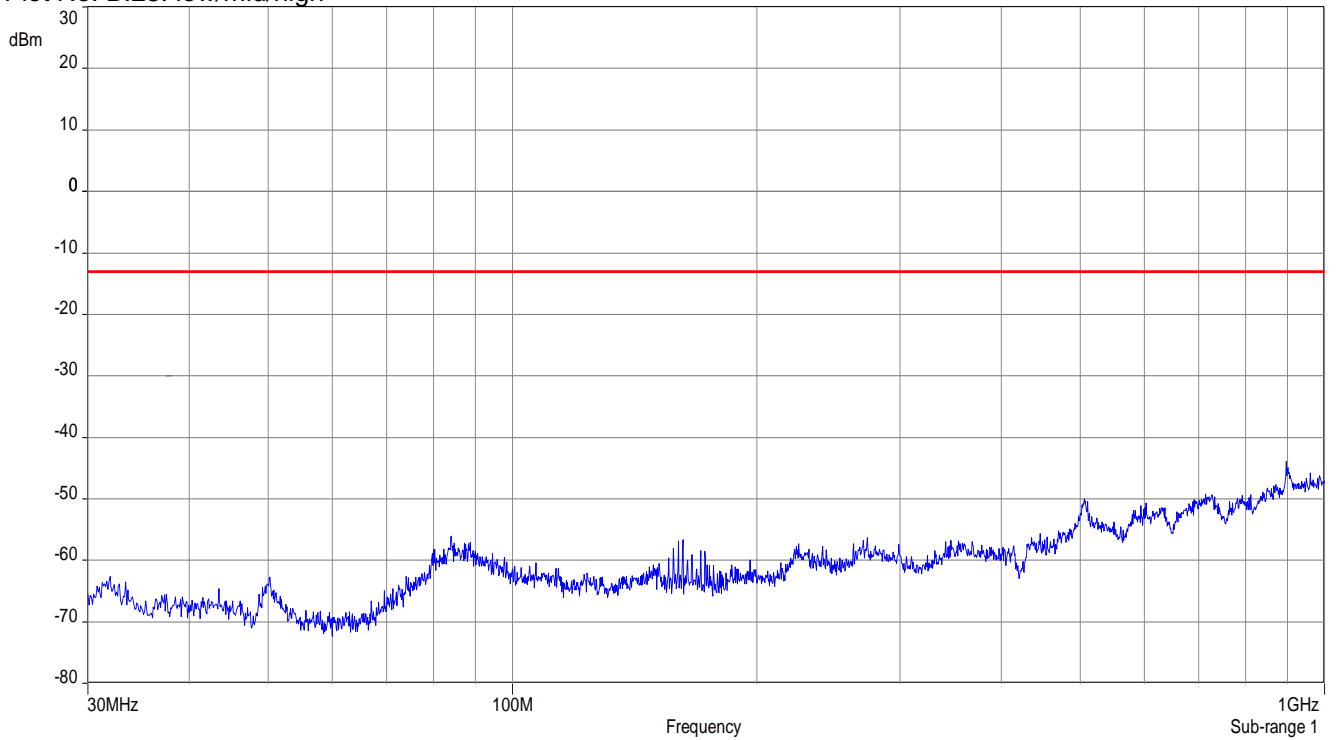

Plot No. B.24: low/mid/high

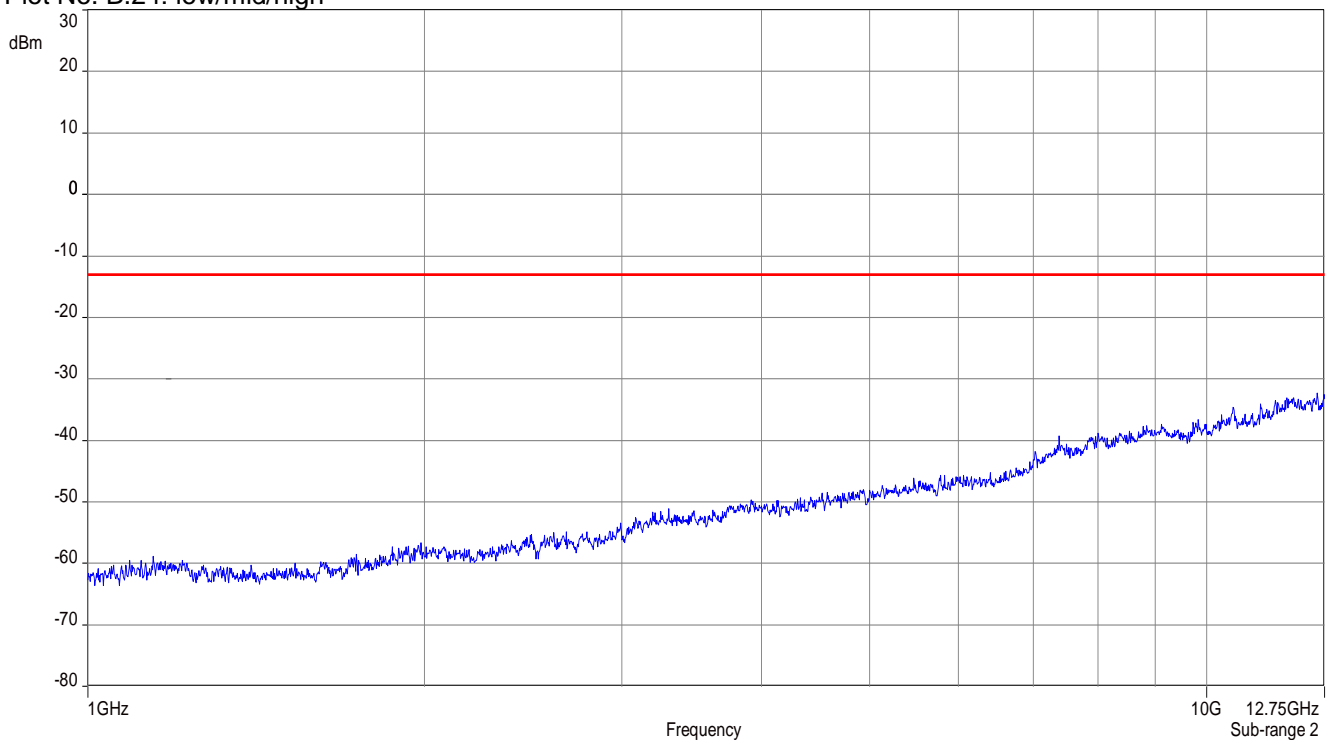

Plot No. B.25: low/mid/high

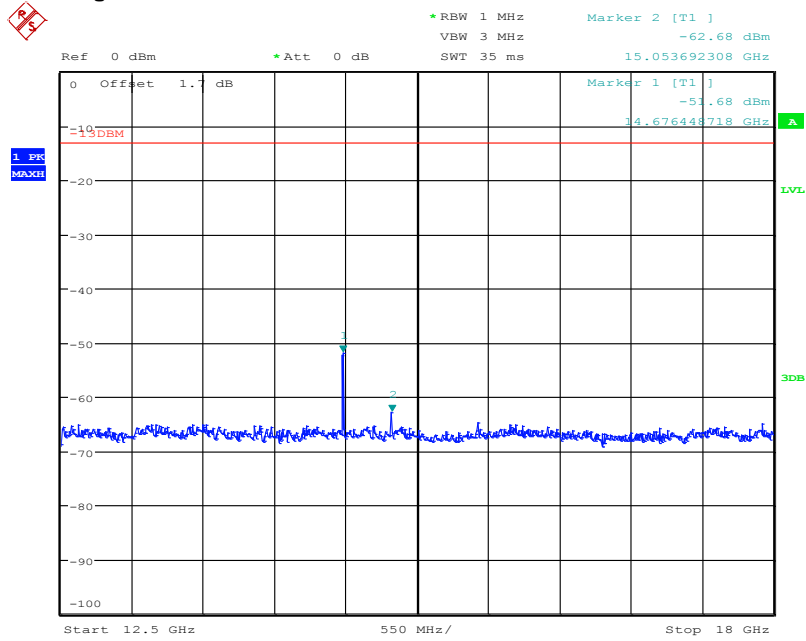

Date: 30.SEP.2016 11:37:08

Plot No. B.26: low/mid/high

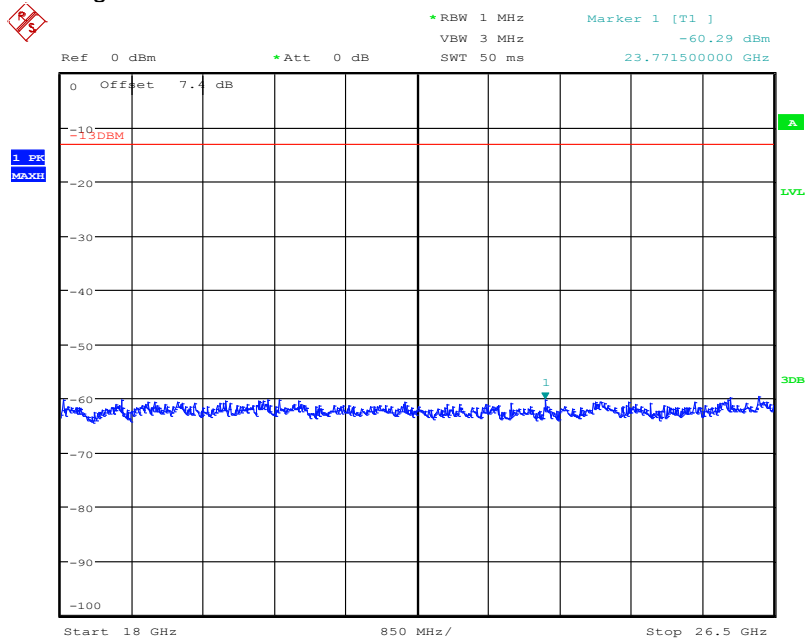

Date: 30.SEP.2016 13:03:35

Plot No. B.27: low/mid/high

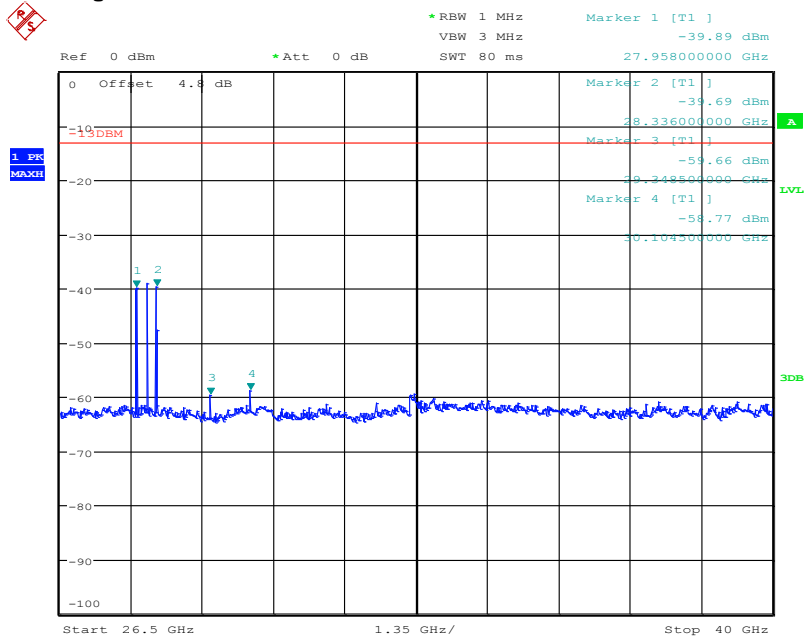

Date: 30.SEP.2016 13:26:23

Plot No. B.28: low/mid/high

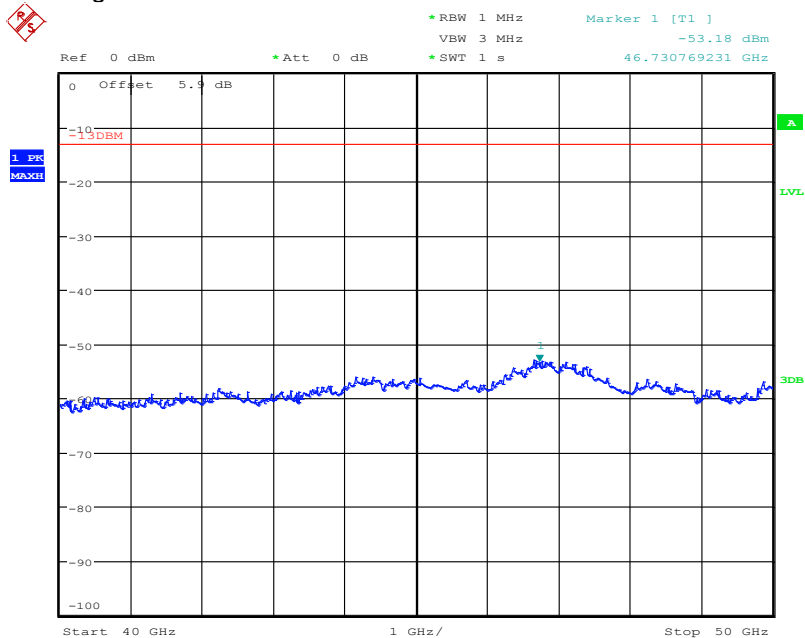

Date: 4.OCT.2016 13:20:13

Plot No. B.29: low/mid/high

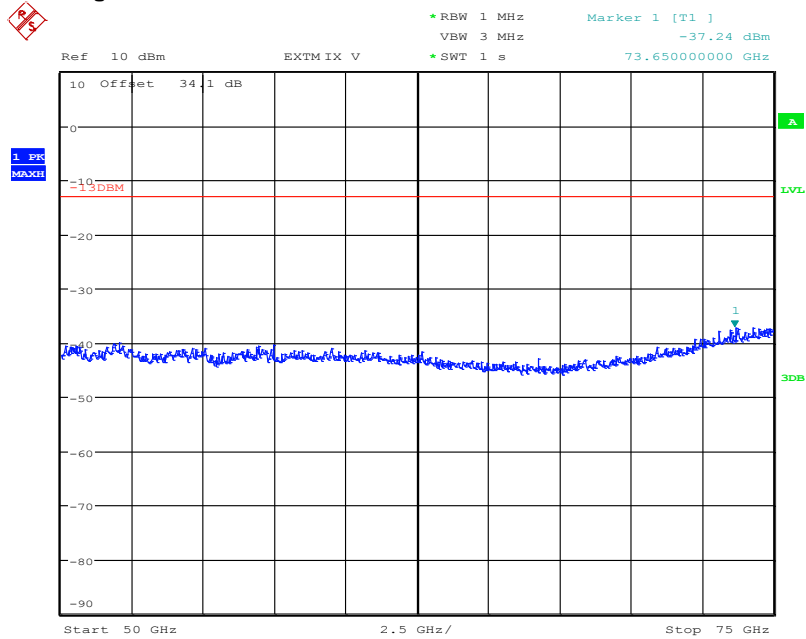

Date: 4.OCT.2016 14:03:01

Plot No. B.30: low/mid/high

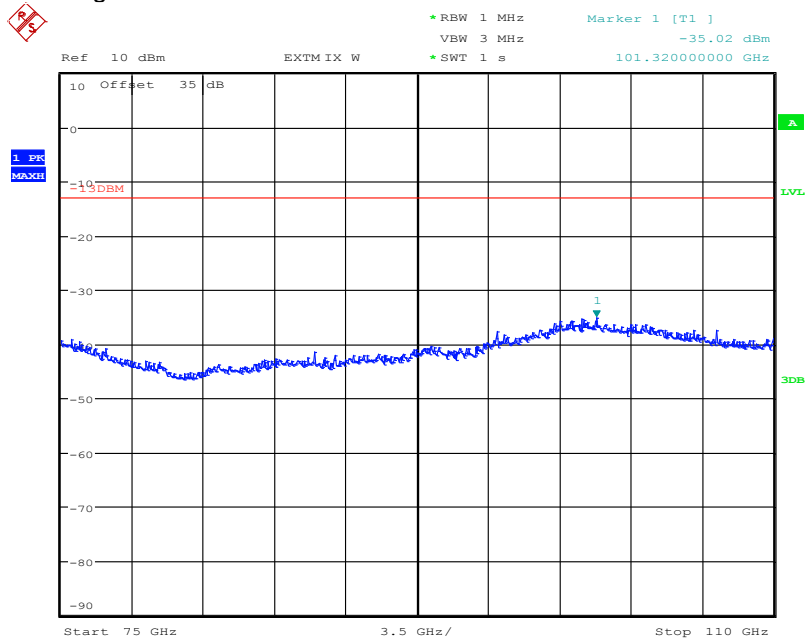

Date: 4.OCT.2016 14:47:23

Plot No. B.31: low/mid/high

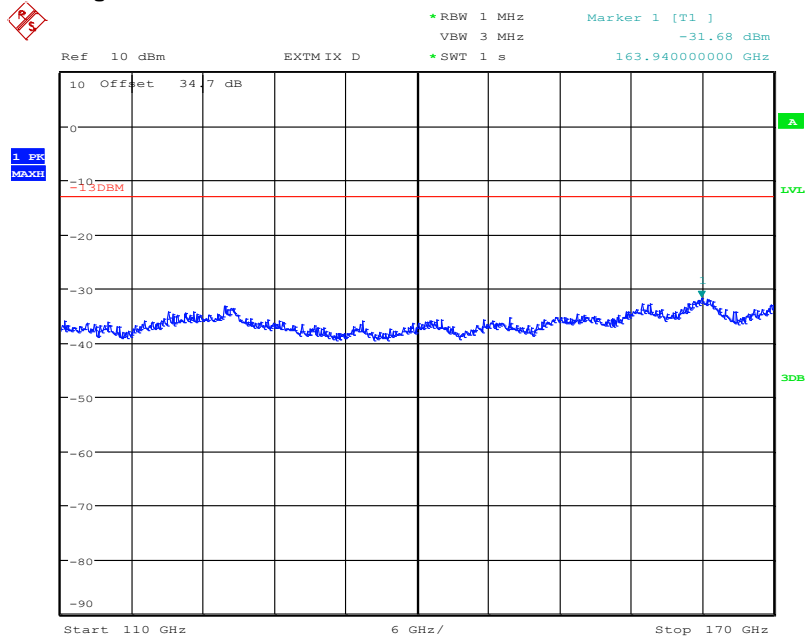

Date: 4.OCT.2016 14:44:13



## Annex A Document history

Version	Applied changes	Date of release
	Initial release - DRAFT	2016-11-25
	editorial changes based on applicant's remarks	2016-12-13

## Annex B Further information

### Glossary

AVG	-	Average
DUT	-	Device under test
EMC	-	Electromagnetic Compatibility
EN	-	European Standard
EUT	-	Equipment under test
ETSI	-	European Telecommunications Standard Institute
FCC	-	Federal Communication Commission
FCC ID	-	Company Identifier at FCC
HW	-	Hardware
IC	-	Industry Canada
Inv. No.	-	Inventory number
N/A	-	Not applicable
PP	-	Positive peak
QP	-	Quasi peak
S/N	-	Serial number
SW	-	Software
PMN	-	Product marketing name
HMN	-	Host marketing name
HVIN	-	Hardware version identification number
FVIN	-	Firmware version identification number
OBW		Occupied Bandwidth
OC		Operating Channel
OCW		Operating Channel Bandwidth
OOB		Out Of Band

**Annex C Accreditation Certificate**

Front side of certificate

Back side of certificate



Deutsche Akkreditierungsstelle GmbH

Befehlens gemäß § 8 Absatz 1 AkkStelleG i.V.m. § 1 Absatz 1 AkkStelleGBV  
 Unterzeichnerin der Multilateralen Abkommen  
 von EA, ILAC und IAF zur gegenseitigen Anerkennung

**Akkreditierung**



Die Deutsche Akkreditierungsstelle GmbH bestätigt hiermit, dass das Prüflaboratorium

**CTC advanced GmbH**  
 Untertürkheimer Straße 6-10, 66117 Saarbrücken

die Kompetenz nach DIN EN ISO/IEC 17025:2005 besitzt, Prüfungen in folgenden Bereichen durchzuführen:

- Funk**
- Mobilfunk (GSM / DCS) + OTA
- Elektromagnetische Verträglichkeit (EMV)
- Produktsicherheit
- SAR / EMF
- Umwelt
- Smart Card Technology
- Bluetooth\*
- Automotive
- Wi-Fi-Services
- Kanadische Anforderungen
- US-Anforderungen
- Akustik
- Near Field Communication (NFC)

Die Akkreditierungsurkunde gilt nur in Verbindung mit dem Bescheid vom 25.11.2016 mit der Akkreditierungsnummer D-PL-12076-01 und ist gültig bis 17.01.2018. Sie besteht aus diesem Deckblatt, der Rückseite des Deckblatts und der folgenden Anlage mit insgesamt 63 Seiten.

Registrierungsnummer der Urkunde: D-PL-12076-01-01

Frankfurt, 25.11.2016

Siehe Hinweis auf der Rückseite

Im Auftrag Dipl.-Ing. Ralf Eigner  
 Abteilungsleiter

Deutsche Akkreditierungsstelle GmbH

Standort Berlin  
 Spittelmarkt 10  
 10117 Berlin

Standort Frankfurt am Main  
 Europa-Allee 52  
 60327 Frankfurt am Main

Standort Braunschweig  
 Bundesallee 100  
 38116 Braunschweig

Die auszugsweise Veröffentlichung der Akkreditierungsurkunde bedarf der vorherigen schriftlichen Zustimmung der Deutsche Akkreditierungsstelle GmbH (DAkkS). Ausgenommen davon ist die separate Weiterverbreitung des Deckblattes durch die umseitig genannte Konformitätsbewertungsstelle in unveränderter Form.

Es darf nicht der Anschein erweckt werden, dass sich die Akkreditierung auch auf Bereiche erstreckt, die über den durch die DAkkS bestätigten Akkreditierungsbereich hinausgehen.

Die Akkreditierung erfolgte gemäß des Gesetzes über die Akkreditierungsstelle (AkkStelleG) vom 31. Juli 2009 (BGBl. I S. 2625) sowie der Verordnung (EG) Nr. 765/2008 des Europäischen Parlaments und des Rates vom 9. Juli 2008 über die Vorschriften für die Akkreditierung und Marktüberwachung im Zusammenhang mit der Vermarktung von Produkten (Abl. L 218 vom 9. Juli 2008, S. 30). Die DAkkS ist Unterzeichnerin der Multilateralen Abkommen zur gegenseitigen Anerkennung der European co-operation for Accreditation (EA), des International Accreditation Forum (IAF) und der International Laboratory Accreditation Cooperation (ILAC). Die Unterzeichner dieser Abkommen erkennen ihre Akkreditierungen gegenseitig an.

Der aktuelle Stand der Mitgliedschaft kann folgenden Webseiten entnommen werden:  
 EA: [www.european-accrreditation.org](http://www.european-accrreditation.org)  
 ILAC: [www.ilac.org](http://www.ilac.org)  
 IAF: [www.iaf.nu](http://www.iaf.nu)

**Note:**  
 The current certificate including annex can be received from CTC advanced GmbH on request.