



FCC RF Test Report

APPLICANT : Gillon UK LLC
EQUIPMENT : HDMI Digital Media Receiver
MODEL NAME : LDC9WZ
FCC ID : 2ALBL-1731
STANDARD : FCC Part 15 Subpart C §15.247
CLASSIFICATION : (DTS) Digital Transmission System

The product was completed on Jul. 03, 2017. We, SPORTON INTERNATIONAL INC., would like to declare that the tested sample has been evaluated in accordance with the test procedures and has been in compliance with the applicable technical standards.

The test results in this report apply exclusively to the tested model / sample. Without written approval of SPORTON INTERNATIONAL INC., the test report shall not be reproduced except in full.

Reviewed by: Joseph Lin / Supervisor

Approved by: Jones Tsai / Manager



SPORTON INTERNATIONAL INC.

No. 52, Hwa Ya 1st Rd., Hwa Ya Technology Park, Kwei-Shan District, Tao Yuan City, Taiwan, R.O.C.



TABLE OF CONTENTS

REVISION HISTORY.....3

SUMMARY OF TEST RESULT4

1 GENERAL DESCRIPTION5

 1.1 Applicant5

 1.2 Product Feature of Equipment Under Test.....5

 1.3 Product Specification of Equipment Under Test.....6

 1.4 Modification of EUT6

 1.5 Testing Location7

 1.6 Applicable Standards.....7

2 TEST CONFIGURATION OF EQUIPMENT UNDER TEST8

 2.1 Carrier Frequency and Channel8

 2.2 Test Mode.....9

 2.3 Connection Diagram of Test System.....10

 2.4 Support Unit used in test configuration and system11

 2.5 EUT Operation Test Setup11

 2.6 Measurement Results Explanation Example.....11

3 TEST RESULT12

 3.1 6dB and 99% Bandwidth Measurement12

 3.2 Peak Output Power Measurement14

 3.3 Power Spectral Density Measurement15

 3.4 Conducted Band Edges and Spurious Emission Measurement17

 3.5 Radiated Band Edges and Spurious Emission Measurement68

 3.6 AC Conducted Emission Measurement.....72

 3.7 Antenna Requirements74

4 LIST OF MEASURING EQUIPMENT75

5 UNCERTAINTY OF EVALUATION76

APPENDIX A. CONDUCTED TEST RESULTS

APPENDIX B. AC CONDUCTED EMISSION TEST RESULT

APPENDIX C. RADIATED SPURIOUS EMISSION

APPENDIX D. RADIATED SPURIOUS EMISSION PLOTS

APPENDIX E. DUTY CYCLE PLOTS



REVISION HISTORY

REPORT NO.	VERSION	DESCRIPTION	ISSUED DATE
FR730732-01C	Rev. 01	Initial issue of report	Aug. 21, 2017



SUMMARY OF TEST RESULT

Report Section	FCC Rule	Description	Limit	Result
3.1	15.247(a)(2)	6dB Bandwidth	$\geq 0.5\text{MHz}$	Pass
3.1	-	99% Bandwidth	-	Pass
3.2	15.247(b)	Power Output Measurement	$\leq 30\text{dBm}$	Pass
3.3	15.247(e)	Power Spectral Density	$\leq 8\text{dBm}/3\text{kHz}$	Pass
3.4	15.247(d)	Conducted Band Edges	$\leq 20\text{dBc}$	Pass
		Conducted Spurious Emission		Pass
3.5	15.247(d)	Radiated Band Edges and Radiated Spurious Emission	15.209(a) & 15.247(d)	Pass
3.6	15.207	AC Conducted Emission	15.207(a)	Pass
3.7	15.203 & 15.247(b)	Antenna Requirement	N/A	Pass



1 General Description

1.1 Applicant

Gillon UK LLC

106 E. Sixth Street, Suite 900, Austin, Texas 78701

1.2 Product Feature of Equipment Under Test

Product Feature	
Equipment	HDMI Digital Media Receiver
Model Name	LDC9WZ
FCC ID	2ALBL-1731
EUT supports Radios application	WLAN 11b/g/n HT20 WLAN 11a/n HT20/HT40 WLAN 11ac VHT20/VHT40/VHT80 Bluetooth BR/EDR/LE



1.3 Product Specification of Equipment Under Test

Standards-related Product Specification													
Tx/Rx Channel Frequency Range	2412 MHz ~ 2472 MHz												
Maximum (Peak) Output Power to antenna	<p><Ant. 1> 802.11b : 19.95 dBm (0.0989 W) 802.11g : 22.21 dBm (0.1663 W) 802.11n HT20 : 22.59 dBm (0.1816 W)</p> <p><Ant. 2> 802.11b : 20.54 dBm (0.1132 W) 802.11g : 22.45 dBm (0.1758 W) 802.11n HT20 : 22.85 dBm (0.1928 W)</p> <p>MIMO <Ant. 1 + 2> 802.11g : 25.57 dBm (0.3606 W) 802.11n HT20 : 25.80 dBm (0.3802 W)</p>												
99% Occupied Bandwidth	<p><Ant. 1> 802.11b : 11.60 MHz 802.11g : 18.45 MHz 802.11n HT20 : 19.25 MHz</p> <p><Ant. 2> 802.11b : 11.70 MHz 802.11g : 18.45 MHz 802.11n HT20 : 19.25 MHz</p> <p>MIMO <Ant. 1> 802.11g : 18.40 MHz 802.11n HT20 : 19.15 MHz</p> <p>MIMO <Ant. 2> 802.11g : 18.30 MHz 802.11n HT20 : 19.00 MHz</p>												
Antenna Type / Gain	<p><Ant 1> Fixed Internal Antenna type with gain 4.40 dBi</p> <p><Ant 2> Fixed Internal Antenna type with gain 4.68 dBi</p>												
Type of Modulation	802.11b : DSSS (DBPSK / DQPSK / CCK) 802.11g/n : OFDM (BPSK / QPSK / 16QAM / 64QAM)												
Antenna Function for Transmitter	<table border="1"> <thead> <tr> <th></th> <th>Ant. 1</th> <th>Ant. 2</th> </tr> </thead> <tbody> <tr> <td>802.11 b/g/n</td> <td>V</td> <td>V</td> </tr> <tr> <td>802.11 n</td> <td>V</td> <td>V</td> </tr> <tr> <td>MIMO</td> <td>V</td> <td>V</td> </tr> </tbody> </table>		Ant. 1	Ant. 2	802.11 b/g/n	V	V	802.11 n	V	V	MIMO	V	V
	Ant. 1	Ant. 2											
802.11 b/g/n	V	V											
802.11 n	V	V											
MIMO	V	V											

Note: MIMO Ant. 1+2 is a calculated result from sum of the power MIMO Ant. 1 and MIMO Ant. 2.

1.4 Modification of EUT

No modifications are made to the EUT during all test items.



1.5 Testing Location

Sporton Lab is accredited to ISO 17025 by Taiwan Accreditation Foundation (TAF code : 1190) and the FCC designation No. TW0007 under the FCC 2.948(e) by Mutual Recognition Agreement (MRA) in FCC Test.

Test Site	SPORTON INTERNATIONAL INC.	
Test Site Location	No. 52, Hwa Ya 1 st Rd., Hwa Ya Technology Park, Kwei-Shan District, Tao Yuan City, Taiwan, R.O.C. TEL: +886-3-327-3456 FAX: +886-3-328-4978	
Test Site No.	Sporton Site No.	
	TH05-HY	CO05-HY

Note: The test site complies with ANSI C63.4 2014 requirement.

Test Site	SPORTON INTERNATIONAL INC.	
Test Site Location	No.58, Aly. 75, Ln. 564, Wenhua 3rd Rd. Guishan Dist, Taoyuan City, Taiwan (R.O.C.) TEL: +886-3-327-0868 FAX: +886-3-327-0855	
Test Site No.	Sporton Site No.	
	03CH12-HY	

Note: The test site complies with ANSI C63.4 2014 requirement.

1.6 Applicable Standards

According to the specifications of the manufacturer, the EUT must comply with the requirements of the following standards:

- ♦ FCC Part 15 Subpart C §15.247
- ♦ FCC KDB Publication No. 558074 D01 DTS Meas. Guidance v04
- ♦ FCC KDB 662911 D01 Multiple Transmitter Output v02r01.
- ♦ ANSI C63.10-2013

Remark: All test items were verified and recorded according to the standards and without any deviation during the test.



2 Test Configuration of Equipment Under Test

The EUT has been associated with peripherals and configuration operated in a manner tended to maximize its emission characteristics in a typical application. Frequency range investigated: conducted emission (150 kHz to 30 MHz) and radiated emission (9 kHz to the 10th harmonic of the highest fundamental frequency or to 40 GHz, whichever is lower). For radiated measurement, the pretesting was done for radiated with and without the TV and the worst case was reported, and then pre-scanned in three orthogonal panels, X, Y, Z, and the worst cases (X plane for Ant. 1, Z plane for Ant. 2, and Y plane for MIMO Ant. 1+2) were recorded in this report.

2.1 Carrier Frequency and Channel

Frequency Band	Channel	Freq. (MHz)	Channel	Freq. (MHz)
2400-2483.5 MHz	1	2412	8	2447
	2	2417	9	2452
	3	2422	10	2457
	4	2427	11	2472
	5	2432	12	2467
	6	2437	13	2472
	7	2442	-	-



2.2 Test Mode

Final test mode of conducted test items and radiated spurious emissions are considering the modulation and worse data rates as below table.

Single Antenna

Modulation	Data Rate
802.11b	1 Mbps
802.11g	6 Mbps
802.11n HT20	MCS0

MIMO Antenna

Modulation	Data Rate
802.11g	6 Mbps
802.11n HT20	MCS0

Test Cases	
AC Conducted Emission	Mode 1 :WLAN (2.4GHz) Link + Bluetooth Link + MPEG4 (4K HDR) + USB Cable 1 (Charger from Adapter)

2.3 Connection Diagram of Test System

<WLAN Tx Mode>

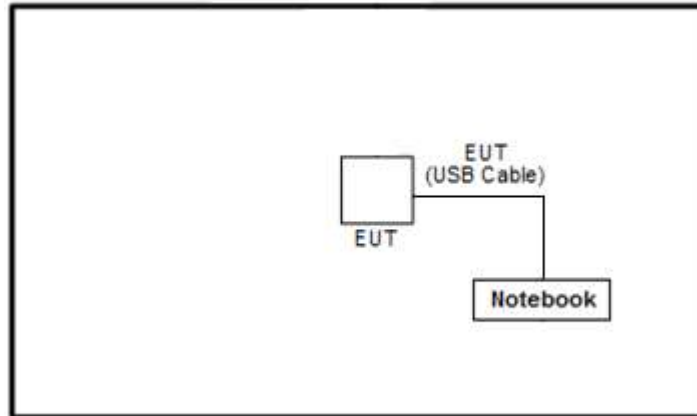

<AC Conducted Emission Mode>

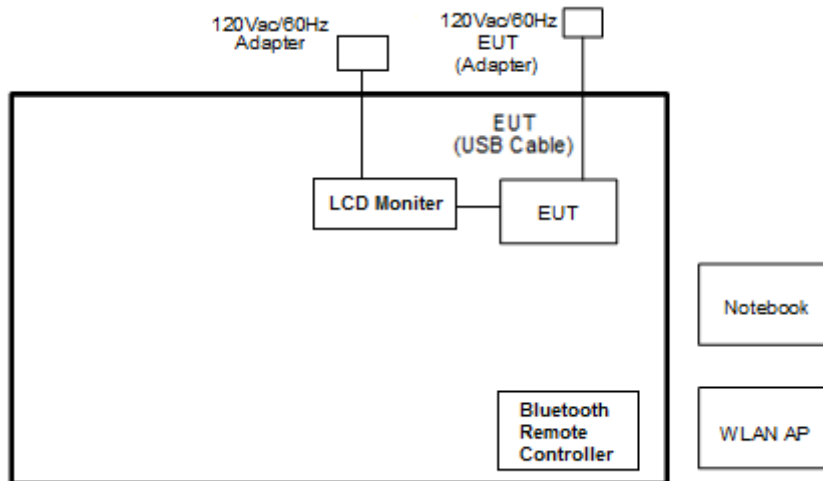



2.4 Support Unit used in test configuration and system

Item	Equipment	Trade Name	Model Name	FCC ID	Data Cable	Power Cord
1.	WLAN AP	ASUS	RT-AC66U	MSQ-RTAC66U	N/A	Unshielded, 1.8 m
2.	Notebook-40	Lenovo	E335	N/A	N/A	N/A
3.	Notebook	DELL	Latitude E6320	FCC DoC/ Contains FCC ID: QDS-BRCM1054	N/A	AC I/P: Unshielded, 1.2 m DC O/P: Shielded, 1.8 m
4.	LCD Monitor	Sony	KD-55X8500D	FCC DoC	Shielded, 1.6m	Unshielded,1.8m

2.5 EUT Operation Test Setup

The RF test items, programmed RF utility, “CMD” installed in the notebook make the EUT provide functions like channel selection and power level for continuous transmitting and receiving signals.

2.6 Measurement Results Explanation Example

For all conducted test items:

The offset level is set in the spectrum analyzer to compensate the RF cable loss and attenuator factor between EUT conducted output port and spectrum analyzer. With the offset compensation, the spectrum analyzer reading level is exactly the EUT RF output level.

Example:

The spectrum analyzer offset is derived from RF cable loss and attenuator factor.

Offset = RF cable loss + attenuator factor.

Following shows an offset computation example with cable loss 4.2 dB and 10dB attenuator.

Offset(dB) = RF cable loss(dB) + attenuator factor(dB).

= 4.2 + 10 = 14.2 (dB)

3 Test Result

3.1 6dB and 99% Bandwidth Measurement

3.1.1 Limit of 6dB and 99% Bandwidth

The minimum 6 dB bandwidth shall be at least 500 kHz.

3.1.2 Measuring Instruments

The measuring equipment is listed in the section 4 of this test report.

3.1.3 Test Procedures

1. The testing follows FCC KDB Publication No. 558074 DTS D01 Meas. Guidance v04.
2. The RF output of EUT was connected to the spectrum analyzer by RF cable and attenuator. The path loss was compensated to the results for each measurement.
3. Set to the maximum power setting and enable the EUT transmit continuously.
4. Make the measurement with the spectrum analyzer's resolution bandwidth (RBW) = 100 kHz. Set the Video bandwidth (VBW) = 300 kHz. In order to make an accurate measurement. The 6 dB bandwidth must be greater than 500 kHz.
5. For 99% Bandwidth Measurement, the spectrum analyzer's resolution bandwidth (RBW) = 1MHz and set the Video bandwidth (VBW) = 3MHz.
6. Measure and record the results in the test report.

3.1.4 Test Setup





3.1.5 Test Result of 6dB and 99% Occupied Bandwidth

Please refer to Appendix A.

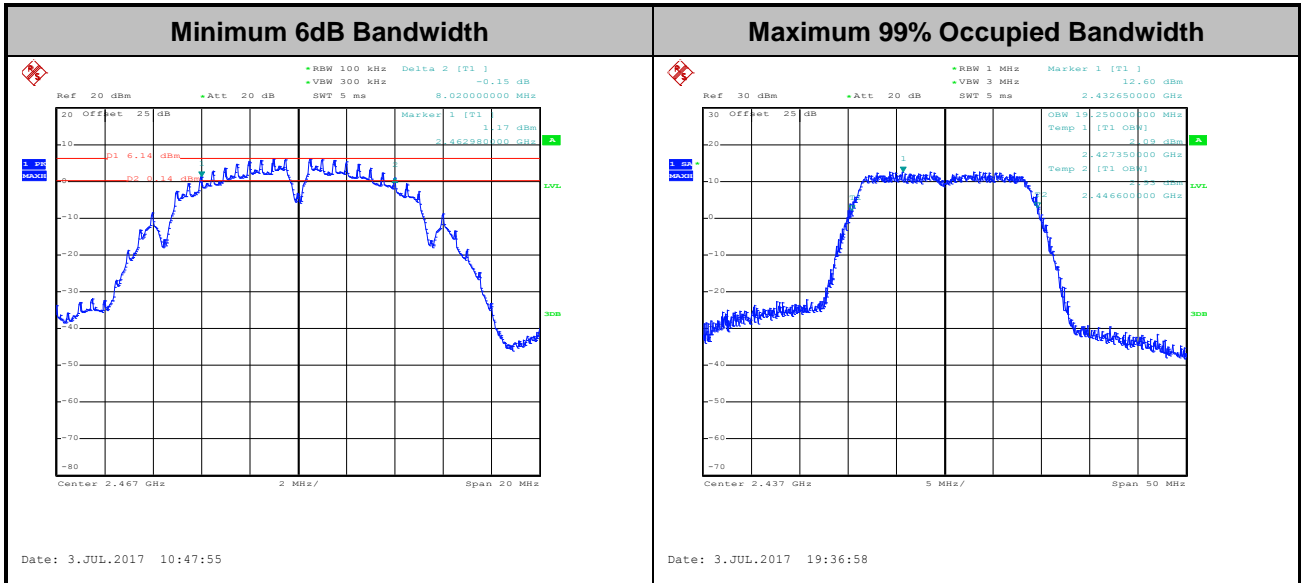

Note : The occupied channel bandwidth is maintained within the band of operation for all of the modulations.

3.2 Peak Output Power Measurement

3.2.1 Limit of Peak Output Power

For systems using digital modulation in the 2400-2483.5MHz, the limit for peak output power is 30dBm. If transmitting antenna with directional gain greater than 6dBi is used, the peak output power from the intentional radiator shall be reduced below the above stated value by the amount in dB that the directional gain of the antenna exceeds 6 dBi. In case of point-to-point operation, the limit has to be reduced by 1dB for every 3dB that the directional gain of the antenna exceeds 6dBi.

3.2.2 Measuring Instruments

The measuring equipment is listed in the section 4 of this test report.

3.2.3 Test Procedures

1. The testing follows the Measurement Procedure of FCC KDB No. 558074 DTS D01 Meas. Guidance v04 section 9.1.3 PKPM1 Peak power meter method.
2. The RF output of EUT was connected to the power meter by RF cable and attenuator. The path loss was compensated to the results for each measurement.
3. Set to the maximum power setting and enable the EUT transmit continuously.
4. Measure the conducted output power and record the results in the test report.
5. For MIMO mode, calculation method follows FCC KDB 662911 D01 Multiple Transmitter Output v02r01.

3.2.4 Test Setup

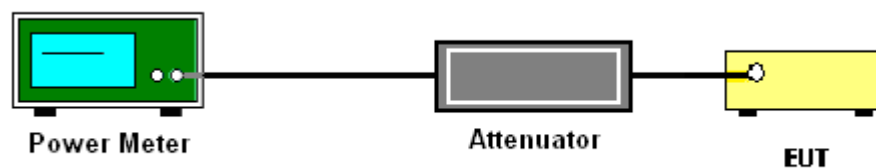

3.2.5 Test Result of Peak Output Power

Please refer to Appendix A.

3.2.6 Test Result of Average output Power (Reporting Only)

Please refer to Appendix A



3.3 Power Spectral Density Measurement

3.3.1 Limit of Power Spectral Density

The peak power spectral density shall not be greater than 8dBm in any 3kHz band at any time interval of continuous transmission.

3.3.2 Measuring Instruments

The measuring equipment is listed in the section 4 of this test report.

3.3.3 Test Procedures

1. The testing follows Measurement Procedure 10.2 Method PKPSD of FCC KDB Publication No. 558074 D01 DTS Meas. Guidance v04.
2. The RF output of EUT was connected to the spectrum analyzer by RF cable and attenuator. The path loss was compensated to the results for each measurement.
3. Set to the maximum power setting and enable the EUT transmit continuously.
4. Make the measurement with the spectrum analyzer's resolution bandwidth (RBW) = 3 kHz. Video bandwidth VBW = 10 kHz In order to make an accurate measurement, set the span to 1.5 times DTS Channel Bandwidth. (6dB BW)
5. Detector = peak, Sweep time = auto couple, Trace mode = max hold, Allow trace to fully stabilize. Use the peak marker function to determine the maximum power level.
6. Measure and record the results in the test report.
7. For MIMO mode, calculation method follows FCC KDB 662911 D01 Multiple Transmitter Output v02r01.

If measurements performed using method (2) plus $10 \log(N)$ exceeds the emission limit, the test should choose method (1) before declaring that the device fails the emission limit.

Method (1): Measure and sum the spectra across the outputs.

The total final Power Spectral Density is from a device with 2 transmitter outputs. The spectrum measurements of the individual outputs are all performed with the same span and number of points, the spectrum value in the first spectral bin of output 1 is summed with that in the first spectral bin of output 2 to obtain the value for the first frequency bin of the summed spectrum.

Method (2): Measure and add $10 \log(N)$ dB, where N is the number of outputs. (N=2)

3.3.4 Test Setup

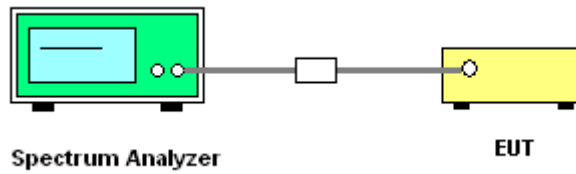

3.3.5 Test Result of Power Spectral Density

Please refer to Appendix A.

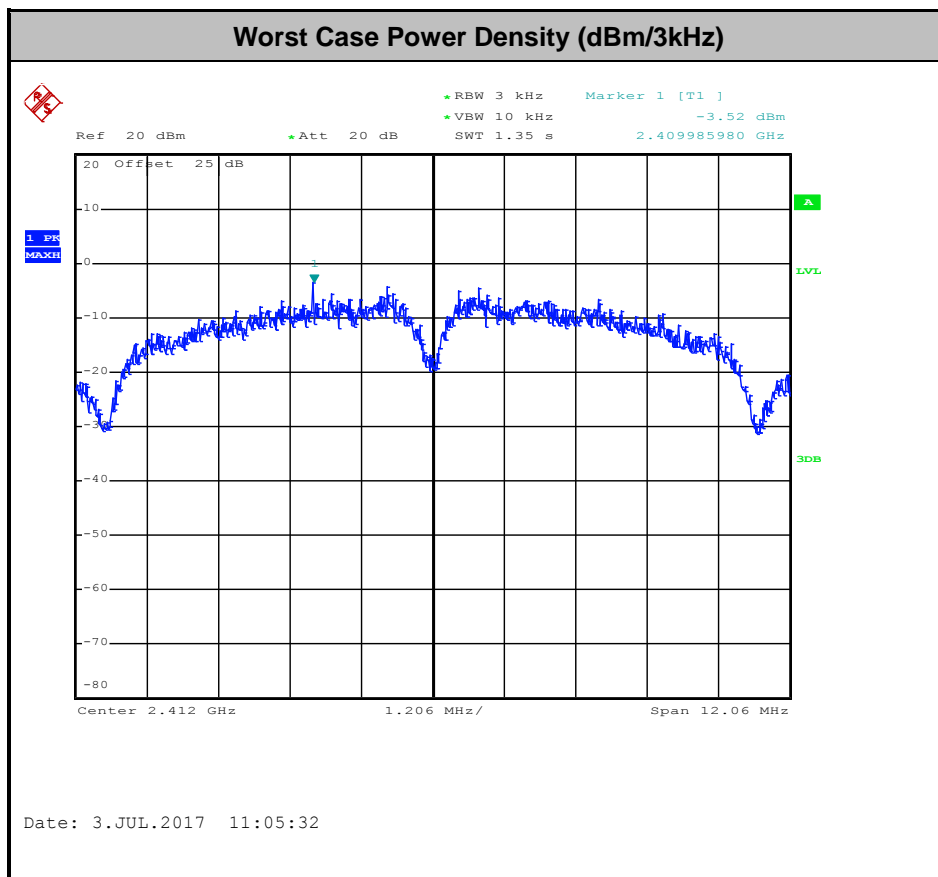

3.4 Conducted Band Edges and Spurious Emission Measurement

3.4.1 Limit of Conducted Band Edges and Spurious Emission Measurement

In any 100 kHz bandwidth outside of the authorized frequency band, the emissions which fall in the non-restricted bands shall be attenuated at least 20 dB / 30dB relative to the maximum PSD level in 100 kHz by RF conducted measurement.

3.4.2 Measuring Instruments

The measuring equipment is listed in the section 4 of this test report.

3.4.3 Test Procedures

1. The testing follows FCC KDB Publication No. 558074 D01 DTS Meas. Guidance v04.
2. The RF output of EUT was connected to the spectrum analyzer by RF cable and attenuator. The path loss was compensated to the results for each measurement.
3. Set to the maximum power setting and enable the EUT transmit continuously.
4. Set RBW = 100 kHz, VBW=300 kHz, Peak Detector. Unwanted Emissions measured in any 100 kHz bandwidth outside of the authorized frequency band shall be attenuated by at least 20 dB relative to the maximum in-band peak PSD level in 100 kHz when maximum peak conducted output power procedure is used. If the transmitter complies with the conducted power limits based on the use of RMS averaging over a time interval, the attenuation required under this paragraph shall be 30 dB instead of 20 dB.
5. Measure and record the results in the test report.
6. The RF fundamental frequency should be excluded against the limit line in the operating frequency band.

3.4.4 Test Setup

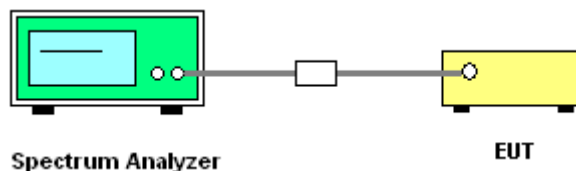



3.4.5 Test Result of Conducted Band Edges and Spurious Emission

Number of TX = 1, Ant. 1 (Measured)

Number of TX	1	Ant. :	1
Test Mode :	802.11b	Temperature :	21~25°C
Test Band :	2.4GHz Low	Relative Humidity :	51~54%
Test Channel :	01	Test Engineer :	Tommy Lee / Aking Chang

WLAN 802.11b Channel 01

100kHz PSD reference Level

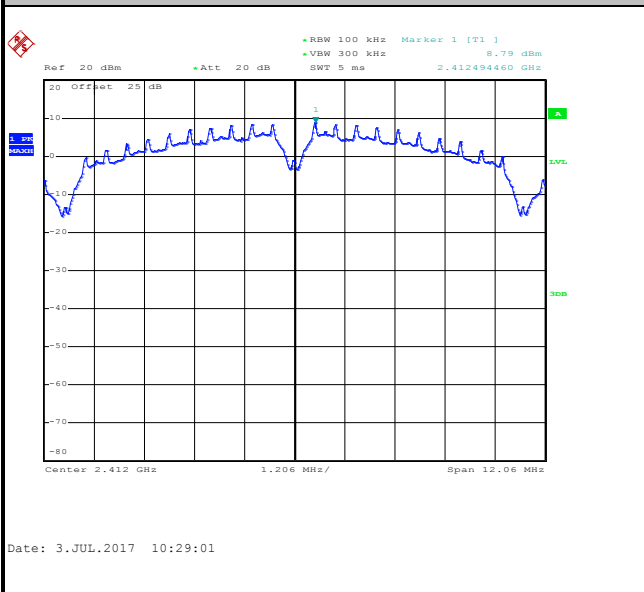

Low Channel Plot

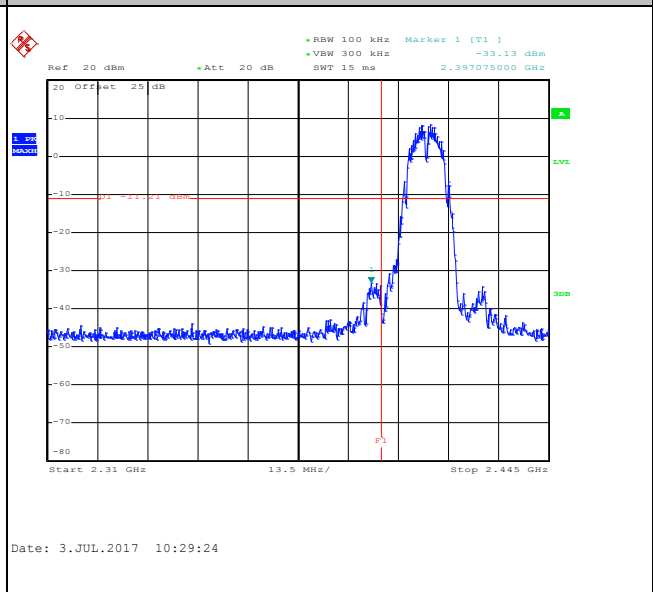

Spurious Emission 30MHz~3GHz

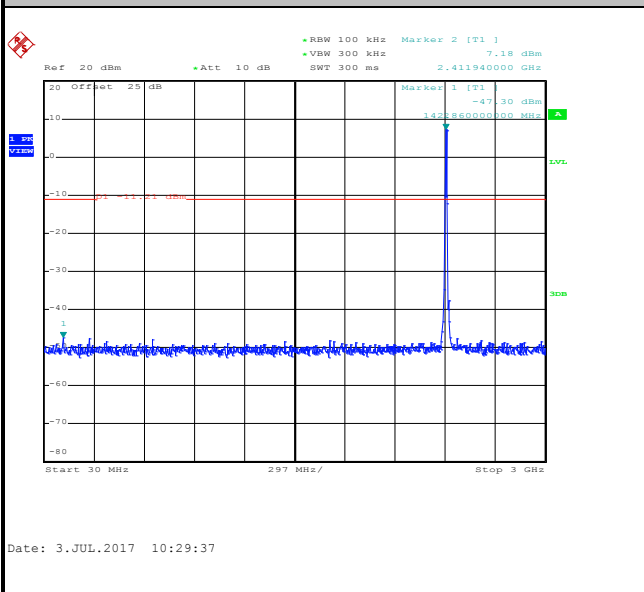

Spurious Emission 2GHz~25GHz

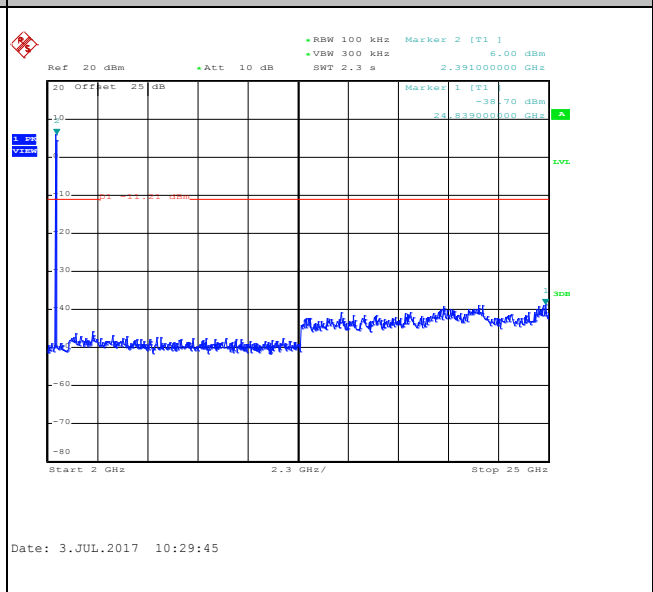



Number of TX :	1	Ant. :	1
Test Mode :	802.11b	Temperature :	21~25°C
Test Band :	2.4GHz Mid	Relative Humidity :	51~54%
Test Channel :	06	Test Engineer :	Tommy Lee / Aking Chang

WLAN 802.11b Channel 06

100kHz PSD reference Level

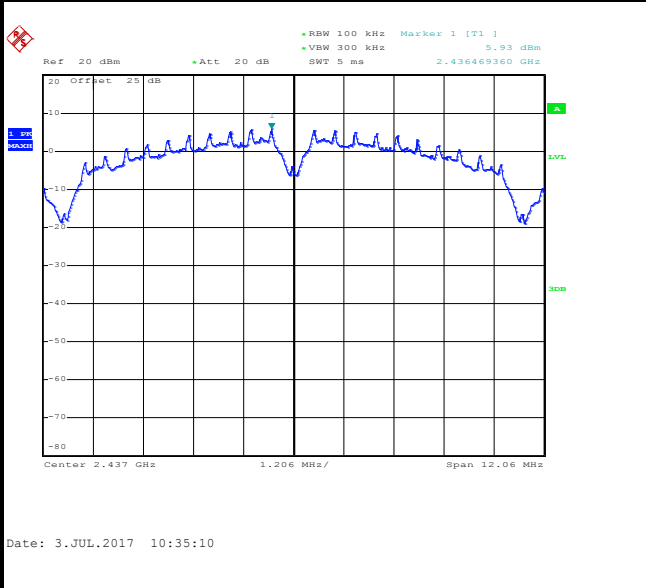

Spurious Emission 30MHz~3GHz

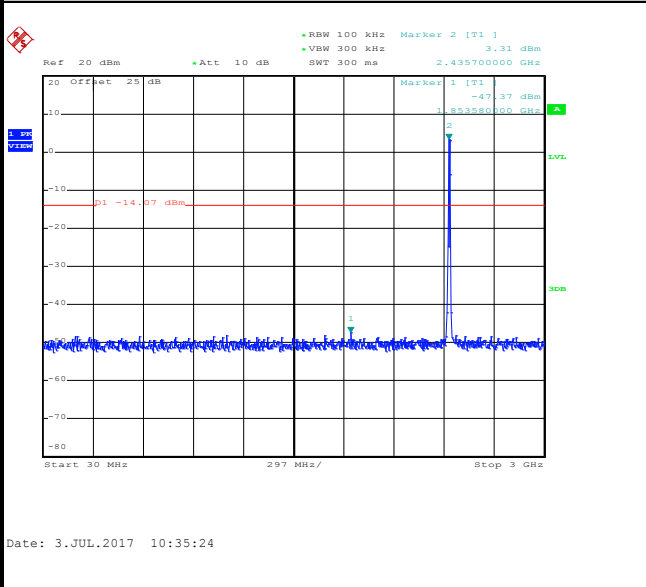

Spurious Emission 2GHz~25GHz

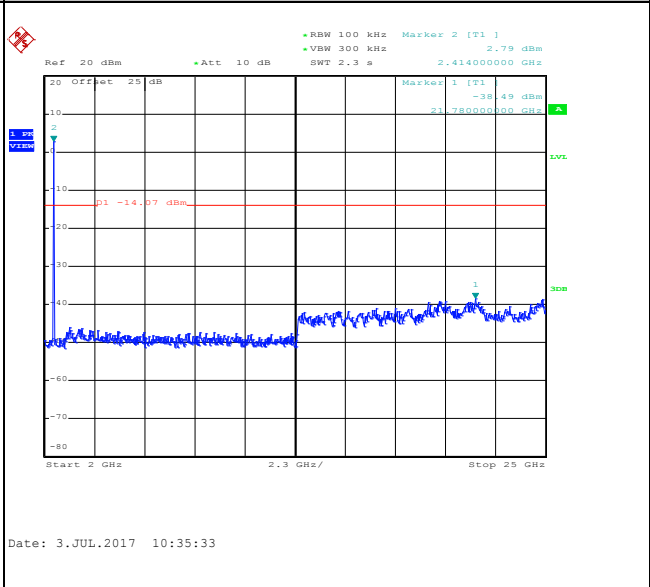



Number of TX :	1	Ant. :	1
Test Mode :	802.11b	Temperature :	21~25°C
Test Band :	2.4GHz High	Relative Humidity :	51~54%
Test Channel :	11	Test Engineer :	Tommy Lee / Aking Chang

WLAN 802.11b Channel 11

100kHz PSD reference Level

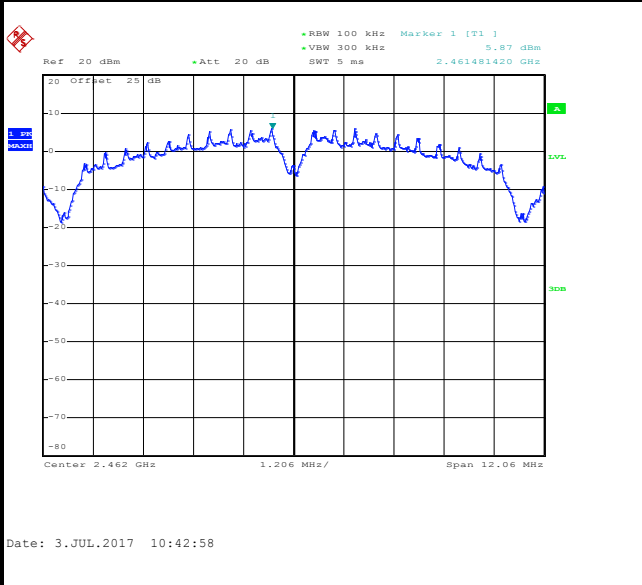

High Channel Plot

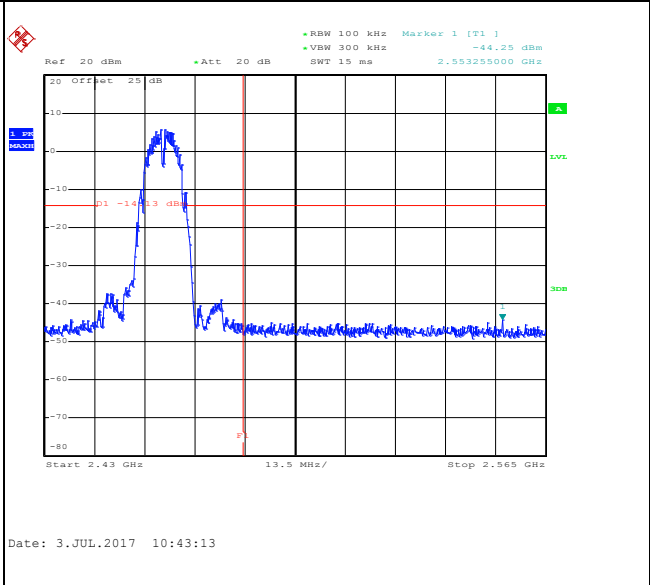

Spurious Emission 30MHz~3GHz

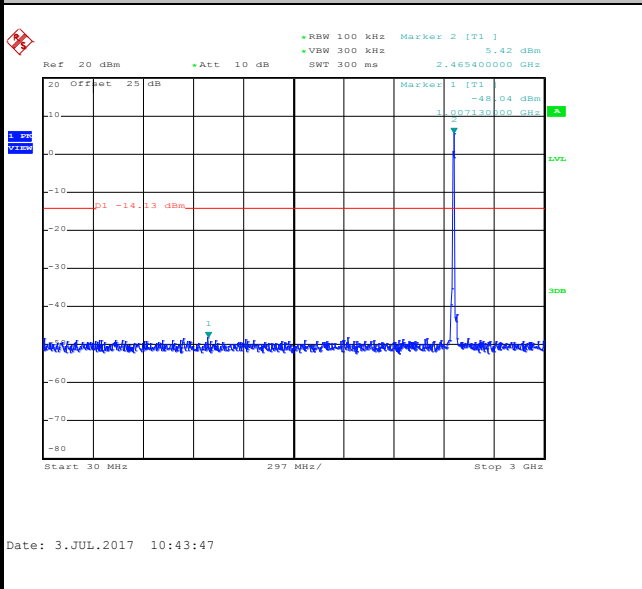

Spurious Emission 2GHz~25GHz

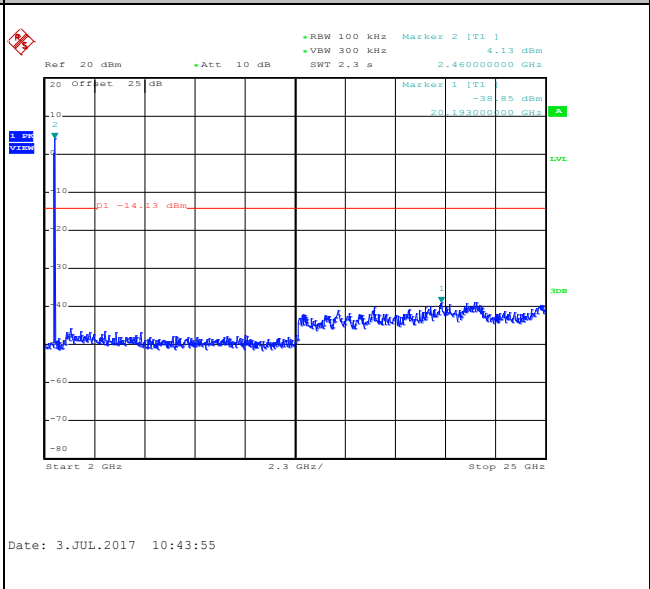



Number of TX :	1	Ant. :	1
Test Mode :	802.11b	Temperature :	21~25°C
Test Band :	2.4GHz High	Relative Humidity :	51~54%
Test Channel :	12	Test Engineer :	Tommy Lee / Aking Chang

WLAN 802.11b Channel 12

100kHz PSD reference Level

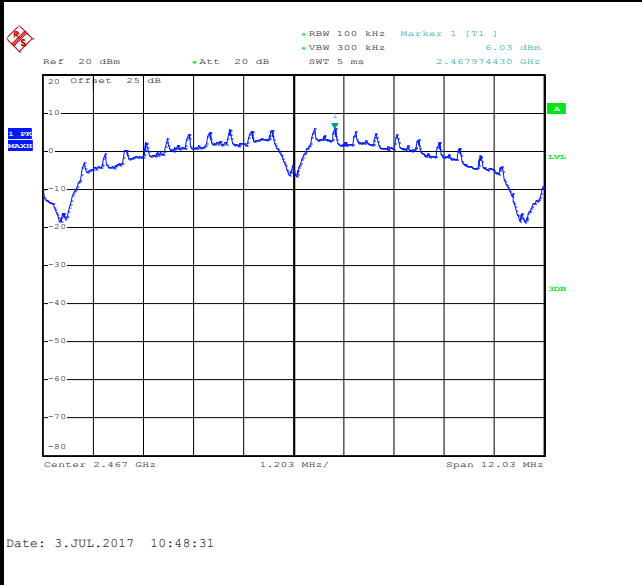

High Channel Plot

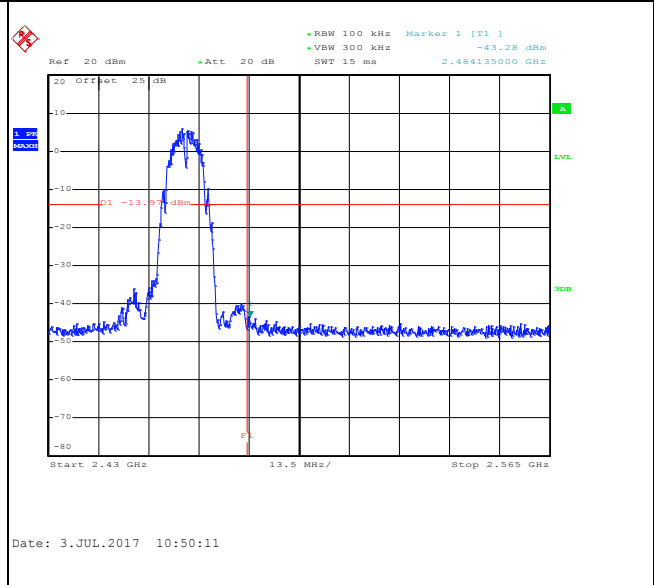

Spurious Emission 30MHz~3GHz

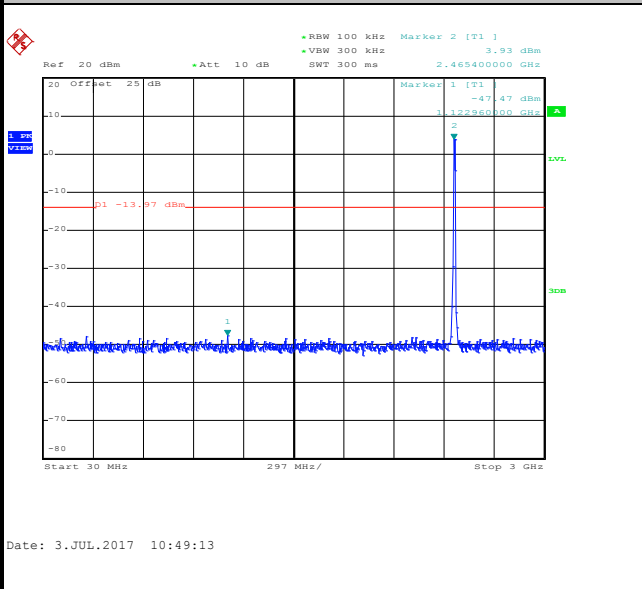

Spurious Emission 2GHz~25GHz

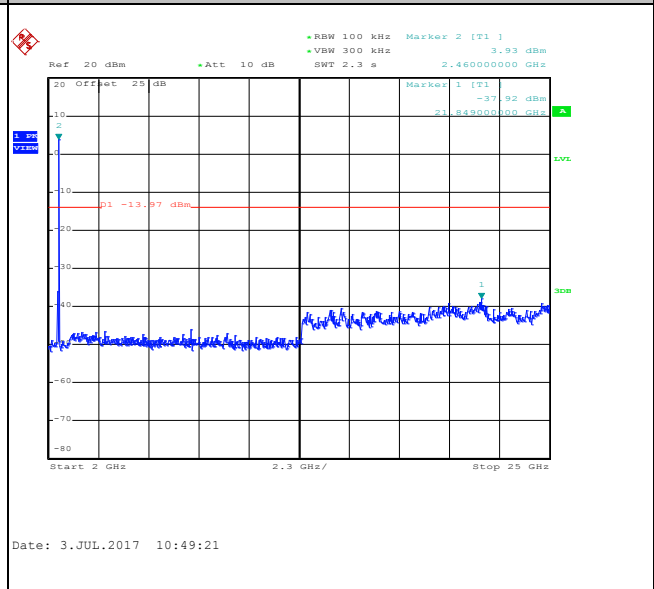



Number of TX :	1	Ant. :	1
Test Mode :	802.11b	Temperature :	21~25°C
Test Band :	2.4GHz High	Relative Humidity :	51~54%
Test Channel :	13	Test Engineer :	Tommy Lee / Aking Chang

WLAN 802.11b Channel 13

100kHz PSD reference Level

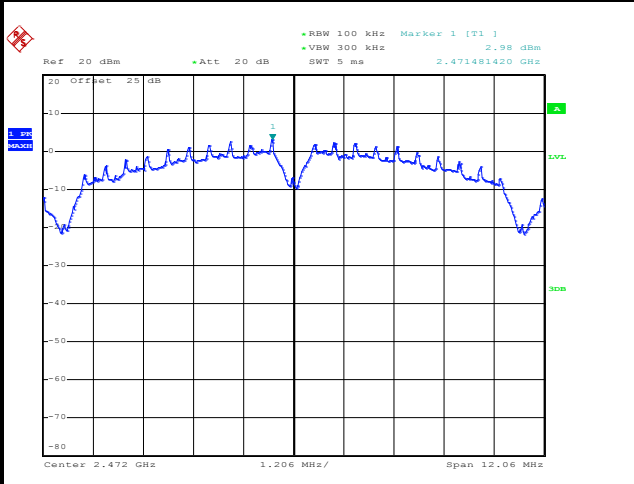

Date: 3.JUL.2017 10:56:32

High Channel Plot

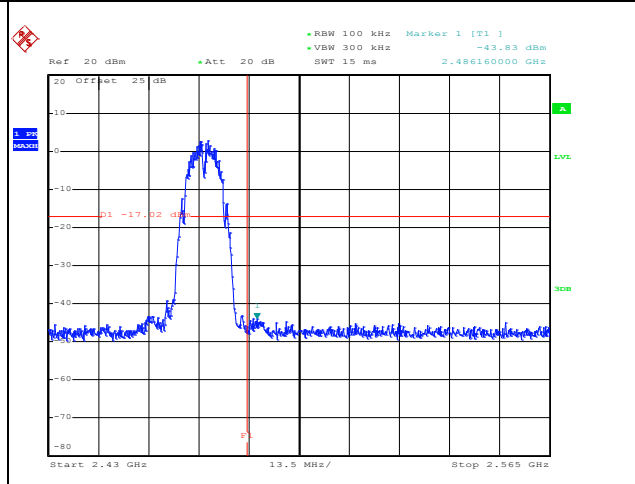

Date: 3.JUL.2017 10:56:49

Spurious Emission 30MHz~3GHz

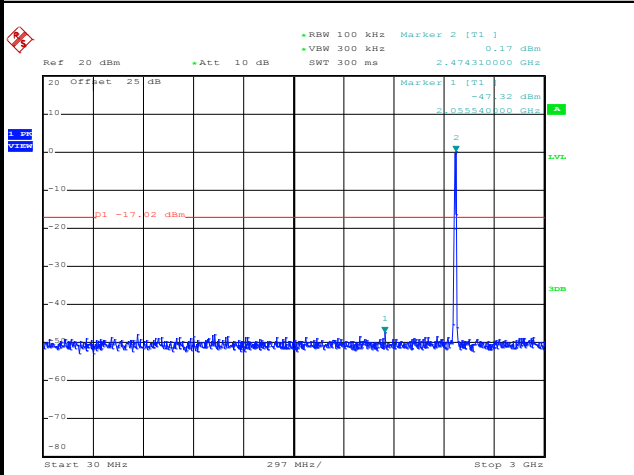

Date: 3.JUL.2017 10:57:34

Spurious Emission 2GHz~25GHz

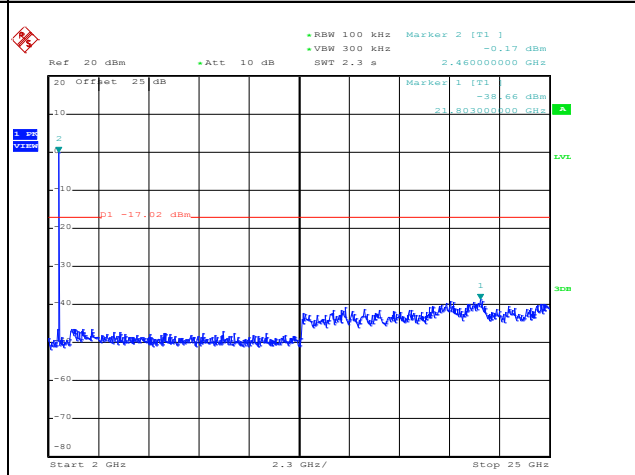

Date: 3.JUL.2017 10:57:42



Number of TX :	1	Ant. :	1
Test Mode :	802.11g	Temperature :	21~25°C
Test Band :	2.4GHz Low	Relative Humidity :	51~54%
Test Channel :	01	Test Engineer :	Tommy Lee / Aking Chang

WLAN 802.11g Channel 01

100kHz PSD reference Level

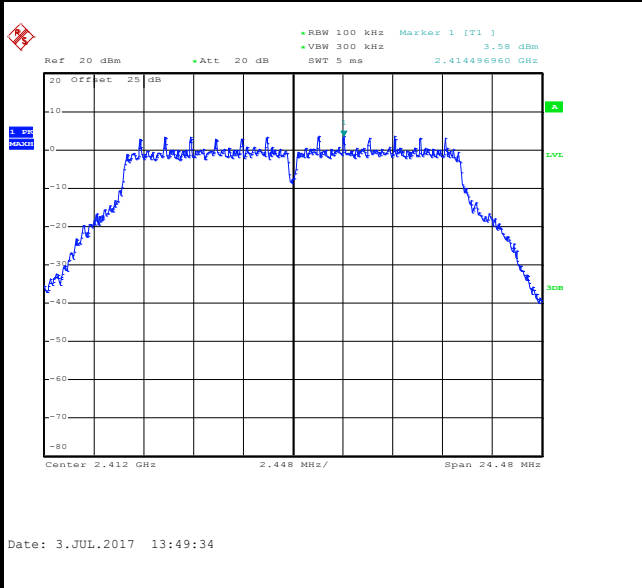

Low Channel Plot

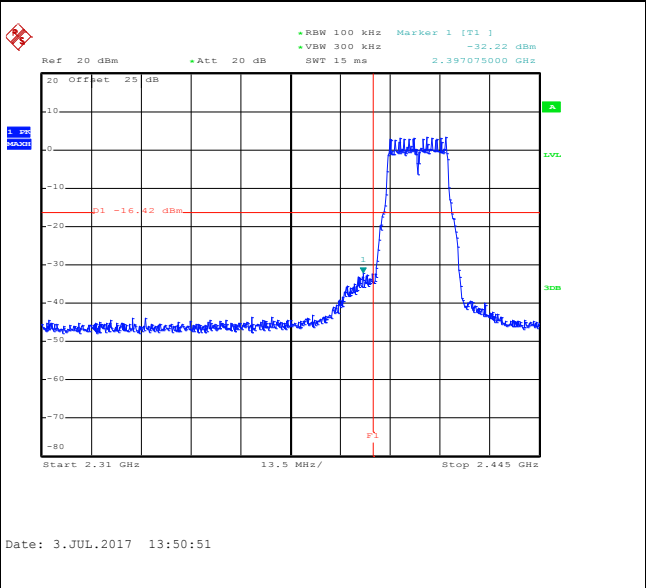

Spurious Emission 30MHz~3GHz

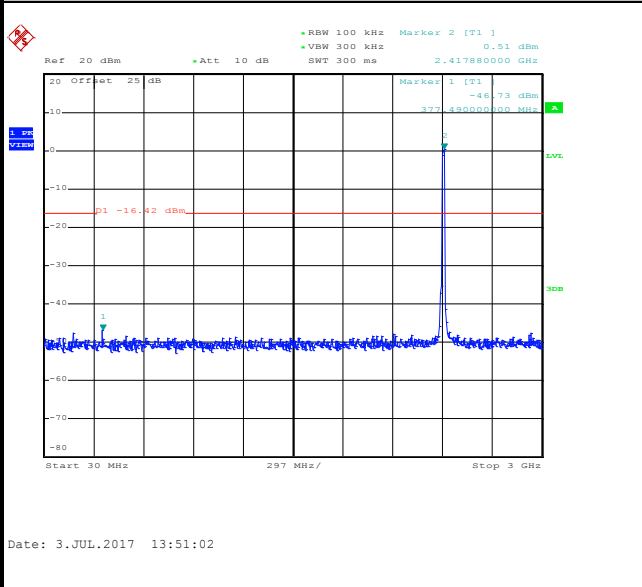

Spurious Emission 2GHz~25GHz

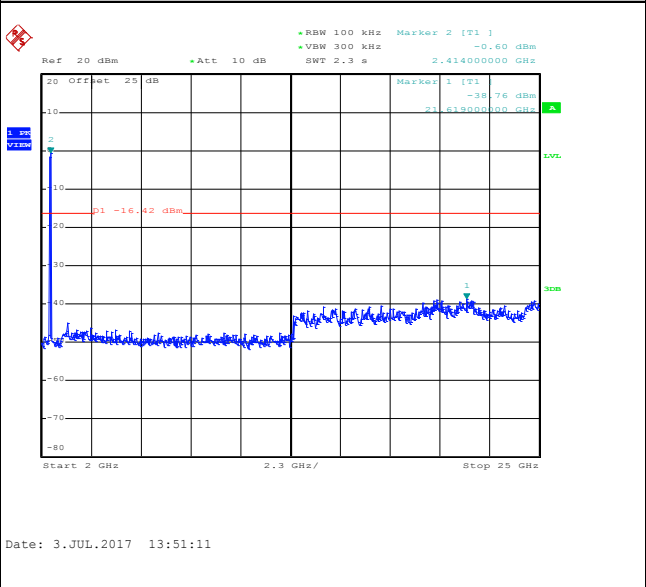



Number of TX :	1	Ant. :	1
Test Mode :	802.11g	Temperature :	21~25°C
Test Band :	2.4GHz Mid	Relative Humidity :	51~54%
Test Channel :	06	Test Engineer :	Tommy Lee / Aking Chang

WLAN 802.11g Channel 06

100kHz PSD reference Level

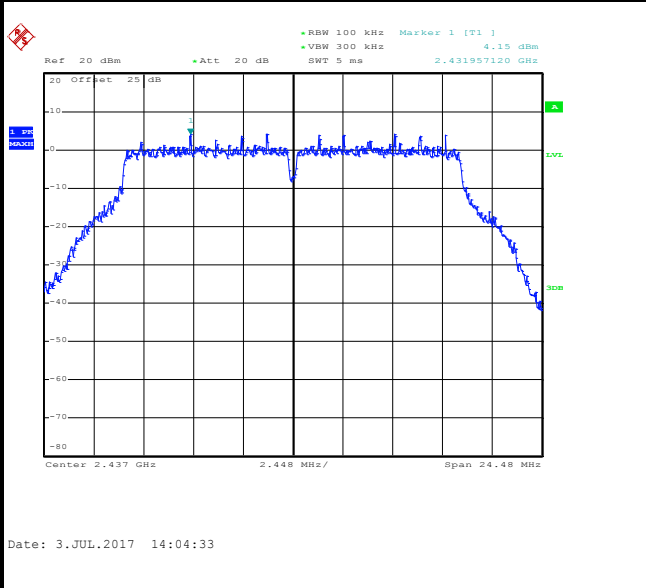

Spurious Emission 30MHz~3GHz

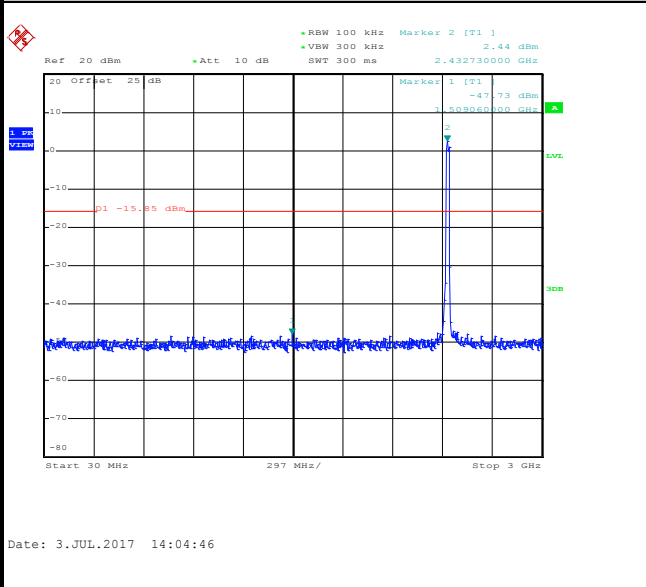

Spurious Emission 2GHz~25GHz

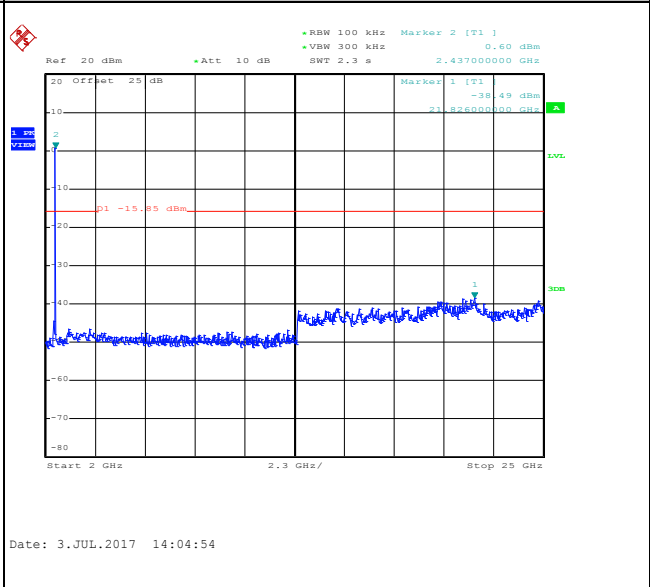



Number of TX :	1	Ant. :	1
Test Mode :	802.11g	Temperature :	21~25°C
Test Band :	2.4GHz High	Relative Humidity :	51~54%
Test Channel :	11	Test Engineer :	Tommy Lee / Aking Chang

WLAN 802.11g Channel 11

100kHz PSD reference Level

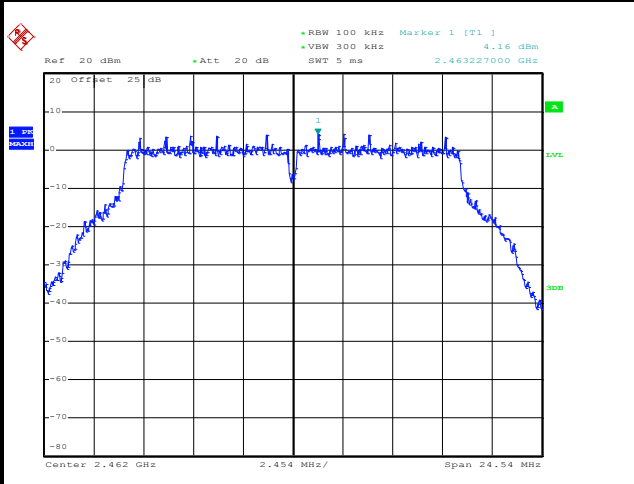

Date: 3.JUL.2017 14:18:33

High Channel Plot

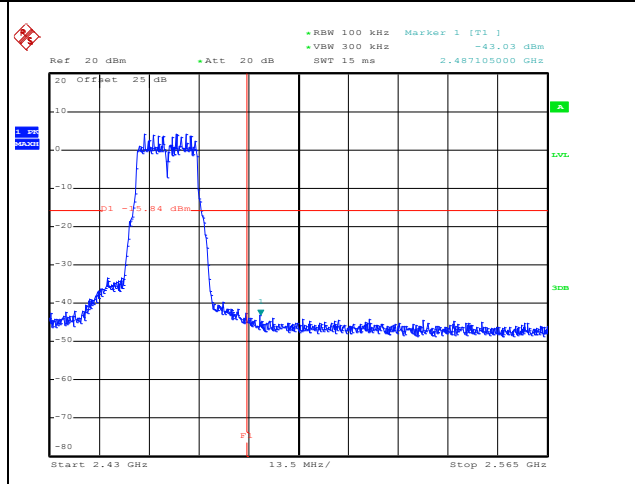

Date: 3.JUL.2017 14:18:59

Spurious Emission 30MHz~3GHz

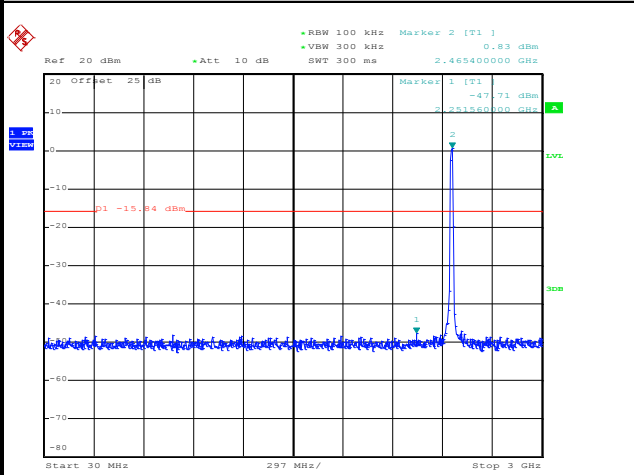

Date: 3.JUL.2017 14:19:11

Spurious Emission 2GHz~25GHz

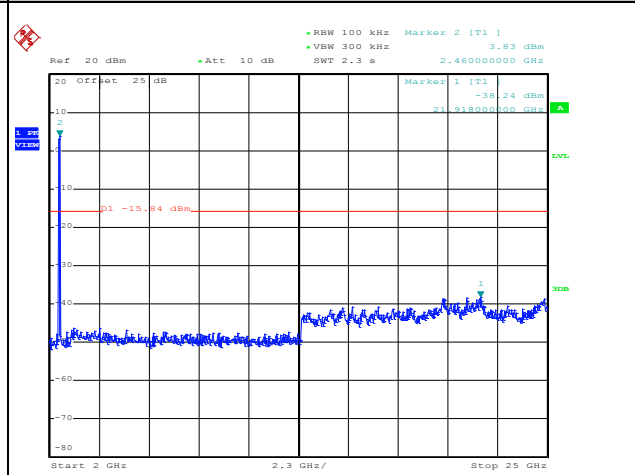

Date: 3.JUL.2017 14:19:20



Number of TX :	1	Ant. :	1
Test Mode :	802.11g	Temperature :	21~25°C
Test Band :	2.4GHz High	Relative Humidity :	51~54%
Test Channel :	12	Test Engineer :	Tommy Lee / Aking Chang

WLAN 802.11g Channel 12

100kHz PSD reference Level

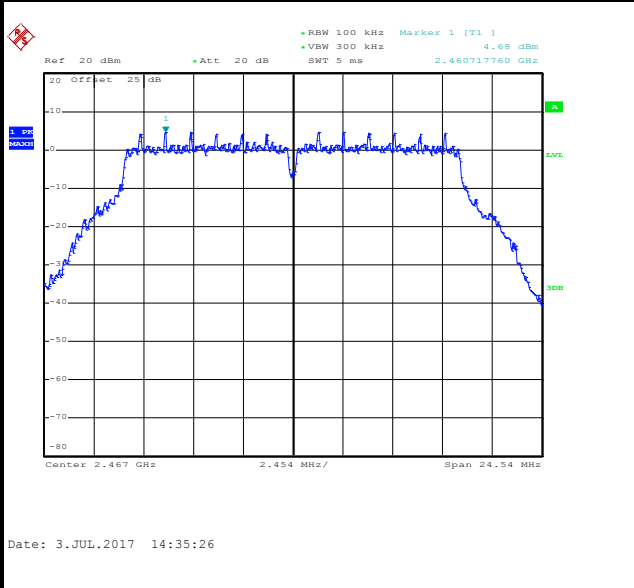

High Channel Plot

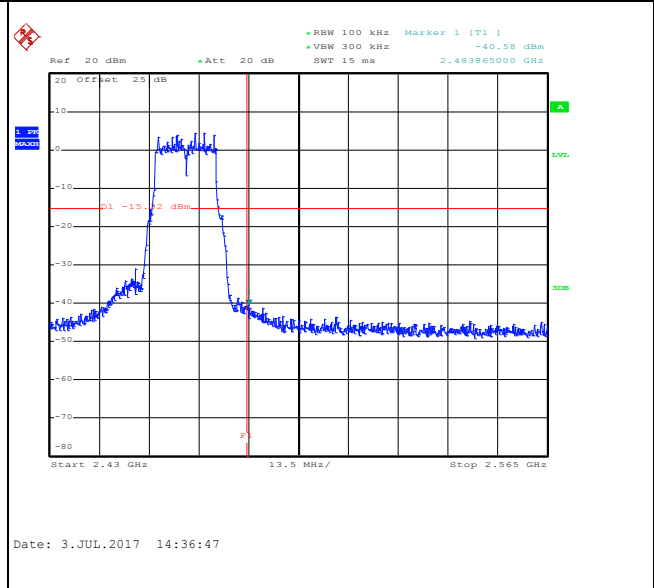

Spurious Emission 30MHz~3GHz

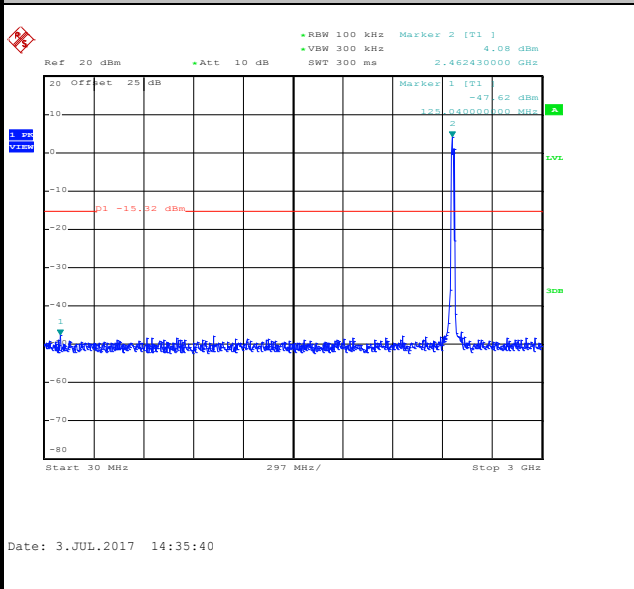

Spurious Emission 2GHz~25GHz

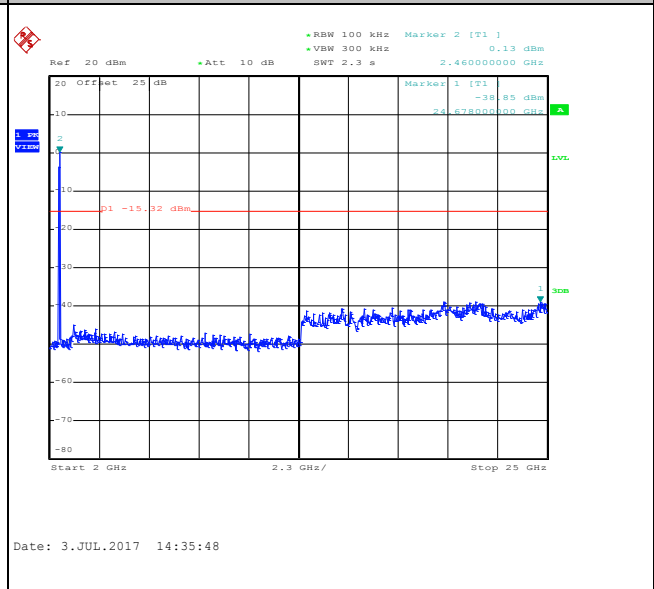



Number of TX :	1	Ant. :	1
Test Mode :	802.11g	Temperature :	21~25°C
Test Band :	2.4GHz High	Relative Humidity :	51~54%
Test Channel :	13	Test Engineer :	Tommy Lee / Aking Chang

WLAN 802.11g Channel 13

100kHz PSD reference Level

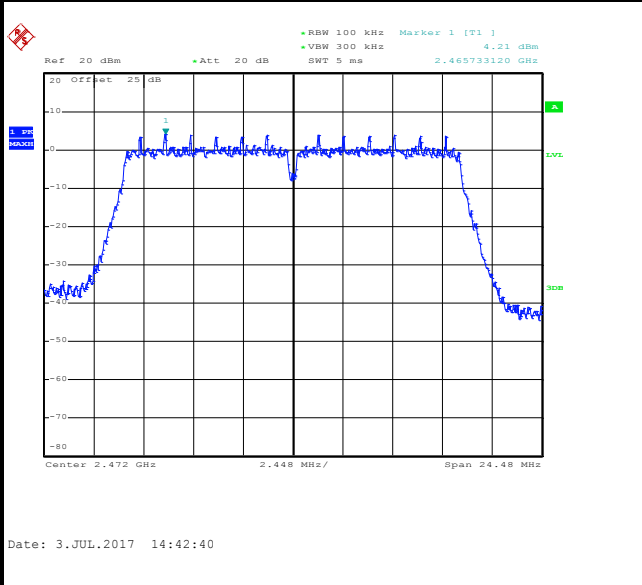

High Channel Plot

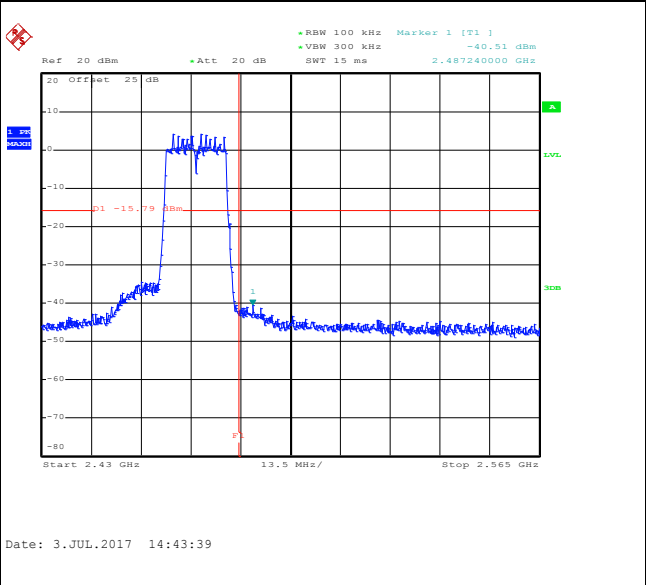

Spurious Emission 30MHz~3GHz

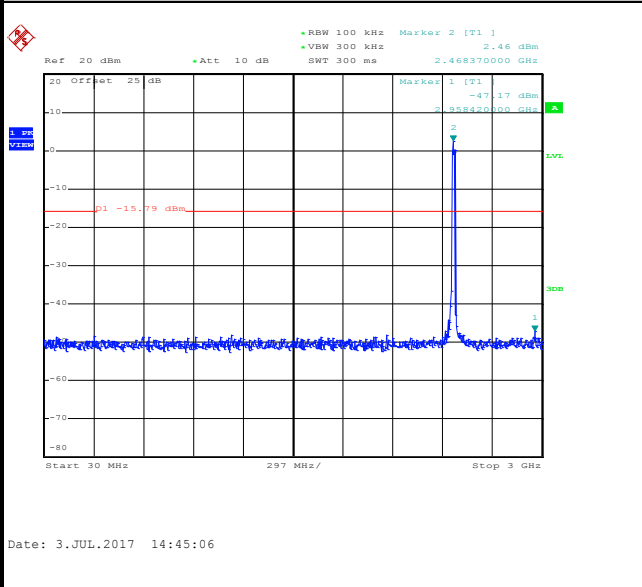

Spurious Emission 2GHz~25GHz

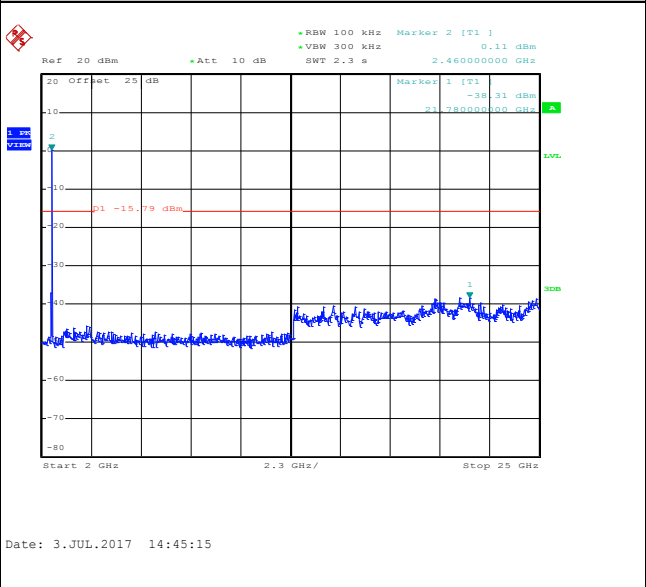



Number of TX :	1	Ant. :	1
Test Mode :	802.11n HT20	Temperature :	21~25°C
Test Band :	2.4GHz Low	Relative Humidity :	51~54%
Test Channel :	01	Test Engineer :	Tommy Lee / Aking Chang

WLAN 802.11n HT20 Channel 01

100kHz PSD reference Level

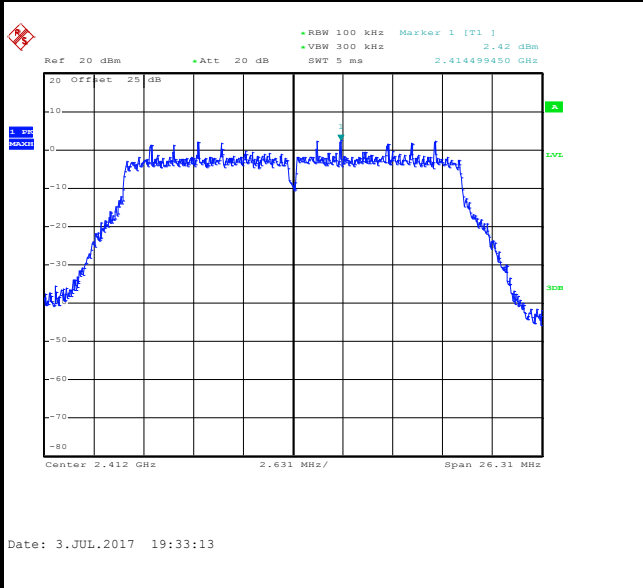

Low Channel Plot

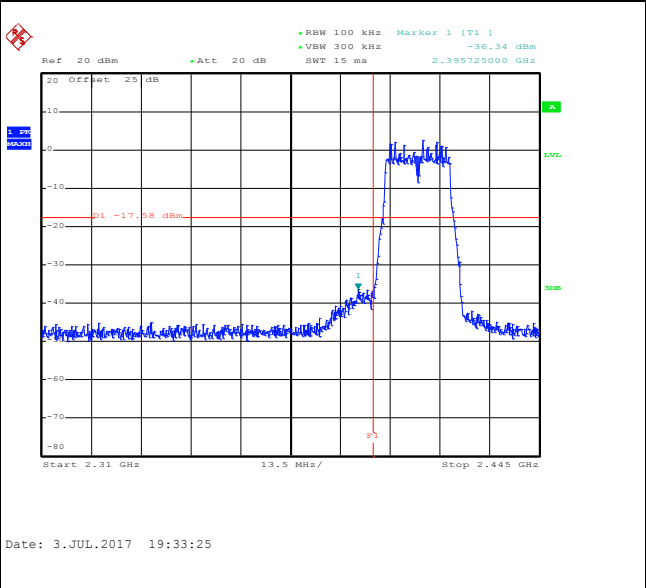

Spurious Emission 30MHz~3GHz

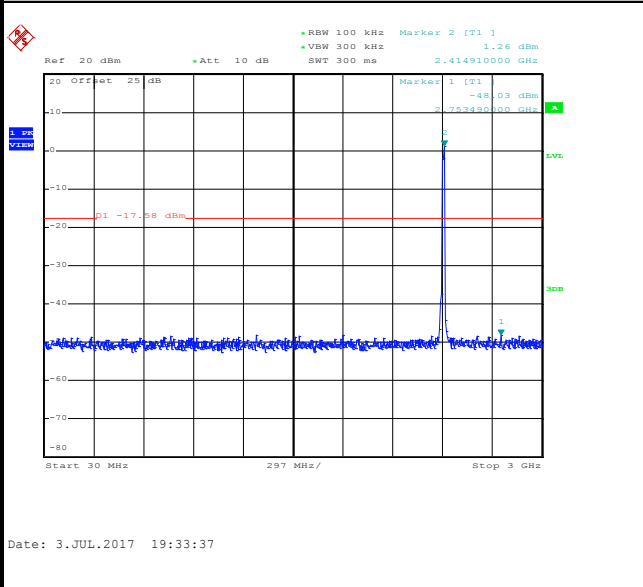

Spurious Emission 2GHz~25GHz

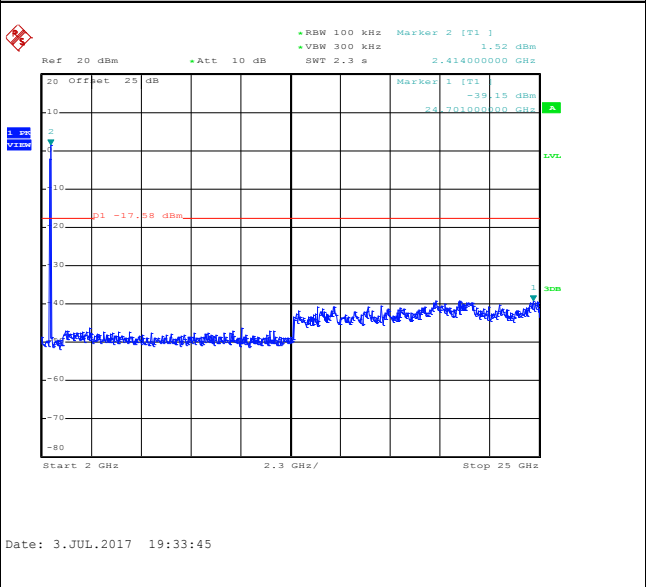



Number of TX :	1	Ant. :	1
Test Mode :	802.11n HT20	Temperature :	21~25°C
Test Band :	2.4GHz Mid	Relative Humidity :	51~54%
Test Channel :	06	Test Engineer :	Tommy Lee / Aking Chang

WLAN 802.11n HT20 Channel 06

100kHz PSD reference Level

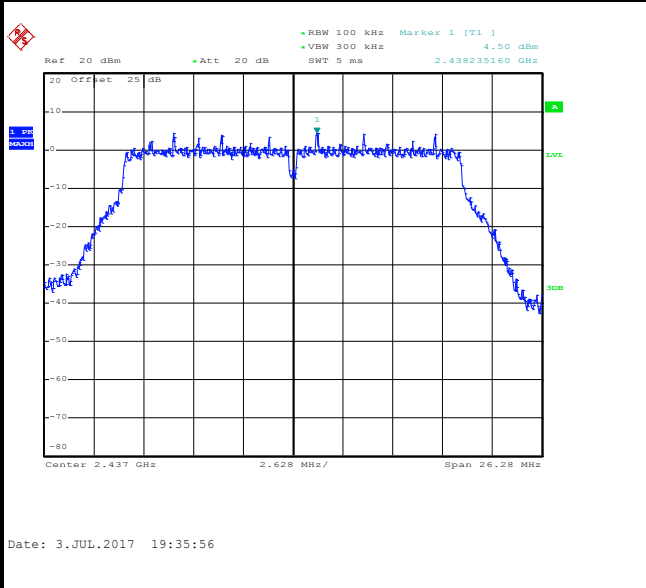

Spurious Emission 30MHz~3GHz

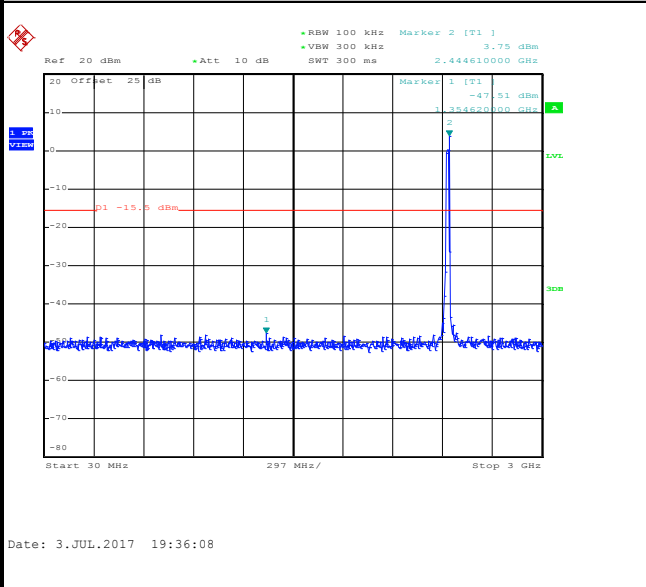

Spurious Emission 2GHz~25GHz

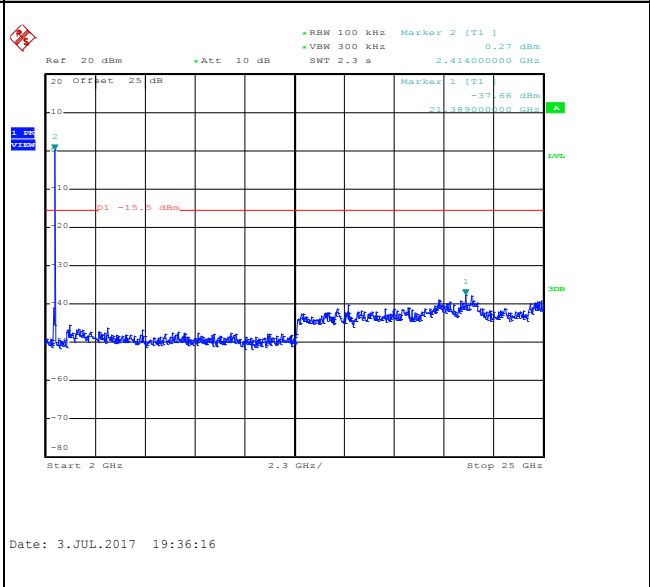



Number of TX :	1	Ant. :	1
Test Mode :	802.11n HT20	Temperature :	21~25°C
Test Band :	2.4GHz High	Relative Humidity :	51~54%
Test Channel :	11	Test Engineer :	Tommy Lee / Aking Chang

WLAN 802.11n HT20 Channel 11

100kHz PSD reference Level

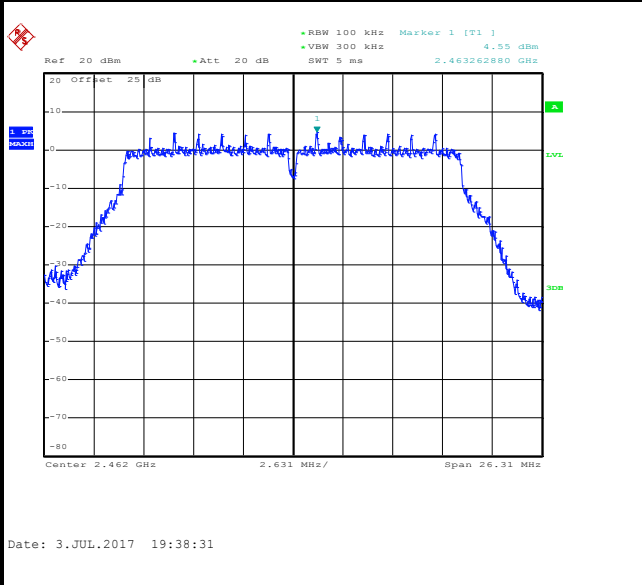

High Channel Plot

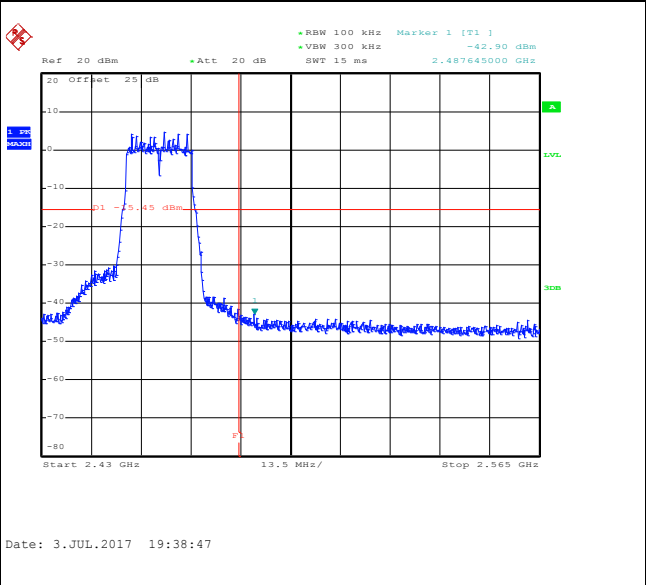

Spurious Emission 30MHz~3GHz

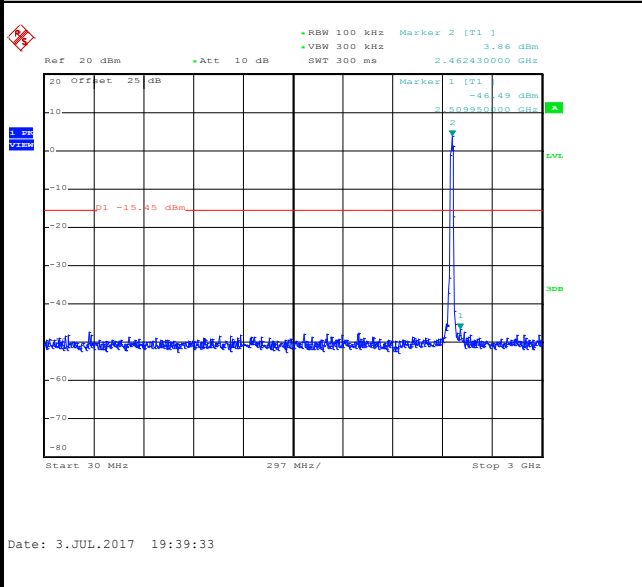

Spurious Emission 2GHz~25GHz

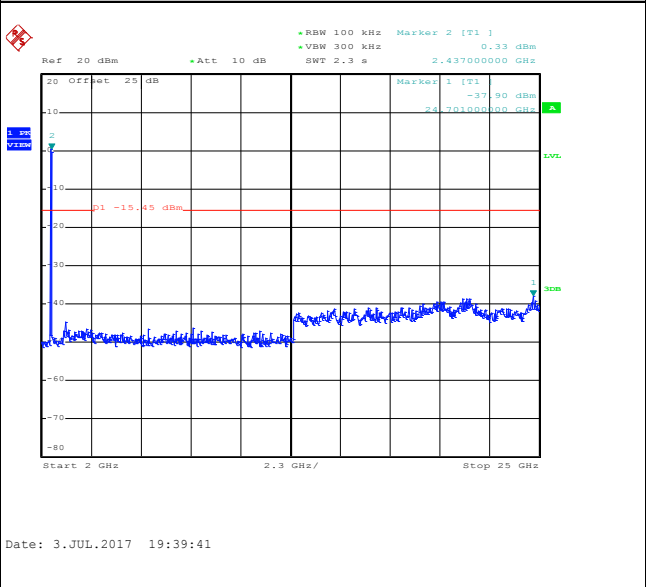



Number of TX :	1	Ant. :	1
Test Mode :	802.11n HT20	Temperature :	21~25°C
Test Band :	2.4GHz High	Relative Humidity :	51~54%
Test Channel :	12	Test Engineer :	Tommy Lee / Aking Chang

WLAN 802.11n HT20 Channel 12

100kHz PSD reference Level



High Channel Plot

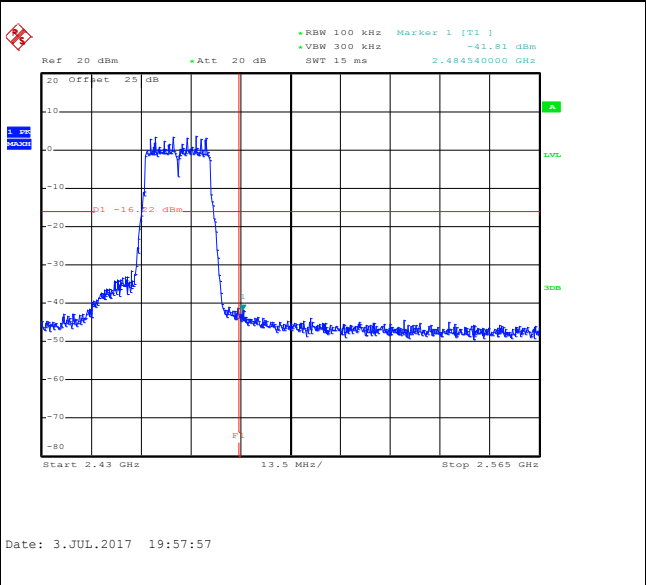

Spurious Emission 30MHz~3GHz

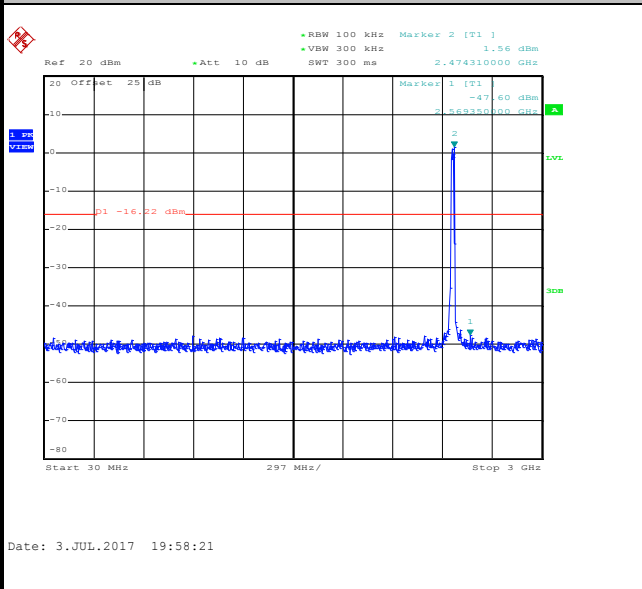

Spurious Emission 2GHz~25GHz

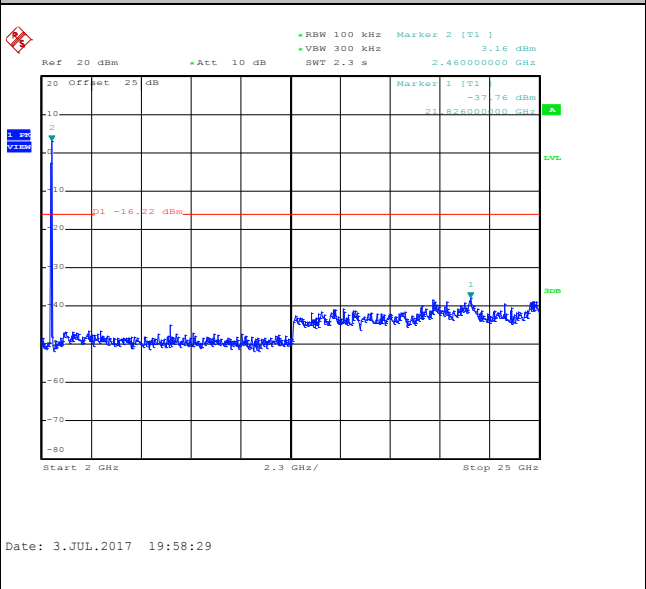



Number of TX :	1	Ant. :	1
Test Mode :	802.11n HT20	Temperature :	21~25°C
Test Band :	2.4GHz High	Relative Humidity :	51~54%
Test Channel :	13	Test Engineer :	Tommy Lee / Aking Chang

WLAN 802.11n HT20 Channel 13

100kHz PSD reference Level

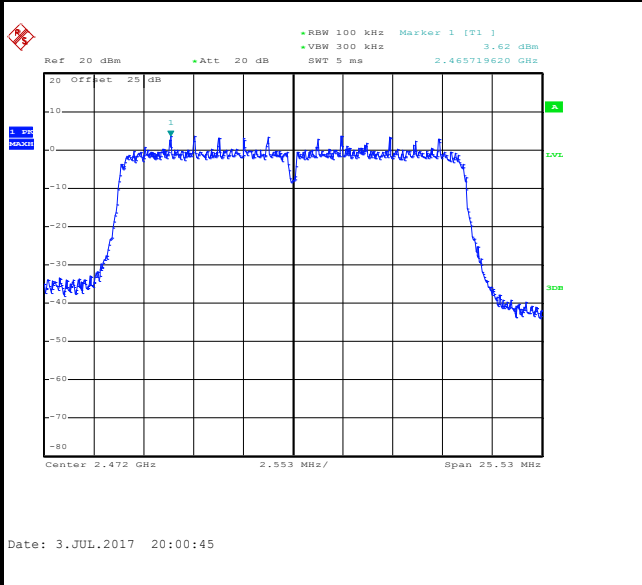

High Channel Plot

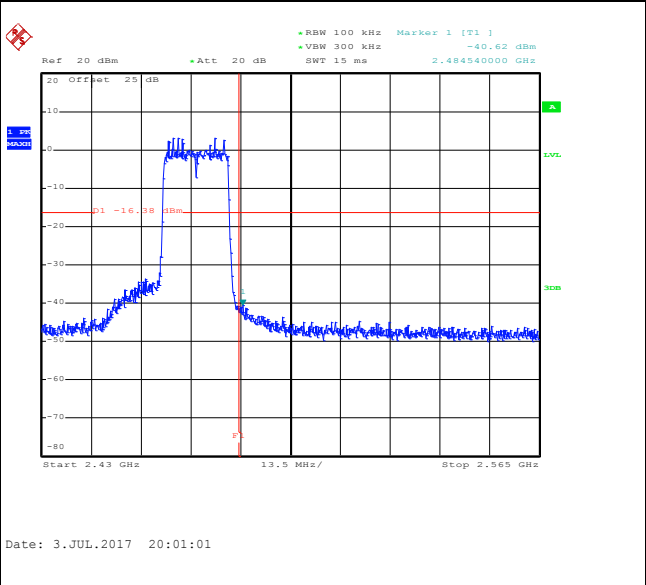

Spurious Emission 30MHz~3GHz

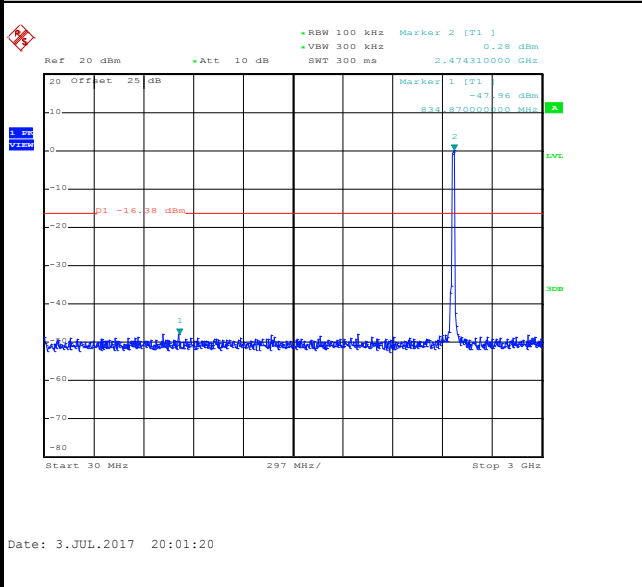

Spurious Emission 2GHz~25GHz

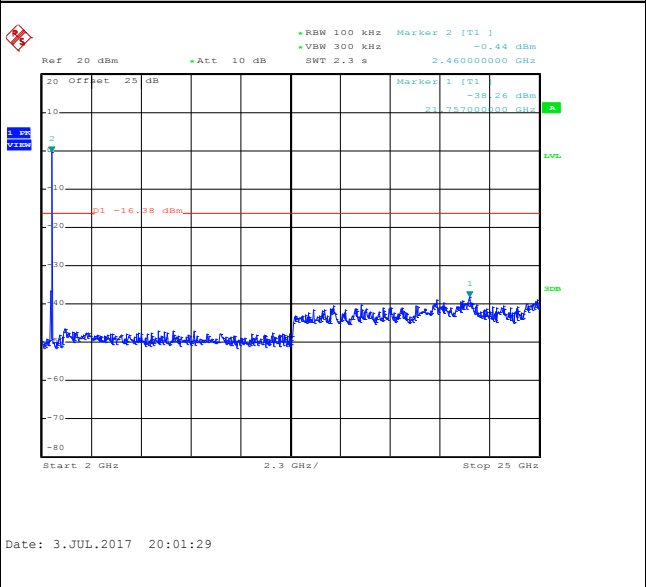



Number of TX = 1, Ant. 2 (Measured)

Number of TX :	1	Ant. :	2
Test Mode :	802.11b	Temperature :	21~25°C
Test Band :	2.4GHz Low	Relative Humidity :	51~54%
Test Channel :	01	Test Engineer :	Tommy Lee / Aking Chang

WLAN 802.11b Channel 01

100kHz PSD reference Level

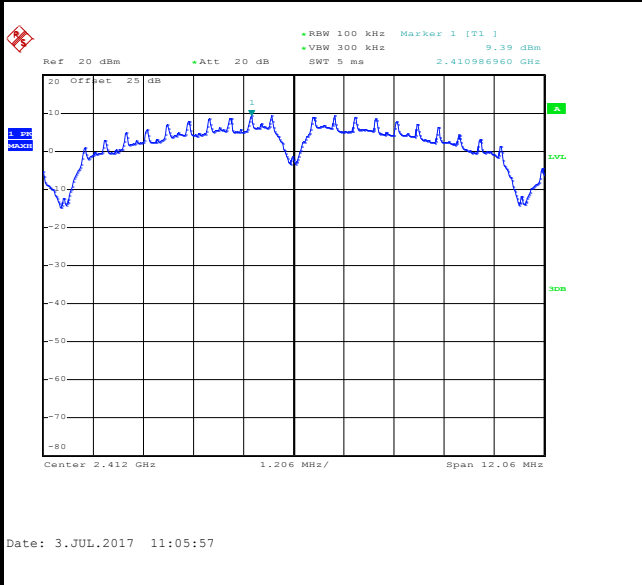

Low Channel Plot

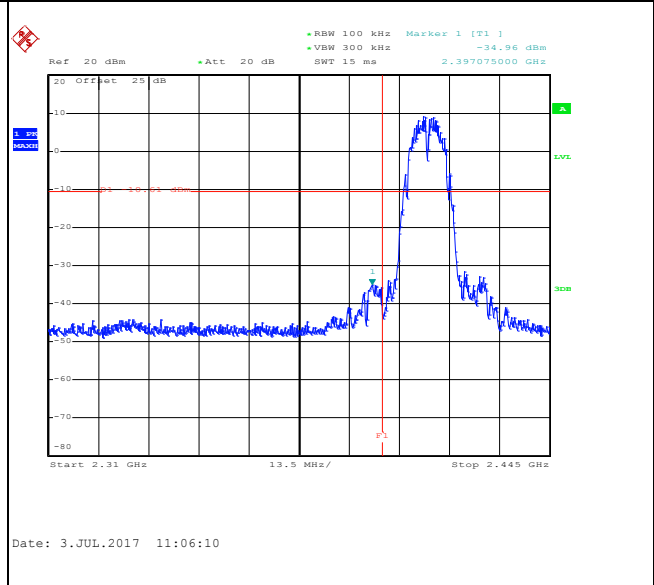

Spurious Emission 30MHz~3GHz

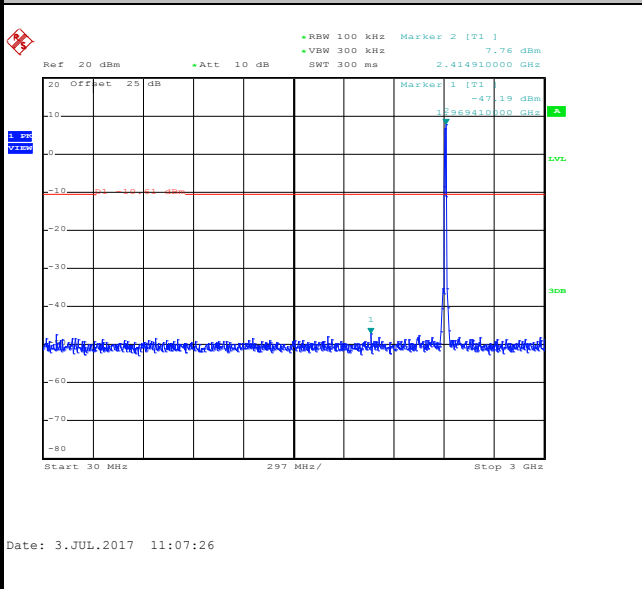

Spurious Emission 2GHz~25GHz

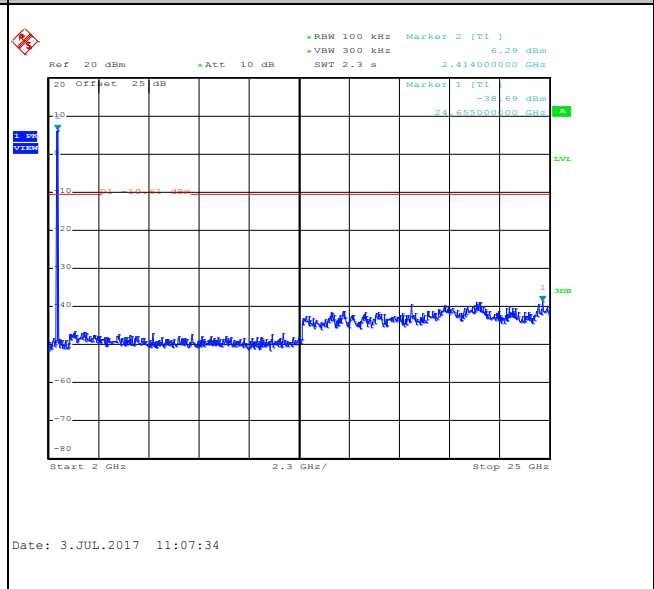



Number of TX :	1	Ant. :	2
Test Mode :	802.11b	Temperature :	21~25°C
Test Band :	2.4GHz Mid	Relative Humidity :	51~54%
Test Channel :	06	Test Engineer :	Tommy Lee / Aking Chang

WLAN 802.11b Channel 06

100kHz PSD reference Level

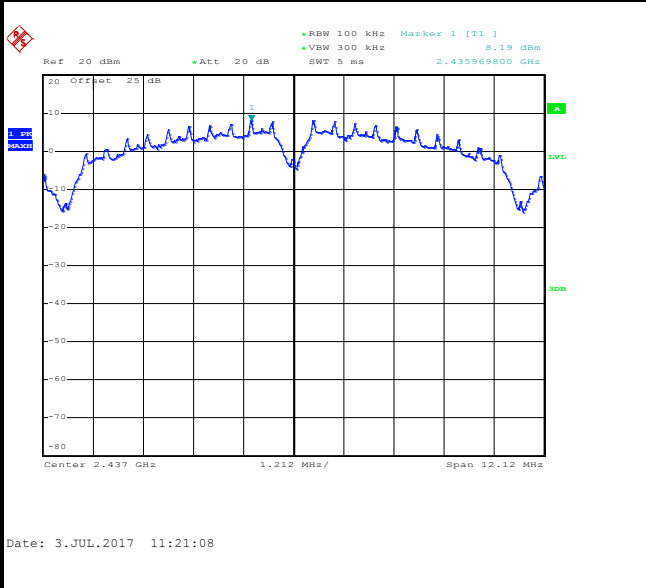

Spurious Emission 30MHz~3GHz

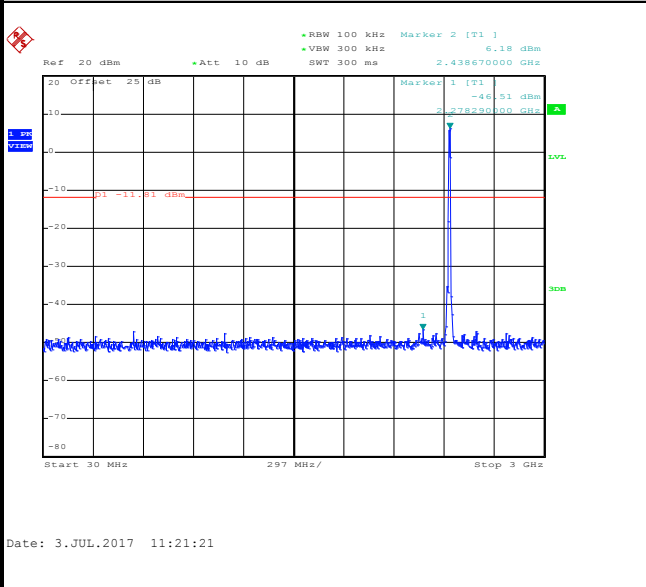

Spurious Emission 2GHz~25GHz

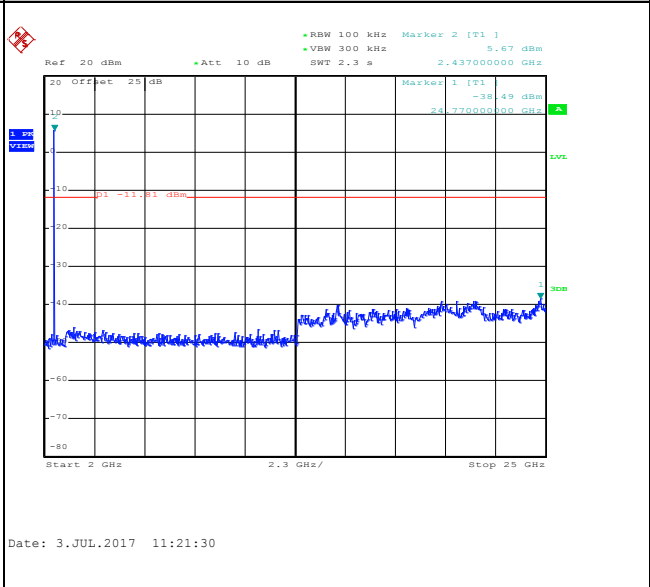



Number of TX :	1	Ant. :	2
Test Mode :	802.11b	Temperature :	21~25°C
Test Band :	2.4GHz High	Relative Humidity :	51~54%
Test Channel :	11	Test Engineer :	Tommy Lee / Aking Chang

WLAN 802.11b Channel 11

100kHz PSD reference Level

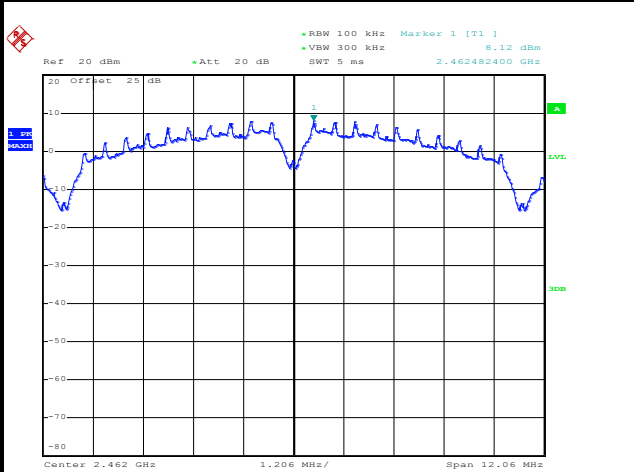

Date: 3.JUL.2017 11:31:27

High Channel Plot

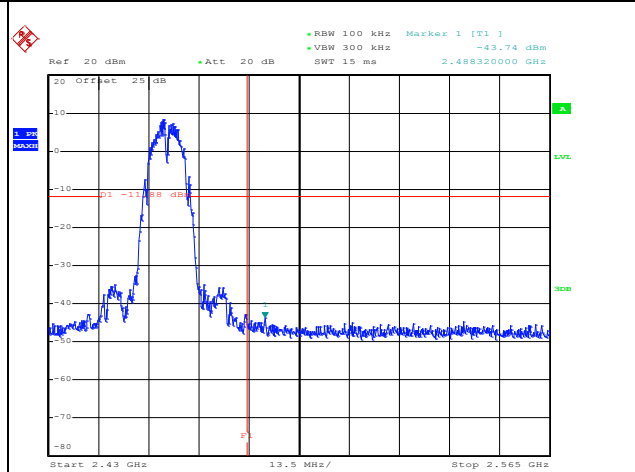

Date: 3.JUL.2017 11:32:27

Spurious Emission 30MHz~3GHz

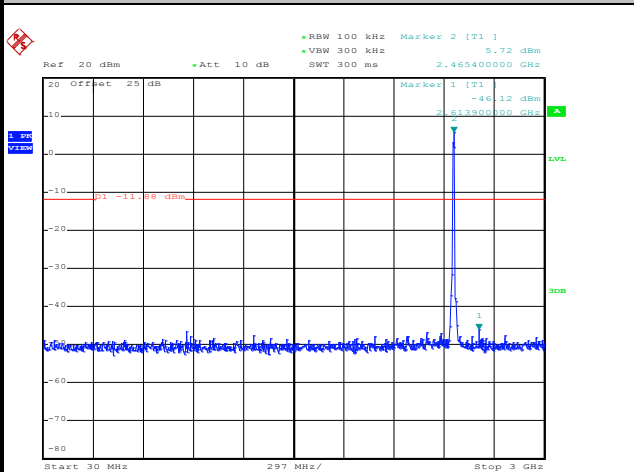

Date: 3.JUL.2017 11:39:05

Spurious Emission 2GHz~25GHz

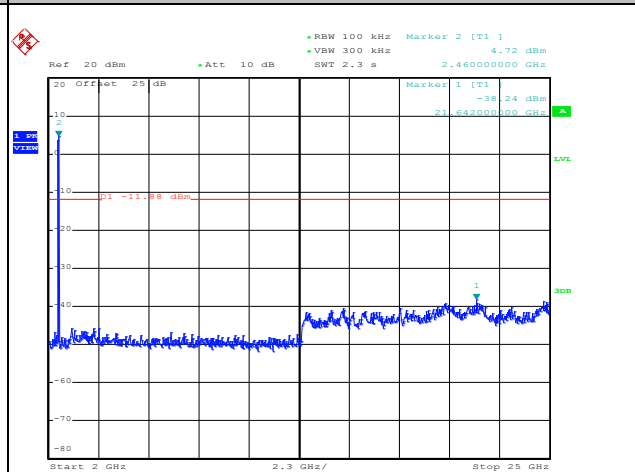

Date: 3.JUL.2017 11:39:13



Number of TX :	1	Ant. :	2
Test Mode :	802.11b	Temperature :	21~25°C
Test Band :	2.4GHz High	Relative Humidity :	51~54%
Test Channel :	12	Test Engineer :	Tommy Lee / Aking Chang

WLAN 802.11b Channel 12

100kHz PSD reference Level

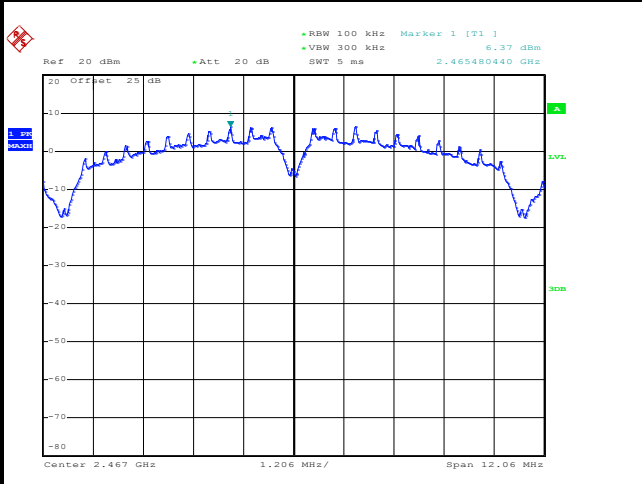

Date: 3.JUL.2017 11:43:03

High Channel Plot

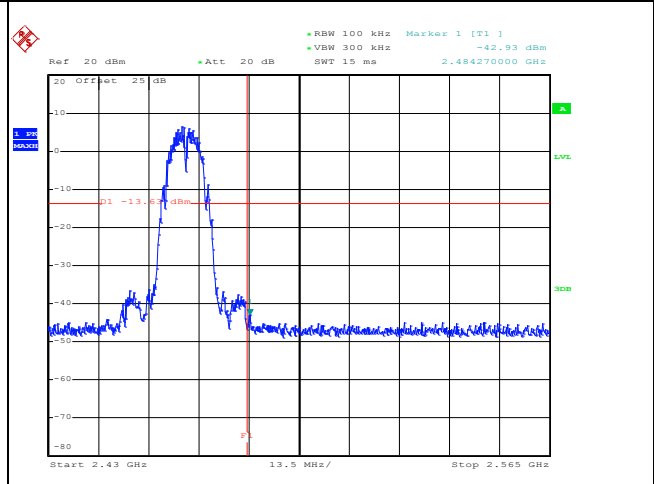

Date: 3.JUL.2017 11:53:02

Spurious Emission 30MHz~3GHz

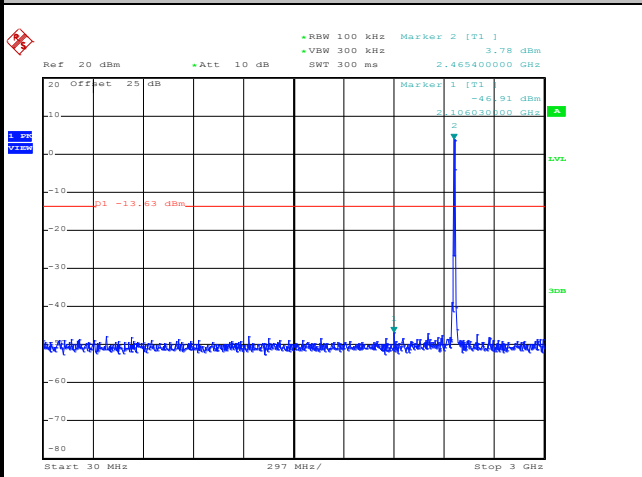

Date: 3.JUL.2017 11:43:41

Spurious Emission 2GHz~25GHz

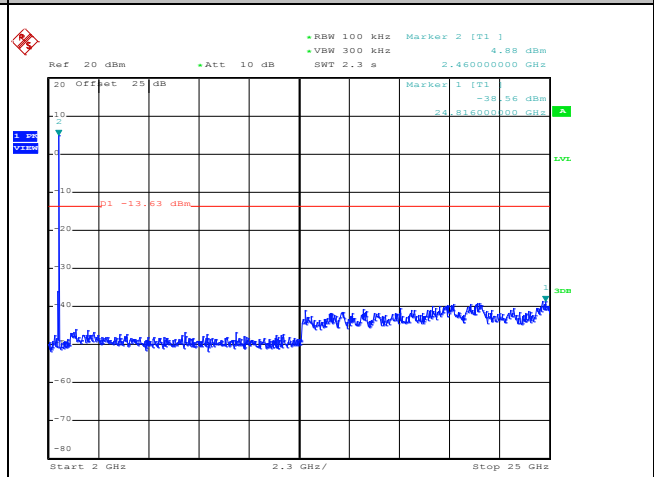

Date: 3.JUL.2017 11:43:49



Number of TX :	1	Ant. :	2
Test Mode :	802.11b	Temperature :	21~25°C
Test Band :	2.4GHz High	Relative Humidity :	51~54%
Test Channel :	13	Test Engineer :	Tommy Lee / Aking Chang

WLAN 802.11b Channel 13

100kHz PSD reference Level

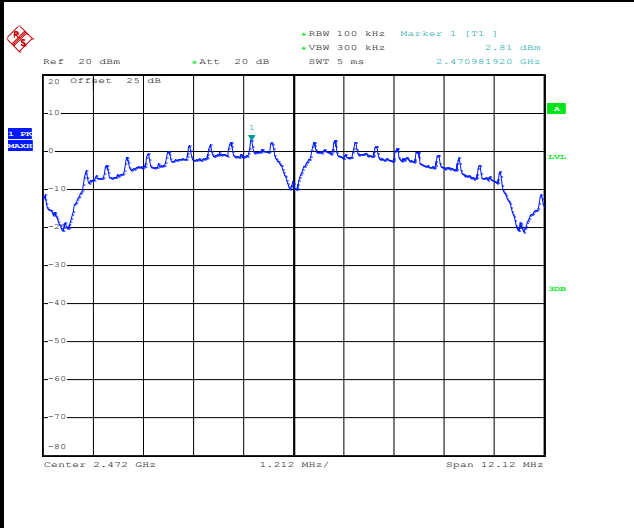

High Channel Plot

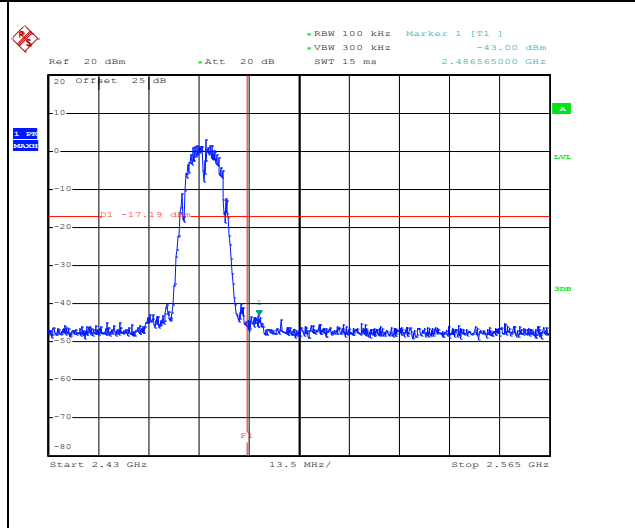

Spurious Emission 30MHz~3GHz

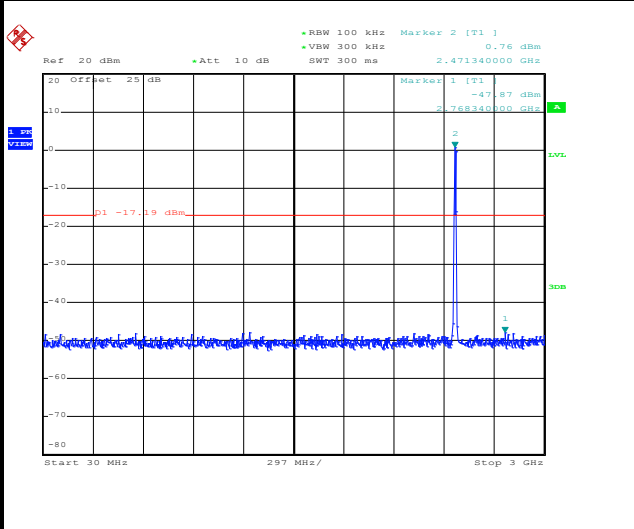

Spurious Emission 2GHz~25GHz

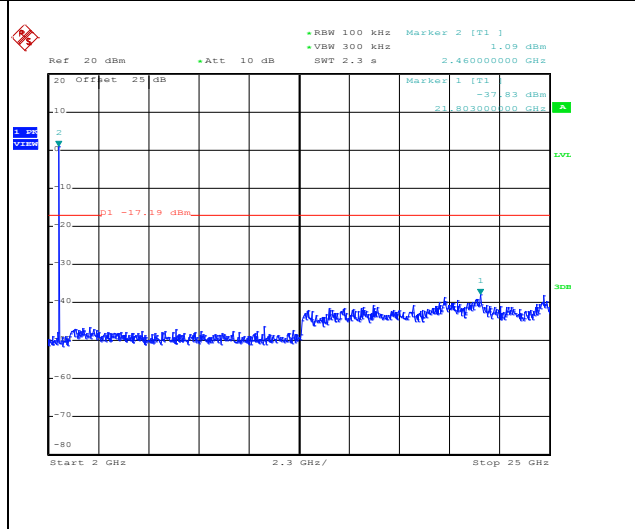



Number of TX :	1	Ant. :	2
Test Mode :	802.11g	Temperature :	21~25°C
Test Band :	2.4GHz Low	Relative Humidity :	51~54%
Test Channel :	01	Test Engineer :	Tommy Lee / Aking Chang

WLAN 802.11g Channel 01

100kHz PSD reference Level

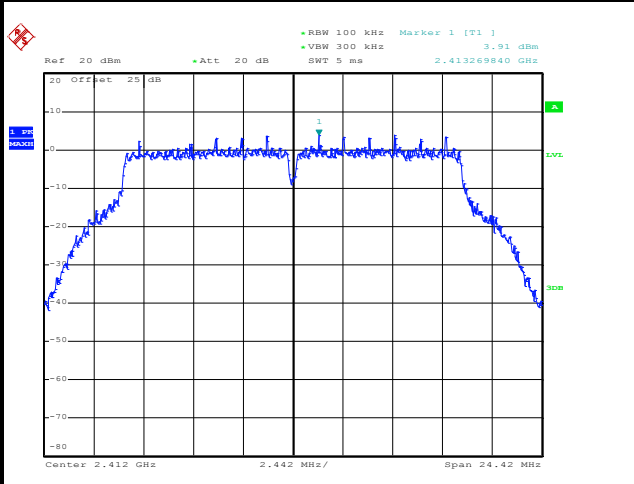

Date: 3.JUL.2017 18:44:32

Low Channel Plot

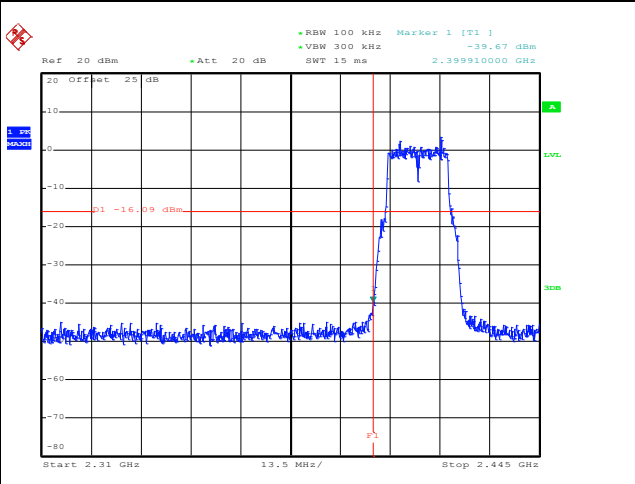

Date: 3.JUL.2017 18:44:48

Spurious Emission 30MHz~3GHz

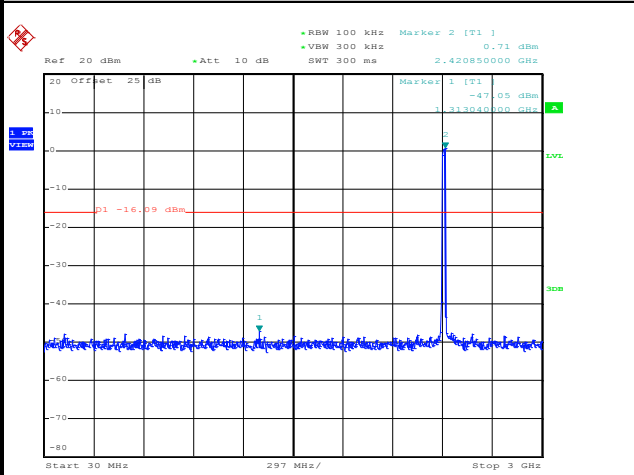

Date: 3.JUL.2017 18:45:00

Spurious Emission 2GHz~25GHz

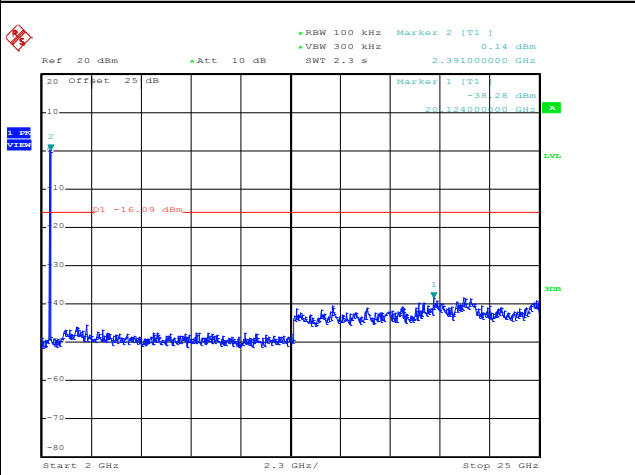

Date: 3.JUL.2017 18:45:08



Number of TX :	1	Ant. :	2
Test Mode :	802.11g	Temperature :	21~25°C
Test Band :	2.4GHz Mid	Relative Humidity :	51~54%
Test Channel :	06	Test Engineer :	Tommy Lee / Aking Chang

WLAN 802.11g Channel 06

100kHz PSD reference Level

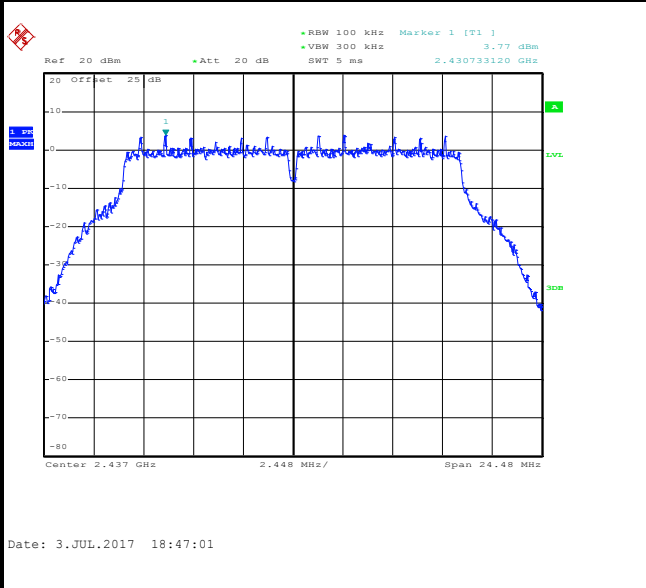

Spurious Emission 30MHz~3GHz

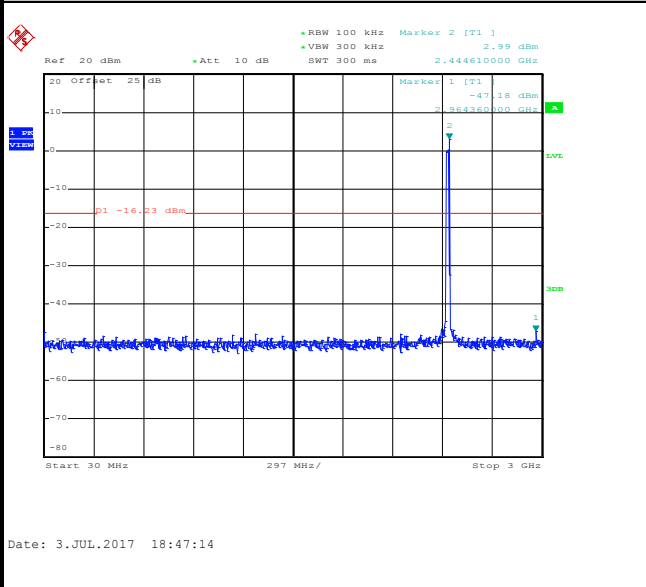

Spurious Emission 2GHz~25GHz

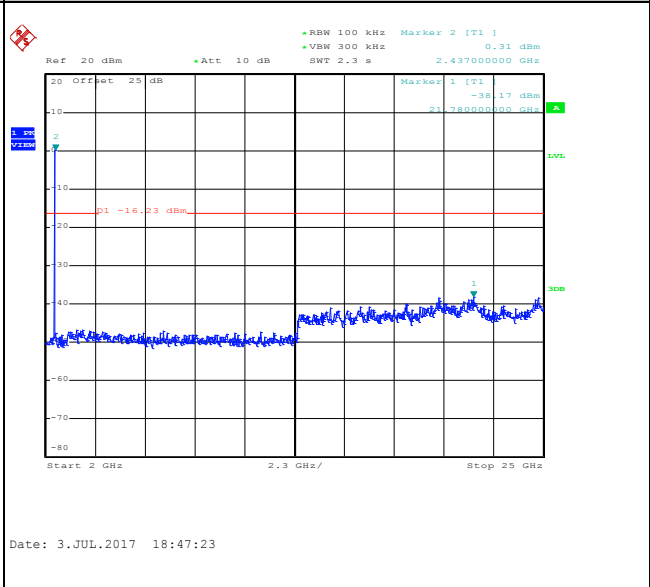



Number of TX :	1	Ant. :	2
Test Mode :	802.11g	Temperature :	21~25°C
Test Band :	2.4GHz High	Relative Humidity :	51~54%
Test Channel :	11	Test Engineer :	Tommy Lee / Aking Chang

WLAN 802.11g Channel 11

100kHz PSD reference Level

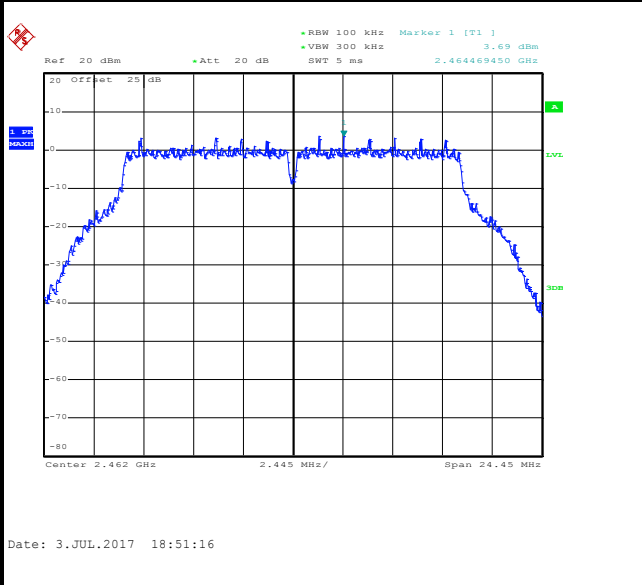

High Channel Plot

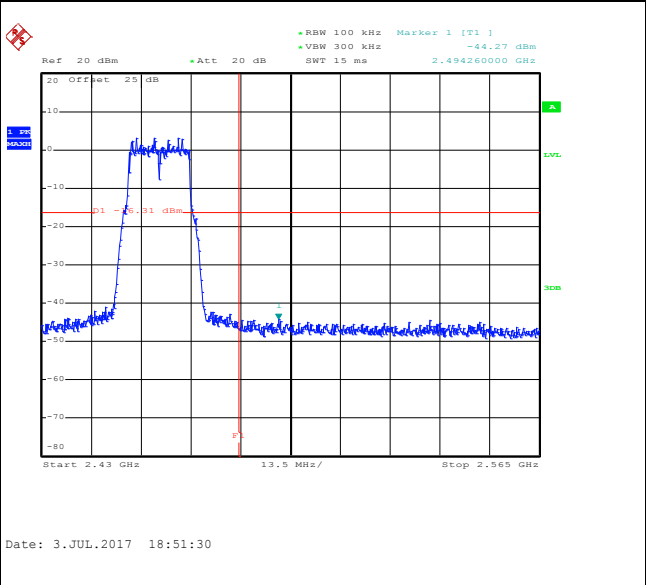

Spurious Emission 30MHz~3GHz

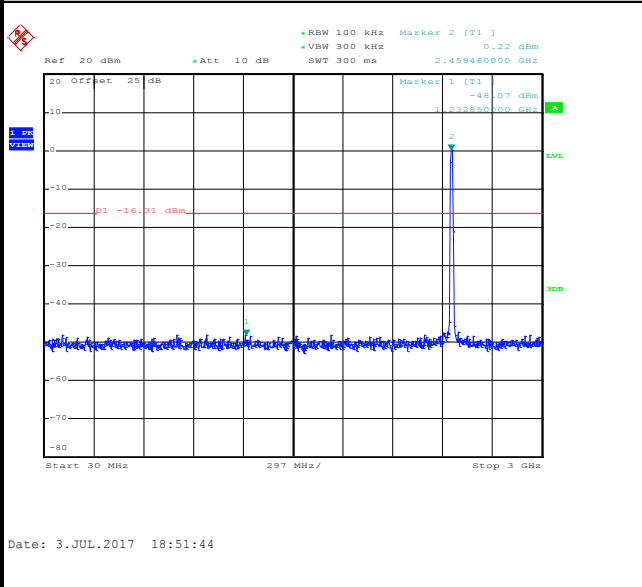

Spurious Emission 2GHz~25GHz

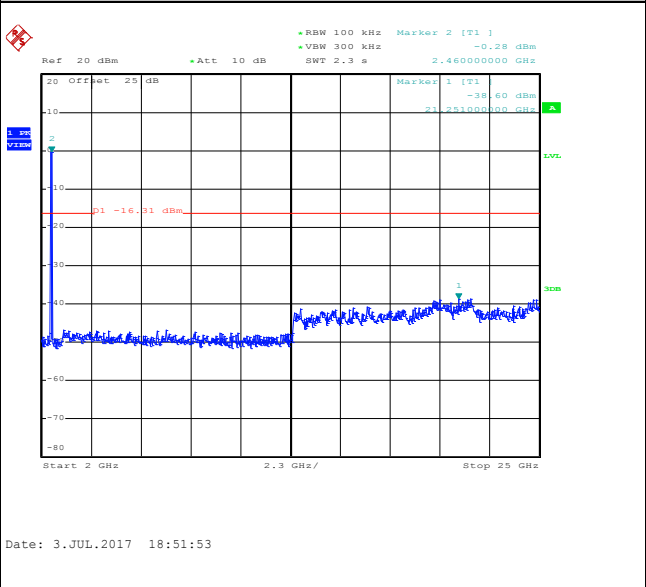



Number of TX :	1	Ant. :	2
Test Mode :	802.11g	Temperature :	21~25°C
Test Band :	2.4GHz High	Relative Humidity :	51~54%
Test Channel :	12	Test Engineer :	Tommy Lee / Aking Chang

WLAN 802.11g Channel 12

100kHz PSD reference Level

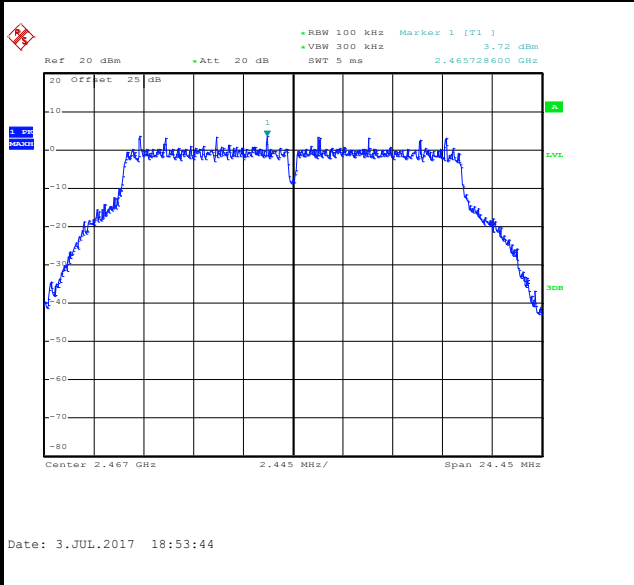

High Channel Plot

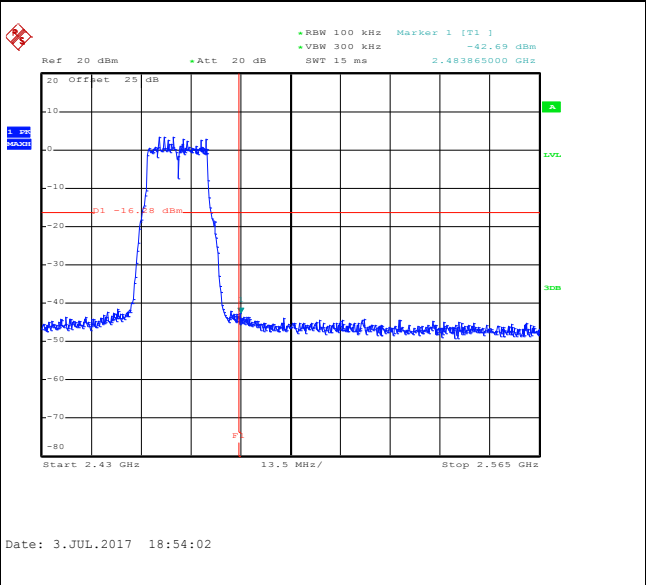

Spurious Emission 30MHz~3GHz

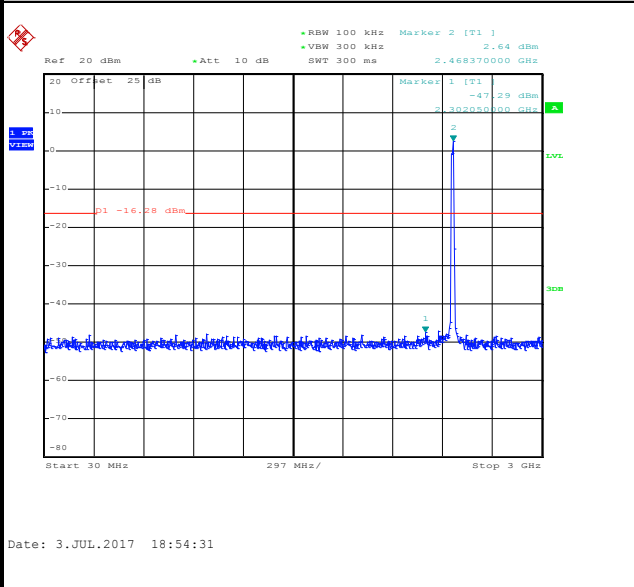

Spurious Emission 2GHz~25GHz

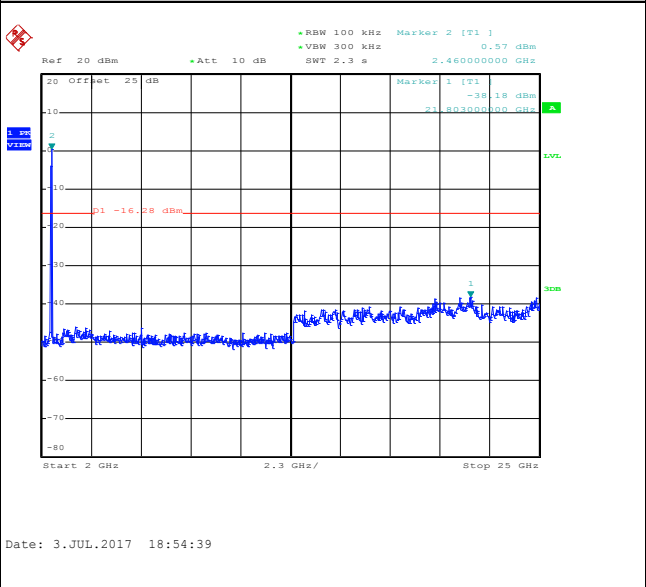



Number of TX :	1	Ant. :	2
Test Mode :	802.11g	Temperature :	21~25°C
Test Band :	2.4GHz High	Relative Humidity :	51~54%
Test Channel :	13	Test Engineer :	Tommy Lee / Aking Chang

WLAN 802.11g Channel 13

100kHz PSD reference Level

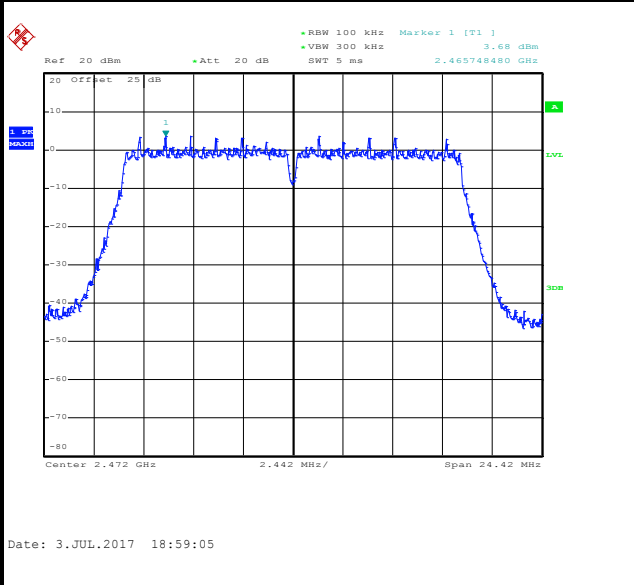

High Channel Plot

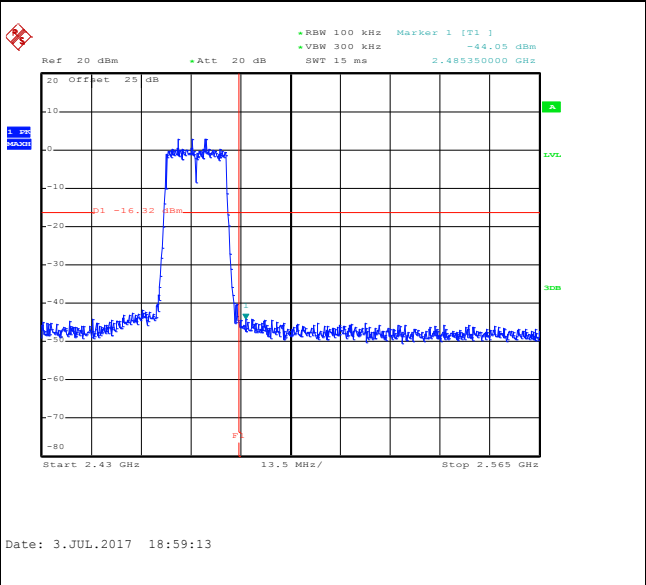

Spurious Emission 30MHz~3GHz

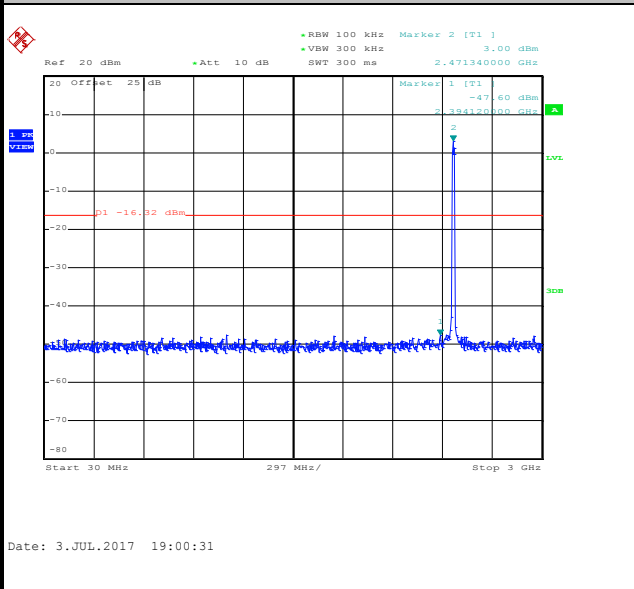

Spurious Emission 2GHz~25GHz

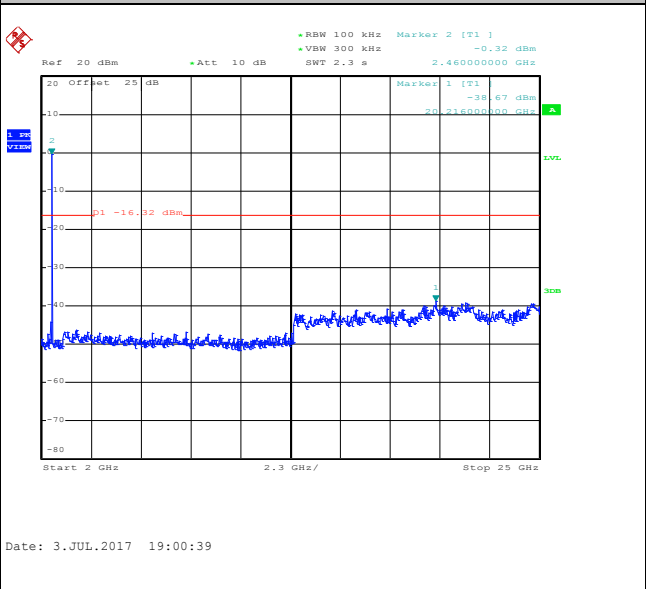



Number of TX :	1	Ant. :	2
Test Mode :	802.11n HT20	Temperature :	21~25°C
Test Band :	2.4GHz Low	Relative Humidity :	51~54%
Test Channel :	01	Test Engineer :	Tommy Lee / Aking Chang

WLAN 802.11n HT20 Channel 01

100kHz PSD reference Level

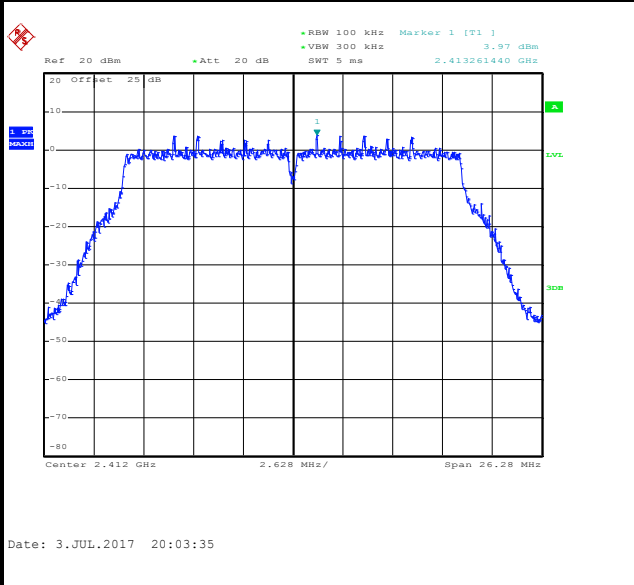

Low Channel Plot

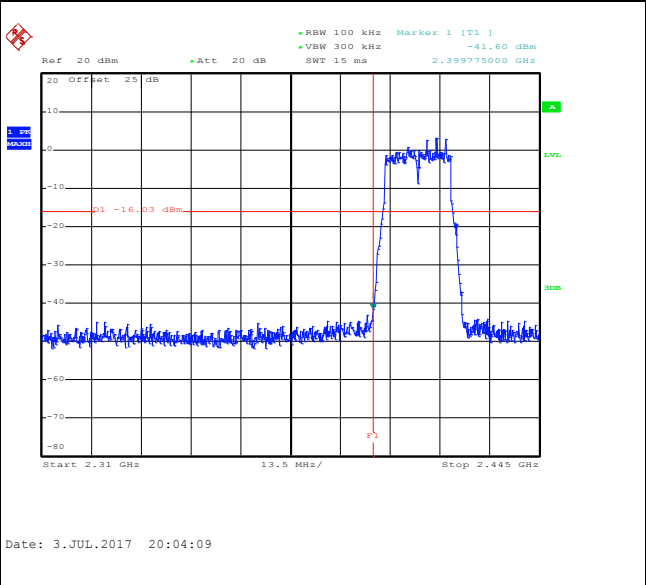

Spurious Emission 30MHz~3GHz

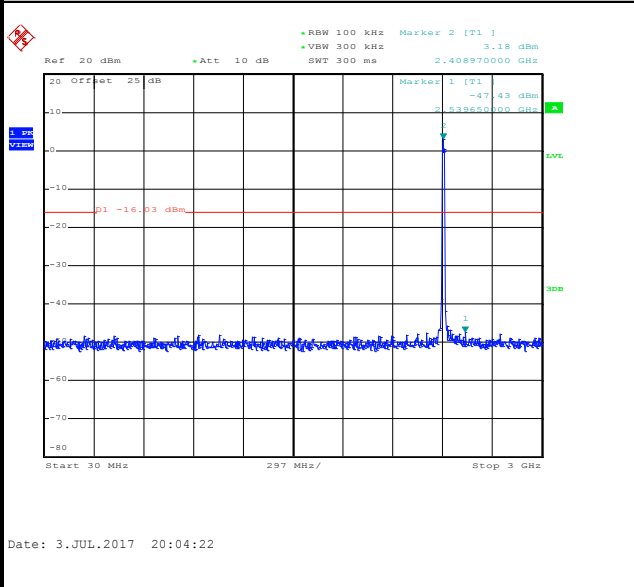

Spurious Emission 2GHz~25GHz

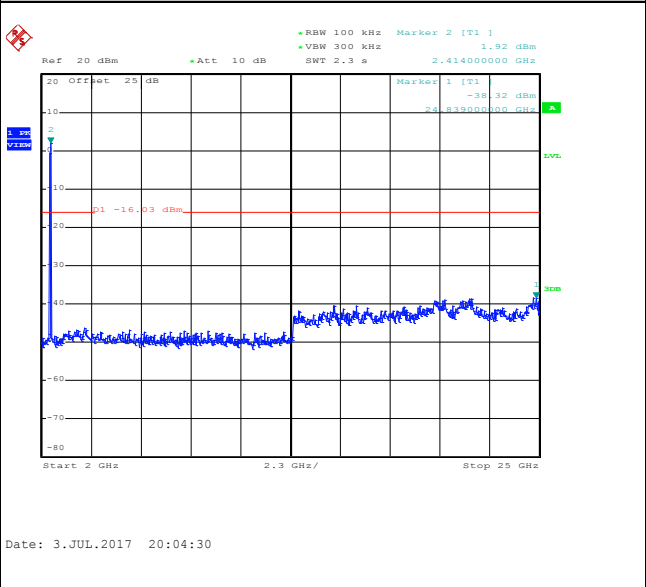



Number of TX :	1	Ant. :	2
Test Mode :	802.11n HT20	Temperature :	21~25°C
Test Band :	2.4GHz Mid	Relative Humidity :	51~54%
Test Channel :	06	Test Engineer :	Tommy Lee / Aking Chang

WLAN 802.11n HT20 Channel 06

100kHz PSD reference Level

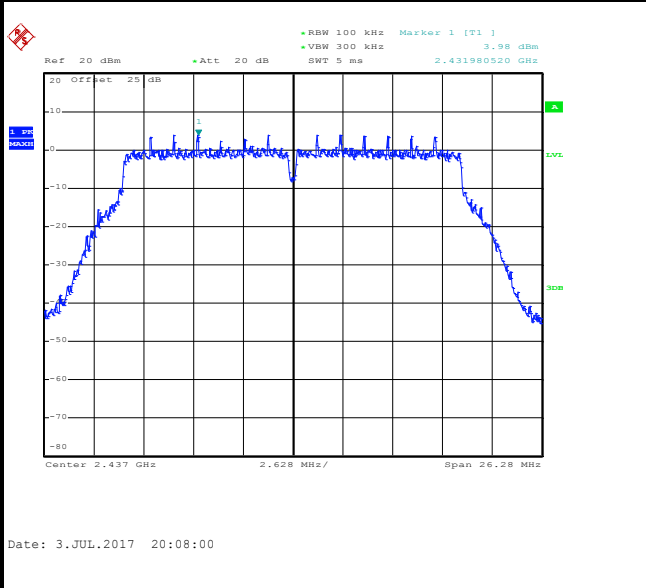

Spurious Emission 30MHz~3GHz

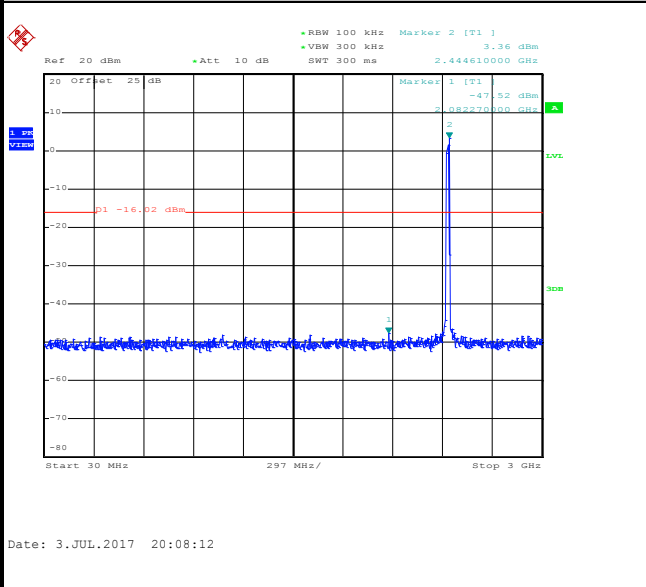

Spurious Emission 2GHz~25GHz

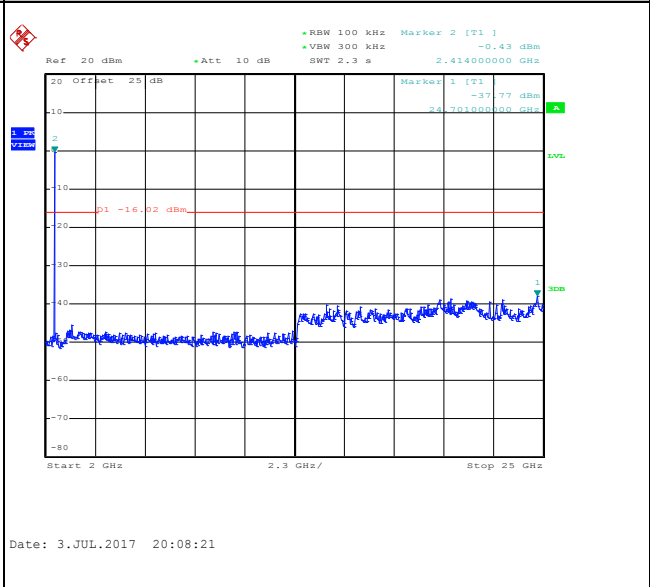



Number of TX :	1	Ant. :	2
Test Mode :	802.11n HT20	Temperature :	21~25°C
Test Band :	2.4GHz High	Relative Humidity :	51~54%
Test Channel :	11	Test Engineer :	Tommy Lee / Aking Chang

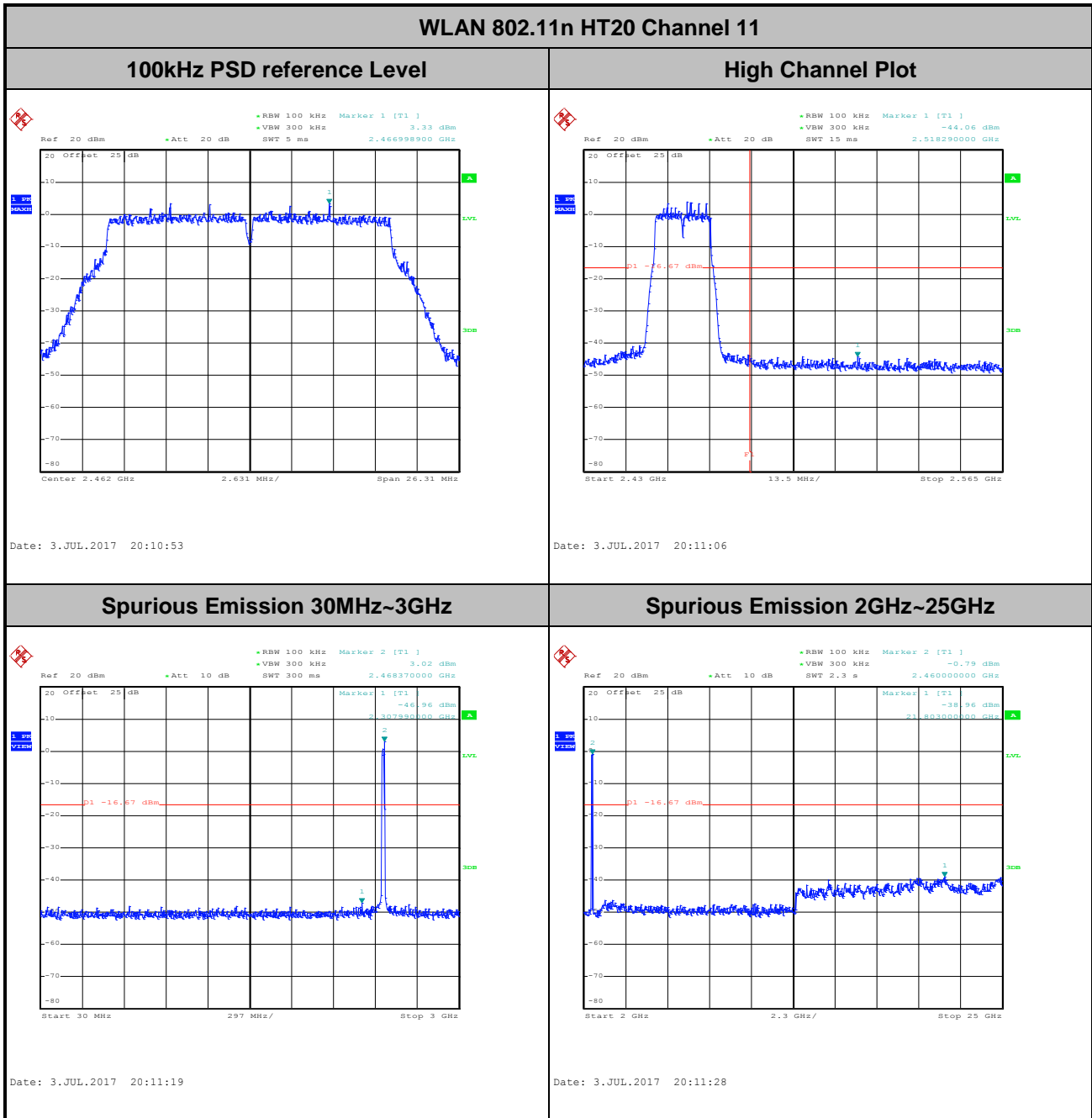



Number of TX :	1	Ant. :	2
Test Mode :	802.11n HT20	Temperature :	21~25°C
Test Band :	2.4GHz High	Relative Humidity :	51~54%
Test Channel :	12	Test Engineer :	Tommy Lee / Aking Chang

WLAN 802.11n HT20 Channel 12

100kHz PSD reference Level

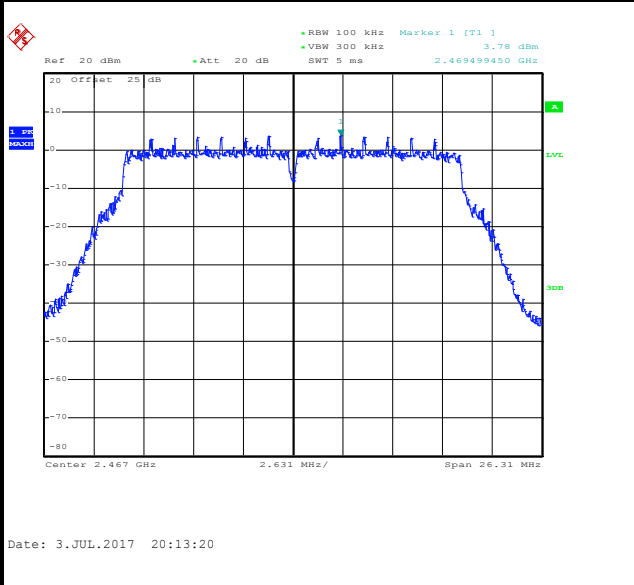

High Channel Plot

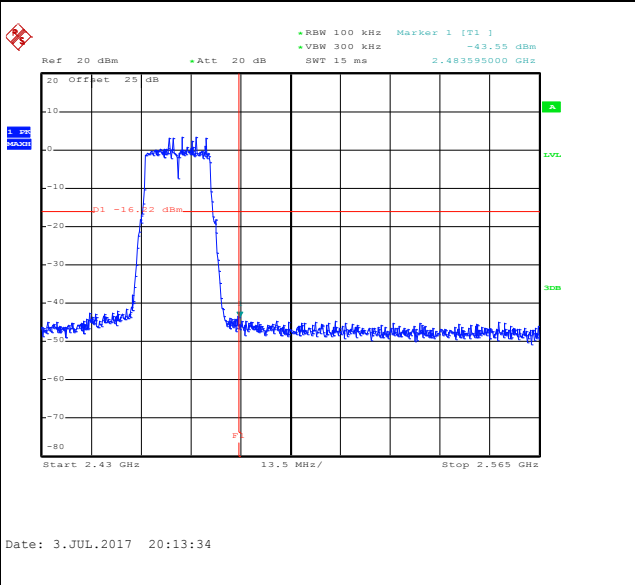

Spurious Emission 30MHz~3GHz

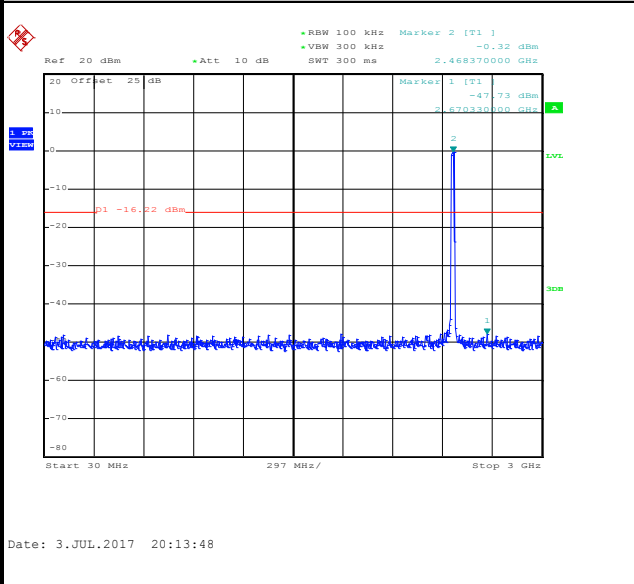

Spurious Emission 2GHz~25GHz

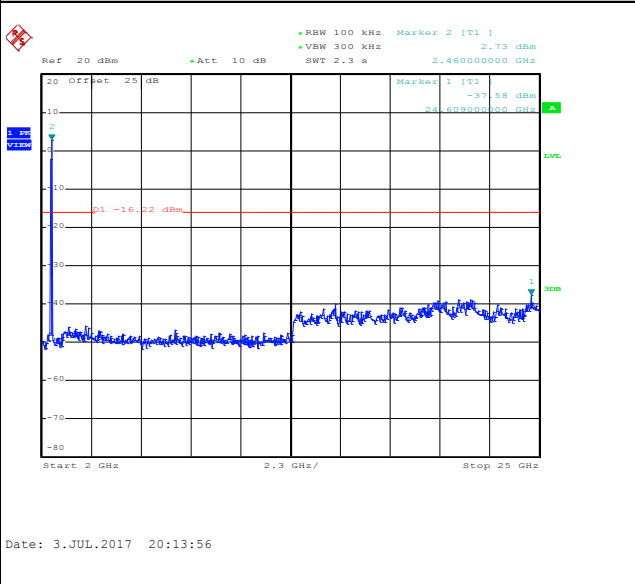



Number of TX :	1	Ant. :	2
Test Mode :	802.11n HT20	Temperature :	21~25°C
Test Band :	2.4GHz High	Relative Humidity :	51~54%
Test Channel :	13	Test Engineer :	Tommy Lee / Aking Chang

WLAN 802.11n HT20 Channel 13

100kHz PSD reference Level

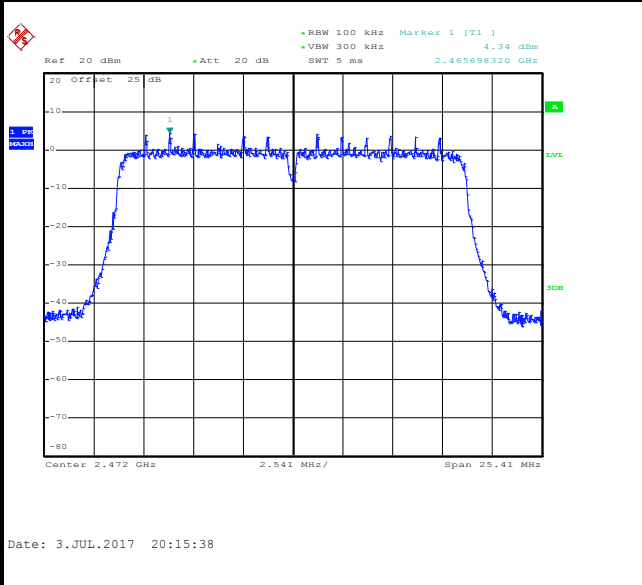

High Channel Plot

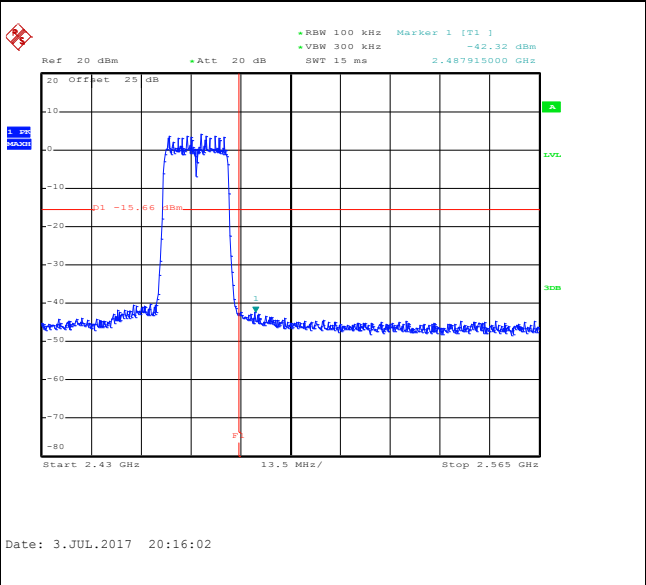

Spurious Emission 30MHz~3GHz

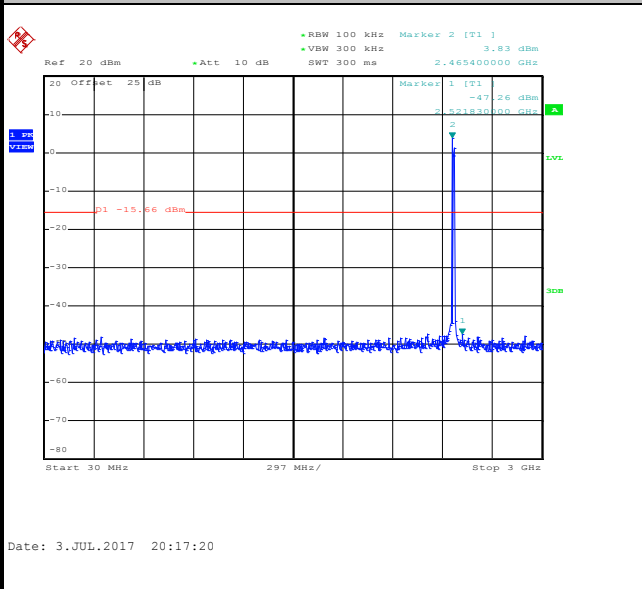

Spurious Emission 2GHz~25GHz

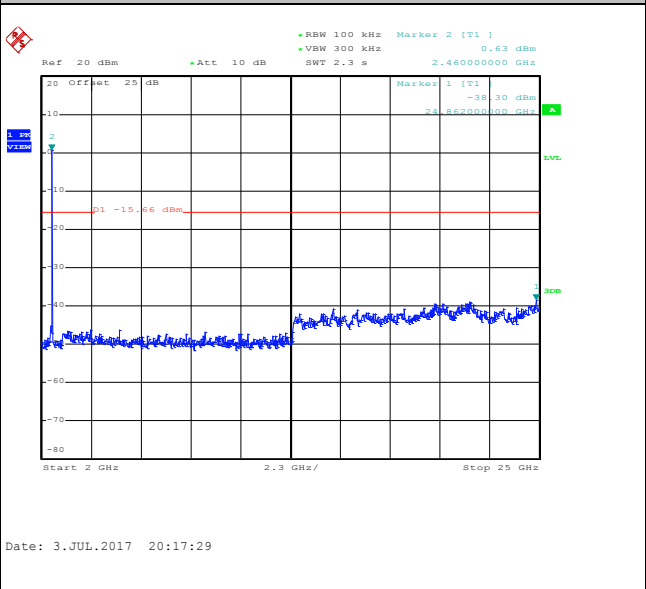



Number of TX = 2, Ant. 1 (Measured)

Number of TX :	2	Ant. :	1
Test Mode :	802.11g	Temperature :	21~25°C
Test Band :	2.4GHz Low	Relative Humidity :	51~54%
Test Channel :	01	Test Engineer :	Tommy Lee / Aking Chang

WLAN 802.11g Channel 01

100kHz PSD reference Level

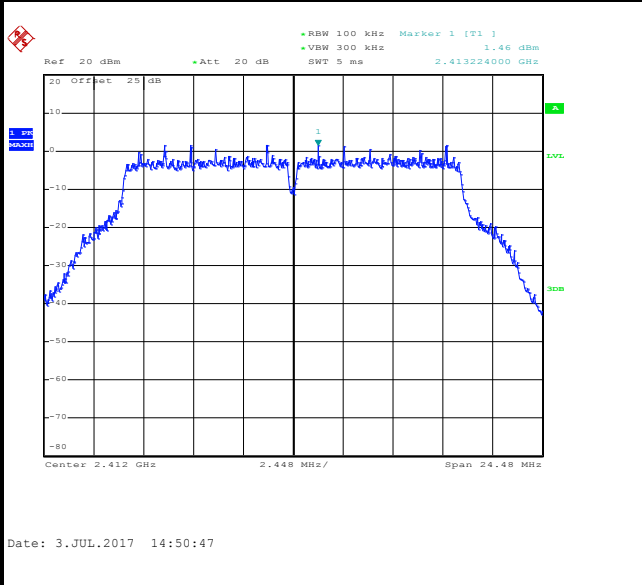

Low Channel Plot

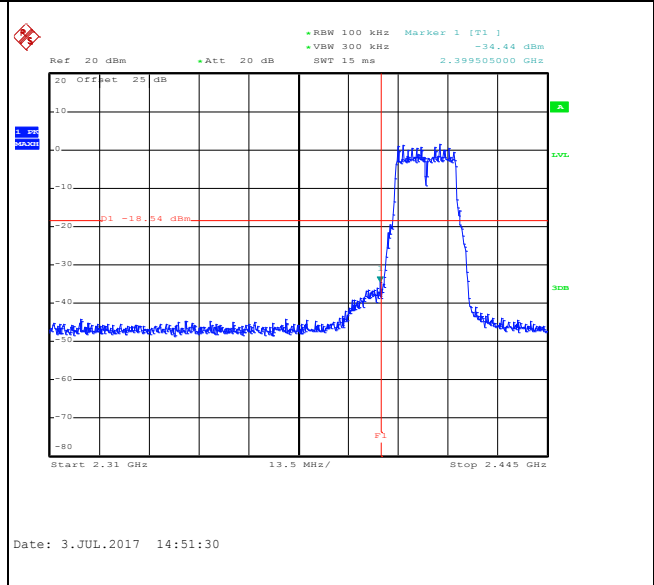

Spurious Emission 30MHz~3GHz

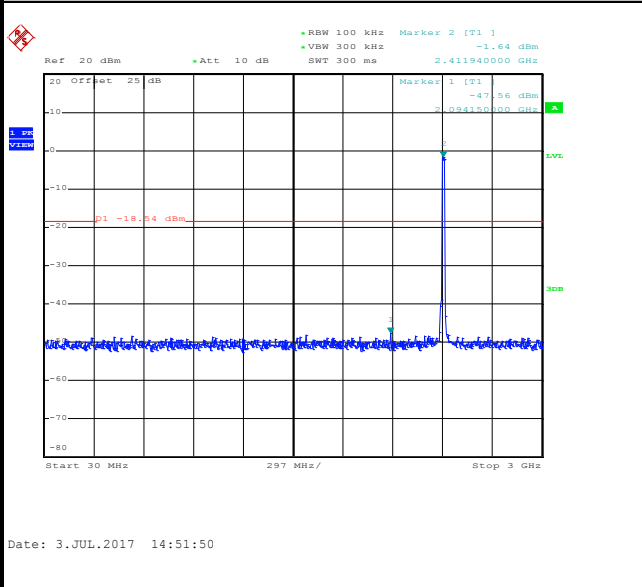

Spurious Emission 2GHz~25GHz

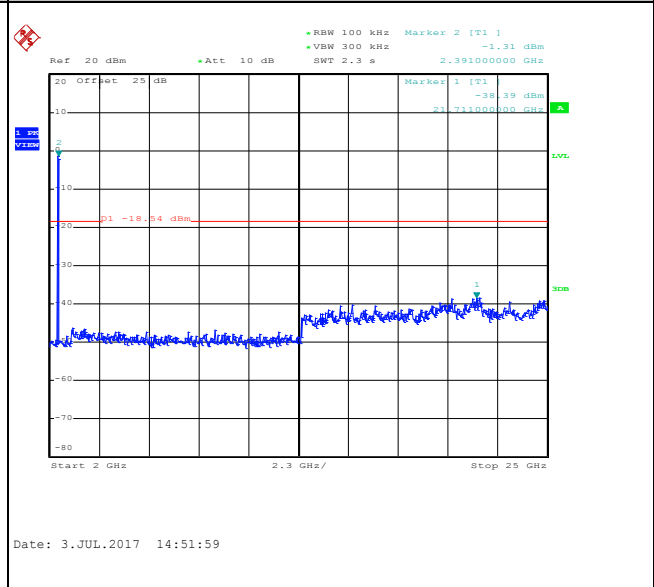



Number of TX :	2	Ant. :	1
Test Mode :	802.11g	Temperature :	21~25°C
Test Band :	2.4GHz Mid	Relative Humidity :	51~54%
Test Channel :	06	Test Engineer :	Tommy Lee / Aking Chang

WLAN 802.11g Channel 06

100kHz PSD reference Level

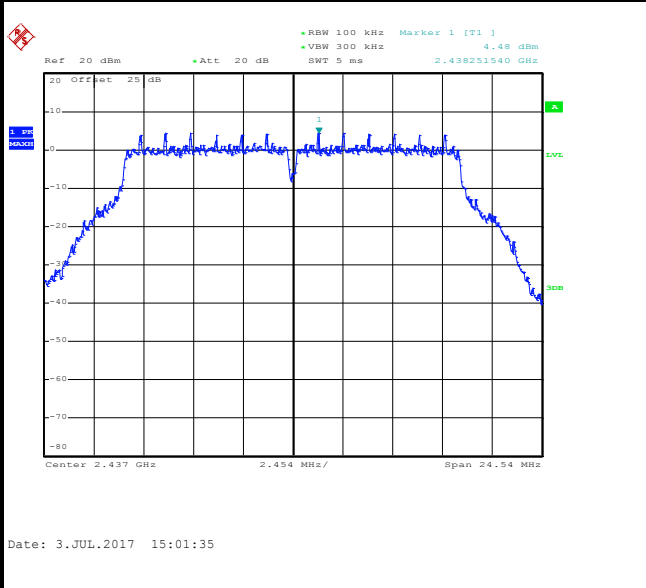

Spurious Emission 30MHz~3GHz

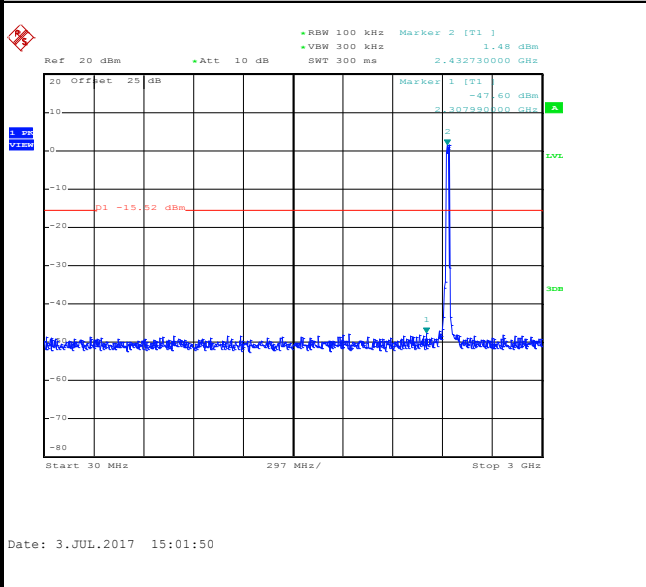

Spurious Emission 2GHz~25GHz

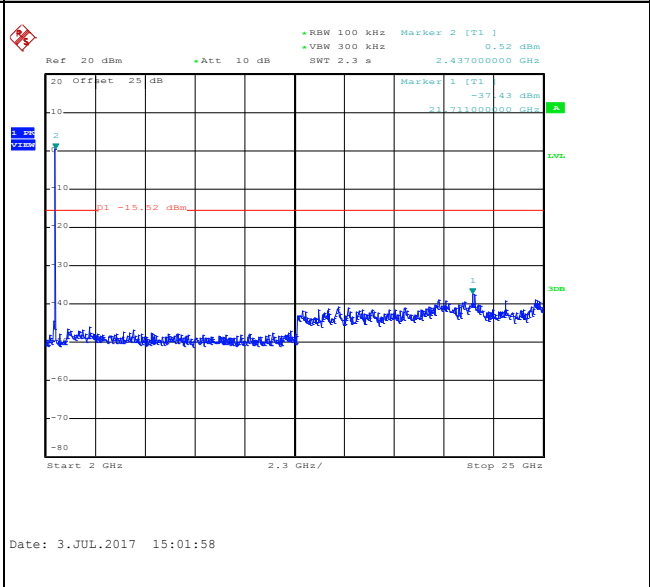



Number of TX :	2	Ant. :	1
Test Mode :	802.11g	Temperature :	21~25°C
Test Band :	2.4GHz High	Relative Humidity :	51~54%
Test Channel :	11	Test Engineer :	Tommy Lee / Aking Chang

WLAN 802.11g Channel 11

100kHz PSD reference Level

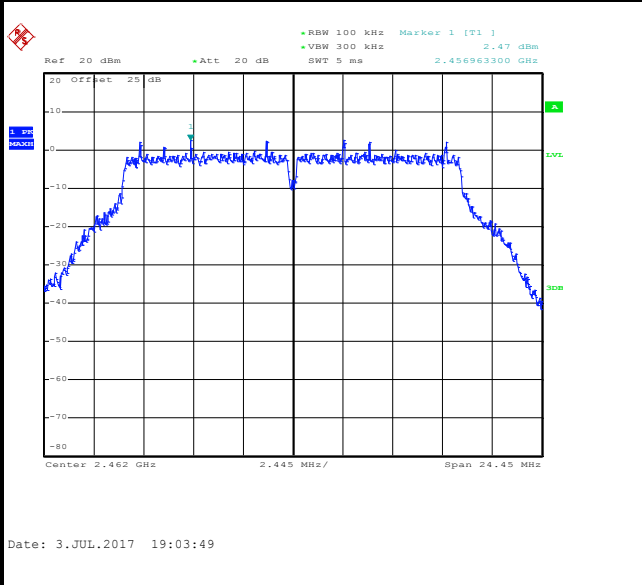

High Channel Plot

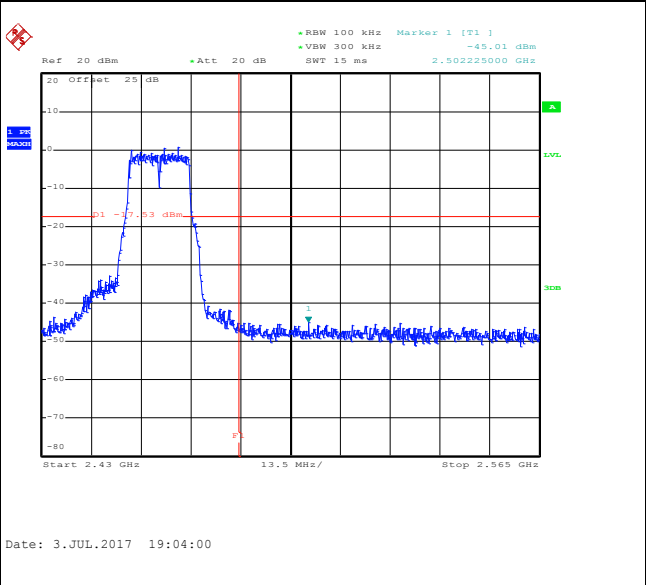

Spurious Emission 30MHz~3GHz

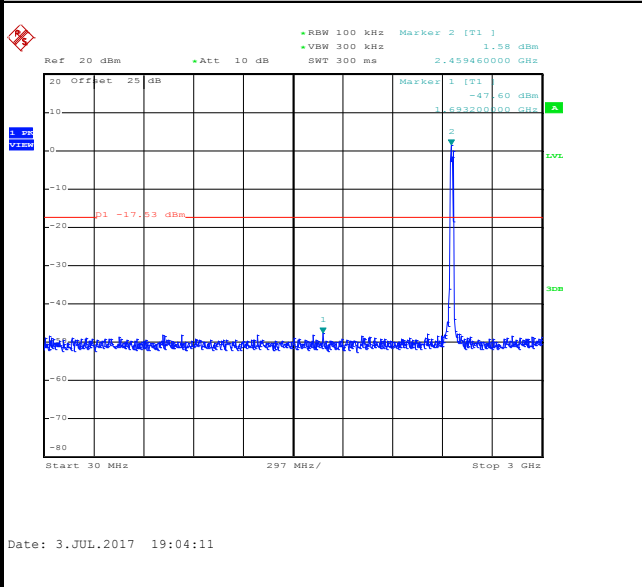

Spurious Emission 2GHz~25GHz

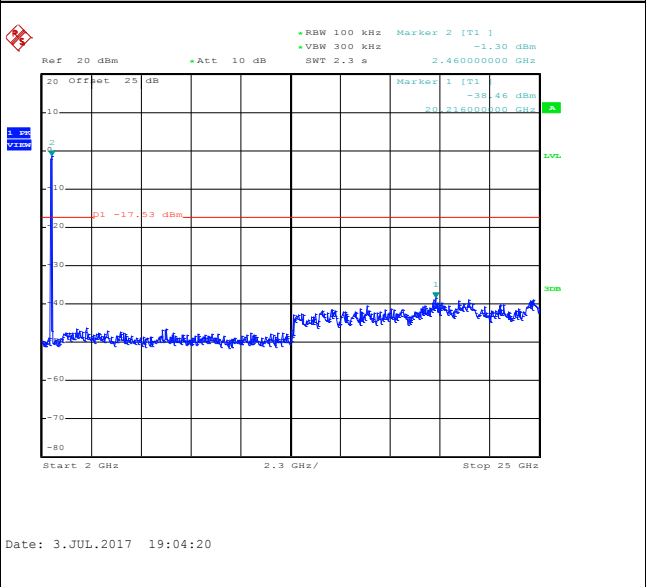



Number of TX :	2	Ant. :	1
Test Mode :	802.11g	Temperature :	21~25°C
Test Band :	2.4GHz High	Relative Humidity :	51~54%
Test Channel :	12	Test Engineer :	Tommy Lee / Aking Chang

WLAN 802.11g Channel 12

100kHz PSD reference Level

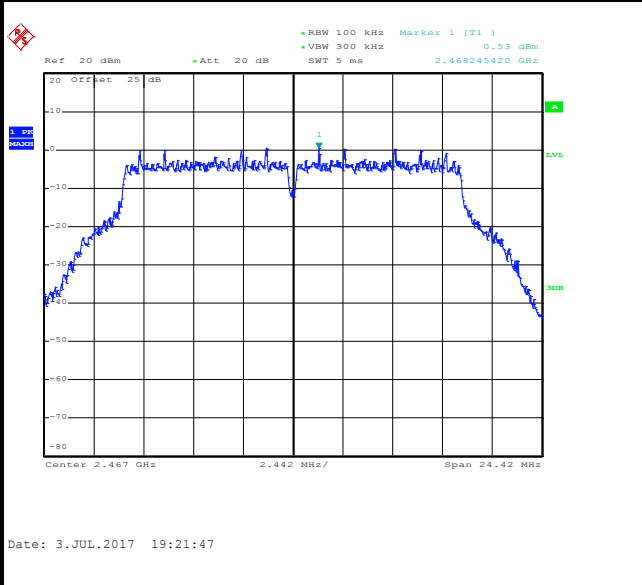

High Channel Plot

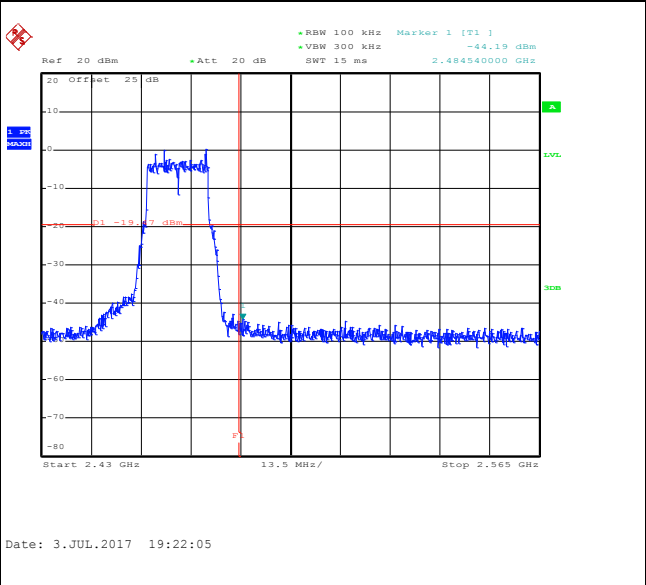

Spurious Emission 30MHz~3GHz

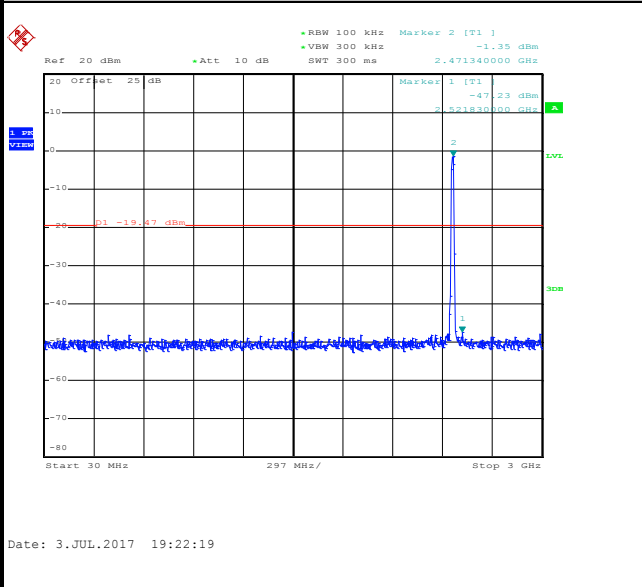

Spurious Emission 2GHz~25GHz

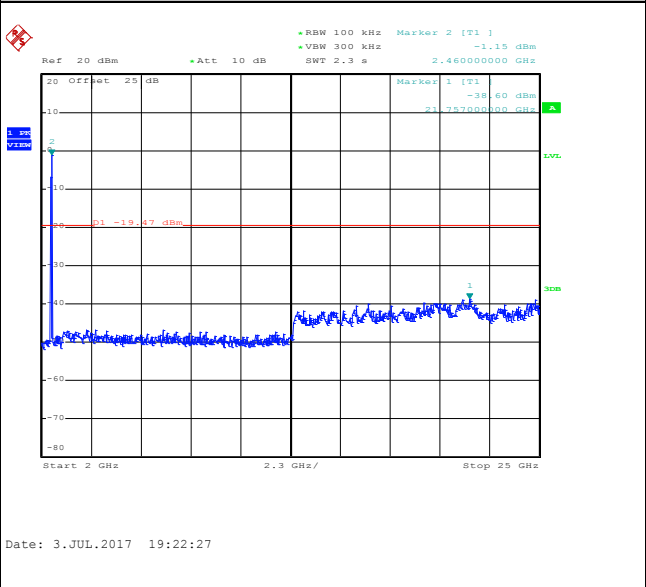



Number of TX :	2	Ant. :	1
Test Mode :	802.11g	Temperature :	21~25°C
Test Band :	2.4GHz High	Relative Humidity :	51~54%
Test Channel :	13	Test Engineer :	Tommy Lee / Aking Chang

WLAN 802.11g Channel 13

100kHz PSD reference Level

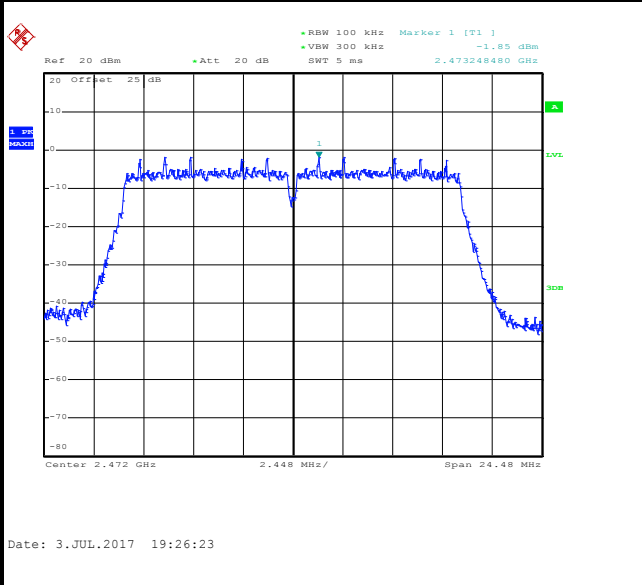

High Channel Plot

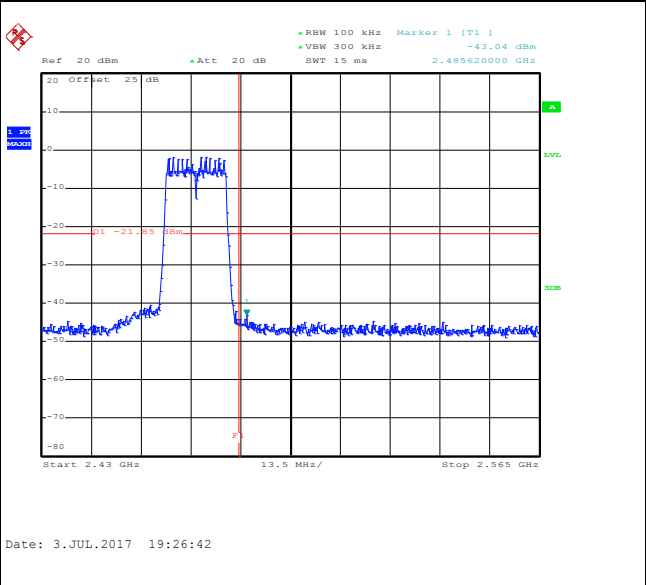

Spurious Emission 30MHz~3GHz

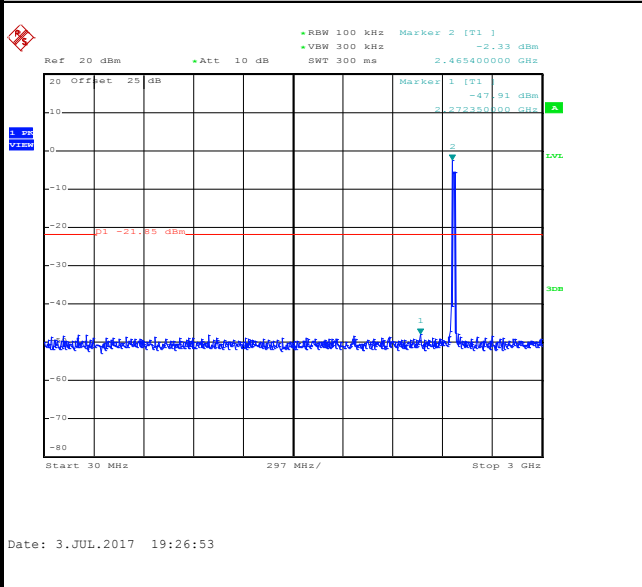

Spurious Emission 2GHz~25GHz

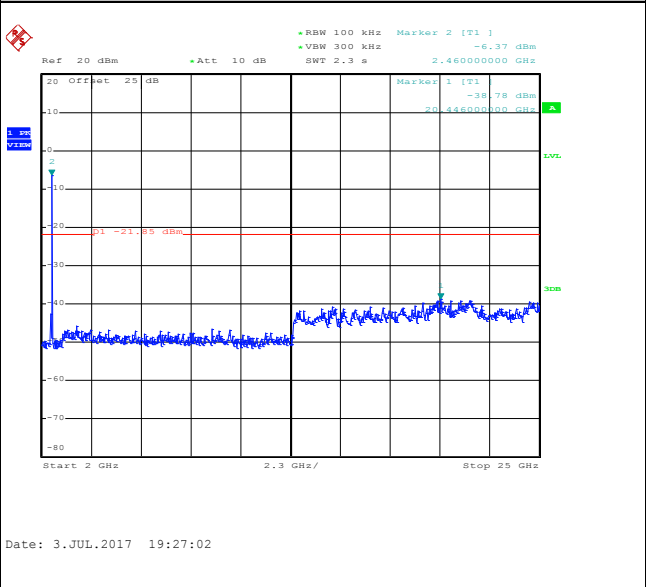



Number of TX :	2	Ant. :	1
Test Mode :	802.11n HT20	Temperature :	21~25°C
Test Band :	2.4GHz Low	Relative Humidity :	51~54%
Test Channel :	01	Test Engineer :	Tommy Lee / Aking Chang

WLAN 802.11n HT20 Channel 01

100kHz PSD reference Level



Low Channel Plot

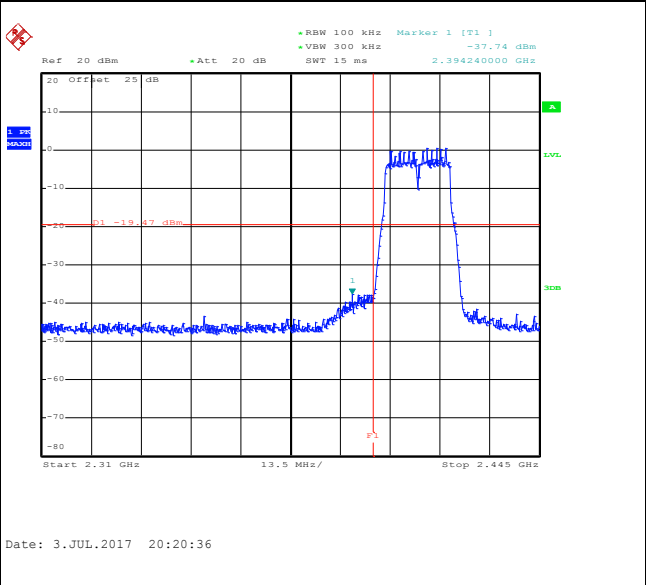

Spurious Emission 30MHz~3GHz

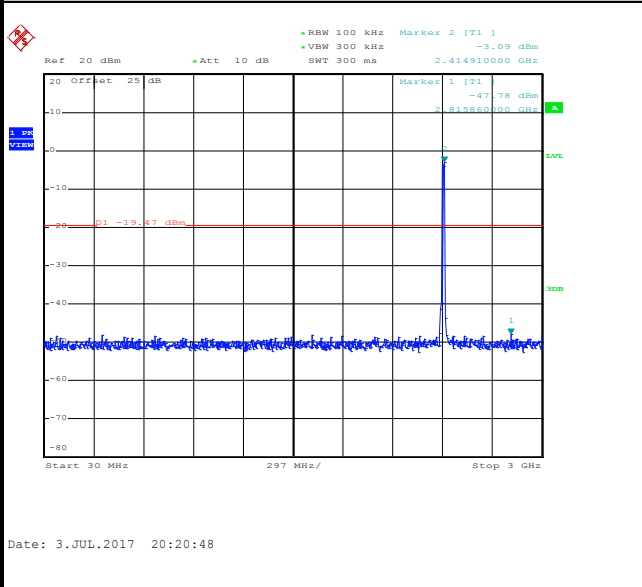

Spurious Emission 2GHz~25GHz

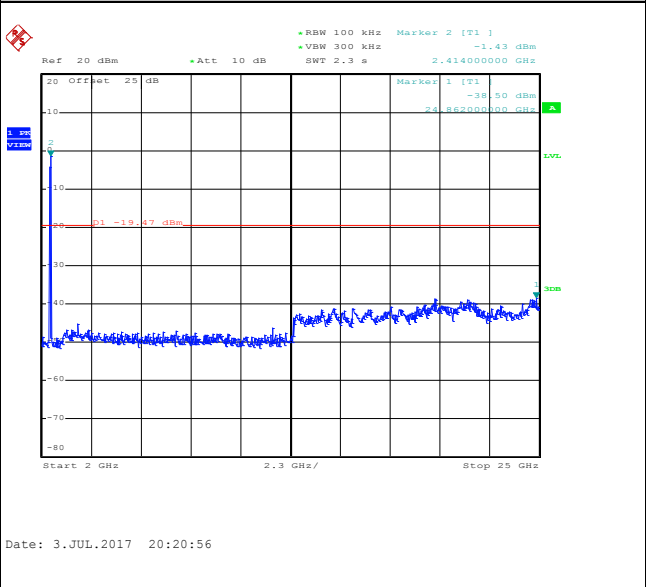



Number of TX :	2	Ant. :	1
Test Mode :	802.11n HT20	Temperature :	21~25°C
Test Band :	2.4GHz Mid	Relative Humidity :	51~54%
Test Channel :	06	Test Engineer :	Tommy Lee / Aking Chang

WLAN 802.11n HT20 Channel 06

100kHz PSD reference Level

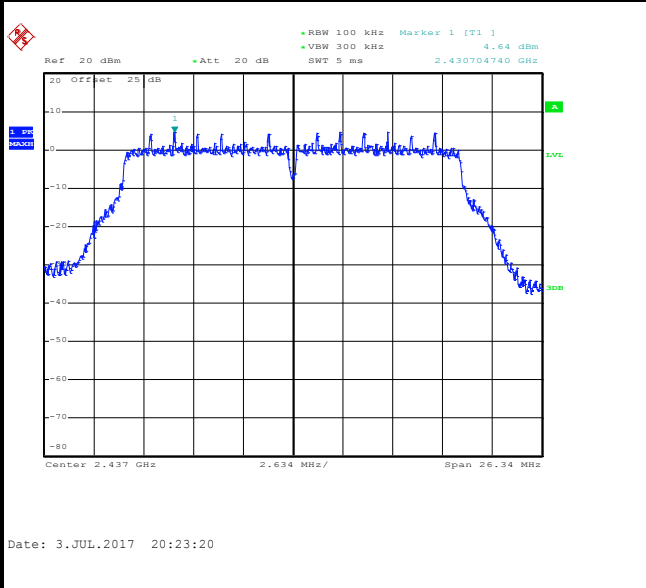

Spurious Emission 30MHz~3GHz

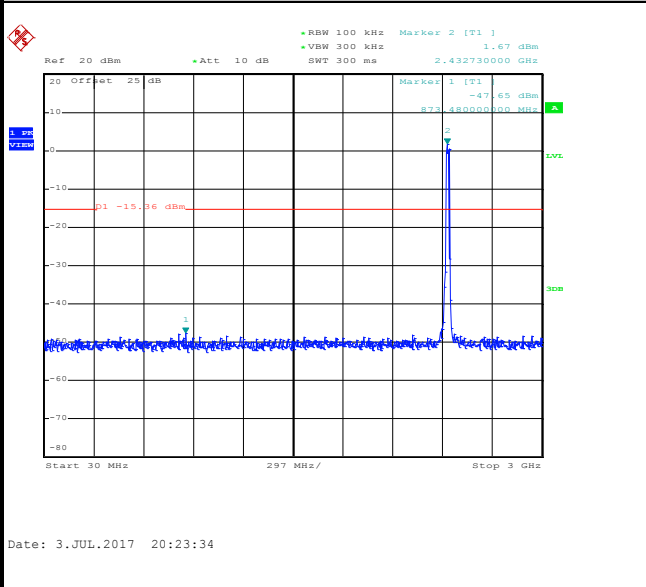

Spurious Emission 2GHz~25GHz

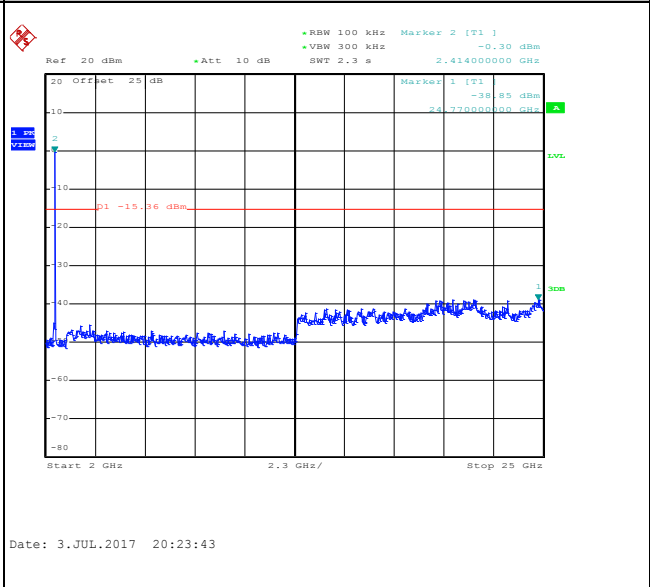



Number of TX :	2	Ant. :	1
Test Mode :	802.11n HT20	Temperature :	21~25°C
Test Band :	2.4GHz High	Relative Humidity :	51~54%
Test Channel :	11	Test Engineer :	Tommy Lee / Aking Chang

WLAN 802.11n HT20 Channel 11

100kHz PSD reference Level



High Channel Plot

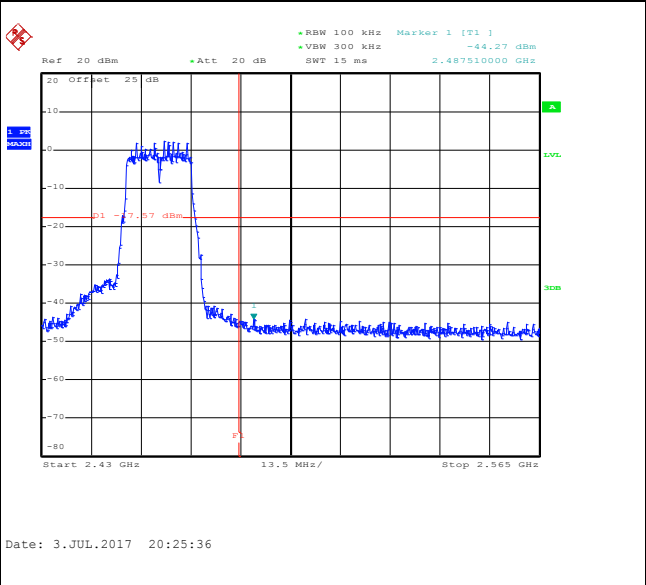

Spurious Emission 30MHz~3GHz

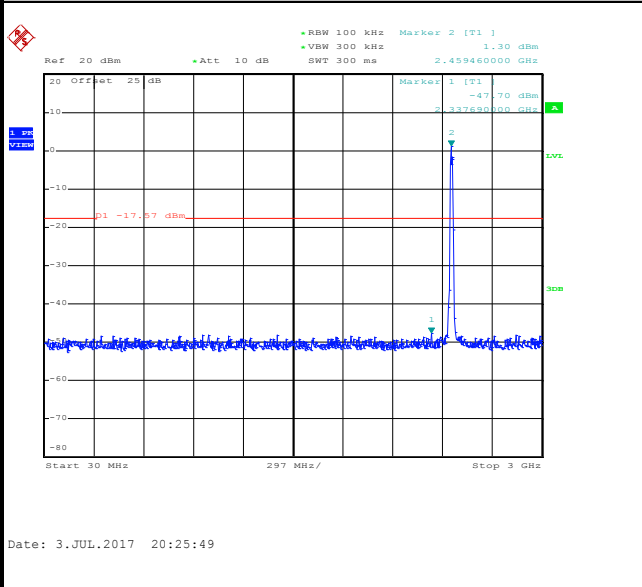

Spurious Emission 2GHz~25GHz

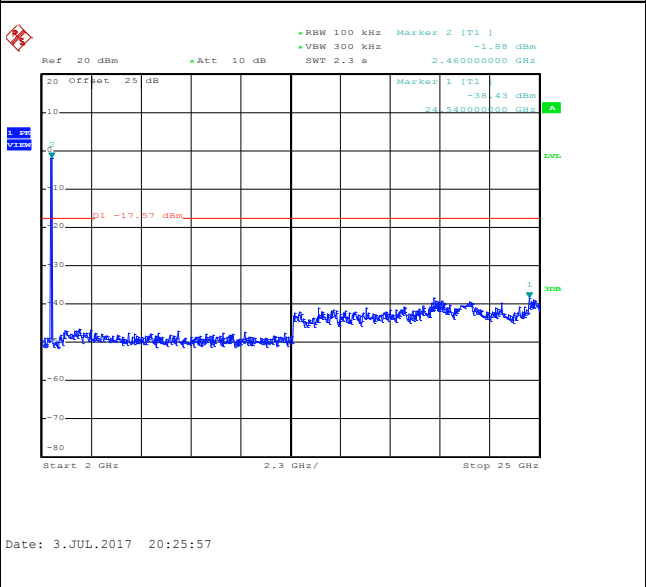



Number of TX :	2	Ant. :	1
Test Mode :	802.11n HT20	Temperature :	21~25°C
Test Band :	2.4GHz High	Relative Humidity :	51~54%
Test Channel :	12	Test Engineer :	Tommy Lee / Aking Chang

WLAN 802.11n HT20 Channel 12

100kHz PSD reference Level

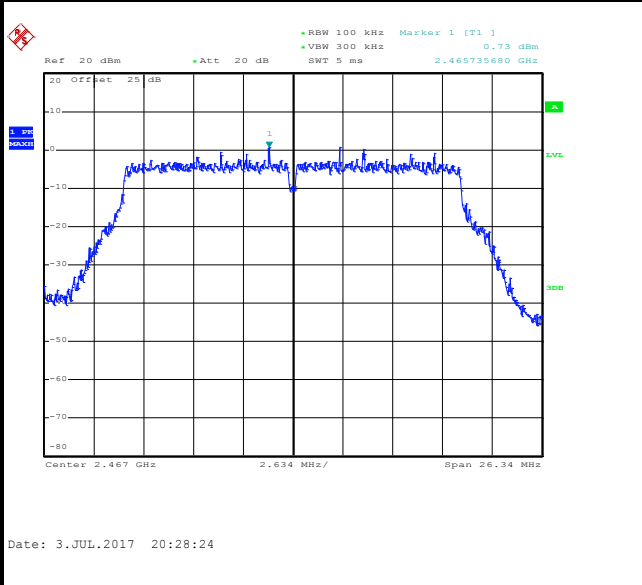

High Channel Plot

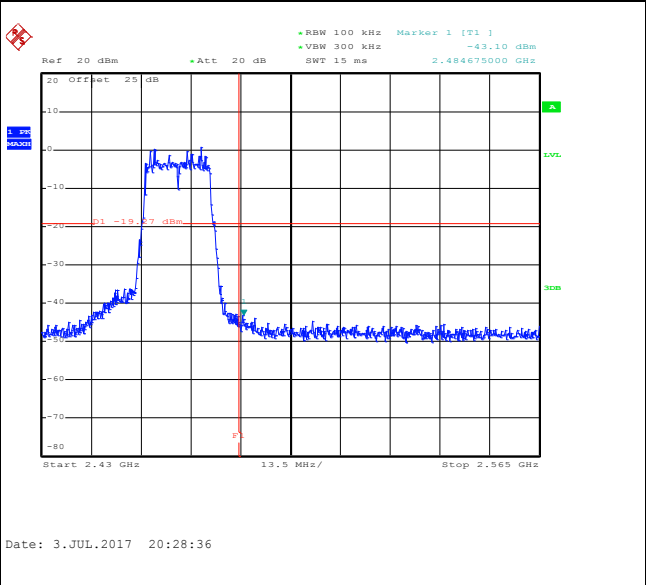

Spurious Emission 30MHz~3GHz

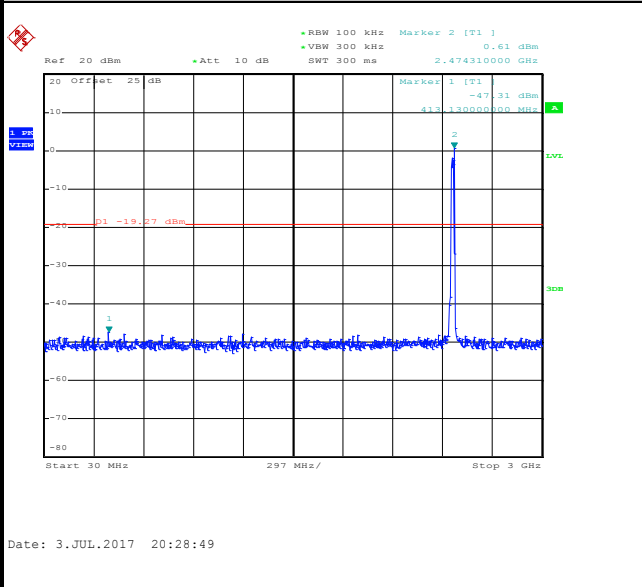

Spurious Emission 2GHz~25GHz

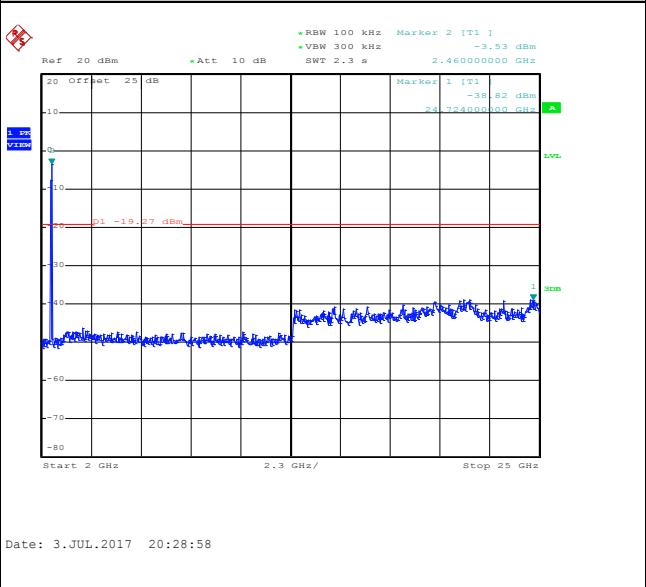



Number of TX :	2	Ant. :	1
Test Mode :	802.11n HT20	Temperature :	21~25°C
Test Band :	2.4GHz High	Relative Humidity :	51~54%
Test Channel :	13	Test Engineer :	Tommy Lee / Aking Chang

WLAN 802.11n HT20 Channel 13

100kHz PSD reference Level

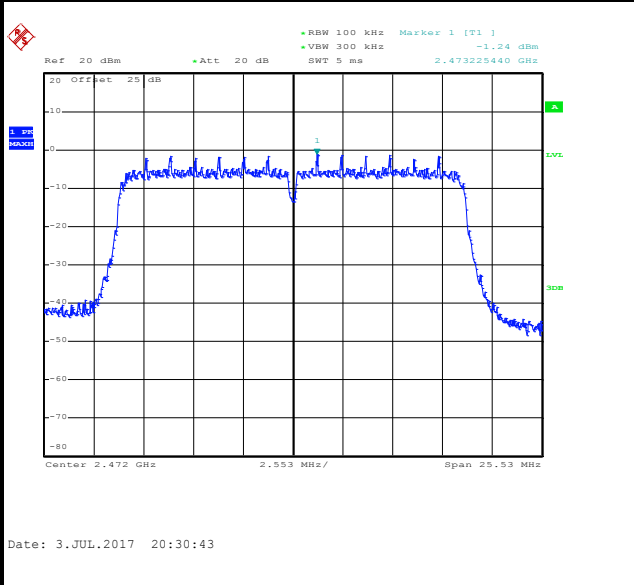

High Channel Plot

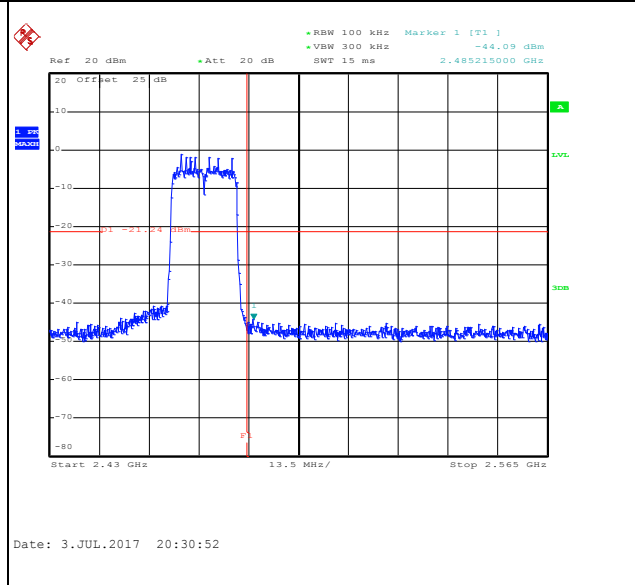

Spurious Emission 30MHz~3GHz

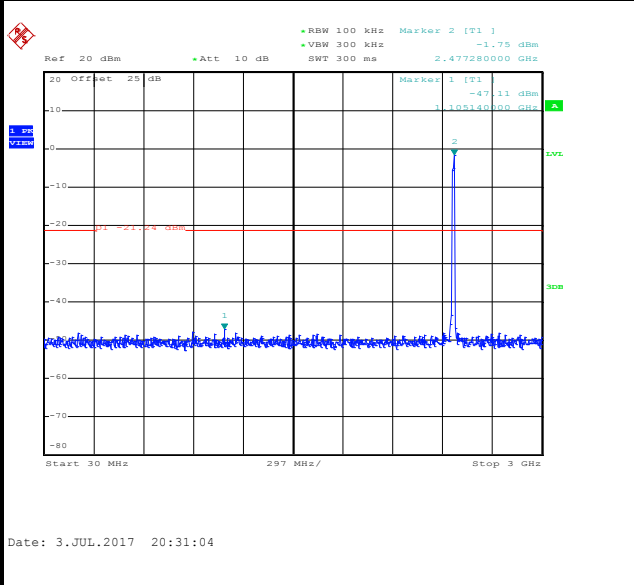

Spurious Emission 2GHz~25GHz

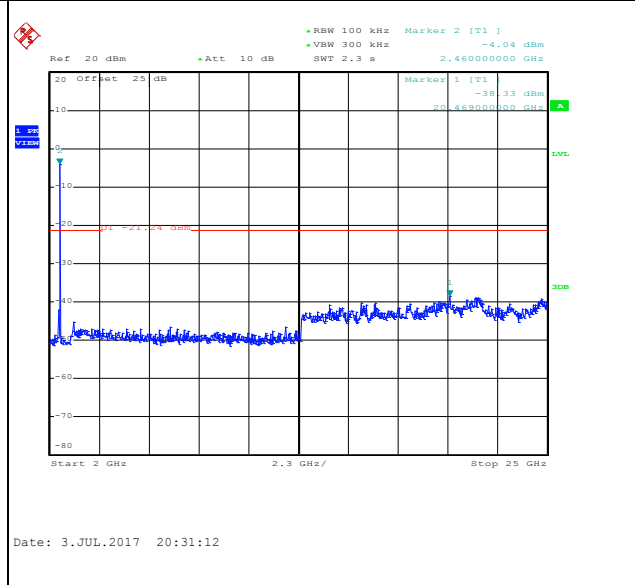



Number of TX = 2, Ant. 2 (Measured)

Number of TX :	2	Ant. :	2
Test Mode :	802.11g	Temperature :	21~25°C
Test Band :	2.4GHz Low	Relative Humidity :	51~54%
Test Channel :	01	Test Engineer :	Tommy Lee / Aking Chang

WLAN 802.11g Channel 01

100kHz PSD reference Level

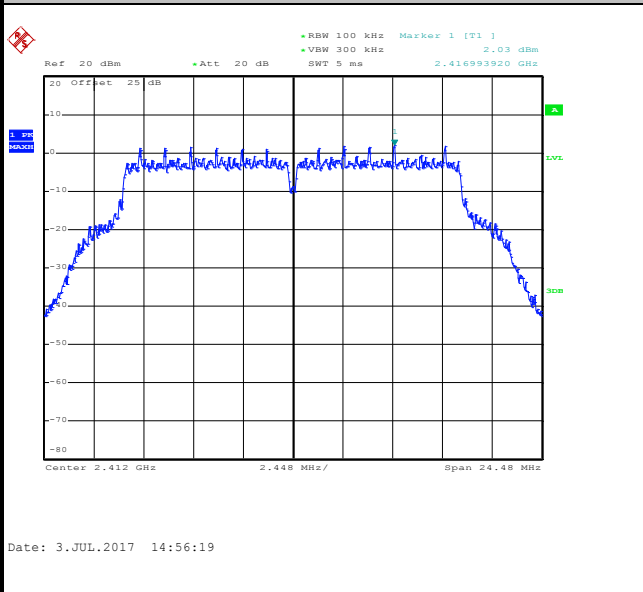

Low Channel Plot

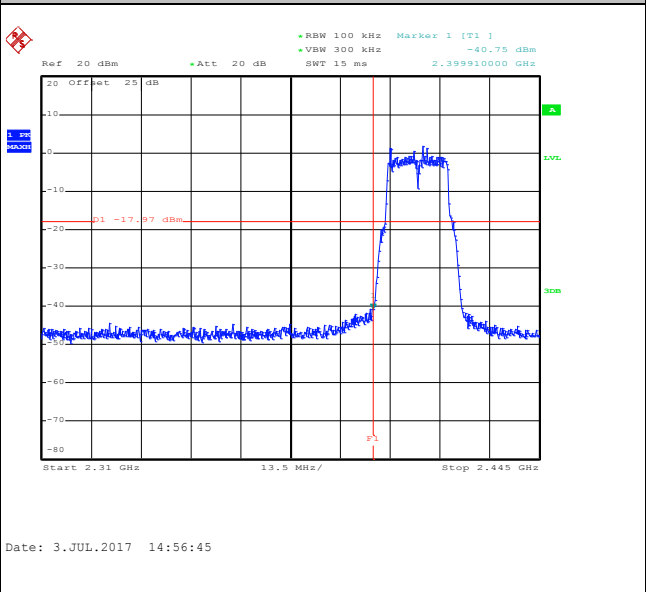

Spurious Emission 30MHz~3GHz

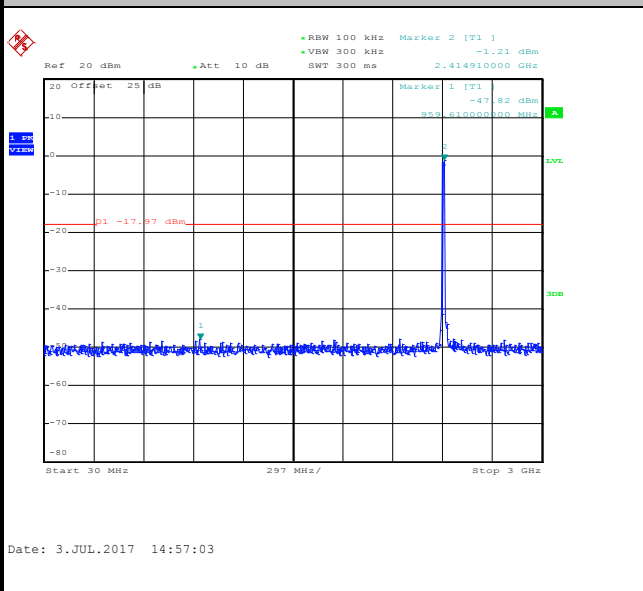

Spurious Emission 2GHz~25GHz

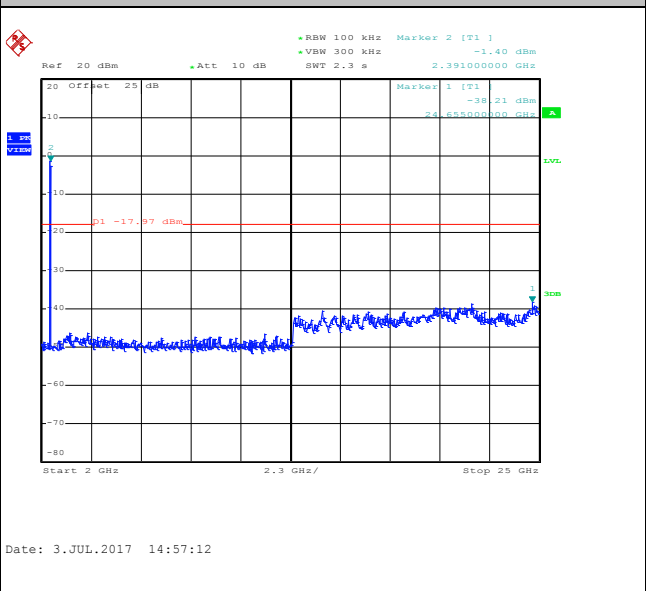



Number of TX :	2	Ant. :	2
Test Mode :	802.11g	Temperature :	21~25°C
Test Band :	2.4GHz Mid	Relative Humidity :	51~54%
Test Channel :	06	Test Engineer :	Tommy Lee / Aking Chang

WLAN 802.11g Channel 06

100kHz PSD reference Level

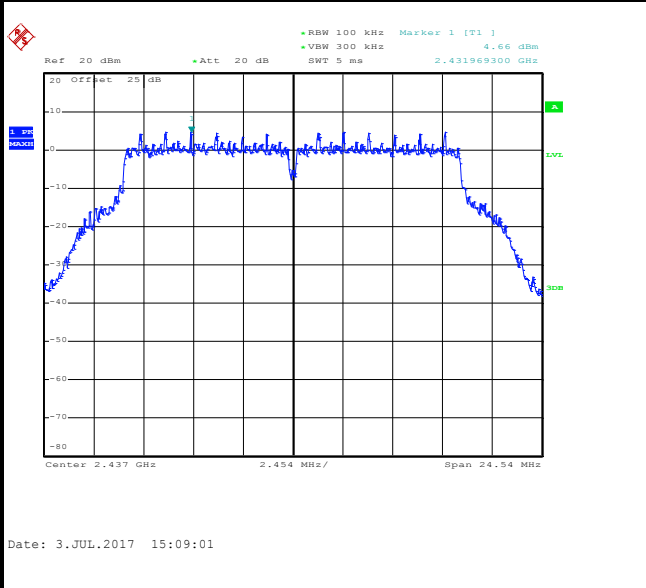

Spurious Emission 30MHz~3GHz

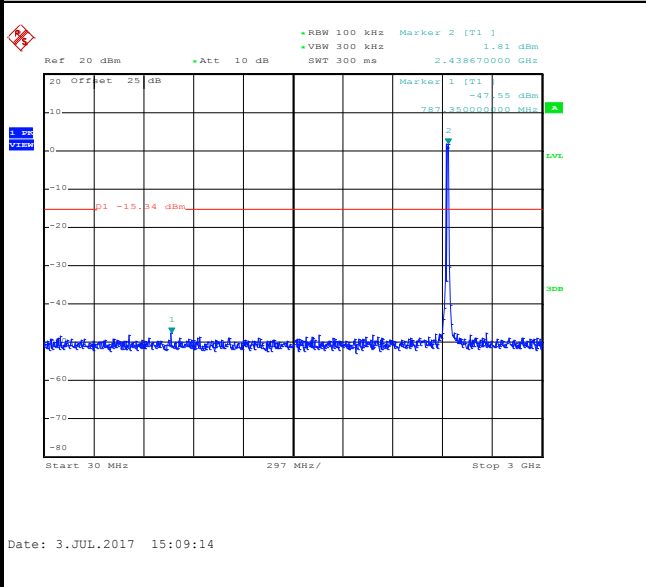

Spurious Emission 2GHz~25GHz

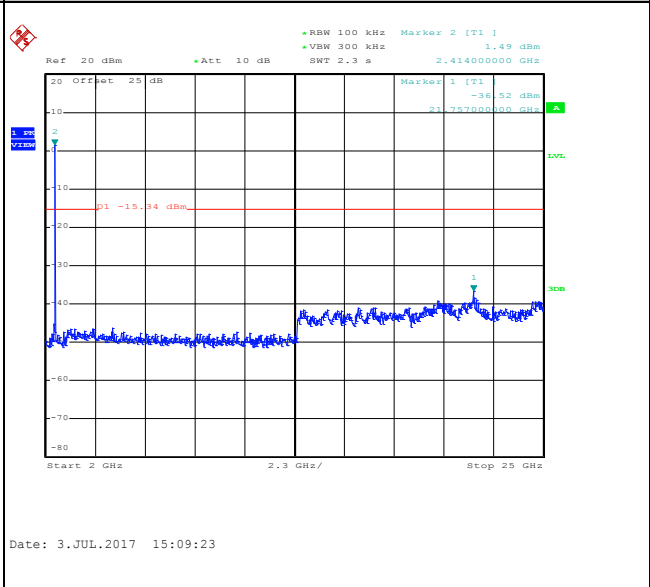



Number of TX :	2	Ant. :	2
Test Mode :	802.11g	Temperature :	21~25°C
Test Band :	2.4GHz High	Relative Humidity :	51~54%
Test Channel :	11	Test Engineer :	Tommy Lee / Aking Chang

WLAN 802.11g Channel 11

100kHz PSD reference Level

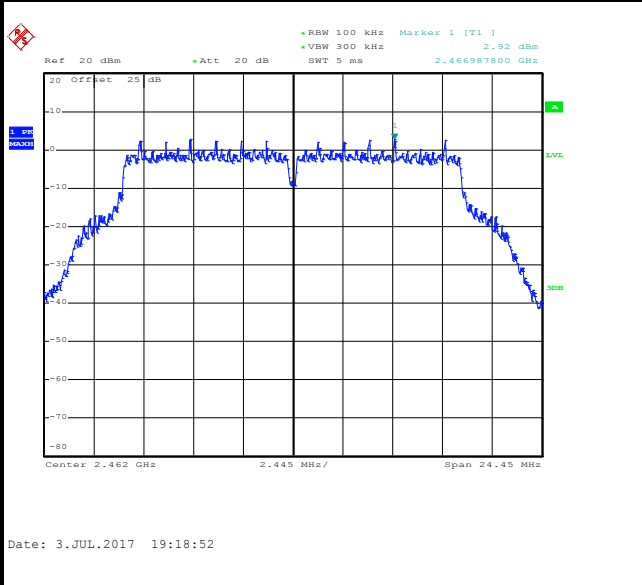

High Channel Plot

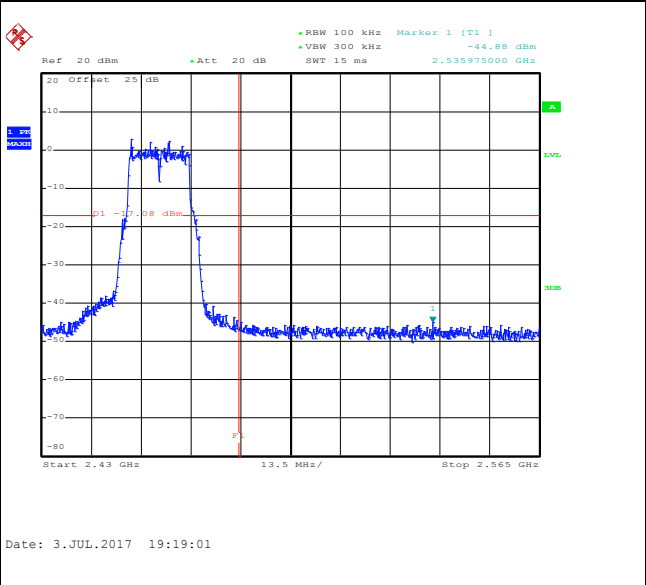

Spurious Emission 30MHz~3GHz

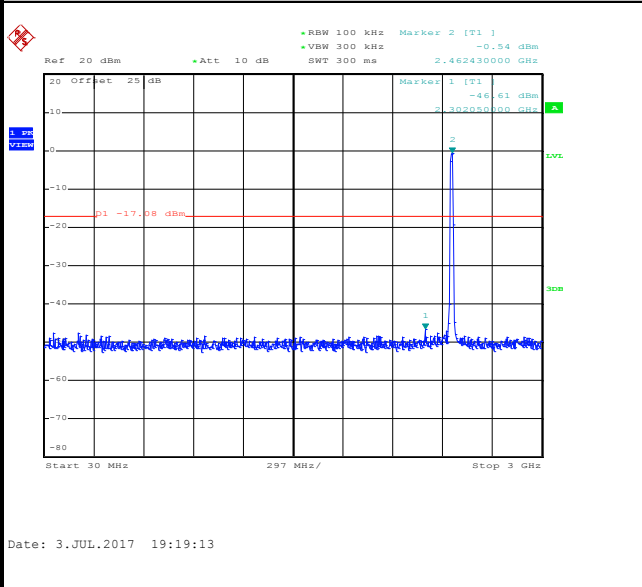

Spurious Emission 2GHz~25GHz

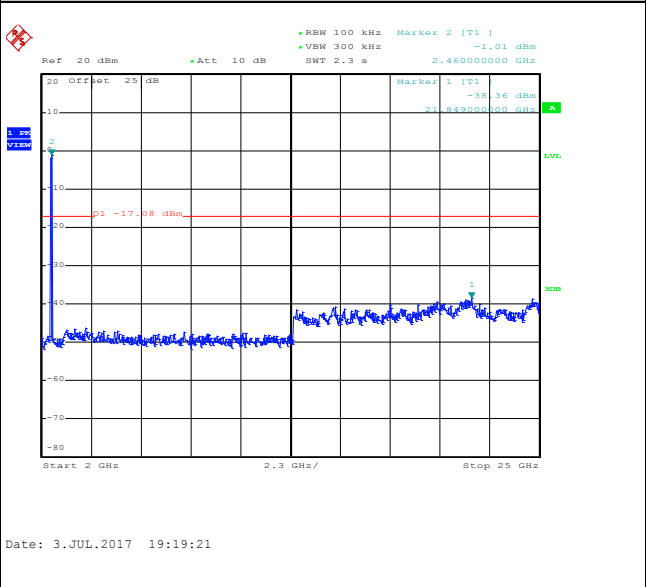



Number of TX :	2	Ant. :	2
Test Mode :	802.11g	Temperature :	21~25°C
Test Band :	2.4GHz High	Relative Humidity :	51~54%
Test Channel :	12	Test Engineer :	Tommy Lee / Aking Chang

WLAN 802.11g Channel 12

100kHz PSD reference Level

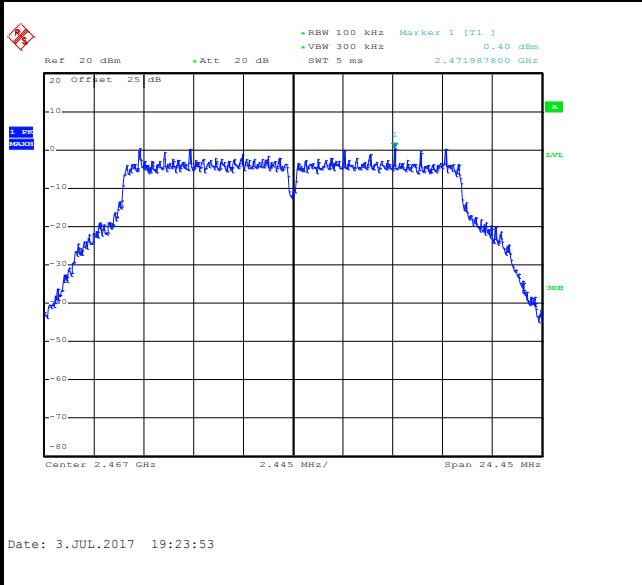

High Channel Plot

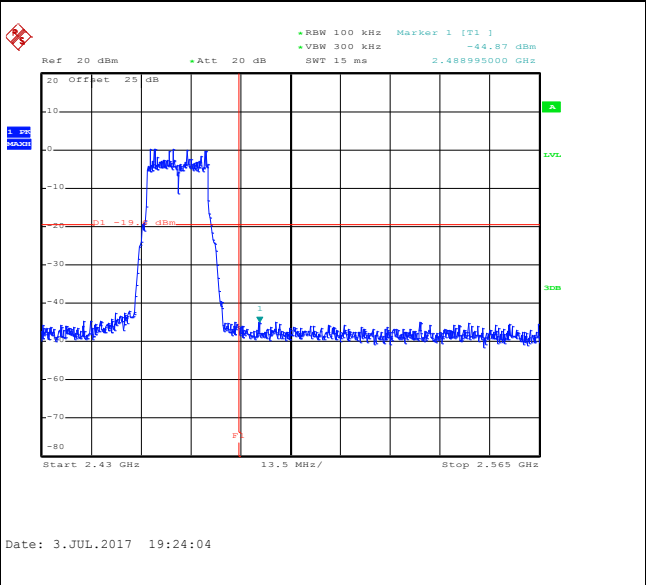

Spurious Emission 30MHz~3GHz

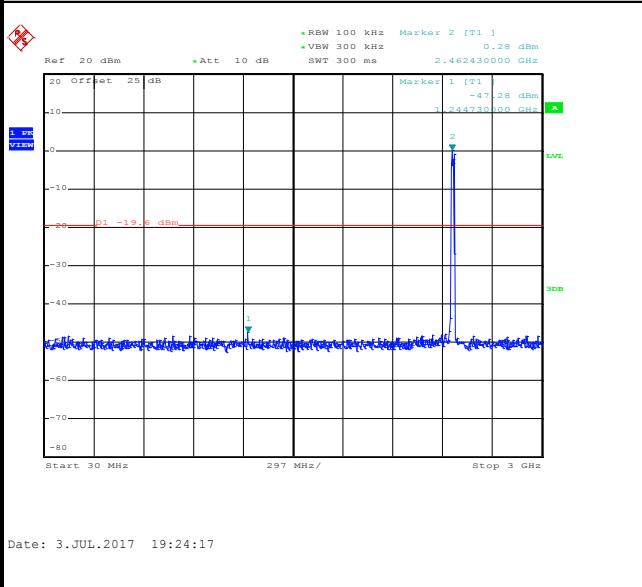

Spurious Emission 2GHz~25GHz

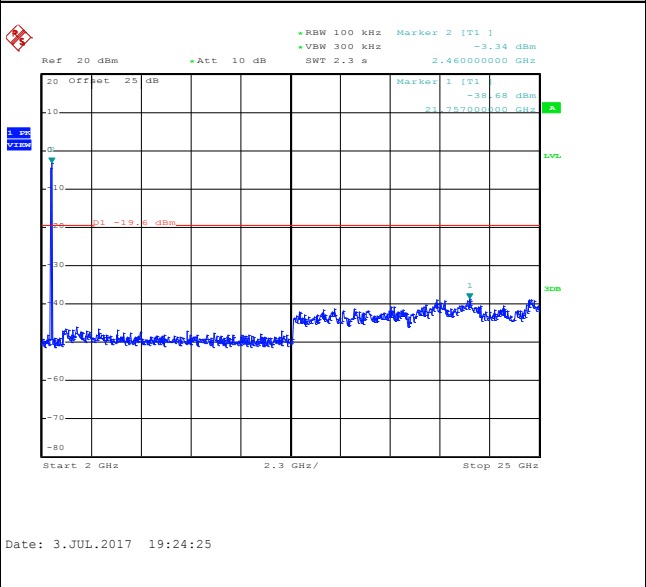



Number of TX :	2	Ant. :	2
Test Mode :	802.11g	Temperature :	21~25°C
Test Band :	2.4GHz High	Relative Humidity :	51~54%
Test Channel :	13	Test Engineer :	Tommy Lee / Aking Chang

WLAN 802.11g Channel 13

100kHz PSD reference Level

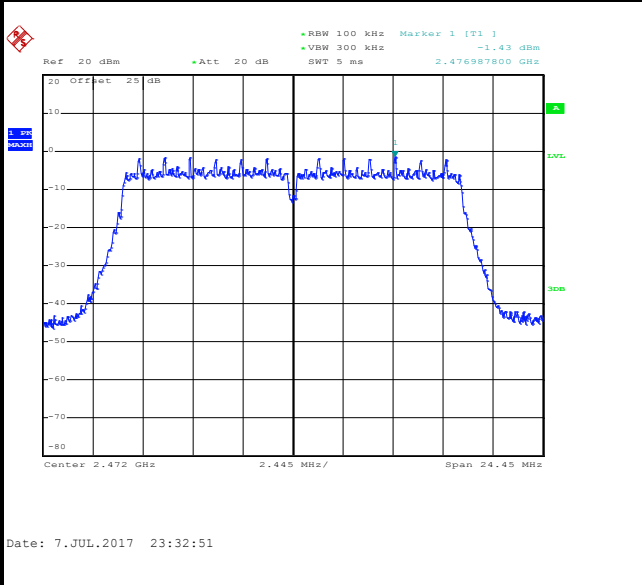

High Channel Plot

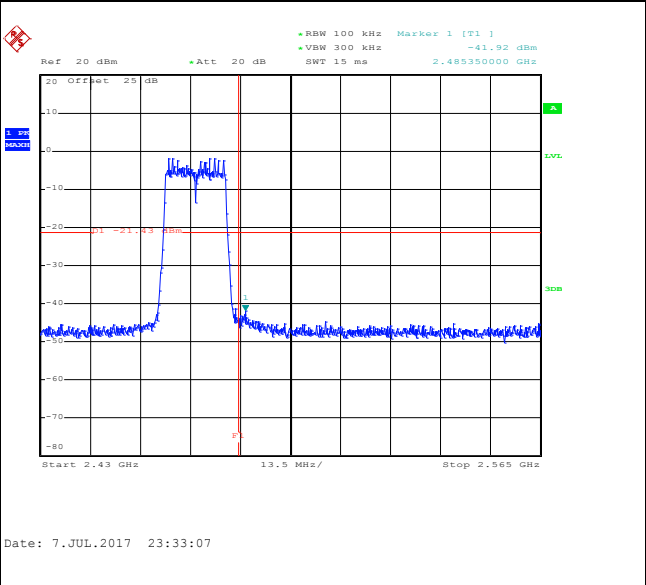

Spurious Emission 30MHz~3GHz

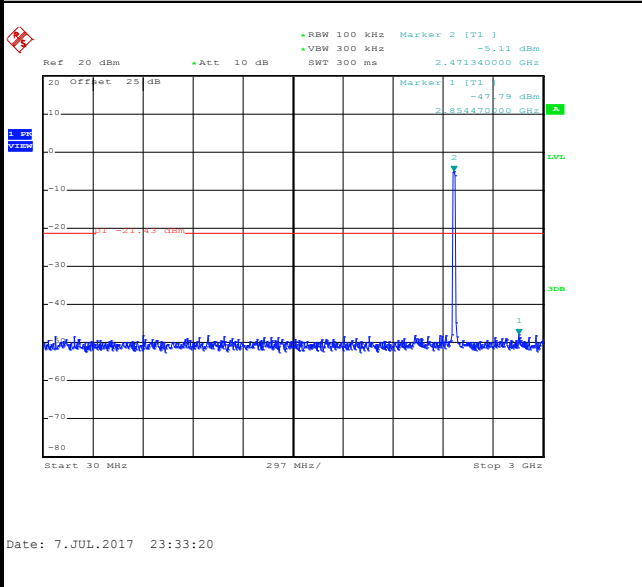

Spurious Emission 2GHz~25GHz

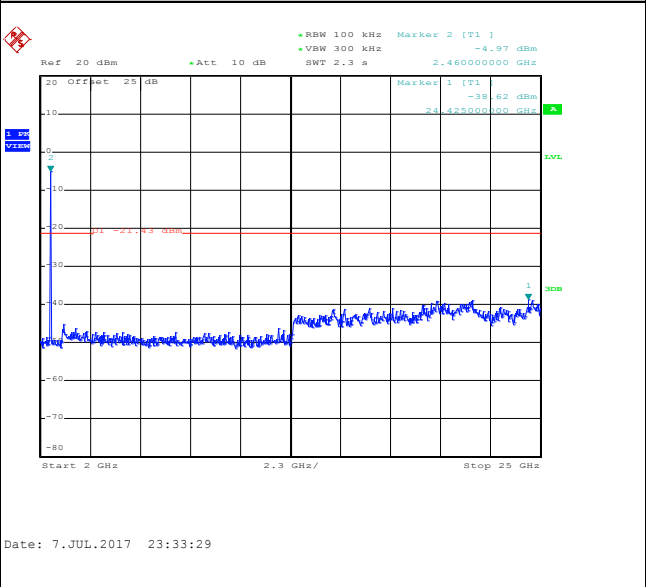



Number of TX :	2	Ant. :	2
Test Mode :	802.11n HT20	Temperature :	21~25°C
Test Band :	2.4GHz Low	Relative Humidity :	51~54%
Test Channel :	01	Test Engineer :	Tommy Lee / Aking Chang

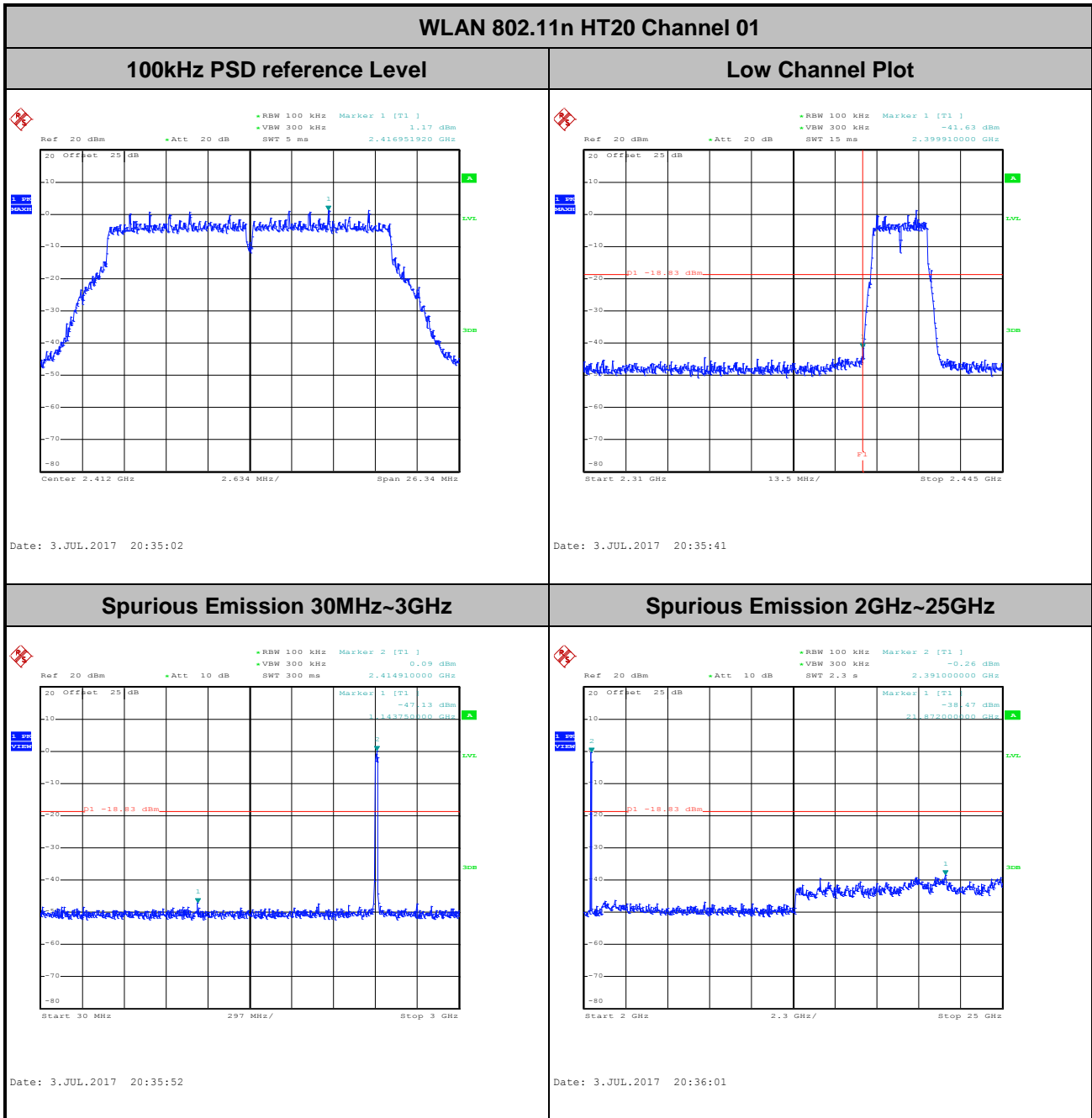



Number of TX :	2	Ant. :	2
Test Mode :	802.11n HT20	Temperature :	21~25°C
Test Band :	2.4GHz Mid	Relative Humidity :	51~54%
Test Channel :	06	Test Engineer :	Tommy Lee / Aking Chang

WLAN 802.11n HT20 Channel 06

100kHz PSD reference Level

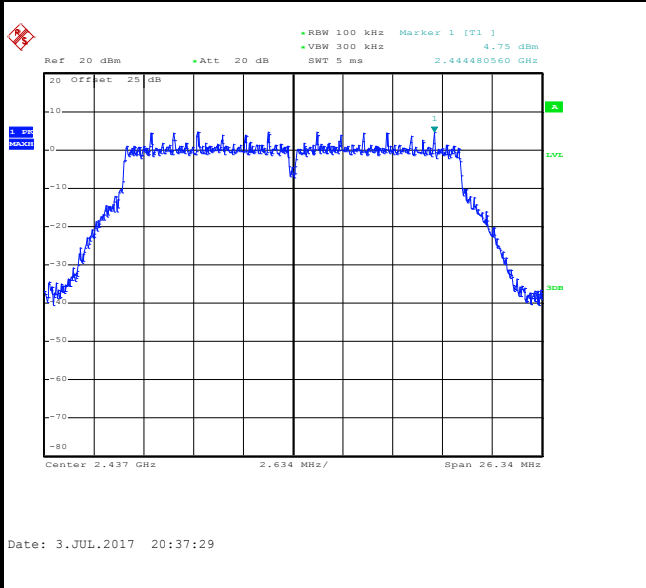

Spurious Emission 30MHz~3GHz

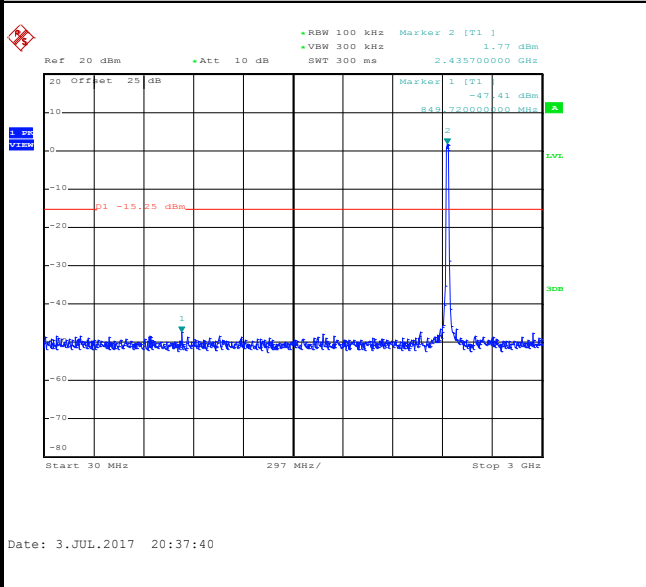

Spurious Emission 2GHz~25GHz

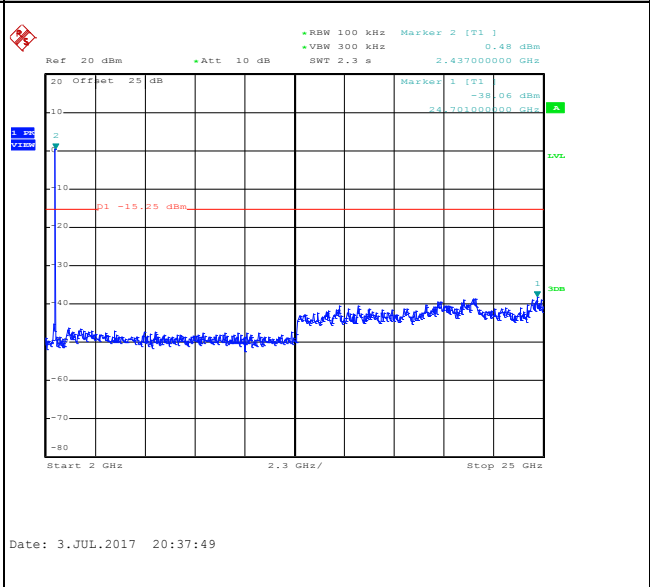



Number of TX :	2	Ant. :	2
Test Mode :	802.11n HT20	Temperature :	21~25°C
Test Band :	2.4GHz High	Relative Humidity :	51~54%
Test Channel :	11	Test Engineer :	Tommy Lee / Aking Chang

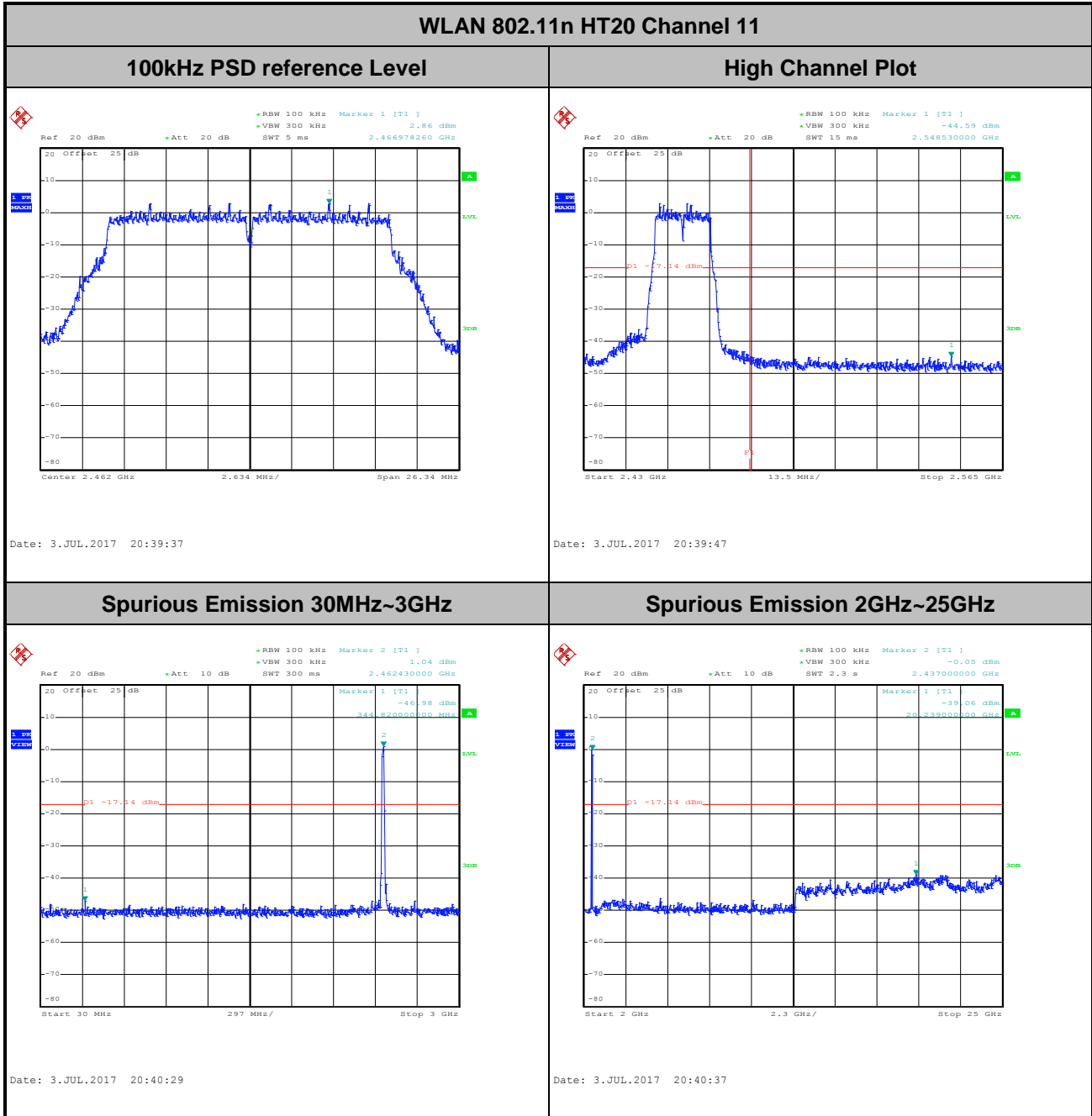



Number of TX :	2	Ant. :	2
Test Mode :	802.11n HT20	Temperature :	21~25°C
Test Band :	2.4GHz High	Relative Humidity :	51~54%
Test Channel :	12	Test Engineer :	Tommy Lee / Aking Chang

WLAN 802.11n HT20 Channel 12

100kHz PSD reference Level

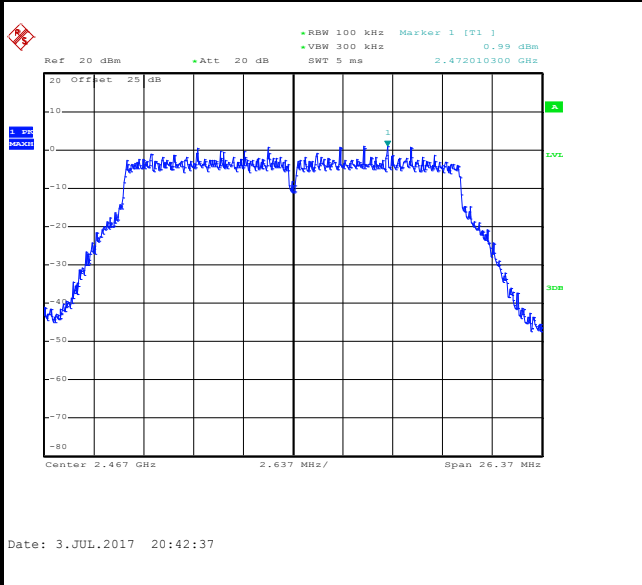

High Channel Plot

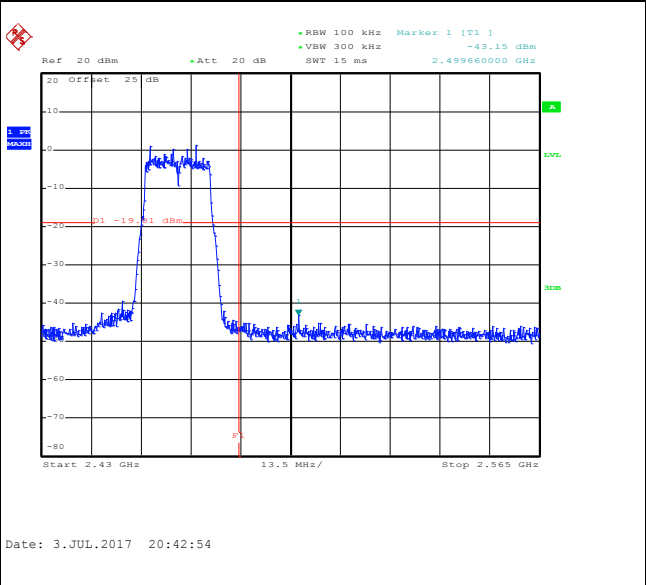

Spurious Emission 30MHz~3GHz

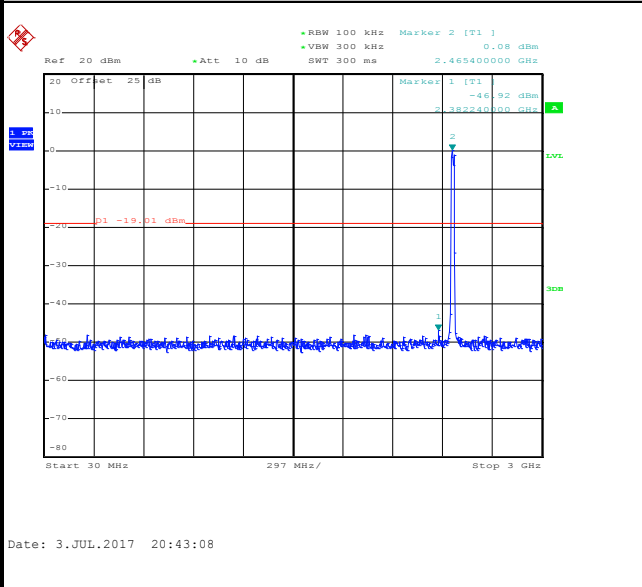

Spurious Emission 2GHz~25GHz

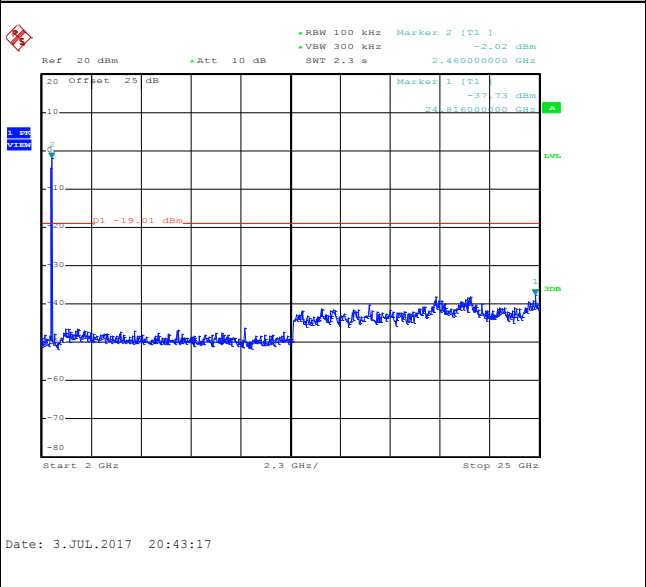



Number of TX :	2	Ant. :	2
Test Mode :	802.11n HT20	Temperature :	21~25°C
Test Band :	2.4GHz High	Relative Humidity :	51~54%
Test Channel :	13	Test Engineer :	Tommy Lee / Aking Chang

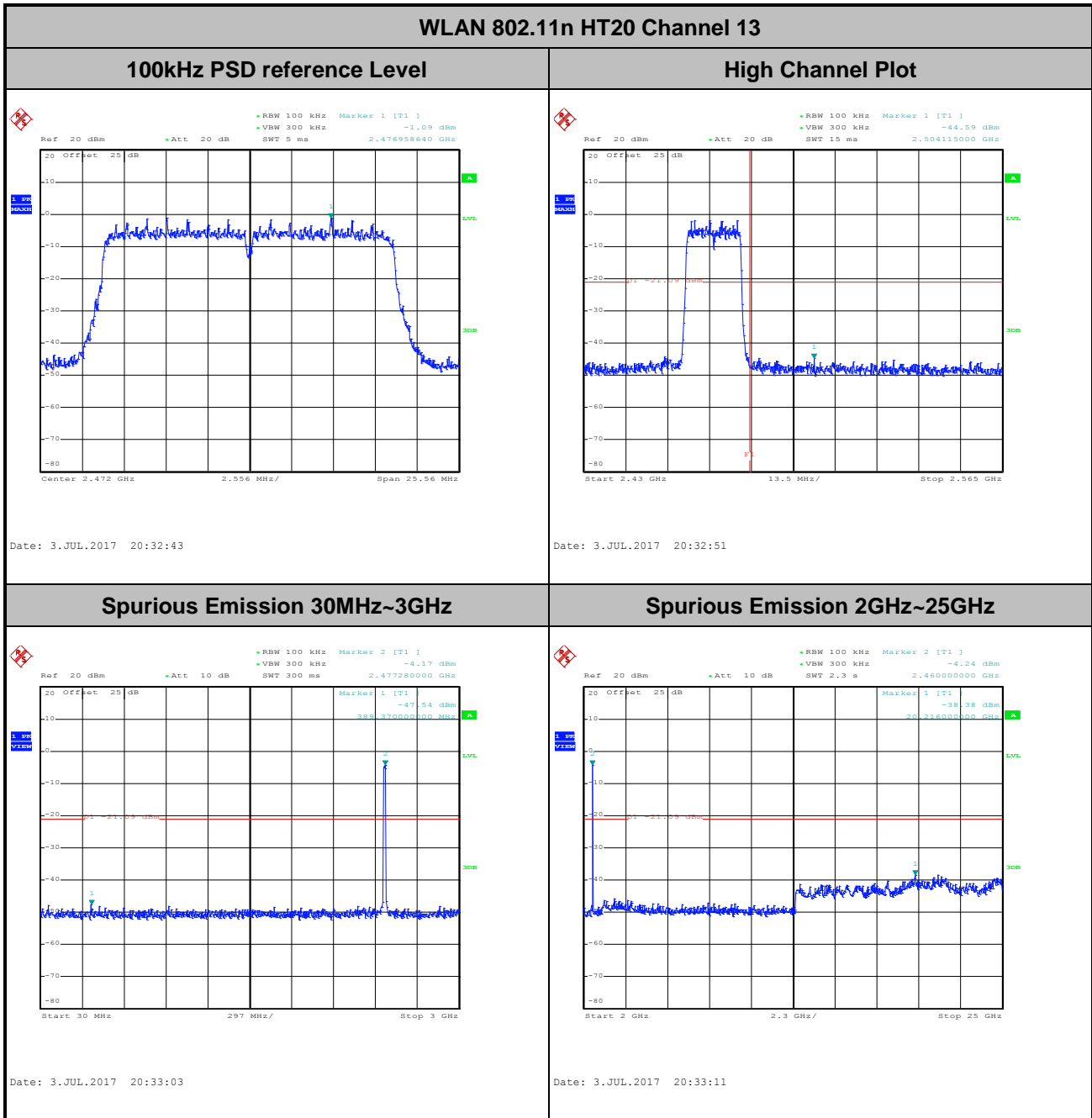



3.5 Radiated Band Edges and Spurious Emission Measurement

3.5.1 Limit of Radiated band edge and Spurious Emission Measurement

In any 100 kHz bandwidth outside the intentional radiator frequency band, all harmonics/spurious must be at least 20 dB below the highest emission level within the authorized band. If the output power of this device was measured by spectrum analyzer, the attenuation under this paragraph shall be 30 dB instead of 20 dB. In addition, radiated emissions which fall in the restricted bands must also comply with the limits as below.

Frequency (MHz)	Field Strength (microvolts/meter)	Measurement Distance (meters)
0.009 – 0.490	2400/F(kHz)	300
0.490 – 1.705	24000/F(kHz)	30
1.705 – 30.0	30	30
30 – 88	100	3
88 – 216	150	3
216 - 960	200	3
Above 960	500	3

3.5.2 Measuring Instruments

The measuring equipment is listed in the section 4 of this test report.



3.5.3 Test Procedures

1. The testing follows FCC KDB Publication No. 558074 D01 DTS Meas. Guidance v04.
2. The EUT was arranged to its worst case and then tune the antenna tower (from 1 m to 4 m) and turntable (from 0 degree to 360 degrees) to find the maximum reading. A pre-amp and a high pass filter are used for the test in order to get better signal level.
3. The EUT was placed on a turntable with 0.8 meter for frequency below 1GHz and 1.5 meter for frequency above 1GHz respectively above ground.
4. The EUT was set 3 meters from the interference receiving antenna, which was mounted on the top of a variable height antenna tower.
5. Corrected Reading: Antenna Factor + Cable Loss + Read Level - Preamp Factor = Level
6. For measurement below 1GHz, If the emission level of the EUT measured by the peak detector is 3 dB lower than the applicable limit, the peak emission level will be reported. Otherwise, the emission measurement will be repeated using the quasi-peak detector and reported.
7. Use the following spectrum analyzer settings:
 - (1) Span shall wide enough to fully capture the emission being measured;
 - (2) Set RBW=100 kHz for $f < 1$ GHz; VBW \geq RBW; Sweep = auto; Detector function = peak; Trace = max hold;
 - (3) Set RBW = 1 MHz, VBW= 3MHz for $f \geq 1$ GHz for peak measurement.
For average measurement:
 - VBW = 10 Hz, when duty cycle is no less than 98 percent.
 - VBW $\geq 1/T$, when duty cycle is less than 98 percent where T is the minimum transmission duration over which the transmitter is on and is transmitting at its maximum power control level for the tested mode of operation.

3.5.4 Test Setup

For radiated emissions below 30MHz

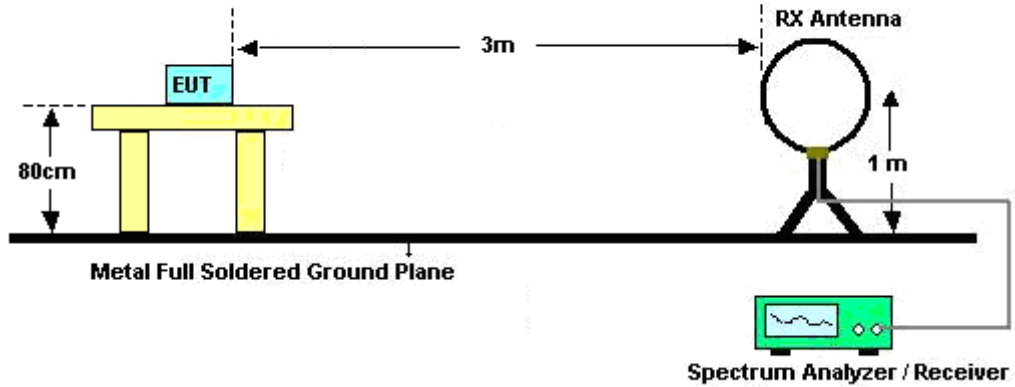

For radiated emissions from 30MHz to 1GHz

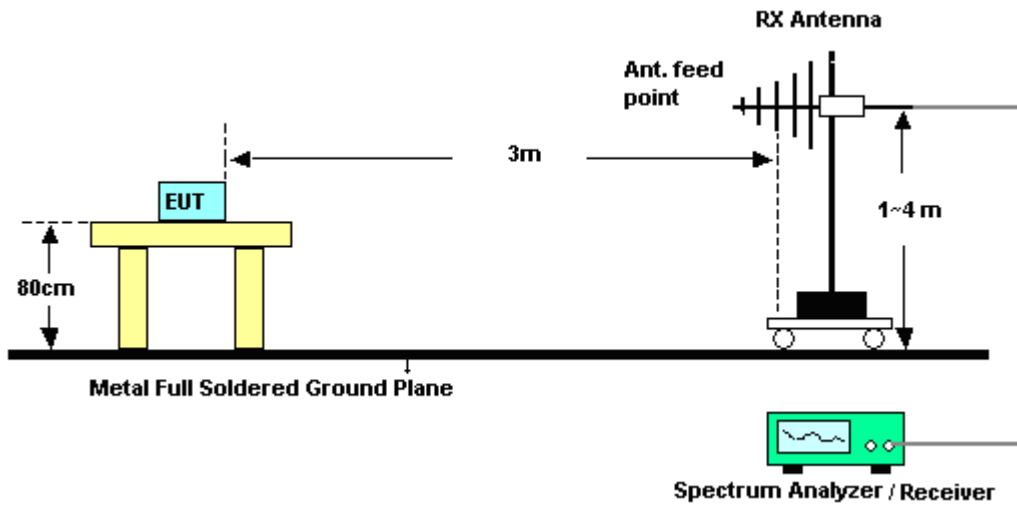

For radiated emissions above 1GHz

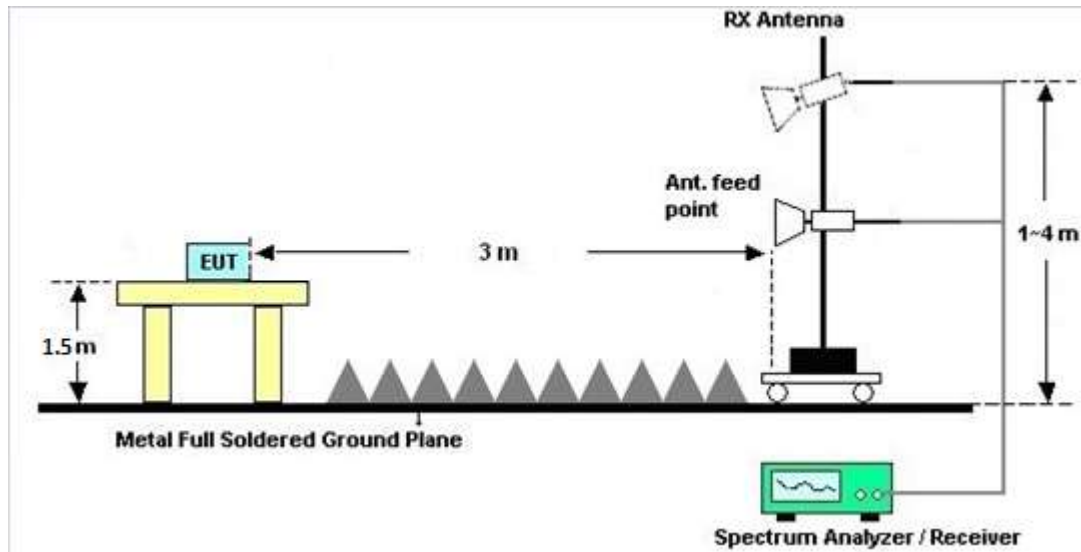

3.5.5 Test Results of Radiated Spurious Emissions (9kHz ~ 30MHz)

The low frequency, which started from 9 kHz to 30MHz, was pre-scanned and the result which was 20dB lower than the limit line was not reported.

There is a comparison data of both open-field test site and semi-Anechoic chamber, and the result came out very similar.

3.5.6 Test Result of Radiated Spurious at Band Edges

Please refer to Appendix C and D.

3.5.7 Duty Cycle

Please refer to Appendix E.

3.5.8 Test Result of Radiated Spurious Emission (30MHz ~ 10th Harmonic)

Please refer to Appendix C and D.



3.6 AC Conducted Emission Measurement

3.6.1 Limit of AC Conducted Emission

For equipment that is designed to be connected to the public utility (AC) power line, the radio frequency voltage that is conducted back onto the AC power line on any frequency or frequencies within the band 150 kHz to 30 MHz shall not exceed the limits in the following table.

Frequency of Emission (MHz)	Conducted Limit (dB μ V)	
	Quasi-Peak	Average
0.15-0.5	66 to 56*	56 to 46*
0.5-5	56	46
5-30	60	50

*Decreases with the logarithm of the frequency.

3.6.2 Measuring Instruments

The measuring equipment is listed in the section 4 of this test report.

3.6.3 Test Procedures

1. The EUT was placed 0.4 meter from the conducting wall of the shielding room, and it was kept at least 80 centimeters from any other grounded conducting surface.
2. Connect EUT to the power mains through a line impedance stabilization network (LISN).
3. All the support units are connecting to the other LISN.
4. The LISN provides 50 ohm coupling impedance for the measuring instrument.
5. The FCC states that a 50 ohm, 50 microhenry LISN should be used.
6. Both sides of AC line were checked for maximum conducted interference.
7. The frequency range from 150 kHz to 30 MHz was searched.
8. Set the test-receiver system to Peak Detect Function and specified bandwidth (IF bandwidth = 9kHz) with Maximum Hold Mode.

3.6.4 Test Setup

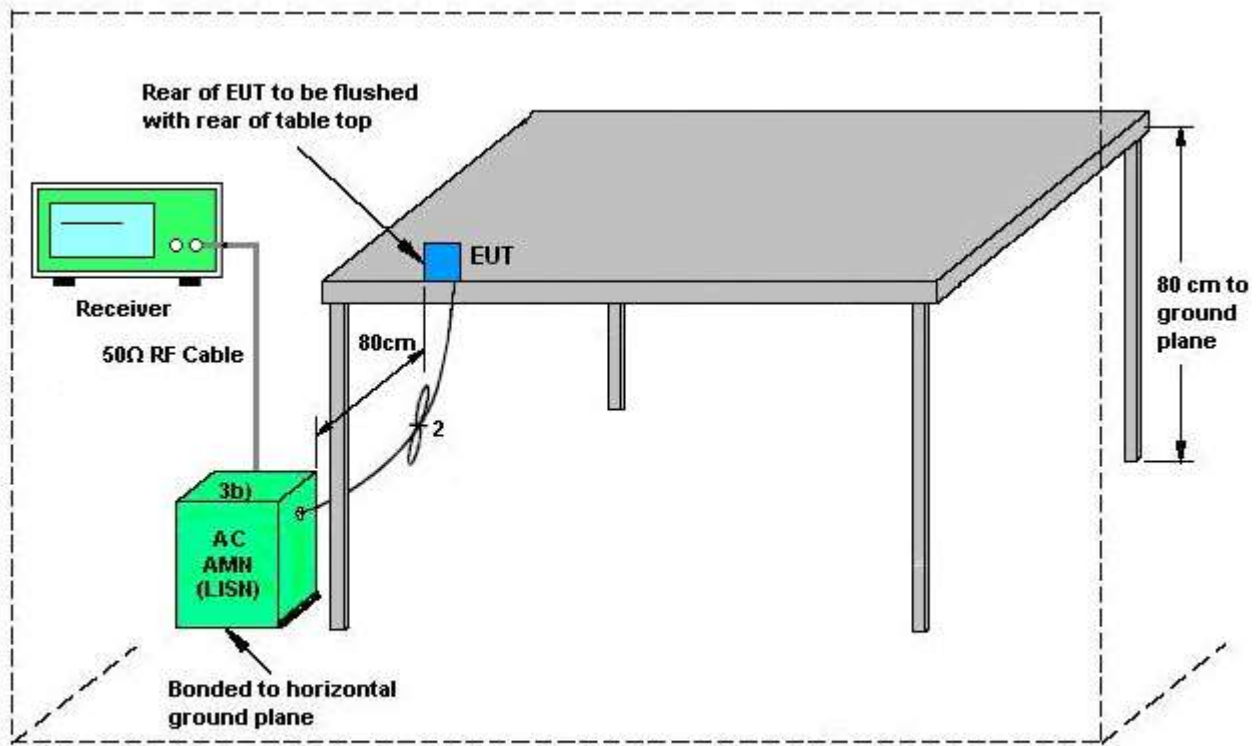

AMN = Artificial mains network (LISN)
 AE = Associated equipment
 EUT = Equipment under test
 ISN = Impedance stabilization network

3.6.5 Test Result of AC Conducted Emission

Please refer to Appendix B



3.7 Antenna Requirements

3.7.1 Standard Applicable

If directional gain of transmitting Antennas is greater than 6dBi, the power shall be reduced by the same level in dB comparing to gain minus 6dBi. For the fixed point-to-point operation, the power shall be reduced by one dB for every 3 dB that the directional gain of the Antenna exceeds 6 dBi. The use of a permanently attached Antenna or of an Antenna that uses a unique coupling to the intentional radiator shall be considered sufficient to comply with the rule.

3.7.2 Antenna Anti-Replacement Construction

An embedded-in antenna design is used.

3.7.3 Antenna Gain

FCC KDB 662911 D01 Multiple Transmitter Output v02r01

For CDD transmissions, directional gain is calculated as

Directional gain = $G_{ANT} + \text{Array Gain}$, where Array Gain is as follows.

For power spectral density (PSD) measurements on all devices,

Array Gain = $10 \log(N_{ANT}/N_{SS}=1)$ dB.

For power measurements on IEEE 802.11 devices,

Array Gain = 0 dB (i.e., no array gain) for $N_{ANT} \leq 4$.

Directional gain may be calculated by using the formulas applicable to equal gain antennas with G_{ANT} set equal to the gain of the antenna having the highest gain;

The EUT supports CDD mode.

For power, the directional gain G_{ANT} is set equal to the antenna having the highest gain, i.e., F)2)f)i).

For PSD, the directional gain calculation is following F)2)f)ii) of KDB 662911 D01 v02r01.

The power and PSD limit should be modified if the directional gain of EUT is over 6 dBi,

The directional gain "DG" is calculated as following table.

	Ant. 1 (dBi)	Ant. 2 (dBi)	DG for Power (dBi)	DG for PSD (dBi)	Power Limit Reduction (dB)	PSD Limit Reduction (dB)
2.4 GHz	4.78	4.68	4.78	7.74	0.00	1.74

$Power\ Limit\ Reduction = DG(Power) - 6dBi, (min = 0)$

$PSD\ Limit\ Reduction = DG(PSD) - 6dBi, (min = 0)$



4 List of Measuring Equipment

Instrument	Manufacturer	Model No.	Serial No.	Characteristics	Calibration Date	Test Date	Due Date	Remark
Power Meter	Anritsu	ML2495A	0932001	N/A	Sep. 29, 2016	Jun. 13, 2017 ~ Jul. 03, 2017	Sep. 28, 2017	Conducted (TH05-HY)
Power Sensor	Anritsu	MA2411B	0846202	300MHz~40GHz z	Sep. 29, 2016	Jun. 13, 2017 ~ Jul. 03, 2017	Sep. 28, 2017	Conducted (TH05-HY)
Spectrum Analyzer	Rohde & Schwarz	FSP40	100057	9kHz-40GHz	Nov. 25, 2016	Jun. 13, 2017 ~ Jun. 21, 2017	Nov. 24, 2017	Conducted (TH05-HY)
AC Power Source	ChainTek	APC-1000W	N/A	N/A	N/A	Jun. 07, 2017	N/A	Conduction (CO05-HY)
EMI Test Receiver	Rohde & Schwarz	ESCI 7	100724	9kHz~7GHz	Aug. 30, 2016	Jun. 07, 2017	Aug. 29, 2017	Conduction (CO05-HY)
LISN	Rohde & Schwarz	ENV216	100080	9kHz~30MHz	Nov. 29, 2016	Jun. 07, 2017	Nov. 28, 2017	Conduction (CO05-HY)
LISN	Rohde & Schwarz	ENV216	100081	9kHz~30MHz	Dec. 06, 2016	Jun. 07, 2017	Dec. 05, 2017	Conduction (CO05-HY)
EMI Test Receiver	Rohde & Schwarz	ESU26	100390	20Hz~26.5GHz	Dec. 23, 2016	Jun. 14, 2017 ~ Jul. 02, 2017	Dec. 22, 2017	Radiation (03CH12-HY)
Spectrum Analyzer	Agilent	N9030A	MY52350276	3Hz~44GHz	Mar. 23, 2017	Jun. 14, 2017 ~ Jul. 02, 2017	Mar. 22, 2018	Radiation (03CH12-HY)
Loop Antenna	Rohde & Schwarz	HFH2-Z2	100488	9 kHz~30 MHz	Oct. 20, 2016	Jun. 14, 2017 ~ Jul. 02, 2017	Oct. 19, 2018	Radiation (03CH12-HY)
Bilog Antenna	TESEQ	CBL 6111D&00800 N1D01N-06	37059&01	30MHz~1GHz	Oct. 15, 2016	Jun. 14, 2017 ~ Jul. 02, 2017	Oct. 14, 2017	Radiation (03CH12-HY)
Horn Antenna	SCHWARZBECK	BBHA 9120D	9120D-1328	1GHz ~ 18GHz	Oct. 25, 2016	Jun. 14, 2017 ~ Jul. 02, 2017	Oct. 24, 2017	Radiation (03CH12-HY)
SHF-EHF Horn Antenna	SCHWARZBECK	BBHA 9170	BBHA9170576	18GHz ~ 40GHz	Apr. 27, 2017	Jun. 14, 2017 ~ Jul. 02, 2017	Apr. 26, 2018	Radiation (03CH12-HY)
Preamplifier	COM-POWER	PA-103	161075	10MHz~1GHz	Mar. 23, 2017	Jun. 14, 2017 ~ Jul. 02, 2017	Mar. 22, 2018	Radiation (03CH12-HY)
Preamplifier	Keysight	83017A	MY53270148	1GHz~26.5GHz	Jan. 12, 2017	Jun. 14, 2017 ~ Jul. 02, 2017	Jan. 11, 2018	Radiation (03CH12-HY)
Preamplifier	MITEQ	AMF-7D-0010 1800-30-10P	1815698	1GHz~18GHz	Dec. 01, 2016	Jun. 14, 2017 ~ Jul. 02, 2017	Nov. 30, 2017	Radiation (03CH12-HY)
Amplifier	MITEQ	TTA1840-35-HG	1871923	18GHz~40GHz	Jul. 16, 2016	Jun. 14, 2017 ~ Jul. 02, 2017	Jul. 15, 2017	Radiation (03CH12-HY)
Antenna Mast	EMEC	AM-BS-4500-B	N/A	1m~4m	N/A	Jun. 14, 2017 ~ Jul. 02, 2017	N/A	Radiation (03CH12-HY)
Turn Table	EMEC	TT2000	N/A	0~360 Degree	N/A	Jun. 14, 2017 ~ Jul. 02, 2017	N/A	Radiation (03CH12-HY)



5 Uncertainty of Evaluation

Uncertainty of Conducted Emission Measurement (150 kHz ~ 30 MHz)

Measuring Uncertainty for a Level of Confidence of 95% ($U = 2Uc(y)$)	2.70
---	------

Uncertainty of Radiated Emission Measurement (30 MHz ~ 1000 MHz)

Measuring Uncertainty for a Level of Confidence of 95% ($U = 2Uc(y)$)	5.10
---	------

Uncertainty of Radiated Emission Measurement (1000 MHz ~ 18000 MHz)

Measuring Uncertainty for a Level of Confidence of 95% ($U = 2Uc(y)$)	5.20
---	------

Uncertainty of Radiated Emission Measurement (18000 MHz ~ 40000 MHz)

Measuring Uncertainty for a Level of Confidence of 95% ($U = 2Uc(y)$)	4.70
---	------

Appendix A. Test Result of Conducted Test Items

Test Engineer:	Tommy Lee / Aking Chang	Temperature:	21~25	°C
Test Date:	2017/6/13~2017/7/3	Relative Humidity:	51~54	%

TEST RESULTS DATA
6dB and 99% Occupied Bandwidth

2.4GHz Band										
Mod.	Data Rate	NTX	CH.	Freq. (MHz)	99% Occupied BW (MHz)		6dB BW (MHz)		6dB BW Limit (MHz)	Pass/Fail
					Ant 1	Ant 2	Ant 1	Ant 2		
11b	1Mbps	1	1	2412	11.60	11.65	8.04	8.04	0.50	Pass
11b	1Mbps	1	6	2437	11.55	11.70	8.04	8.08	0.50	Pass
11b	1Mbps	1	11	2462	11.55	11.65	8.04	8.04	0.50	Pass
11b	1Mbps	1	12	2467	11.55	11.65	8.02	8.04	0.50	Pass
11b	1Mbps	1	13	2472	11.55	11.65	8.04	8.08	0.50	Pass
11g	6Mbps	1	1	2412	18.25	18.35	16.32	16.28	0.50	Pass
11g	6Mbps	1	6	2437	18.40	18.45	16.32	16.32	0.50	Pass
11g	6Mbps	1	11	2462	18.45	18.15	16.36	16.30	0.50	Pass
11g	6Mbps	1	12	2467	18.20	18.45	16.36	16.30	0.50	Pass
11g	6Mbps	1	13	2472	17.25	17.20	16.32	16.28	0.50	Pass
HT20	MCS0	1	1	2412	19.05	18.80	17.54	17.52	0.50	Pass
HT20	MCS0	1	6	2437	19.25	19.25	17.52	17.52	0.50	Pass
HT20	MCS0	1	11	2462	18.95	19.10	17.54	17.54	0.50	Pass
HT20	MCS0	1	12	2467	19.10	19.05	17.56	17.54	0.50	Pass
HT20	MCS0	1	13	2472	18.00	18.00	17.02	16.94	0.50	Pass
11g	6Mbps	2	1	2412	18.35	18.15	16.32	16.32	0.50	Pass
11g	6Mbps	2	6	2437	18.30	18.30	16.36	16.36	0.50	Pass
11g	6Mbps	2	11	2462	18.30	18.00	16.30	16.30	0.50	Pass
11g	6Mbps	2	12	2467	18.40	18.10	16.28	16.30	0.50	Pass
11g	6Mbps	2	13	2472	17.25	17.25	16.32	16.30	0.50	Pass
HT20	MCS0	2	1	2412	19.05	18.75	17.54	17.56	0.50	Pass
HT20	MCS0	2	6	2437	19.05	18.95	17.56	17.56	0.50	Pass
HT20	MCS0	2	11	2462	19.15	19.00	17.56	17.56	0.50	Pass
HT20	MCS0	2	12	2467	19.10	18.90	17.56	17.58	0.50	Pass
HT20	MCS0	2	13	2472	18.00	17.95	17.02	17.04	0.50	Pass

TEST RESULTS DATA
Peak Output Power

2.4GHz Band																
Mod.	Data Rate	N _{TX}	CH.	Freq. (MHz)	Peak Conducted Power (dBm)			Conducted Power Limit (dBm)		DG (dBi)		EIRP Power (dBm)		EIRP Power Limit (dBm)		Pass /Fail
					Ant 1	Ant 2	SUM	Ant 1	Ant 2	Ant 1	Ant 2	Ant 1	Ant 2	Ant 1	Ant 2	
11b	1Mbps	1	1	2412	19.95	20.54		30.00	30.00	4.40	4.68	24.35	25.22	36.00	36.00	Pass
11b	1Mbps	1	6	2437	17.02	19.32		30.00	30.00	4.40	4.68	21.42	24.00	36.00	36.00	Pass
11b	1Mbps	1	11	2462	17.45	19.25		30.00	30.00	4.40	4.68	21.85	23.93	36.00	36.00	Pass
11b	1Mbps	1	12	2467	17.30	17.82		30.00	30.00	4.40	4.68	21.70	22.50	36.00	36.00	Pass
11b	1Mbps	1	13	2472	14.17	13.95		30.00	30.00	4.40	4.68	18.57	18.63	36.00	36.00	Pass
11g	6Mbps	1	1	2412	21.41	21.76		30.00	30.00	4.40	4.68	25.81	26.44	36.00	36.00	Pass
11g	6Mbps	1	6	2437	22.21	21.93		30.00	30.00	4.40	4.68	26.61	26.61	36.00	36.00	Pass
11g	6Mbps	1	11	2462	22.03	21.90		30.00	30.00	4.40	4.68	26.43	26.58	36.00	36.00	Pass
11g	6Mbps	1	12	2467	22.11	21.70		30.00	30.00	4.40	4.68	26.51	26.38	36.00	36.00	Pass
11g	6Mbps	1	13	2472	22.17	22.45		30.00	30.00	4.40	4.68	26.57	27.13	36.00	36.00	Pass
HT20	MCS0	1	1	2412	20.16	21.93		30.00	30.00	4.40	4.68	24.56	26.61	36.00	36.00	Pass
HT20	MCS0	1	6	2437	22.59	21.70		30.00	30.00	4.40	4.68	26.99	26.38	36.00	36.00	Pass
HT20	MCS0	1	11	2462	22.50	21.79		30.00	30.00	4.40	4.68	26.90	26.47	36.00	36.00	Pass
HT20	MCS0	1	12	2467	21.66	21.93		30.00	30.00	4.40	4.68	26.06	26.61	36.00	36.00	Pass
HT20	MCS0	1	13	2472	22.30	22.85		30.00	30.00	4.40	4.68	26.70	27.53	36.00	36.00	Pass
11g	6Mbps	2	1	2412	19.41	19.88	22.66	30.00		4.68		27.34		36.00		Pass
11g	6Mbps	2	6	2437	22.25	22.85	25.57	30.00		4.68		30.25		36.00		Pass
11g	6Mbps	2	11	2462	20.43	21.45	23.98	30.00		4.68		28.66		36.00		Pass
11g	6Mbps	2	12	2467	18.30	18.75	21.54	30.00		4.68		26.22		36.00		Pass
11g	6Mbps	2	13	2472	17.16	17.25	20.22	30.00		4.68		24.90		36.00		Pass
HT20	MCS0	2	1	2412	18.47	18.48	21.49	30.00		4.68		26.17		36.00		Pass
HT20	MCS0	2	6	2437	22.82	22.75	25.80	30.00		4.68		30.48		36.00		Pass
HT20	MCS0	2	11	2462	20.75	21.20	23.99	30.00		4.68		28.67		36.00		Pass
HT20	MCS0	2	12	2467	18.99	19.25	22.13	30.00		4.68		26.81		36.00		Pass
HT20	MCS0	2	13	2472	17.20	17.80	20.52	30.00		4.68		25.20		36.00		Pass

Note: Measured power (dBm) has offset with cable loss.

TEST RESULTS DATA
Average Output Power

2.4GHz Band									
Mod.	Data Rate	N _{TX}	CH.	Freq. (MHz)	Duty Factor (dB)		Average Conducted Power (dBm)		
					Ant 1	Ant 2	Ant 1	Ant 2	SUM
11b	1Mbps	1	1	2412	0.06	0.06	16.76	17.46	
11b	1Mbps	1	6	2437	0.06	0.06	13.78	16.25	
11b	1Mbps	1	11	2462	0.06	0.06	14.29	16.31	
11b	1Mbps	1	12	2467	0.06	0.06	14.04	14.81	
11b	1Mbps	1	13	2472	0.06	0.06	10.86	10.90	
11g	6Mbps	1	1	2412	0.32	0.32	14.60	14.94	
11g	6Mbps	1	6	2437	0.32	0.32	15.47	14.97	
11g	6Mbps	1	11	2462	0.32	0.32	15.32	14.95	
11g	6Mbps	1	12	2467	0.32	0.32	15.41	14.93	
11g	6Mbps	1	13	2472	0.32	0.32	14.97	14.91	
HT20	MCS0	1	1	2412	0.34	0.31	13.24	14.83	
HT20	MCS0	1	6	2437	0.34	0.31	15.39	14.86	
HT20	MCS0	1	11	2462	0.34	0.31	15.41	14.81	
HT20	MCS0	1	12	2467	0.34	0.31	14.82	14.86	
HT20	MCS0	1	13	2472	0.34	0.31	14.49	14.90	
11g	6Mbps	2	1	2412	0.35	0.32	12.50	12.81	15.67
11g	6Mbps	2	6	2437	0.35	0.32	15.57	16.11	18.86
11g	6Mbps	2	11	2462	0.35	0.32	13.55	13.91	16.75
11g	6Mbps	2	12	2467	0.35	0.32	11.39	11.64	14.53
11g	6Mbps	2	13	2472	0.35	0.32	9.30	9.52	12.42
HT20	MCS0	2	1	2412	0.31	0.34	11.41	11.54	14.49
HT20	MCS0	2	6	2437	0.31	0.34	15.26	15.93	18.62
HT20	MCS0	2	11	2462	0.31	0.34	13.36	13.84	16.62
HT20	MCS0	2	12	2467	0.31	0.34	11.59	12.04	14.83
HT20	MCS0	2	13	2472	0.31	0.34	9.53	9.74	12.65

Note: Measured power (dBm) has offset with cable loss.

TEST RESULTS DATA
Peak Power Spectral Density

2.4GHz Band												
Mod.	Data Rate	N _{TX}	CH.	Freq. (MHz)	Peak PSD (dBm/3kHz)			DG (dBi)		Peak PSD Limit (dBm/3kHz)		Pass/Fail
					Ant 1	Ant 2	Worse + 3.01	Ant 1	Ant 2	Ant 1	Ant 2	
11b	1Mbps	1	1	2412	-6.31	-3.52	-	4.40	4.68	8.00	8.00	Pass
11b	1Mbps	1	6	2437	-8.55	-5.94		4.40	4.68	8.00	8.00	Pass
11b	1Mbps	1	11	2462	-7.59	-4.64		4.40	4.68	8.00	8.00	Pass
11b	1Mbps	1	12	2467	-7.94	-7.52		4.40	4.68	8.00	8.00	Pass
11b	1Mbps	1	13	2472	-11.77	-11.52		4.40	4.68	8.00	8.00	Pass
11g	6Mbps	1	1	2412	-9.92	-9.58		4.40	4.68	8.00	8.00	Pass
11g	6Mbps	1	6	2437	-10.42	-10.34		4.40	4.68	8.00	8.00	Pass
11g	6Mbps	1	11	2462	-9.41	-10.42		4.40	4.68	8.00	8.00	Pass
11g	6Mbps	1	12	2467	-9.43	-10.05		4.40	4.68	8.00	8.00	Pass
11g	6Mbps	1	13	2472	-9.23	-9.21		4.40	4.68	8.00	8.00	Pass
HT20	MCS0	1	1	2412	-12.52	-11.52		4.40	4.68	8.00	8.00	Pass
HT20	MCS0	1	6	2437	-10.05	-10.45		4.40	4.68	8.00	8.00	Pass
HT20	MCS0	1	11	2462	-10.69	-10.30		4.40	4.68	8.00	8.00	Pass
HT20	MCS0	1	12	2467	-10.48	-10.71		4.40	4.68	8.00	8.00	Pass
HT20	MCS0	1	13	2472	-10.42	-9.18		4.40	4.68	8.00	8.00	Pass
11g	6Mbps	2	1	2412	-13.23	-11.96	-8.95	7.55	6.45	Pass		
11g	6Mbps	2	6	2437	-10.25	-8.88	-5.87	7.55	6.45	Pass		
11g	6Mbps	2	11	2462	-11.52	-11.39	-8.38	7.55	6.45	Pass		
11g	6Mbps	2	12	2467	-14.41	-12.74	-9.73	7.55	6.45	Pass		
11g	6Mbps	2	13	2472	-14.89	-16.76	-11.88	7.55	6.45	Pass		
HT20	MCS0	2	1	2412	-14.53	-13.83	-10.82	7.55	6.45	Pass		
HT20	MCS0	2	6	2437	-10.19	-10.66	-7.18	7.55	6.45	Pass		
HT20	MCS0	2	11	2462	-12.15	-11.80	-8.79	7.55	6.45	Pass		
HT20	MCS0	2	12	2467	-14.38	-13.70	-10.69	7.55	6.45	Pass		
HT20	MCS0	2	13	2472	-15.41	-15.50	-12.40	7.55	6.45	Pass		

Measured power density (dBm) has offset with cable loss.



Appendix B. AC Conducted Emission Test Results

Test Engineer :	Marlowe Ho	Temperature :	23~25°C
		Relative Humidity :	50~53%

EUT Information

Report NO : 730732-01
 Test Mode : Mode 1
 Test Voltage : 120Vac/60Hz
 Phase : Line

ENV216 Auto Test FCC Power Bar - L

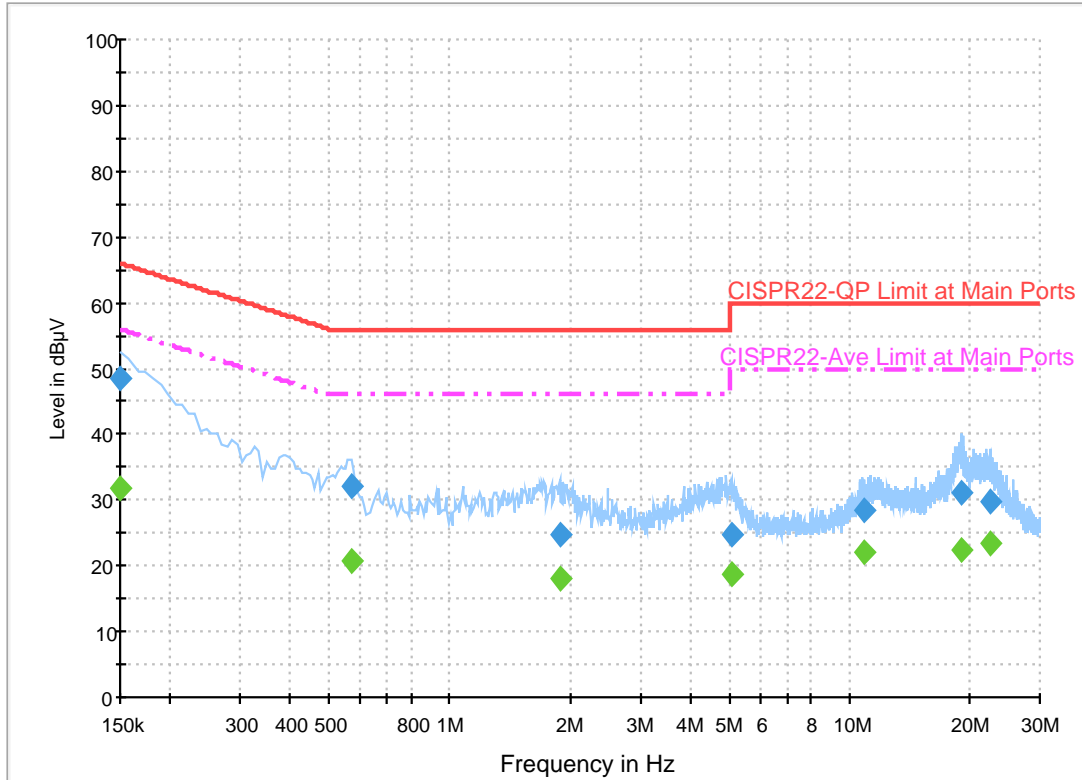

Final Result 1

Frequency (MHz)	QuasiPeak (dBµV)	Filter	Line	Corr. (dB)	Margin (dB)	Limit (dBµV)
0.150000	48.4	Off	L1	19.6	17.6	66.0
0.566000	32.1	Off	L1	19.6	23.9	56.0
1.886000	24.8	Off	L1	19.6	31.2	56.0
5.062000	24.7	Off	L1	19.8	35.3	60.0
10.854000	28.3	Off	L1	20.1	31.7	60.0
19.046000	31.0	Off	L1	20.6	29.0	60.0
22.430000	29.8	Off	L1	20.7	30.2	60.0

Final Result 2

Frequency (MHz)	Average (dBµV)	Filter	Line	Corr. (dB)	Margin (dB)	Limit (dBµV)
0.150000	31.7	Off	L1	19.6	24.3	56.0
0.566000	20.7	Off	L1	19.6	25.3	46.0
1.886000	17.9	Off	L1	19.6	28.1	46.0
5.062000	18.7	Off	L1	19.8	31.3	50.0
10.854000	21.9	Off	L1	20.1	28.1	50.0
19.046000	22.4	Off	L1	20.6	27.6	50.0
22.430000	23.4	Off	L1	20.7	26.6	50.0

EUT Information

Report NO : 730732-01
 Test Mode : Mode 1
 Test Voltage : 120Vac/60Hz
 Phase : Neutral

ENV216 Auto Test FCC Power Bar - N

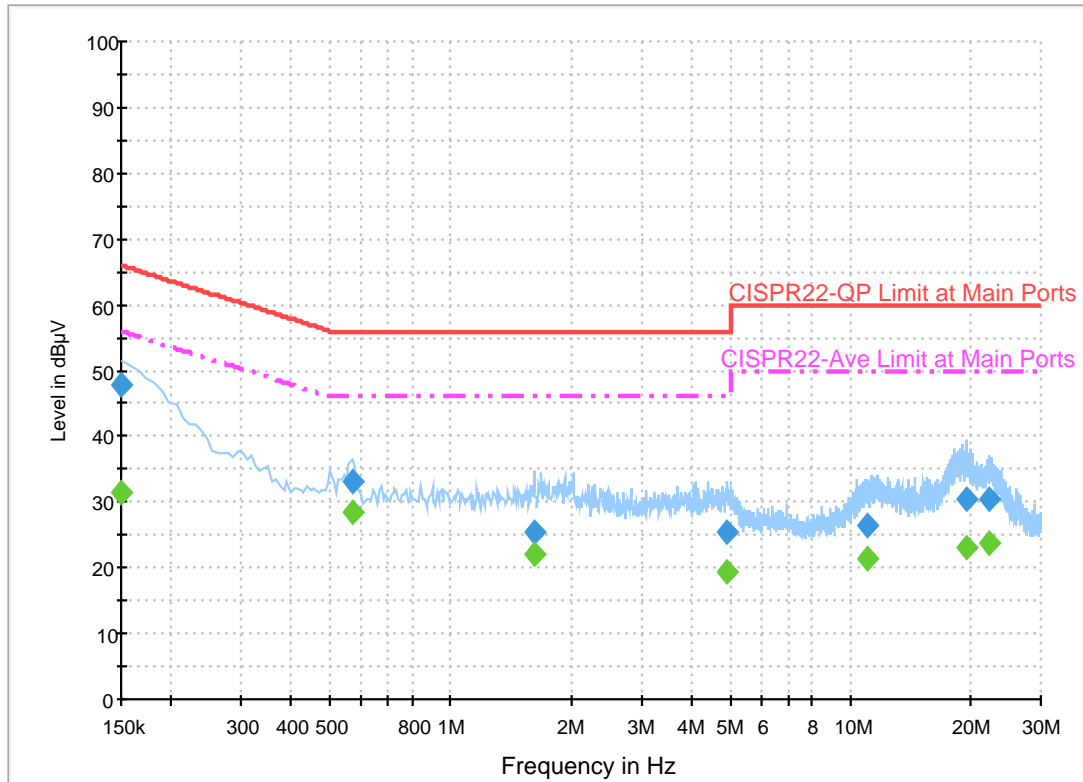

Final Result 1

Frequency (MHz)	QuasiPeak (dBµV)	Filter	Line	Corr. (dB)	Margin (dB)	Limit (dBµV)
0.150000	48.0	Off	N	19.5	18.0	66.0
0.566000	33.0	Off	N	19.5	23.0	56.0
1.622000	25.4	Off	N	19.6	30.6	56.0
4.910000	25.4	Off	N	19.7	30.6	56.0
10.998000	26.4	Off	N	20.1	33.6	60.0
19.558000	30.4	Off	N	20.7	29.6	60.0
22.334000	30.4	Off	N	20.8	29.6	60.0

Final Result 2

Frequency (MHz)	Average (dBµV)	Filter	Line	Corr. (dB)	Margin (dB)	Limit (dBµV)
0.150000	31.5	Off	N	19.5	24.5	56.0
0.566000	28.5	Off	N	19.5	17.5	46.0
1.622000	22.1	Off	N	19.6	23.9	46.0
4.910000	19.3	Off	N	19.7	26.7	46.0
10.998000	21.3	Off	N	20.1	28.7	50.0
19.558000	23.1	Off	N	20.7	26.9	50.0
22.334000	23.6	Off	N	20.8	26.4	50.0



Appendix C. Radiated Spurious Emission

Test Engineer :	Nick Yu and Peter Chiu	Temperature :	22~26°C
		Relative Humidity :	56~62%

2.4GHz 2400~2483.5MHz

WIFI 802.11b (Band Edge @ 3m)

WIFI	Note	Frequency	Level	Over	Limit	Read	Antenna	Cable	Preamp	Ant	Table	Peak	Pol.
Ant.				Limit	Line	Level	Factor	Loss	Factor	Pos	Pos	Avg.	
1		(MHz)	(dBμV/m)	(dB)	(dBμV/m)	(dBμV)	(dB/m)	(dB)	(dB)	(cm)	(deg)	(P/A)	(H/V)
802.11b CH 01 2412MHz		2386.755	57.3	-16.7	74	47.67	27.06	4.03	31.49	100	336	P	H
		2387.28	49.38	-4.62	54	39.75	27.06	4.03	31.49	100	336	A	H
	*	2412	110.03	-	-	100.3	27.14	4.05	31.49	100	336	P	H
	*	2412	105.71	-	-	95.98	27.14	4.05	31.49	100	336	A	H
		2386.755	56.18	-17.82	74	46.55	27.06	4.03	31.49	390	236	P	V
		2387.175	46.58	-7.42	54	36.95	27.06	4.03	31.49	390	236	A	V
	*	2412	108.01	-	-	98.28	27.14	4.05	31.49	390	236	P	V
	*	2412	103.66	-	-	93.93	27.14	4.05	31.49	390	236	A	V
802.11b CH 06 2437MHz		2357.32	52.11	-21.89	74	42.6	26.97	4.01	31.5	174	318	P	H
		2389.38	40.24	-13.76	54	30.6	27.07	4.03	31.49	174	318	A	H
	*	2437	106.16	-	-	96.33	27.21	4.07	31.48	174	318	P	H
	*	2437	101.85	-	-	92.02	27.21	4.07	31.48	174	318	A	H
		2492.23	53.06	-20.94	74	43	27.38	4.11	31.46	174	318	P	H
		2485.37	41.01	-12.99	54	30.98	27.36	4.11	31.47	174	318	A	H
		2315.18	51.81	-22.19	74	42.47	26.85	3.97	31.51	380	284	P	V
		2389.38	39.59	-14.41	54	29.95	27.07	4.03	31.49	380	284	A	V
	*	2437	104.03	-	-	94.2	27.21	4.07	31.48	380	284	P	V
	*	2437	99.86	-	-	90.03	27.21	4.07	31.48	380	284	A	V
		2498.81	53.39	-20.61	74	43.31	27.4	4.11	31.46	380	284	P	V
		2489.57	40.23	-13.77	54	30.19	27.37	4.11	31.47	380	284	A	V



802.11b CH 11 2462MHz	*	2462	107.08	-	-	97.15	27.29	4.08	31.47	145	332	P	H
	*	2462	103.05	-	-	93.12	27.29	4.08	31.47	145	332	A	H
		2483.68	54.6	-19.4	74	44.58	27.35	4.11	31.47	145	332	P	H
		2483.52	45.36	-8.64	54	35.34	27.35	4.11	31.47	145	332	A	H
	*	2462	103.4	-	-	93.47	27.29	4.08	31.47	374	229	P	V
	*	2462	99.14	-	-	89.21	27.29	4.08	31.47	374	229	A	V
		2483.92	53.32	-20.68	74	43.3	27.35	4.11	31.47	374	229	P	V
		2483.52	42.86	-11.14	54	32.84	27.35	4.11	31.47	374	229	A	V
Remark	1. No other spurious found. 2. All results are PASS against Peak and Average limit line.												



WIFI Ant. 1	Note	Frequency (MHz)	Level (dBμV/m)	Over Limit (dB)	Limit Line (dBμV/m)	Read Level (dBμV)	Antenna Factor (dB/m)	Cable Loss (dB)	Preamp Factor (dB)	Ant Pos (cm)	Table Pos (deg)	Peak Avg. (P/A)	Pol. (H/V)
802.11b CH 12 2467MHz	*	2467	107.87	-	-	97.92	27.3	4.09	31.47	115	326	P	H
	*	2467	103.53	-	-	93.58	27.3	4.09	31.47	115	326	A	H
		2483.64	59.33	-14.67	74	49.31	27.35	4.11	31.47	115	326	P	H
		2484.16	50.81	-3.19	54	40.79	27.35	4.11	31.47	115	326	A	H
	*	2467	105.29	-	-	95.34	27.3	4.09	31.47	363	208	P	V
	*	2467	100.79	-	-	90.84	27.3	4.09	31.47	363	208	A	V
		2483.76	57.95	-16.05	74	47.93	27.35	4.11	31.47	363	208	P	V
		2484.04	49.32	-4.68	54	39.3	27.35	4.11	31.47	363	208	A	V
802.11b CH 13 2472MHz	*	2472	104.16	-	-	94.19	27.32	4.09	31.47	194	332	P	H
	*	2472	99.93	-	-	89.96	27.32	4.09	31.47	194	332	A	H
		2485.72	58.31	-15.69	74	48.28	27.36	4.11	31.47	194	332	P	H
		2486.72	50.28	-3.72	54	40.25	27.36	4.11	31.47	194	332	A	H
	*	2472	102.11	-	-	92.14	27.32	4.09	31.47	365	205	P	V
	*	2472	97.84	-	-	87.87	27.32	4.09	31.47	365	205	A	V
		2485.68	56.91	-17.09	74	46.88	27.36	4.11	31.47	365	205	P	V
		2485.76	48.49	-5.51	54	38.46	27.36	4.11	31.47	365	205	A	V
Remark	1. No other spurious found. 2. All results are PASS against Peak and Average limit line.												



2.4GHz 2400~2483.5MHz

WIFI 802.11b (Harmonic @ 3m)

WIFI Ant. 1	Note	Frequency (MHz)	Level (dBμV/m)	Over Limit (dB)	Limit Line (dBμV/m)	Read Level (dBμV)	Antenna Factor (dB/m)	Cable Loss (dB)	Preamp Factor (dB)	Ant Pos (cm)	Table Pos (deg)	Peak Avg. (P/A)	Pol. (H/V)
802.11b CH 01 2412MHz		4824	45.66	-28.34	74	65.09	32.18	6.17	58.31	100	0	P	H
		4824	42.9	-31.1	74	62.33	32.18	6.17	58.31	100	0	P	V
802.11b CH 06 2437MHz		4874	46.36	-27.64	74	65.6	32.27	6.21	58.24	100	0	P	H
		7311	57.74	-16.26	74	71.79	36.97	7.72	59.09	100	20	P	H
		7311	50.77	-3.23	54	64.82	36.97	7.72	59.09	100	20	A	H
		4874	43.02	-30.98	74	62.26	32.27	6.21	58.24	100	0	P	V
		7311	56.37	-17.63	74	70.42	36.97	7.72	59.09	383	119	P	V
		7311	49.25	-4.75	54	63.3	36.97	7.72	59.09	383	119	A	V
802.11b CH 11 2462MHz		4924	43.73	-30.27	74	62.82	32.36	6.23	58.18	100	0	P	H
		7386	56.62	-17.38	74	70.57	37.18	7.72	59.14	100	20	P	H
		7386	50.31	-3.69	54	64.26	37.18	7.72	59.14	100	20	A	H
		4924	41.94	-32.06	74	61.03	32.36	6.23	58.18	100	0	P	V
		7386	55.44	-18.56	74	69.39	37.18	7.72	59.14	389	117	P	V
			7386	48.55	-5.45	54	62.5	37.18	7.72	59.14	389	117	A
Remark	1. No other spurious found. 2. All results are PASS against Peak and Average limit line.												



WIFI Ant. 1	Note	Frequency (MHz)	Level (dBμV/m)	Over Limit (dB)	Limit Line (dBμV/m)	Read Level (dBμV)	Antenna Factor (dB/m)	Cable Loss (dB)	Preamp Factor (dB)	Ant Pos (cm)	Table Pos (deg)	Peak Avg. (P/A)	Pol. (H/V)
802.11b CH 12 2467MHz		4934	45.56	-28.44	74	64.62	32.38	6.24	58.18	100	0	P	H
		7401	57.34	-16.66	74	71.27	37.22	7.72	59.15	119	20	P	H
		7401	50.97	-3.03	54	64.9	37.22	7.72	59.15	119	20	A	H
		4934	42.06	-31.94	74	61.12	32.38	6.24	58.18	100	0	P	V
		7401	56.03	-17.97	74	69.96	37.22	7.72	59.15	382	116	P	V
		7401	49.17	-4.83	54	63.1	37.22	7.72	59.15	382	116	A	V
802.11b CH 13 2472MHz		4944	43.28	-30.72	74	62.31	32.4	6.24	58.16	100	0	P	H
		7416	48.38	-25.62	74	62.24	37.26	7.74	59.15	100	0	P	H
		4944	41	-33	74	60.03	32.4	6.24	58.16	100	0	P	V
		7416	46.86	-27.14	74	60.72	37.26	7.74	59.15	100	0	P	V
Remark	1. No other spurious found. 2. All results are PASS against Peak and Average limit line.												



2.4GHz 2400~2483.5MHz

WIFI 802.11g (Band Edge @ 3m)

WIFI Ant. 1	Note	Frequency (MHz)	Level (dBμV/m)	Over Limit (dB)	Limit Line (dBμV/m)	Read Level (dBμV)	Antenna Factor (dB/m)	Cable Loss (dB)	Preamp Factor (dB)	Ant Pos (cm)	Table Pos (deg)	Peak Avg. (P/A)	Pol. (H/V)
802.11g CH 01 2412MHz		2389.8	62.27	-11.73	74	52.63	27.07	4.03	31.49	124	329	P	H
		2390	50.08	-3.92	54	40.44	27.07	4.03	31.49	124	329	A	H
	*	2412	108.77	-	-	99.04	27.14	4.05	31.49	124	329	P	H
	*	2412	99.1	-	-	89.37	27.14	4.05	31.49	124	329	A	H
		2390	60.19	-13.81	74	50.55	27.07	4.03	31.49	387	234	P	V
		2390	48.14	-5.86	54	38.5	27.07	4.03	31.49	387	234	A	V
	*	2412	106.32	-	-	96.59	27.14	4.05	31.49	387	234	P	V
	*	2412	96.51	-	-	86.78	27.14	4.05	31.49	387	234	A	V
802.11g CH 06 2437MHz		2382.94	55.55	-18.45	74	45.93	27.05	4.03	31.49	145	331	P	H
		2389.94	44.99	-9.01	54	35.35	27.07	4.03	31.49	145	331	A	H
	*	2437	109.21	-	-	99.38	27.21	4.07	31.48	145	331	P	H
	*	2437	99.36	-	-	89.53	27.21	4.07	31.48	145	331	A	H
		2486.63	57.49	-16.51	74	47.46	27.36	4.11	31.47	145	331	P	H
		2485.37	46.31	-7.69	54	36.28	27.36	4.11	31.47	145	331	A	H
		2388.54	53.87	-20.13	74	44.23	27.07	4.03	31.49	374	222	P	V
		2387.14	42.89	-11.11	54	33.26	27.06	4.03	31.49	374	222	A	V
	*	2437	105.84	-	-	96.01	27.21	4.07	31.48	374	222	P	V
	*	2437	95.74	-	-	85.91	27.21	4.07	31.48	374	222	A	V
		2488.17	54.26	-19.74	74	44.23	27.36	4.11	31.47	374	222	P	V
		2487.82	43.62	-10.38	54	33.59	27.36	4.11	31.47	374	222	A	V



802.11g CH 11 2462MHz	*	2462	110.41	-	-	100.48	27.29	4.08	31.47	115	332	P	H
	*	2462	99.76	-	-	89.83	27.29	4.08	31.47	115	332	A	H
		2484.92	59.05	-14.95	74	49.03	27.35	4.11	31.47	115	332	P	H
		2483.56	47.28	-6.72	54	37.26	27.35	4.11	31.47	115	332	A	H
	*	2462	107.18	-	-	97.25	27.29	4.08	31.47	365	226	P	V
	*	2462	97.32	-	-	87.39	27.29	4.08	31.47	365	226	A	V
		2483.52	57.41	-16.59	74	47.39	27.35	4.11	31.47	365	226	P	V
		2483.52	46.15	-7.85	54	36.13	27.35	4.11	31.47	365	226	A	V
Remark	1. No other spurious found. 2. All results are PASS against Peak and Average limit line.												



WIFI Ant. 1	Note	Frequency (MHz)	Level (dBμV/m)	Over Limit (dB)	Limit Line (dBμV/m)	Read Level (dBμV)	Antenna Factor (dB/m)	Cable Loss (dB)	Preamp Factor (dB)	Ant Pos (cm)	Table Pos (deg)	Peak Avg. (P/A)	Pol. (H/V)
802.11g CH 12 2467MHz	*	2467	109.95	-	-	100	27.3	4.09	31.47	117	337	P	H
	*	2467	99.79	-	-	89.84	27.3	4.09	31.47	117	337	A	H
		2483.76	61.04	-12.96	74	51.02	27.35	4.11	31.47	117	337	P	H
		2483.76	48.91	-5.09	54	38.89	27.35	4.11	31.47	117	337	A	H
	*	2467	107.87	-	-	97.92	27.3	4.09	31.47	366	226	P	V
	*	2467	97.47	-	-	87.52	27.3	4.09	31.47	366	226	A	V
		2483.68	59.66	-14.34	74	49.64	27.35	4.11	31.47	366	226	P	V
		2483.56	47.97	-6.03	54	37.95	27.35	4.11	31.47	366	226	A	V
802.11g CH 13 2472MHz	*	2472	109.3	-	-	99.33	27.32	4.09	31.47	114	334	P	H
	*	2472	99.64	-	-	89.67	27.32	4.09	31.47	114	334	A	H
		2487.36	62.98	-11.02	74	52.95	27.36	4.11	31.47	114	334	P	H
		2483.52	50.64	-3.36	54	40.62	27.35	4.11	31.47	114	334	A	H
	*	2472	107.21	-	-	97.24	27.32	4.09	31.47	366	225	P	V
	*	2472	97.34	-	-	87.37	27.32	4.09	31.47	366	225	A	V
		2486.84	60.74	-13.26	74	50.71	27.36	4.11	31.47	366	225	P	V
		2483.52	47.91	-6.09	54	37.89	27.35	4.11	31.47	366	225	A	V
Remark	1. No other spurious found. 2. All results are PASS against Peak and Average limit line.												



2.4GHz 2400~2483.5MHz

WIFI 802.11g (Harmonic @ 3m)

WIFI Ant. 1	Note	Frequency (MHz)	Level (dBμV/m)	Over Limit (dB)	Limit Line (dBμV/m)	Read Level (dBμV)	Antenna Factor (dB/m)	Cable Loss (dB)	Preamp Factor (dB)	Ant Pos (cm)	Table Pos (deg)	Peak Avg. (P/A)	Pol. (H/V)
802.11g CH 01 2412MHz		4824	43.46	-30.54	74	62.89	32.18	6.17	58.31	100	0	P	H
		4824	41.39	-32.61	74	60.82	32.18	6.17	58.31	100	0	P	V
802.11g CH 06 2437MHz		4874	43.24	-30.76	74	62.48	32.27	6.21	58.24	100	0	P	H
		7311	58.85	-15.15	74	72.9	36.97	7.72	59.09	109	13	P	H
		7311	43.38	-10.62	54	57.43	36.97	7.72	59.09	109	13	A	H
		4874	40.61	-33.39	74	59.85	32.27	6.21	58.24	100	0	P	V
		7311	49.35	-24.65	74	63.4	36.97	7.72	59.09	100	0	P	V
802.11g CH 11 2462MHz		4924	42.39	-31.61	74	61.48	32.36	6.23	58.18	100	0	P	H
		7386	58.41	-15.59	74	72.36	37.18	7.72	59.14	102	12	P	H
		7386	42.46	-11.54	54	56.41	37.18	7.72	59.14	102	12	A	H
		4924	41.48	-32.52	74	60.57	32.36	6.23	58.18	100	0	P	V
		7386	56.1	-17.9	74	70.05	37.18	7.72	59.14	400	92	P	V
		7386	40.36	-13.64	54	54.31	37.18	7.72	59.14	400	92	A	V
Remark	<ol style="list-style-type: none"> No other spurious found. All results are PASS against Peak and Average limit line. 												



WIFI Ant. 1	Note	Frequency (MHz)	Level (dBμV/m)	Over Limit (dB)	Limit Line (dBμV/m)	Read Level (dBμV)	Antenna Factor (dB/m)	Cable Loss (dB)	Preamp Factor (dB)	Ant Pos (cm)	Table Pos (deg)	Peak Avg. (P/A)	Pol. (H/V)
802.11g CH 12 2467MHz		4934	43.53	-30.47	74	62.59	32.38	6.24	58.18	100	0	P	H
		7401	57.82	-16.18	74	71.75	37.22	7.72	59.15	101	12	P	H
		7401	42.57	-11.43	54	56.5	37.22	7.72	59.15	101	12	A	H
		4934	40.84	-33.16	74	59.9	32.38	6.24	58.18	100	0	P	V
		7401	56.33	-17.67	74	70.26	37.22	7.72	59.15	400	93	P	V
		7401	40.62	-13.38	54	54.55	37.22	7.72	59.15	400	93	A	V
802.11g CH 13 2472MHz		4944	42.97	-31.03	74	62	32.4	6.24	58.16	100	0	P	H
		7416	58.43	-15.57	74	72.29	37.26	7.74	59.15	108	13	P	H
		7416	43.09	-10.91	54	56.95	37.26	7.74	59.15	108	13	A	H
		4944	41.66	-32.34	74	60.69	32.4	6.24	58.16	100	0	P	V
		7416	56.19	-17.81	74	70.05	37.26	7.74	59.15	397	90	P	V
		7416	41.1	-12.9	54	54.96	37.26	7.74	59.15	397	90	A	V
Remark	<ol style="list-style-type: none"> No other spurious found. All results are PASS against Peak and Average limit line. 												



2.4GHz 2400~2483.5MHz

WIFI 802.11n HT20 (Band Edge @ 3m)

WIFI Ant. 1	Note	Frequency (MHz)	Level (dBμV/m)	Over Limit (dB)	Limit Line (dBμV/m)	Read Level (dBμV)	Antenna Factor (dB/m)	Cable Loss (dB)	Preamp Factor (dB)	Ant Pos (cm)	Table Pos (deg)	Peak Avg. (P/A)	Pol. (H/V)
802.11n HT20 CH 01 2412MHz		2389.485	63.4	-10.6	74	53.76	27.07	4.03	31.49	124	326	P	H
		2389.905	50.8	-3.2	54	41.16	27.07	4.03	31.49	124	326	A	H
	*	2412	107.75	-	-	98.02	27.14	4.05	31.49	124	326	P	H
	*	2412	97.74	-	-	88.01	27.14	4.05	31.49	124	326	A	H
		2388.75	61.86	-12.14	74	52.22	27.07	4.03	31.49	388	234	P	V
		2389.905	47.73	-6.27	54	38.09	27.07	4.03	31.49	388	234	A	V
	*	2412	105.4	-	-	95.67	27.14	4.05	31.49	388	234	P	V
	*	2412	94.8	-	-	85.07	27.14	4.05	31.49	388	234	A	V
802.11n HT20 CH 06 2437MHz		2377.9	55.09	-18.91	74	45.49	27.03	4.03	31.49	146	326	P	H
		2388.68	45.12	-8.88	54	35.48	27.07	4.03	31.49	146	326	A	H
	*	2437	109.74	-	-	99.91	27.21	4.07	31.48	146	326	P	H
	*	2437	99.44	-	-	89.61	27.21	4.07	31.48	146	326	A	H
		2488.31	56.4	-17.6	74	46.37	27.36	4.11	31.47	146	326	P	H
		2484.67	45.76	-8.24	54	35.74	27.35	4.11	31.47	146	326	A	H
		2375.52	54.18	-19.82	74	44.58	27.03	4.03	31.49	375	229	P	V
		2389.94	42.54	-11.46	54	32.9	27.07	4.03	31.49	375	229	A	V
	*	2437	105.92	-	-	96.09	27.21	4.07	31.48	375	229	P	V
	*	2437	95.85	-	-	86.02	27.21	4.07	31.48	375	229	A	V
		2495.8	54.24	-19.76	74	44.17	27.39	4.11	31.46	375	229	P	V
	2484.18	43.28	-10.72	54	33.26	27.35	4.11	31.47	375	229	A	V	



802.11n HT20 CH 11 2462MHz	*	2462	109.71	-	-	99.78	27.29	4.08	31.47	112	328	P	H
	*	2462	99.83	-	-	89.9	27.29	4.08	31.47	112	328	A	H
		2483.56	60.56	-13.44	74	50.54	27.35	4.11	31.47	112	328	P	H
		2483.6	47.91	-6.09	54	37.89	27.35	4.11	31.47	112	328	A	H
	*	2462	107.61	-	-	97.68	27.29	4.08	31.47	365	208	P	V
	*	2462	97.05	-	-	87.12	27.29	4.08	31.47	365	208	A	V
		2485.04	58.73	-15.27	74	48.7	27.36	4.11	31.47	365	208	P	V
		2483.92	46.52	-7.48	54	36.5	27.35	4.11	31.47	365	208	A	V
Remark	1. No other spurious found. 2. All results are PASS against Peak and Average limit line.												



WiFi Ant. 1	Note	Frequency (MHz)	Level (dBμV/m)	Over Limit (dB)	Limit Line (dBμV/m)	Read Level (dBμV)	Antenna Factor (dB/m)	Cable Loss (dB)	Preamp Factor (dB)	Ant Pos (cm)	Table Pos (deg)	Peak Avg. (P/A)	Pol. (H/V)
802.11n HT20 CH 12 2467MHz	*	2467	110.15	-	-	100.2	27.3	4.09	31.47	118	327	P	H
	*	2467	100.17	-	-	90.22	27.3	4.09	31.47	118	327	A	H
		2484.88	61.27	-12.73	74	51.25	27.35	4.11	31.47	118	327	P	H
		2483.6	49.48	-4.52	54	39.46	27.35	4.11	31.47	118	327	A	H
	*	2467	106.51	-	-	96.56	27.3	4.09	31.47	365	226	P	V
	*	2467	96.55	-	-	86.6	27.3	4.09	31.47	365	226	A	V
		2483.8	58.41	-15.59	74	48.39	27.35	4.11	31.47	365	226	P	V
		2484.16	47.6	-6.4	54	37.58	27.35	4.11	31.47	365	226	A	V
802.11n HT20 CH 13 2472MHz	*	2472	108.89	-	-	98.92	27.32	4.09	31.47	116	327	P	H
	*	2472	99.09	-	-	89.12	27.32	4.09	31.47	116	327	A	H
		2485.08	61.99	-12.01	74	51.96	27.36	4.11	31.47	116	327	P	H
		2483.68	49.97	-4.03	54	39.95	27.35	4.11	31.47	116	327	A	H
	*	2472	105.72	-	-	95.75	27.32	4.09	31.47	366	208	P	V
	*	2472	96.05	-	-	86.08	27.32	4.09	31.47	366	208	A	V
			2483.6	62.88	-11.12	74	52.86	27.35	4.11	31.47	366	208	P
		2484.08	48.06	-5.94	54	38.04	27.35	4.11	31.47	366	208	A	V
Remark	1. No other spurious found. 2. All results are PASS against Peak and Average limit line.												



2.4GHz 2400~2483.5MHz

WIFI 802.11n HT20 (Harmonic @ 3m)

WIFI Ant. 1	Note	Frequency (MHz)	Level (dBμV/m)	Over Limit (dB)	Limit Line (dBμV/m)	Read Level (dBμV)	Antenna Factor (dB/m)	Cable Loss (dB)	Preamp Factor (dB)	Ant Pos (cm)	Table Pos (deg)	Peak Avg. (P/A)	Pol. (H/V)
802.11n HT20 CH 01 2412MHz		4824	41.34	-32.66	74	60.77	32.18	6.17	58.31	100	0	P	H
		4824	40.48	-33.52	74	59.91	32.18	6.17	58.31	100	0	P	V
802.11n HT20 CH 06 2437MHz		4874	44.48	-29.52	74	63.72	32.27	6.21	58.24	100	0	P	H
		7311	58.02	-15.98	74	72.07	36.97	7.72	59.09	111	13	P	H
		7311	43.13	-10.87	54	57.18	36.97	7.72	59.09	111	13	A	H
		4874	41.37	-32.63	74	60.61	32.27	6.21	58.24	100	0	P	V
		7311	49.73	-24.27	74	63.78	36.97	7.72	59.09	100	0	P	V
802.11n HT20 CH 11 2462MHz		4924	43.11	-30.89	74	62.2	32.36	6.23	58.18	100	0	P	H
		7386	56.28	-17.72	74	70.23	37.18	7.72	59.14	100	13	P	H
		7386	41.9	-12.1	54	55.85	37.18	7.72	59.14	100	13	A	H
		4924	41.48	-32.52	74	60.57	32.36	6.23	58.18	100	0	P	V
		7386	55.01	-18.99	74	68.96	37.18	7.72	59.14	400	93	P	V
		7386	40.2	-13.8	54	54.15	37.18	7.72	59.14	400	93	A	V
Remark	1. No other spurious found. 2. All results are PASS against Peak and Average limit line.												



WIFI Ant. 1	Note	Frequency (MHz)	Level (dBμV/m)	Over Limit (dB)	Limit Line (dBμV/m)	Read Level (dBμV)	Antenna Factor (dB/m)	Cable Loss (dB)	Preamp Factor (dB)	Ant Pos (cm)	Table Pos (deg)	Peak Avg. (P/A)	Pol. (H/V)
802.11n HT20 CH 12 2467MHz		4934	42.64	-31.36	74	61.7	32.38	6.24	58.18	100	0	P	H
		7401	56.85	-17.15	74	70.78	37.22	7.72	59.15	101	12	P	H
		7401	41.91	-12.09	54	55.84	37.22	7.72	59.15	101	12	A	H
		4934	41.86	-32.14	74	60.92	32.38	6.24	58.18	100	0	P	V
		7401	49.56	-24.44	74	63.49	37.22	7.72	59.15	100	0	P	V
802.11n HT20 CH 13 2472MHz		4944	42.49	-31.51	74	61.52	32.4	6.24	58.16	100	0	P	H
		7416	59.23	-14.77	74	73.09	37.26	7.74	59.15	100	179	P	H
		7416	43.45	-10.55	54	57.31	37.26	7.74	59.15	100	179	A	H
		4944	40.71	-33.29	74	59.74	32.4	6.24	58.16	100	0	P	V
		7416	49.32	-24.68	74	63.18	37.26	7.74	59.15	100	0	P	V
Remark	1. No other spurious found. 2. All results are PASS against Peak and Average limit line.												



Emission below 1GHz

2.4GHz WIFI 802.11b (LF)

WIFI	Note	Frequency	Level	Over	Limit	Read	Antenna	Cable	Preamp	Ant	Table	Peak	Pol.
Ant.				Limit	Line	Level	Factor	Loss	Factor	Pos	Pos	Avg.	
1		(MHz)	(dBμV/m)	(dB)	(dBμV/m)	(dBμV)	(dB/m)	(dB)	(dB)	(cm)	(deg)	(P/A)	(H/V)
2.4GHz 802.11b LF		160.14	31.64	-11.86	43.5	46.19	16.7	1.02	32.43	-	-	P	H
		184.17	34.2	-9.3	43.5	50.29	15.01	1.14	32.4	-	-	P	H
		219.27	34.67	-11.33	46	50.4	15.29	1.23	32.39	-	-	P	H
		624.8	34.62	-11.38	46	38.57	26.41	2	32.46	-	-	P	H
		746.6	38.82	-7.18	46	40.69	28.16	2.21	32.34	100	0	P	H
		976.9	32.55	-21.45	54	29.66	31.08	2.53	30.95	-	-	P	H
		75.63	33.04	-6.96	40	51.95	12.76	0.76	32.48	100	0	P	V
		112.62	29.85	-13.65	43.5	44.3	17.09	0.89	32.47	-	-	P	V
		219.27	29.13	-16.87	46	44.86	15.29	1.23	32.39	-	-	P	V
		623.4	32.92	-13.08	46	36.89	26.39	2	32.46	-	-	P	V
		745.9	38.94	-7.06	46	40.82	28.15	2.21	32.34	-	-	P	V
	897.1	33.1	-12.9	46	32.95	29.24	2.42	31.68	-	-	P	V	
Remark	1. No other spurious found. 2. All results are PASS against limit line.												



2.4GHz 2400~2483.5MHz

WIFI 802.11b (Band Edge @ 3m)

WIFI	Note	Frequency	Level	Over	Limit	Read	Antenna	Cable	Preamp	Ant	Table	Peak	Pol.
Ant.				Limit	Line	Level	Factor	Loss	Factor	Pos	Pos	Avg.	
2		(MHz)	(dBμV/m)	(dB)	(dBμV/m)	(dBμV)	(dB/m)	(dB)	(dB)	(cm)	(deg)	(P/A)	(H/V)
802.11b CH 01 2412MHz		2387.175	57.54	-16.46	74	47.91	27.06	4.03	31.49	100	176	P	H
		2387.175	50.16	-3.84	54	40.53	27.06	4.03	31.49	100	176	A	H
	*	2412	110.81	-	-	101.08	27.14	4.05	31.49	100	176	P	H
	*	2412	106.11	-	-	96.38	27.14	4.05	31.49	100	176	A	H
		2389.8	58.36	-15.64	74	48.72	27.07	4.03	31.49	301	262	P	V
		2387.175	50.17	-3.83	54	40.54	27.06	4.03	31.49	301	262	A	V
	*	2412	110.13	-	-	100.4	27.14	4.05	31.49	301	262	P	V
	*	2412	105.69	-	-	95.96	27.14	4.05	31.49	301	262	A	V
802.11b CH 06 2437MHz		2358.86	52.94	-21.06	74	43.42	26.98	4.01	31.5	308	22	P	H
		2356.06	42.02	-11.98	54	32.52	26.97	4	31.5	308	22	A	H
	*	2437	106.39	-	-	96.56	27.21	4.07	31.48	308	22	P	H
	*	2437	102.14	-	-	92.31	27.21	4.07	31.48	308	22	A	H
		2488.1	52.62	-21.38	74	42.59	27.36	4.11	31.47	308	22	P	H
		2489.78	40.64	-13.36	54	30.6	27.37	4.11	31.47	308	22	A	H
		2358.3	55.18	-18.82	74	45.67	26.97	4.01	31.5	237	279	P	V
		2357.88	46.03	-7.97	54	36.52	26.97	4.01	31.5	237	279	A	V
	*	2437	110.08	-	-	100.25	27.21	4.07	31.48	237	279	P	V
	*	2437	105.86	-	-	96.03	27.21	4.07	31.48	237	279	A	V
		2492.93	54.01	-19.99	74	43.95	27.38	4.11	31.46	237	279	P	V
		2484.25	41.7	-12.3	54	31.68	27.35	4.11	31.47	237	279	A	V



802.11b CH 11 2462MHz	*	2462	106.94	-	-	97.01	27.29	4.08	31.47	304	23	P	H
	*	2462	102.72	-	-	92.79	27.29	4.08	31.47	304	23	A	H
		2484.56	56.23	-17.77	74	46.21	27.35	4.11	31.47	304	23	P	H
		2483.52	47.53	-6.47	54	37.51	27.35	4.11	31.47	304	23	A	H
	*	2462	110	-	-	100.07	27.29	4.08	31.47	276	279	P	V
	*	2462	105.85	-	-	95.92	27.29	4.08	31.47	276	279	A	V
		2484.24	60.69	-13.31	74	50.67	27.35	4.11	31.47	276	279	P	V
		2483.52	49.81	-4.19	54	39.79	27.35	4.11	31.47	276	279	A	V
Remark	1. No other spurious found. 2. All results are PASS against Peak and Average limit line.												



WIFI Ant. 2	Note	Frequency (MHz)	Level (dBμV/m)	Over Limit (dB)	Limit Line (dBμV/m)	Read Level (dBμV)	Antenna Factor (dB/m)	Cable Loss (dB)	Preamp Factor (dB)	Ant Pos (cm)	Table Pos (deg)	Peak Avg. (P/A)	Pol. (H/V)
802.11b CH 12 2467MHz	*	2467	105.4	-	-	95.45	27.3	4.09	31.47	302	22	P	H
	*	2467	101.06	-	-	91.11	27.3	4.09	31.47	302	22	A	H
		2483.84	58.69	-15.31	74	48.67	27.35	4.11	31.47	302	22	P	H
		2484.12	48.79	-5.21	54	38.77	27.35	4.11	31.47	302	22	A	H
	*	2467	108.5	-	-	98.55	27.3	4.09	31.47	263	280	P	V
	*	2467	104.27	-	-	94.32	27.3	4.09	31.47	263	280	A	V
		2486.24	59.98	-14.02	74	49.95	27.36	4.11	31.47	263	280	P	V
		2484.16	50.29	-3.71	54	40.27	27.35	4.11	31.47	263	280	A	V
802.11b CH 13 2472MHz	*	2472	101.71	-	-	91.74	27.32	4.09	31.47	301	24	P	H
	*	2472	97.22	-	-	87.25	27.32	4.09	31.47	301	24	A	H
		2483.56	58.34	-15.66	74	48.32	27.35	4.11	31.47	301	24	P	H
		2485.72	47.49	-6.51	54	37.46	27.36	4.11	31.47	301	24	A	H
	*	2472	105.04	-	-	95.07	27.32	4.09	31.47	279	280	P	V
	*	2472	100.83	-	-	90.86	27.32	4.09	31.47	279	280	A	V
		2484.4	60.2	-13.8	74	50.18	27.35	4.11	31.47	279	280	P	V
		2484.76	49.81	-4.19	54	39.79	27.35	4.11	31.47	279	280	A	V
Remark	1. No other spurious found. 2. All results are PASS against Peak and Average limit line.												



2.4GHz 2400~2483.5MHz

WIFI 802.11b (Harmonic @ 3m)

WIFI Ant. 2	Note	Frequency (MHz)	Level (dBμV/m)	Over Limit (dB)	Limit Line (dBμV/m)	Read Level (dBμV)	Antenna Factor (dB/m)	Cable Loss (dB)	Preamp Factor (dB)	Ant Pos (cm)	Table Pos (deg)	Peak Avg. (P/A)	Pol. (H/V)
802.11b CH 01 2412MHz		2252	54.79	-19.21	74	45.72	26.66	3.92	31.53	100	168	P	H
		2252	43.13	-10.87	54	34.06	26.66	3.92	31.53	100	168	A	H
		2492	57.94	-16.06	74	47.88	27.38	4.11	31.46	100	176	P	H
		2492	45.6	-8.4	54	35.54	27.38	4.11	31.46	100	176	A	H
		4824	39.86	-34.14	74	59.29	32.18	6.17	58.31	100	0	P	H
		2252	55.56	-18.44	74	46.49	26.66	3.92	31.53	299	267	P	V
		2252	43.24	-10.76	54	34.17	26.66	3.92	31.53	299	267	A	V
		2492	58.59	-15.41	74	48.53	27.38	4.11	31.46	301	262	P	V
		2492	46.18	-7.82	54	36.12	27.38	4.11	31.46	301	262	A	V
		4824	40.61	-33.39	74	60.04	32.18	6.17	58.31	100	0	P	V
802.11b CH 06 2437MHz		2280	52.8	-21.2	74	43.62	26.74	3.94	31.52	308	22	P	H
		2280	39.82	-14.18	54	30.64	26.74	3.94	31.52	308	22	A	H
		4874	41.46	-32.54	74	60.7	32.27	6.21	58.24	100	0	P	H
		7311	49.39	-24.61	74	63.44	36.97	7.72	59.09	100	0	P	H
		2280	53.97	-20.03	74	44.79	26.74	3.94	31.52	237	279	P	V
		2280	41.46	-12.54	54	32.28	26.74	3.94	31.52	237	279	A	V
		4874	41.69	-32.31	74	60.93	32.27	6.21	58.24	100	0	P	V
		7311	56.67	-17.33	74	70.72	36.97	7.72	59.09	231	259	P	V
	7311	50.4	-3.6	54	64.45	36.97	7.72	59.09	231	259	A	V	



802.11b CH 11 2462MHz		2300	54.75	-19.25	74	45.5	26.8	3.95	31.52	304	23	P	H
		2300	42.02	-11.98	54	32.77	26.8	3.95	31.52	304	23	A	H
		2384	56.99	-17.01	74	47.37	27.05	4.03	31.49	317	25	P	H
		2384	45.81	-8.19	54	36.19	27.05	4.03	31.49	317	25	A	H
		4924	40.46	-33.54	74	59.55	32.36	6.23	58.18	100	0	P	H
		7386	49.48	-24.52	74	63.43	37.18	7.72	59.14	100	0	P	H
		2300	55.29	-18.71	74	46.04	26.8	3.95	31.52	276	279	P	V
		2300	44.47	-9.53	54	35.22	26.8	3.95	31.52	276	279	A	V
		2384	60.03	-13.97	74	50.41	27.05	4.03	31.49	281	267	P	V
		2384	49.82	-4.18	54	40.2	27.05	4.03	31.49	281	267	A	V
		4924	42.03	-31.97	74	61.12	32.36	6.23	58.18	100	0	P	V
		7386	56.58	-17.42	74	70.53	37.18	7.72	59.14	226	260	P	V
		7386	50.22	-3.78	54	64.17	37.18	7.72	59.14	226	260	A	V
Remark	1. No other spurious found. 2. All results are PASS against Peak and Average limit line.												



WIFI Ant. 2	Note	Frequency (MHz)	Level (dBμV/m)	Over Limit (dB)	Limit Line (dBμV/m)	Read Level (dBμV)	Antenna Factor (dB/m)	Cable Loss (dB)	Preamp Factor (dB)	Ant Pos (cm)	Table Pos (deg)	Peak Avg. (P/A)	Pol. (H/V)
802.11b CH 12 2467MHz		2310	55.24	-18.76	74	45.93	26.83	3.97	31.52	298	31	P	H
		2310	42.7	-11.3	54	33.39	26.83	3.97	31.52	298	31	A	H
		2384	54.63	-19.37	74	45.01	27.05	4.03	31.49	302	22	P	H
		2384	42.19	-11.81	54	32.57	27.05	4.03	31.49	302	22	A	H
		4934	38.91	-35.09	74	57.97	32.38	6.24	58.18	100	0	P	H
		7401	46.86	-27.14	74	60.79	37.22	7.72	59.15	100	0	P	H
		2310	56.92	-17.08	74	47.61	26.83	3.97	31.52	249	288	P	V
		2310	46.69	-7.31	54	37.38	26.83	3.97	31.52	249	288	A	V
		2388	58.11	-15.89	74	48.48	27.06	4.03	31.49	263	280	P	V
		2388	48.05	-5.95	54	38.42	27.06	4.03	31.49	263	280	A	V
		4934	40.34	-33.66	74	59.4	32.38	6.24	58.18	100	0	P	V
		7401	54.84	-19.16	74	68.77	37.22	7.72	59.15	225	261	P	V
		7401	48.49	-5.51	54	62.42	37.22	7.72	59.15	225	261	A	V
	802.11b CH 13 2472MHz		2314	55.14	-18.86	74	45.81	26.84	3.97	31.51	320	19	P
		2314	42.09	-11.91	54	32.76	26.84	3.97	31.51	320	19	A	H
		2390	53.68	-20.32	74	44.04	27.07	4.03	31.49	301	24	P	H
		2390	40.75	-13.25	54	31.11	27.07	4.03	31.49	301	24	A	H
		4944	40.36	-33.64	74	59.39	32.4	6.24	58.16	100	0	P	H
		7416	44.68	-29.32	74	58.54	37.26	7.74	59.15	100	0	P	H
		2314	55.35	-18.65	74	46.02	26.84	3.97	31.51	261	274	P	V
		2314	43.52	-10.48	54	34.19	26.84	3.97	31.51	261	274	A	V
		2390	56.31	-17.69	74	46.67	27.07	4.03	31.49	279	280	P	V
		2390	44.09	-9.91	54	34.45	27.07	4.03	31.49	279	280	A	V
		4944	39.8	-34.2	74	58.83	32.4	6.24	58.16	100	0	P	V
	7416	46.86	-27.14	74	60.72	37.26	7.74	59.15	100	0	P	V	
Remark	1. No other spurious found. 2. All results are PASS against Peak and Average limit line.												



2.4GHz 2400~2483.5MHz

WIFI 802.11g (Band Edge @ 3m)

WIFI Ant. 2	Note	Frequency (MHz)	Level (dBμV/m)	Over Limit (dB)	Limit Line (dBμV/m)	Read Level (dBμV)	Antenna Factor (dB/m)	Cable Loss (dB)	Preamp Factor (dB)	Ant Pos (cm)	Table Pos (deg)	Peak Avg. (P/A)	Pol. (H/V)
802.11g CH 01 2412MHz		2390	57.96	-16.04	74	48.32	27.07	4.03	31.49	102	177	P	H
		2389.695	47.48	-6.52	54	37.84	27.07	4.03	31.49	102	177	A	H
	*	2412	108.37	-	-	98.64	27.14	4.05	31.49	102	177	P	H
	*	2412	98.06	-	-	88.33	27.14	4.05	31.49	102	177	A	H
		2389.695	58.25	-15.75	74	48.61	27.07	4.03	31.49	178	243	P	V
		2390	47.33	-6.67	54	37.69	27.07	4.03	31.49	178	243	A	V
	*	2412	108.3	-	-	98.57	27.14	4.05	31.49	178	243	P	V
	*	2412	98.06	-	-	88.33	27.14	4.05	31.49	178	243	A	V
802.11g CH 06 2437MHz		2385.04	55.05	-18.95	74	45.42	27.06	4.03	31.49	306	44	P	H
		2389.94	43.92	-10.08	54	34.28	27.07	4.03	31.49	306	44	A	H
	*	2437	106.62	-	-	96.79	27.21	4.07	31.48	306	44	P	H
	*	2437	96.58	-	-	86.75	27.21	4.07	31.48	306	44	A	H
		2491.46	55.07	-18.93	74	45.03	27.37	4.11	31.47	306	44	P	H
		2487.4	44.34	-9.66	54	34.31	27.36	4.11	31.47	306	44	A	H
		2389.8	54.68	-19.32	74	45.04	27.07	4.03	31.49	165	254	P	V
		2388.96	44.2	-9.8	54	34.56	27.07	4.03	31.49	165	254	A	V
	*	2437	108.89	-	-	99.06	27.21	4.07	31.48	165	254	P	V
	*	2437	98.52	-	-	88.69	27.21	4.07	31.48	165	254	A	V
		2488.45	55.73	-18.27	74	45.69	27.37	4.11	31.47	165	254	P	V
		2484.81	45.03	-8.97	54	35.01	27.35	4.11	31.47	165	254	A	V



802.11g CH 11 2462MHz	*	2462	106.9	-	-	96.97	27.29	4.08	31.47	303	44	P	H
	*	2462	96.45	-	-	86.52	27.29	4.08	31.47	303	44	A	H
		2484.72	58.15	-15.85	74	48.13	27.35	4.11	31.47	303	44	P	H
		2483.56	46.89	-7.11	54	36.87	27.35	4.11	31.47	303	44	A	H
	*	2462	108.43	-	-	98.5	27.29	4.08	31.47	176	260	P	V
	*	2462	98.36	-	-	88.43	27.29	4.08	31.47	176	260	A	V
		2483.72	59.74	-14.26	74	49.72	27.35	4.11	31.47	176	260	P	V
		2483.64	48.21	-5.79	54	38.19	27.35	4.11	31.47	176	260	A	V
Remark	1. No other spurious found. 2. All results are PASS against Peak and Average limit line.												



WIFI Ant. 2	Note	Frequency (MHz)	Level (dBμV/m)	Over Limit (dB)	Limit Line (dBμV/m)	Read Level (dBμV)	Antenna Factor (dB/m)	Cable Loss (dB)	Preamp Factor (dB)	Ant Pos (cm)	Table Pos (deg)	Peak Avg. (P/A)	Pol. (H/V)
802.11g CH 12 2467MHz	*	2467	106.8	-	-	96.85	27.3	4.09	31.47	304	43	P	H
	*	2467	96.68	-	-	86.73	27.3	4.09	31.47	304	43	A	H
		2483.6	60.41	-13.59	74	50.39	27.35	4.11	31.47	304	43	P	H
		2483.8	48.56	-5.44	54	38.54	27.35	4.11	31.47	304	43	A	H
	*	2467	109.08	-	-	99.13	27.3	4.09	31.47	207	249	P	V
	*	2467	98.68	-	-	88.73	27.3	4.09	31.47	207	249	A	V
		2485.44	60.63	-13.37	74	50.6	27.36	4.11	31.47	207	249	P	V
		2483.68	48.72	-5.28	54	38.7	27.35	4.11	31.47	207	249	A	V
802.11g CH 13 2472MHz	*	2472	107.07	-	-	97.1	27.32	4.09	31.47	302	44	P	H
	*	2472	97.12	-	-	87.15	27.32	4.09	31.47	302	44	A	H
		2484.04	60.99	-13.01	74	50.97	27.35	4.11	31.47	302	44	P	H
		2483.56	49.34	-4.66	54	39.32	27.35	4.11	31.47	302	44	A	H
	*	2472	108.82	-	-	98.85	27.32	4.09	31.47	207	248	P	V
	*	2472	98.89	-	-	88.92	27.32	4.09	31.47	207	248	A	V
		2483.68	60.22	-13.78	74	50.2	27.35	4.11	31.47	207	248	P	V
		2483.52	49.37	-4.63	54	39.35	27.35	4.11	31.47	207	248	A	V
Remark	1. No other spurious found. 2. All results are PASS against Peak and Average limit line.												



2.4GHz 2400~2483.5MHz

WIFI 802.11g (Harmonic @ 3m)

WIFI Ant. 2	Note	Frequency (MHz)	Level (dBμV/m)	Over Limit (dB)	Limit Line (dBμV/m)	Read Level (dBμV)	Antenna Factor (dB/m)	Cable Loss (dB)	Preamp Factor (dB)	Ant Pos (cm)	Table Pos (deg)	Peak Avg. (P/A)	Pol. (H/V)
802.11g CH 01 2412MHz		2492	57.89	-16.11	74	47.83	27.38	4.11	31.46	102	177	P	H
		2492	44.26	-9.74	54	34.2	27.38	4.11	31.46	102	177	A	H
		4824	40.36	-33.64	74	59.79	32.18	6.17	58.31	100	0	P	H
		2492	58.69	-15.31	74	48.63	27.38	4.11	31.46	178	243	P	V
		2492	44.82	-9.18	54	34.76	27.38	4.11	31.46	178	243	A	V
		4824	39.2	-34.8	74	58.63	32.18	6.17	58.31	100	0	P	V
802.11g CH 06 2437MHz		4874	39.97	-34.03	74	59.21	32.27	6.21	58.24	100	0	P	H
		7311	46.87	-27.13	74	60.92	36.97	7.72	59.09	100	0	P	H
		4874	40.3	-33.7	74	59.54	32.27	6.21	58.24	100	0	P	V
		7311	57.95	-16.05	74	72	36.97	7.72	59.09	229	252	P	V
		7311	41.17	-12.83	54	55.22	36.97	7.72	59.09	229	252	A	V
802.11g CH 11 2462MHz		2382	56.76	-17.24	74	47.14	27.05	4.03	31.49	303	44	P	H
		2382	43.35	-10.65	54	33.73	27.05	4.03	31.49	303	44	A	H
		4924	40.01	-33.99	74	59.1	32.36	6.23	58.18	100	0	P	H
		7386	46.01	-27.99	74	59.96	37.18	7.72	59.14	100	0	P	H
		2300	55.27	-18.73	74	46.02	26.8	3.95	31.52	181	256	P	V
		2300	42.24	-11.76	54	32.99	26.8	3.95	31.52	181	256	A	V
		2382	58.29	-15.71	74	48.67	27.05	4.03	31.49	176	260	P	V
		2382	44.41	-9.59	54	34.79	27.05	4.03	31.49	176	260	A	V
		4924	40.03	-33.97	74	59.12	32.36	6.23	58.18	100	0	P	V
		7386	57.67	-16.33	74	71.62	37.18	7.72	59.14	227	269	P	V
	7386	40.76	-13.24	54	54.71	37.18	7.72	59.14	227	269	A	V	

Remark

- No other spurious found.
- All results are PASS against Peak and Average limit line.



WIFI Ant. 2	Note	Frequency (MHz)	Level (dBμV/m)	Over Limit (dB)	Limit Line (dBμV/m)	Read Level (dBμV)	Antenna Factor (dB/m)	Cable Loss (dB)	Preamp Factor (dB)	Ant Pos (cm)	Table Pos (deg)	Peak Avg. (P/A)	Pol. (H/V)
802.11g CH 12 2467MHz		2310	55.1	-18.9	74	45.79	26.83	3.97	31.52	298	51	P	H
		2310	41.98	-12.02	54	32.67	26.83	3.97	31.52	298	51	A	H
		2388	57.48	-16.52	74	47.85	27.06	4.03	31.49	304	43	P	H
		2388	43.9	-10.1	54	34.27	27.06	4.03	31.49	304	43	A	H
		4934	39.61	-34.39	74	58.67	32.38	6.24	58.18	100	0	P	H
		7401	46.68	-27.32	74	60.61	37.22	7.72	59.15	100	0	P	H
		2310	57.23	-16.77	74	47.92	26.83	3.97	31.52	210	236	P	V
		2310	44.72	-9.28	54	35.41	26.83	3.97	31.52	210	236	A	V
		2387	58.22	-15.78	74	48.59	27.06	4.03	31.49	207	249	P	V
		2387	45.1	-8.9	54	35.47	27.06	4.03	31.49	207	249	A	V
		4934	39.74	-34.26	74	58.8	32.38	6.24	58.18	100	0	P	V
		7401	58.11	-15.89	74	72.04	37.22	7.72	59.15	225	257	P	V
		7401	40.95	-13.05	54	54.88	37.22	7.72	59.15	225	257	A	V
	802.11g CH 13 2472MHz		2312	55.35	-18.65	74	46.03	26.84	3.97	31.52	302	44	P
		2312	41.7	-12.3	54	32.38	26.84	3.97	31.52	302	44	A	H
		2390	57.19	-16.81	74	47.55	27.07	4.03	31.49	300	38	P	H
		2390	45.11	-8.89	54	35.47	27.07	4.03	31.49	300	38	A	H
		4944	36.02	-37.98	74	55.05	32.4	6.24	58.16	100	0	P	H
		7416	43.96	-30.04	74	57.82	37.26	7.74	59.15	100	0	P	H
		2312	56.39	-17.61	74	47.07	26.84	3.97	31.52	207	248	P	V
		2312	42.98	-11.02	54	33.66	26.84	3.97	31.52	207	248	A	V
		2390	58.87	-15.13	74	49.23	27.07	4.03	31.49	211	253	P	V
		2390	46.92	-7.08	54	37.28	27.07	4.03	31.49	211	253	A	V
		4944	37	-37	74	56.03	32.4	6.24	58.16	100	0	P	V
		7416	56.72	-17.28	74	70.58	37.26	7.74	59.15	224	238	P	V
	7416	39.71	-14.29	54	53.57	37.26	7.74	59.15	224	238	A	V	
Remark	1. No other spurious found. 2. All results are PASS against Peak and Average limit line.												



2.4GHz 2400~2483.5MHz

WIFI 802.11n HT20 (Band Edge @ 3m)

WIFI Ant. 2	Note	Frequency (MHz)	Level (dBμV/m)	Over Limit (dB)	Limit Line (dBμV/m)	Read Level (dBμV)	Antenna Factor (dB/m)	Cable Loss (dB)	Preamp Factor (dB)	Ant Pos (cm)	Table Pos (deg)	Peak Avg. (P/A)	Pol. (H/V)
802.11n HT20 CH 01 2412MHz		2389.485	60.52	-13.48	74	50.88	27.07	4.03	31.49	100	177	P	H
		2390	47.89	-6.11	54	38.25	27.07	4.03	31.49	100	177	A	H
	*	2412	107.93	-	-	98.2	27.14	4.05	31.49	100	177	P	H
	*	2412	97.92	-	-	88.19	27.14	4.05	31.49	100	177	A	H
		2385.81	58.5	-15.5	74	48.87	27.06	4.03	31.49	290	268	P	V
		2389.59	47.69	-6.31	54	38.05	27.07	4.03	31.49	290	268	A	V
	*	2412	107.84	-	-	98.11	27.14	4.05	31.49	290	268	P	V
	*	2412	98.15	-	-	88.42	27.14	4.05	31.49	290	268	A	V
802.11n HT20 CH 06 2437MHz		2385.18	56.59	-17.41	74	46.96	27.06	4.03	31.49	108	176	P	H
		2388.26	45.28	-8.72	54	35.65	27.06	4.03	31.49	108	176	A	H
	*	2437	108.08	-	-	98.25	27.21	4.07	31.48	108	176	P	H
	*	2437	97.3	-	-	87.47	27.21	4.07	31.48	108	176	A	H
		2485.86	55.76	-18.24	74	45.73	27.36	4.11	31.47	108	176	P	H
		2487.12	45.02	-8.98	54	34.99	27.36	4.11	31.47	108	176	A	H
		2364.32	56.61	-17.39	74	47.07	26.99	4.01	31.49	100	301	P	V
		2388.4	44.69	-9.31	54	35.05	27.07	4.03	31.49	100	301	A	V
	*	2437	108.86	-	-	99.03	27.21	4.07	31.48	100	301	P	V
	*	2437	98.72	-	-	88.89	27.21	4.07	31.48	100	301	A	V
		2484.04	58.53	-15.47	74	48.51	27.35	4.11	31.47	100	301	P	V
	2483.69	45.88	-8.12	54	35.86	27.35	4.11	31.47	100	301	A	V	



802.11n HT20 CH 11 2462MHz	*	2462	105.05	-	-	95.12	27.29	4.08	31.47	106	12	P	H
	*	2462	94.7	-	-	84.77	27.29	4.08	31.47	106	12	A	H
		2485.48	57.14	-16.86	74	47.11	27.36	4.11	31.47	106	12	P	H
		2483.76	44.77	-9.23	54	34.75	27.35	4.11	31.47	106	12	A	H
	*	2462	109.63	-	-	99.7	27.29	4.08	31.47	100	344	P	V
	*	2462	99.12	-	-	89.19	27.29	4.08	31.47	100	344	A	V
		2485.52	59.59	-14.41	74	49.56	27.36	4.11	31.47	100	344	P	V
		2483.76	48.34	-5.66	54	38.32	27.35	4.11	31.47	100	344	A	V
Remark	1. No other spurious found. 2. All results are PASS against Peak and Average limit line.												



WIFI Ant. 2	Note	Frequency (MHz)	Level (dBμV/m)	Over Limit (dB)	Limit Line (dBμV/m)	Read Level (dBμV)	Antenna Factor (dB/m)	Cable Loss (dB)	Preamp Factor (dB)	Ant Pos (cm)	Table Pos (deg)	Peak Avg. (P/A)	Pol. (H/V)
802.11n HT20 CH 12 2467MHz	*	2467	105.61	-	-	95.66	27.3	4.09	31.47	107	13	P	H
	*	2467	94.84	-	-	84.89	27.3	4.09	31.47	107	13	A	H
		2487.12	58.61	-15.39	74	48.58	27.36	4.11	31.47	107	13	P	H
		2483.92	45.88	-8.12	54	35.86	27.35	4.11	31.47	107	13	A	H
	*	2467	109.49	-	-	99.54	27.3	4.09	31.47	100	344	P	V
	*	2467	98.94	-	-	88.99	27.3	4.09	31.47	100	344	A	V
		2486.32	61.52	-12.48	74	51.49	27.36	4.11	31.47	100	344	P	V
	2483.56	49.18	-4.82	54	39.16	27.35	4.11	31.47	100	344	A	V	
802.11n HT20 CH 13 2472MHz	*	2472	106.92	-	-	96.95	27.32	4.09	31.47	305	24	P	H
	*	2472	96.2	-	-	86.23	27.32	4.09	31.47	305	24	A	H
		2483.6	62.83	-11.17	74	52.81	27.35	4.11	31.47	305	24	P	H
		2483.52	48.87	-5.13	54	38.85	27.35	4.11	31.47	305	24	A	H
	*	2472	110.11	-	-	100.14	27.32	4.09	31.47	265	281	P	V
	*	2472	99.79	-	-	89.82	27.32	4.09	31.47	265	281	A	V
		2487.76	63.22	-10.78	74	53.19	27.36	4.11	31.47	265	281	P	V
	2483.56	50.34	-3.66	54	40.32	27.35	4.11	31.47	265	281	A	V	
Remark	1. No other spurious found. 2. All results are PASS against Peak and Average limit line.												



2.4GHz 2400~2483.5MHz

WIFI 802.11n HT20 (Harmonic @ 3m)

WIFI Ant. 2	Note	Frequency (MHz)	Level (dBμV/m)	Over Limit (dB)	Limit Line (dBμV/m)	Read Level (dBμV)	Antenna Factor (dB/m)	Cable Loss (dB)	Preamp Factor (dB)	Ant Pos (cm)	Table Pos (deg)	Peak Avg. (P/A)	Pol. (H/V)
802.11n HT20 CH 01 2412MHz		2492	57.72	-16.28	74	47.66	27.38	4.11	31.46	100	177	P	H
		2492	44.26	-9.74	54	34.2	27.38	4.11	31.46	100	177	A	H
		4824	34.12	-39.88	74	53.55	32.18	6.17	58.31	100	0	P	H
		2492	58.18	-15.82	74	48.12	27.38	4.11	31.46	290	268	P	V
		2492	44.36	-9.64	54	34.3	27.38	4.11	31.46	290	268	A	V
		4824	34.64	-39.36	74	54.07	32.18	6.17	58.31	100	0	P	V
802.11n HT20 CH 06 2437MHz		4874	34.46	-39.54	74	53.7	32.27	6.21	58.24	100	0	P	H
		7311	43.55	-30.45	74	57.6	36.97	7.72	59.09	100	0	P	H
		4874	34.34	-39.66	74	53.58	32.27	6.21	58.24	100	0	P	V
		7311	49.11	-24.89	74	63.16	36.97	7.72	59.09	100	0	P	V
802.11n HT20 CH 11 2462MHz		2300	53.94	-20.06	74	44.69	26.8	3.95	31.52	106	12	P	H
		2300	41.85	-12.15	54	32.6	26.8	3.95	31.52	106	12	A	H
		2382	54.81	-19.19	74	45.19	27.05	4.03	31.49	145	12	P	H
		2382	42.96	-11.04	54	33.34	27.05	4.03	31.49	145	12	A	H
		4924	35.49	-38.51	74	54.58	32.36	6.23	58.18	100	0	P	H
		7386	44.1	-29.9	74	58.05	37.18	7.72	59.14	100	0	P	H
		2300	54.5	-19.5	74	45.25	26.8	3.95	31.52	102	321	P	V
		2300	43.54	-10.46	54	34.29	26.8	3.95	31.52	102	321	A	V
		2374	56.09	-17.91	74	46.52	27.02	4.01	31.49	100	344	P	V
		2374	44.61	-9.39	54	35.04	27.02	4.01	31.49	100	344	A	V
	4924	35	-39	74	54.09	32.36	6.23	58.18	100	0	P	V	
	7386	48.57	-25.43	74	62.52	37.18	7.72	59.14	100	0	P	V	
Remark	1. No other spurious found. 2. All results are PASS against Peak and Average limit line.												



WIFI Ant. 2	Note	Frequency (MHz)	Level (dBμV/m)	Over Limit (dB)	Limit Line (dBμV/m)	Read Level (dBμV)	Antenna Factor (dB/m)	Cable Loss (dB)	Preamp Factor (dB)	Ant Pos (cm)	Table Pos (deg)	Peak Avg. (P/A)	Pol. (H/V)
802.11n HT20 CH 12 2467MHz		2310	55.33	-18.67	74	46.02	26.83	3.97	31.52	100	21	P	H
		2310	44.28	-9.72	54	34.97	26.83	3.97	31.52	100	21	A	H
		2388	56.81	-17.19	74	47.18	27.06	4.03	31.49	107	13	P	H
		2388	45.32	-8.68	54	35.69	27.06	4.03	31.49	107	13	A	H
		4934	34.32	-39.68	74	53.38	32.38	6.24	58.18	100	0	P	H
		7401	43.7	-30.3	74	57.63	37.22	7.72	59.15	100	0	P	H
		2310	54.02	-19.98	74	44.71	26.83	3.97	31.52	102	335	P	V
		2310	42.11	-11.89	54	32.8	26.83	3.97	31.52	102	335	A	V
		2390	56.08	-17.92	74	46.44	27.07	4.03	31.49	100	344	P	V
		2390	44.29	-9.71	54	34.65	27.07	4.03	31.49	100	344	A	V
		4934	34.9	-39.1	74	53.96	32.38	6.24	58.18	100	0	P	V
	7401	48.62	-25.38	74	62.55	37.22	7.72	59.15	100	0	P	V	
802.11n HT20 CH 13 2472MHz		2320	53.44	-20.56	74	44.09	26.86	3.97	31.51	102	25	P	H
		2320	41.59	-12.41	54	32.24	26.86	3.97	31.51	102	25	A	H
		2390	54.1	-19.9	74	44.46	27.07	4.03	31.49	100	16	P	H
		2390	42.47	-11.53	54	32.83	27.07	4.03	31.49	100	16	A	H
		4944	33.69	-40.31	74	52.72	32.4	6.24	58.16	100	0	P	H
		7416	42.3	-31.7	74	56.16	37.26	7.74	59.15	100	0	P	H
		2314	54.21	-19.79	74	44.88	26.84	3.97	31.51	100	329	P	V
		2314	42.75	-11.25	54	33.42	26.84	3.97	31.51	100	329	A	V
		2388	54.94	-19.06	74	45.31	27.06	4.03	31.49	100	344	P	V
		2388	43.9	-10.1	54	34.27	27.06	4.03	31.49	100	344	A	V
		4944	34.4	-39.6	74	53.43	32.4	6.24	58.16	100	0	P	V
	7416	47.87	-26.13	74	61.73	37.26	7.74	59.15	100	0	P	V	
Remark	1. No other spurious found. 2. All results are PASS against Peak and Average limit line.												



Emission below 1GHz

2.4GHz WIFI 802.11b (LF)

WIFI	Note	Frequency	Level	Over	Limit	Read	Antenna	Cable	Preamp	Ant	Table	Peak	Pol.	
Ant.		(MHz)	(dBμV/m)	(dB)	(dBμV/m)	(dBμV)	(dB/m)	(dB)	(dB)	(cm)	(deg)	(P/A)	(H/V)	
2.4GHz 802.11b LF		159.33	31.13	-12.37	43.5	45.64	16.74	1.02	32.43	-	-	P	H	
		184.17	34.26	-9.24	43.5	50.35	15.01	1.14	32.4	-	-	P	H	
		223.32	34.87	-11.13	46	50.28	15.61	1.23	32.39	-	-	P	H	
		622	34.09	-11.91	46	38.09	26.36	2	32.46	-	-	P	H	
		729.1	36.57	-9.43	46	39.03	27.65	2.18	32.39	-	-	P	H	
		745.2	40.12	-5.88	46	42	28.15	2.21	32.34	100	0	P	H	
														H
														H
														H
														H
														H
			39.72	31.98	-8.02	40	44.31	19.57	0.6	32.49	100	0	P	V
			75.63	31.97	-8.03	40	50.88	12.76	0.76	32.48	-	-	P	V
			209.28	33.45	-10.05	43.5	49.3	15.21	1.19	32.39	-	-	P	V
			619.9	32.87	-13.13	46	36.9	26.33	2	32.46	-	-	P	V
			729.1	34.41	-11.59	46	36.87	27.65	2.18	32.39	-	-	P	V
		897.8	37.23	-8.77	46	37.07	29.24	2.42	31.67	-	-	P	V	

Remark	1. No other spurious found.
	2. All results are PASS against limit line.



2.4GHz 2400~2483.5MHz

WIFI 802.11g (Band Edge @ 3m)

WIFI	Note	Frequency	Level	Over	Limit	Read	Antenna	Cable	Preamp	Ant	Table	Peak	Pol.
Ant.				Limit	Line	Level	Factor	Loss	Factor	Pos	Pos	Avg.	
1+2		(MHz)	(dBμV/m)	(dB)	(dBμV/m)	(dBμV)	(dB/m)	(dB)	(dB)	(cm)	(deg)	(P/A)	(H/V)
802.11g CH 01 2412MHz		2389.695	60.69	-13.31	74	51.05	27.07	4.03	31.49	168	352	P	H
		2389.905	49.84	-4.16	54	40.2	27.07	4.03	31.49	168	352	A	H
	*	2412	109.54	-	-	99.81	27.14	4.05	31.49	168	352	P	H
	*	2412	99.85	-	-	90.12	27.14	4.05	31.49	168	352	A	H
		2388.645	61.52	-12.48	74	51.88	27.07	4.03	31.49	100	218	P	V
		2389.905	47.33	-6.67	54	37.69	27.07	4.03	31.49	100	218	A	V
	*	2412	109.83	-	-	100.1	27.14	4.05	31.49	100	218	P	V
	*	2412	100.44	-	-	90.71	27.14	4.05	31.49	100	218	A	V
802.11g CH 06 2437MHz		2388.26	57.07	-16.93	74	47.44	27.06	4.03	31.49	115	351	P	H
		2389.38	46.28	-7.72	54	36.64	27.07	4.03	31.49	115	351	A	H
	*	2437	113	-	-	103.17	27.21	4.07	31.48	115	351	P	H
	*	2437	102.87	-	-	93.04	27.21	4.07	31.48	115	351	A	H
		2484.95	56.64	-17.36	74	46.62	27.35	4.11	31.47	115	351	P	H
		2484.39	46.3	-7.7	54	36.28	27.35	4.11	31.47	115	351	A	H
		2388.12	55.58	-18.42	74	45.95	27.06	4.03	31.49	121	215	P	V
		2387.98	45.51	-8.49	54	35.88	27.06	4.03	31.49	121	215	A	V
	*	2437	113.39	-	-	103.56	27.21	4.07	31.48	121	215	P	V
	*	2437	103.96	-	-	94.13	27.21	4.07	31.48	121	215	A	V
		2488.87	57.93	-16.07	74	47.89	27.37	4.11	31.47	121	215	P	V
		2484.95	46.92	-7.08	54	36.9	27.35	4.11	31.47	121	215	A	V



802.11g CH 11 2462MHz	*	2462	111.56	-	-	101.63	27.29	4.08	31.47	165	354	P	H
	*	2462	101.45	-	-	91.52	27.29	4.08	31.47	165	354	A	H
		2485	62.58	-11.42	74	52.56	27.35	4.11	31.47	165	354	P	H
		2483.8	48.68	-5.32	54	38.66	27.35	4.11	31.47	165	354	A	H
	*	2462	112.69	-	-	102.76	27.29	4.08	31.47	100	214	P	V
	*	2462	102.29	-	-	92.36	27.29	4.08	31.47	100	214	A	V
		2483.52	62.94	-11.06	74	52.92	27.35	4.11	31.47	100	214	P	V
		2483.52	49.56	-4.44	54	39.54	27.35	4.11	31.47	100	214	A	V
Remark	1. No other spurious found. 2. All results are PASS against Peak and Average limit line.												



WIFI Ant. 1+2	Note	Frequency (MHz)	Level (dBμV/m)	Over Limit (dB)	Limit Line (dBμV/m)	Read Level (dBμV)	Antenna Factor (dB/m)	Cable Loss (dB)	Preamp Factor (dB)	Ant Pos (cm)	Table Pos (deg)	Peak Avg. (P/A)	Pol. (H/V)
802.11g CH 12 2467MHz	*	2467	108.41	-	-	98.46	27.3	4.09	31.47	166	356	P	H
	*	2467	99.1	-	-	89.15	27.3	4.09	31.47	166	356	A	H
		2485.68	59.84	-14.16	74	49.81	27.36	4.11	31.47	166	356	P	H
		2484.88	47.49	-6.51	54	37.47	27.35	4.11	31.47	166	356	A	H
	*	2467	108.87	-	-	98.92	27.3	4.09	31.47	100	215	P	V
	*	2467	99.97	-	-	90.02	27.3	4.09	31.47	100	215	A	V
		2483.64	61.89	-12.11	74	51.87	27.35	4.11	31.47	100	215	P	V
		2483.56	50.06	-3.94	54	40.04	27.35	4.11	31.47	100	215	A	V
802.11g CH 13 2472MHz	*	2472	105.61	-	-	95.64	27.32	4.09	31.47	164	354	P	H
	*	2472	96.95	-	-	86.98	27.32	4.09	31.47	164	354	A	H
		2483.64	58.21	-15.79	74	48.19	27.35	4.11	31.47	164	354	P	H
		2483.56	45.81	-8.19	54	35.79	27.35	4.11	31.47	164	354	A	H
	*	2472	106.67	-	-	96.7	27.32	4.09	31.47	100	217	P	V
	*	2472	97.47	-	-	87.5	27.32	4.09	31.47	100	217	A	V
		2483.52	61.32	-12.68	74	51.3	27.35	4.11	31.47	100	217	P	V
		2483.72	50.2	-3.8	54	40.18	27.35	4.11	31.47	100	217	A	V
Remark	1. No other spurious found. 2. All results are PASS against Peak and Average limit line.												



2.4GHz 2400~2483.5MHz

WIFI 802.11g (Harmonic @ 3m)

WIFI Ant. 1+2	Note	Frequency (MHz)	Level (dBμV/m)	Over Limit (dB)	Limit Line (dBμV/m)	Read Level (dBμV)	Antenna Factor (dB/m)	Cable Loss (dB)	Preamp Factor (dB)	Ant Pos (cm)	Table Pos (deg)	Peak Avg. (P/A)	Pol. (H/V)
802.11g CH 01 2412MHz		4824	40.4	-33.6	74	59.83	32.18	6.17	58.31	100	0	P	H
		4824	40.36	-33.64	74	59.79	32.18	6.17	58.31	100	0	P	V
802.11g CH 06 2437MHz		2280	55	-19	74	45.82	26.74	3.94	31.52	115	351	P	H
		2280	42.14	-11.86	54	32.96	26.74	3.94	31.52	115	351	A	H
		4874	41.29	-32.71	74	60.53	32.27	6.21	58.24	100	0	P	H
		7311	56.29	-17.71	74	70.34	36.97	7.72	59.09	245	359	P	H
		7311	42.37	-11.63	54	56.42	36.97	7.72	59.09	245	359	A	H
		4874	42	-32	74	61.24	32.27	6.21	58.24	100	0	P	V
		7311	61.43	-12.57	74	75.48	36.97	7.72	59.09	224	258	P	V
		7311	45.93	-8.07	54	59.98	36.97	7.72	59.09	224	258	A	V
802.11g CH 11 2462MHz		2300	55.55	-18.45	74	46.3	26.8	3.95	31.52	160	339	P	H
		2300	43.78	-10.22	54	34.53	26.8	3.95	31.52	160	339	A	H
		2380	57.39	-16.61	74	47.78	27.04	4.03	31.49	165	354	P	H
		2380	44.89	-9.11	54	35.28	27.04	4.03	31.49	165	354	A	H
		4924	40.52	-33.48	74	59.61	32.36	6.23	58.18	100	0	P	H
		7386	49.73	-24.27	74	63.68	37.18	7.72	59.14	100	0	P	H
		4924	41.1	-32.9	74	60.19	32.36	6.23	58.18	100	0	P	V
		7386	58.64	-15.36	74	72.59	37.18	7.72	59.14	234	256	P	V
		7386	42.34	-11.66	54	56.29	37.18	7.72	59.14	234	256	A	V
Remark	1. No other spurious found. 2. All results are PASS against Peak and Average limit line.												



WiFi Ant. 1+2	Note	Frequency (MHz)	Level (dBμV/m)	Over Limit (dB)	Limit Line (dBμV/m)	Read Level (dBμV)	Antenna Factor (dB/m)	Cable Loss (dB)	Preamp Factor (dB)	Ant Pos (cm)	Table Pos (deg)	Peak Avg. (P/A)	Pol. (H/V)
802.11g CH 12 2467MHz		2312	54.14	-19.86	74	44.82	26.84	3.97	31.52	160	349	P	H
		2312	41.96	-12.04	54	32.64	26.84	3.97	31.52	160	349	A	H
		2386	56.42	-17.58	74	46.79	27.06	4.03	31.49	166	356	P	H
		2386	44.58	-9.42	54	34.95	27.06	4.03	31.49	166	356	A	H
		4934	39.93	-34.07	74	58.99	32.38	6.24	58.18	100	0	P	H
		7401	46.8	-27.2	74	60.73	37.22	7.72	59.15	100	0	P	H
		4934	40.6	-33.4	74	59.66	32.38	6.24	58.18	100	0	P	V
		7401	54.68	-19.32	74	68.61	37.22	7.72	59.15	234	257	P	V
		7401	38.61	-15.39	54	52.54	37.22	7.72	59.15	234	257	A	V
802.11g CH 13 2472MHz		2318	54.57	-19.43	74	45.23	26.85	3.97	31.51	158	357	P	H
		2318	43.01	-10.99	54	33.67	26.85	3.97	31.51	158	357	A	H
		2390	56	-18	74	46.36	27.07	4.03	31.49	164	354	P	H
		2390	43.75	-10.25	54	34.11	27.07	4.03	31.49	164	354	A	H
		4944	39.96	-34.04	74	58.99	32.4	6.24	58.16	100	0	P	H
		7416	44.23	-29.77	74	58.09	37.26	7.74	59.15	100	0	P	H
		4944	41.28	-32.72	74	60.31	32.4	6.24	58.16	100	0	P	V
			7416	46.35	-27.65	74	60.21	37.26	7.74	59.15	100	0	P
Remark	<ol style="list-style-type: none"> No other spurious found. All results are PASS against Peak and Average limit line. 												



2.4GHz 2400~2483.5MHz

WIFI 802.11n HT20 (Band Edge @ 3m)

WIFI Ant. 1+2	Note	Frequency (MHz)	Level (dBμV/m)	Over Limit (dB)	Limit Line (dBμV/m)	Read Level (dBμV)	Antenna Factor (dB/m)	Cable Loss (dB)	Preamp Factor (dB)	Ant Pos (cm)	Table Pos (deg)	Peak Avg. (P/A)	Pol. (H/V)
802.11n HT20 CH 01 2412MHz		2388.75	61.79	-12.21	74	52.15	27.07	4.03	31.49	119	349	P	H
		2388.645	48.87	-5.13	54	39.23	27.07	4.03	31.49	119	349	A	H
	*	2412	107.39	-	-	97.66	27.14	4.05	31.49	119	349	P	H
	*	2412	97.79	-	-	88.06	27.14	4.05	31.49	119	349	A	H
		2389.485	64.53	-9.47	74	54.89	27.07	4.03	31.49	101	217	P	V
		2389.905	50.41	-3.59	54	40.77	27.07	4.03	31.49	101	217	A	V
	*	2412	108.07	-	-	98.34	27.14	4.05	31.49	101	217	P	V
	*	2412	98.42	-	-	88.69	27.14	4.05	31.49	101	217	A	V
802.11n HT20 CH 06 2437MHz		2388.26	56.91	-17.09	74	47.28	27.06	4.03	31.49	115	350	P	H
		2389.66	46.27	-7.73	54	36.63	27.07	4.03	31.49	115	350	A	H
	*	2437	111.13	-	-	101.3	27.21	4.07	31.48	115	350	P	H
	*	2437	101.75	-	-	91.92	27.21	4.07	31.48	115	350	A	H
		2489.15	56.52	-17.48	74	46.48	27.37	4.11	31.47	115	350	P	H
		2484.39	45.88	-8.12	54	35.86	27.35	4.11	31.47	115	350	A	H
		2386.3	55.88	-18.12	74	46.25	27.06	4.03	31.49	122	215	P	V
		2389.8	45.72	-8.28	54	36.08	27.07	4.03	31.49	122	215	A	V
	*	2437	112.32	-	-	102.49	27.21	4.07	31.48	122	215	P	V
	*	2437	102.78	-	-	92.95	27.21	4.07	31.48	122	215	A	V
		2483.62	58.28	-15.72	74	48.26	27.35	4.11	31.47	122	215	P	V
	2484.67	46.9	-7.1	54	36.88	27.35	4.11	31.47	122	215	A	V	



802.11n HT20 CH 11 2462MHz	*	2462	109.12	-	-	99.19	27.29	4.08	31.47	112	353	P	H
	*	2462	99.74	-	-	89.81	27.29	4.08	31.47	112	353	A	H
		2483.88	61.86	-12.14	74	51.84	27.35	4.11	31.47	112	353	P	H
		2483.6	49.22	-4.78	54	39.2	27.35	4.11	31.47	112	353	A	H
	*	2462	110.52	-	-	100.59	27.29	4.08	31.47	100	215	P	V
	*	2462	101.52	-	-	91.59	27.29	4.08	31.47	100	215	A	V
		2484	62.44	-11.56	74	52.42	27.35	4.11	31.47	100	215	P	V
		2484.48	50.25	-3.75	54	40.23	27.35	4.11	31.47	100	215	A	V
Remark	1. No other spurious found. 2. All results are PASS against Peak and Average limit line.												



WIFI Ant. 1+2	Note	Frequency (MHz)	Level (dBμV/m)	Over Limit (dB)	Limit Line (dBμV/m)	Read Level (dBμV)	Antenna Factor (dB/m)	Cable Loss (dB)	Preamp Factor (dB)	Ant Pos (cm)	Table Pos (deg)	Peak Avg. (P/A)	Pol. (H/V)
802.11n HT20 CH 12 2467MHz	*	2467	107.93	-	-	97.98	27.3	4.09	31.47	189	355	P	H
	*	2467	97.83	-	-	87.88	27.3	4.09	31.47	189	355	A	H
		2484.48	61.26	-12.74	74	51.24	27.35	4.11	31.47	189	355	P	H
		2484.16	50.01	-3.99	54	39.99	27.35	4.11	31.47	189	355	A	H
	*	2467	109.25	-	-	99.3	27.3	4.09	31.47	100	214	P	V
	*	2467	99.27	-	-	89.32	27.3	4.09	31.47	100	214	A	V
		2484.32	62.14	-11.86	74	52.12	27.35	4.11	31.47	100	214	P	V
	2484.36	50.55	-3.45	54	40.53	27.35	4.11	31.47	100	214	A	V	
802.11n HT20 CH 13 2472MHz	*	2472	105.54	-	-	95.57	27.32	4.09	31.47	188	357	P	H
	*	2472	95.85	-	-	85.88	27.32	4.09	31.47	188	357	A	H
		2484.44	58.96	-15.04	74	48.94	27.35	4.11	31.47	188	357	P	H
		2484	48.19	-5.81	54	38.17	27.35	4.11	31.47	188	357	A	H
	*	2472	106.4	-	-	96.43	27.32	4.09	31.47	100	214	P	V
	*	2472	96.97	-	-	87	27.32	4.09	31.47	100	214	A	V
		2485.08	60.91	-13.09	74	50.88	27.36	4.11	31.47	100	214	P	V
	2484.92	50.35	-3.65	54	40.33	27.35	4.11	31.47	100	214	P	V	
Remark	1. No other spurious found. 2. All results are PASS against Peak and Average limit line.												



2.4GHz 2400~2483.5MHz

WIFI 802.11n HT20 (Harmonic @ 3m)

WIFI Ant. 1+2	Note	Frequency (MHz)	Level (dBμV/m)	Over Limit (dB)	Limit Line (dBμV/m)	Read Level (dBμV)	Antenna Factor (dB/m)	Cable Loss (dB)	Preamp Factor (dB)	Ant Pos (cm)	Table Pos (deg)	Peak Avg. (P/A)	Pol. (H/V)
802.11n HT20 CH 01 2412MHz		4824	40.62	-33.38	74	60.05	32.18	6.17	58.31	100	0	P	H
		4824	40.11	-33.89	74	59.54	32.18	6.17	58.31	100	0	P	V
802.11n HT20 CH 06 2437MHz		2280	54.44	-19.56	74	45.26	26.74	3.94	31.52	115	350	P	H
		2280	42.3	-11.7	54	33.12	26.74	3.94	31.52	115	350	A	H
		4874	41.41	-32.59	74	60.65	32.27	6.21	58.24	100	0	P	H
		7311	53.96	-20.04	74	68.01	36.97	7.72	59.09	255	0	P	H
		7311	39.81	-14.19	54	53.86	36.97	7.72	59.09	255	0	A	H
		4874	43.18	-30.82	74	62.42	32.27	6.21	58.24	100	0	P	V
		7311	58.96	-15.04	74	73.01	36.97	7.72	59.09	222	249	P	V
802.11n HT20 CH 11 2462MHz		2300	55.28	-18.72	74	46.03	26.8	3.95	31.52	112	353	P	H
		2300	41.92	-12.08	54	32.67	26.8	3.95	31.52	112	353	A	H
		2380	56.5	-17.5	74	46.89	27.04	4.03	31.49	116	358	P	H
		2380	43.95	-10.05	54	34.34	27.04	4.03	31.49	116	358	A	H
		4924	39.96	-34.04	74	59.05	32.36	6.23	58.18	100	0	P	H
		7386	48.34	-25.66	74	62.29	37.18	7.72	59.14	100	0	P	H
		4924	40.86	-33.14	74	59.95	32.36	6.23	58.18	100	0	P	V
		7386	55.35	-18.65	74	69.3	37.18	7.72	59.14	100	304	P	V
Remark	1. No other spurious found.												
	2. All results are PASS against Peak and Average limit line.												



WIFI Ant. 1+2	Note	Frequency (MHz)	Level (dBμV/m)	Over Limit (dB)	Limit Line (dBμV/m)	Read Level (dBμV)	Antenna Factor (dB/m)	Cable Loss (dB)	Preamp Factor (dB)	Ant Pos (cm)	Table Pos (deg)	Peak Avg. (P/A)	Pol. (H/V)
802.11n HT20 CH 12 2467MHz		2314	54.56	-19.44	74	45.23	26.84	3.97	31.51	192	349	P	H
		2314	41.84	-12.16	54	32.51	26.84	3.97	31.51	192	349	A	H
		2386	56.38	-17.62	74	46.75	27.06	4.03	31.49	189	355	P	H
		2386	43.21	-10.79	54	33.58	27.06	4.03	31.49	189	355	A	H
		4934	40.44	-33.56	74	59.5	32.38	6.24	58.18	100	0	P	H
		7401	46.15	-27.85	74	60.08	37.22	7.72	59.15	100	0	P	H
		4934	41.38	-32.62	74	60.44	32.38	6.24	58.18	100	0	P	V
802.11n HT20 CH 13 2472MHz		2316	54.2	-19.8	74	44.86	26.85	3.97	31.51	193	352	P	H
		2316	41.07	-12.93	54	31.73	26.85	3.97	31.51	193	352	A	H
		2390	55.13	-18.87	74	45.49	27.07	4.03	31.49	188	357	P	H
		2390	42.32	-11.68	54	32.68	27.07	4.03	31.49	188	357	A	H
		4944	40.33	-33.67	74	59.36	32.4	6.24	58.16	100	0	P	H
		7416	45.61	-28.39	74	59.47	37.26	7.74	59.15	100	0	P	H
		4944	40.42	-33.58	74	59.45	32.4	6.24	58.16	100	0	P	V
	7416	46.66	-27.34	74	60.52	37.26	7.74	59.15	100	0	P	V	
Remark	1. No other spurious found. 2. All results are PASS against Peak and Average limit line.												



Emission below 1GHz

2.4GHz WIFI 802.11n HT20 (LF)

WIFI	Note	Frequency	Level	Over	Limit	Read	Antenna	Cable	Preamp	Ant	Table	Peak	Pol.
Ant.				Limit	Line	Level	Factor	Loss	Factor	Pos	Pos	Avg.	
1+2		(MHz)	(dBμV/m)	(dB)	(dBμV/m)	(dBμV)	(dB/m)	(dB)	(dB)	(cm)	(deg)	(P/A)	(H/V)
2.4GHz 802.11n HT20 LF		184.17	34.01	-9.49	43.5	50.1	15.01	1.14	32.4	100	0	P	H
		214.95	33.31	-10.19	43.5	49.11	15.26	1.19	32.39	-	-	P	H
		239.79	32.97	-13.03	46	46.58	17.34	1.28	32.38	-	-	P	H
		615	33.72	-12.28	46	37.94	26.15	2	32.46	-	-	P	H
		774.6	28.83	-17.17	46	30.38	28.35	2.24	32.25	-	-	P	H
		972	33.15	-20.85	54	30.32	31.09	2.51	31	-	-	P	H
		39.72	33.73	-6.27	40	46.06	19.57	0.6	32.49	100	0	P	V
		59.43	32.3	-7.7	40	52.14	11.93	0.68	32.49	-	-	P	V
		75.63	30.42	-9.58	40	49.33	12.76	0.76	32.48	-	-	P	V
		482	26.97	-19.03	46	33.67	23.84	1.77	32.37	-	-	P	V
		603.1	31.76	-14.24	46	36.44	25.73	1.97	32.46	-	-	P	V
	963.6	32.37	-21.63	54	29.61	31.1	2.51	31.08	-	-	P	V	
Remark	1. No other spurious found. 2. All results are PASS against limit line.												



Note symbol

*	Fundamental Frequency which can be ignored. However, the level of any unwanted emissions shall not exceed the level of the fundamental frequency.
!	Test result is over limit line.
P/A	Peak or Average
H/V	Horizontal or Vertical



A calculation example for radiated spurious emission is shown as below:

WIFI	Note	Frequency	Level	Over	Limit	Read	Antenna	Cable	Preamp	Ant	Table	Peak	Pol.
Ant.				Limit	Line	Level	Factor	Loss	Factor	Pos	Pos	Avg.	
1+2		(MHz)	(dBμV/m)	(dB)	(dBμV/m)	(dBμV)	(dB/m)	(dB)	(dB)	(cm)	(deg)	(P/A)	(H/V)
802.11b		2390	55.45	-18.55	74	54.51	32.22	4.58	35.86	103	308	P	H
CH 01													
2412MHz		2390	43.54	-10.46	54	42.6	32.22	4.58	35.86	103	308	A	H

- Level(dBμV/m) =
Antenna Factor(dB/m) + Cable Loss(dB) + Read Level(dBμV) - Preamp Factor(dB)
- Over Limit(dB) = Level(dBμV/m) – Limit Line(dBμV/m)

For Peak Limit @ 2390MHz:

- Level(dBμV/m)
= Antenna Factor(dB/m) + Cable Loss(dB) + Read Level(dBμV) - Preamp Factor(dB)
= 32.22(dB/m) + 4.58(dB) + 54.51(dBμV) – 35.86 (dB)
= 55.45 (dBμV/m)
- Over Limit(dB)
= Level(dBμV/m) – Limit Line(dBμV/m)
= 55.45(dBμV/m) – 74(dBμV/m)
= -18.55(dB)

For Average Limit @ 2390MHz:

- Level(dBμV/m)
= Antenna Factor(dB/m) + Cable Loss(dB) + Read Level(dBμV) - Preamp Factor(dB)
= 32.22(dB/m) + 4.58(dB) + 42.6(dBμV) – 35.86 (dB)
= 43.54 (dBμV/m)
- Over Limit(dB)
= Level(dBμV/m) – Limit Line(dBμV/m)
= 43.54(dBμV/m) – 54(dBμV/m)
= -10.46(dB)

Both peak and average measured complies with the limit line, so test result is “PASS”.



Appendix D. Radiated Spurious Emission Plots

Test Engineer :	Nick Yu and Peter Chiu	Temperature :	22~26°C
		Relative Humidity :	56~62%

Note symbol

-L	Low channel location
-R	High channel location