

#01_WLAN2.4GHz_802.11b 1Mbps_Right Cheek_Ch1;Ant 1

Communication System: 802.11b ; Frequency: 2412 MHz;Duty Cycle: 1:1

Medium: HSL_2450_180730 Medium parameters used: $f = 2412$ MHz; $\sigma = 1.714$ S/m; $\epsilon_r = 38.946$; $\rho = 1000$ kg/m³

Ambient Temperature : 23.1 °C ; Liquid Temperature : 22.1 °C

DASY5 Configuration

- Probe: EX3DV4 - SN3925;ConvF(7.72, 7.72, 7.72) @ 2412 MHz;Calibrated: 2018/5/31
- Sensor-Surface: 1.4mm (Mechanical Surface Detection)
- Electronics: DAE4 Sn854; Calibrated: 2018/6/14
- Phantom: SAM_Right; Type: QD000P40CD; Serial: S/N:1796
- Measurement SW: DASY52, Version 52.10 (1); SEMCAD X Version 14.6.11 (7439)

Area Scan (81x81x1): Interpolated grid: dx=1.200 mm, dy=1.200 mm

Maximum value of SAR (interpolated) = 0.193 W/kg

Zoom Scan (7x7x7)/Cube 0: Measurement grid: dx=5mm, dy=5mm, dz=5mm

Reference Value = 7.314 V/m; Power Drift = -0.15 dB

Peak SAR (extrapolated) = 0.177 W/kg

SAR(1 g) = 0.091 W/kg; SAR(10 g) = 0.044 W/kg

Maximum value of SAR (measured) = 0.145 W/kg

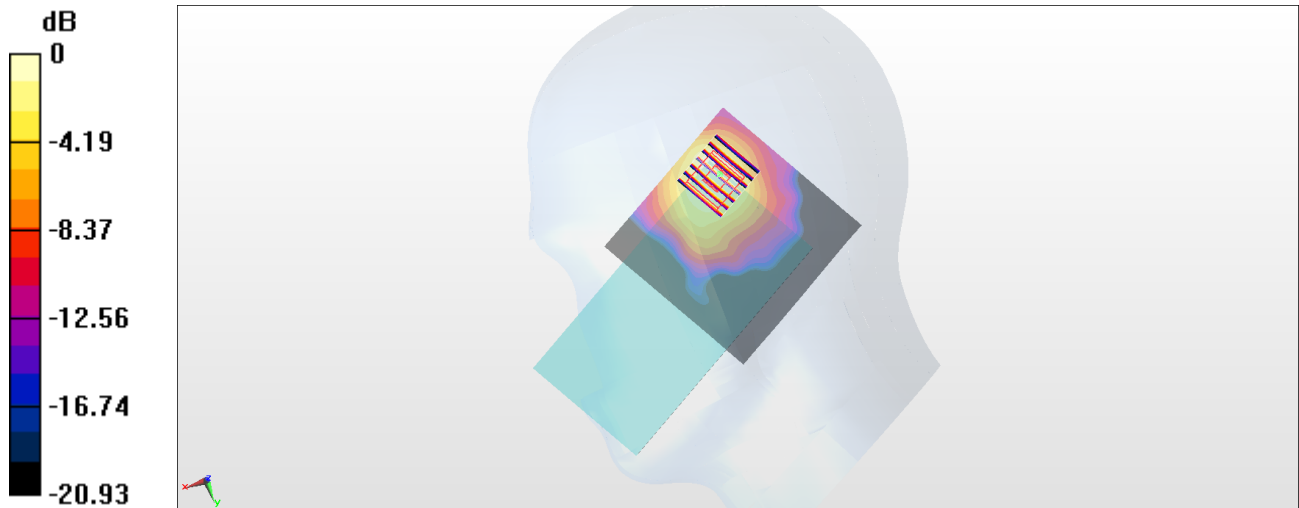

0 dB = 0.145 W/kg = -8.39 dBW/kg

#02_WLAN5GHz_802.11n-HT40 MCS0_Left Cheek_Ch62;Ant 1

Communication System: 802.11n; Frequency: 5310 MHz; Duty Cycle: 1:1.114

Medium: HSL_5G_180730 Medium parameters used: $f = 5310$ MHz; $\sigma = 4.605$ S/m; $\epsilon_r = 35.898$; $\rho = 1000$ kg/m³

Ambient Temperature : 23.1 °C ; Liquid Temperature : 22.1 °C

DASY5 Configuration

- Probe: EX3DV4 - SN3925; ConvF(5.08, 5.08, 5.08) @ 5310 MHz; Calibrated: 2018/5/31
- Sensor-Surface: 1.4mm (Mechanical Surface Detection)
- Electronics: DAE4 Sn854; Calibrated: 2018/6/14
- Phantom: SAM_Right; Type: QD000P40CD; Serial: S/N:1796
- Measurement SW: DASY52, Version 52.10 (1); SEMCAD X Version 14.6.11 (7439)

Area Scan (101x71x1): Interpolated grid: dx=1.000 mm, dy=1.000 mm

Maximum value of SAR (interpolated) = 0.149 W/kg

Zoom Scan (7x7x7)/Cube 0: Measurement grid: dx=4mm, dy=4mm, dz=1.4mm

Reference Value = 4.154 V/m; Power Drift = 0.08 dB

Peak SAR (extrapolated) = 0.211 W/kg

SAR(1 g) = 0.039 W/kg; SAR(10 g) = 0.010 W/kg

Maximum value of SAR (measured) = 0.110 W/kg

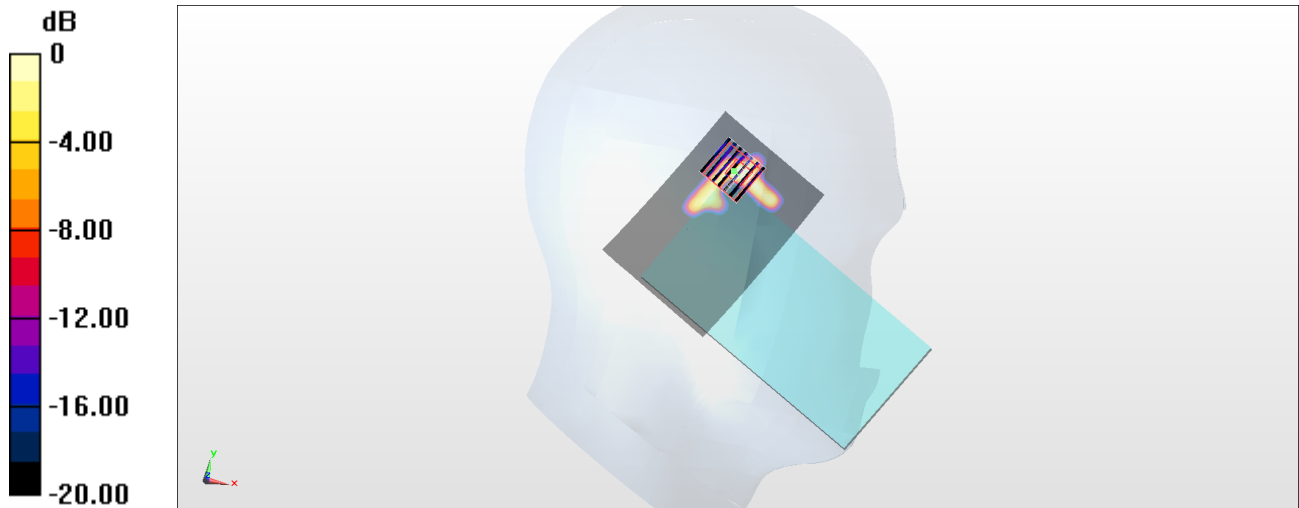

0 dB = 0.110 W/kg = -9.59 dBW/kg

#03_WLAN5GHz_802.11n-HT40 MCS0_Left Cheek_Ch110;Ant 1

Communication System: 802.11n ; Frequency: 5550 MHz;Duty Cycle: 1:1.114

Medium: HSL_5G_180730 Medium parameters used: $f = 5550$ MHz; $\sigma = 4.822$ S/m; $\epsilon_r = 35.643$; $\rho = 1000$ kg/m³

Ambient Temperature : 23.1 °C ; Liquid Temperature : 22.1 °C

DASY5 Configuration

- Probe: EX3DV4 - SN3925;ConvF(4.64, 4.64, 4.64) @ 5550 MHz;Calibrated: 2018/5/31
- Sensor-Surface: 1.4mm (Mechanical Surface Detection)
- Electronics: DAE4 Sn854; Calibrated: 2018/6/14
- Phantom: SAM_Right; Type: QD000P40CD; Serial: S/N:1796
- Measurement SW: DASY52, Version 52.10 (1); SEMCAD X Version 14.6.11 (7439)

Area Scan (101x71x1): Interpolated grid: dx=1.000 mm, dy=1.000 mm

Maximum value of SAR (interpolated) = 0.110 W/kg

Zoom Scan (7x7x7)/Cube 0: Measurement grid: dx=4mm, dy=4mm, dz=1.4mm

Reference Value = 3.673 V/m; Power Drift = 0.09 dB

Peak SAR (extrapolated) = 0.237 W/kg

SAR(1 g) = 0.034 W/kg; SAR(10 g) = 0.011 W/kg

Maximum value of SAR (measured) = 0.121 W/kg

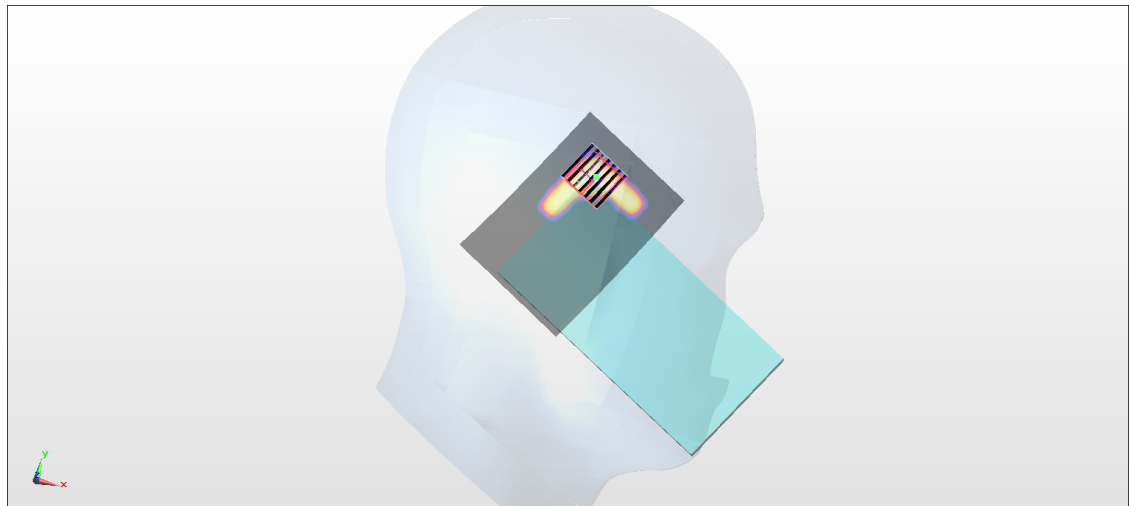
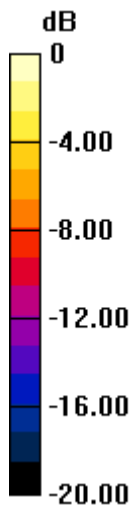

0 dB = 0.121 W/kg = -9.17 dBW/kg

#04_WLAN5GHz_802.11n-HT40 MCS0_Left Cheek_Ch151;Ant 1

Communication System: 802.11n ; Frequency: 5755 MHz;Duty Cycle: 1:1.114

Medium: HSL_5G_180730 Medium parameters used : $f = 5755$ MHz; $\sigma = 5.056$ S/m; $\epsilon_r = 35.425$; $\rho = 1000$ kg/m³

Ambient Temperature : 23.1 °C ; Liquid Temperature : 22.1 °C

DASY5 Configuration

- Probe: EX3DV4 - SN3925;ConvF(4.89, 4.89, 4.89) @ 5755 MHz;Calibrated: 2018/5/31
- Sensor-Surface: 1.4mm (Mechanical Surface Detection)
- Electronics: DAE4 Sn854; Calibrated: 2018/6/14
- Phantom: SAM_Right; Type: QD000P40CD; Serial: S/N:1796
- Measurement SW: DASY52, Version 52.10 (1); SEMCAD X Version 14.6.11 (7439)

Area Scan (101x71x1): Interpolated grid: dx=1.000 mm, dy=1.000 mm

Maximum value of SAR (interpolated) = 0.112 W/kg

Zoom Scan (7x7x7)/Cube 0: Measurement grid: dx=4mm, dy=4mm, dz=1.4mm

Reference Value = 3.399 V/m; Power Drift = -0.16 dB

Peak SAR (extrapolated) = 0.312 W/kg

SAR(1 g) = 0.040 W/kg; SAR(10 g) = 0.00997 W/kg

Maximum value of SAR (measured) = 0.126 W/kg

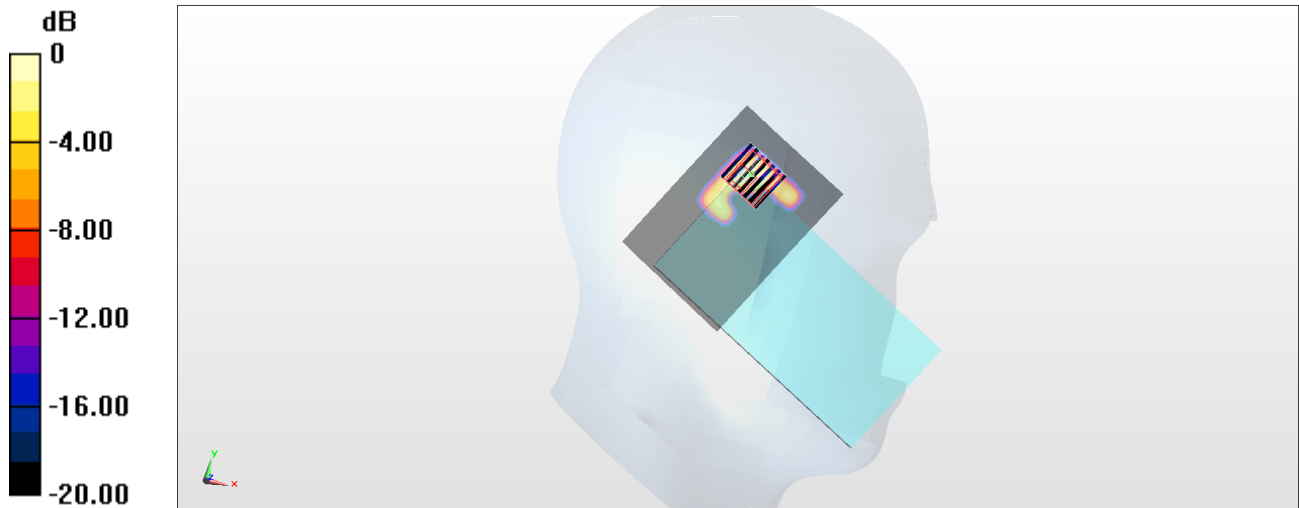

0 dB = 0.126 W/kg = -9.00 dBW/kg

#05_WLAN2.4GHz_802.11b 1Mbps_Top Side_10mm_Ch1;Ant 1

Communication System: 802.11b; Frequency: 2412 MHz; Duty Cycle: 1:1

Medium: MSL_2450_180730 Medium parameters used: $f = 2412$ MHz; $\sigma = 1.944$ S/m; $\epsilon_r = 52.077$; $\rho = 1000$ kg/m³

Ambient Temperature : 23.1 °C ; Liquid Temperature : 22.1 °C

DASY5 Configuration

- Probe: EX3DV4 - SN3925; ConvF(7.63, 7.63, 7.63) @ 2412 MHz; Calibrated: 2018/5/31
- Sensor-Surface: 1.4mm (Mechanical Surface Detection)
- Electronics: DAE4 Sn854; Calibrated: 2018/6/14
- Phantom: SAM_Right; Type: QD000P40CD; Serial: S/N:1796
- Measurement SW: DASY52, Version 52.10 (1); SEMCAD X Version 14.6.11 (7439)

Area Scan (51x71x1): Interpolated grid: dx=1.200 mm, dy=1.200 mm

Maximum value of SAR (interpolated) = 0.0277 W/kg

Zoom Scan (7x8x7)/Cube 0: Measurement grid: dx=5mm, dy=5mm, dz=5mm

Reference Value = 2.786 V/m; Power Drift = -0.13 dB

Peak SAR (extrapolated) = 0.0620 W/kg

SAR(1 g) = 0.014 W/kg; SAR(10 g) = 0.0065 W/kg

Maximum value of SAR (measured) = 0.0240 W/kg

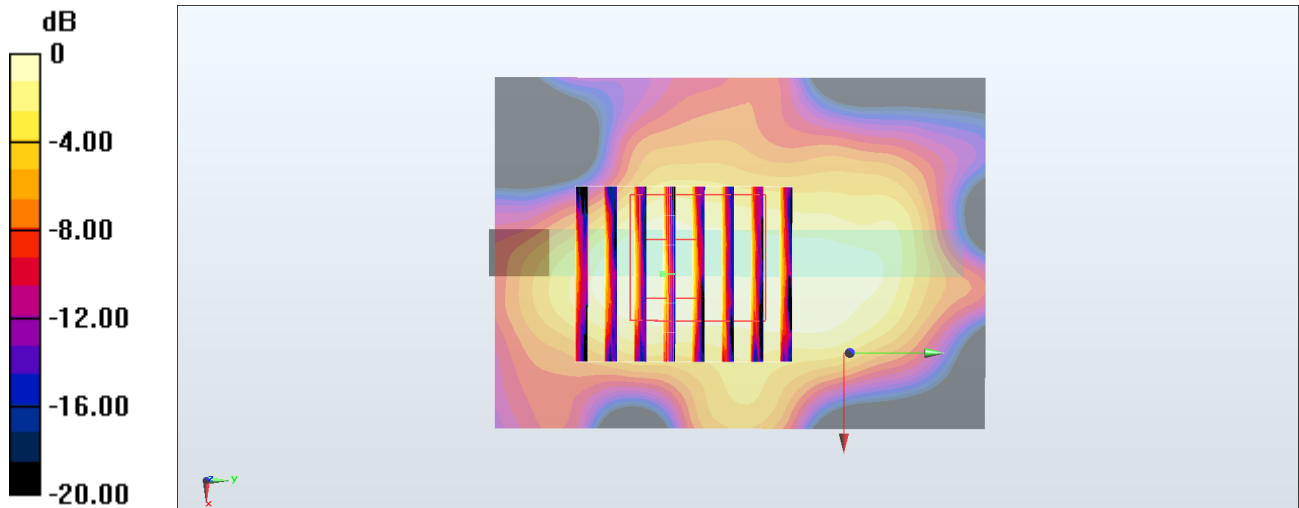

0 dB = 0.0240 W/kg = -16.20 dBW/kg

#06_WLAN2.4GHz_802.11b 1Mbps_Left Side_10mm_Ch1;Ant 1

Communication System: 802.11b; Frequency: 2412 MHz; Duty Cycle: 1:1

Medium: MSL_2450_180730 Medium parameters used: $f = 2412$ MHz; $\sigma = 1.944$ S/m; $\epsilon_r = 52.077$; $\rho = 1000$ kg/m³

Ambient Temperature : 23.1 °C ; Liquid Temperature : 22.1 °C

DASY5 Configuration

- Probe: EX3DV4 - SN3925; ConvF(7.63, 7.63, 7.63) @ 2412 MHz; Calibrated: 2018/5/31
- Sensor-Surface: 1.4mm (Mechanical Surface Detection)
- Electronics: DAE4 Sn854; Calibrated: 2018/6/14
- Phantom: SAM_Right; Type: QD000P40CD; Serial: S/N:1796
- Measurement SW: DASY52, Version 52.10 (1); SEMCAD X Version 14.6.11 (7439)

Area Scan (51x71x1): Interpolated grid: dx=1.200 mm, dy=1.200 mm

Maximum value of SAR (interpolated) = 0.0364 W/kg

Zoom Scan (7x7x7)/Cube 0: Measurement grid: dx=5mm, dy=5mm, dz=5mm

Reference Value = 1.802 V/m; Power Drift = 0.09 dB

Peak SAR (extrapolated) = 0.0200 W/kg

SAR(1 g) = 0.00648 W/kg; SAR(10 g) = 0.002 W/kg

Maximum value of SAR (measured) = 0.0127 W/kg

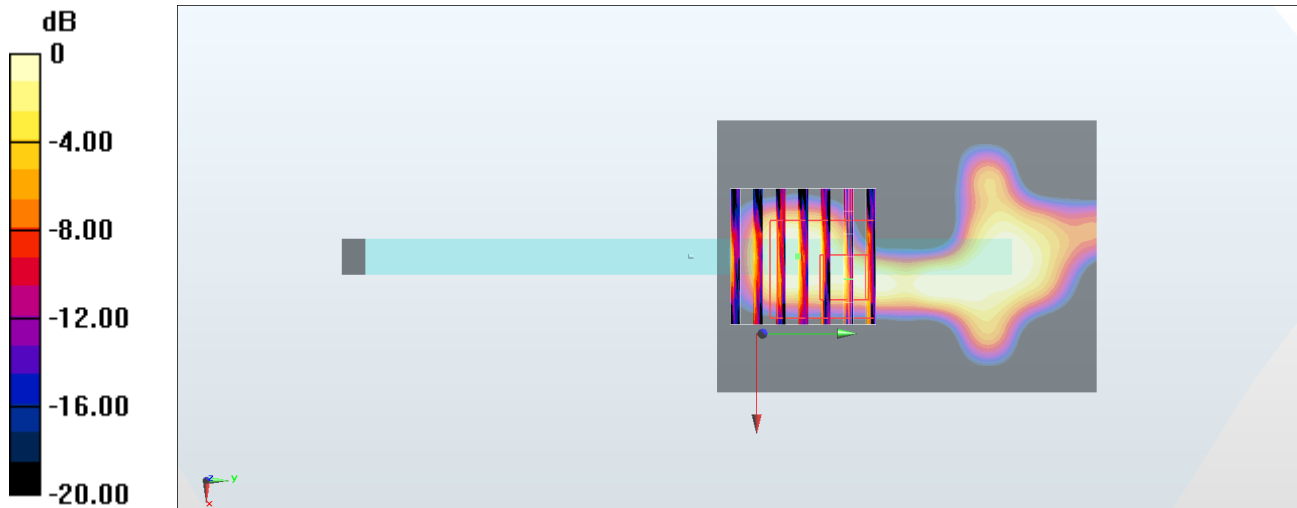

0 dB = 0.0127 W/kg = -18.96 dBW/kg

#07_WLAN5GHz_802.11n-HT40 MCS0_Back_10mm_Ch38;Ant 1

Communication System: 802.11n ; Frequency: 5190 MHz;Duty Cycle: 1:1.114

Medium: MSL_5G_180731 Medium parameters used: $f = 5190 \text{ MHz}$; $\sigma = 5.155 \text{ S/m}$; $\epsilon_r = 47.263$; $\rho = 1000 \text{ kg/m}^3$

Ambient Temperature : $23.2 \text{ }^\circ\text{C}$; Liquid Temperature : $22.2 \text{ }^\circ\text{C}$

DASY5 Configuration

- Probe: EX3DV4 - SN3925;ConvF(4.44, 4.44, 4.44) @ 5190 MHz;Calibrated: 2018/5/31
- Sensor-Surface: 1.4mm (Mechanical Surface Detection)
- Electronics: DAE4 Sn854; Calibrated: 2018/6/14
- Phantom: SAM_Right; Type: QD000P40CD; Serial: S/N:1796
- Measurement SW: DASY52, Version 52.10 (1); SEMCAD X Version 14.6.11 (7439)

Area Scan (61x71x1): Interpolated grid: $dx=1.000 \text{ mm}$, $dy=1.000 \text{ mm}$

Maximum value of SAR (interpolated) = 0.0789 W/kg

Zoom Scan (7x7x7)/Cube 0: Measurement grid: $dx=4\text{mm}$, $dy=4\text{mm}$, $dz=1.4\text{mm}$

Reference Value = 2.248 V/m ; Power Drift = -0.17 dB

Peak SAR (extrapolated) = 0.0660 W/kg

SAR(1 g) = 0.012 W/kg ; SAR(10 g) = 0.00358 W/kg

Maximum value of SAR (measured) = 0.0312 W/kg

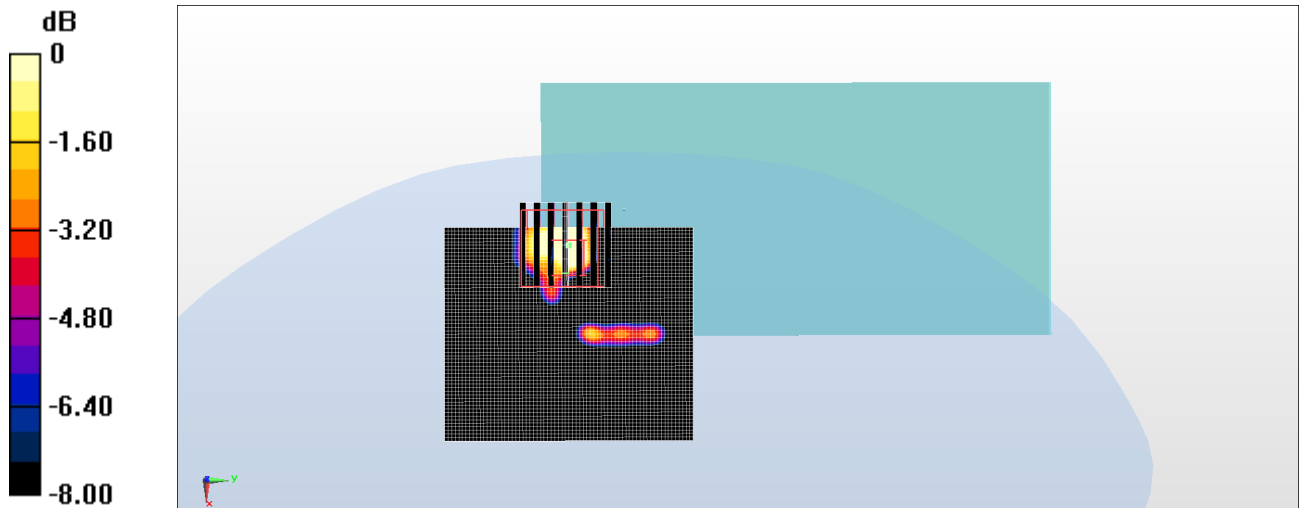

0 dB = 0.0312 W/kg = -15.06 dBW/kg

#08_WLAN5GHz_802.11n-HT40 MCS0_Right Side_10mm_Ch38;Ant 1

Communication System: 802.11n ; Frequency: 5190 MHz;Duty Cycle: 1:1.114

Medium: MSL_5G_180731 Medium parameters used: $f = 5190$ MHz; $\sigma = 5.155$ S/m; $\epsilon_r = 47.263$; $\rho = 1000$ kg/m³

Ambient Temperature : 23.2 °C ; Liquid Temperature : 22.2 °C

DASY5 Configuration

- Probe: EX3DV4 - SN3925;ConvF(4.44, 4.44, 4.44) @ 5190 MHz;Calibrated: 2018/5/31
- Sensor-Surface: 1.4mm (Mechanical Surface Detection)
- Electronics: DAE4 Sn854; Calibrated: 2018/6/14
- Phantom: SAM_Right; Type: QD000P40CD; Serial: S/N:1796
- Measurement SW: DASY52, Version 52.10 (1); SEMCAD X Version 14.6.11 (7439)

Area Scan (81x121x1): Interpolated grid: dx=1.000 mm, dy=1.000 mm

Maximum value of SAR (interpolated) = 0.0541 W/kg

Zoom Scan (7x7x7)/Cube 0: Measurement grid: dx=4mm, dy=4mm, dz=1.4mm

Reference Value = 1.307 V/m; Power Drift = -0.13 dB

Peak SAR (extrapolated) = 0.0900 W/kg

SAR(1 g) = 0.019 W/kg; SAR(10 g) = 0.00607 W/kg

Maximum value of SAR (measured) = 0.0538 W/kg

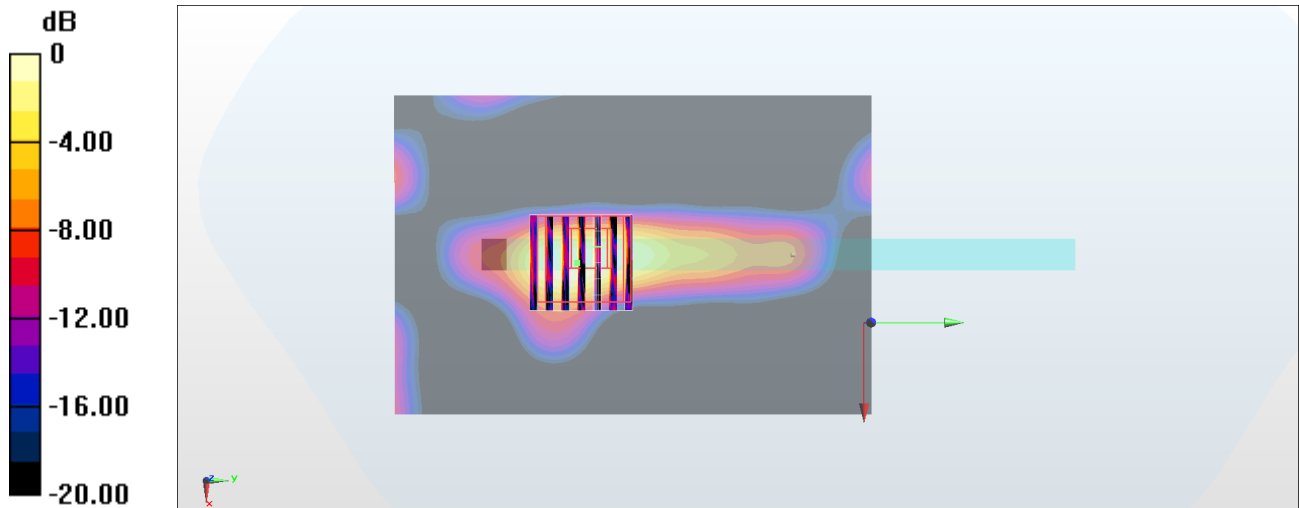

0 dB = 0.0538 W/kg = -12.69 dBW/kg

#09_WLAN5GHz_802.11n-HT40 MCS0_Back_10mm_Ch151;Ant 1

Communication System: 802.11n ; Frequency: 5755 MHz;Duty Cycle: 1:1.114

Medium: MSL_5G_180731 Medium parameters used : $f = 5755$ MHz; $\sigma = 5.881$ S/m; $\epsilon_r = 46.383$; $\rho = 1000$ kg/m³

Ambient Temperature : 23.2 °C ; Liquid Temperature : 22.2 °C

DASY5 Configuration

- Probe: EX3DV4 - SN3925;ConvF(4.17, 4.17, 4.17) @ 5755 MHz;Calibrated: 2018/5/31
- Sensor-Surface: 1.4mm (Mechanical Surface Detection)
- Electronics: DAE4 Sn854; Calibrated: 2018/6/14
- Phantom: SAM_Right; Type: QD000P40CD; Serial: S/N:1796
- Measurement SW: DASY52, Version 52.10 (1); SEMCAD X Version 14.6.11 (7439)

Area Scan (61x71x1): Interpolated grid: dx=1.000 mm, dy=1.000 mm

Maximum value of SAR (interpolated) = 0.174 W/kg

Zoom Scan (7x7x7)/Cube 0: Measurement grid: dx=4mm, dy=4mm, dz=1.4mm

Reference Value = 3.876 V/m; Power Drift = -0.17 dB

Peak SAR (extrapolated) = 0.188 W/kg

SAR(1 g) = 0.033 W/kg; SAR(10 g) = 0.00854 W/kg

Maximum value of SAR (measured) = 0.0859 W/kg

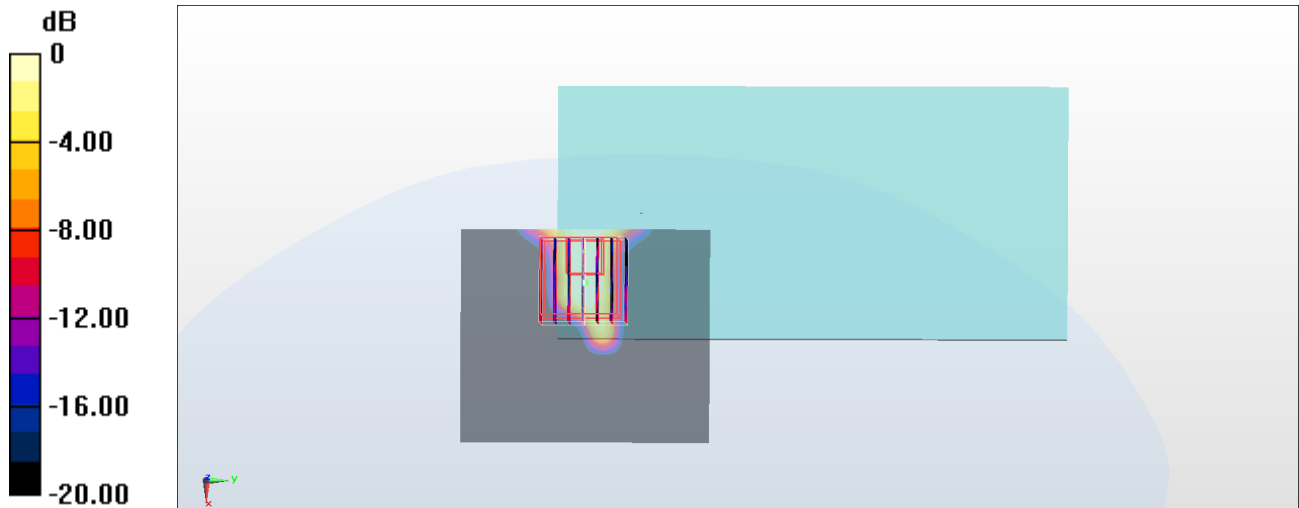

0 dB = 0.0859 W/kg = -10.66 dBW/kg

#10_WLAN5GHz_802.11n-HT40 MCS0_Right Side_10mm_Ch151;Ant 1

Communication System: 802.11n ; Frequency: 5755 MHz;Duty Cycle: 1:1.114

Medium: MSL_5G_180731 Medium parameters used : $f = 5755$ MHz; $\sigma = 5.881$ S/m; $\epsilon_r = 46.383$; $\rho = 1000$ kg/m³

Ambient Temperature : 23.2 °C ; Liquid Temperature : 22.2 °C

DASY5 Configuration

- Probe: EX3DV4 - SN3925;ConvF(4.17, 4.17, 4.17) @ 5755 MHz;Calibrated: 2018/5/31
- Sensor-Surface: 1.4mm (Mechanical Surface Detection)
- Electronics: DAE4 Sn854; Calibrated: 2018/6/14
- Phantom: SAM_Right; Type: QD000P40CD; Serial: S/N:1796
- Measurement SW: DASY52, Version 52.10 (1); SEMCAD X Version 14.6.11 (7439)

Area Scan (81x121x1): Interpolated grid: dx=1.000 mm, dy=1.000 mm

Maximum value of SAR (interpolated) = 0.0577 W/kg

Zoom Scan (7x7x7)/Cube 0: Measurement grid: dx=4mm, dy=4mm, dz=1.4mm

Reference Value = 2.174 V/m; Power Drift = -0.12 dB

Peak SAR (extrapolated) = 0.180 W/kg

SAR(1 g) = 0.017 W/kg; SAR(10 g) = 0.00523 W/kg

Maximum value of SAR (measured) = 0.0546 W/kg

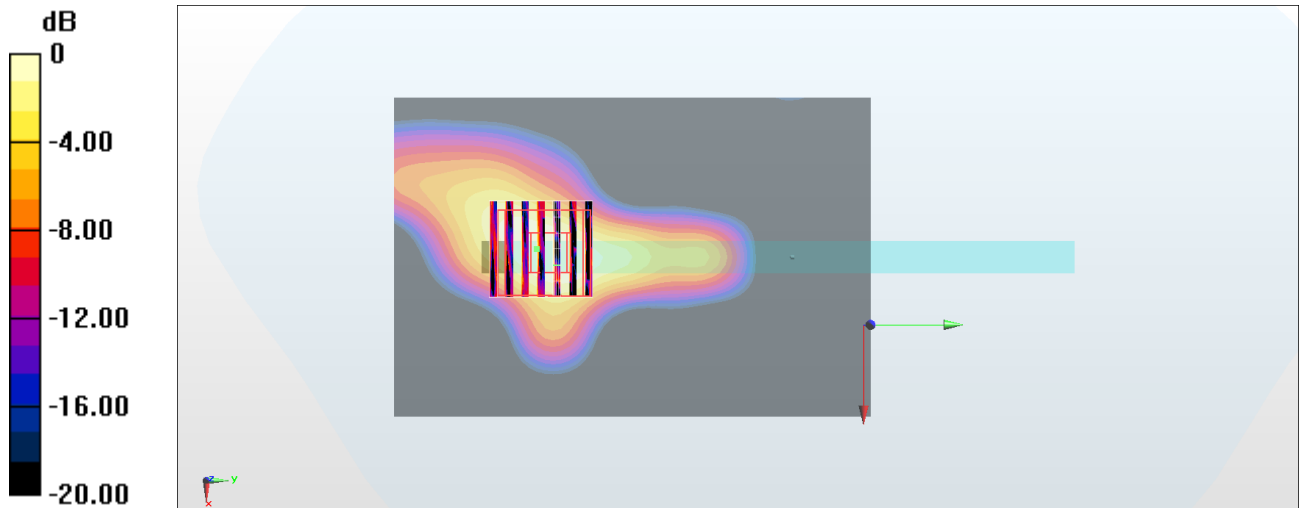

0 dB = 0.0546 W/kg = -12.63 dBW/kg

#11_WLAN2.4GHz_802.11b 1Mbps_Back_0mm_Ch1;Ant 1

Communication System: 802.11b; Frequency: 2412 MHz; Duty Cycle: 1:1

Medium: MSL_2450_180730 Medium parameters used: $f = 2412$ MHz; $\sigma = 1.944$ S/m; $\epsilon_r = 52.077$; $\rho = 1000$ kg/m³

Ambient Temperature : 23.1 °C; Liquid Temperature : 22.1 °C

DASY5 Configuration

- Probe: EX3DV4 - SN3925; ConvF(7.63, 7.63, 7.63) @ 2412 MHz; Calibrated: 2018/5/31
- Sensor-Surface: 1.4mm (Mechanical Surface Detection)
- Electronics: DAE4 Sn854; Calibrated: 2018/6/14
- Phantom: SAM_Right; Type: QD000P40CD; Serial: S/N:1796
- Measurement SW: DASY52, Version 52.10 (1); SEMCAD X Version 14.6.11 (7439)

Area Scan (81x71x1): Interpolated grid: dx=1.200 mm, dy=1.200 mm

Maximum value of SAR (interpolated) = 0.0316 W/kg

Zoom Scan (8x7x7)/Cube 0: Measurement grid: dx=5mm, dy=5mm, dz=5mm

Reference Value = 2.996 V/m; Power Drift = -0.07 dB

Peak SAR (extrapolated) = 0.0430 W/kg

SAR(1 g) = 0.017 W/kg; SAR(10 g) = 0.00916 W/kg

Maximum value of SAR (measured) = 0.0276 W/kg

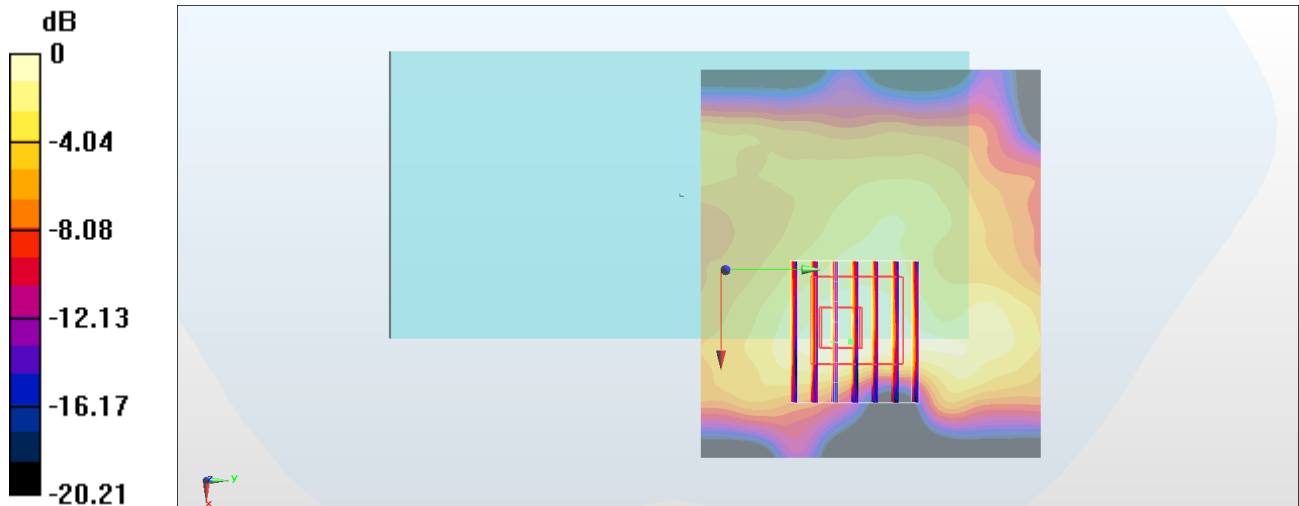

0 dB = 0.0276 W/kg = -15.59 dBW/kg

#12_WLAN5GHz_802.11n-HT40 MCS0_Back_10mm_Ch62;Ant 1

Communication System: 802.11n ; Frequency: 5310 MHz;Duty Cycle: 1:1.114

Medium: MSL_5G_180731 Medium parameters used: $f = 5310$ MHz; $\sigma = 5.307$ S/m; $\epsilon_r = 47.072$; $\rho = 1000$ kg/m³

Ambient Temperature : 23.2 °C ; Liquid Temperature : 22.2 °C

DASY5 Configuration

- Probe: EX3DV4 - SN3925;ConvF(4.44, 4.44, 4.44) @ 5310 MHz;Calibrated: 2018/5/31
- Sensor-Surface: 1.4mm (Mechanical Surface Detection)
- Electronics: DAE4 Sn854; Calibrated: 2018/6/14
- Phantom: SAM_Right; Type: QD000P40CD; Serial: S/N:1796
- Measurement SW: DASY52, Version 52.10 (1); SEMCAD X Version 14.6.11 (7439)

Area Scan (61x71x1): Interpolated grid: dx=1.000 mm, dy=1.000 mm

Maximum value of SAR (interpolated) = 0.0906 W/kg

Zoom Scan (7x7x7)/Cube 0: Measurement grid: dx=4mm, dy=4mm, dz=1.4mm

Reference Value = 2.082 V/m; Power Drift = -0.03 dB

Peak SAR (extrapolated) = 0.0900 W/kg

SAR(1 g) = 0.011 W/kg; SAR(10 g) = 0.00268 W/kg

Maximum value of SAR (measured) = 0.0362 W/kg

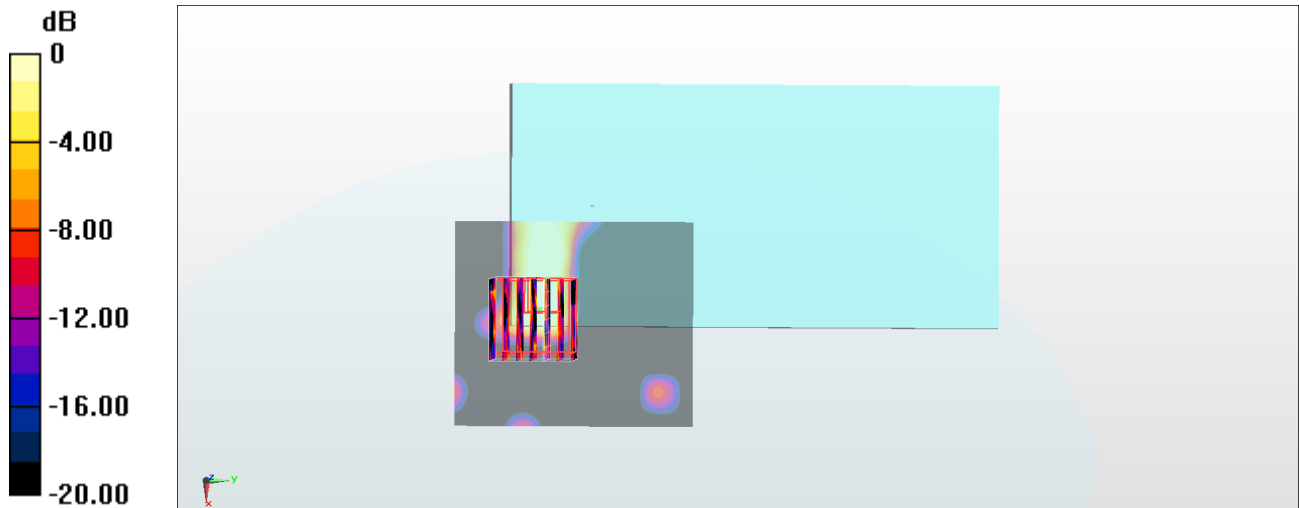

0 dB = 0.0362 W/kg = -14.41 dBW/kg

#13_WLAN5GHz_802.11n-HT40 MCS0_Back_10mm_Ch102;Ant 1

Communication System: 802.11n ; Frequency: 5510 MHz;Duty Cycle: 1:1.114

Medium: MSL_5G_180731 Medium parameters used: $f = 5510 \text{ MHz}$; $\sigma = 5.557 \text{ S/m}$; $\epsilon_r = 46.761$; $\rho = 1000 \text{ kg/m}^3$

Ambient Temperature : $23.2 \text{ }^\circ\text{C}$; Liquid Temperature : $22.2 \text{ }^\circ\text{C}$

DASY5 Configuration

- Probe: EX3DV4 - SN3925;ConvF(4.08, 4.08, 4.08) @ 5510 MHz;Calibrated: 2018/5/31
- Sensor-Surface: 1.4mm (Mechanical Surface Detection)
- Electronics: DAE4 Sn854; Calibrated: 2018/6/14
- Phantom: SAM_Right; Type: QD000P40CD; Serial: S/N:1796
- Measurement SW: DASY52, Version 52.10 (1); SEMCAD X Version 14.6.11 (7439)

Area Scan (61x71x1): Interpolated grid: $dx=1.000 \text{ mm}$, $dy=1.000 \text{ mm}$

Maximum value of SAR (interpolated) = 0.144 W/kg

Zoom Scan (7x7x7)/Cube 0: Measurement grid: $dx=4\text{mm}$, $dy=4\text{mm}$, $dz=1.4\text{mm}$

Reference Value = 2.681 V/m ; Power Drift = -0.06 dB

Peak SAR (extrapolated) = 0.162 W/kg

SAR(1 g) = 0.029 W/kg ; SAR(10 g) = 0.00827 W/kg

Maximum value of SAR (measured) = 0.0745 W/kg

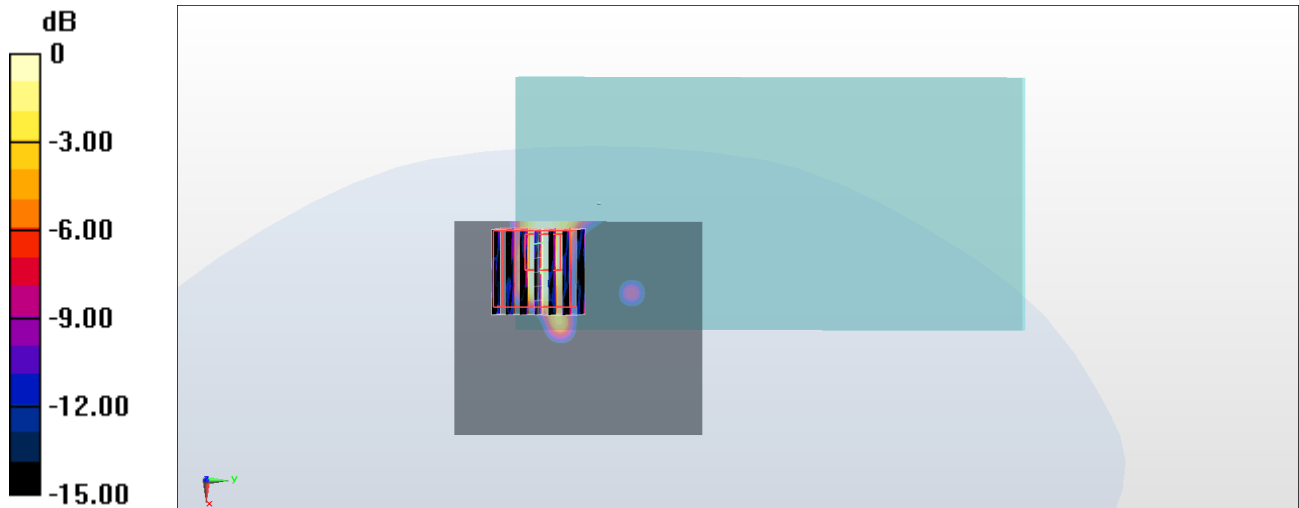

0 dB = 0.0745 W/kg = -11.28 dBW/kg

#14_WLAN5GHz_802.11n-HT40 MCS0_Back_10mm_Ch151;Ant 1

Communication System: 802.11n ; Frequency: 5755 MHz;Duty Cycle: 1:1.114

Medium: MSL_5G_180731 Medium parameters used : $f = 5755$ MHz; $\sigma = 5.881$ S/m; $\epsilon_r = 46.383$; $\rho = 1000$ kg/m³

Ambient Temperature : 23.2 °C ; Liquid Temperature : 22.2 °C

DASY5 Configuration

- Probe: EX3DV4 - SN3925;ConvF(4.17, 4.17, 4.17) @ 5755 MHz;Calibrated: 2018/5/31
- Sensor-Surface: 1.4mm (Mechanical Surface Detection)
- Electronics: DAE4 Sn854; Calibrated: 2018/6/14
- Phantom: SAM_Right; Type: QD000P40CD; Serial: S/N:1796
- Measurement SW: DASY52, Version 52.10 (1); SEMCAD X Version 14.6.11 (7439)

Area Scan (61x71x1): Interpolated grid: dx=1.000 mm, dy=1.000 mm

Maximum value of SAR (interpolated) = 0.174 W/kg

Zoom Scan (7x7x7)/Cube 0: Measurement grid: dx=4mm, dy=4mm, dz=1.4mm

Reference Value = 3.876 V/m; Power Drift = -0.17 dB

Peak SAR (extrapolated) = 0.188 W/kg

SAR(1 g) = 0.033 W/kg; SAR(10 g) = 0.00854 W/kg

Maximum value of SAR (measured) = 0.0859 W/kg

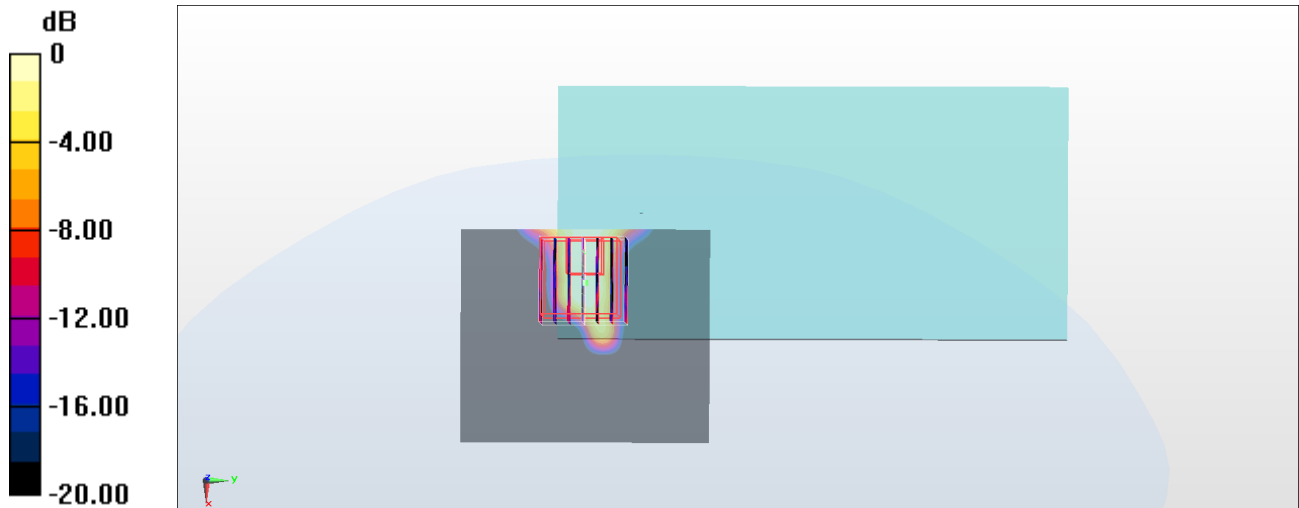

0 dB = 0.0859 W/kg = -10.66 dBW/kg