

Label Artwork and location

Each equipment covered in the certification for equipment authorization shall bear a label listing as the following:

- 1) **An FCC ID**, which should be printed in the following format with legible lettering. Eight point type is acceptable.

FCC ID: 2ALB6-KMNMBLE04

- "FCC ID" - in capital letters on a single line.
- 2ALB6** - your grantee code as assigned by the FCC (may be three or five).
- KMNMBLE04** - up to 14 alphanumeric characters you select. Dash or hyphen (-) may be used. No spaces are allowed.

2) Label artwork and location

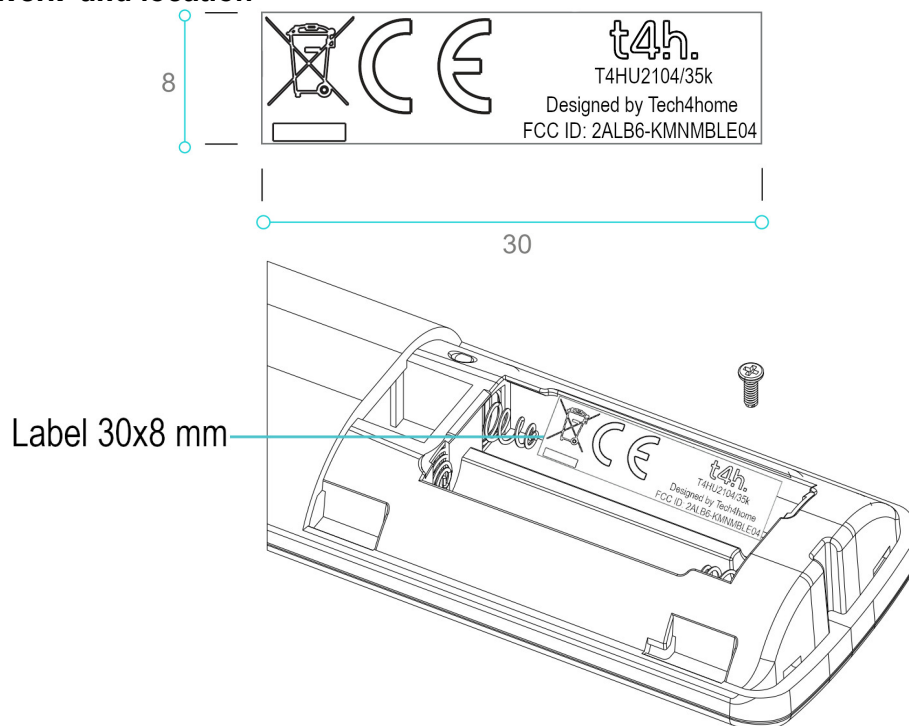

Note 1: The label shall not be a stick-on paper label. The label on these products shall be permanently affixed to the product and shall be readily visible to the purchaser at the time of purchase. "Permanently affixed" means that the label is etched, engraved, stamped, silkscreened, indelibly printed, or otherwise permanently marked on a permanently attached part of the equipment or on a nameplate of metal, plastic, or other material fastened to the equipment by welding, riveting, or a permanent adhesive. The label must be designed to last the expected lifetime of the equipment in the environment in which the equipment may be operated and must not be readily detachable.

Note 2: Label dimensions in millimeters.

Note 3: Above labelling example is for reference only, may have some differences with to actual product.