

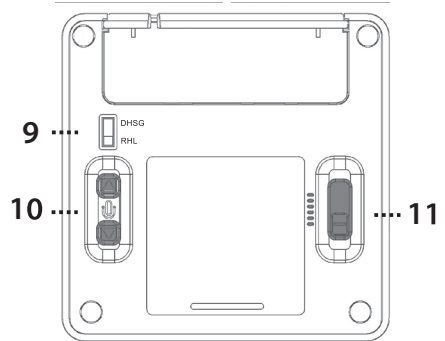

## A. Telephone/Bluetooth base station

1. Battery Indicator
2. Registration button
3. Bluetooth Button
4. Telephone (TEL) button
5. Online indicator
6. Power socket
7. Telephone connector ('Tel' port)
8. Handset connector
9. EHS Selection switch
10. Microphone volume up/down
11. Wiring switch

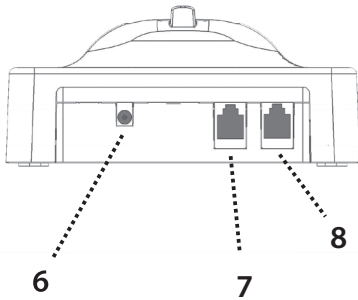
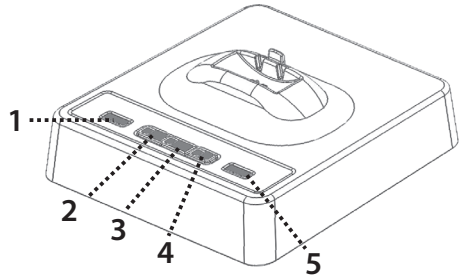

## B. IPN Monaural / IPN Binaural

1. Receive volume up/down
2. Mute
3. Headset ON/OFF
4. Noise cancelling boom
5. Battery

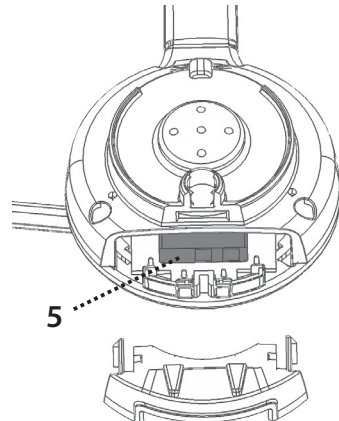
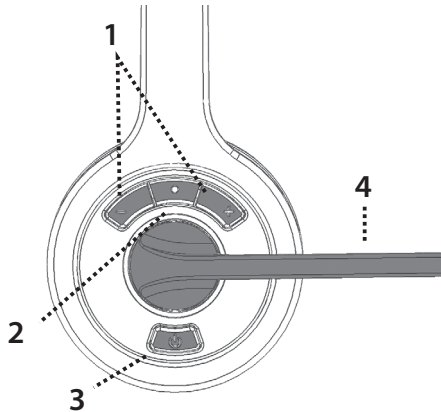
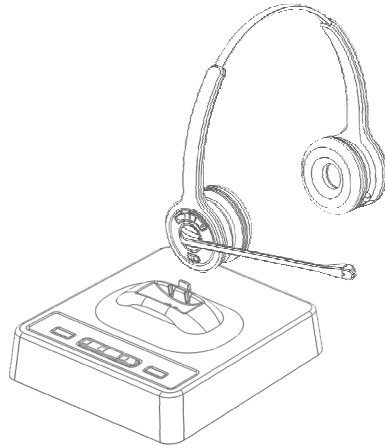

## **Contents:**

<b>1. Product description</b>	<b>5</b>
<b>2. Setup</b>	<b>6</b>
2.1 Connecting to a telephone or terminal with a headset port	6
2.2 Connection to a telephone or terminal without a headset port	6
2.3 Connecting to a Bluetooth device	7
2.4 Wearing style	7
<b>3. Operation</b>	<b>8</b>
3.1 Making and receiving calls	8
3.1.1 Making an outgoing call in telephone mode	8
3.1.2 Receiving an incoming call in telephone mode	8
3.1.3 Making or receiving a bluetooth cali	9
3.2 Adjusting the ring volume	9
3.3 Muting the headset microphone	9
3.4 Headset transmitting volume setting	9
3.5 Adjusting headset receive volume	10
3.6 Out of range and reconnection	10
3.7 Battery level indication	10
3.8 Switching Off Auto Pickup Mode (Telephone only base station)	10
3.9 Making a conference call	11
3.10 Registering headsets to the base	11
3.11 Using multiple headsets	12
3.12 Overview of audio signals	13
<b>4. Troubleshooting</b>	<b>14</b>

## 1. Product description

The IPN W99x DECT is a fully wireless headset solution offering the user the ability to work 'handsfree' with true wireless mobility.

Main features:

- DECT wireless headset solution
- Universal headset base
- Up to 9 hours talk time without recharging
- Eco-Low Radiation Dect with dynamic power adjustment
- Auxiliary port for connecting handset lifter or electronic hookswitch device
- Noise cancelling microphone for reduced background noise
- Secure high quality audio
- Receive volume control on headset
- Mute button on headset
- Talk button with LED on headset
- Magnetic charging unit
- Operating Range up to 400m/1300 ft (Over-the-ear headset up to 300m)
- 'Out of range' warning
- DECT 6.0/GAP compatible
- DHSG protocol
- Bluetooth device connectivity
- Three way conferencing by connection of additional headset

## 2. Setup

- Connect the power adaptor supplied with the product to the base unit.
- The base power LED with light.

NOTE: The first time you use your headset, it is recommended that the headset is charged for a minimum of 4 hours before use.

### 2.1 Connecting to a telephone or terminal with a headset port

- Using the headset cord supplied with the product, connect the 'Tel' port on headset base with the headset port on your telephone.
- Use the power adaptor supplied with the product to connect the headset base to a power socket.
- You may need to adjust the wiring switch that is located on the bottom of the headset Base to find the correct wiring for your device.

### 2.2 Connecting to a telephone or terminal without a headset port

- Using the headset cord supplied with the product, connect the 'Tel' port on headset base with the 'handset' port on your telephone.
- Connect the telephone handset cord to the handset port on the headset base.
- Use the power adaptor supplied with the product to connect the headset base to a power socket.
- You may need to adjust the wiring switch that is located on the bottom of the headset base to find the correct wiring for your device.

### 2.3 Connecting to a Bluetooth device

- Hold down the Bluetooth button on the base for three (3) seconds until the LED flashes
- On the *Bluetooth*® device, turn on the *Bluetooth*® feature. The *Bluetooth*® feature is usually found in the settings menu
- Select 'DECT Headset' from the device list. Once paired, the LED will stop flashing.

### 2.4 Wearing Style

- The IPN W99x series is available in two headset variants:
- W990 IPN Over-the-head monaural
- W995 IPN Over-the-head binaural

To replace the ear cushion of the IPN Over-the-head monaural or binaural, put your thumb on the top of the speaker and carefully pull the ear cushion at the bottom towards you.

### **3. Operation**

#### **3.1 Making and Receiving Calls**

##### **3.1.1 Making an outgoing call in Telephone mode**

- Ensure that the 'TEL' button on top of the headset base is selected.
- Lift the headset from the base to start a call. If you are already wearing the headset, press the headset's 'ON/OFF' button. The base 'Online Indicator' LED will light. If a handset Lifter or Electronic Hookswitch device is connected to the headset base, the line will be seized. Otherwise, you will also need to activate the Headset port via your telephone terminal.
- Dial the telephone number on the telephone terminal
- After finishing the call, replace the headset on the base or press the ON/OFF button to disconnect. The 'Online indicator' LED will turn off.

##### **3.1.2 Receive an incoming call in Telephone mode.**

- If there is an incoming call from the telephone line and the headset base is connected to a handset lifter or Electronic Hook switch device, the 'TEL' LED and 'headset' LED will flash, also a ring tone will be heard on the headset.
- Lift the headset from the base to answer the call. If you are already wearing the headset press the headset's 'ON/OFF' button . The base 'online indicator' LED will light. If a handset Lifter or Electronic Hookswitch device is connected to the headset base, the line will be seized. Otherwise, you will also need to activate the headset port via your telephone terminal.
- To end the call, replace the headset on the base or press the headset ON/OFF button.



### 3.1.3 Making or receiving a Bluetooth call

- Ensure that the 'Bluetooth' button on top of the headset base is selected.
- Lift the headset from the base or press the headset's ON/OFF button if you are already wearing it and the base 'On line indicator' LED will light.
- Make or answer the call on your bluetooth device ensuring that the DECT Headset is selected as your audio device
- After finishing your call, press the ON/OFF button on the headset or end call button on the bluetooth device to disconnect. The base 'Online indicator' LED will turn off.

### 3.2 Adjusting the Ringing Volume

When the headset is ringing to indicated an incoming call, you can adjust the ring volume using the volume control buttons located on the headset.

### 3.3 Muting The Headset Microphone

To mute the headset microphone when on a call, press the 'Mute' button on the headset. While the headset is in Mute mode, a short beep will be heard on the headset every 8 seconds. Press the 'Mute' button again to release the mute.

### 3.4 Headset transmitting volume setting

You can adjust the transmit volume of the headset by using the two buttons located on the bottom of the headset base.

### 3.5 Adjusting Headset Receive Volume

Use the volume control buttons on the headset to adjust the receive volume on your headset. You will hear a beep sound for each volume step Up or Down.

### 3.6 Out of range and Reconnection

You will hear a warning tone in the headset when you walk out of range of the base. The headset will be disconnected from the base and the call will be automatically placed on hold. If you move back inside the range of the base the headset will automatically reconnect.

### 3.7 Battery Level Indication

The four LED's (8) on the top of the headset base indicate the battery level of your headset.

Indication	Battery level
One LED flashing	< 20%
One LED on	20%-40%
Two LEDs on	40%-60%
Three LEDs on	60%-80%
Four LEDs on	80%-100%

### 3.8 Switching Off Auto Pickup Mode

The headset turns on automatically when taking the headset from the base. This function can be disabled. If the 'auto answer disable' button (2) is pressed, the LED will light and the headset auto answer mode will be disabled.

### 3.9 Making A Conference Call

Your IPN DECT Headset allows for a second headset to be temporarily connected to the base so that you can have a three way conference call.

- Setup the call using the primary headset unit.
- Once on the call, place the second IPN DECT headset unit on the base charger.
- After one second, the 'Online indicator' LED of the new headset will turn on and the base 'Online indicator' LED will flash to indicate the headset is registering with base unit.
- Once the registering has completed, the base 'Online indicator' LED will stop flashing and the additional headset LED will flash.
- Once the registration has completed, a confirmation sound will be heard on the primary headset.
- Lift the additional headset from the base and it will enter talk mode.

NOTE: The additional headset will only remain registered to the base for the duration of the call. After the primary headset has ended the call, the unit will return to its normal state.

The IPN DECT headset also allows you to make a conference call between either your desk phone and the bluetooth device. To activate this option when on a call in any of the modes, hold down the function button for the mode you wish to conference in for four seconds. The LED's of the two modes will light together. If one of the buttons is pressed again this function will be turned off.

### 3.10 Registering headsets to the base

Up to three headsets can be registered permanently to the W9xx base. You can register a new headset unit to your base using the following procedure.

- Press and hold the 'TEL' or 'Registration' button on the headset base for five seconds to enter the registration mode. The 'TEL' LED will flash to indicate it is in registration mode.
- Press and hold the 'Headset ON/OFF' button on the headset for five seconds for the headset to enter registration mode.

- The headset will now be registered to the base which will take around 30 seconds. When the registration has completed, the base 'TEL' LED will stop flashing.

The additional 2 auxiliary headsets can be registered using the same procedure but instead of the 'TEL' button, use the microphone 'Up' button for headset 2 and the microphone 'Down' button for headset 3. These can be found on the underside of the headset base.

### 3.11 Using multiple headsets

If you have more than one headset registered to the W9xx base, the first headset to be turned on becomes the primary headset and takes control of the base. Another headset can then join and leave the call by the user pressing their headset buttons, but only the primary headset can end the call. NOTE: Only one of the two additional headsets can connect at any one time.

### 3.12 Overview of audio signals

Action	Audio indication
Low battery	2 rapid beeps (60 sec repeat)
Nearly out of range	2 beeps
Out of range	2 pitch tone
Back in range	4 rapid beeps
Receiver volume up/down	1 beep
Mute on	2 pitch tone (8 sec repeat)
Mute off	1 beep
Ringer (EH device)	Multi tone (2 sec repeat)

## 4. Troubleshooting

- Q. I have connected my headset base to my telephone terminal but the headset is not working.
- A. Make sure that the battery has been properly charged.
- Q. The headset is working but I cannot hear telephones calls correctly.
- A. Ensure that you have the correct wiring setting by adjusting the switch on the bottom of the headset base.
- Q. When the headset's ON/OFF button is pressed, the handset lifter lifts the handset but I cannot hear the call on the headset.
- A. Ensure that the headset base is connected to the telephone's handset port and not the headset port (If the telephone has one).

## Health and safety instructions

Please read the following safety and operational instructions before using your IPN headset product. Please keep these instructions for your reference. When using this product, these basic safety precautions and warnings should be followed to reduce the risk of fire, electric shock, injury to persons and damage to property.

### General

Operating, charging and storage temperature is 32°F to 104°F (0°C to 40°C).

### Warnings

- CHILDREN. Never allow children to play with the product – small parts may be a choking hazard.
- Plug the AC adapter into the outlet nearest the equipment that is easily accessible.
- To reduce the risk of electric shock, explosion or fire, use only the supplied charger or Class 2 AC adapter to charge the headset. Ensure that the voltage rating (e.g. 120V, 60 Hz) corresponds to the power supply you intend to use.
- For safety reasons always tie back long hair that might get caught in the headset.

- Do not disassemble the product or AC adapter as this may expose you to dangerous voltages or other risks. Incorrect reassembly can cause electric shock or fire when the product is subsequently used.
- Do not insert anything into the product because this may cause damage to the internal components or cause injury to you.
- Avoid contact with liquids. Do not locate this product near water, for example, near a bathtub, or sink, in a wet basement, or near a swimming pool.
- Discontinue use of product and contact IPN Headsets if the product overheats, has a damaged cord or plug, if the product has been dropped or damaged, or if the product has come into contact with liquids.
- This product should never be placed over or near a heat register and should not be placed in locations without which do not have proper ventilation.
- If you experience a skin irritation after using this product, discontinue use and contact IPN Headsets.
- Exposure to high volume sound levels or excessive sound pressure may cause temporary or permanent damage to your hearing. Although there is no single volume setting that is appropriate for everyone, you should always use your headset with the volume set at moderate levels and avoid prolonged exposure to high volume sound levels. The louder the volume, the less time is required before your hearing could be affected. You may experience different sound levels when using your headset with different devices. The device you use and its settings affect the level of sound you hear. If you experience hearing discomfort, you should stop listening to the device through your headset and have your hearing checked by your doctor.

To protect your hearing, some hearing experts suggest you:

1. Set the volume control in a low position before putting your headset on your ears and use as low volume as possible.
2. Avoid turning up the volume to block out noisy surroundings. Whenever possible, use your headset in a quiet environment with low background noise.
3. Limit the amount of time you use headsets at high volume levels.
4. Turn the volume down if the sound from the headset prevent you from hearing people speaking near you.

To avoid the risk of electric shock, explosion, fire or leakage of corrosive or toxic chemicals, please observe the following charging and battery warnings:

### **Charging warnings**

- Use only the charger supplied by IPN Headsets to charge the product. Do not use the charger for any other purpose. Ensure that the voltage rating corresponds to the power supply you intend to use.
- Charge the headset according to the instructions supplied with the unit.
- Plug the AC adapter or charger into an outlet that is near the equipment and will be easily accessible.
- Never charge the battery where the temperature may fall below 0°C (32°F) or rise above 40°C (104°F) – for example in an unattended motor vehicle.
- Avoid charging the battery while it is unattended.

### **Headset battery warnings**

The headset is equipped with a replaceable battery. To reduce the risk of fire or injury to persons read and follow these instructions.

Do not attempt to open battery in a fire. The battery may explode. Check the local laws for disposal instructions.

Do not open or mutilate the battery. There may be corrosive materials which can cause damage to eyes or skin and may be toxic if swallowed.

Charge the headset according to the instructions supplied with the headset.

RECYCLING: the battery used in your headset must be recycled or disposed of properly. Contact your local recycling centre for proper disposal of your headset.



## IMPORTANT SAFETY INSTRUCTIONS

Do not use this equipment in places where volatile or explosive materials may be present. This equipment will be inoperable if mains power fails. For indoor use only.

When using your telephone equipment, basic safety precautions should always be followed to reduce the risk of fire, electric shock and injury to persons, including the following:

- Do not use this product near water, for example a bath tub, wash bowl, kitchen sink or laundry tub, in a wet basement or near a swimming pool.
- Avoid using a telephone (other than a cordless type) during an electrical storm. There may be a remote risk or electric shock from lightning.
- Do not use the telephone to report a gas leak in the vicinity of the leak.
- Use only the power cord and batteries indicated in this manual. Do not dispose of batteries in a fire. They may explode. Check with local codes for possible special disposal instructions.

### CAUTION:

Risk of explosion if battery is replaced by an incorrect type.

**Dispose of used batteries according to instructions.**

**Use only with (IPN W990 & W995) (3.7 V, 200 mAh Li-ion rechargeable battery).**

Supplied adaptor with ferrite must be used with this device to ensure compliance with the class B FCC limits.

This equipment complies with Part 68 of the FCC rules and the requirements adopted by the ACTA. On the bottom of this equipment is a label that contains, among other information, a product identifier in the format US: AAAEQ##TXXXX. If requested, this number must be provided to the telephone company.

An applicable certification jacks Universal Service Order Codes (USOC) for the equipment is provided (i.e RJ9) in the packaging with each piece of approved terminal equipment. A plug and jack used to connect this equipment to the premises wiring and telephone network must comply with the applicable FCC Part 68 rules and requirements adopted by the ACTA. A compliant telephone cord and modular plug is provided with this product. It is designed to be connected to a compatible modular jack that is also compliant.

See installation instructions for details.

If this equipment IPN W9xx causes harm to the telephone network, the telephone company will notify you in an advance that temporary discontinuation of service may be required. But if advance notice isn't practical, the telephone company will notify the customer as soon as possible. Also, you will be advised of your rights to file a complaint with the FCC if you believe it is necessary.

The telephone company may make changes in its facilities, equipment, operations or procedures that could affect the operation of the equipment. If this happens the telephone company will provide advance notice in order for you to make necessary modifications to maintain uninterrupted service.

Should you experience trouble with this equipment in the US, please contact:

**Headsets.com, Inc.**

**211 Austin Street**

**San Francisco, CA 94109**

**Phone: 1-800-HEADSETS (1-800-432-3738) Mon-Fri 6:00-4:30 Pacific Time**

**Website: [www.headsets.com](http://www.headsets.com)**

For repair or warranty information. If the equipment is causing harm to the telephone network, the telephone company may request that you disconnect the equipment until the problem is resolved. Please follow instructions for repairing if any (e.g battery replacement section) otherwise do not alternate of repair any parts of the device except specified.

I) Connection to party line service is subject to state tariffs. Contact the state public utility commission, public service commission or corporation commission for information.

II) **Notice:** If your home has specially wired alarm equipment connected to the telephone line, ensure the installation of this IPN W9xx does not disable your alarm equipment. If you have questions about what will disable alarm equipment, consult your telephone company or a qualified installer. This equipment is hearing aid compatible.

**Save these instructions**

## Europe Declaration

This product is CE marked according to the provisions of the R and TTE directive (99/5/EC). This product is in compliance with the essential requirements and other relevant provisions of the directive 1999/5/EC.

Safety:	EN60950-1:2006+A11:2009+A12:2011+A2:2013
EMC:	EN301489-6 V2.2.0(2017-03)
	EN301489-1 V2.2.0(2017-03)
	EN55032:2015
	EN55035:2017
	EN61000-3-2:2014
	EN61000-3-3:2013
RF:	EN301406 V2.2.2(2016-09)
RF Safety:	EN50663:2017
	EN62479:2010

Only to be used together with the delivered certified AC mains adaptor with a GS mark. Within the EU this product is intended to be used in Austria, Belgium, Denmark, Finland, France, Germany, Greece, Ireland, Italy, Luxembourg, The Netherlands, Portugal, Spain, Sweden, United Kingdom, Cyprus, Czech Republic, Estonia, Hungary, Latvia, Lithuania, Malta, Poland, Slovakia and Slovenia and within the EFTA in Iceland, Norway and Switzerland.

## **FCC Warning:**

This device complies with part 15 of the FCC Rules. Operation is subject to the following two conditions:

(1) This device may not cause harmful interference, and (2) this device must accept any interference received, including interference that may cause undesired operation. Any Changes or modifications not expressly approved by the party responsible for compliance could void the user's authority to operate the equipment.

Note: This equipment has been tested and found to comply with the limits for a Class B digital device, pursuant to part 15 of the FCC Rules. These limits are designed to provide reasonable protection against harmful interference in a residential installation. This equipment generates, uses and can radiate radio frequency energy and, if not installed and used in accordance with the instructions, may cause harmful interference to radio communications. However, there is no guarantee that interference will not occur in a particular installation. If this equipment does cause harmful interference to radio or television reception, which can be determined by turning the equipment off and on, the user is encouraged to try to correct the interference by one or more of the following measures:

- Reorient or relocate the receiving antenna.
- Increase the separation between the equipment and receiver.
- Connect the equipment into an outlet on a circuit different from that to which the receiver is connected.
- Consult the dealer or an experienced radio/TV technician for help.

## **FCC Exposure to Radio Frequency (RF) Signals**

### **For Handset**

This is a radio transmitter and receiver. It is designed and manufactured not to exceed the emission limits for exposure to radio frequency (RF) energy set by the Federal Communications Commission (FCC) of the U.S. Government. These limits are part of comprehensive guidelines and establish permitted levels of RF energy for the general population. The guidelines are based on the safety standards previously set by both U.S. and international standards bodies. These standards include a substantial safety margin designed to assure the safety of all persons, regardless of age and health. This device and its antenna must not be co-located or operating in conjunction with any other antenna or transmitter. This product has been shown to be capable of compliance for localized specific absorption rate (SAR) for uncontrolled environment/general population exposure limits specified in ANSI/IEEE Std. C95.1-1992 and had been tested in accordance with the measurement procedures specified in FCC/OET Bulletin 65 Supplement C (2001) and IEEE 1528.

### **For Base**

This equipment complies with FCC radiation exposure limits set forth for an uncontrolled environment. This equipment should be installed and operated with minimum distance 20cm between the radiator & your body.

This transmitter must not be co-located or operating in conjunction with any other antenna or transmitter.

## **ISED Warning:**

This device complies with ISED licence-exempt RSS standard(s). Operation is subject to the following two conditions:

- (1) this device may not cause interference, and
- (2) this device must accept any interference, including interference that may cause undesired operation of the device.

Le présent appareil est conforme aux CNR d'ISED applicables aux appareils radio exempts de licence. L'exploitation est autorisée aux deux conditions suivantes :

- (1) l'appareil ne doit pas produire de brouillage, et
- (2) l'utilisateur de l'appareil doit accepter tout brouillage radioélectrique subi, même si le brouillage est susceptible d'en compromettre le fonctionnement.

The device has been tested and compliance with SAR limits, user can obtain Canadian information of RF exposure and compliance

Le présent appareil est conforme. Après examen de ce matériel aux limites DAS et/ou aux limites d'intensité de champ RF, les utilisateurs peuvent sur l'exposition aux radiofréquences et la conformité and compliance d'acquérir

## **ISED Specific Absorption Rate (SAR) information**

### **For Headset**

SAR tests are conducted using standard operating positions accepted by the ISED with device transmitting at its highest certified power level in all tested frequency bands, although the SAR is determined at the highest certified power level, the actual SAR level of the device while operating can be well below the maximum value. Before a new model device is available for

sale to the public, it must be tested and certified to the ISEDC that it does not exceed the exposure limit established by the ISEDC, tests for each device are performed in positions and locations as required by the ISEDC. For body worn operation, this model device has been tested and meets the ISEDC RF exposure guidelines when used with an accessory designated for this product or when used with an accessory that contains no metal.

SAR l'utilisation des règles sma l'emplacement Le matériel de transmission et fonctionnant dans tous les essais à la certification, même si la puissance suprême a décidé le niveau, utilisation spécifique peut être très en deçà de la valeur de référence maximale.Types de matériel sont vendus au public un ancien, d'essai et de certification de l'exposition, limite maximum sma, chaque document et l'emplacement du matériel d'essai et conformément au document.Le modèle en physique, matériel d'essai et conforme aux directives d'exposition des radiofréquences sma quand une annexe désigné pour ce produit lors de leur utilisation ou des pièces de rechange ne contiennent pas de métal.

### **For Base**

This equipment complies with ISEDC radiation exposure limits set forth for an uncontrolled environment. This equipment should be installed and operated with minimum distance 20cm between the radiator& your body.

This transmitter must not be co-located or operating in conjunction with any other antenna or transmitter.

Cet équipement est conforme aux limites d'exposition aux radiations ISEDC définies pour un environnement non contrôlé. Cet équipement doit être installé et utilisé avec une distance minimale de 20 cm entre le radiateur et votre corps.

Cet émetteur ne doit pas être situé ou fonctionner conjointement avec une autre antenne ou un autre émetteur.

**CS-03:**

This product meets the applicable ISEDC technical specifications. / Le present matériel est conforme aux spécifications techniques applicables d'ISEDC.

The REN is an indication of the maximum number of terminals allowed to be connected to a telephone interface. The termination on an interface may consist of any combination of devices subject only to the requirement that the sum of the Ringer Equivalence Numbers of all the devices does not exceed five. / L'indice d'équivalence de la sonnerie (IES) sert à indiquer le nombre maximal de terminaux qui peuvent être raccordés à une interface téléphonique. La terminaison d'une interface peut consister en une combinaison quelconque de dispositifs, à la seule condition que la somme d'indices d'équivalence de la sonnerie de tous les dispositifs n'excède pas cinq.

**REN: 0.7**