



TEST REPORT

APPLICANT : Orchid Electronics Limited

PRODUCT NAME : DECT Base Antenna

MODEL NAME : OEL_ANT_001

TRADE NAME : N/A

BRAND NAME : N/A

STANDARD(S) : IEEE Std 149-2021

RECEIPT DATE : 2022-10-24

TEST DATE : 2022-10-25

ISSUE DATE : 2022-12-26

Edited by: *Fang Jinshan*
Fang Jinshan(Rapporteur)

Approved by: *Chi Shide*
Chi Shide(Supervisor)

NOTE: This document is issued by Shenzhen Morlab Communications Technology Co., Ltd., the test report shall not be reproduced except in full without prior written permission of the company. The test results apply only to the particular sample(s) tested and to the specific tests carried out which is available on request for validation and information confirmed at our website.





DIRECTORY

- 1. Technical Information3
- 1.1. Applicant and Manufacturer Information3
- 1.2. Equipment Under Test (EUT) Description3
- 2. Test Results 4
- 2.1. Applied Reference Documents4
- 2.2. Test Conditions 4
- 2.3. Measurement Uncertainty 4
- 2.4. Test Results 5
- Annex A Test Setup Photos6
- Annex B Figures7
- 1. 2D Radiation Pattern7
- 2. 3D Radiation Pattern8
- Annex C EUT Photos 10
- Annex D General Information12
- 1.1 Identification of the Responsible Testing Laboratory12
- 1.2 Identification of the Responsible Testing Location12
- 1.3 Test Equipments Utilized 12

Change History		
Version	Date	Reason for change
1.0	2022-12-26	First edition

1. Technical Information

Note: Provide by manufacturer.

1.1. Applicant and Manufacturer Information

Applicant:	Orchid Electronics Limited
Applicant Address:	Unit 702, 7/FI., One Hung To Road, Kwun Tong, Hong Kong
Manufacturer:	Oi Nan Technology Limited
Manufacturer Address:	4 Yin Sha Lu 2 Jie, Xia Bin, Cheung On, Dong Guan, Guangdong, China

1.2. Equipment Under Test (EUT) Description

Wireless Type	DECT 6.0
Frequency	N/A
IMEI	N/A
Sample No.	1#

Dimensions:

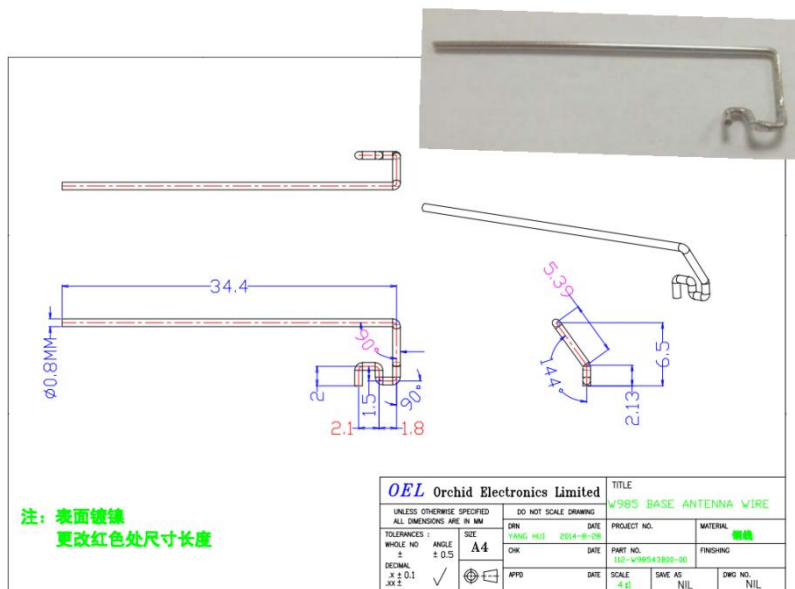

2. Test Results

2.1. Applied Reference Documents

Leading reference documents for testing:

No.	Identity	Document Title
1	IEEE Std 149-2021	IEEE Recommended Practice for Antenna Measurements

2.2. Test Conditions

Test Environment Conditions:

Relative Humidity:	25 ... 75 %
Temperature:	+10 °C to +30 °C

2.3. Measurement Uncertainty

The uncertainty is calculated using the methods suggested in the "Guide to the Expression of Uncertainty in Measurement" (GUM) published by ISO. When the test result is a critical value, we will use the measurement uncertainty give the judgment result based on the 95% Confidence intervals.

Item	Measurement Uncertainty(dB)
Gain	±0.5
VSWR	±0.2
Measurement Uncertainty(95% Confidence Interval) K=2	



2.4. Test Results

Frequency (MHz)	Gain(dBi)
1921.536	-2.84
1923.264	-2.79
1924.992	-2.71
1926.720	-2.63
1928.448	-2.62

Annex A Test Setup Photos

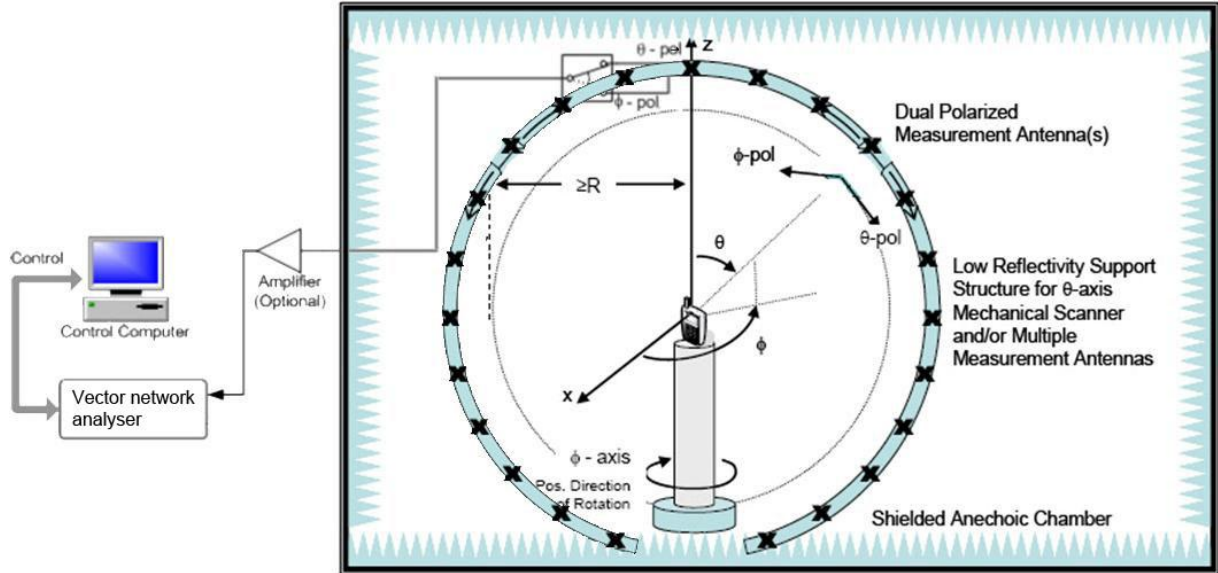

Annex B Figures

1. 2D Radiation Pattern

Phi=0°

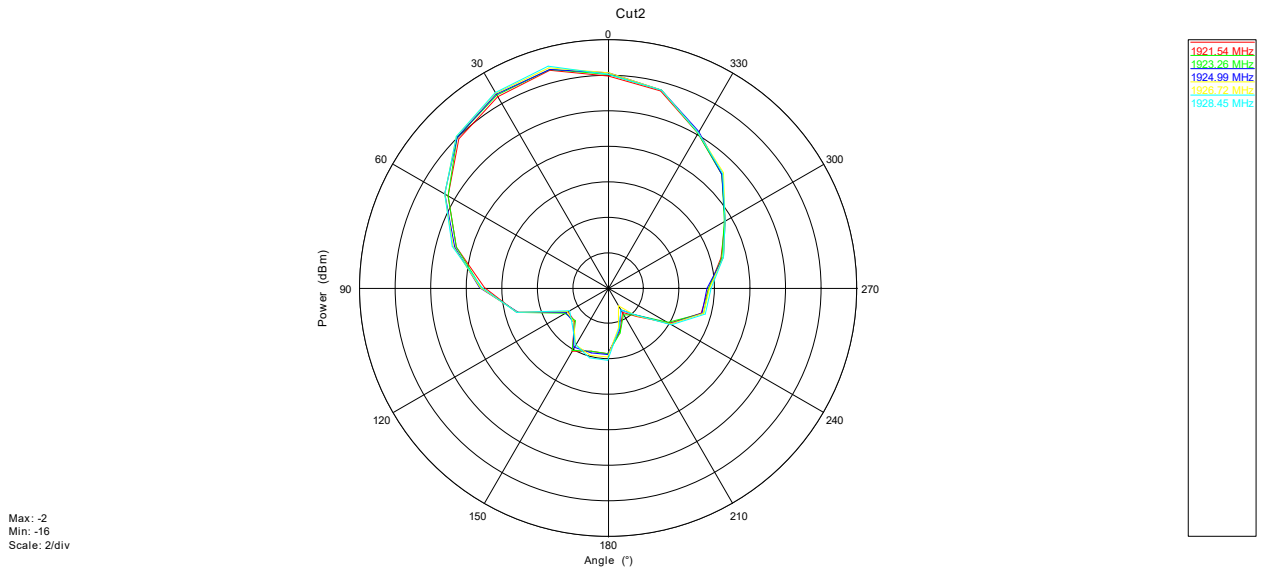

Phi=90°

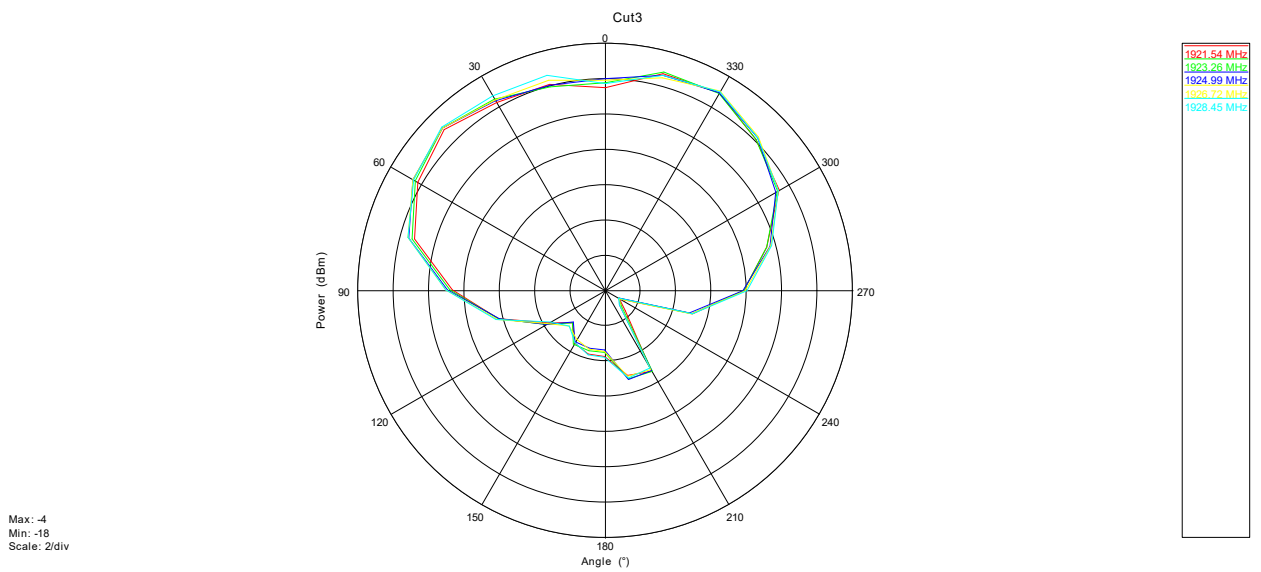



Theta=90°

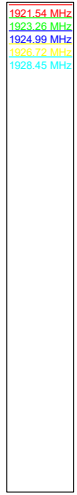
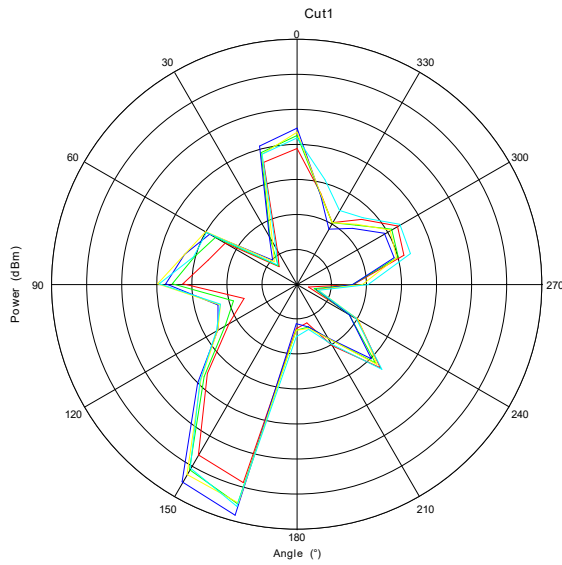

Max: -7.5
Min: -11
Scale: 0.5/div

2. 3D Radiation Pattern

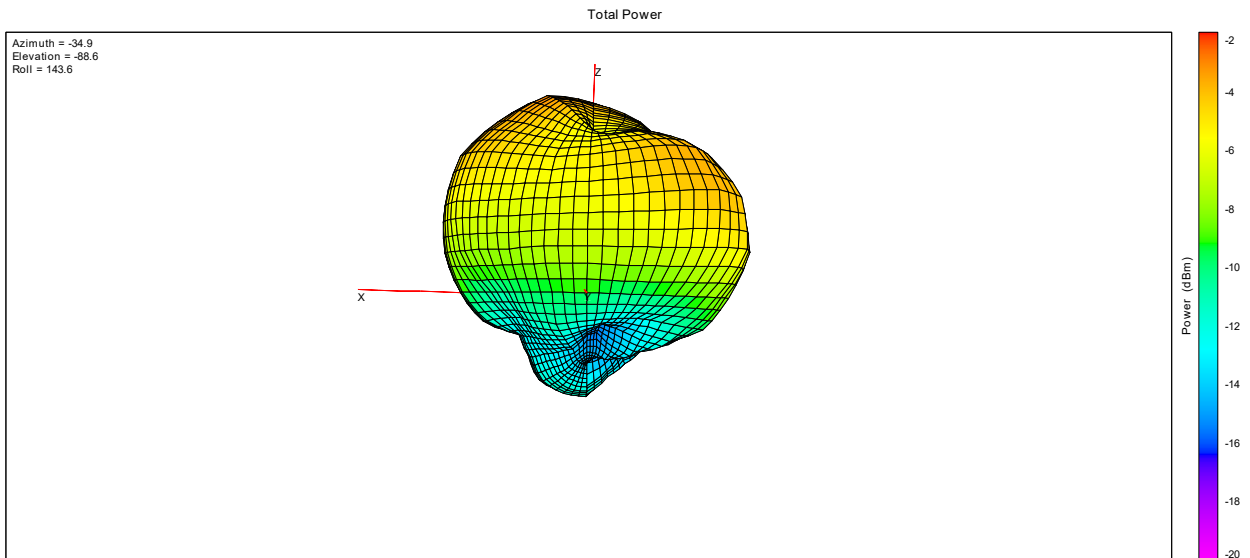

1921.536MHz

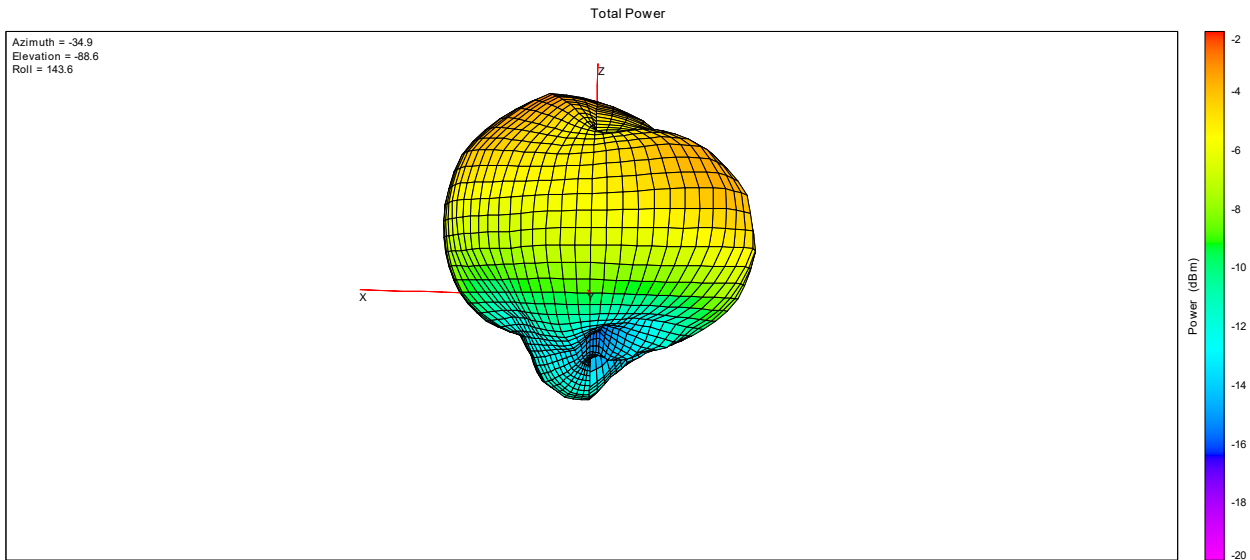

1924.992MHz

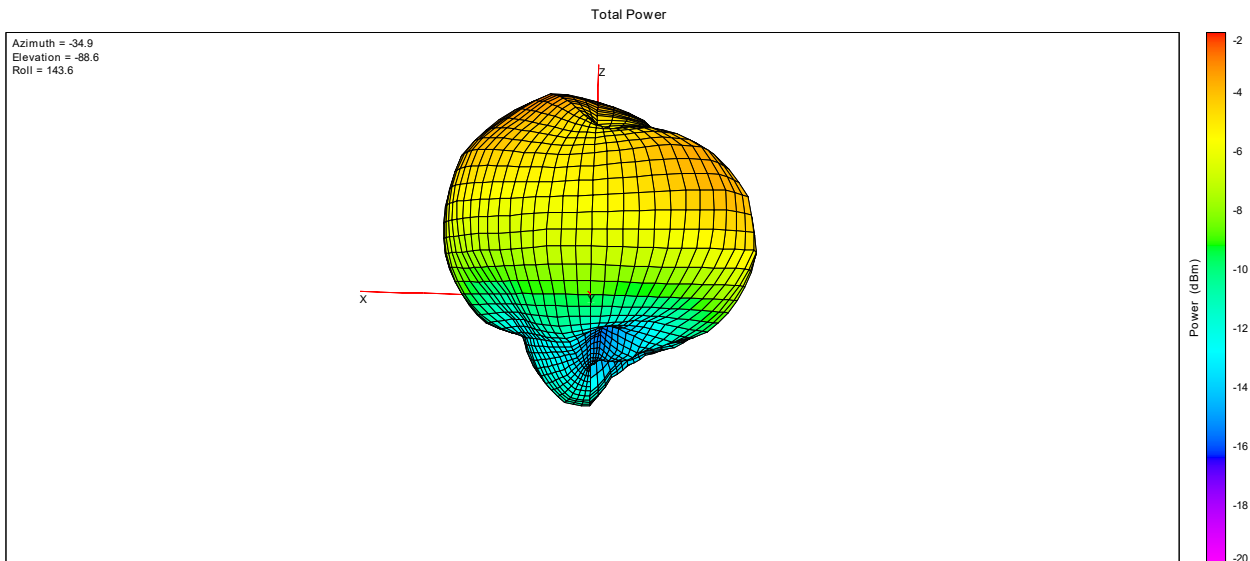

1928.448MHz

Annex C EUT Photos

1. Test environment

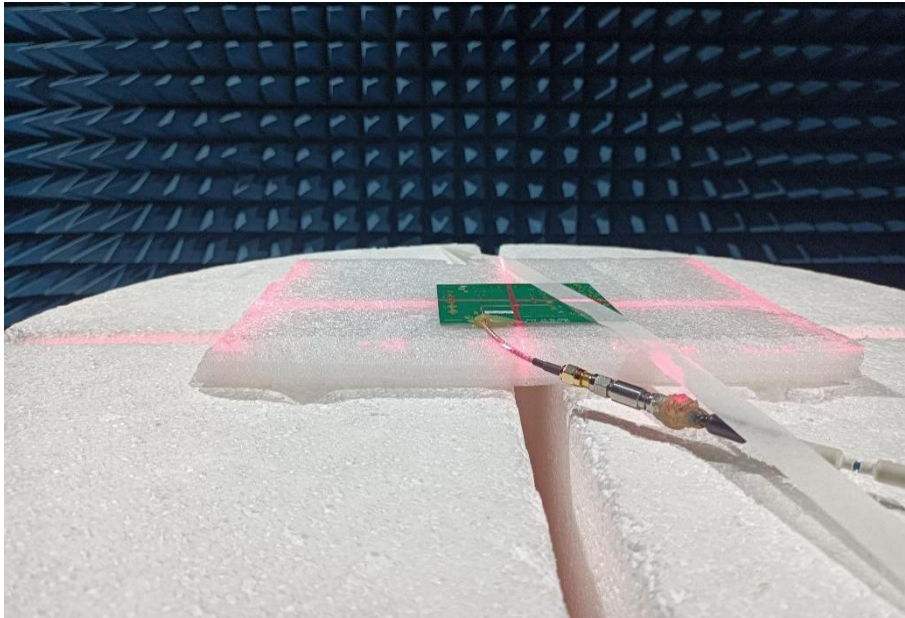

2. EUT

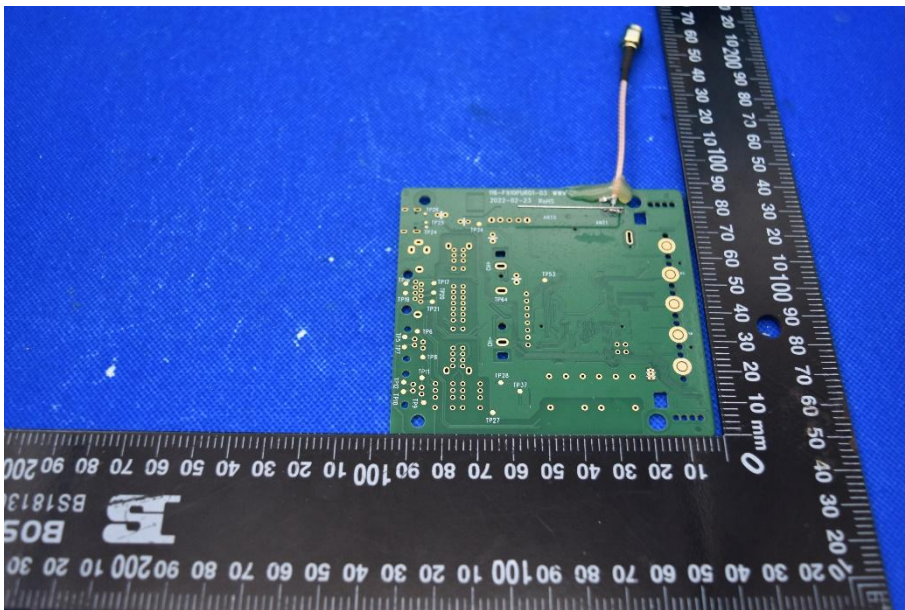

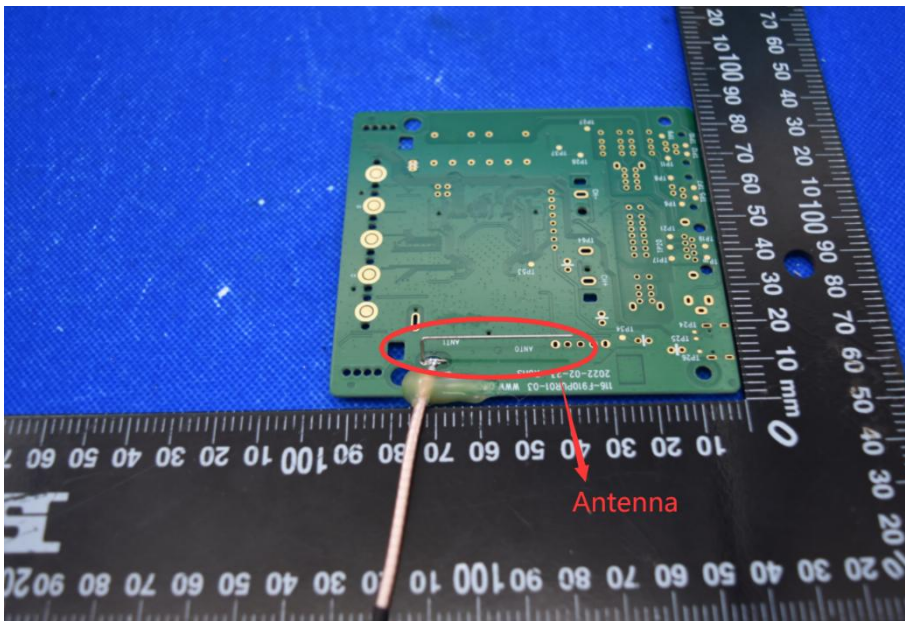
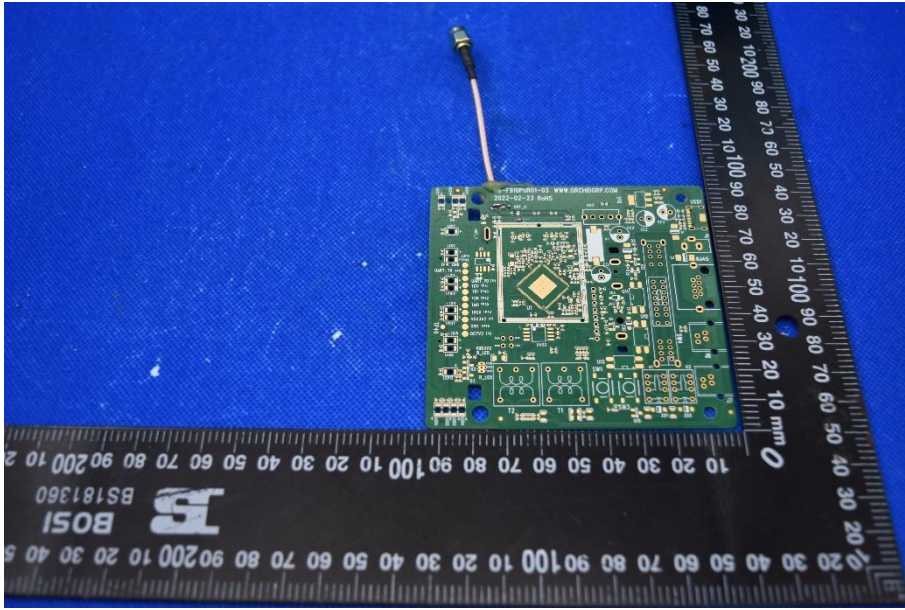



Annex D General Information

1.1 Identification of the Responsible Testing Laboratory

Laboratory Name:	Shenzhen Morlab Communications Technology Co., Ltd.
Laboratory Address:	FL1-3, Building A, FeiYang Science Park, No.8 LongChang Road, Block67, BaoAn District, ShenZhen, GuangDong Province, P. R. China
Telephone:	+86 755 36698555
Facsimile:	+86 755 36698525

1.2 Identification of the Responsible Testing Location

Name:	Shenzhen Morlab Communications Technology Co., Ltd.
Address:	FL1-3, Building A, FeiYang Science Park, No.8 LongChang Road, Block67, BaoAn District, ShenZhen, GuangDong Province, P. R. China

1.3 Test Equipments Utilized

No.	Equipement Name	Serial No.	Type	Manufa cturer	Cal.Date	Cal.Due Date
1	Network Analyzer	MY46110140	E5071C	Agilent	2022.07.04	2023.07.03
2	OTA Chamber	TJ2235-Q17 93	AMS-8923-1 50	ETS	2020.01.06	2023.01.05
3	Antenna Measurement System	1685	EMQuest EMQ-100 V 1.13 Build 21267	ETS	N/A	N/A

————— END OF REPORT —————