

IND256x

Weighing Terminal

Installation Manual | Guía de instalación |
Installationshandbuch | Guide d'installation |
Guida all'installazione | Guia de instalação



IND256x Weighing Terminal

METTLER TOLEDO Service

Essential Services for Dependable Performance of Your IND256x Weighing Terminal

Congratulations on choosing the quality and precision of METTLER TOLEDO. Proper use of your new equipment according to this Manual and regular calibration and maintenance by our factory-trained service team ensures dependable and accurate operation, protecting your investment. Contact us about a service agreement tailored to your needs and budget. Further information is available at www.mt.com/service.

There are several important ways to ensure you maximize the performance of your investment:

1. **Register your product:** We invite you to register your product at www.mt.com/productregistration so we can contact you about enhancements, updates and important notifications concerning your product.
2. **Contact METTLER TOLEDO for service:** The value of a measurement is proportional to its accuracy – an out of specification scale can diminish quality, reduce profits and increase liability. Timely service from METTLER TOLEDO will ensure accuracy and optimize uptime and equipment life.
 - a. **Installation, Configuration, Integration and Training:** Our service representatives are factory-trained, weighing equipment experts. We make certain that your weighing equipment is ready for production in a cost effective and timely fashion and that personnel are trained for success.
 - b. **Initial Calibration Documentation:** The installation environment and application requirements are unique for every industrial scale so performance must be tested and certified. Our calibration services and certificates document accuracy to ensure production quality and provide a quality system record of performance.
 - c. **Periodic Calibration Maintenance:** A Calibration Service Agreement provides on-going confidence in your weighing process and documentation of compliance with requirements. We offer a variety of service plans that are scheduled to meet your needs and designed to fit your budget.
 - d. **GWP® Verification:** A risk-based approach for managing weighing equipment allows for control and improvement of the entire measuring process, which ensures reproducible product quality and minimizes process costs. GWP (Good Weighing Practice), the science-based standard for efficient life-cycle management of weighing equipment, gives clear answers about how to specify, calibrate and ensure accuracy of weighing equipment, independent of make or brand.

© METTLER TOLEDO 2020

No part of this manual may be reproduced or transmitted in any form or by any means, electronic or mechanical, including photocopying and recording, for any purpose without the express written permission of METTLER TOLEDO.

U.S. Government Restricted Rights: This documentation is furnished with Restricted Rights.

Copyright 2020 METTLER TOLEDO. This documentation contains proprietary information of METTLER TOLEDO. It may not be copied in whole or in part without the express written consent of METTLER TOLEDO.

METTLER TOLEDO reserves the right to make refinements or changes to the product or manual without notice.

COPYRIGHT

METTLER TOLEDO® is a registered trademark of Mettler-Toledo, LLC. All other brand or product names are trademarks or registered trademarks of their respective companies.

METTLER TOLEDO RESERVES THE RIGHT TO MAKE REFINEMENTS OR CHANGES WITHOUT NOTICE.

FCC Notice

This device complies with Part 15 of the FCC Rules and the Radio Interference Requirements of the Canadian Department of Communications. Operation is subject to the following conditions: (1) this device may not cause harmful interference, and (2) this device must accept any interference received, including interference that may cause undesired operation.

This equipment has been tested and found to comply with the limits for a Class B digital device, pursuant to Part 15 of the FCC Rules. These limits are designed to provide reasonable protection against harmful interference in a residential installation. This equipment generates, uses and can radiate radio frequency energy and, if not installed and used in accordance with the instructions, may cause harmful interference to radio communications. However, there is no guarantee that interference will not occur in a particular installation. If this equipment does cause harmful interference to radio or television reception, which can be determined by turning the equipment off and on, the user is encouraged to try to correct the interference by one or more of the following measures:

- Reorient or relocate the receiving antenna.
- Increase the separation between the equipment and receiver.
- Connect the equipment into an outlet on a circuit different from that to which the receiver is connected.
- Consult the dealer or an experienced radio/TV technician for help.

The manufacturer is not responsible for any radio or TV interference caused by unauthorized modifications to this equipment. Such modifications could void the user's authority to operate the equipment.

■ Declaration of Conformity is available at
<http://glo.mt.com/global/en/home/search/compliance.html/compliance/>.

FCC RF Safety Statement

To satisfy FCC RF exposure requirements for mobile and base station transmission devices, a separation distance of 20 cm or more should be maintained between the antenna of this device and persons during operation. To ensure compliance, operation at closer than this distance is not recommended. The antenna(s) used for this transmitter must not be co-located or operating in conjunction with any other antenna or transmitter.

The device has been evaluated to meet general RF exposure requirement.

IC Notice

This device contains license-exempt transmitter(s)/receiver(s) that comply with Innovation, Science and Economic Development Canada's license-exempt RSS(s). Operation is subject to the following two conditions:

- (1) This device may not cause interference.
- (2) This device must accept any interference, including interference that may cause undesired operation of the device.

















L'émetteur/récepteur exempt de licence contenu dans la présent appareil est conforme aux CNR d'Innovation, Sciences et Développement économique Canada applicables aux appareils radio exempts de licence. L'exploitation est autorisée aux deux conditions suivantes :

- (1) L'appareil ne doit pas produire de brouillage ;
- (2) L'appareil doit accepter tout brouillage radioélectrique subi, même si le brouillage est susceptible d'en compromettre le fonctionnement.

















Avis : Pour répondre à la IC d'exposition pour les besoins de base et mobiles dispositifs de transmission de la station, sur une distance de séparation de 20 cm ou plus doit être maintenue entre l'antenne de cet appareil et les personnes en cours de fonctionnement. Pour assurer le respect, l'exploitation de plus près à cette distance n'est pas recommandée. L'antenne(s) utilisé pour cet émetteur ne doit pas être localisés ou fonctionner conjointement avec une autre antenne ou transmetteur.

Warnings and Cautions

- READ this manual BEFORE operating or servicing this equipment and FOLLOW these instructions carefully.
- SAVE this manual for future reference.

	<p style="text-align: center;"> WARNING</p> <p>DO NOT INSTALL OR PERFORM ANY SERVICE ON THIS EQUIPMENT BEFORE THE AREA IN WHICH THE IND256x IS LOCATED HAS BEEN SECURED AS NON-HAZARDOUS BY PERSONNEL AUTHORIZED TO DO SO BY THE RESPONSIBLE PERSON AT THE CUSTOMER'S SITE.</p>
	<p style="text-align: center;"> CAUTION</p> <p>CONFIRM COMPLIANCE WITH APPLICABLE NATIONAL AND LOCAL WIFI REGULATIONS BEFORE INSTALLING AND COMMISSIONING IND256x TERMINAL CONFIGURED WITH WIFI MODULE. METTLER TOLEDO ACCEPTS NO RESPONSIBILITY FOR TERMINAL INSTALLATION IN COUNTRIES WHERE WIFI REGULATIONS ARE NOT FULFILLED. PRODUCT WIFI APPROVALS CAN BE FOUND AT http://glo.mt.com/global/en/home/search/compliance.html/compliance/.</p>
	<p style="text-align: center;"> WARNING</p> <p>IF THE IND256x KEYBOARD, DISPLAY LENS OR ENCLOSURE IS DAMAGED, THE DEFECTIVE COMPONENT MUST BE REPLACED IMMEDIATELY. REMOVE POWER IMMEDIATELY AND DO NOT REAPPLY POWER UNTIL THE DISPLAY LENS, KEYBOARD OR ENCLOSURE HAS BEEN REPAIRED OR REPLACED BY QUALIFIED SERVICE PERSONNEL. FAILURE TO DO SO COULD RESULT IN BODILY HARM AND/OR PROPERTY DAMAGE.</p>
	<p style="text-align: center;"> WARNING</p> <p>AVOID ELECTROSTATIC CHARGING DURING OPERATION AND MAINTENANCE.</p>
	<p style="text-align: center;"> WARNING</p> <p>OPERATION IS ONLY PERMITTED WHEN OPERATIONAL AND PROCESS-RELATED ELECTROSTATIC CHARGES ARE NOT PRESENT.</p>
	<p style="text-align: center;"> WARNING</p> <p>USE THE WEIGHING TERMINAL ONLY WHEN ELECTROSTATIC PROCESSES LEADING TO PROPAGATION BRUSH DISCHARGE IS IMPOSSIBLE.</p>
	<p style="text-align: center;"> WARNING</p> <p>KEEP THE TERMINAL AWAY FROM PROCESSES THAT GENERATE HIGH CHARGING POTENTIAL SUCH AS ELECTROSTATIC COATING, RAPID TRANSFER OF NON-CONDUCTIVE MATERIALS, RAPID AIR JETS, AND HIGH PRESSURE AEROSOLS.</p>
	<p style="text-align: center;"> WARNING</p> <p>DO NOT USE DRY CLOTH TO CLEAN THE WEIGHING TERMINAL. ALWAYS USE A DAMP CLOTH TO CLEAN THE TERMINAL GENTLY.</p>

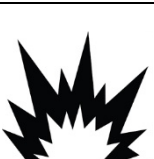
	! WARNING
	WEAR SUITABLE CLOTHING. AVOID NYLON, POLYESTER OR OTHER SYNTHETIC MATERIALS THAT GENERATE AND HOLD CHARGE. USE CONDUCTIVE FOOTWEAR AND FLOORING.
	! WARNING
	AVOID PLASTIC COVERS OVER THE TERMINAL.
	! WARNING
	ENSURE PROPER EQUIPOTENTIAL GROUNDING OF THE TERMINAL, MOUNTING ACCESSORIES, AND THE SCALE BASE.
	! WARNING
	TERMINAL MUST BE PROTECTED FROM UV LIGHT.
	! WARNING
	FOR THE DC VERSION OF THE IND256x TERMINAL, THERE IS NO GALVANIC SEPARATION BETWEEN NON-INTRINSICALLY SAFE SUPPLY CIRCUIT AND INTRINSICALLY SAFE OUTPUT CIRCUITS. THE NON-INTRINSICALLY SAFE CIRCUIT MUST BE SAFELY CONNECTED TO EARTH. AND POTENTIAL EQUALIZATION MUST EXIST ALONG INTRINSICALLY SAFE CIRCUITS. ALTERNATIVELY, THE NON-INTRINSICALLY SAFE SUPPLY CIRCUIT (SELV) MUST BE SAFELY SEPARATED FROM EARTH.
	! WARNING
	THE EXTERNAL CUSTOMER-PROVIDED DC POWER SUPPLY MUST HAVE A CATEGORY II MAXIMUM OVER-VOLTAGE, ACCORDING TO IEC 60664-1.
	! WARNING
	SUFFICIENT STRAIN RELIEF MUST BE ENSURED TO PREVENT TENSILE FORCES ON THE CABLE GLANDS.
	! WARNING
	THE CABLE GLANDS MUST BE PROTECTED AGAINST DAMAGE FROM IMPACT.
	! WARNING
	THE TERMINAL ASSEMBLED WITH WIFI ANTENNA SHALL BE INSTALLED IN A POSITION IN SUCH A WAY THAT THE RISK FOR MECHANICAL DAMAGE IS LOW. REPLACE THE WIFI ANTENNA IMMEDIATELY IF DAMAGED.
	! WARNING
	IND256x TERMINALS FACTORY-CONFIGURED WITH WIFI ARE APPROVED FOR USE IN ZONE 1 EQUIPMENT GROUP IIB CLASSIFIED AREAS. IND256x TERMINALS FACTORY-CONFIGURED WITH WIFI MUST NOT BE USED IN EQUIPMENT GROUP IIC CLASSIFIED AREA. USING THE IND256X TERMINAL FACTORY-CONFIGURED WITH WIFI IN A CLASSIFIED AREA FOR WHICH IT IS NOT APPROVED COULD RESULT IN BODILY HARM AND/OR PROPERTY DAMAGE.

	<p style="text-align: center;"> WARNING</p> <p>THE EXTERNAL CUSTOMER-PROVIDED DC POWER SUPPLY MUST HAVE A MAXIMUM OVER-VOLTAGE CATEGORY II ACCORDING TO IEC 60664-1.</p>
	<p style="text-align: center;"> WARNING</p> <p>DO NOT OPEN THE TERMINAL WHEN THE ATMOSPHERE IS EXPLOSIVE DUE TO DUST. TO PREVENT IGNITION OF HAZARDOUS ATMOSPHERES, DISCONNECT THE IND256x FROM ITS POWER SOURCE BEFORE OPENING THE ENCLOSURE. KEEP COVER TIGHTLY CLOSED WHILE THE CIRCUIT IS ENERGIZED. DO NOT OPEN WHEN AN EXPLOSIVE DUST ATMOSPHERE IS PRESENT.</p>
	<p style="text-align: center;"> WARNING</p> <p>ALL EQUIPMENT MUST BE INSTALLED PER MANUFACTURER'S DOCUMENT DRAWING NUMBER 30282892B AND APPLICABLE LOCAL CODES.</p>
	<p style="text-align: center;"> WARNING</p> <p>ONLY THE COMPONENTS SPECIFIED IN THE INSTALLATION MANUAL INCLUDED ON THE DOCUMENTATION CD-ROM 3051 2916 CAN BE USED IN THIS DEVICE. ALL EQUIPMENT MUST BE INSTALLED IN ACCORDANCE WITH THE INSTALLATION INSTRUCTIONS. INCORRECT OR SUBSTITUTE COMPONENTS AND/OR DEVIATION FROM THESE INSTRUCTIONS CAN IMPAIR THE INSTRINSIC SAFETY OF THE TERMINAL AND COULD RESULT IN BODILY INJURY AND/OR PROPERTY DAMAGE.</p>
	<p style="text-align: center;"> WARNING</p> <p>FOR CONTINUED PROTECTION AGAINST SHOCK HAZARD, CONNECT TO PROPERLY GROUNDED POWER SOURCE ONLY. DO NOT REMOVE THE GROUNDING CONNECTION.</p>
	<p style="text-align: center;"> WARNING</p> <p>WHEN THIS EQUIPMENT IS INCLUDED AS A COMPONENT PART OF A SYSTEM, THE RESULTING DESIGN MUST BE REVIEWED BY QUALIFIED PERSONNEL WHO ARE FAMILIAR WITH THE CONSTRUCTION AND OPERATION OF ALL COMPONENTS IN THE SYSTEM AND THE POTENTIAL HAZARDS INVOLVED. FAILURE TO OBSERVE THIS PRECAUTION COULD RESULT IN BODILY HARM AND/OR PROPERTY DAMAGE.</p>
	<p style="text-align: center;"> WARNING</p> <p>ONLY PERMIT QUALIFIED PERSONNEL TO SERVICE THE IND256x. EXERCISE CARE WHEN MAKING CHECKS, TESTS AND ADJUSTMENTS THAT MUST BE MADE WITH POWER ON. FAILING TO OBSERVE THESE PRECAUTIONS CAN RESULT IN BODILY HARM AND/OR PROPERTY DAMAGE.</p>
	<p style="text-align: center;"> WARNING</p> <p>BEFORE CONNECTING/DISCONNECTING ANY INTERNAL ELECTRONIC COMPONENTS OR INTERCONNECTING WIRING BETWEEN ELECTRONIC EQUIPMENT ALWAYS REMOVE POWER AND WAIT AT LEAST THIRTY (30) SECONDS BEFORE ANY CONNECTIONS OR DISCONNECTIONS ARE MADE. FAILURE TO OBSERVE THESE PRECAUTIONS COULD RESULT IN DAMAGE TO OR DESTRUCTION OF THE EQUIPMENT AND/OR BODILY HARM.</p>
	<p style="text-align: center;">NOTICE</p> <p>OBSERVE PRECAUTIONS FOR HANDLING ELECTROSTATIC SENSITIVE DEVICES.</p>

Disposal of Electrical and Electronic Equipment



In conformance with the European Directive 2002/96/EC on Waste Electrical and Electronic Equipment (WEEE) this device may not be disposed of in domestic waste. This also applies to countries outside the EU, per their specific requirements.

Please dispose of this product in accordance with local regulations at the collecting point specified for electrical and electronic equipment.

If you have any questions, please contact the responsible authority or the distributor from which you purchased this device.

Should this device be passed on to other parties (for private or professional use), the content of this regulation must also be related.

Thank you for your contribution to environmental protection.

Contents

1	Introduction	1-1
1.1.	IND256x Overview	1-1
1.2.	Product Specification	1-2
1.3.	Testing Standards	1-4
1.4.	Warnings and Precautions	1-6
1.5.	Inspection and Contents Checklist	1-6
1.6.	Configuration.....	1-7
1.7.	Equipotential Bonding (EB)	1-9
1.8.	Operating Environment	1-9
1.9.	Dimensions.....	1-10
1.10.	Main Board	1-12
1.11.	Communication Option Boards	1-12
2	Installation	2-1
2.1.	Opening the Enclosure.....	2-1
2.2.	Install Cables and Connectors	2-2
2.3.	Bonding and Grounding.....	2-6
2.4.	Equipotential Bonding (EB)	2-6
2.5.	Closing the Enclosure	2-7
2.6.	Analog Load Cell Connection	2-7
2.7.	Communication Boards Connection	2-8
2.8.	Sealing the Enclosure	2-12
2.9.	Interface Parameters.....	2-12

1 Introduction

1.1. IND256x Overview

The IND256x reflects the latest weighing technology from METTLER TOLEDO. The IND256x has passed third-party certification for weighing in hazardous areas, and can be directly used in Zone 1/Zone 21 locations.

A high-performance single-range or multi-range weighing terminal, the IND256x uses analog load cells to achieve reliable weighing at low cost, from grams to tons. It is easily integrated in an existing weighing system.

By connecting the appropriate safety barrier or isolated barrier, the IND256x can provide various intrinsically safe communication interfaces to communicate with PCs and printers in the safe area. These features permit IND256x to support a majority of weighing applications in most industrial fields, including:

- Pharmacy
- Powder processes
- Special chemicals
- Petrochemicals
- Agriculture
- Paints and inks
- Fine chemical engineering

1.1.1. IND256x Terminal Version

The IND256x is available with three different power supply choices:

- AC power input, using external alternating voltage (187-250 V 50/60 Hz)
- DC power input, using external direct voltage (DC 18-30 V)
- Intrinsically safe power input, using an external Ex NiMH battery pack (64060627)

Each of these versions has received ATEX and IECEx approvals for use in Zone 1 and Zone 21 classified areas.

1.1.2. IND256x Product Features

- Basic weighing in hazardous areas, including zero, tare and print functions
- Harsh environment desk, column- or wall-mounted enclosure
- Connects to a single analog weighing platform
- 240 x 96 pixel white backlit LCD, 25mm high digits
- Real-time clock (power-down save)

- Includes one intrinsically safe serial port (COM1) for asynchronous two-way communication and print output
- Support for the following internal option boards:
 - Intrinsically safe 4-20 mA analog output
 - WiFi communication module with antenna (only in IND256x terminals factory-configured with WiFi module)
 - Active current loop – for connection to an ACM200 communication module located in the safe area, or to connect second IND256x terminal configured with passive current loop option
 - Passive current loop (used as the second display to connect another terminal with an active current loop)
- Supports three customized ID inputs
- Target table supports 25 pre-set targets for Checkweighing
- Tare table supports 20 pre-set tare values
- Supports g, kg, t, ton, lb and oz
- Saves 60,000 transaction data items
- Supports accumulation and accumulative total
- Permits the customization of five different print templates
- Supports weight-free calibration (CalFREE™)

1.2. Product Specification

Table 1-1 shows the IND256x specifications.

Table 1-1: IND256x Specifications

Item	Specification
Enclosure	304 stainless steel, can be wall- or pole-mounted
Dimensions (h × w × d)	173 mm × 230 mm × 127 mm (6.8 in. × 9.1 in. × 5.0 in.)
Transport weight	3.5 kg (8 lb)
Protection grade	IP66
Storage environment	Storage temperature range: –20°C to 60° C (–4° to 140°F) Relative humidity: 10% to 95%, non-condensing
Service environment	Operating temperature range: –10°C to 40° C (14° to 104°F) Relative humidity: 10% to 95%, non-condensing

Item	Specification
Hazardous area	IND256x is approved for use in Zone 1/Zone 21 hazardous areas
Power supply	AC power (187-253V 50/60Hz) DC power (CD 18-30 V) External NiMH Ex battery pack (64060627)
Display	240 x 96 pixel white backlit LCD, 25mm high digits Display update rate: 10 Hz
Weight display	Maximum 100,000 divisions
Weighing platform type	Analog load cell
Sensor quantity	Maximum of four 350-ohm load cells (minimum 87 ohm), 2 mV/V or 3 mV/V
Weighing platform quantity	Supports one weighing platform
Refresh rate	>366 Hz
Sensor excitation voltage	4.5 VDC
Minimum sensitivity	0.6 μ V/e
Keyboard	26 keys; 1.5mm thick membrane keyboard
Communication mode	<p>Standard interface: The mainboard is provided with an intrinsically safe RS232 communication interface</p> <p>Interface options: Intrinsically safe 4-20 mA analog output module, with 16-bit D/A conversion and 25 Hz update rate to PLC or WiFi communication module (only in IND256x terminals factory-configured with WiFi module); or Intrinsically safe active current loop or Intrinsically safe passive current loop</p> <p>Communication Protocols: Serial port input: ASCII commands - CTPZ (Clear, Tare, Print, Zero), SICS commands (supports SICS level 0 and level 1) Serial port output: Toledo continuous output, command print output (5 configurable templates), SICS command and report print</p>
Metrological Approval	Europe: OIML R76; Class III, 6000e; TC10878 Global: OIML R76; Class III, 6000e; R76-2006-A-NL1-18.27
Hazardous Area Approval, factory-configured WiFi version	<p>Hazardous approval with non-intrinsically safe power supply (AC version and DC version): II 2G Ex eb ib [ib] mb IIB T4 Gb II 2D Ex tb [ib] IIIC T60°C Db</p> <p>with intrinsically safe battery: II 2G Ex ib IIB T4 Gb II 2D Ex tb [ib] IIIC T60°C Db</p>

Item	Specification
Hazardous Area Approval, version without WiFi	with non-intrinsically safe power supply (AC version and DC version): II 2G Ex eb ib [ib] mb IIC T4 Gb II 2D Ex tb [ib] IIIC T60°C Db with intrinsically safe battery: II 2G Ex ib IIC T4 Gb II 2D Ex tb [ib] IIIC T60°C Db

Table 1-2: WiFi Module Specification (only for IND256x terminals factory-configured with WiFi module)

Item	Specification
Standard	802.11 b/g/n
Transmitting Power	14dBm (average)
RF Frequency Range	2.4GHz – 2.497GHz
Encryption	WEP, WPA
WEP	64 Bit, 128 Bit
WPA	WPA-TKIP, WPA2-AES
Protocol	TCP/IP
Work Mode	Server, Client
Transmitting distance	Max 50 meters in the open air
Approval	China: SRRC

1.3. Testing Standards

The IND256x terminal has been tested according to the following standards.

EN 60079-0:2012 + A11:2013	General requirements
EN 60079-7:2015	Increased safety "e"
EN 60079-11:2012	Intrinsic safety "i"
EN 60079-18:2015	Encapsulation "m"
EN 60079-31:2014	Protection by Enclosure "t"
IEC 60079-0:2017, Ed. 7.0	General requirements
IEC 60079-7:2017, Ed. 5.1	Increased safety "e"
IEC 60079-11:2011, Ed. 6.0	Intrinsic safety "i"
IEC 60079-18:2017, Ed. 4.1	Encapsulation "m"
IEC 60079-31:2013, Ed .2.0	Protection by Enclosure "t"
FM3600 (2011)	Electrical Equipment for Use In Hazardous (Classified) Locations - General Requirements

FM3610 (2010)	Intrinsically Safe Apparatus and Associated Apparatus for Use in Class I, II & III, Division 1, Hazardous (Classified) Locations
FM3810 (2005)	Electrical Equipment for Measurement, Control and Laboratory Use
ANSI/IEC 60529	Degrees of Protection Provided by Enclosure(IP Code)
CSA C22.2 No. 157-1992 / 2006	Intrinsically safe and non-Incentive equipment for use in hazardous locations
CSA C22.2 No. 142-1990 / 2004	Process control equipment
CSA C22.2 No. 61010.1-2004	Safety requirements for electrical equipment for measurement, control, and laboratory use – Part 1: General requirements
CAN/CSA 22.2 No. 60529-2005	Degrees of Protection Provided by Enclosure (IP Code)

1.3.1. **Special Conditions for Safe Use**

1. The apparatus must be protected from UV-light
2. Electrostatic charging during operation and maintenance has to be excluded. The terminal shall only be installed in areas where operational and process related electrostatic charges are not present.
3. For versions with non-intrinsically safe DC-supply (type key ends with "44" or "46"): There is no galvanic separation between non-intrinsically safe supply circuit and intrinsically safe output circuits:

The non-intrinsically safe supply circuit has to be safely connected to earth. In this case, the intrinsically safe circuits are earthed as well. Along the intrinsically safe circuits, potential equalization must exist.







or

The non-intrinsically safe circuit has to be safely separated from earth (e.g. SELV-circuit).
4. For DC version terminal, the supply circuit shall have at a maximum overvoltage category II according to IEC 60664-1.
5. The cable glands Series HSK-M-Ex... and V-Ms-Ex... according to KEMA 99 ATEX 6971X resp. IECEx BVS 07.0014X are tested with a reduced tensile force (25%) in accordance with clause A.3.1 if IEC 60079-0 and may only be used for fixed installation of group II apparatus. The user shall ensure adequate clamping of the cable.
6. The WiFi antenna is tested for low risk of mechanical danger (impact height 0.4m with 1kg mass) and shall be protected against high impact energy levels.

1.4. Warnings and Precautions

Please read these instructions carefully before putting the new terminal into operation.

Although the IND256x is ruggedly constructed, it is nevertheless a precision instrument. Use care in handling and installing the terminal.

	WARNING
	DO NOT INSTALL OR PERFORM ANY SERVICE ON THIS EQUIPMENT BEFORE THE AREA HAS BEEN SECURED AS NON-HAZARDOUS BY PERSONNEL AUTHORIZED TO DO SO BY THE RESPONSIBLE PERSON AT THE CUSTOMER'S SITE.
	WARNING
	ONLY THE COMPONENTS SPECIFIED IN THIS MANUAL CAN BE USED IN THIS TERMINAL. ALL EQUIPMENT MUST BE INSTALLED IN ACCORDANCE WITH THE INSTALLATION INSTRUCTIONS DETAILED IN THIS MANUAL. INCORRECT OR SUBSTITUTE COMPONENTS AND/OR DEVIATION FROM THESE INSTRUCTIONS CAN IMPAIR THE INTRINSIC SAFETY OF THE TERMINAL AND COULD RESULT IN BODILY INJURY AND/OR PROPERTY DAMAGE.
	WARNING
	DO NOT OPEN WHEN ENERGIZED.
	WARNING
	POTENTIAL ELECTROSTATIC CHARGING HAZARD- SEE INSTRUCTIONS.
	WARNING
	DO NOT OPEN WHEN AN EXPLOSIVE ATMOSPHERE IS PRESENT.
	WARNING
	THE TERMINAL ASSEMBLED WITH WIFI ANTENNA SHALL BE INSTALLED IN A POSITION IN SUCH A WAY THAT THE RISK FOR MECHANICAL DAMAGE IS LOW. REPLACE THE WIFI ANTENNA IMMEDIATELY IF DAMAGED!

1.5. Inspection and Contents Checklist

On receipt of IND256x, check that the packaging is intact. If the box is damaged, check whether IND256x is damaged and, if necessary, lodge a freight claim with the carrier. If the packaging is not damaged, unpack the IND256x, paying attention to its original packaging, and check that nothing is damaged.

-  To ensure safe transport, it is best to use the original packaging and the correct packaging method.

The packaging box contains:

- IND256x weighing terminal
- Documentation CD (including manual and certificate of inspection)
- Bag of accessories for use during installation

1.6. Configuration

1.6.1. System Configuration

Figure 1-1 shows the configuration options for the terminal.

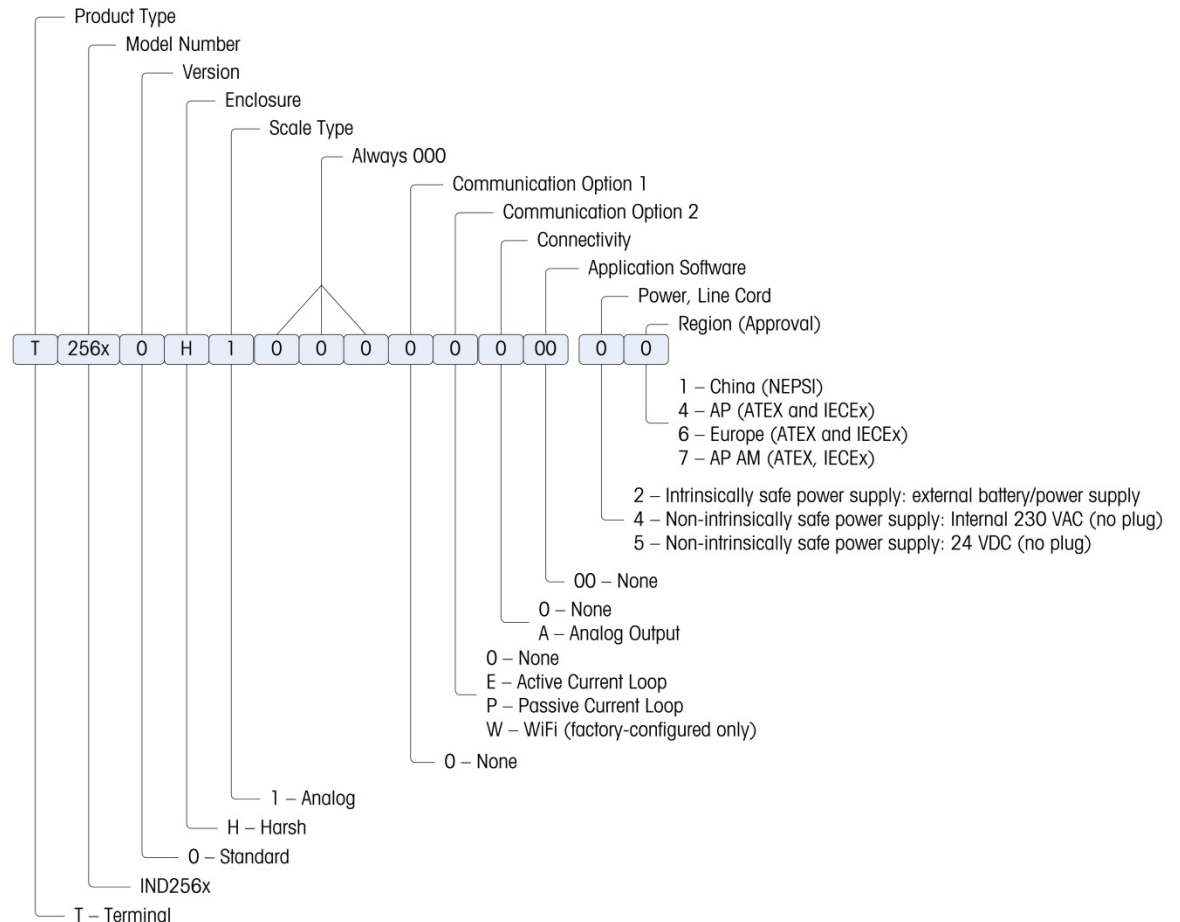
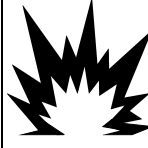



Figure 1-1: IND256x Configuration Chart

	 WARNING
	<p>IND256x TERMINALS FACTORY-CONFIGURED WITH WIFI ARE APPROVED FOR USE IN ZONE 1 EQUIPMENT GROUP IIB CLASSIFIED AREAS. IND256x TERMINALS FACTORY-CONFIGURED WITH WIFI MUST NOT BE USED IN EQUIPMENT GROUP IIC CLASSIFIED AREA. USING THE IND256x TERMINAL FACTORY-CONFIGURED WITH WIFI IN A CLASSIFIED AREA FOR WHICH IT IS NOT APPROVED COULD RESULT IN BODILY HARM AND/OR PROPERTY DAMAGE.</p>

NOTICE

WiFi CAPABILITY IS ONLY AVAILABLE IN IND256x TERMINALS SO CONFIGURED AT THE FACTORY.

1.6.2. Product Date Code

The manufacturing date or the date code for the terminal can be found on the serial data plate (on the top of the enclosure).

The serial number will begin with a letter and a number (for example B212000371). The letter represents the first three digits of the year per the date code chart in Table 1-3 (the letter “B” in our example represents “201x”) and the number is the unit’s digit of the year (the number “2” in our example). So, “B4” decodes to the year 2014.

Table 1-3: Current and Later Date Code Formats

Date Code	Year	Date Code	Year
A	200x	F	205x
B	201x	G	206x
C	202x	H	207x
D	203x	J	208x
E	204x	K	209x

1.6.3. Connections

The following figure shows the connection locations on the back of the harsh enclosure.

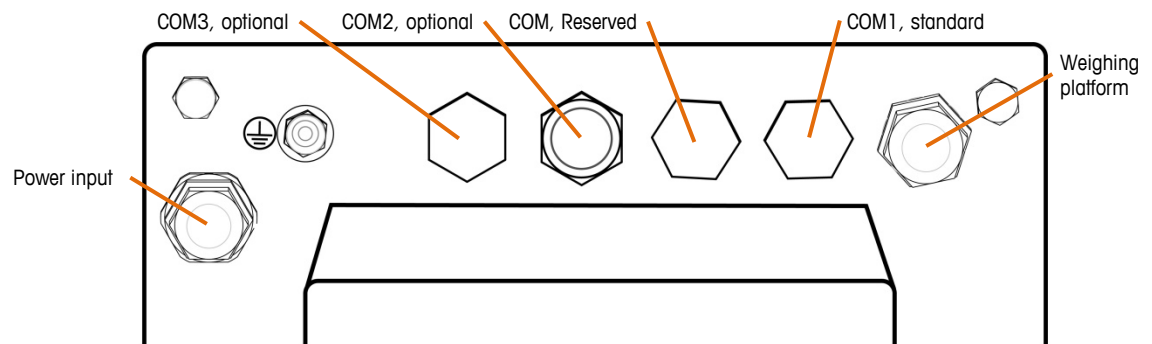
**Figure 1-2: IND256x Connection Port Locations**

Power input	AC power supply 220V (187-250V 50/60Hz) input (ATEX & IECEx version) <i>or</i> DC power supply 24V(18V-30V) input (ATEX & IECEx version) <i>or</i> external Ex battery
COM1 (standard)	intrinsically safe RS232
COM2 (optional)	intrinsically safe analog 4-20mA output <i>or</i> Wi-Fi communication module (factory-configured only)

COM3 (optional)	intrinsically safe active current loop <i>or</i> intrinsically safe passive current loop
COM Reserved	Not used

1.6.4. Warnings

1.6.4.1. CENELEC

Connection of EB per Country-Specific Regulations: It must be ensured that the housings of all devices are connected to the same potential via the EB terminals. No circulating current may flow via the shielding of the intrinsically safe cables.

1.6.4.2. cFMus

Connection of EB per ANSI/NFPA 70, Article 504, and ANSI/IA RP 12.06.01 or Canadian Electric Code C22.2: It must be ensured that the housings of all devices are connected to the same potential via the EB terminals. No circulating current may flow via the shielding of the intrinsically safe cables.

1.7. Equipotential Bonding (EB)

Equipotential bonding must be installed by an electrician authorized by the owner. METTLER TOLEDO Service performs only a monitoring and consulting function for this procedure.

Connect equipotential bonding of all devices (power supply unit, weighing terminal, interface converter and weighing platform) in accordance with the terminal diagram and all country-specific regulations and standards. In the process, it must ensure that:

- All device housings are connected to the same potential via the EB terminals.
- No circulating current flows via the cable shielding for intrinsically safe circuits.
- The neutral point for equipotential bonding is as close to the weighing system as possible.

1.8. Operating Environment

When selecting a location:

- Choose a stable, vibration-free surface to mount the terminal
- Ensure there are no excessive fluctuations in temperature and there is **no direct exposure to sunlight**
- Avoid drafts on the weighing platform (for example, from open windows or air conditioning)
- Calibrate the terminal after any major change of geographical location

1.8.1.1. Temperature and Humidity

The IND256x can be stored and operated at temperatures and relative humidity conditions as listed in Table 1-1.

1.8.1.2. Environmental Protection

The IND256x terminal has environmental protection as listed in Table 1-1.

1.9. Dimensions

Figure 1-3 and Figure 1-4 show the terminal's dimensions. Units are inches and [mm].

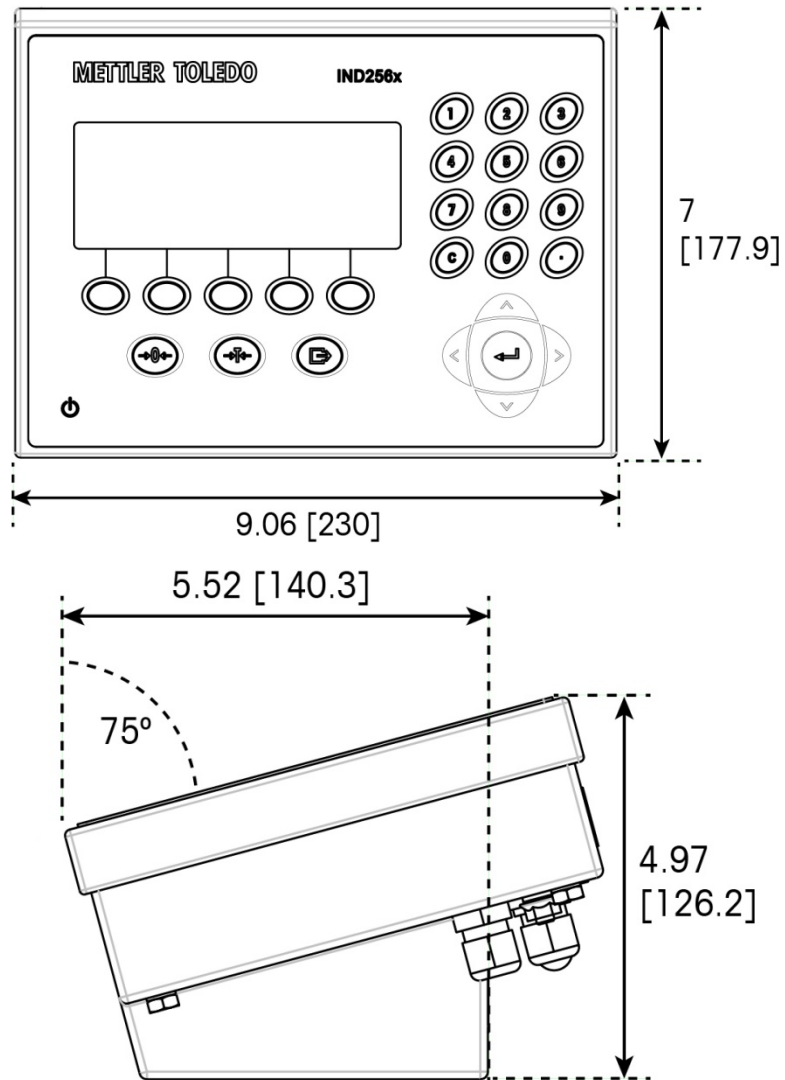

Figure 1-3: IND256x Dimensions, Desktop Installation

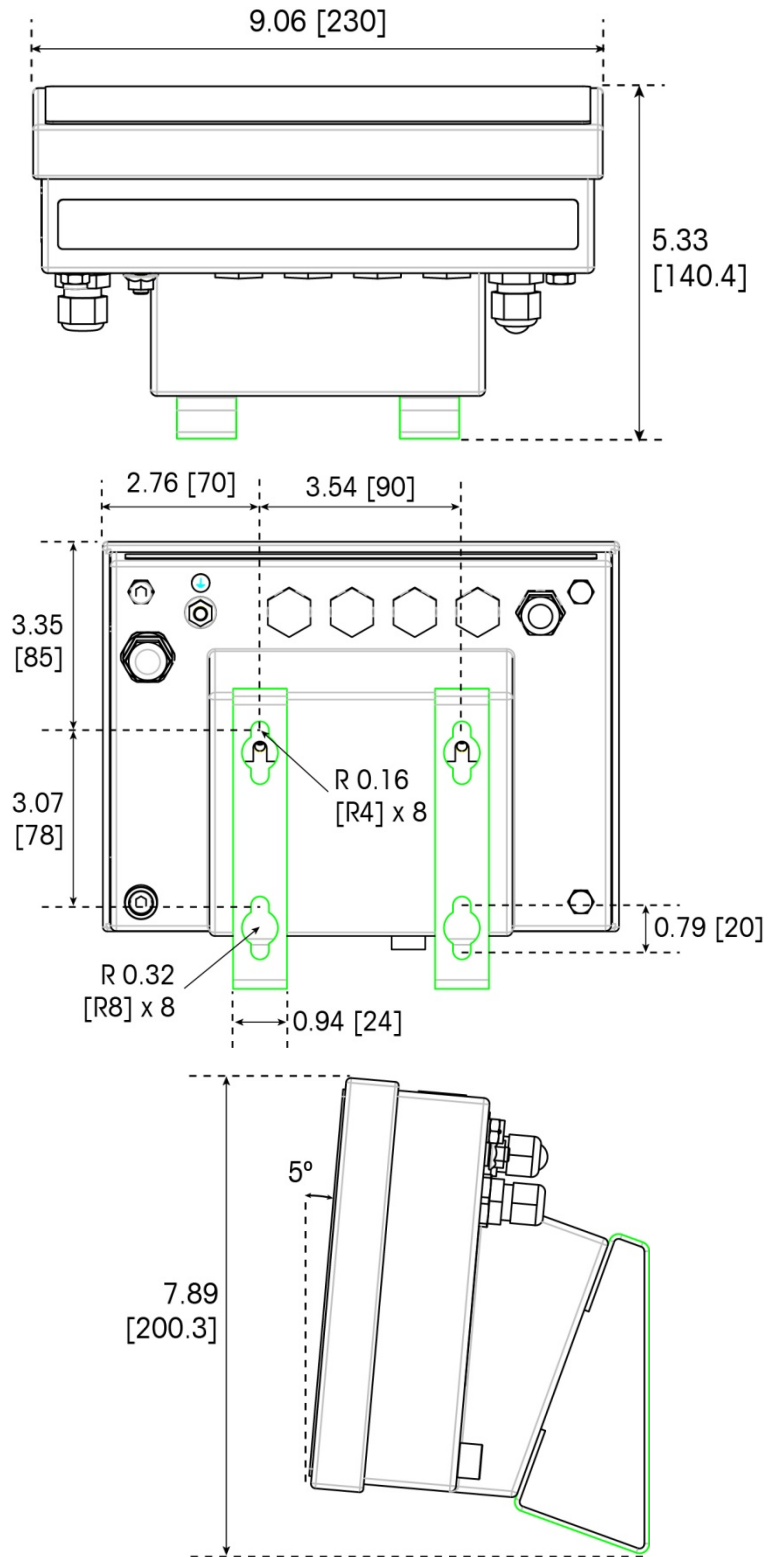

Figure 1-4: IND256x Dimensions, with Fixed Wall-Mount Bracket

1.10. Main Board

The IND256x main board has the following main connections, indicated in Figure 1-5:

1. Analog load cell weighing interface
2. Intrinsically safe power input interface, connecting the power module
3. Flat ribbon harness interface, used to connect the display
4. Intrinsically safe RS232 interface (COM1)
5. Two communication option board interfaces (COM2 and COM3)

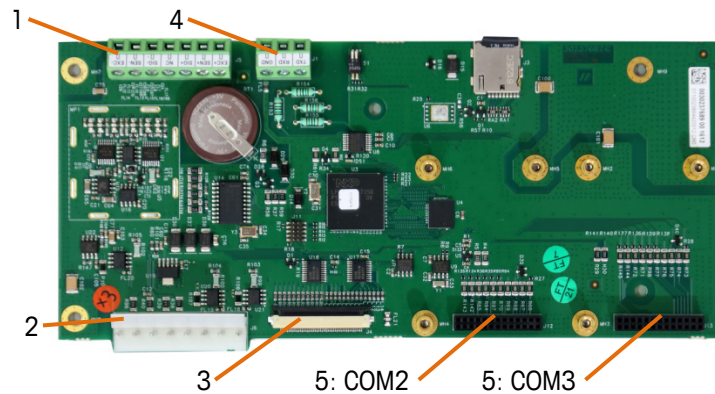

Figure 1-5: IND256x Main Board







1.11. Communication Option Boards

The IND256x can be configured with a maximum of two of the three communication option boards installed inside its enclosure. The options are:

- WiFi communication module (available only in IND256x terminals factory-configured with WiFi)
- Intrinsically safe 3-20 mA analog output
- Active current loop for connection to communication module ACM200 located in the safe area, or to connect second IND256x terminal configured with passive current loop option
- Passive current loop (used as the second display to connect another IND256x with active current loop)

2 Installation

2.1. Opening the Enclosure

	<p> WARNING</p> <p>DO NOT INSTALL OR PERFORM ANY SERVICE ON THIS EQUIPMENT BEFORE THE AREA HAS BEEN SECURED AS NON-HAZARDOUS BY PERSONNEL AUTHORIZED TO DO SO BY THE RESPONSIBLE PERSON AT THE CUSTOMER'S SITE.</p>
	<p> CAUTION</p> <p>CONFIRM COMPLIANCE WITH APPLICABLE NATIONAL AND LOCAL WIFI REGULATIONS BEFORE INSTALLING AND COMMISSIONING IND256x TERMINAL CONFIGURED WITH WIFI MODULE. METTLER TOLEDO ACCEPTS NO RESPONSIBILITY FOR TERMINAL INSTALLATION IN COUNTRIES WHERE WIFI REGULATIONS ARE NOT FULFILLED. PRODUCT WIFI APPROVALS CAN BE FOUND AT http://glo.mt.com/global/en/home/search/compliance.html/compliance/.</p>
	<p> WARNING</p> <p>TO PREVENT IGNITION OF HAZARDOUS GAS, BE SURE TO CUT OFF THE POWER BEFORE OPENING IND256X ENCLOSURE. AFTER IND256X IS POWERED ON, KEEP THE ENCLOSURE STRICTLY SEALED. DO NOT OPEN THE CASE IN THE PRESENCE OF EXPLOSIVE DUST OR GAS.</p>

Open IND256x terminal according to the steps in the following sections.

The front cover of the IND256x terminal is attached by 4 screws. For hardware configuration inside the instrument, open it as shown below:

1. Place the terminal face-down on a flat surface, taking care not to damage the fascia.
2. Unscrew the four captive screws indicated in Figure 2-1.



Figure 2-1: Enclosure screws

- Lift the rear cover and flip it to expose its interior. Note the two straps that secure the front panel to the enclosure.

2.2. Install Cables and Connectors

The cables and connectors of IND256x terminal are as follows:

- Harsh Enclosure Cable Glands
- Mainboard Wiring Connections
- Power Connection

	WARNING
	ONLY PROFESSIONAL SERVICE PERSONNEL MAY OPERATE THIS INSTRUMENT. BE CAREFUL DURING INSPECTION, TEST AND ADJUSTMENT. INCORRECT OPERATION MAY RESULT IN INJURY.

The IND256x terminal is suitable for severe wash-down and dust environments. However, it is necessary to access the interior of the terminal enclosure when installing cables and/or connectors. Each cable entering the enclosure is allocated a specific position.

2.2.1. Harsh Enclosure Cable Glands

To ensure water resistance and dust sealing:

- Pass the appropriately sized cable through the correct gland before connecting the wires. Depending upon the gland size, cables of a specific diameter must be used. The required cable sizes are shown in Table 2-1.

Table 2-1: Cable Diameters for Glands

Gland	Cable diameter
Analog load cell	6–10 mm (0.24–0.39 in.)
COM1 (IS-RS232)	6–10 mm (0.24–0.39 in.)
Current loop (active & passive)	6–10 mm (0.24–0.39 in.)
AC/DC Power cable	6–10 mm (0.24–0.39 in.)
4-20 mA analog output	6–10 mm (0.24–0.39 in.)
External battery	4-8 mm (0.16–0.3 in)

Important Notes:

- Use only ATEX-certified glands and blanks with the IND256x terminal.
- The cable glands must be protected against damage from impact.
- Sufficient strain-relief must be ensured to prevent tensile forces on the cable glands.

2. When making cable terminations inside the harsh enclosure, ensure that the cable length from the terminal strip/connector to the terminal housing is sufficient so that no strain is placed on the connector assembly when the housing is in the fully open position.
3. Cables that include shields should have the shield terminated at the gland as shown in Figure 2-2. Spread the shield wires out and make sure enough shield wire is present to make good contact with the metal part of the gland.

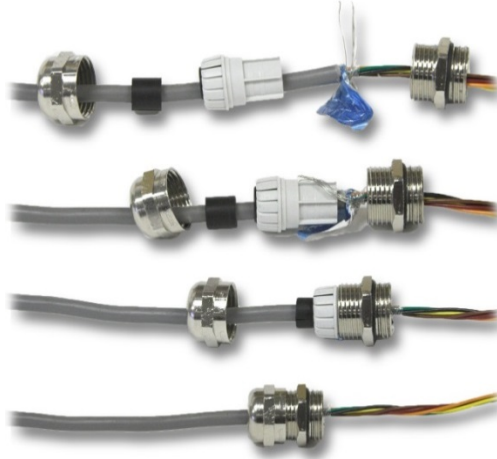



Figure 2-2: Shield Termination at Gland

2.2.2. Power Connection

	 WARNING
	THE MAINS CONNECTION OF THE POWER SUPPLY UNIT MUST BE MADE BY A PROFESSIONAL ELECTRICIAN AUTHORIZED BY THE OWNER AND IN ACCORDANCE WITH THE RESPECTIVE TERMINAL DIAGRAM, THE ACCOMPANYING INSTALLATION INSTRUCTIONS AS WELL AS THE COUNTRY-SPECIFIC REGULATIONS.

Where IECEx & ATEX are accepted, the IND256x can be powered by either:

- An internal power supply connected to an external AC230V or DC 24V power input, or
- An external NiMH battery (P/N 64060625).

The IND256x can use any of three encapsulated power boards, each supporting a different power input. Power is connected via an increased safety connector at the right corner inside the enclosure (Figure 2-3). The connector is protected by a plastic cover.

For the internal AC or DC power input version, the terminal is supplied with a 5 meter power cable, without plug. Terminals with an intrinsically safe power supply are supplied without a power cable.

2.2.2.1. Internal AC Power Input (IECEX & ATEX Approved Terminals Only)

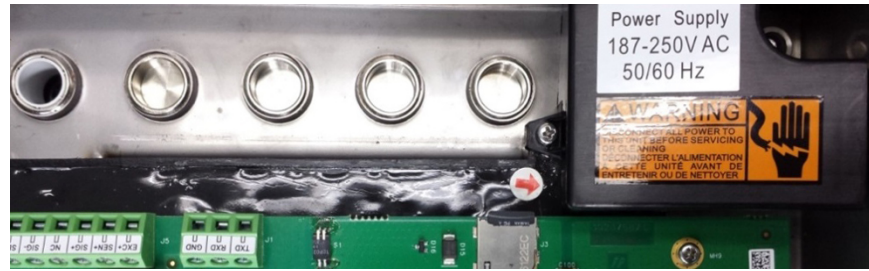

Figure 2-3: AC Power Input Connector with Cover

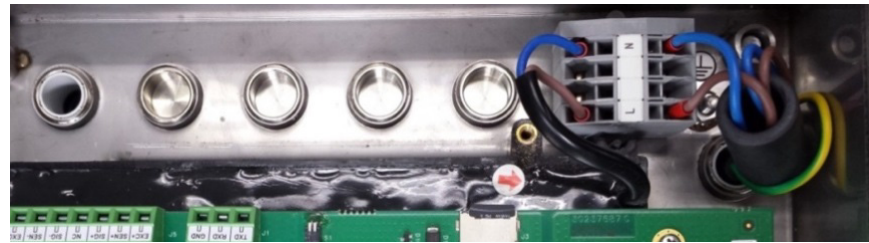

Figure 2-4: AC Power Input Connector, Cover Removed

Table 2-2: AC Power Input Cable Color Code

Pin	Pin color
L	Brown
N	Blue

2.2.2.2. Internal DC power input (IECEX & ATEX Approved Terminals Only)







	 WARNING
	THE DC POWER SUPPLY MUST BE CONNECTED TO AN 18-30V DC INPUT. DO NOT CONNECT TO AC POWER
	 WARNING
	FOR IND256X DC VERSION TERMINALS, THERE IS NO GALVANIC SEPARATION BETWEEN THE NON-INTRINSICALLY SAFE SUPPLY CIRCUIT AND THE INTRINSICALLY SAFE OUTPUT CIRCUITS. THE NON-INTRINSICALLY SAFE CIRCUIT MUST BE SAFELY CONNECTED TO EARTH. AND POTENTIAL EQUALIZATION MUST EXIST ALONG INTRINSICALLY SAFE CIRCUITS. ALTERNATIVELY, THE NON-INTRINSICALLY SAFE SUPPLY CIRCUIT (SELV) MUST BE SAFELY SEPARATED FROM EARTH.
	 WARNING
	THE EXTERNAL CUSTOMER-PROVIDED DC POWER SUPPLY MUST HAVE A MAXIMUM OVER-VOLTAGE CATEGORY II ACCORDING TO IEC 60664-1.



Figure 2-5: DC Power input Connector with Cover

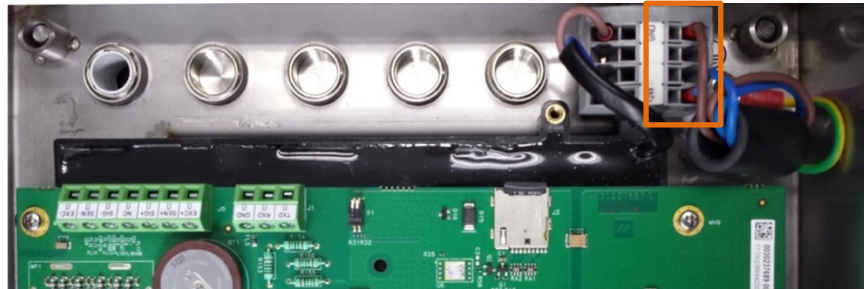

Figure 2-6: DC Power input Connector without Cover

Table 2-3: DC Power Input Cable Color Code

Pin	Pin color
GND	Brown
+24V	Blue

A.2.2.3

External NiMH Battery or Power Supply Input

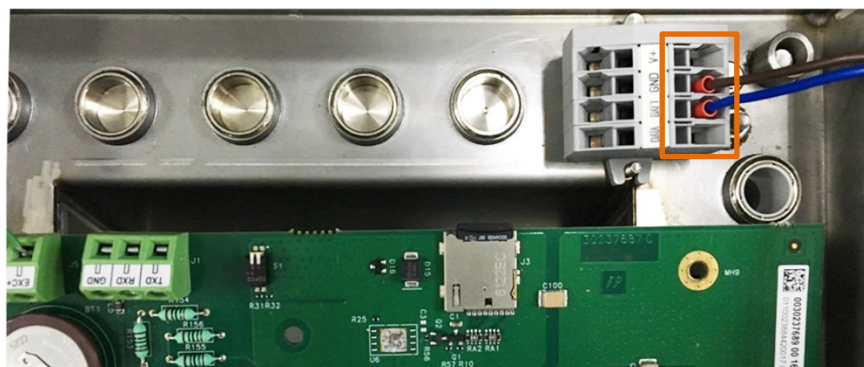

Figure 2-7: NiMH battery input connector internal view

Table 2-4: NiMH Battery Input Cable Color Code

Pin	Pin color
DATA	Empty
BATT	Blue
GND	Brown

Pin	Pin color
V+	Empty

2.3. Bonding and Grounding

All grounding and equal potential bonding connections must be made according to local regulations applicable in the country of installation. Refer to local codes and the control drawings for more specific information regarding grounding.

It is typical that local regulations will require that all connected pieces of equipment in the system be bonded together and grounded to a single point. A special external ground screw designed for equal potential bonding is provided on the IND256x terminal (Figure 2-8).



Figure 2-8: IND256x Terminal Grounding Screw

2.4. Equipotential Bonding (EB)

Equipotential bonding must be installed by an electrician authorized by the owner. METTLER TOLEDO Service performs only a monitoring and consulting function for this procedure.

Connect equipotential bonding of all devices (power supply unit, weighing terminal, interface converter and weighing platform) in accordance with the terminal diagram and all country-specific regulations and standards. In the process, it must ensure that:

- All device housings are connected to the same potential via the EB terminals.
- No circulating current flows via the cable shielding for intrinsically safe circuits.
- The neutral point for equipotential bonding is as close to the weighing system as possible.

2.4.1. Warnings

2.4.1.1. CENELEC

2.4.1.1.1. Connection of EB per Country-Specific Regulations

It must be ensured that the housings of all devices are connected to the same potential via the EB terminals. No circulating current may flow via the shielding of the intrinsically safe cables.

2.4.1.2. cFMus

2.4.1.2.1. Connection of EB per ANSI/NFPA 70, Article 504, and ANSI/IA RP 12.06.01 or Canadian Electric Code C22.2

It must be ensured that the housings of all devices are connected to the same potential via the EB terminals. No circulating current may flow via the shielding of the intrinsically safe cables.

2.5. Closing the Enclosure

To ensure that the front cover is correctly installed:

- Place the front cover on a flat surface
- Ensure that the seal ring is accurately located
- Install the rear cover and ensure it is accurately positioned
- Install the screws in their original positions
- Tighten each screw to 3.0 Nm

2.6. Analog Load Cell Connection

Analog cells are connected to the mainboard at the connector show in Chapter 1, Introduction.

The IND256x terminal is designed to power up to four 350-ohm load cells (or a minimum resistance of approximately 87 ohms). To confirm that the load cell load for the installation is within limits, the total scale resistance (TSR) must be calculated.

To calculate TSR:

$$\text{TSR} = \frac{\text{Load Cell Input Resistance } (\Omega\text{ms})}{\text{Number of cells}}$$

Ensure that the TSR of the load cell network to be connected to the IND256x has a resistance greater than 87 ohms before connecting the load cells. If the resistance is less than 87 ohms, the IND256x will not operate properly.

In addition, the maximum cable distance must be reviewed. Table 2-5 provides recommended maximum cable lengths based on cable gauge and correct operation of the terminal. Note that the entity values for the load cell cable must be considered as a safety factor in the installation.

Table 2-5: Maximum Recommended Cable Lengths

TSR (Ohms)	24 Gauge (meters/feet)	20 Gauge (meters/feet)	16 Gauge (meters/feet)
One to four-350 Ω cells	60/200	182/600	304/1000

Figure 2-9 shows the wiring for analog load cells. When a four-conductor cell is used, +Exc must be jumpered to +Sen and -Exc jumpered to -Sen.

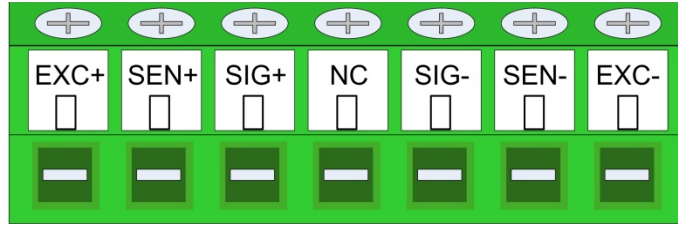

NOTES

1. WIRE SIZE: 18 AWG (0.823 mm²) MAX., 24 AWG (0.205 mm²) MIN.
2. CHASSIS GROUND: METAL GLAND

Figure 2-9: Load Cell Termination

2.7. Communication Boards Connection

2.7.1. Serial Port (COM1)

The COM1 port includes connections for an intrinsically safe serial device. Figure 2-10 indicates the COM1 port connector. The cable length of this connection is limited to 10m (33 ft.).

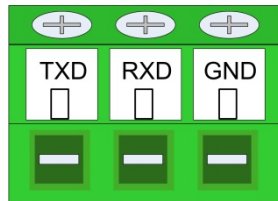

IND256x	Signal
J1 - 1	TxD—send data
J1 - 2	RxD—receive data
J1 - 3	GND—logic ground

Figure 2-10: COM1 Port Signals

An example of connecting to an RS-232 device in the safe area through a Zener diode barrier is shown in Figure 2-11. Refer to the entity approval values of COM1 when selecting a barrier. Note that seals and other protective devices will also be required to meet hazardous area wiring codes.

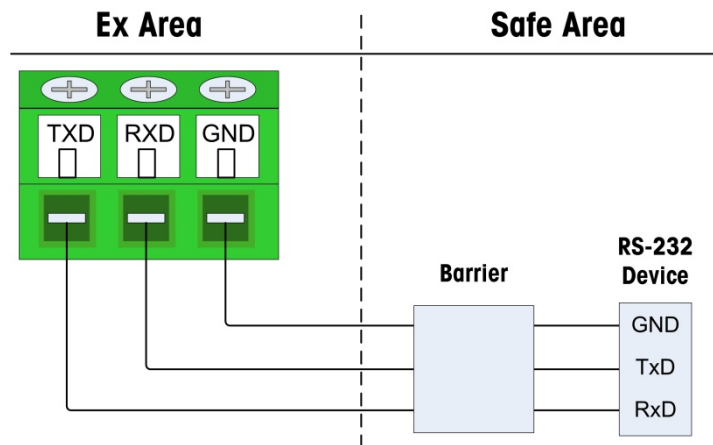

Figure 2-11: Sample RS-232 Connection

A barrier that has been tested for correct operation with the IND256x, and can be connected directly to COM1, is:

- MTL7761Pac (IECEx and ATEX approvals)

2.7.2. Active Current Loop

The active current loop option board can only be installed in the COM3 socket of the mainboard. When IND256x is connected to ACM200, it is necessary to connect the ACM200 using the active current loop to achieve communication in the safety area.

Table 2-6: Active Current Loop Connections to ACM200

IND256x COM3 (J2)	ACM200 COM (J3)
1	4
2	3
3	2
4	1

Customer-specific cables for intrinsically safe circuits must be customized as follows:

	IND256x – ACM200
Cable	2 x 2 x 0.5 mm ²
Dimension A (IND256x)	110 mm (2.4")
Dimension B (ACM200)	70 mm (2.8")
Max. length	300 m (1000 ft)

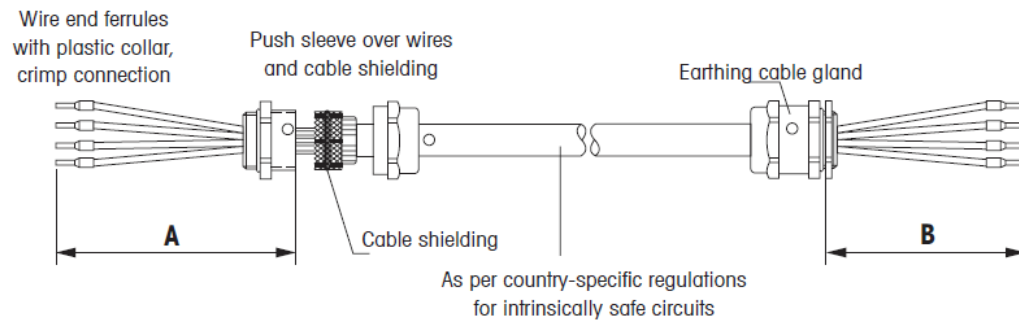

4. Cut the cable to length and strip the cable ends according to dimension A/B.
5. Shorten cable shielding on both sides to 10 mm (0.4").
6. Strip wire ends.
7. Crimp wire end ferrules onto wire ends with a crimping tool.
8. Push second rear section of the earthing cable gland onto the cable.
9. Apply the cable shielding only to the IND256x end by pushing the sleeve over the wires and the cable shielding and folding it over the cable shielding.
10. Push on front section of cable gland and screw it onto the rear section.

2.7.3. Passive Current Loop

If IND256x terminal is connected to another IND256x weighing system as remote display, the passive current loop interface must be connected to the active current loop of another IND256x terminal. The passive current loop can only be installed in the COM3 socket of the mainboard.

Table 2-7: Passive Current Loop Connection Between Terminals

IND256x COM3 (passive current loop J4) (Remote display)		IND256x COM3 (active current loop J2) (Instrument connecting the weighing platform)
1	← →	1
2	← →	2
3	← →	3
4	← →	4

2.7.4. Intrinsically Safe Analog 4-20 mA Output

The optional intrinsically safe analog 4-20 mA communication board connects to the COM2 port on the IND256x mainboard. It provides an intrinsically safe analog signal of 4-20 mA, proportional to the weight applied to the scale or to the rate of change of weight on the scale. The maximum cable length for the Analog Output connection is 300 m / 980 ft. The cable used for the analog output signal must be shielded.

- This option cannot be used together with WiFi option.



Figure 2-12: Intrinsically Safe Analog Output Option Board

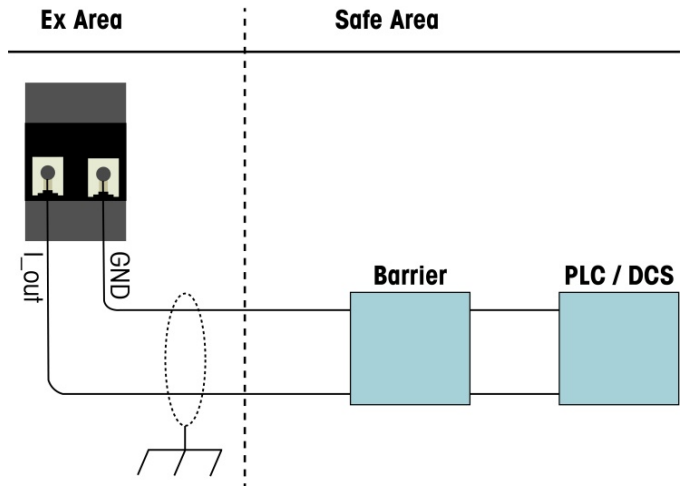

Figure 2-13: Analog Output Wiring

The KFD2-STC4-EX1 analog isolated barrier produced by P&F (certificate numbers: IECEx BAS 04.0016X; BAS 99 ATEX 7060X) has been verified and can be connected directly with the IND256x intrinsically safe analog 4-20 mA option, and then connected to a PLC or DCS system in the safe area.

2.7.5. Wireless Communication

IND256x wireless communication option board is installed on the mainboard with other option boards, and is not connected with peripherals. The option should be configured as described in Chapter 3, section 3.8.4. A strong WiFi signal is required to achieve wireless communication with peripherals.

The IND256x supports a single WiFi option.

- This option cannot be used together with the intrinsically safe analog 4-20 mA output option.

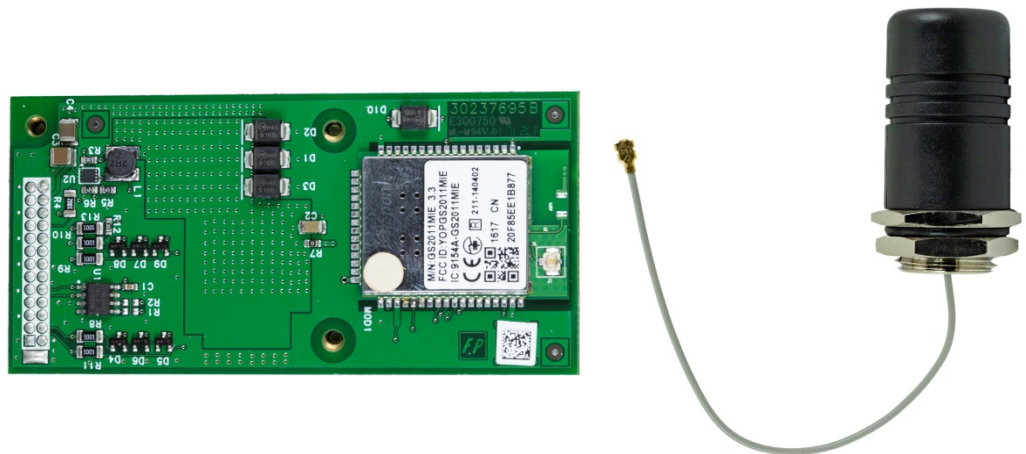

Figure 2-14: IND256x WiFi Option Board and Antenna

2.8. Sealing the Enclosure

When the IND256x terminal is used in a metrologically “approved” application, it must be protected from tampering by use of seals. IND256x versions include the optional sealing kit.

The method used for sealing will vary depending upon local requirements. The IND256x supports external sealing.

2.8.1. External Sealing of the Enclosure, US

IND256x lead seal details are shown in Figure 2-15. The procedure is as follows:

11. Determine that the correct area has been selected under **Scale > Type > Approval** and set the metrology switch SW1-1 to ON (refer to Chapter 2, **Operation**, for the location and function of this switch).
12. Pass the seal wire through two adjacent sealing bolts and then fix the seal retainer as shown in Figure 2-15.
13. Cut off the excessive lead seal wire.

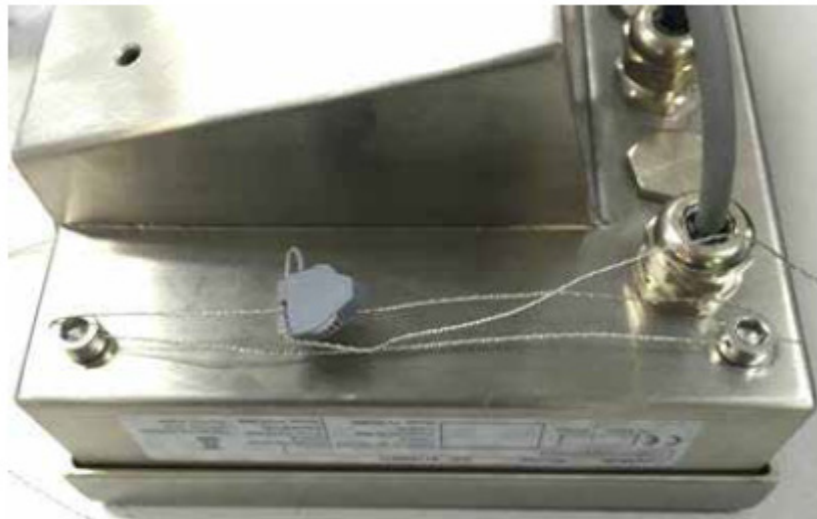

Figure 2-15: Sealing Method

2.9. Interface Parameters

2.9.1. Supply Circuit (Power Supply Port)

Supply circuit	Parameters
Variant with non-intrinsically safe AC-supply (Type key ends with “46” or “44”) (only ATEX & IECEx approved) Permanently connected cable with ferrule	Rated voltage: AC 187...250 V (50/60 Hz) Rated current: 125 mA Maximum input voltage: Um AC 250 V

Supply circuit	Parameters
Variant with non-intrinsically safe DC-supply (Type key ends with "56" or "54") (only ATEX & IECEx approved) Permanently connected cable with ferrule: Blue: +24V, Brown: gnd, Green-yellow: PE	Rated voltage: DC 18...30 V Rated current: 250 mA Maximum input voltage on associated apparatus: Um AC 250 V (Note: the rated voltage is lower)
Variants with intrinsically safe (battery) DC-supply (Type key ends with "25" or "27") Connection terminals: V+, GND, BATT, DATA	Nominal input voltage: DC 10 V Nominal input current: 350 mA
	Maximum input voltage: Ui DC 12.8 V Maximum input current: Ii 3.03 A Maximum input power: Pi 6.83 W
	Effective internal inductance: Li negligible Effective internal capacitance: Ci negligible

2.9.2. Intrinsically Safe RS232 Interface

Intrinsically safe RS232-interface	Parameters
Terminals J1.1 (TXD), J1.2(RXD) – J1.3 (GND)	Maximum input voltage: Ui DC ± 10 V Effective internal capacitance: Ci negligible Effective internal inductance: Li negligible
	Maximum output voltage: Uo DC J1.1-GND resp. J1.2-GND each: ± 5.36 V
	Maximum output current: Io J1.1-GND resp. J1.2-GND each: ± 12.9 mA
	Maximum output power: Po J1.1-GND resp. J1.2-GND each: 17.2 mW
	Maximum external capacitance: Co 100 nF Maximum external inductance: Lo 100 μ H

2.9.3. Intrinsically Safe Output for Connection to a Load Cell

Intrinsically safe output for connection to a load cell	Parameters
Terminals J5.1 (EXC+), J5.2 (SEN+), J5.3 (SIG+), J5.5 (SIG-), J5.6 (SEN-), J5.7 (EXC-)	Maximum output voltage: Uo DC 5.88 V Maximum output current: Io 171 mA Maximum output power: Po 940 mW
	Maximum external capacitance: Co 6.8 μ F Maximum external inductance: Lo 0.3 mH

2.9.4. Optional Communication Board Interfaces

Interfaces of the optional communication boards	Parameters
Intrinsically safe 4-20mA-interface Only for variants with analog output option board (Type key "A") Terminals J2.1 (I_OUT) – J2.2 (GND)	Maximum input voltage: U_i DC 3.5 V Maximum input current: I_i 115 mA Maximum internal capacitance: C_i 110nF Maximum internal inductance: $L_o=0$
	Maximum output voltage: U_o DC 13.65 V Maximum output current: I_o 115 mA Maximum output power: P_o 0.4 W Maximum external capacitance: C_o 680 nF Maximum external inductance: L_o 400 μ H
WiFi-antenna-connection Only for variants with Wifi option board (Type key "W") IPEX-connector for connection to the external antenna type AC-Q24-50ZD	Maximum RF-power: < 1.3 W Frequency: 2400...2483 MHz
Intrinsically safe active current loop-interface Only for variants with active current loop option board (type key "E") Terminal block J2, terminals J2.1...J2.4 (Active CL)	Maximum output voltage: U_o DC 5.36 V Maximum output current: I_o 131 mA Maximum output power: P_o 176 mW
	Maximum external capacitance: C_o 600 nF Maximum external inductance: L_o 400 μ H
Intrinsically safe passive current loop-interface Only for variants with passive current loop option board (type key "P") Terminal block J4, terminals J4.1...J4.4 (Passive CL)	Maximum input voltage: U_i DC 10 V Maximum input current: I_i 300 mA Maximum input power: P_i 500 mW
	Effective internal capacitance: C_i 110 nF Effective internal inductance: L_i negligible

2.9.5. Ambient Temperature Range

Parameters
Ambient temperature range: T_a -10 °C...+40 °C

METTLER TOLEDO Service

To protect your product's future:

Congratulations on choosing the quality and precision of METTLER TOLEDO. Proper use according to these instructions and regular calibration and maintenance by our factory-trained service team ensure dependable and accurate operation, protecting your investment. Contact us about a service agreement tailored to your needs and budget.

We invite you to register your product at www.mt.com/productregistration so we can contact you about enhancements, updates and important notifications concerning your product.

www.mt.com

For more information

Mettler-Toledo, LLC
1900 Polaris Parkway
Columbus, OH 43240

© 2020 Mettler-Toledo, LLC
30491430 Rev. 04, 01/2020



30491430