



TEST REPORT

Test Report No. : UL-RPT-RP-12474485-116-FCC

Applicant : Casambi Technologies Oy
Model No. : CBU-PWM4-4
FCC ID : 2ALA3-CBUASR
Technology : Bluetooth – Low Energy
Test Standard(s) : FCC Parts 15.207, 15.209 & 15.247

For details of applied tests refer to test result summary

1. This test report shall not be reproduced in full or partial, without the written approval of UL International Germany GmbH.
2. The results in this report apply only to the sample tested.
3. The test results in this report are traceable to the national or international standards.
4. Test Report Version 1.0
5. Result of the tested sample: **PASS**

Prepared by: Segun I, Adeniji
Title: Engineer
Date: 17.September.2018

Approved by: Ajit, Phadtare
Title: Lead Test Engineer
Date: 17.September.2018



Deutsche
Akkreditierungsstelle
D-PL-19381-02-00

This laboratory is accredited by DAkkS.
The tests reported herein have been performed in
accordance with its' terms of accreditation.

UL INTERNATIONAL GERMANY GMBH

Hedelfinger Str. 61
70327 Stuttgart, Germany
STU.CTECHLab@ul.com

This page has been left intentionally blank.

Table of Contents

1. Customer Information.....	4
1.1.Applicant Information	4
1.2.Manufacturer Information	4
2. Summary of Testing.....	5
2.1. General Information	5
Applied Standards	5
Location	5
Date information	5
2.2. Summary of Test Results	6
2.3. Methods and Procedures	6
2.4. Deviations from the Test Specification	6
3. Equipment Under Test (EUT)	7
3.1. Identification of Equipment Under Test (EUT)	7
3.2. Description of EUT	7
3.3. Modifications Incorporated in the EUT	7
3.4. Additional Information Related to Testing	8
3.5. Support Equipment	8
A. Support Equipment (In-house)	8
B. Support Equipment (Manufacturer supplied)	8
4. Operation and Monitoring of the EUT during Testing	9
4.1. Configuration and Peripherals	9
5. Measurements, Examinations and Derived Results	10
5.1. General Comments	10
5.2. Test Results	11
5.2.1. Transmitter AC Conducted Spurious Emissions	11
5.2.2. Transmitter Duty Cycle	15
5.2.3. Transmitter Radiated Emissions	17
5.2.4. Transmitter Band Edge Radiated Emissions	24
6. Measurement Uncertainty	28
7. Used equipment.....	29
8. Report Revision History	31

1. Customer Information

1.1.Applicant Information

Company Name:	Casambi Technologies Oy
Company Address:	Bertel Jungin aukio 1 E, Espoo, 02600 Finland
Company Phone No.:	+358 10 5012950
Company E-Mail:	support@casambi.com
Contact Person:	Mr. Kai Totterman
Contact E-Mail Address:	kai.totterman@casambi.com
Contact Phone No.:	+358 45 137 9988

1.2.Manufacturer Information

Company Name:	Casambi Technologies Oy
Company Address:	Bertel Jungin aukio 1 E, Espoo, 02600 Finland
Company Phone No.:	+358 10 5012950
Company E-Mail:	support@casambi.com
Contact Person:	Mr. Kai Totterman
Contact E-Mail Address:	kai.totterman@casambi.com
Contact Phone No.:	+358 45 137 9988

2. Summary of Testing

2.1. General Information

Applied Standards

Specification Reference:	47CFR15.247
Specification Title:	Code of Federal Regulations Volume 47 (Telecommunications): Part 15 Subpart C (Intentional Radiators) - Section 15.247
Specification Reference:	47CFR15.207 and 47CFR15.209
Specification Title:	Code of Federal Regulations Volume 47 (Telecommunications): Part 15 Subpart C (Intentional Radiators) - Sections 15.207 and 15.209
Test Firm Registration:	399704

Location

Location of Testing:	UL International Germany GmbH Hedelfinger Str. 61 70327 Stuttgart Germany
-----------------------------	--

Date information

Order Date:	21 August 2018
EUT arrived:	30 August 2018
Test Dates:	30 August 2018 to 07 September 2018
EUT returned:	-/-

2.2. Summary of Test Results

Clause	Measurement	Complied	Did not comply	Not performed	Not applicable
Part 15.207	Transmitter AC Conducted Emissions ⁽¹⁾	<input checked="" type="checkbox"/>	<input type="checkbox"/>	<input type="checkbox"/>	<input type="checkbox"/>
Part 15.247(a)(2)	Transmitter Minimum 6 dB Bandwidth	<input type="checkbox"/>	<input type="checkbox"/>	<input checked="" type="checkbox"/>	<input type="checkbox"/>
Part 15.247(e)	Transmitter Power Spectral Density	<input type="checkbox"/>	<input type="checkbox"/>	<input checked="" type="checkbox"/>	<input type="checkbox"/>
Part 15.247(b)(3)	Transmitter Maximum Peak Output Power	<input type="checkbox"/>	<input type="checkbox"/>	<input checked="" type="checkbox"/>	<input type="checkbox"/>
Part 15.247(d)/15.209(a)	Transmitter Radiated Emissions ⁽¹⁾	<input checked="" type="checkbox"/>	<input type="checkbox"/>	<input type="checkbox"/>	<input type="checkbox"/>
Part 15.247(d)/15.209(a)	Transmitter Band Edge Radiated Emissions ⁽¹⁾	<input checked="" type="checkbox"/>	<input type="checkbox"/>	<input type="checkbox"/>	<input type="checkbox"/>

Note(s):

1. Only tests covering the class 2 permissive change were required to be performed.

2.3. Methods and Procedures

Reference:	ANSI C63.10-2013
Title:	American National Standard of Procedures for Compliance Testing of Unlicensed Wireless Devices
Reference:	KDB 558074 D01 DTS Meas Guidance v04 April 5, 2017
Title:	Guidance for Performing Compliance Measurements on Digital Transmission Systems (DTS) Operating Under §15.247
Reference:	KDB 174176 D01 Line Conducted FAQ v01r01 June 3, 2015
Title:	AC Power-Line Conducted Emissions Frequently Asked Questions

2.4. Deviations from the Test Specification

For the measurements contained within this test report, there were no deviations from, additions to, or exclusions from the test specification identified above.

3. Equipment Under Test (EUT)

3.1. Identification of Equipment Under Test (EUT)

EUT Description:	Bluetooth controllable 4ch PWM dimmer
Brand Name:	Casambi
Model Name or Number:	CBU-PWM4-4
Test Sample Serial Number:	63DE0ACD7BDF (<i>Test sample for Radiated Emissions</i>)
Hardware Version Number:	CBU-PWM4-4 v1.3
Software/ Firmware Version Number:	24.1
FCC ID:	2ALA3-CBUASR

EUT Description:	Bluetooth controllable 4ch PWM dimmer
Brand Name:	Casambi
Model Name or Number:	CBU-PWM4-4
Test Sample Serial Number:	59B2297C1707 (<i>Test sample for AC conducted Emissions</i>)
Hardware Version Number:	CBU-PWM4-4 v1.3
Software/ Firmware Version Number:	24.1
FCC ID:	2ALA3-CBUASR

3.2. Description of EUT

The equipment under test was a Bluetooth controllable 4ch PWM dimmer.

3.3. Modifications Incorporated in the EUT

No modifications were applied to the EUT during testing.

3.4. Additional Information Related to Testing

Technology Tested:	Bluetooth Low Energy (Digital Transmission System)		
Type of Unit:	Transceiver		
Channel Spacing:	2 MHz		
Modulation:	GFSK		
Data Rate:	1 Mbps		
Power Supply Requirement(s):	Nominal	24 VDC	
Antenna Gain:	2 dBi		
Transmit Frequency Range:	2402 MHz to 2480 MHz		
Transmit Channels Tested:	Channel ID	RF Channel Number	Channel Frequency (MHz)
	Bottom	0	2402
	Middle	19	2440
	Top	39	2480

3.5. Support Equipment

The following support equipment was used to exercise the EUT during testing:

A. Support Equipment (In-house)

Item	Description	Brand Name	Model Name or Number	Serial Number
1	DC Power Cable (Length: 2 metres)	Not marked or stated	Not marked or stated	Not marked or stated
2				
3				

B. Support Equipment (Manufacturer supplied)

Item	Description	Brand Name	Model Name or Number	Serial Number
1	MP3 player	Apple	iPod Touch	CCQSCOZMGGK6
2				
3				

4. Operation and Monitoring of the EUT during Testing

The EUT was tested in the following operating mode(s):

Transmitting at maximum power in Bluetooth LE mode with modulation, maximum possible data length available.

4.1. Configuration and Peripherals

The EUT was tested in the following configuration(s):

- The EUT was powered using a 24 VDC power supply.
- Controlled in test mode using a software application Utility installed on the MP3 player supplied by the customer. The application was used to enable a continuous transmission and to select the test channels as required. The customer supplied a document containing the setup instructions "CBU-PWM4 Test Proposal Form FCC_ISED.docx" dated 30 August 2018.
- The EUT was made to transmit in the mode that results in the highest possible duty cycle.
- The EUT radiated sample was used for the measurement of Transmitter Radiated and Emissions Transmitter Band Edge Radiated Emissions.
- EMC32 V10.1.0 Software was used for the Radiated spurious emission measurement.

5. Measurements, Examinations and Derived Results

5.1. General Comments

Measurement uncertainties are evaluated in accordance with current best practice. Our reported expanded uncertainties are based on standard uncertainties, which are multiplied by an appropriate coverage factor to provide a statistical confidence level of approximately 95%. Please refer to Section 6 *Measurement Uncertainty* for details.

In accordance with DAkkS requirements all the measurement equipment is on a calibration schedule. All equipment was within the calibration period on the date of testing.

5.2. Test Results

5.2.1. Transmitter AC Conducted Spurious Emissions

Test Summary:

Test Engineer:	M. Asim Shahzad	Test Date:	30 August 2018
Test Sample Serial Number:	59B2297C1707		
Test Site Identification	SR 7/8		

Clause:	Part 15.207
Test Method:	ANSI C63.10 Section 6.2 / FCC KDB 174176 and notes below

Environmental Conditions:

Temperature (°C):	22
Relative Humidity (%):	33

Settings of the Instrument

Detector	Quasi Peak/ Average Peak
-----------------	--------------------------

Note(s):

1. The EUT was connected to an AC/DC Power Supply.
2. The AC/DC Power Supply was connected to a 120 VAC 60 Hz single phase supply via a LISN.
3. The final measured value, for the given emission, in the table below incorporates the cable loss.
4. All other emissions shown on the pre-scan plot were investigated and found to be ambient or >20 dB below the applicable limit or below the measurement system noise floor.
5. Measurements were performed in shielded room (SR7/ 8 Asset Number 1603671). The EUT was placed at a height of 80 cm above the reference ground plane and in a distance of 40 cm from the vertical ground plane at the edge of the table.
6. The device was configured to the test mode with a test program installed on the iPod.

Transmitter AC Conducted Spurious Emissions (continued)

Test setup:

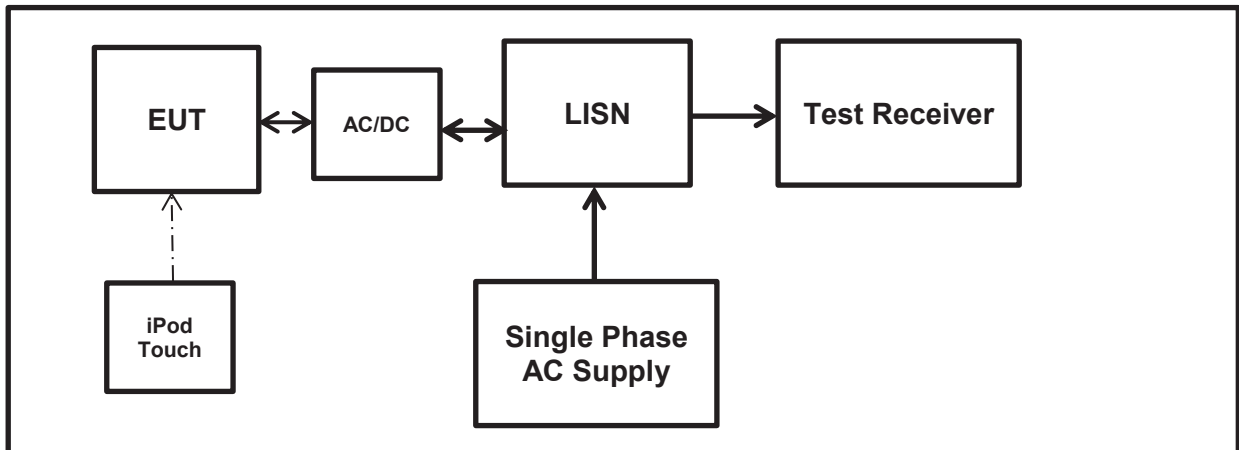

Results: Live / Quasi Peak

Frequency (MHz)	Line	Level (dB μ V)	Limit (dB μ V)	Margin (dB)	Result
0.16052	Live	40.2	65.4	25.2	Complied
0.17255	Live	39	64.8	25.8	Complied
0.1986	Live	42.7	63.7	21.0	Complied
0.24569	Live	32.3	61.9	29.6	Complied
2.40481	Live	35.8	56.0	20.2	Complied
20.18637	Live	32.1	60.0	27.9	Complied

Results: Live / Average

Frequency (MHz)	Line	Level (dB μ V)	Limit (dB μ V)	Margin (dB)	Result
0.16052	Live	19.8	55.4	35.6	Complied
0.17255	Live	20.2	54.8	34.6	Complied
0.19860	Live	32.8	53.7	20.9	Complied
0.24569	Live	16.7	51.9	35.2	Complied
2.40481	Live	20.5	46.0	25.5	Complied
20.18637	Live	25.8	50.0	24.2	Complied

Results: Neutral / Quasi Peak

Frequency (MHz)	Line	Level (dB μ V)	Limit (dB μ V)	Margin (dB)	Result
0.17355	Neutral	38.8	64.8	26.0	Complied
0.19208	Neutral	40.2	63.9	23.7	Complied
0.24168	Neutral	32.0	62.0	30.0	Complied
0.37044	Neutral	31.1	58.5	27.4	Complied
0.43006	Neutral	26.7	57.3	30.6	Complied
7.59920	Neutral	35.7	60.0	24.3	Complied

Results: Neutral / Average

Frequency (MHz)	Line	Level (dB μ V)	Limit (dB μ V)	Margin (dB)	Result
0.17355	Neutral	20.5	54.8	34.3	Complied
0.19208	Neutral	30.6	53.9	23.3	Complied
0.24168	Neutral	16.6	52.0	35.4	Complied
0.37044	Neutral	20.5	48.5	28.0	Complied
0.43006	Neutral	15.0	47.3	32.3	Complied
7.59920	Neutral	25.1	50.0	24.9	Complied

Result: Pass

Plot: Live and Neutral Line

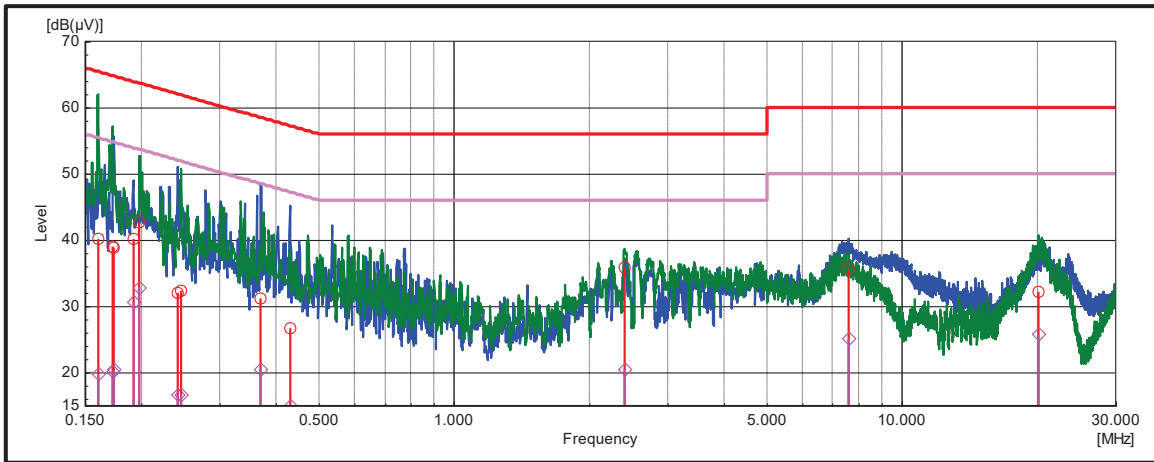

Note: These plots are pre-scans and for indication purposes only. For final measurements, see accompanying tables.

5.2.2. Transmitter Duty Cycle

Test Summary:

Test Engineer:	Abdoufataou, Salifou	Test Date:	30 August 2018
Test Sample Serial Number:	63DE0ACD7BDF		
Test Site Identification	SR 9		

FCC Reference:	Part 15.35(c)
Test Method Used:	FCC KDB 558074 Section 6.0

Environmental Conditions:

Temperature (°C):	22
Relative Humidity (%):	41

Note(s):

The transmitter duty cycle was measured using a spectrum analyser in the time domain and calculated by using the following calculation:

$10 \log (1 / (\text{On Time} / [\text{Period or } 100 \text{ ms whichever is the lesser}]))$.

BLE duty cycle: $10 \log (1 / (783.65 \mu\text{s} / 918.27 \mu\text{s})) = 0.69 \text{ dB}$

Test setup:

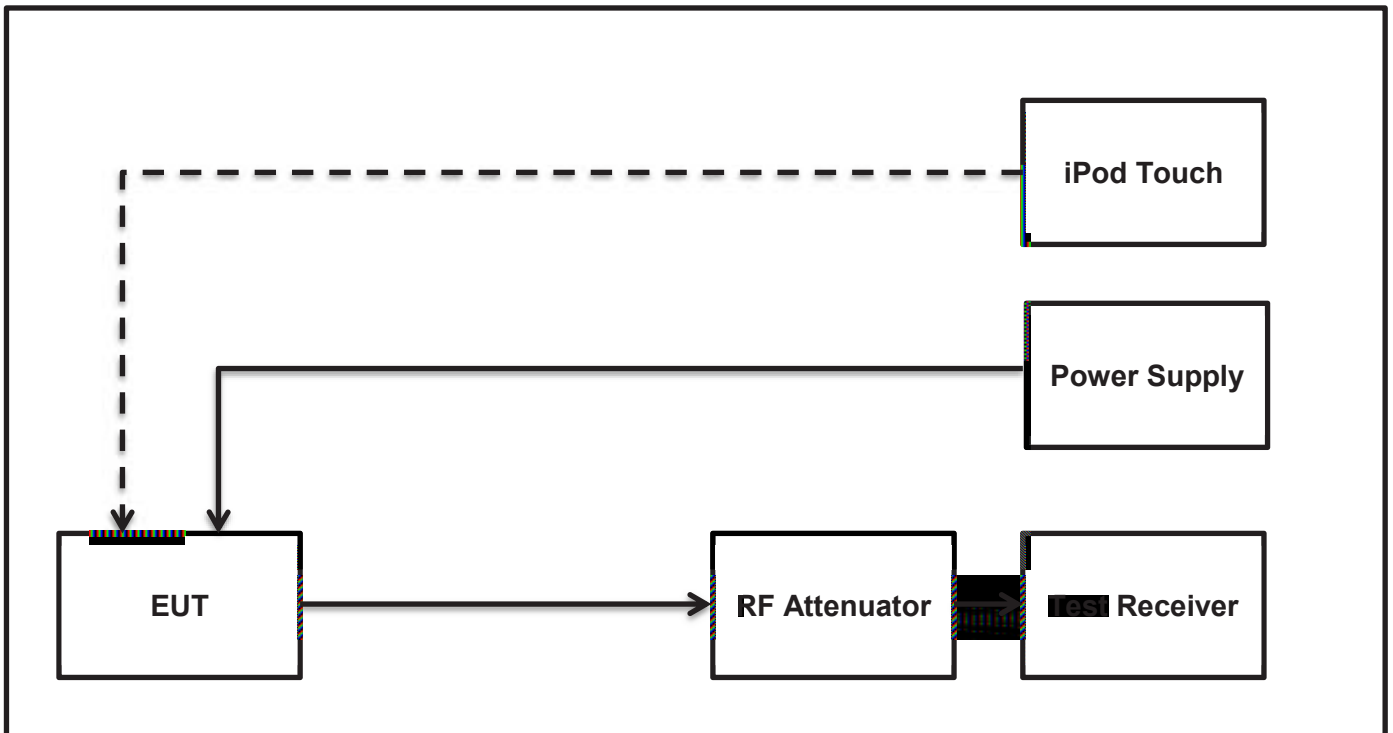

Transmitter Duty Cycle continued

Results:

Pulse Duration (µs)	Period (µs)	Duty Cycle Correction (dB)
783.65	918.27	0.69

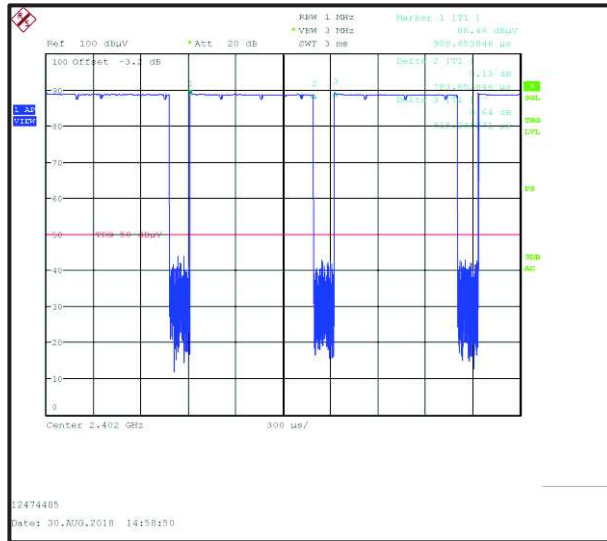

5.2.3. Transmitter Radiated Emissions**Test Summary:**

Test Engineer:	Abdoufataou, Salifou	Test Date:	30 August 2018
Test Sample Serial Number:	63DE0ACD7BDF		
Test Site Identification	SR 1/2		

FCC Reference:	Parts 15.247(d) & 15.209(a)
Test Method Used:	ANSI C63.10 Sections 6.3 and 6.5
Frequency Range	30 MHz to 1000 MHz

Environmental Conditions:

Temperature (°C):	20
Relative Humidity (%):	41

Note(s):

1. The final measured value, for the given emission, in the table below incorporates the calibrated antenna factor and cable loss.
2. The preliminary scans showed similar emission levels below 1 GHz, for each channel of operation. Therefore final radiated emissions measurements were performed with the EUT set to the bottom channel only.
3. Measurements below 1 GHz were performed in a semi-anechoic chamber at a distance of 3 metres. The EUT was placed at a height of 80 cm above the reference ground plane in the centre of the chamber turntable. Maximum emission levels were determined by height searching the measurement antenna over the range 1 metre to 4 metres.
4. Pre-scans were performed and markers placed on the highest measured levels. The test receiver resolution bandwidth was set to 100 kHz and video bandwidth 300 kHz. A peak detector was used, sweep time was set to auto and trace mode was Max Hold.
5. *In accordance with ANSI C63.10 Section 6.6.4.3, Note 1, if the peak measured value complies with the average limit, it is unnecessary to perform a quasi-peak measurement.

Test Setup:

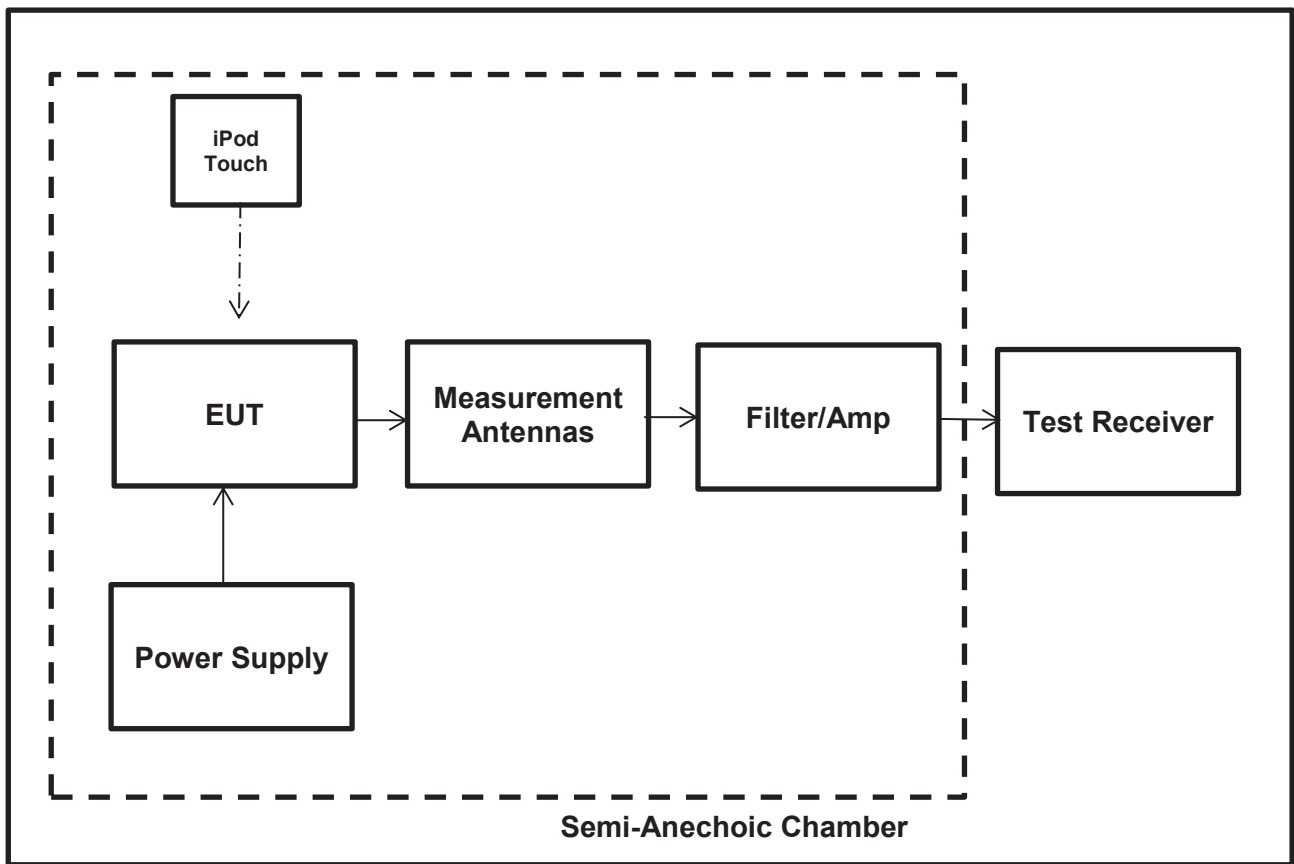

Results: Middle Channel

Frequency (MHz)	Antenna Polarization	Level (dBµV/m)	Limit (dBµV/m)	Margin (dB)	Result
57.22	V	14.98	40.00	25.02	Complied
113.74	V	14.94	40.00	25.06	Complied
124.99	V	15.12	40.00	24.88	Complied
491.43	H	22.69	46.00	23.31	Complied
655.54	H	26.75	46.00	19.25	Complied
951.83	H	31.48	46.00	14.52	Complied

Plot: 30 MHz – 1GHz

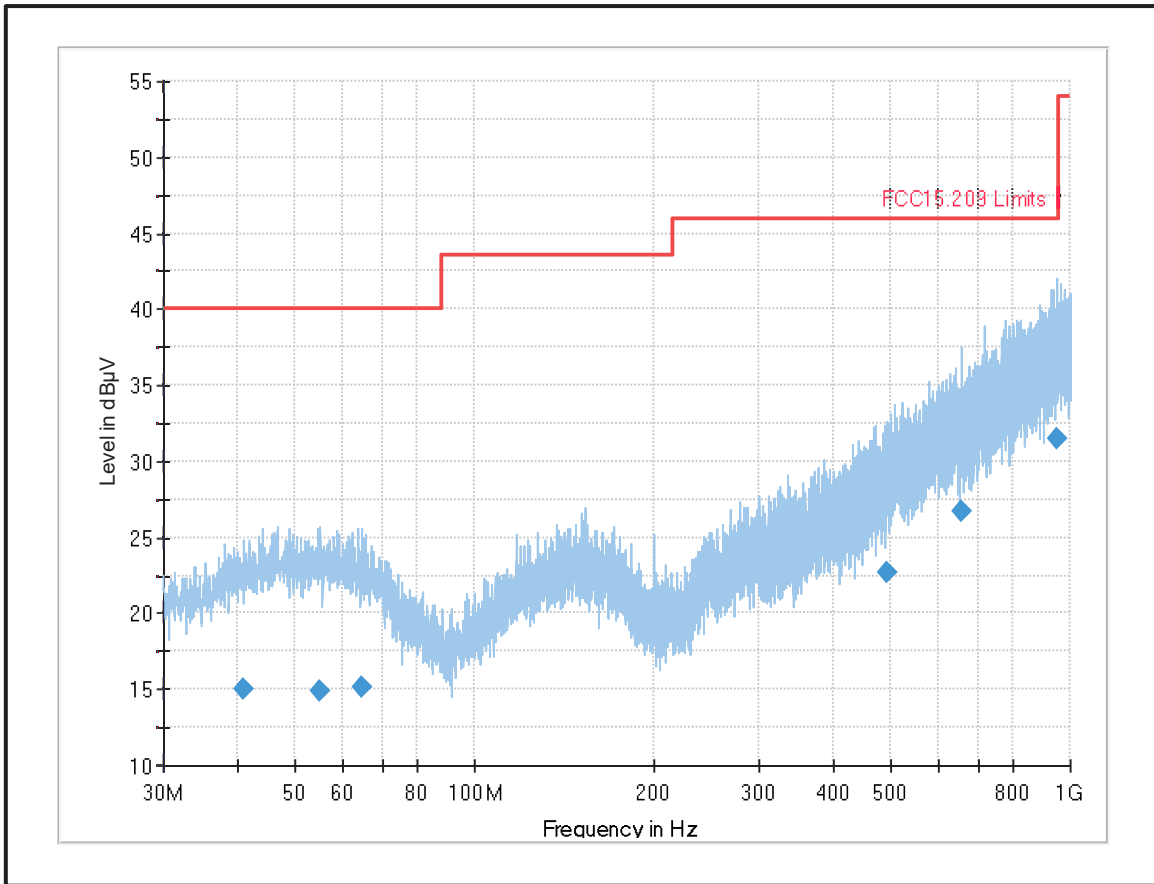

Note: This plot is a pre-scan and for indication purposes only. For final measurements, see accompanying table.

Result: Pass

Test Summary:

Test Engineer:	Abdoufataou, Salifou Segun I, Adeniji	Test Date:	30 August 2018 & 7 September 2018
Test Sample Serial Number:	63DE0ACD7BDF		
Test Site Identification	SR 1/2		

FCC Reference:	Parts 15.247(d) & 15.209(a)
Test Method Used:	FCC KDB 558074 Sections 11 & 12 referencing ANSI C63.10 Sections 6.3 and 6.6
Frequency Range	1 GHz to 25 GHz

Environmental Conditions:

Temperature (°C):	20
Relative Humidity (%):	40

Note(s):

1. The final measured value, for the given emission, in the table below incorporates the calibrated antenna factor and cable loss.
2. All the spurious emissions detected were re-investigated and re-measured with an average detector and in this case the emission was compared to the peak limit. For frequency range between 18 GHz and 25 GHz, no critical emission was found so only the measurement receiver noise floor level has been measured and recorded in the table The peak level was compared to the average limit as opposed to being compared to the peak limit because this is the more onerous limit. Only the middle channel plot was included in the report as similar result was obtained on both bottom and top channels.
3. The emission shown around the 2.4 GHz is the EUT fundamental.
4. Measurements above 1 GHz were performed in a semi-anechoic chamber at a distance of 3 metres. The EUT was placed at a height of 1.5 m above the reference ground plane in the centre of the chamber turntable. Maximum emission levels were determined by height searching the measurement antenna over the range 1 metre to 4 metres.
5. Pre-scans were performed and a marker placed on the highest measured level of the appropriate plot. The test receiver resolution bandwidth was set to 1 MHz and video bandwidth 3 MHz. The sweep time was set to auto.
6. *In accordance with ANSI C63.10 Section 6.6.4.3, Note 1, if the peak measured value complies with the average limit, it is unnecessary to perform an average measurement.
7. The reference level for the emission in the non-restricted band was established by following KDB 558074 Section 11.2 procedure.

Results:**Results: Peak / Bottom Channel**

Frequency (MHz)	Antenna Polarization	Level (dB μ V/m)	Limit (dB μ V/m)	Margin (dB)	Result
4802	Vertical	60.51	74.0	13.49	Complied

Results: Average / Bottom Channel

Frequency (MHz)	Antenna Polarization	Level (dB μ V/m)	Duty Cycle Correction Factor (dB)	Corrected Level (dB μ V/m)	Limit (dB μ V/m)	Margin (dB)	Result
4802	Vertical	51.35	0.69	52.04	54.0	1.96	Complied

Results: Peak / Middle Channel

Frequency (MHz)	Antenna Polarization	Level (dB μ V/m)	Limit (dB μ V/m)	Margin (dB)	Result
4880	Horizontal	55.25	74.0	18.75	Complied

Results: Average / Middle Channel

Frequency (MHz)	Antenna Polarization	Level (dB μ V/m)	Duty Cycle Correction Factor (dB)	Corrected Level (dB μ V/m)	Limit (dB μ V/m)	Margin (dB)	Result
4880	Horizontal	47.70	0.69	48.39	54.0	5.61	Complied

Results: Peak / Top Channel

Frequency (MHz)	Antenna Polarization	Level (dB μ V/m)	Average Limit (dB μ V/m)	Margin (dB)	Result
2608.0	Horizontal	50.94	54.0	20.73	Complied

Result: Pass

Plot: 1 GHz – 18GHz (Bottom channel) with Peak detector

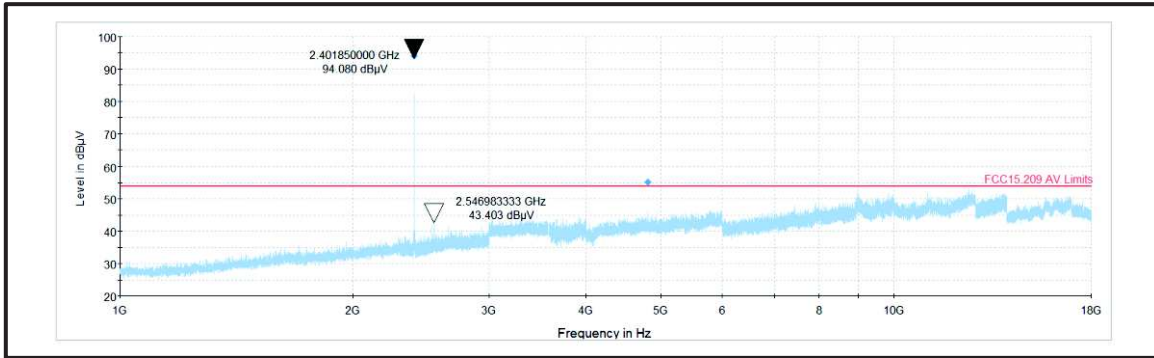

Plot: 1 GHz – 18GHz (Middle channel) with Peak detector

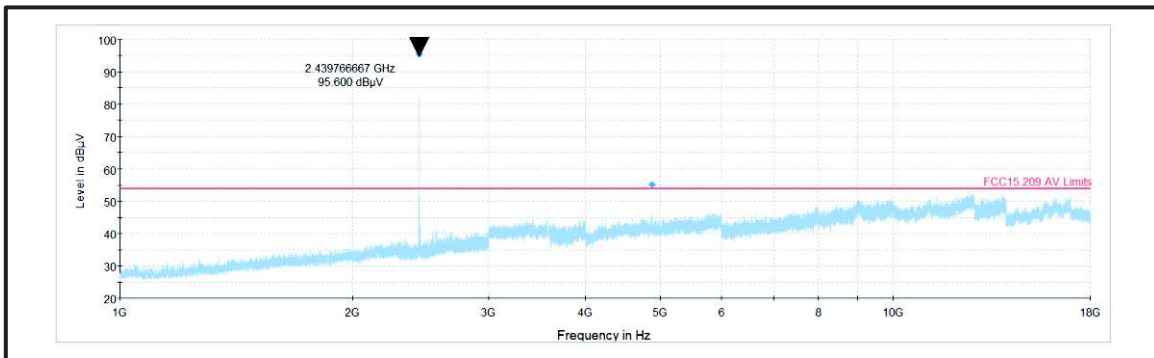

Plot: 1 GHz – 18GHz (Top channel) with Peak detector

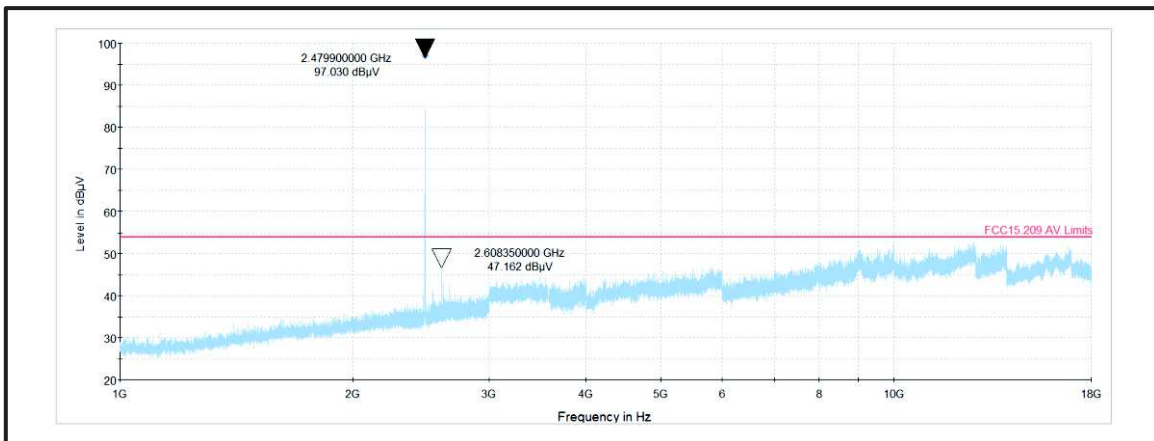

Note: The above plots are pre-scans with peak detector and for indication purposes only. For final measurements, see accompanying tables.

Plot: 18 GHz – 25GHz (Middle channel) with Peak detector

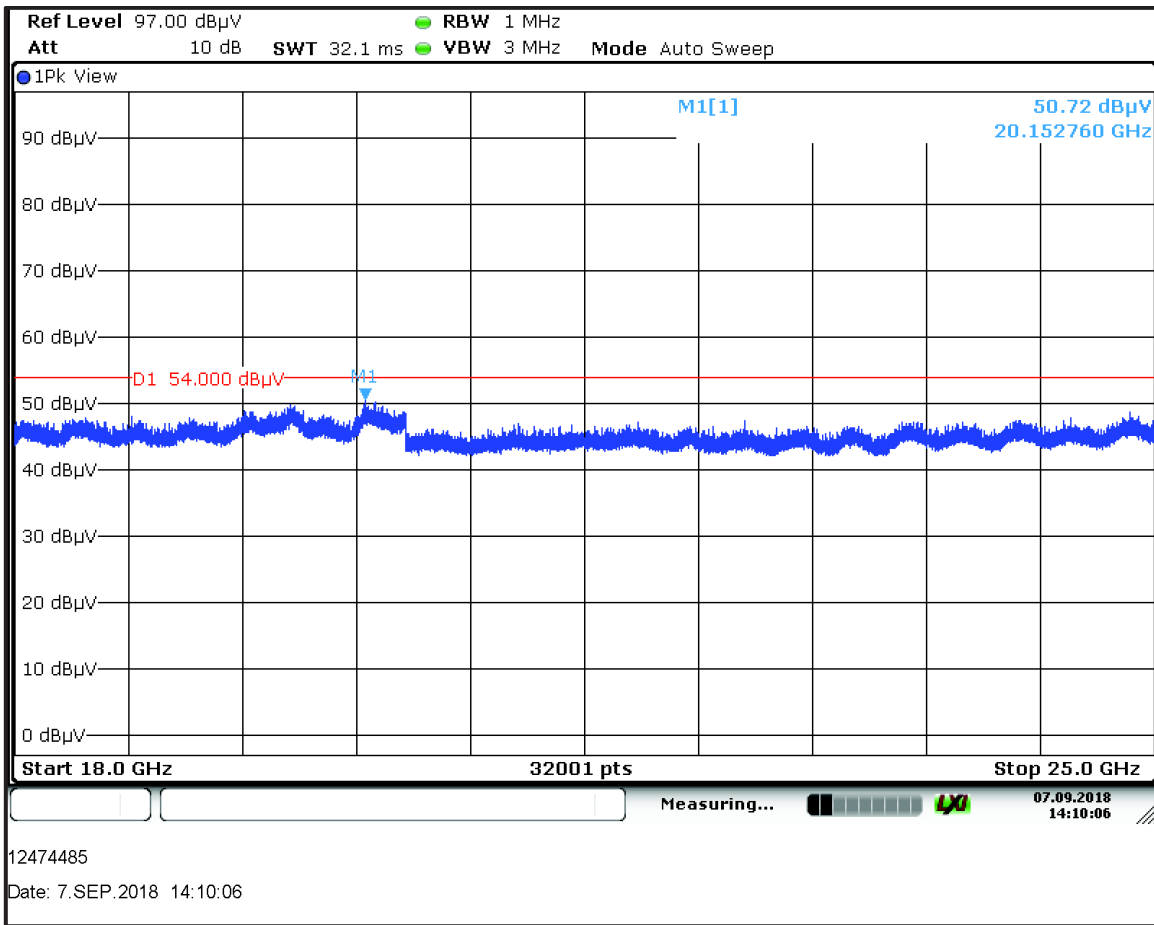

Note: The above plots are pre-scans with peak detector and for indication purposes only. For final measurements, see accompanying tables.

5.2.4. Transmitter Band Edge Radiated Emissions**Test Summary:**

Test Engineer:	Abdoufataou, Salifou	Test Date:	30 August 2018
Test Sample Serial Number:	63DE0ACD7BDF		
Test Site Identification	SR 1/2		

FCC Reference:	Parts 15.247(d) & 15.209(a)
Test Method Used:	ANSI C63.10 Section 6.10.4, 6.10.5 & KDB 558074 Section 11

Environmental Conditions:

Temperature (°C):	21
Relative Humidity (%):	40

Note(s):

- As the lower band edges fall within non-restricted bands, only peak measurements are required. In accordance with FCC KDB 558074 Section 11.1, the test method in Section 11.3 was followed: the test receiver resolution bandwidth was set to 100 kHz and video bandwidth 300 kHz. A peak detector was used, sweep time was set to auto and trace mode was Max Hold. The test receiver was left to sweep for a sufficient length of time in order to maximise the carrier level and out-of-band emissions. A marker and corresponding reference level line were placed on the peak of the carrier. As the maximum peak conducted output power was measured using a peak detector in accordance with FCC KDB 558074 Section 9.1.1 an out-of-band limit line was placed 20 dB below the peak level (FCC KDB 558074 Section 11.1(a)). A marker was placed on the band edge spot frequencies and a second marker placed on the highest emission level in the adjacent non-restricted band of operation (where a higher level emission was present). Marker frequencies and levels were recorded.
- As the upper band edge falls within a restricted band both peak and average measurements were recorded by placing a marker at the edge of the band. For peak measurements the test receiver resolution bandwidth was set to 1 MHz and the video bandwidth 3 MHz. A peak detector was used, sweep time was set to auto and trace mode was Max Hold. For average measurements the test receiver resolution bandwidth was set to 1 MHz and the video bandwidth 3 MHz. An average detector was used, sweep time was set to auto and trace mode was Max Hold. The test receiver was left to sweep for a sufficient length of time in order to maximise the carrier level and out-of-band emissions. A marker was placed on the band edge spot frequencies and a second marker placed on the highest emission level in the adjacent restricted band of operation (where a higher level emission was present). Marker frequencies and levels were recorded.
- There is a restricted band 10 MHz below the lower band edge. The test receiver was set up as follows: the RBW set to 1 MHz, the VBW set to 3 MHz, with the sweep time set to auto couple. Peak and average measurements were performed with their respective detectors. Markers were placed on the highest point on each trace.
- *Emissions in restricted bands: In accordance with C63.10 Section 6.6.4.3, Note 1, where the peak detected amplitude was shown to comply with the average limit, an average measurement was not performed.

Test Setup:

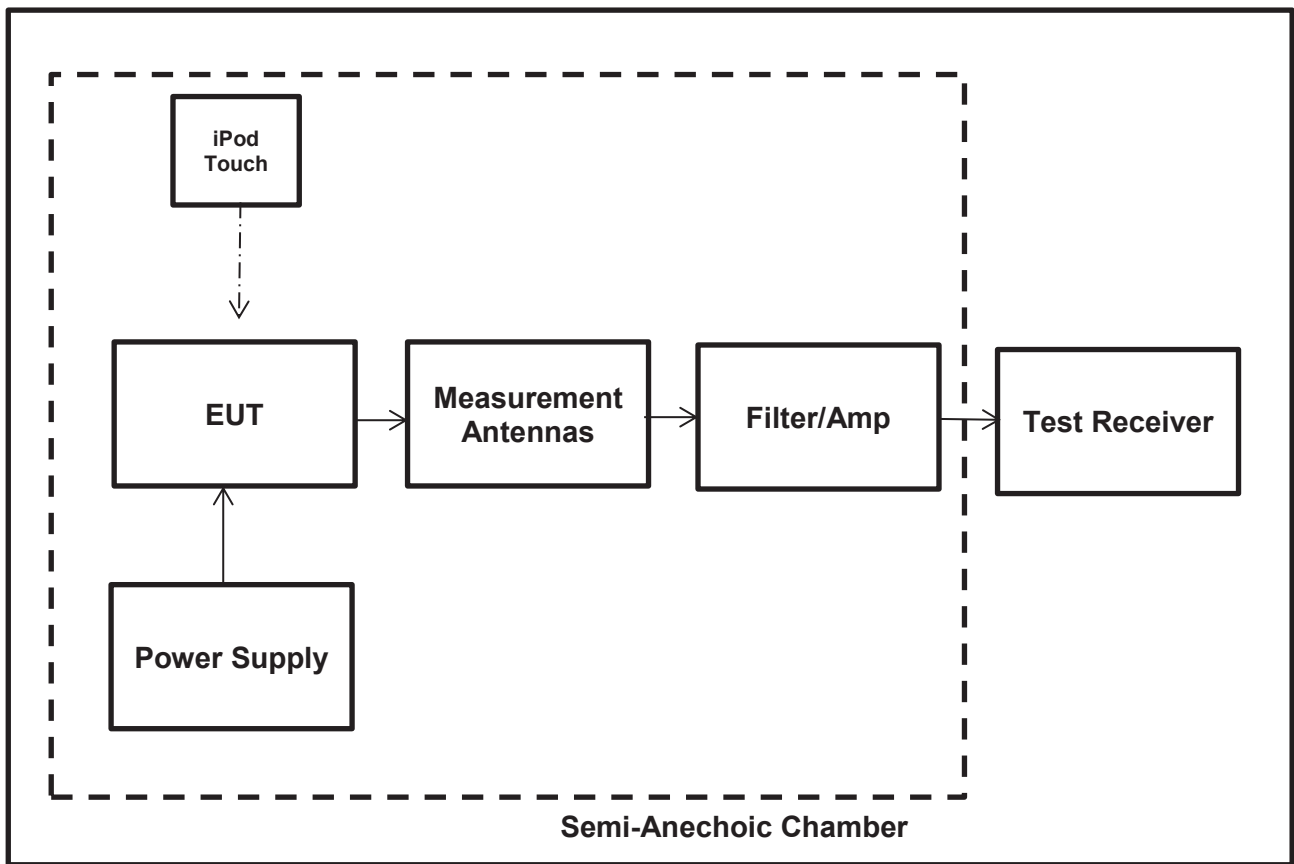

Transmitter Band Edge Radiated Emissions (continued)

Results: Lower Band Edge/Peak

Frequency (MHz)	Level (dBµV/m)	-20 dBc Limit (dBµV/m)	Margin (dB)	Result
2400.000	36.62	73.72	37.71	Complied

Results: Upper Band Edge / Restricted Band / Peak

Frequency (MHz)	Level (dBµV/m)	Limit (dBµV/m)	Margin (dB)	Result
2483.50	56.11	74.0	17.89	Complied

Results: Upper Band Edge / Restricted Band / Average

Frequency (MHz)	Average Level (dBµV/m)	Duty Cycle Correction Factor(dB)	Corrected Level (dBµV/m)	Limit (dBµV/m)	Margin (dB)	Result
2483.50	45.14	0.69	45.83	54.0	8.17	Complied

Results: 2310 to 2390 MHz Restricted Band / Peak

Frequency (MHz)	Peak Level (dBµV/m)	Limit (dBµV/m)	Margin (dB)	Result
2347.17	45.19	74.0	28.81	Complied

Results: 2310 to 2390 MHz Restricted Band / Average

Frequency (MHz)	Average Level (dBµV/m)	Duty Cycle Correction Factor(dB)	Corrected Level (dBµV/m)	Limit (dBµV/m)	Margin (dB)	Result
2389.35	36.50	0.69	37.29	54.0	16.71	Complied

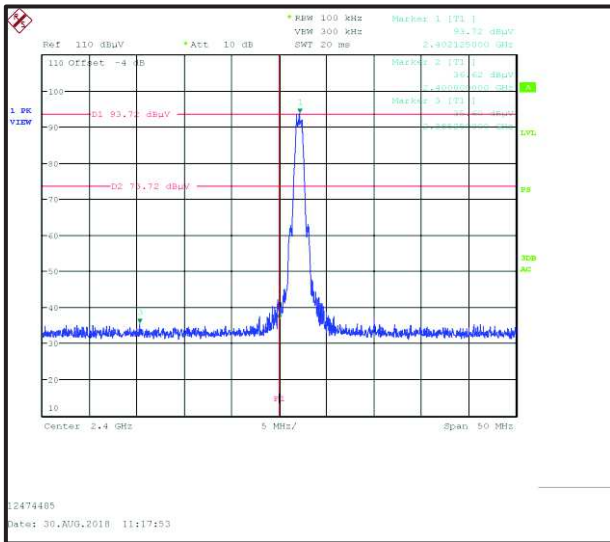

Lower Band Edge Peak Measurement

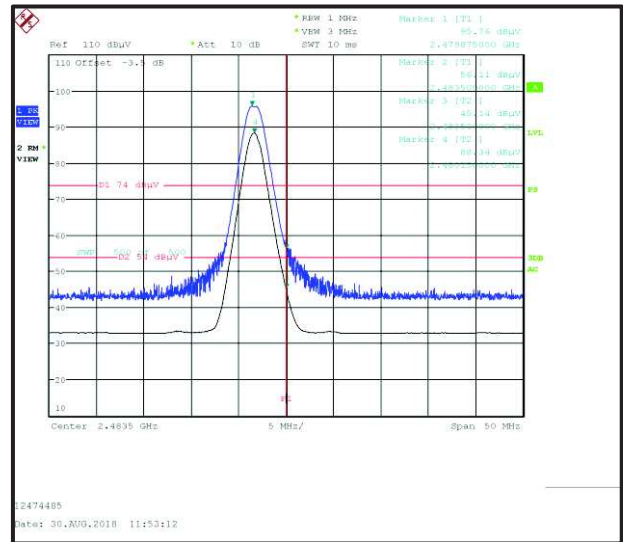

Upper Band Edge Peak & Average Measurement

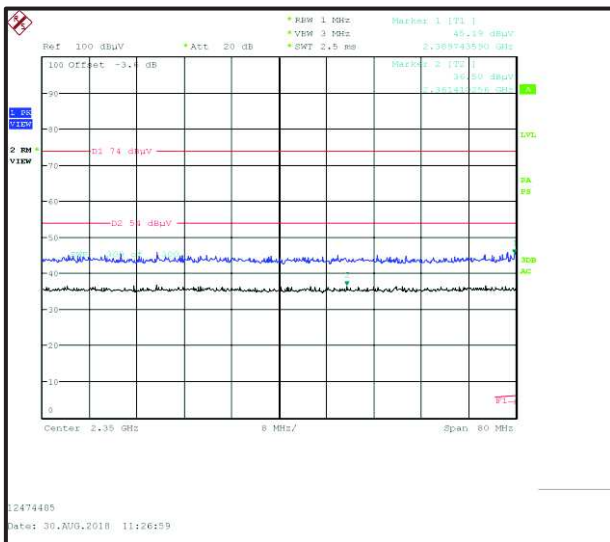

2310 MHz to 2390 MHz Restricted Band Plot

6. Measurement Uncertainty

The expression of uncertainty of a measurement result allows realistic comparison of results with reference values and limits given in specifications and standards.

The uncertainty of the result may need to be taken into account when interpreting the measurement results.

The reported expanded uncertainties below are based on a standard uncertainty multiplied by an appropriate coverage factor such that a confidence level of approximately 95% is maintained. For the purposes of this document “approximately” is interpreted as meaning “effectively” or “for most practical purposes”.

Measurement Type	Confidence Level (%)	Calculated Uncertainty
AC Conducted Spurious Emissions	95%	±2.49 dB
Radiated Spurious Emissions	95%	±3.10 dB
Band Edge Radiated Emissions	95%	±3.10 dB

The methods used to calculate the above uncertainties are in line with those recommended within the various measurement specifications. Where measurement specifications do not include guidelines for the evaluation of measurement uncertainty the published guidance of the appropriate accreditation body is followed.

7. Used equipment

Test site: SR 1/2

ID	Manufacturer	Type	Model	Serial No.	Calibration Date	Cal. Cycle
1	Rohde & Schwarz	Antenna, Loop	HFH2-Z2	831247/012	8/5/2016	36
103	EMCO	Antenna, Horn	3115	9008/3485	7/20/2016	36
104	EMCO	Antenna, Horn	3115	9008/3486	7/20/2016	36
156	Rohde & Schwarz	V-Network	ESH3-Z6	843864/004	7/11/2018	12
350	Rohde & Schwarz	Receiver, EMI Test	ESIB7	836697/014	7/12/2018	12
377	BONN Elektronik	Amplifier, Low Noise Pre	BLMA 0118-1A	025294B	7/12/2018	12
383	Rohde & Schwarz	Antenna, Rod	HFH2-Z1	890151/11	7/14/2017	24
423	Bonn Elektronik	Amplifier, Low Noise Pre	BLMA 1840-1A	055929	7/12/2018	12
424	EMCO	Antenna, Horn	EMCO 3116	00046537	7/28/2016	36s
425	Agilent	Generator, CW Signal	E8247C	MY43320849	7/10/2018	24
426	Agilent	Spectrum Analyzer	E4446A	US44020316	7/11/2018	24
460	Deisl	Turntable	DT 4250 S		n/a	n/a
465	Schwarzbeck	Antenna, Trilog Broadband	VULB 9168	9168-240	8/8/2016	36
474	Agilent	Analyzer, ENA Network	E5071C	MY46100912	7/13/2018	24
495	Rohde & Schwarz	Antenna, Log. - Periodical	HL050	100296	7/20/2016	36
496	Rohde & Schwarz	Antenna, log. - periodical	HL050	100297	7/20/2016	36
497	Schwarzbeck	Antenna, Biconical	VHBB 9124	423	7/7/2016	36
499	Schwarzbeck	Antenna, log.-per	VUSLP 9111	317	8/2/2016	36
587	Maturo	antenna mast, tilting	TAM 4.0-E	011/7180311	n/a	n/a
588	Maturo	Controller	NCD	029/7180311	n/a	n/a
591	Rohde & Schwarz	Receiver	ESU 40	100244/040	7/12/2018	12
607	Schwarzbeck	Antenna broadband horn antenna	BBHA 9170	9170-561	7/28/2016	36
608	Rohde & Schwarz	Switch Matrix	OSP 120	101227	4/8/2014	60
363	Wainwright	Notch Filter GSM900	WW-NF9	100002	Lab verification	n/a
611	Wainwright Instruments	Band Reject Filter DL LTE	WRCGV8-	1	Lab verification	n/a
612	Wainwright Instruments	Band Reject Filter UL LTE	WRCGV8-	1	Lab verification	n/a
613	Wainwright Instruments	Band Reject Filter WLAN/ BT	WRCTF12-	1	Lab verification	n/a
614	Wainwright Instruments	Highpass Filter 3GHz	WHKX10-	1	Lab verification	n/a
615	Wainwright Instruments	Highpass Filter 1GHz	WHKX12-	3	Lab verification	n/a
620	Bonn Elektronik	pre-amplifier	BLNA 0110-01N	1510111	7/12/2017	24
624	Wainwright	6 GHz high-pass filter	WHKX10-5850-6500-18000-40SS	5	Lab verification	n/a
628	Maturo	Antenna mast	CAM 4.0-P	224/19590716	n/a	n/a
629	Maturo	Kippeinrichtung	KE 2.5-R-M	MAT002	n/a	n/a

Test site: SR 9

ID	Manufacturer	Type	Model	Serial No.	Calibration Date	Cal. Cycle
424	EMCO	Antenna, Horn	EMCO 3116	00046537	7/28/2016	24
472	Rohde & Schwarz	Generator, Vektorsignal	SMU200A	102409	7/11/2018	12
592	Rohde & Schwarz	Wideband Radio Communication tester	CMW 500	119593	8/15/2017	12
622	Rohde & Schwarz	Step Attenuator	RSC	101904	7/12/2018	12
625	Schwarzbeck	Antenna, H-field	HFSL 7101	109	Verification - only relative measurements	n/a
626	Rohde & Schwarz	Bluetooth Tester	CBT	100481	Signaling Only	24
635	Rohde & Schwarz	Signal generator	SMB100A	179875	7/10/2018	12
636	Rohde & Schwarz	switching unit	OSP120	101698	7/12/2018	12
637	Rohde & Schwarz	Spectrum Analyzer	FSV40	101587	7/11/2018	12
423	Bonn Elektronik	Amplifier, Low Noise Pre	BLMA 1840-1A	55929	7/12/2018	24
451	Rohde & Schwarz	Power Meter, Dual Channel	NRVD	101190	7/10/2018	12
427	Rohde & Schwarz	Probe, Power Sensor	NRV-Z5	100106	7/12/2018	12
195	SPS	Power Supply	TOE8842-24	51455	Verified by Multimeter	12
216	Agilent	Multimeter	34401A	US36017458	7/11/2017	24
378	ESPEC/ Thermotec	Climatic Chamber	PL-1FT	5100869	8/9/2016	36

Test site: SR 7/8

ID	Manufacturer	Type	Model	Serial No.	Calibration Date	Cal. Cycle
22	Rohde & Schwarz	Artificial Mains	50 Ohm// 50uH	831767/014	7/11/2018	12
215	Rohde & Schwarz	Artificial Mains Network	9 kHz - 30 MHz; 3 phase	879675/002	7/11/2018	12
349	Rohde & Schwarz	Receiver, EMI Test	20 Hz - 7 GHz	836697/009	7/10/2018	12
616	Rohde & Schwarz	ISN	8 wire ISN for CAT6	101656	7/12/2018	12

8. Report Revision History

Version Number	Revision Details		
	Page No(s)	Clause	Details
1.0	-	-	Initial Version