

200.0 mm

210.0 mm



USER'S MANUAL | RLT5005-WV

Important Safety Precautions

When using your Bluetooth Speaker, basic safety precautions should always be followed, including the following:

1. READ ALL INSTRUCTIONS BEFORE USING YOUR SPEAKER.
2. Do not allow children or the infirm to play with your speaker without adult supervision.
3. Do not expose your speaker to excessive heat, flames or fire.
4. Always press all buttons carefully. Do not mishandle your speaker.
5. Do not use in extremely dry environments, as this can lead to static discharge during usage.
5. Do not expose your speaker to temperatures above 50°C. Keep out of direct sunlight.
7. Do not attempt to repair this product yourself. Contact a qualified service center if your speaker is in need of service.
8. Do not drop, puncture or expose your speaker to excessive trauma.
9. Your speaker is not intended for commercial use.
10. Use only the supplied charging cables. Unplug this device when not in use for long periods of time or during lightning storms.



BATTERY WARNING:

- The device is equipped with an integrated lithium ion battery. The battery cannot be replaced. Do not attempt to remove the battery from the device.
- Do not dispose of in fire or expose to excessive heat.
- Do not crush, puncture, incinerate, or short circuit external contacts.
- Please recycle or dispose of the battery properly. Contact your local recycling facilities and/or the manufacturer for further information.

Introduction

Thank you for purchasing the RealTree Bluetooth Speaker, item RLT5005-WV. You can use your speaker with most smartphones and Bluetooth devices to stream music and enjoy hands-free calling. In order to get the best results when using this device, please read this manual closely before using.

Package Contents

- RealTree Bluetooth Speaker
- USB Charging Cable
- User's Manual with Warranty Information

Specifications

Bluetooth Version: 5.0
 Bluetooth Range: Up to 33 Feet (10 Meters)
 Battery Type: 3.7 V 500 mAh Lithium Ion Battery
 Power Supply: 5V, 1A
 Charge Time: Approximately 2 Hours
 Play Time: Approximately 3 Hours*

*Applicable at 50% of maximum volume. Results will be lower when volume is higher.

A Quick Look at Your Device

1. Carry Strap
2. Speaker
3. Built-in Microphone
4. Micro USB Charging Cable
5. Charge Port Cover
6. Charging Port
7. LED Indicator Light
8. Power Button

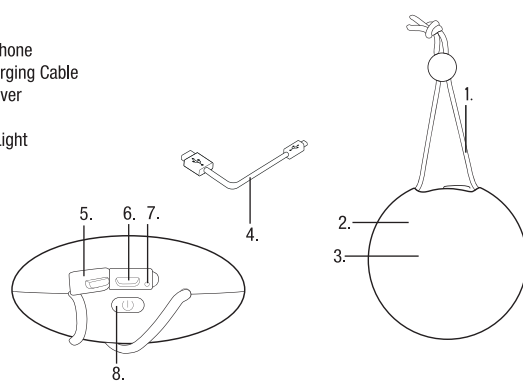

Charging Your Speaker

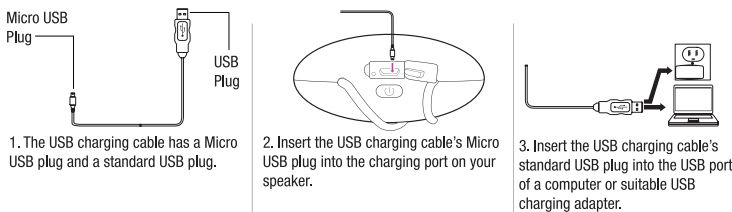

- (red) = Charging
- (off) = Charging Complete

4. The LED Indicator Light turns red while the speaker is charging then turns off once charging is complete.

NOTES:

- Charging can take approximately three hours to complete when the battery is fully drained.
- Remove the charging cable once charging is complete.
- Overcharging could reduce the life of the battery.
- A charged battery will lose its capacity if it is not used on a regular basis.

Important: To avoid a complete discharge of the battery, charge your speaker at least once every six months.

Bluetooth Pairing

PRESS & HOLD 2-3 SEC

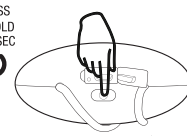

1. Press and hold the power button for 2-3 seconds to power on your speaker and go directly to pairing mode.

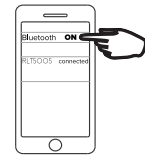

3. Go to the Bluetooth settings menu on your phone. Make sure that Bluetooth is turned on. Connect to the device listed as "RLT5005."

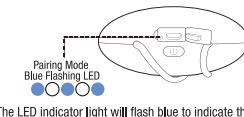

2. The LED indicator light will flash blue to indicate that your speaker is in pairing mode.

Enabling TWS pairing mode: (When you have 2 speakers)
 1) Power on 2 speakers simultaneously to initiate TWS pairing. When the speakers are self-paired they will make a beeping sound.

2) The main speaker LED will blink Blue and secondary speaker LED flashes solid Blue to indicate that both speakers are now ready to connect with your smart device.

*Before self-pairing, please ensure both speakers are not previously paired to other devices. No more than 2 speakers can be paired in TWS mode at the same time.

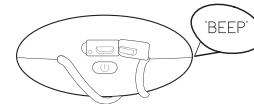

4. When Bluetooth is connected the speaker will make a beeping sound.

Using Your Speaker

PRESS & HOLD 2-3 SEC

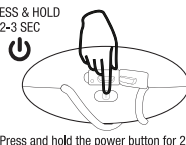

1. Press and hold the power button for 2-3 seconds to power on your speaker. If it has been previously paired to your Bluetooth device, it will automatically remain paired each time it is powered on.



4. Use your Bluetooth enabled device to dial out calls. The built-in microphone in the speaker will now act as a hands free device.

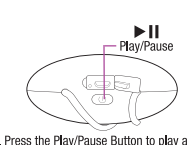

2. Press the Play/Pause Button to play a track. Press it again to pause a track.

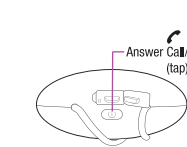

5. Tap the Answer button to answer an incoming call or end a call.

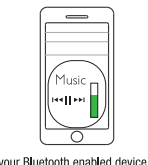

3. Use your Bluetooth enabled device to control the volume level and to change tracks on the speaker.

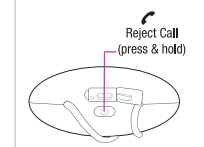

6. Press and hold the Answer button to reject an incoming call.

Maintenance and Care

-Use a soft cloth or paper towel to clean your speaker. Never use any harsh chemicals or detergents for cleaning. Make sure your speaker is dry before charging.

-When your speaker is not in use, they should be stored in a cool, dry place.

-Never tug or yank on the USB cable while it is connected to your speaker. Connect and disconnect cables as carefully as possible.

-Never expose your speaker to high temperatures, extreme cold.

-Please recycle or dispose of your speaker properly based on the laws and rules of your municipality. Contact local recycling facilities and/or the manufacturer of your speaker for further information.



Vivitar One Year Warranty

This warranty covers the original consumer purchaser only and is not transferable.

This warranty covers products that fail to function properly UNDER NORMAL USAGE, due to defects in material or workmanship. Your product will be repaired or replaced at no charge for parts or labor for a period of one year.

What Is Not Covered by Warranty

Damages or malfunctions not resulting from defects in material or workmanship and damages or malfunctions from other than normal use, including but limited to, repair by unauthorized parties, tampering, modification or accident.

To Obtain Warranty Service and Troubleshooting Information:

Call 1-800-592-9541 or visit our website at www.vivitar.com.

To receive warranty service along with the name and address of an authorized product service center, the original consumer purchaser must contact us for problem determination and service procedures. Proof of purchase in the form of a bill of sale or receipted invoice, evidencing that the product is within the applicable warranty period(s), MUST be presented in order to obtain the requested service. It is your responsibility to properly package and send any defective products along with a dated copy of proof of purchase, a written explanation of the problem, and a valid return address to the authorized service center at your expense. Do not include any other items or accessories with the defective product. Any products received by the authorized service center that are not covered by warranty will be returned unrepaid.

FCC Statement

FCCID: 2AL9B-RLT5005

Changes or modifications not expressly approved by the party responsible for compliance could void the user's authority to operate the equipment.

This device complies with Part 15 of the FCC Rules. Operation is subject to the following two conditions: (1) this device may not cause harmful interference, and (2) this device must accept any interference received, including interference that may cause undesired operation.

This equipment has been tested and found to comply with the limits for a Class B digital device, pursuant to Part 15 of the FCC Rules. These limits are designed to provide reasonable protection against harmful interference in a residential installation. This equipment generates, uses and can radiate radio frequency energy and, if not installed and used in accordance with the instructions, may cause harmful interference to radio communications. However, there is no guarantee that interference will not occur in a particular installation.

If this equipment does cause harmful interference to radio or television reception, which can be determined by turning the equipment off and on, the user is encouraged to try to correct the interference by one or more of the following measures:

- Reorient or relocate the receiving antenna.
- Increase the separation between the equipment and receiver.
- Connect the equipment into an outlet on a circuit different from that to which the receiver is connected.
- Consult the dealer or an experienced radio/TV technician for help.

The device has been evaluated to meet general RF exposure requirement. The device can be used in portable exposure condition without restriction.

Vivitar One Year Warranty (continued)

NO WARRANTIES, WHETHER EXPRESS OR IMPLIED, INCLUDING, BUT NOT LIMITED TO, ANY IMPLIED WARRANTIES OF MERCHANTABILITY OR FITNESS FOR A PARTICULAR PURPOSE, OTHER THAN THOSE EXPRESSLY DESCRIBED ABOVE, SHALL APPLY. DISTRIBUTOR FURTHER DISCLAIMS ALL WARRANTIES AFTER THE EXPRESS WARRANTY PERIOD STATED ABOVE. NO OTHER EXPRESS WARRANTY OR GUARANTY GIVEN BY ANY PERSON, FIRM OR ENTITY WITH RESPECT TO THE PRODUCT SHALL BE BINDING ON DISTRIBUTOR. REPAIR, REPLACEMENT, OR REFUND OF THE ORIGINAL PURCHASE PRICE - AT DISTRIBUTOR'S SOLE DISCRETION - ARE THE EXCLUSIVE REMEDIES OF THE CONSUMER. IN NO EVENT WILL DISTRIBUTOR, ITS MANUFACTURERS, OR SAKAR INT. BE LIABLE FOR ANY INCIDENTAL, DIRECT, INDIRECT, SPECIAL, PUNITIVE OR CONSEQUENTIAL DAMAGES (SUCH AS, BUT NOT LIMITED TO, DAMAGES FOR LOSS OF PROFITS, BUSINESS, SAVINGS, DATA OR RECORDS) CAUSED BY THE USE, MISUSE OR INABILITY TO USE THE PRODUCT. EXCEPT AS STATED HEREIN, NO OTHER WARRANTIES SHALL APPLY. NOTWITHSTANDING THE FOREGOING, CONSUMER'S RECOVERY AGAINST DISTRIBUTOR SHALL NOT EXCEED THE PURCHASE PRICE OF THE PRODUCT SOLD BY DISTRIBUTOR. THIS WARRANTY SHALL NOT EXTEND TO ANYONE OTHER THAN THE ORIGINAL CONSUMER WHO PURCHASED THE PRODUCT AND IS NOT TRANSFERABLE.

Some countries, states or provinces do not allow the exclusion or limitation of incidental or consequential damages or allow limitations on warranties, so limitation or exclusions may not apply to you. This warranty gives you specific legal rights, and you may have other rights that vary from state to state or province to province. Contact your authorized retailer to determine if another warranty applies.