



**CFR 47 FCC PART 15 SUBPART C**

**TEST REPORT**

*For*

**IP Camera**

**MODEL NUMBER: IPC2122LR3-F40W-E**

**ADDITIONAL NUMBER: IPC2122LR3-F40W-E-NB, IPC2122LR3-F60W-E,  
IPC2122LR3-F60W-E-NB, IPC2122LR3-F28W-E, IPC2122LR3-F28W-E-NB**

**FCC ID: 2AL8S-0235C3LJ**

**REPORT NUMBER: 4789043209-1**

**ISSUE DATE: Jul. 08, 2019**

*Prepared for*

**Zhejiang Uniview Technologies Co., Ltd.**

*Prepared by*

**UL-CCIC COMPANY LIMITED**

**No. 2, Chengwan Road, Suzhou Industrial Park, People's Republic of China**

**Tel: +86 769 22038881**

**Fax: +86 769 33244054**

**Website: [www.ul.com](http://www.ul.com)**



Revision History

<u>Rev.</u>	<u>Issue Date</u>	<u>Revisions</u>	<u>Revised By</u>
V0	07/08/2019	Initial Issue	



<b>Summary of Test Results</b>			
<b>Clause</b>	<b>Test Items</b>	<b>FCC/IC Rules</b>	<b>Test Results</b>
1	6dB Bandwidth	FCC Part 15.247 (a) (2)	Pass
2	Peak Conducted Output Power	FCC Part 15.247 (b) (3)	Pass
3	Power Spectral Density	FCC Part 15.247 (e)	Pass
4	Conducted Bandedge and Spurious Emission	FCC Part 15.247 (d)	Pass
5	Radiated Bandedge and Spurious Emission	FCC Part 15.247 (d) FCC Part 15.209 FCC Part 15.205	Pass
6	Conducted Emission Test For AC Power Port	FCC Part 15.207	Pass
7	Antenna Requirement	FCC Part 15.203	Pass



## TABLE OF CONTENTS

<b>1. ATTESTATION OF TEST RESULTS .....</b>	<b>6</b>
<b>2. TEST METHODOLOGY .....</b>	<b>8</b>
<b>3. FACILITIES AND ACCREDITATION .....</b>	<b>8</b>
<b>4. CALIBRATION AND UNCERTAINTY .....</b>	<b>9</b>
4.1. <i>MEASURING INSTRUMENT CALIBRATION .....</i>	<i>9</i>
4.2. <i>MEASUREMENT UNCERTAINTY.....</i>	<i>9</i>
<b>5. EQUIPMENT UNDER TEST .....</b>	<b>10</b>
5.1. <i>DESCRIPTION OF EUT .....</i>	<i>10</i>
5.2. <i>MAXIMUM OUTPUT POWER.....</i>	<i>11</i>
5.3. <i>CHANNEL LIST .....</i>	<i>11</i>
5.4. <i>TEST CHANNEL CONFIGURATION.....</i>	<i>11</i>
5.5. <i>THE WORSE CASE CONFIGURATIONS.....</i>	<i>11</i>
5.6. <i>DESCRIPTION OF AVAILABLE ANTENNAS .....</i>	<i>12</i>
5.7. <i>THE WORSE CASE CONFIGURATIONS.....</i>	<i>12</i>
5.8. <i>DESCRIPTION OF TEST SETUP.....</i>	<i>13</i>
<b>6. MEASURING INSTRUMENT AND SOFTWARE USED .....</b>	<b>14</b>
<b>7. MEASUREMENT METHODS .....</b>	<b>15</b>
<b>8. ANTENNA PORT TEST RESULTS .....</b>	<b>16</b>
8.1. <i>ON TIME AND DUTY CYCLE.....</i>	<i>16</i>
8.2. <i>6 dB DTS BANDWIDTH.....</i>	<i>19</i>
8.2.1. <i>802.11b MODE .....</i>	<i>20</i>
8.2.2. <i>802.11g MODE .....</i>	<i>22</i>
8.2.3. <i>802.11n HT20 MODE .....</i>	<i>24</i>
8.2.4. <i>802.11n HT40 MODE .....</i>	<i>26</i>
8.3. <i>PEAK CONDUCTED OUTPUT POWER.....</i>	<i>28</i>
8.3.1. <i>802.11b MODE .....</i>	<i>29</i>
8.3.2. <i>802.11g MODE .....</i>	<i>29</i>
8.3.3. <i>802.11n HT20 MODE .....</i>	<i>29</i>
8.3.4. <i>802.11n HT40 MODE .....</i>	<i>29</i>
8.4. <i>POWER SPECTRAL DENSITY .....</i>	<i>30</i>
8.4.1. <i>802.11b MODE .....</i>	<i>31</i>
8.4.2. <i>802.11g MODE .....</i>	<i>33</i>
8.4.3. <i>802.11n HT20 MODE .....</i>	<i>35</i>
8.4.1. <i>802.11n HT40 MODE .....</i>	<i>37</i>
8.5. <i>CONDUCTED BANDEDGE AND SPURIOUS EMISSIONS.....</i>	<i>39</i>
8.5.1. <i>802.11b MODE .....</i>	<i>41</i>



---

8.5.2.	802.11g MODE .....	47
8.5.1.	802.11n HT20 MODE .....	53
8.5.1.	802.11n HT40 MODE .....	59
<b>9.</b>	<b>RADIATED TEST RESULTS.....</b>	<b>65</b>
9.1.	<i>RESTRICTED BANDEDGE</i> .....	71
9.1.1.	802.11b MODE .....	72
9.1.2.	802.11g MODE .....	76
9.1.3.	802.11n HT20 MODE .....	80
9.1.1.	802.11n HT40 MODE .....	84
9.2.	<i>SPURIOUS EMISSIONS (1~18GHz)</i> .....	88
9.2.1.	802.11b MODE .....	88
9.2.2.	802.11g MODE .....	94
9.2.3.	802.11n HT20 MODE .....	100
9.2.4.	802.11n HT40 MODE .....	106
9.3.	<i>SPURIOUS EMISSIONS (18~26GHz)</i> .....	112
9.3.1.	802.11b MODE .....	112
9.4.	<i>SPURIOUS EMISSIONS (0.03 ~ 1 GHz)</i> .....	114
9.4.1.	802.11b MODE .....	114
9.5.	<i>SPURIOUS EMISSIONS BELOW 30M</i> .....	116
9.5.1.	802.11b MODE .....	116
<b>10.</b>	<b>AC POWER LINE CONDUCTED EMISSIONS .....</b>	<b>119</b>
10.1.	802.11b MODE.....	120
<b>11.</b>	<b>ANTENNA REQUIREMENTS .....</b>	<b>122</b>



## 1. ATTESTATION OF TEST RESULTS

### Applicant Information

Company Name: Zhejiang Uniview Technologies Co., Ltd.  
Address: 88 JIANGLING RD, BINJIANG DISTRICT, HANGZHOU,  
ZHEJIANG 310051 CHINA

### Manufacturer Information

Company Name: Zhejiang Uniview Technologies Co., Ltd.  
Address: 88 JIANGLING RD, BINJIANG DISTRICT, HANGZHOU,  
ZHEJIANG 310051 CHINA

### Factory Information

Factory 1:  
Company Name: Zhejiang Uniview Systems Technology Co.,Ltd.  
Address: No.1277 South Qingfeng South Road, Tongxiang City, Jiaxing City

Factory 2:  
Company Name: TDG Technology Co.,Ltd.  
Address: YATAI ROAD NO.1, NANHU DISTRICT, JIAXING,  
ZHEJIANG, 314050, CHINA

Factory 3:  
Company Name: SUZHOU QIAOXIN ELECTRONIC Technology Co.,Ltd.  
Address: NO.77,YITANG ROAD,ECONOMIC DEVELOPMENT  
ZONE,WUJIANG DISTRICT, SUZHOU JIANGSU CHINA

### EUT Description

EUT Name: IP Camera  
Model: IPC2122LR3-F40W-E  
Additional Number: IPC2122LR3-F40W-E-NB, IPC2122LR3-F60W-E, IPC2122LR3-F60W-E-NB, IPC2122LR3-F28W-E, IPC2122LR3-F28W-E-NB  
Sample Number: 2343850  
Sample Received Date: May 16, 2019  
Date of Tested: May 16~ June 10, 2019



APPLICABLE STANDARDS	
STANDARD	TEST RESULTS
CFR 47 FCC PART 15 SUBPART C	PASS

Prepared By:

*Tom Tang*

Checked By:

*Chris Zhong*

---

Tom Tang  
Engineer Project Associate

---

Chris Zhong  
Senior Project Engineer

Approved By:

*Scholl Zhang*

---

Scholl Zhang  
Laboratory Leader



## 2. TEST METHODOLOGY

The tests documented in this report were performed in accordance with KDB 558074 D01 15.247 Meas Guidance v05r02, KDB 414788 D01 Radiated Test Site v01r01, CFR 47 FCC Part 2, CFR 47 FCC Part 15, ANSI C63.10-2013.

## 3. FACILITIES AND ACCREDITATION

Accreditation Certificate	<p><b>A2LA (Certificate No.: 4829.01)</b>  <b>UL-CCIC COMPANY LIMITED has been assessed and proved to be in compliance with A2LA.</b></p> <p><b>FCC (FCC Designation No.: CN1247)</b>  <b>UL-CCIC COMPANY LIMITED has been recognized to perform compliance testing on equipment subject to the Commission's Declaration of Conformity (DoC) and Certification rules</b></p>
---------------------------	--

Note 1: All tests measurement facilities use to collect the measurement data are located at No. 2, Chengwan Road, Suzhou Industrial Park, Suzhou 215122, People's Republic of China

Note 2: For below 30MHz, lab had performed measurements at test anechoic chamber and comparing to measurements obtained on an open field site. These measurements below 30MHz had been correlated to measurements performed on an OFS.

Note 3: The test anechoic chamber in UL-CCIC COMPANY LIMITED had been calibrated and compared to the open field sites and the test anechoic chamber is shown to be equivalent to or worst case from the open field site.





## 4. CALIBRATION AND UNCERTAINTY

### 4.1. MEASURING INSTRUMENT CALIBRATION

The measuring equipment utilized to perform the tests documented in this report has been calibrated in accordance with the manufacturer's recommendations, and is traceable to recognize national standards.

### 4.2. MEASUREMENT UNCERTAINTY

Where relevant, the following measurement uncertainty levels have been estimated for tests performed on the apparatus:

Test Item	Uncertainty
Conduction emission	3.80dB
Radiation Emission test(include Fundamental emission) (9KHz-30MHz)	3.32dB
Radiation Emission test(include Fundamental emission) (30MHz-1GHz)	3.27dB
Radiation Emission test (1GHz to 26GHz)( include Fundamental emission)	3.72dB (1GHz-18Gz)
	4.11dB (18GHz-26Gz)
Note: This uncertainty represents an expanded uncertainty expressed at approximately the 95% confidence level using a coverage factor of k=2.	



## 5. EQUIPMENT UNDER TEST

### 5.1. DESCRIPTION OF EUT

EUT Name	IP Camera
Model	IPC2122LR3-F40W-D
Radio Technology	IEEE802.11b/g/n HT20&HT40
Operation frequency	IEEE 802.11b: 2412MHz—2462MHz IEEE 802.11g: 2412MHz—2462MHz IEEE 802.11n HT20: 2412MHz—2462MHz IEEE 802.11n HT40: 2422MHz—2452MHz
Modulation	IEEE 802.11b: DSSS(CCK) IEEE 802.11g: OFDM(64QAM, 16QAM, QPSK, BPSK) IEEE 802.11n HT20: OFDM (64QAM, 16QAM, QPSK,BPSK) IEEE 802.11n HT40: OFDM (64QAM, 16QAM, QPSK,BPSK)
Power Supply	DC 12V

Remark:

Model No.:

Number	Name	Number	Name	Number:	Name
1	IPC2122LR3-F40W-E	2	IPC2122LR3-F60W-E	3	IPC2122LR3-F28W-E
4	IPC2122LR3-F40W-E-NB	5	IPC2122LR3-F60W-E-NB		IPC2122LR3-F28W-E-NB

Only the main model IPC2122LR3-F40W-E is tested and only the data of this model is shown in this test report. Since have the same technical construction including circuit diagram, PCB Layout, components and component layout, all electrical construction and mechanical construction with IPC2122LR3-F40W-E. The difference lies only for model designation, different sales markets and consumer.



## 5.2. MAXIMUM OUTPUT POWER

Number of Transmit Chains (NTX)	IEE Std. 802.11	Frequency (MHz)	Channel Number	Max PK Conducted Power (dBm)
1	IEEE 802.11b	2412-2462	1-11[11]	14.03
1	IEEE 802.11g	2412-2462	1-11[11]	18.04
1	IEEE 802.11nHT20	2412-2462	1-11[11]	17.14
1	IEEE 802.11nHT40	2422-2452	3-9[7]	16.70

## 5.3. CHANNEL LIST

Channel List for 802.11b/g/n (20 MHz)							
Channel	Frequency (MHz)	Channel	Frequency (MHz)	Channel	Frequency (MHz)	Channel	Frequency (MHz)
1	2412	4	2427	7	2442	10	2457
2	2417	5	2432	8	2447	11	2462
3	2422	6	2437	9	2452	/	/

Channel List for 802.11n (40 MHz)							
Channel	Frequency (MHz)	Channel	Frequency (MHz)	Channel	Frequency (MHz)	Channel	Frequency (MHz)
3	2422	5	2432	7	2442	9	2452
4	2427	6	2437	8	2447	/	/

## 5.4. TEST CHANNEL CONFIGURATION

Test Mode	Test Channel	Frequency
WiFi TX(802.11b)	CH 1, CH 6, CH 11	2412MHz, 2437MHz, 2462MHz
WiFi TX(802.11g)	CH 1, CH 6, CH 11	2412MHz, 2437MHz, 2462MHz
WiFi TX(802.11n HT20)	CH 1, CH 6, CH 11	2412MHz, 2437MHz, 2462MHz
WiFi TX(802.11n HT40)	CH 3, CH 6, CH 9	2422MHz, 2437MHz, 2452MHz

## 5.5. THE WORSE CASE CONFIGURATIONS

The Worst Case Power Setting Parameter under 2400 ~ 2483.5MHz Band							
Test Software		SecureCRT					
Modulation Mode	Transmit Antenna Number	Test Channel					
		NCB: 20MHz			NCB: 40MHz		
		CH 1	CH 6	CH 11	CH 3	CH 6	CH 9
802.11b	1	N/A	N/A	N/A	/		
802.11g	1	N/A	N/A	N/A			
802.11n HT20	1	N/A	N/A	N/A			
802.11n HT40	1	/			N/A	N/A	N/A



## 5.6. DESCRIPTION OF AVAILABLE ANTENNAS

Antenna	Frequency (MHz)	Antenna Type	MAX Antenna Gain (dBi)
1	2412-2462	Internal Antenna	2.69

Test Mode	Transmit and Receive Mode	Description
IEEE 802.11b	<input checked="" type="checkbox"/> 1TX, 1RX	ANT 1 can be used as transmitting/receiving antenna.
IEEE 802.11g	<input checked="" type="checkbox"/> 1TX, 1RX	ANT 1 can be used as transmitting/receiving antenna.
IEEE 802.11n HT20	<input checked="" type="checkbox"/> 1TX, 1RX	ANT 1 can be used as transmitting/receiving antenna.
IEEE 802.11n HT40	<input checked="" type="checkbox"/> 1TX, 1RX	ANT 1 can be used as transmitting/receiving antenna.

## 5.7. THE WORSE CASE CONFIGURATIONS

For the product, there is only one transmission antenna, so only the worst data for the antenna is recorded in the report.

Worst-case data rates as provided by the client were:

802.11b mode: 1 Mbps  
802.11b mode: 6 Mbps  
802.11n HT20 mode: MCS0  
802.11n HT40 mode: MCS0

## 5.8. DESCRIPTION OF TEST SETUP

### SUPPORT EQUIPMENT

Item	Equipment	Brand Name	Model Name	P/N
1	Laptop	ThinkPad	E550c	N/A

### I/O CABLES

Cable No	Port	Connector Type	Cable Type	Cable Length(m)	Remarks
1	LAN	LAN	LAN	1	N/A

### ACCESSORIES

Item	Accessory	Brand Name	Model Name	Description
1	Adapter	GUCF	UWP-24W-1220T	N/A

### TEST SETUP

The EUT can work in engineering mode with a software through a Laptop.

### SETUP DIAGRAM FOR TESTS

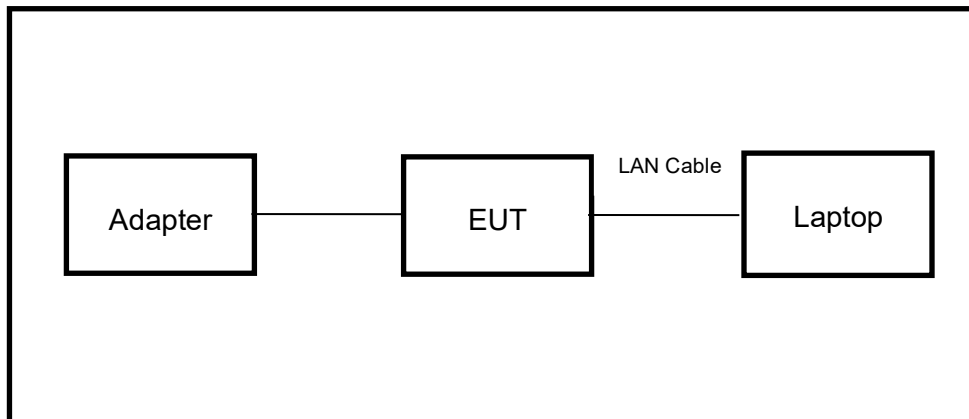



## 6. MEASURING INSTRUMENT AND SOFTWARE USED

Conducted Emissions (Instrument)							
Used	Equipment	Manufacturer	Model No.	Serial No.	Upper Last Cal.	Last Cal.	Next Cal.
<input checked="" type="checkbox"/>	EMI Test Receiver	R&S	ESR3	126700	2017-12-14	2018-12-13	2019-12-12
<input checked="" type="checkbox"/>	Two-Line V-Network	R&S	ENV216	126701	2017-12-14	2018-12-13	2019-12-12
<input checked="" type="checkbox"/>	Artificial Mains Networks	R&S	ENY81	126711	2017-12-14	2018-12-13	2019-12-12
Software							
Used	Description		Manufacturer	Name	Version		
<input checked="" type="checkbox"/>	Test Software for Conducted disturbance		R&S	EMC32	Ver. 9.25		
Radiated Emissions (Instrument)							
Used	Equipment	Manufacturer	Model No.	Serial No.	Upper Last Cal.	Last Cal.	Next Cal.
<input checked="" type="checkbox"/>	Spectrum Analyzer	Keysight	N9010B	MY57110128	2018-05-30	2019-05-29	2020-05-28
<input checked="" type="checkbox"/>	EMI test receiver	R&S	ESR26	1267603	2017-12-14	2018-12-13	2019-12-22
<input checked="" type="checkbox"/>	Receiver Antenna (9kHz-30MHz)	Schwarzbeck	FMZB 1513	513-265	2017-06-18	2018-06-17	2019-06-16
<input checked="" type="checkbox"/>	Receiver Antenna (30MHz-1GHz)	SunAR RF Motion	JB1	126704	N/A	2019-01-28	2022-01-27
<input checked="" type="checkbox"/>	Receiver Antenna (1GHz-18GHz)	R&S	HF907	126705	2018-01-27	2019-01-26	2020-01-26
<input checked="" type="checkbox"/>	Receiver Antenna (18GHz-26.5GHz)	Schwarzbeck	BBHA9170	126706	2018-02-07	2019-02-06	2020-02-05
<input checked="" type="checkbox"/>	Receiver Antenna (26.5GHz-40GHz)	TOYO	HAP 26-40W	00000012	2017-07-26	2018-07-25	2019-07-24
<input checked="" type="checkbox"/>	Pre-amplification (To 1GHz)	R&S	SCU-03D	134666	2018-02-07	2019-02-06	2020-02-05
<input checked="" type="checkbox"/>	Pre-amplification (To 18GHz)	TDK	PA-02-0118	TRS-305-00066	2017-12-12	2018-12-11	2019-12-10
<input checked="" type="checkbox"/>	Pre-amplification (To 26.5GHz)	R&S	SCU-26D	134668	2018-02-07	2019-02-06	2020-02-05
<input checked="" type="checkbox"/>	Band Reject Filter	Wainwright	WRCJV8-2350-2400-2483.5-2533.5-40SS	1	2018-05-30	2019-05-29	2020-05-28
<input checked="" type="checkbox"/>	Highpass Filter	Wainwright	WHKX10-2700-3000-18000-40SS	2	2018-05-30	2019-05-29	2020-05-28
Software							
Used	Description		Manufacturer	Name	Version		
<input checked="" type="checkbox"/>	Test Software for Radiated disturbance		Tonscend	JS32	V1.0		
Other instruments							
Used	Equipment	Manufacturer	Model No.	Serial No.	Upper Last Cal.	Last Cal.	Next Cal.
<input checked="" type="checkbox"/>	Spectrum Analyzer	Keysight	N9010B	MY57110128	2018-05-30	2019-05-29	2020-05-28
<input checked="" type="checkbox"/>	Power Meter	Keysight	U2021XA	MY57110002	2018-06-13	2019-06-12	2020-06-11



## 7. MEASUREMENT METHODS

No.	Test Item	KDB Name	Section
1	6dB Bandwidth	KDB 558074 D01 15.247 Meas Guidance v05r02	8.2
2	Peak Output Power	KDB 558074 D01 15.247 Meas Guidance v05r02	8.3.1.3/8.3.2.3
3	Power Spectral Density	KDB 558074 D01 15.247 Meas Guidance v05r02	8.4
4	Out-of-band emissions in non-restricted bands	KDB 558074 D01 15.247 Meas Guidance v05r02	8.5
5	Out-of-band emissions in restricted bands	KDB 558074 D01 15.247 Meas Guidance v05r02	8.6
6	Band-edge	KDB 558074 D01 15.247 Meas Guidance v05r02	8.7
7	Conducted Emission Test For AC Power Port	ANSI C63.10-2013	6.2



## 8. ANTENNA PORT TEST RESULTS

### 8.1. ON TIME AND DUTY CYCLE

#### LIMITS

None; for reporting purposes only

#### PROCEDURE

KDB 558074 Zero-Span Spectrum Analyzer Method

#### TEST SETUP

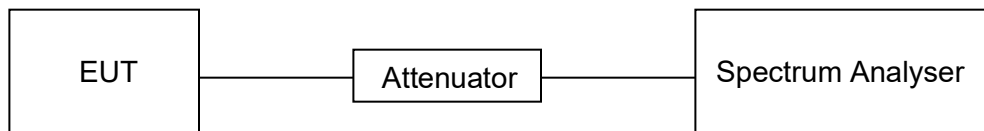

#### TEST ENVIRONMENT

Temperature	20°C	Relative Humidity	56%
Atmosphere Pressure	101kPa	Test Voltage	DC 12V

#### RESULTS

Mode	On Time (msec)	Period (msec)	Duty Cycle x (Linear)	Duty Cycle (%)	Duty Cycle Correction Factor (db)	1/T Minimum VBW (KHz)	Final setting For VBW (KHz)
11B	100.3	100.3	1	100%	0	0.01	0.01
11G	100.3	100.3	1	100%	0	0.01	0.01
11N20	100.3	100.3	1	100%	0	0.01	0.01
11N40	100.3	100.3	1	100%	0.	0.01	0.01

Note:

Duty Cycle Correction Factor=10log (1/x).

Where: x is Duty Cycle (Linear)

Where: T is On Time

If that calculated VBW is not available on the analyzer then the next higher value should be used.



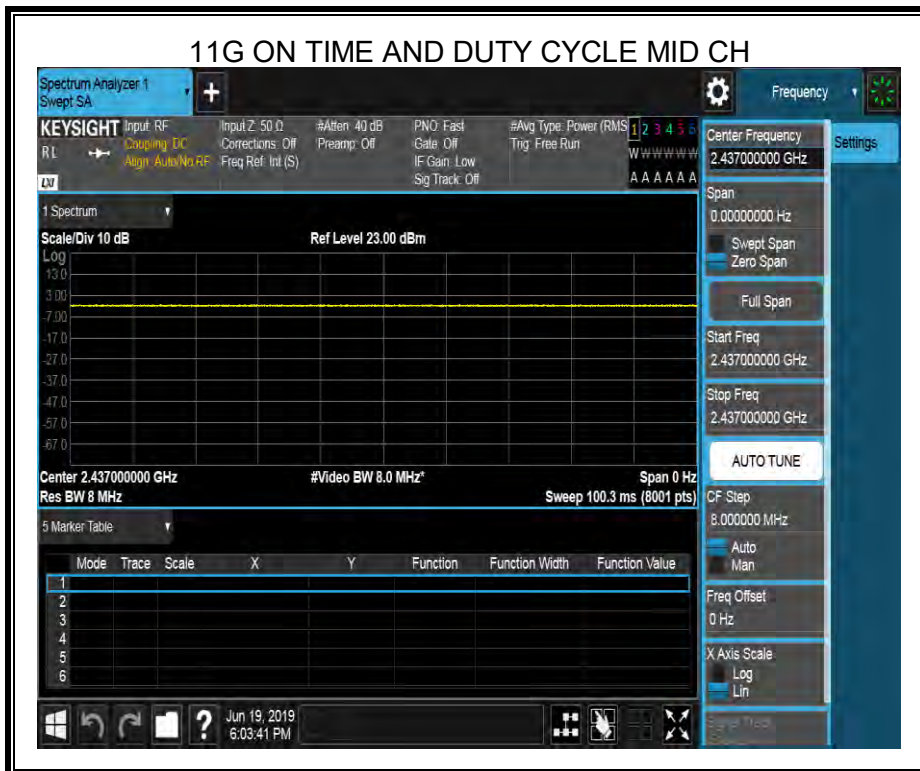
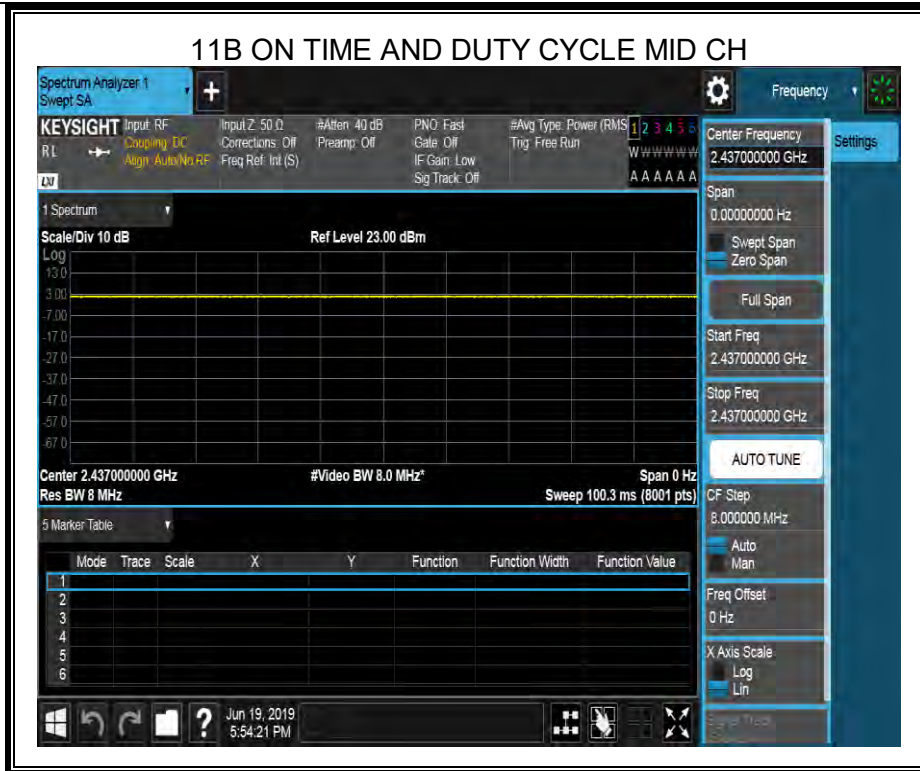

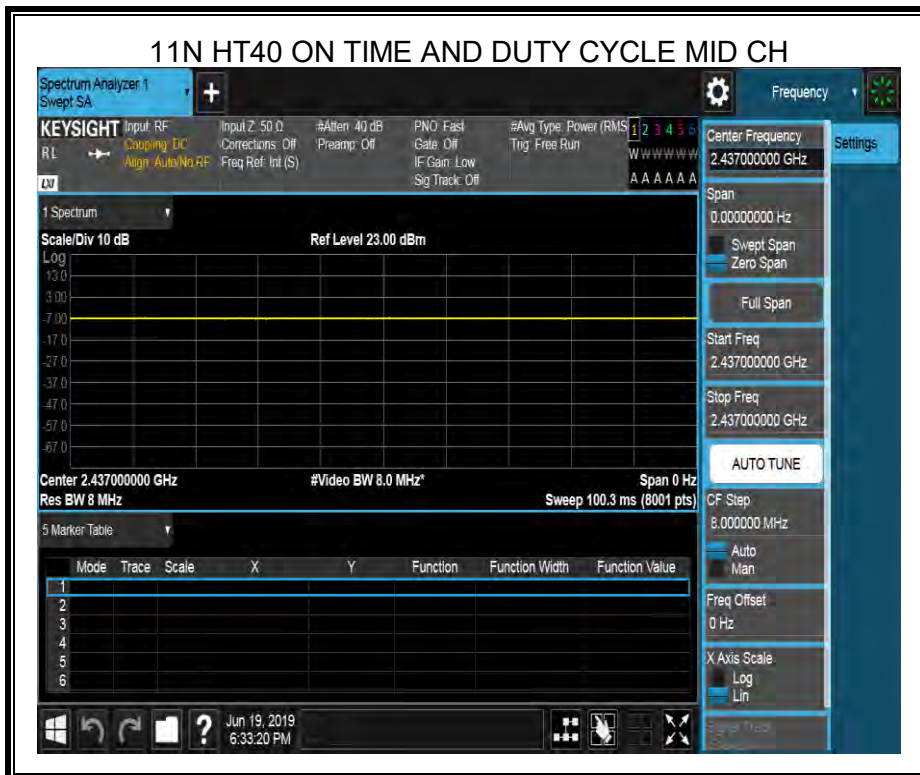
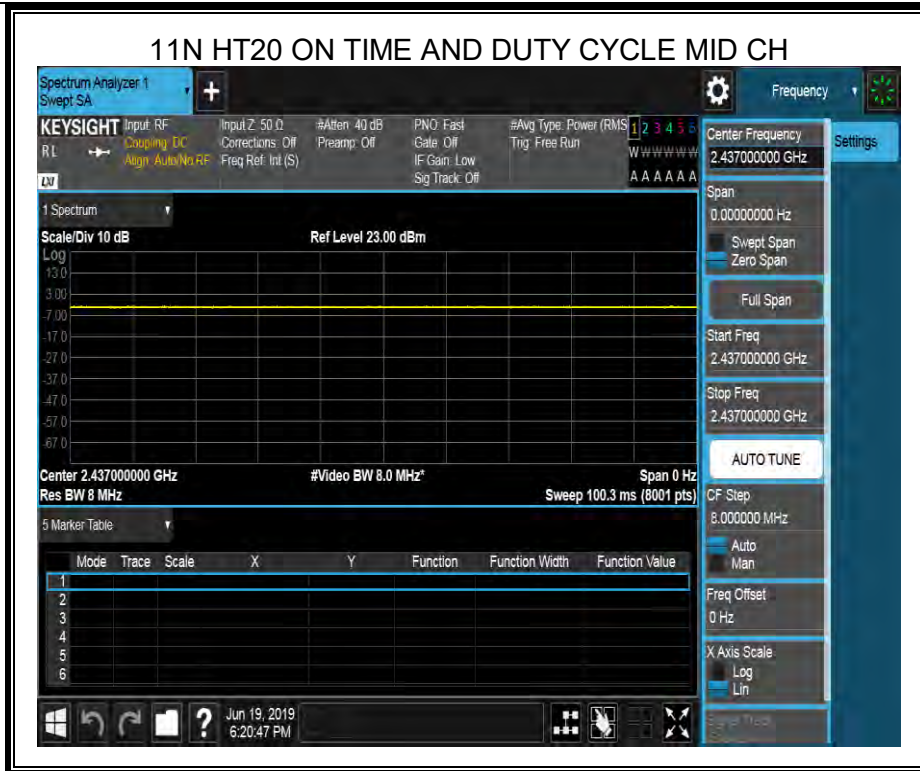

## 8.2. 6 dB DTS BANDWIDTH

### LIMITS

CFR 47 FCC Part15 (15.247) Subpart C			
Section	Test Item	Limit	Frequency Range (MHz)
CFR 47 FCC 15.247(a)(2)	6 dB Bandwidth	$\geq 500\text{KHz}$	2400-2483.5

### TEST PROCEDURE

Connect the UUT to the spectrum analyser and use the following settings:

Center Frequency	The centre frequency of the channel under test
Detector	Peak
RBW	100K
VBW	$\geq 3 \times \text{RBW}$
Trace	Max hold
Sweep	Auto couple

Allow the trace to stabilize and measure the maximum width of the emission that is constrained by the frequencies associated with the two outermost amplitude points (upper and lower frequencies) that are attenuated by 6 dB to the maximum level measured in the fundamental emission.

### TEST SETUP

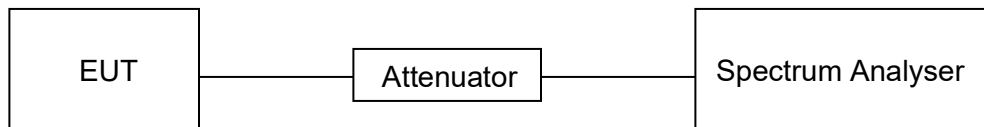



**TEST ENVIRONMENT**

Temperature	20°C	Relative Humidity	56%
Atmosphere Pressure	101kPa	Test Voltage	DC 12V

**RESULTS**

**8.2.1. 802.11b MODE**

Channel	6dB bandwidth (MHz)	Limit (kHz)	Result
Low	9.068	≥500	Pass
Middle	9.057	≥500	Pass
High	9.059	≥500	Pass





### 8.2.2. 802.11g MODE

Channel	6dB bandwidth (MHz)	Limit (kHz)	Result
Low	16.57	≥500	Pass
Middle	16.57	≥500	Pass
High	16.57	≥500	Pass

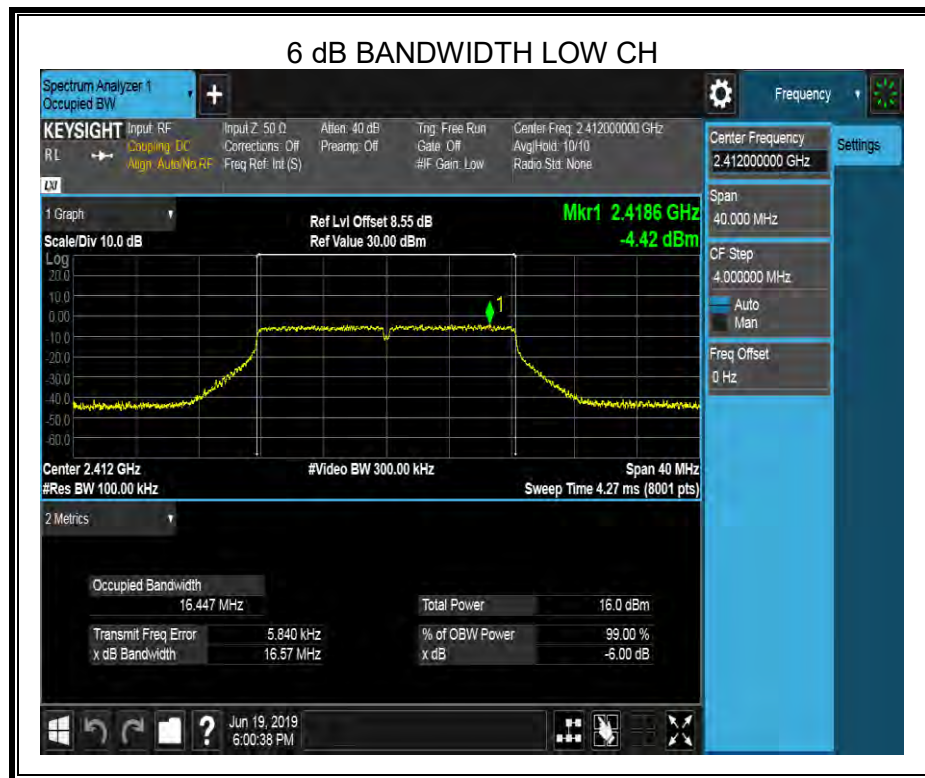

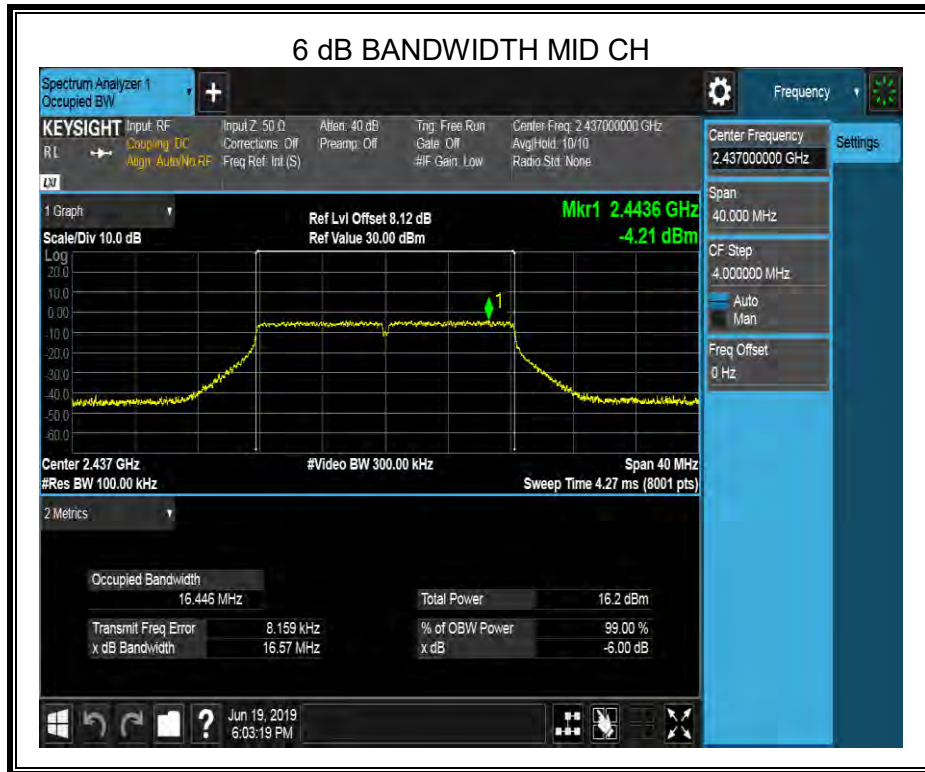



### 8.2.3. 802.11n HT20 MODE

Channel	6dB bandwidth (MHz)	Limit (kHz)	Result
Low	17.78	≥500	Pass
Middle	17.75	≥500	Pass
High	17.74	≥500	Pass





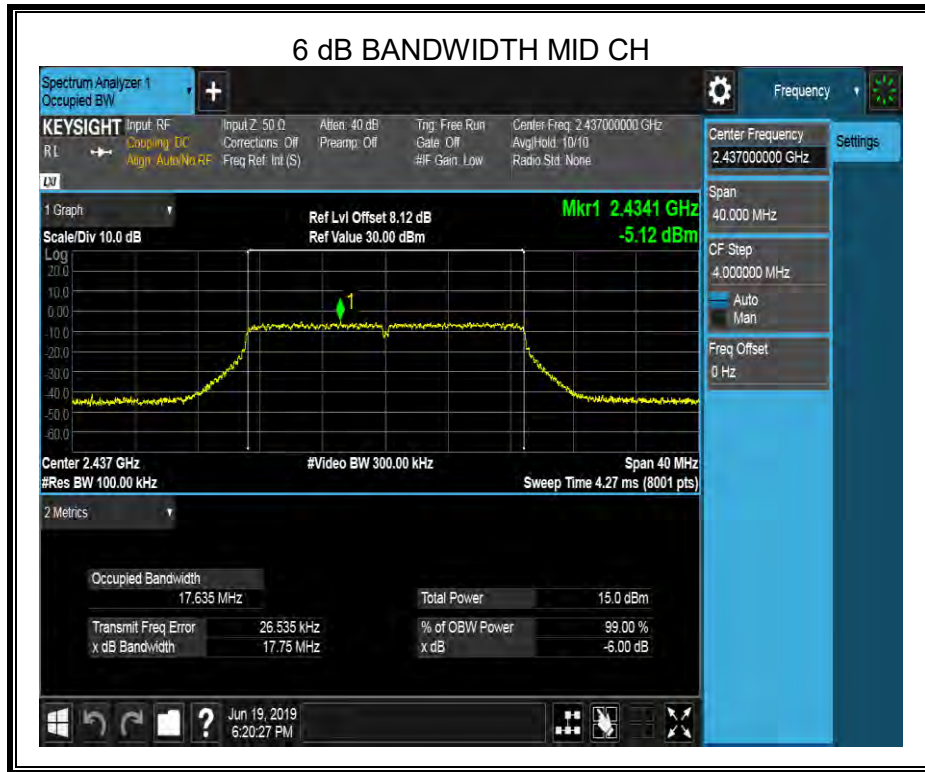



8.2.4. 802.11n HT40 MODE

Channel	6dB bandwidth (MHz)	Limit (kHz)	Result
Low	36.44	≥500	Pass
Middle	36.44	≥500	Pass
High	36.49	≥500	Pass

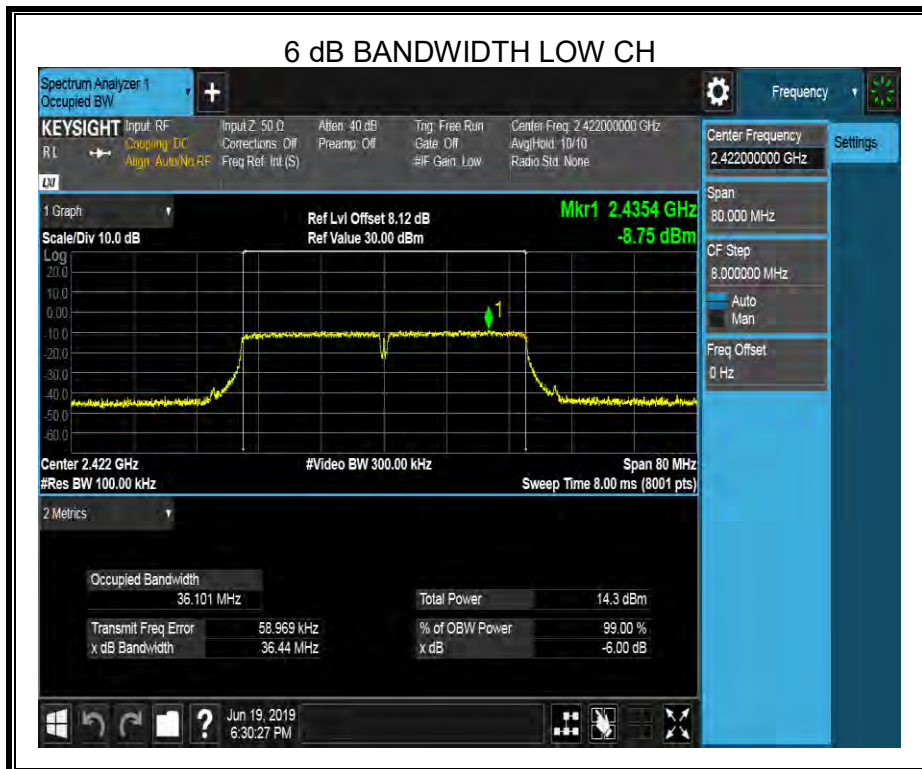

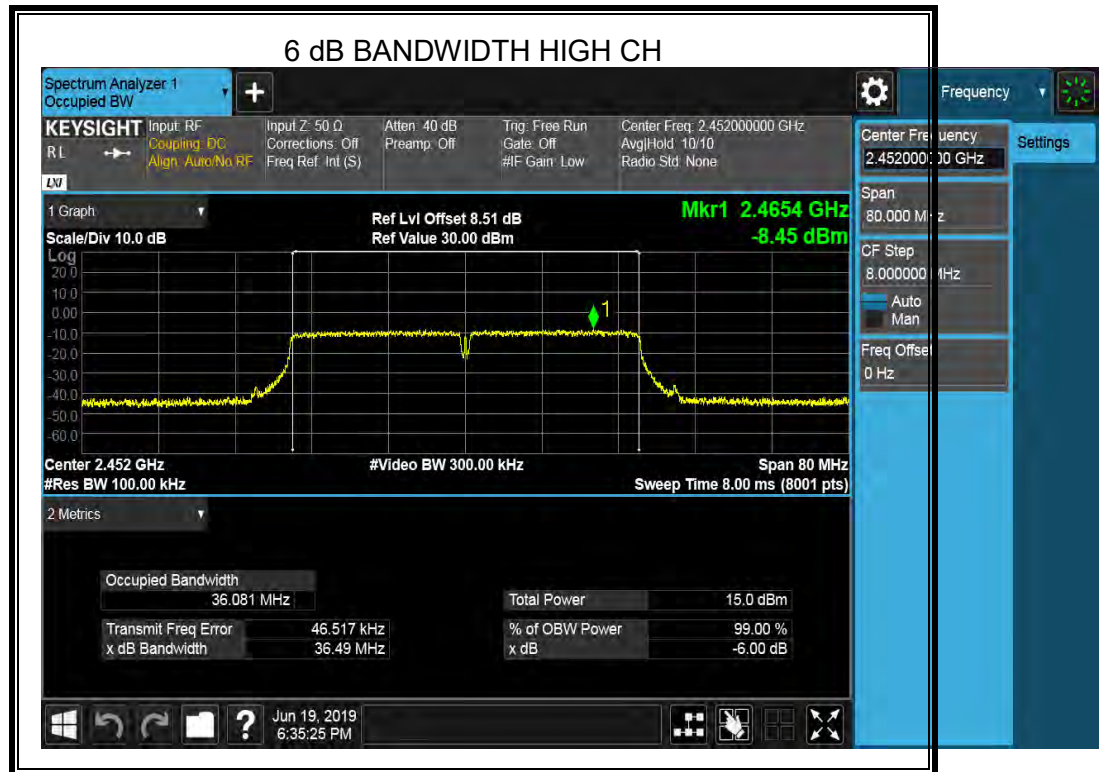



### 8.3. PEAK CONDUCTED OUTPUT POWER

#### LIMITS

CFR 47 FCC Part15 (15.247) Subpart C			
Section	Test Item	Limit	Frequency Range (MHz)
CFR 47 FCC 15.247(b)(3)	Peak Output Power	1 watt or 30dBm (See note1)	2400-2483.5
<b>Note:</b> 1. If transmitting antennas of directional gain greater than 6 dBi are used, both the maximum conducted output power and the maximum power spectral density shall be reduced by the amount in dB that the directional gain of the antenna exceeds 6dBi.			

#### TEST PROCEDURE

Place the EUT on the table and set it in the transmitting mode.  
 Remove the antenna from the EUT and then connect a low loss RF cable from the antenna port to the Power sensor.  
 Measure the power of each channel.  
 Peak Detector use for Peak result.  
 AVG Detector use for AVG result.

#### TEST SETUP

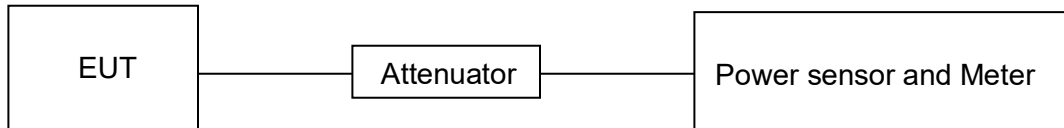

#### TEST ENVIRONMENT

Temperature	20°C	Relative Humidity	56%
Atmosphere Pressure	101kPa	Test Voltage	DC 12V



**RESULTS**

**8.3.1. 802.11b MODE**

Test Channel	ANT.	Maximum Conducted Output Power(PK) (dBm)	LIMIT
			dBm
Low	1	14.01	30
Middle	1	13.81	30
High	1	14.03	30

**8.3.2. 802.11g MODE**

Test Channel	ANT.	Maximum Conducted Output Power(PK) (dBm)	LIMIT
			dBm
Low	1	17.50	30
Middle	1	17.72	30
High	1	18.04	30

**8.3.3. 802.11n HT20 MODE**

Test Channel	ANT.	Maximum Conducted Output Power(PK) (dBm)	LIMIT
			dBm
Low	1	16.51	30
Middle	1	16.77	30
High	1	17.14	30

**8.3.4. 802.11n HT40 MODE**

Test Channel	ANT.	Maximum Conducted Output Power(PK) (dBm)	LIMIT
			dBm
Low	1	16.07	30
Middle	1	16.45	30
High	1	16.70	30



## 8.4. POWER SPECTRAL DENSITY

### LIMITS

CFR 47 FCC Part15 (15.247) Subpart C			
Section	Test Item	Limit	Frequency Range (MHz)
CFR 47 FCC §15.247 (e)	Power Spectral Density	8 dBm/3 kHz (See note1)	2400-2483.5
<b>Note:</b> 1. If transmitting antennas of directional gain greater than 6 dBi are used, both the maximum conducted output power and the maximum power spectral density shall be reduced by the amount in dB that the directional gain of the antenna exceeds 6dBi.			

### TEST PROCEDURE

Connect the UUT to the spectrum analyser and use the following settings:

Center Frequency	The centre frequency of the channel under test
Detector	Peak
RBW	$3 \text{ kHz} \leq \text{RBW} \leq 100 \text{ kHz}$
VBW	$\geq 3 \times \text{RBW}$
Span	1.5 x DTS bandwidth
Trace	Max hold
Sweep time	Auto couple.

Allow trace to fully stabilize and use the peak marker function to determine the maximum amplitude level within the RBW.

If measured value exceeds limit, reduce RBW (no less than 3 kHz) and repeat.

### TEST SETUP

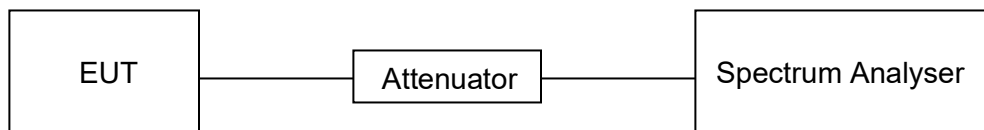

### TEST ENVIRONMENT

Temperature	20°C	Relative Humidity	56%
Atmosphere Pressure	101kPa	Test Voltage	DC 12V

**RESULTS**

**8.4.1. 802.11b MODE**

Test Channel	Power Spectral Density (dBm/100kHz)	Limit (dBm/3kHz)	Result
Low	1.84	8	PASS
Middle	1.63	8	PASS
High	1.83	8	PASS



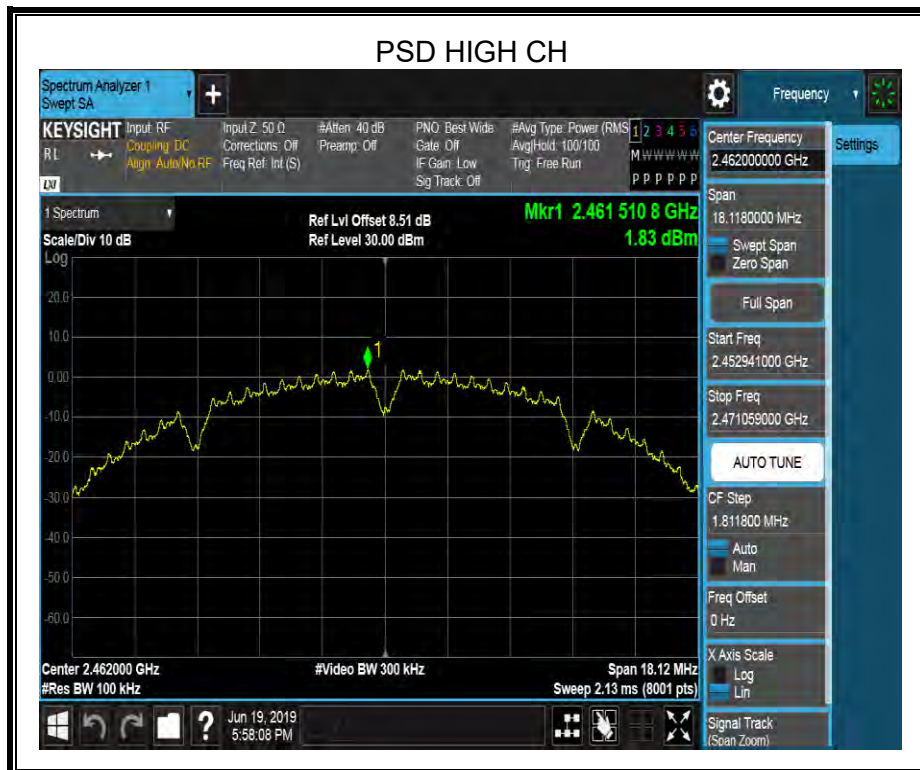
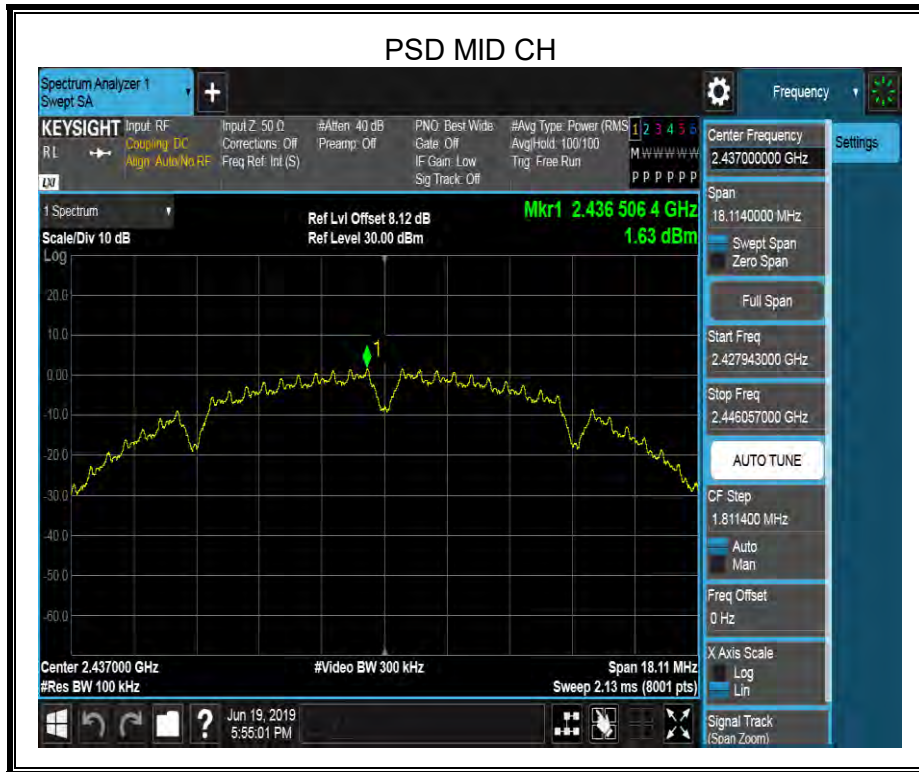



### 8.4.2. 802.11g MODE

Test Channel	Power Spectral Density (dBm/100kHz)	Limit (dBm/3kHz)	Result
Low	-4.64	8	PASS
Middle	-4.36	8	PASS
High	-3.98	8	PASS

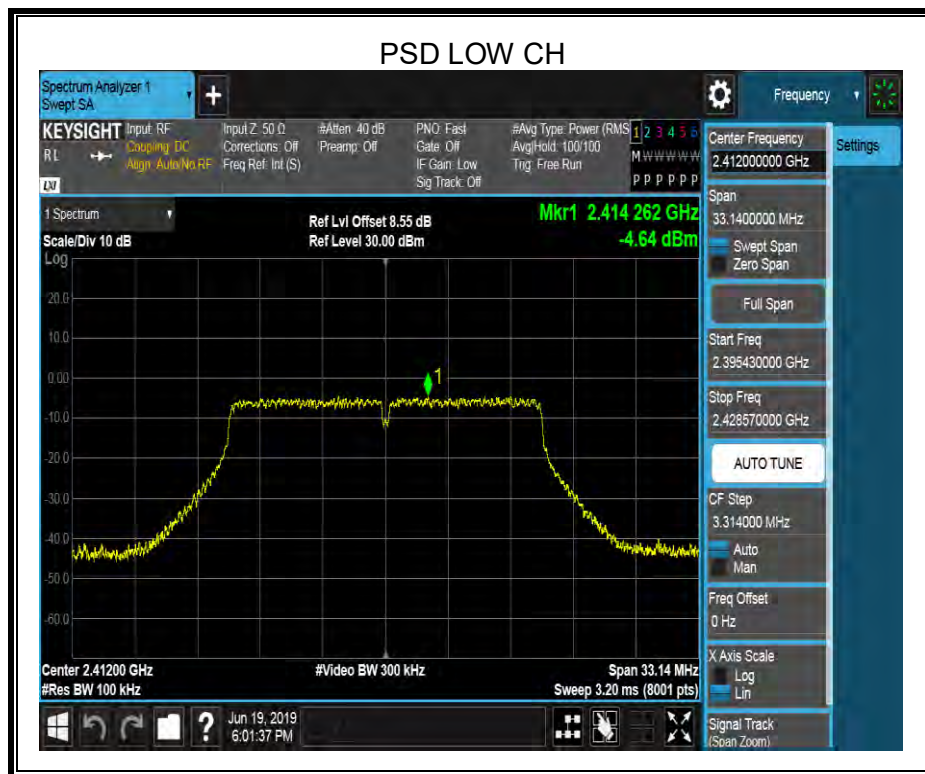

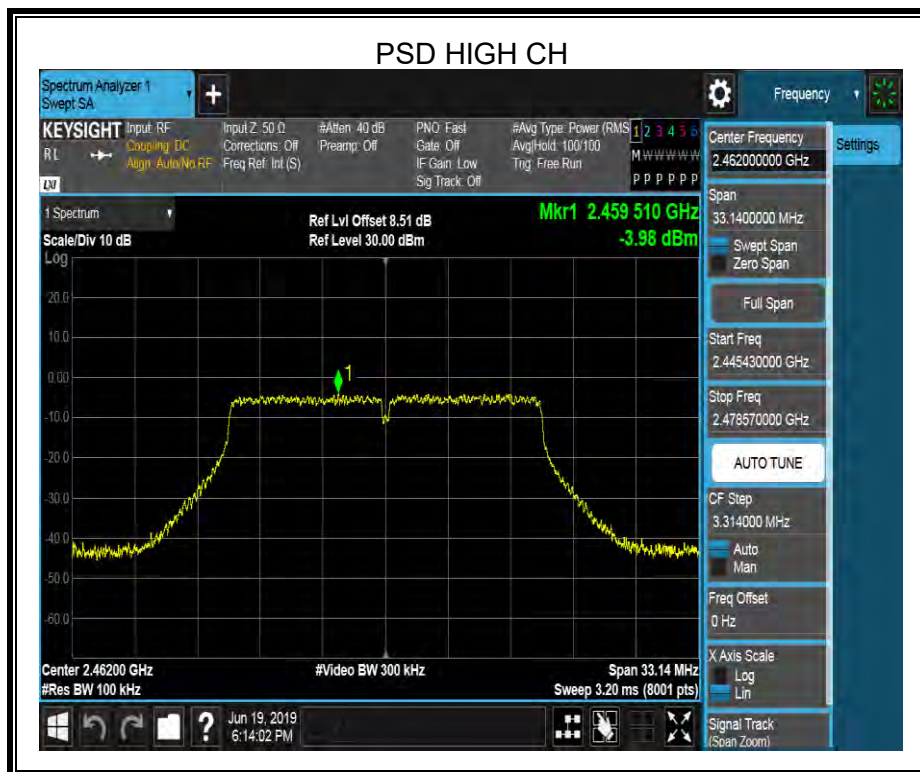
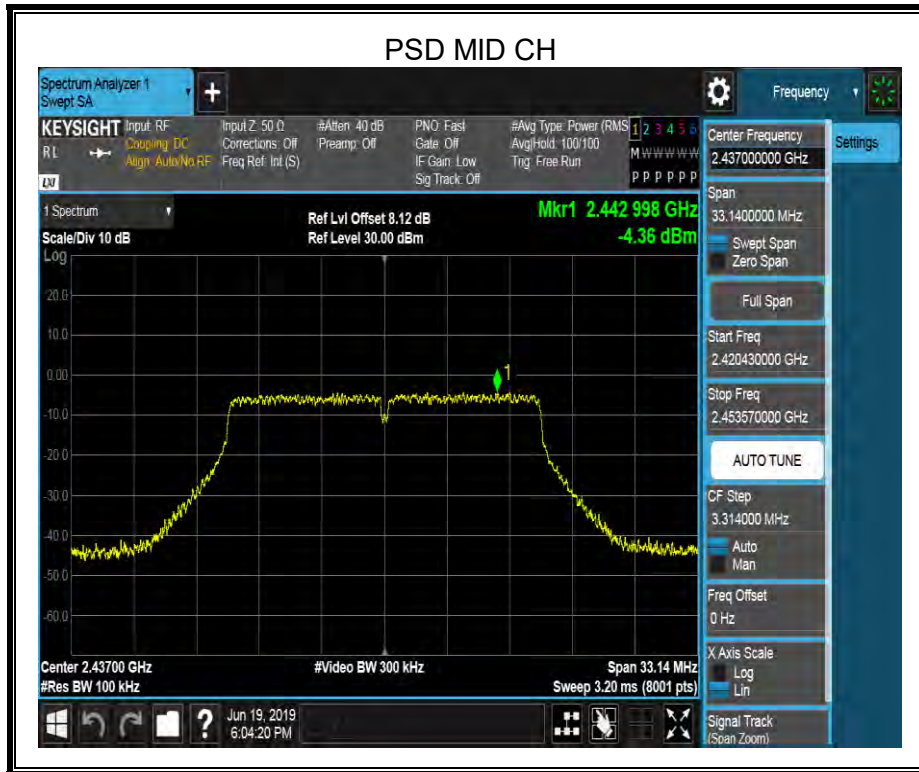

### 8.4.3. 802.11n HT20 MODE

Test Channel	Power Spectral Density (dBm/100kHz)	Limit (dBm/3kHz)	Result
Low	-5.32	8	PASS
Middle	-5.31	8	PASS
High	-4.94	8	PASS

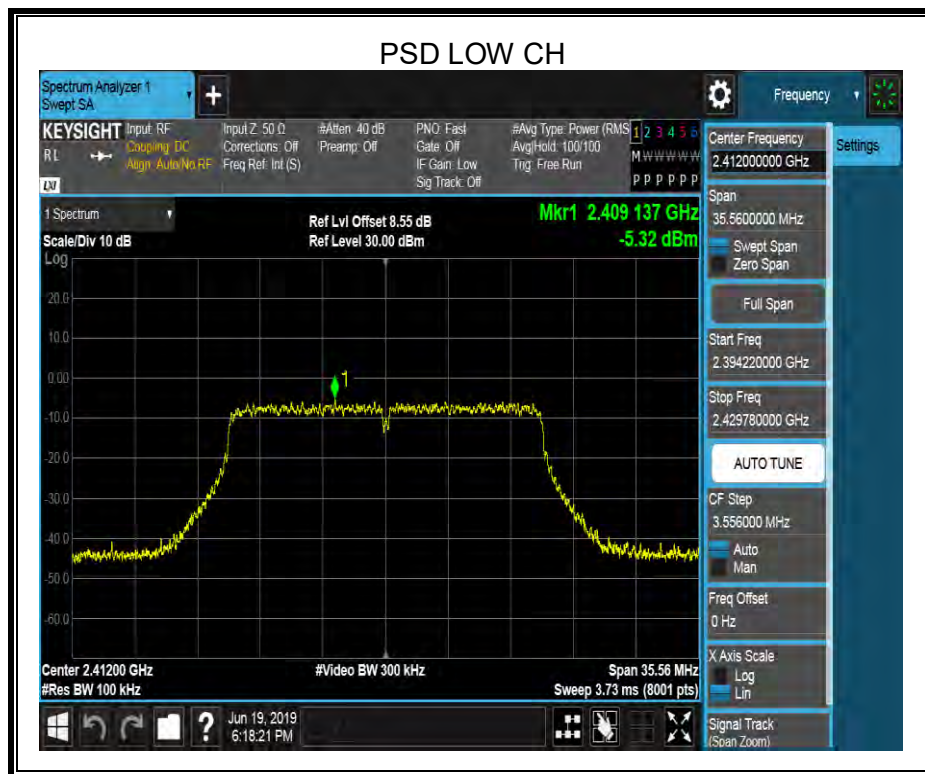

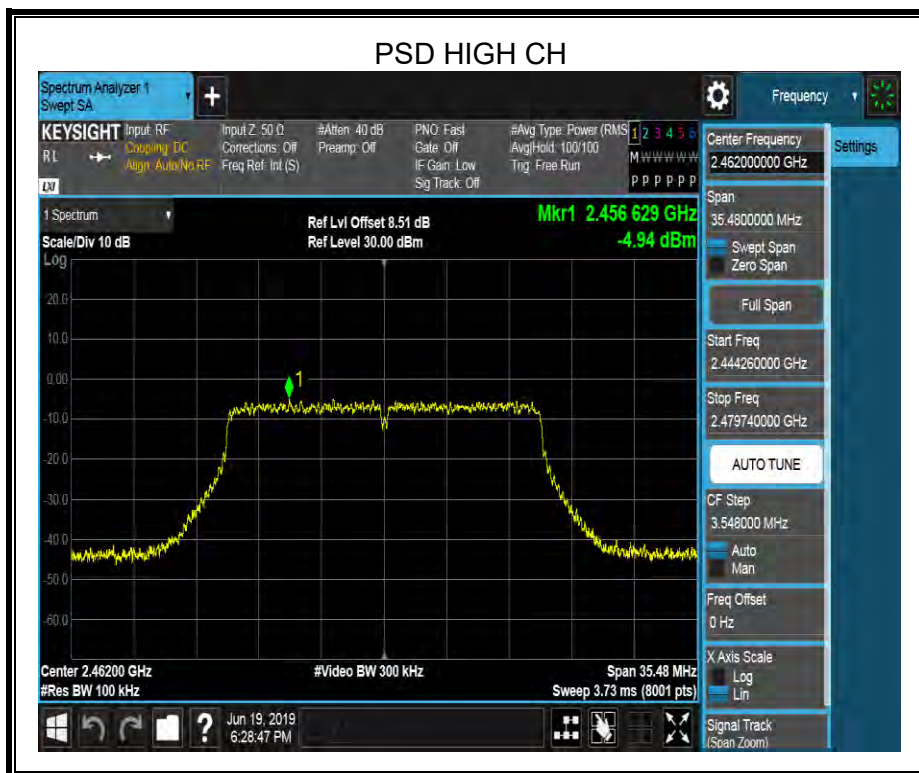
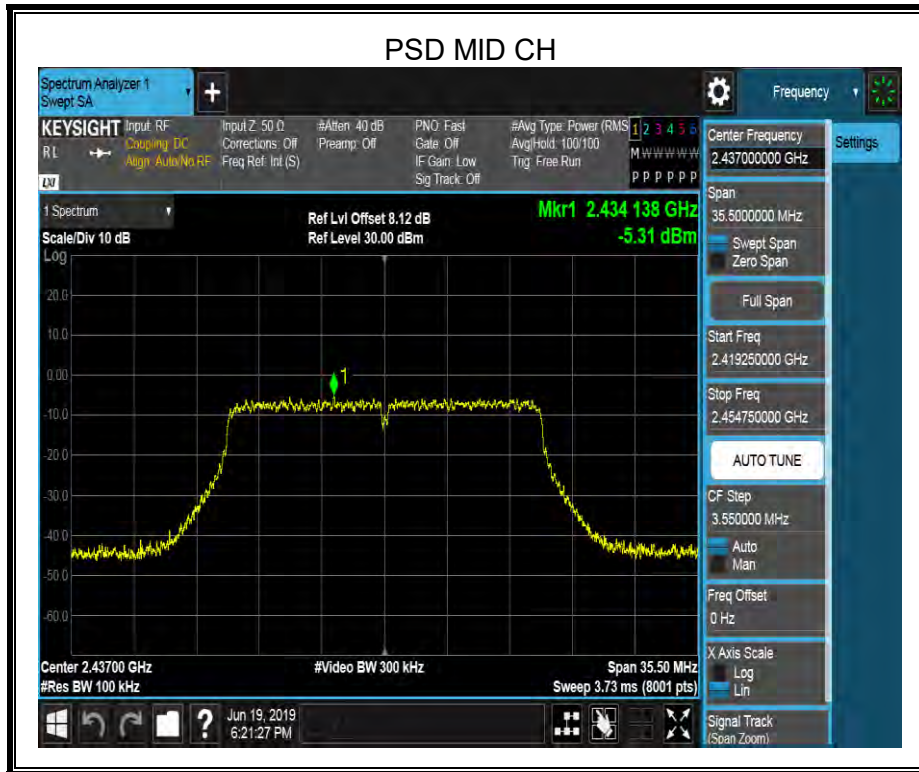

### 8.4.1. 802.11n HT40 MODE

Test Channel	Power Spectral Density (dBm/100kHz)	Limit (dBm/3kHz)	Result
Low	-8.93	8	PASS
Middle	-8.54	8	PASS
High	-8.54	8	PASS

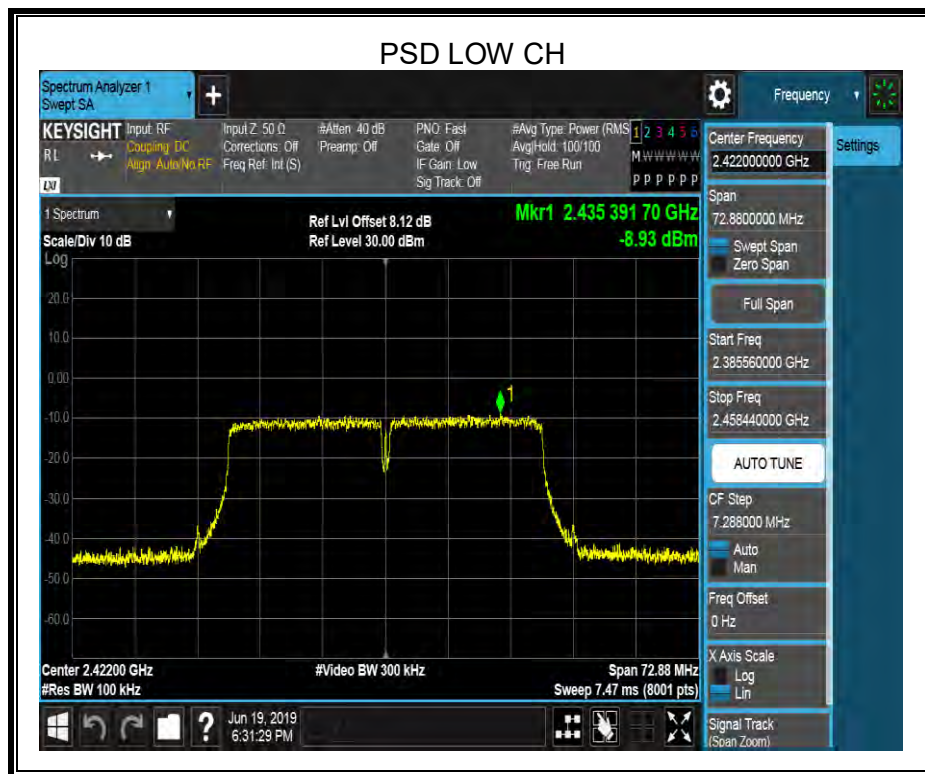

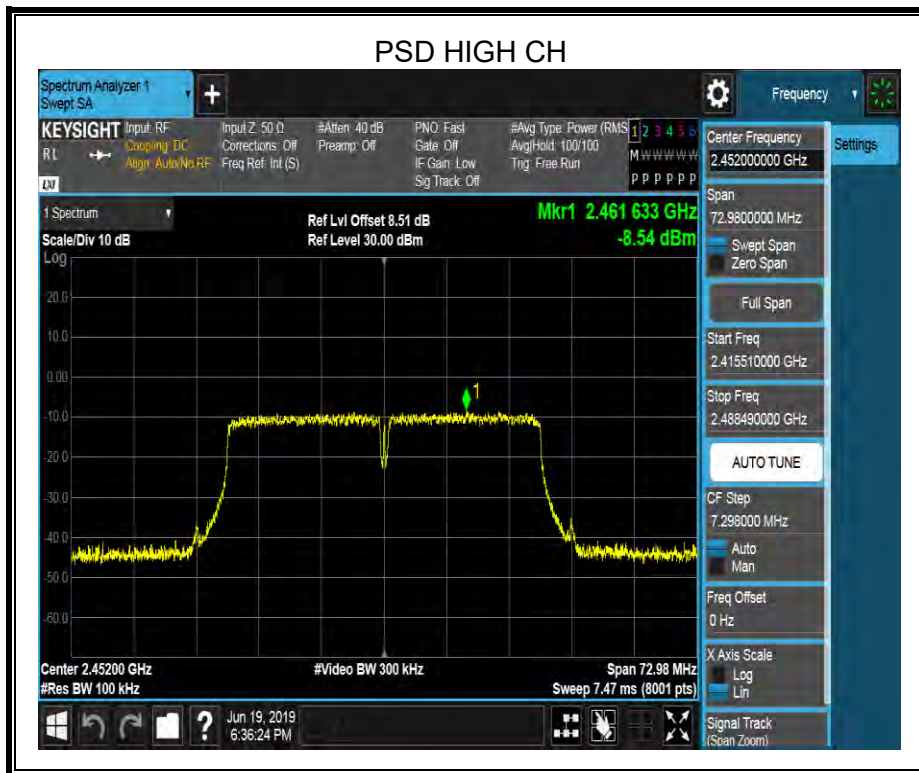
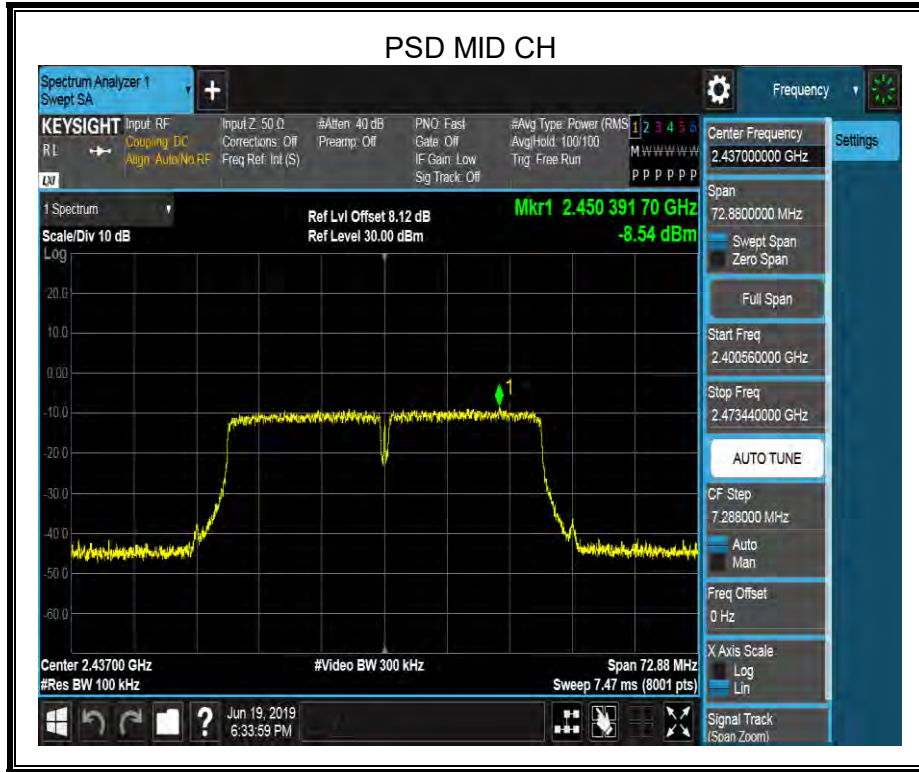



## 8.5. CONDUCTED BANDEGE AND SPURIOUS EMISSIONS

### LIMITS

CFR 47 FCC Part15 (15.247) Subpart C		
Section	Test Item	Limit
CFR 47 FCC §15.247 (d)	Conducted Bandedge and Spurious Emissions	at least 20 dB below that in the 100 kHz bandwidth within the band that contains the highest level of the desired power

### TEST PROCEDURE

Connect the UUT to the spectrum analyser and use the following settings:

Center Frequency	The centre frequency of the channel under test
Detector	Peak
RBW	100K
VBW	$\geq 3 \times \text{RBW}$
Span	1.5 x DTS bandwidth
Trace	Max hold
Sweep time	Auto couple.

Use the peak marker function to determine the maximum PSD level.

Span	Set the center frequency and span to encompass frequency range to be measured
Detector	Peak
RBW	100K
VBW	$\geq 3 \times \text{RBW}$
measurement points	$\geq \text{span}/\text{RBW}$
Trace	Max hold
Sweep time	Auto couple.

Use the peak marker function to determine the maximum amplitude level.



**TEST SETUP**

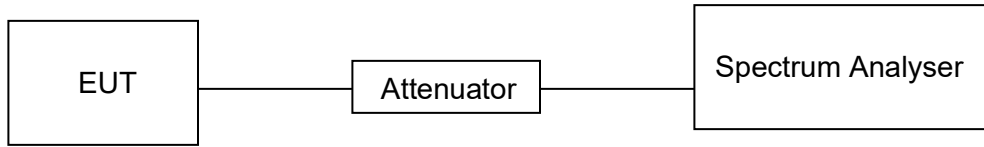

**TEST ENVIRONMENT**

Temperature	20°C	Relative Humidity	56%
Atmosphere Pressure	101kPa	Test Voltage	DC 12V





## RESULTS

### 8.5.1. 802.11b MODE

#### LOW CH BANDEDGE



#### LOW CH SPURIOUS EMISSIONS 30M-26G



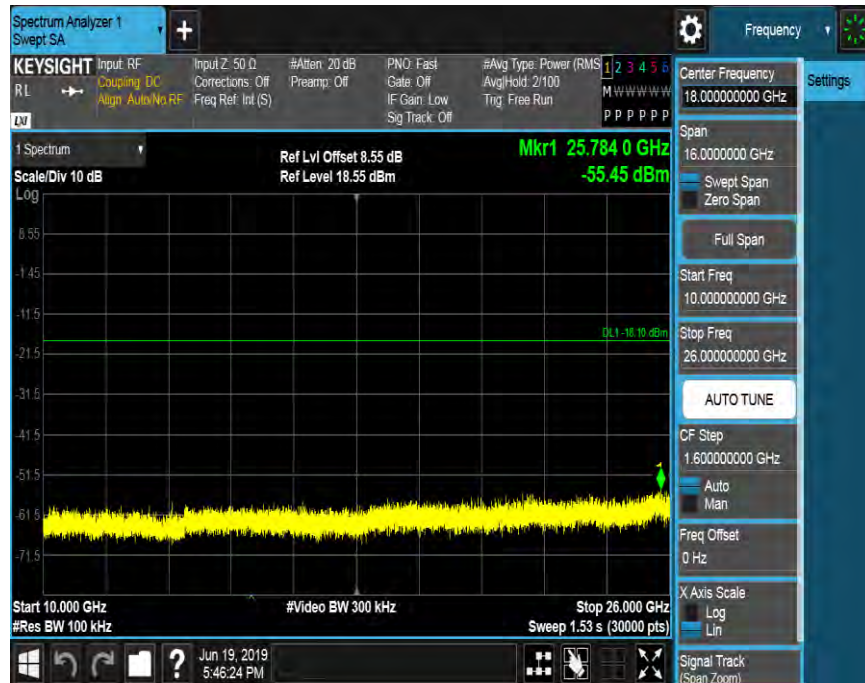
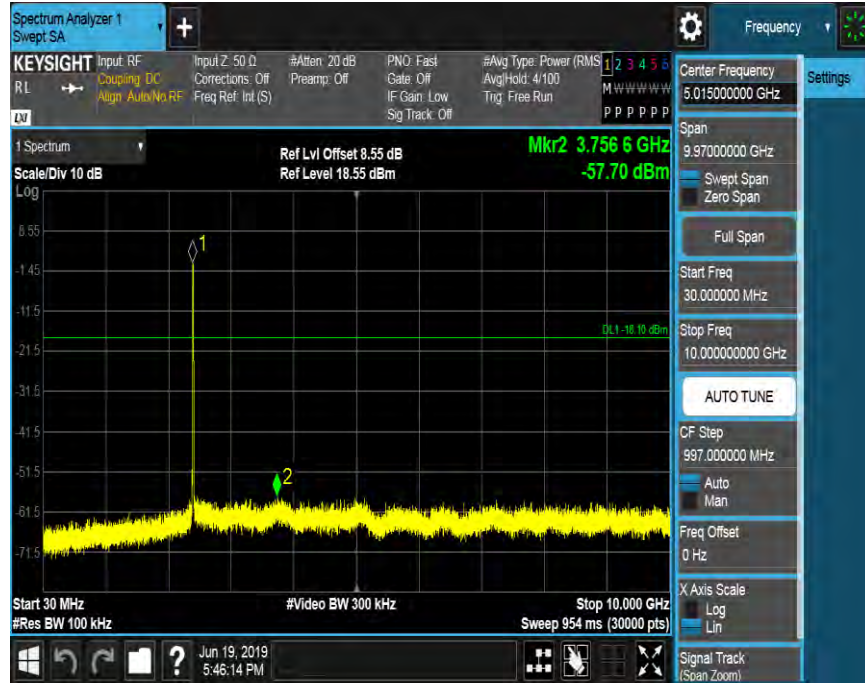



### MID CH SPURIOUS EMISSIONS 30M-26G





### HIGH CH BANDEDGE





### HIGH CH SPURIOUS EMISSIONS 30M-26G







### 8.5.2. 802.11g MODE

LOW CH BANDEDGE



LOW CH SPURIOUS EMISSIONS 30M-26G

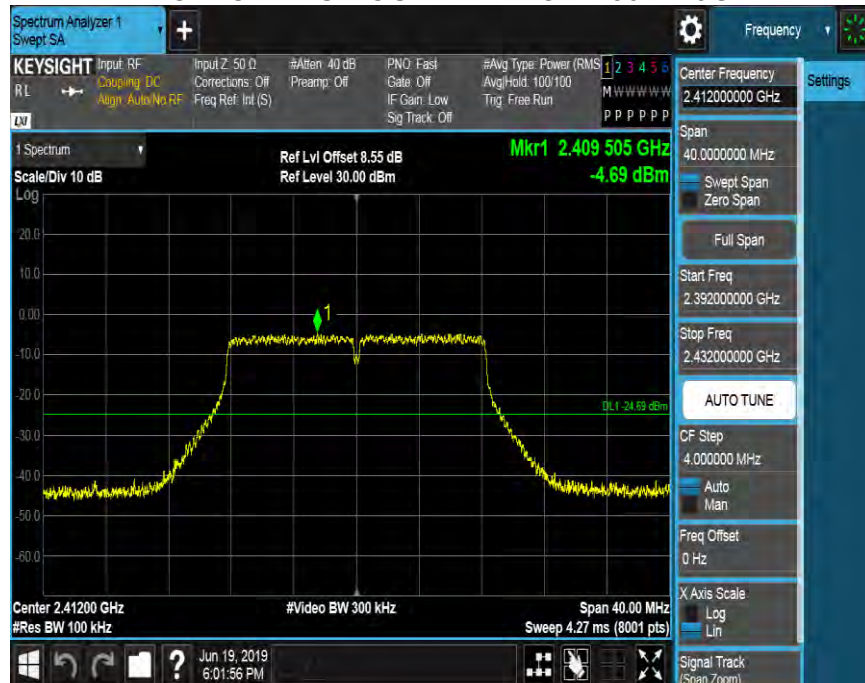

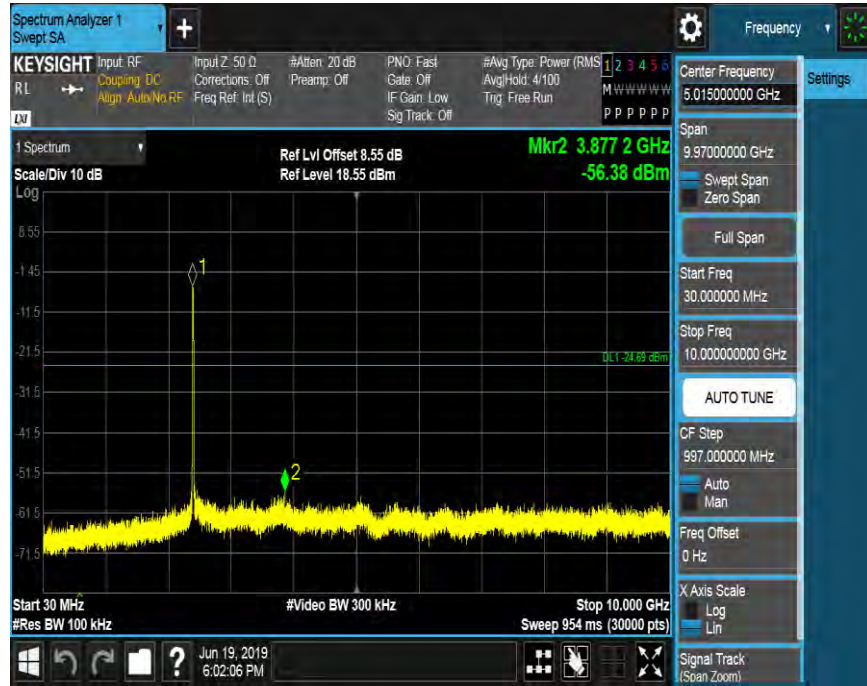





### MID CH SPURIOUS EMISSIONS 30M-26G

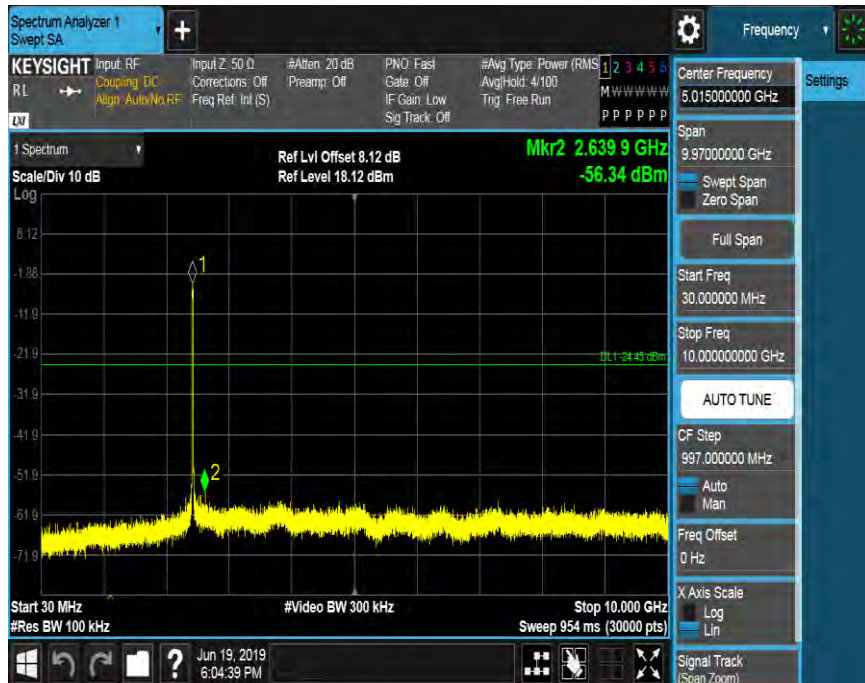
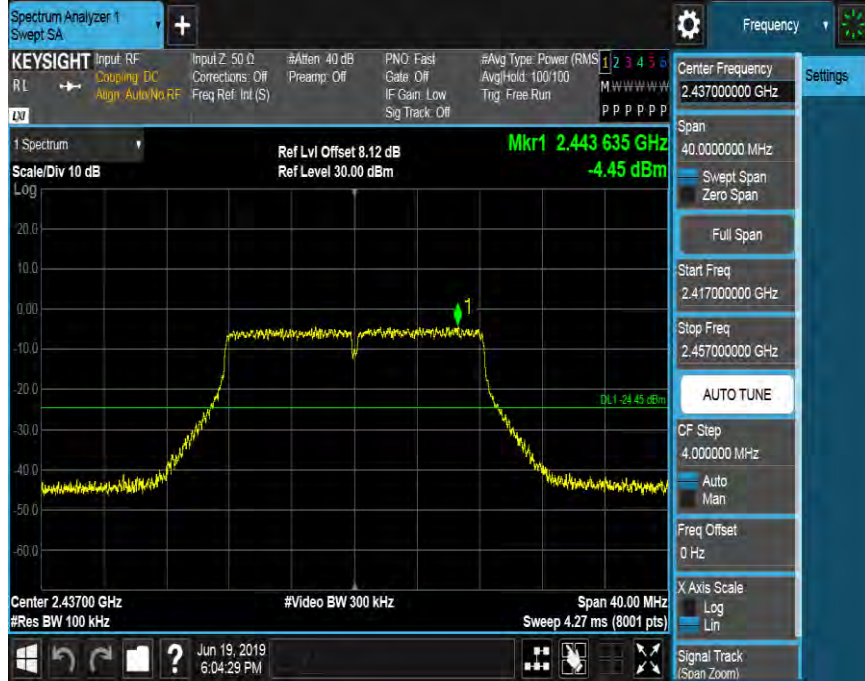

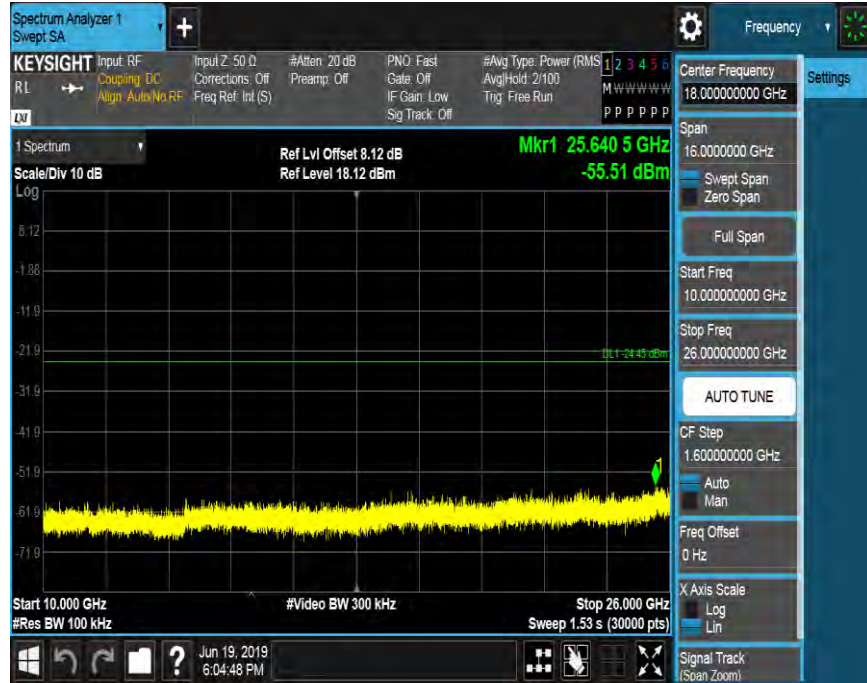

### HIGH CH BANDEDGE





### HIGH CH SPURIOUS EMISSIONS 30M-26G



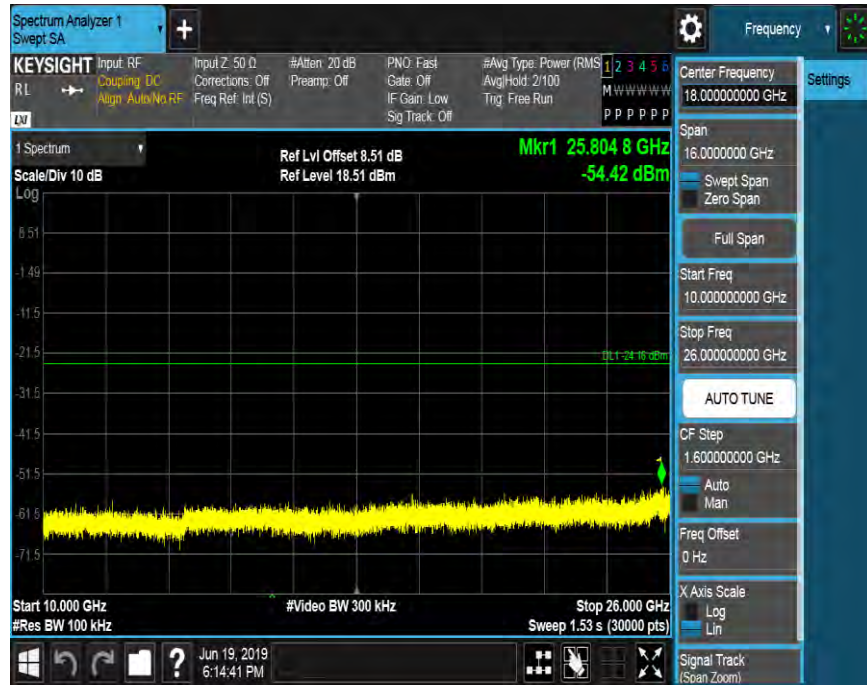

### 8.5.1. 802.11n HT20 MODE

#### LOW CH BANDEDGE

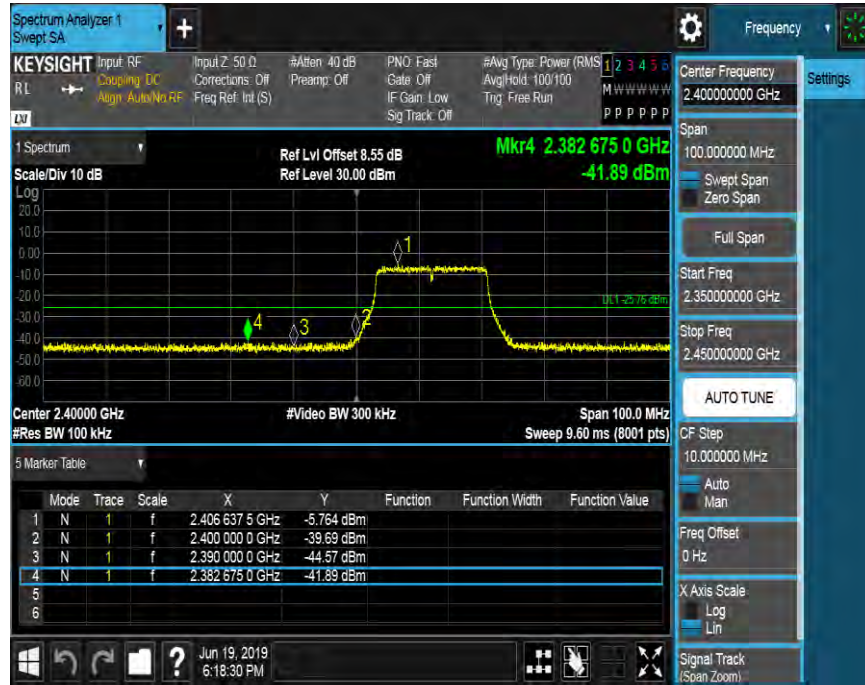

#### LOW CH SPURIOUS EMISSIONS 30M-26G



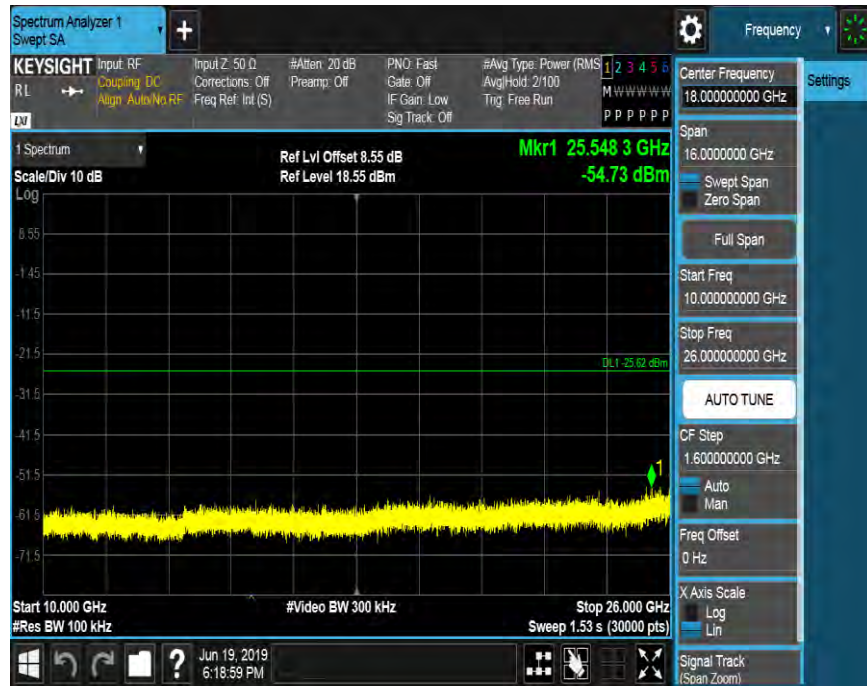
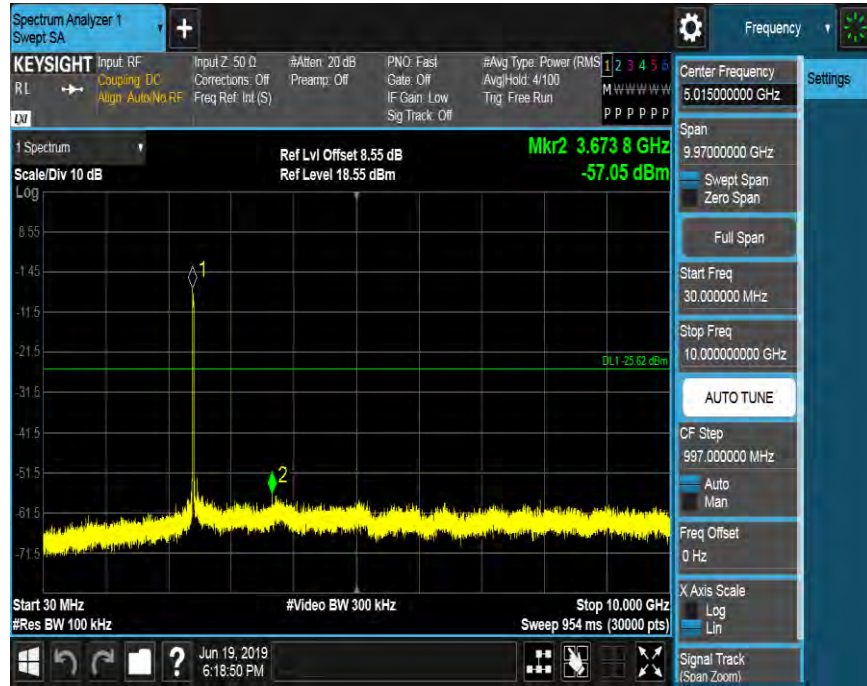



### MID CH SPURIOUS EMISSIONS 30M-26G





### HIGH CH BANDEDGE







### HIGH CH SPURIOUS EMISSIONS 30M-26G

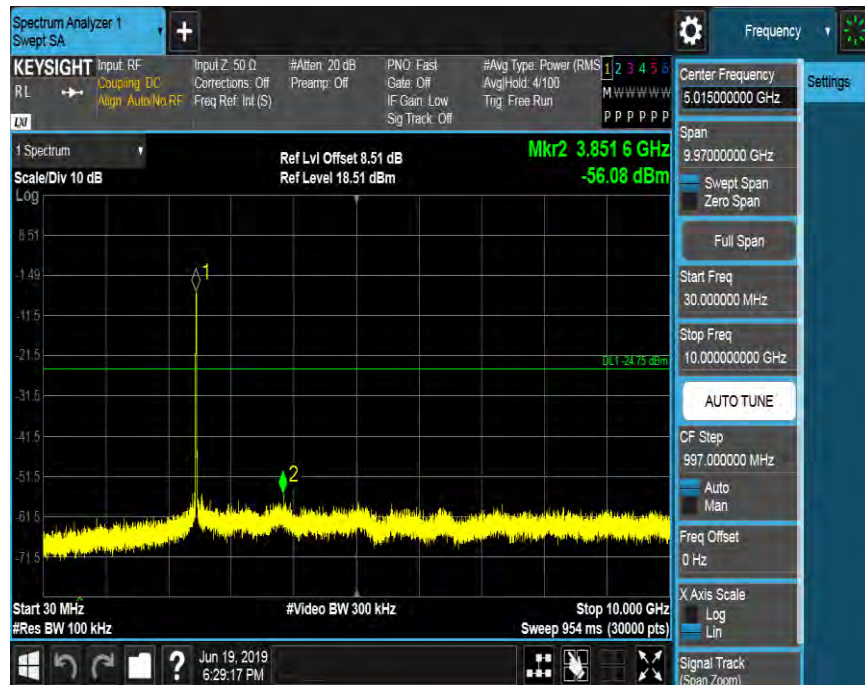



### 8.5.1. 802.11n HT40 MODE

#### LOW CH BANDEDGE

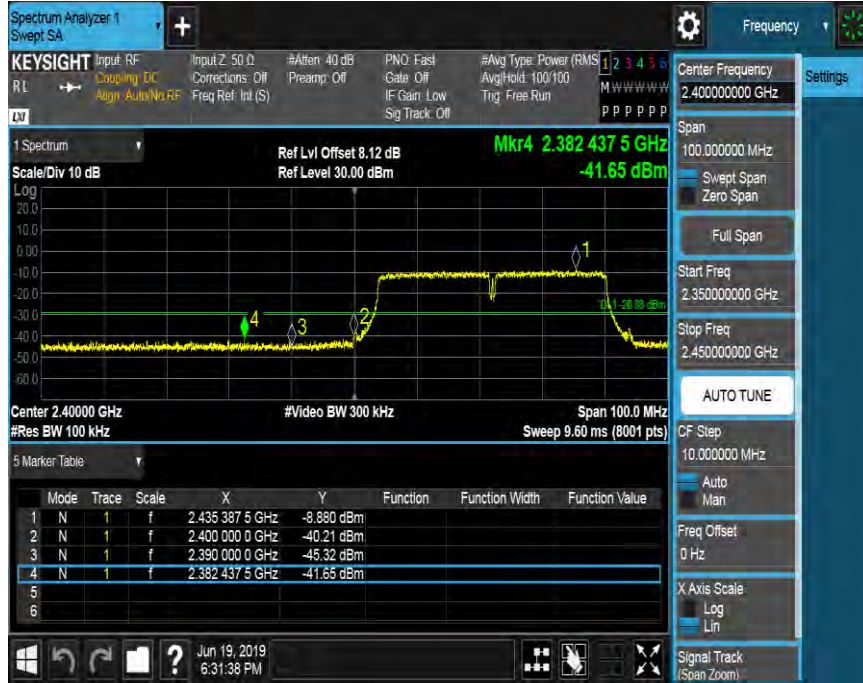

#### LOW CH SPURIOUS EMISSIONS 30M-26G



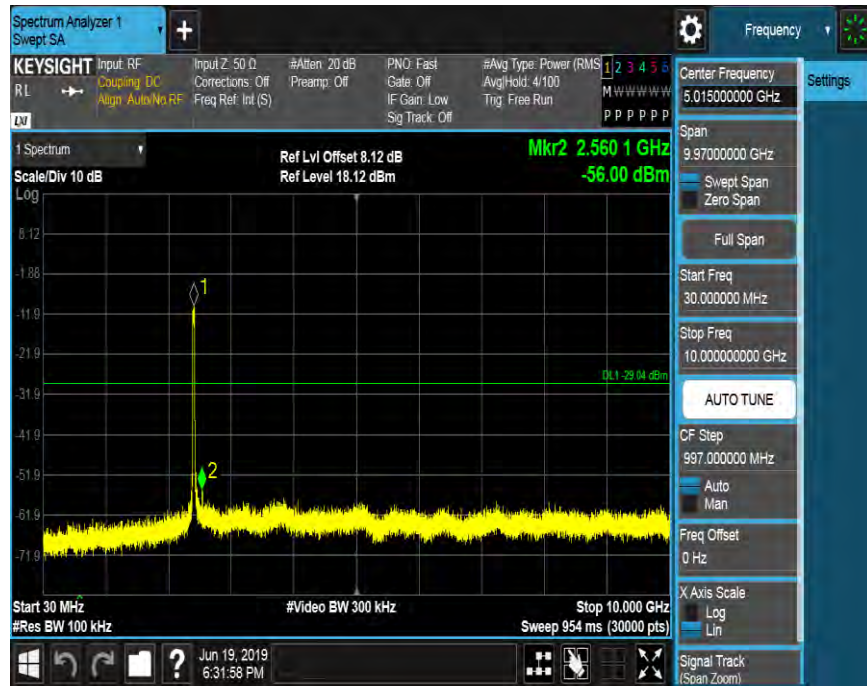



### MID CH SPURIOUS EMISSIONS 30M-26G

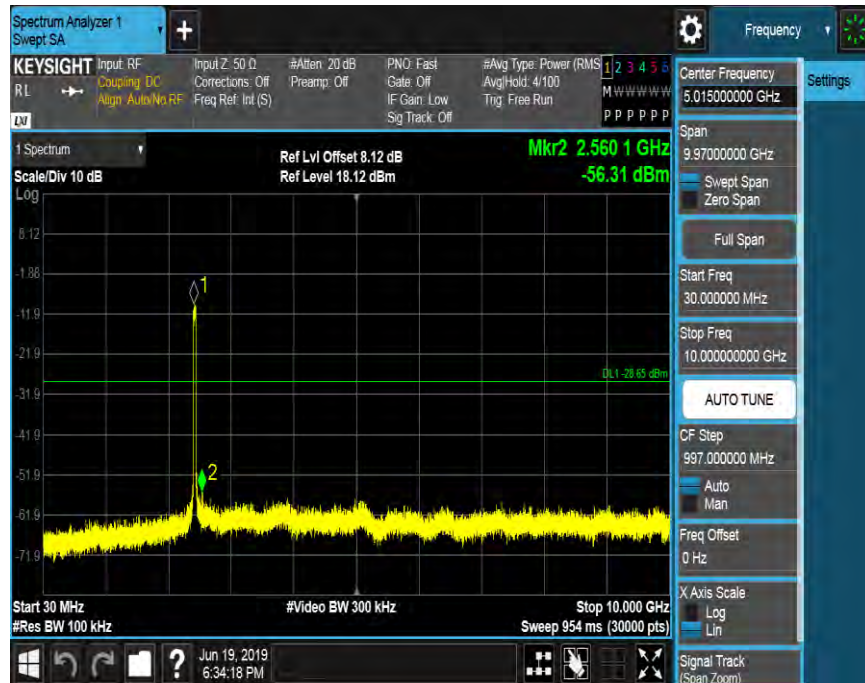

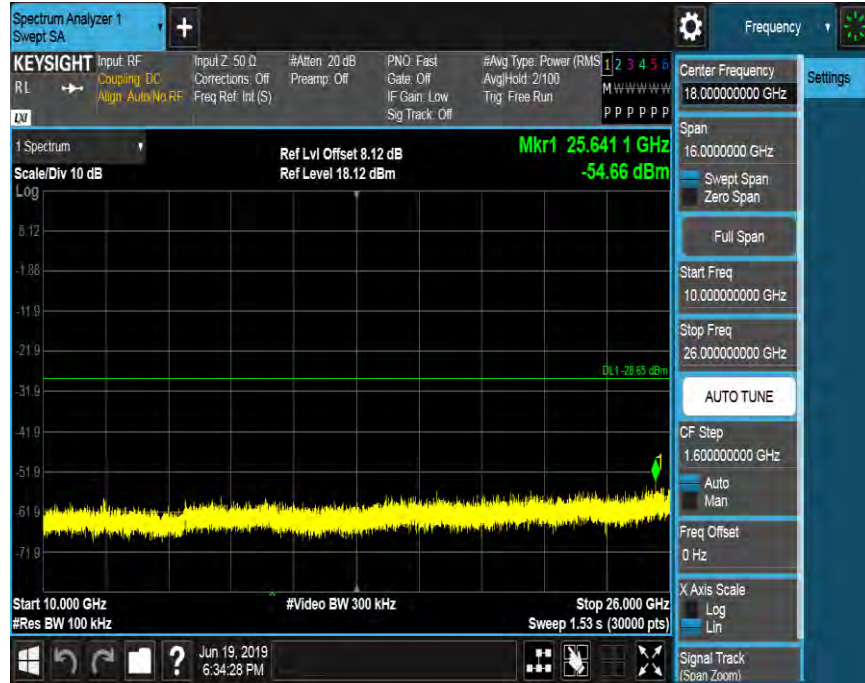

### HIGH CH BANDEDGE





### HIGH CH SPURIOUS EMISSIONS 30M-26G

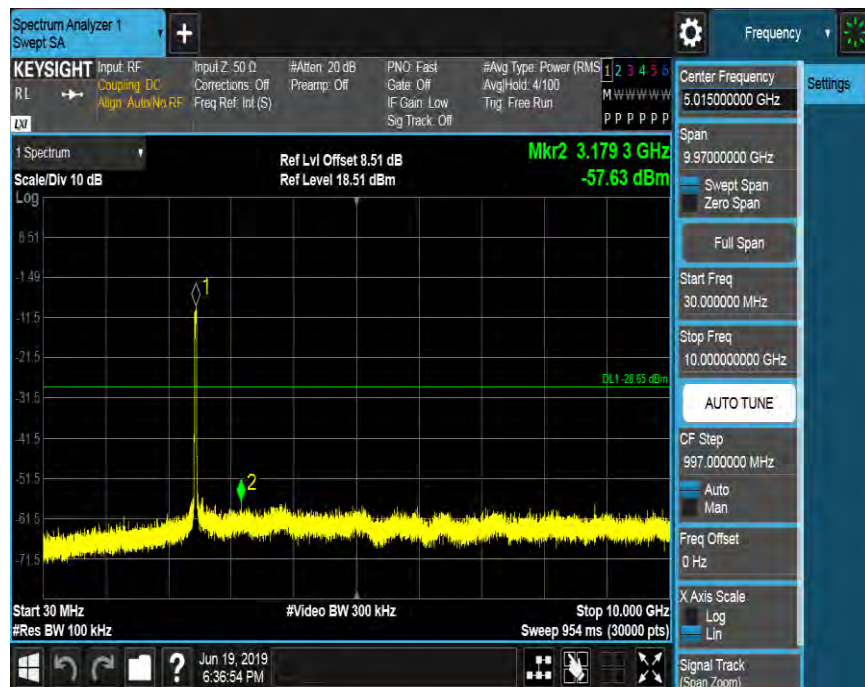

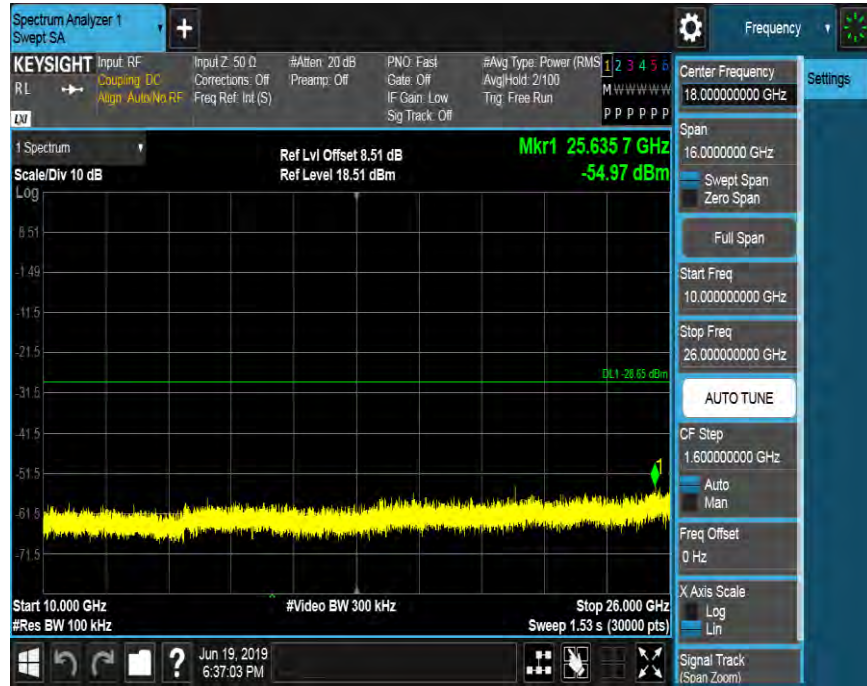





## 9. RADIATED TEST RESULTS

### LIMITS

Please refer to CFR 47 FCC §15.205 and §15.209

Radiation Disturbance Test Limit for FCC (Class B)(9KHz-1GHz)

Frequency (MHz)	Field Strength (microvolts/meter)	Measurement Distance (meters)
0.009~0.490	2400/F(KHz)	300
0.490~1.705	24000/F(KHz)	30
1.705~30.0	30	30
30~88	100	3
88~216	150	3
216~960	200	3
960~1000	500	3

Note: 1) At frequencies at or above 30 MHz, measurements may be performed at a distance other than what is specified provided: measurements are not made in the near field except where it can be shown that near field measurements are appropriate due to the characteristics of the device; and it can be demonstrated that the signal levels needed to be measured at the distance employed can be detected by the measurement equipment. Measurements shall not be performed at a distance greater than 30 meters unless it can be further demonstrated that measurements at a distance of 30 meters or less are impractical. When performing measurements at a distance other than that specified, the results shall be extrapolated to the specified distance using an extrapolation factor of 20 dB/decade (inverse linear-distance for field strength measurements; inverse-linear-distance-squared for power density measurements).

(2) At frequencies below 30 MHz, measurements may be performed at a distance closer than that specified in the regulations; however, an attempt should be made to avoid making measurements in the near field. Pending the development of an appropriate measurement procedure for measurements performed below 30 MHz, when performing measurements at a closer distance than specified, the results shall be extrapolated to the specified distance by either making measurements at a minimum of two distances on at least one radial to determine the proper extrapolation factor or by using the square of an inverse linear distance extrapolation factor (40 dB/decade). This paragraph (f) shall not apply to Access BPL devices operating below 30 MHz.



Radiation Disturbance Test Limit for FCC (Above 1G)

Frequency (MHz)	dB(uV/m) (at 3 meters)	
	Peak	Average
Above 1000	74	54

FCC Restricted bands of operation:

MHz	MHz	MHz	GHz
0.090-0.110	16.42-16.423	399.9-410	4.5-5.15
<sup>1</sup> 0.495-0.505	16.69475-16.69525	608-614	5.35-5.46
2.1735-2.1905	16.80425-16.80475	960-1240	7.25-7.75
4.125-4.128	25.5-25.67	1300-1427	8.025-8.5
4.17725-4.17775	37.5-38.25	1435-1626.5	9.0-9.2
4.20725-4.20775	73-74.6	1645.5-1646.5	9.3-9.5
6.215-6.218	74.8-75.2	1660-1710	10.6-12.7
6.26775-6.26825	108-121.94	1718.8-1722.2	13.25-13.4
6.31175-6.31225	123-138	2200-2300	14.47-14.5
8.291-8.294	149.9-150.05	2310-2390	15.35-16.2
8.362-8.366	156.52475-156.52525	2483.5-2500	17.7-21.4
8.37625-8.38675	156.7-156.9	2690-2900	22.01-23.12
8.41425-8.41475	162.0125-167.17	3260-3267	23.6-24.0
12.29-12.293	167.72-173.2	3332-3339	31.2-31.8
12.51975-12.52025	240-285	3345.8-3358	36.43-36.5
12.57675-12.57725	322-335.4	3600-4400	( <sup>2</sup> )
13.36-13.41			

Note: <sup>1</sup>Until February 1, 1999, this restricted band shall be 0.490-0.510 MHz.

<sup>2</sup>Above 38.6c

**TEST SETUP AND PROCEDURE**

Below 30MHz

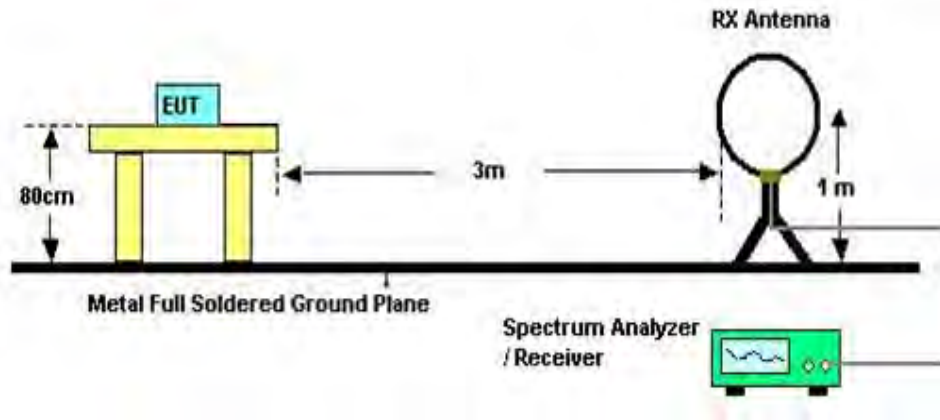

The setting of the spectrum analyser

RBW	200Hz (From 9kHz to 0.15MHz)/ 9KHz (From 0.15MHz to 30MHz)
VBW	200Hz (From 9kHz to 0.15MHz)/ 9KHz (From 0.15MHz to 30MHz)
Sweep	Auto
Detector	Peak/QP/ Average
Trace	Max hold

1. The testing follows the guidelines in ANSI C63.10-2013
2. The EUT was arranged to its worst case and then turntable (from 0 degree to 360 degrees) to find the maximum reading. A pre-amp and a high pass filter are used for the test in order to get better signal level. Both horizontal and vertical polarizations of the antenna are set to make the measurement.
3. The EUT was placed on a turntable with 0.8 meter above ground.
4. The EUT was set 3 meters from the interference receiving antenna, which was mounted on the top of a variable height antenna tower.
5. For measurement below 1GHz, the initial step in collecting conducted emission data is a spectrum analyzer peak detector mode pre-scanning the measurement frequency range. Significant peaks are then marked and then Quasi Peak detector mode re-measured. If the emission level of the EUT measured by the peak detector is 3 dB lower than the applicable limit, the peak emission level will be reported. Otherwise, the emission measurement will be repeated using the quasi-peak detector and reported.
6. Although these tests were performed other than open field site, adequate comparison measurements were confirmed against 30m open field site. Therefore sufficient tests were made to demonstrate that the alternative site produces results that correlate with the ones of tests made in an open field site based on KDB 414788.

Below 1G

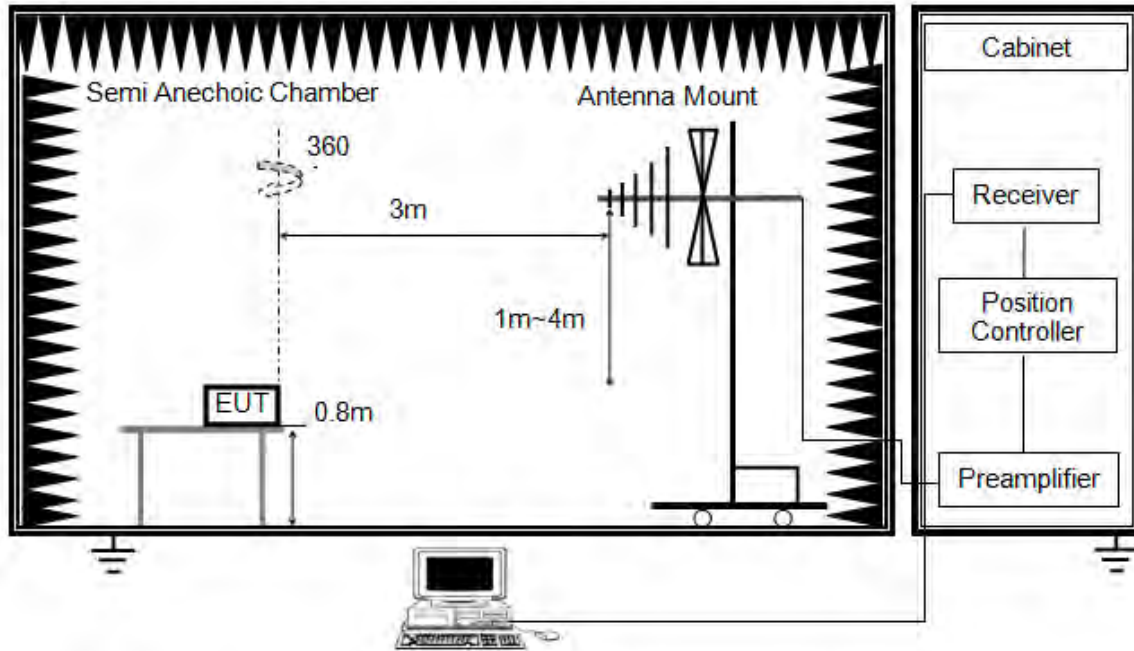

The setting of the spectrum analyser

RBW	120K
VBW	300K
Sweep	Auto
Detector	Peak/QP
Trace	Max hold

1. The testing follows the guidelines in ANSI C63.10-2013.
2. The EUT was arranged to its worst case and then tune the antenna tower (from 1 m to 4 m) and turntable (from 0 degree to 360 degrees) to find the maximum reading. A pre-amp and a high pass filter are used for the test in order to get better signal level. Both horizontal and vertical polarizations of the antenna are set to make the measurement.
3. The EUT was placed on a turntable with 0.8 meter above ground.
4. The EUT was set 3 meters from the interference receiving antenna, which was mounted on the top of a variable height antenna tower.
5. For measurement below 1GHz, the initial step in collecting conducted emission data is a spectrum analyzer peak detector mode pre-scanning the measurement frequency range. Significant peaks are then marked and then Quasi Peak detector mode re-measured. If the emission level of the EUT measured by the peak detector is 3 dB lower than the applicable limit, the peak emission level will be reported. Otherwise, the emission measurement will be repeated using the quasi-peak detector and reported.

ABOVE 1G

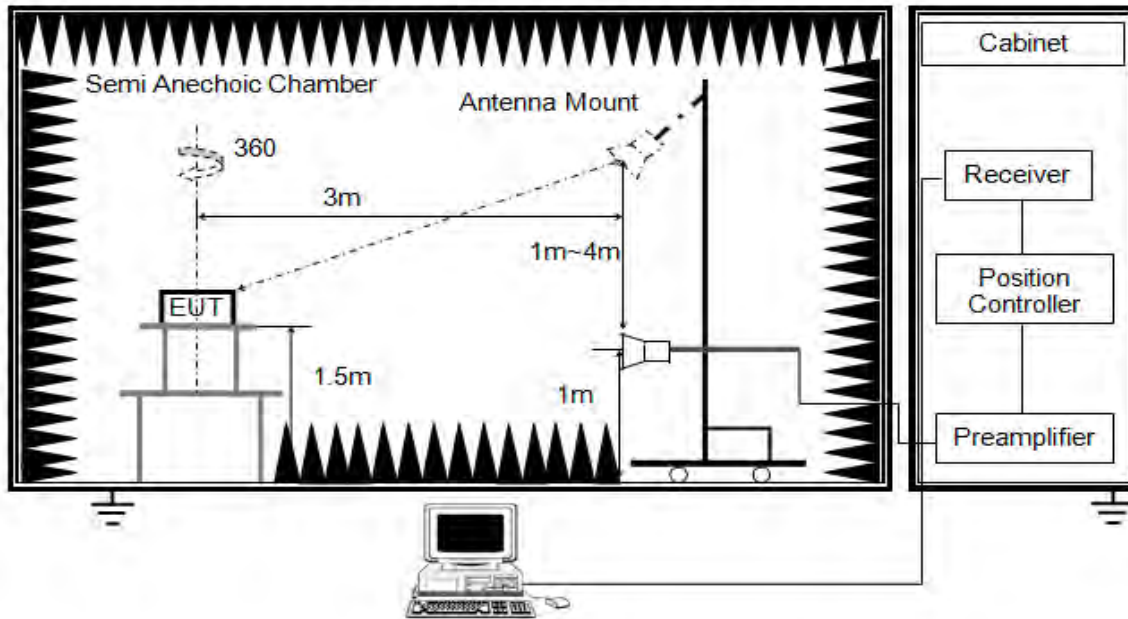

The setting of the spectrum analyser

RBW	1M
VBW	PEAK: 3M AVG: see note 6
Sweep	Auto
Detector	Peak
Trace	Max hold

1. The testing follows the guidelines in ANSI C63.10-2013.
2. The EUT was arranged to its worst case and then tune the antenna tower (from 1 m to 4 m) and turntable (from 0 degree to 360 degrees) to find the maximum reading. A pre-amp and a high pass filter are used for the test in order to get better signal level. Both horizontal and vertical polarizations of the antenna are set to make the measurement.
3. The EUT was placed on a turntable with 1.5m above ground.
4. The EUT was set 3 meters from the interference receiving antenna, which was mounted on the top of a variable height antenna tower.
5. For measurement above 1GHz, the emission measurement will be measured by the peak detector. This peak level, once corrected, must comply with the limit specified in Section 15.209.
6. For measurements above 1 GHz the resolution bandwidth is set to 1 MHz, then the video bandwidth is set to 3 MHz for peak measurements and 1 MHz resolution bandwidth with 1/T video bandwidth with peak detector for average measurements. For the Duty Cycle please refer to clause 8.1.ON TIME AND DUTY CYCLE.

X axis, Y axis, Z axis positions:

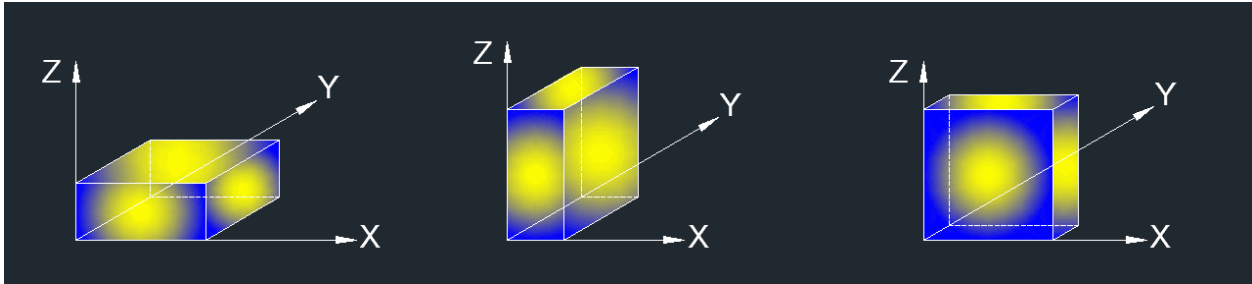

Note : For all radiated test, EUT in each of three orthogonal axis emissions had been tested, but only the worst case (X axis) data recorded in the report.

### **TEST ENVIRONMENT**

Temperature	20°C	Relative Humidity	56%
Atmosphere Pressure	101kPa	Test Voltage	DC 12V



## 9.1. RESTRICTED BANDEDGE

Test Result Table

Test Mode	Test Antenna	Channel	Puw(dBm)	Verdict
11B	Antenna 1	LCH	<Limit	PASS
		MCH	<Limit	PASS
		HCH	<Limit	PASS
11G	Antenna 1	LCH	<Limit	PASS
		MCH	<Limit	PASS
		HCH	<Limit	PASS
11N20	Antenna 1	LCH	<Limit	PASS
		MCH	<Limit	PASS
		HCH	<Limit	PASS
11N40	Antenna 1	LCH	<Limit	PASS
		MCH	<Limit	PASS
		HCH	<Limit	PASS



### 9.1.1. 802.11b MODE

#### RESTRICTED BANDEDGE (LOW CHANNEL, HORIZONTAL)

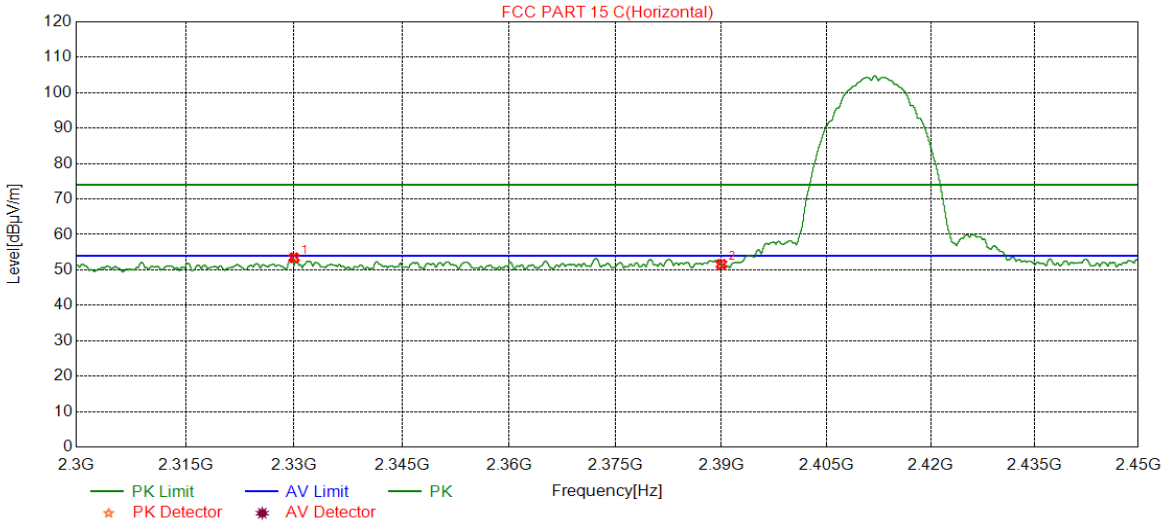

No.	Frequency (MHz)	Reading Level (dBuV/m)	Correct Factor (dB)	Result (dBuV/m)	Limit (dBuV/m)	Margin (dB)	Remark
1	2329.9880	39.94	13.46	53.40	74.00	-20.60	peak
2	2390.0000	37.47	14.09	51.56	74.00	-22.44	peak

- Note:
1. Measurement = Reading Level + Correct Factor.
  2. If Peak Result complies with AV limit, AV Result is deemed to comply with AV limit.
  3. Peak: Peak detector.
  4. Only the worst case emission was recorded, if it complies with the limit, the other emissions deemed to comply with the limit.





**RESTRICTED BANDEDGE (LOW CHANNEL, VERTICAL)**

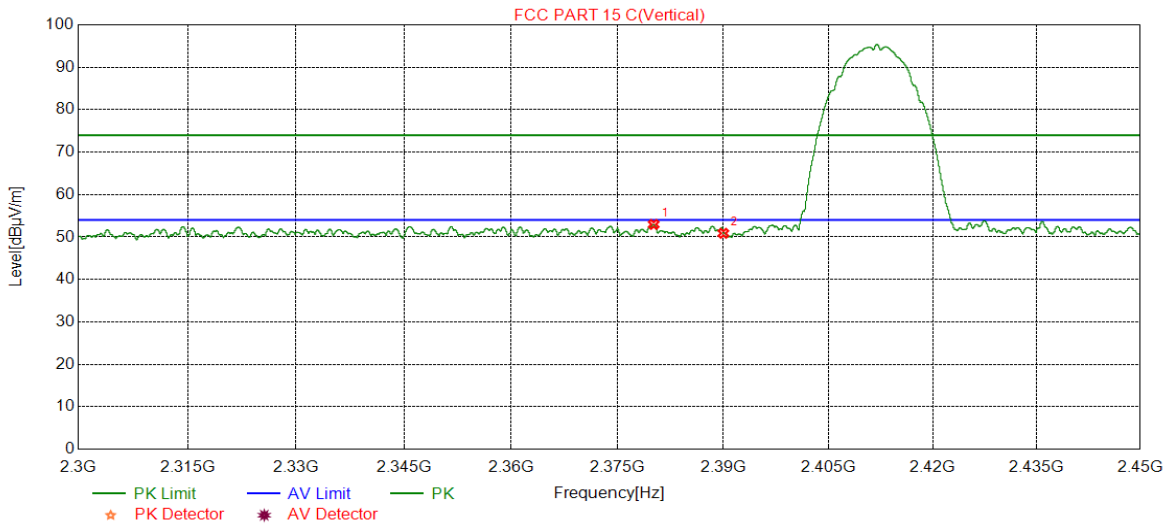

No.	Frequency (MHz)	Reading Level (dBuV/m)	Correct Factor (dB)	Result (dBuV/m)	Limit (dBuV/m)	Margin (dB)	Remark
1	2380.1080	38.95	14.01	52.96	74.00	-21.04	peak
2	2390.0000	36.78	14.09	50.87	74.00	-23.13	peak

- Note:
1. Measurement = Reading Level + Correct Factor.
  2. If Peak Result complies with AV limit, AV Result is deemed to comply with AV limit.
  3. Peak: Peak detector.
  4. Only the worst case emission was recorded, if it complies with the limit, the other emissions deemed to comply with the limit.



**RESTRICTED BANDEDGE (HIGH CHANNEL, HORIZONTAL)**

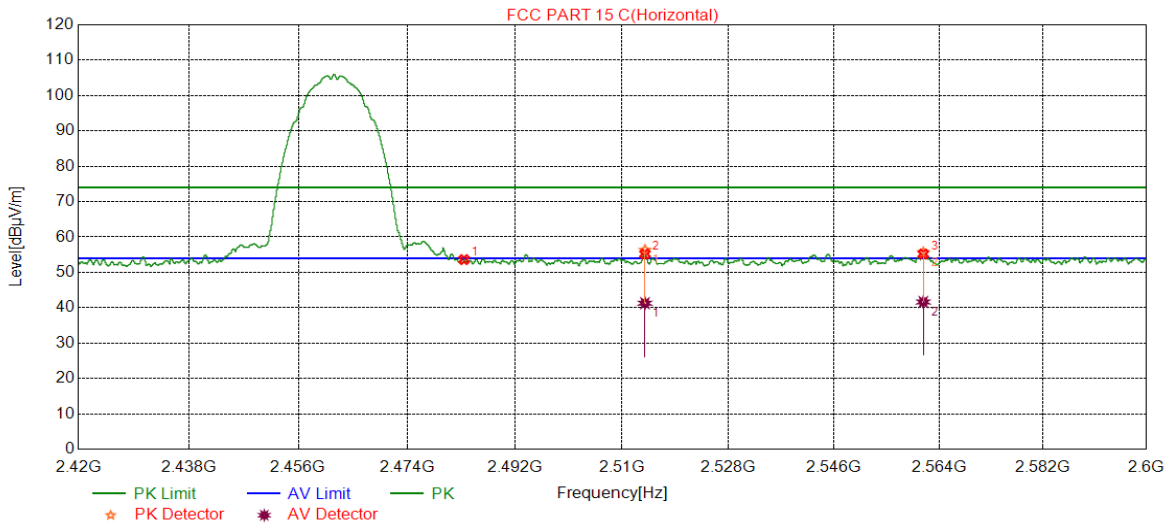

No.	Frequency (MHz)	Reading Level (dBuV/m)	Correct Factor (dB)	Result (dBuV/m)	Limit (dBuV/m)	Margin (dB)	Remark
1	2483.5000	39.72	13.88	53.60	74.00	-20.40	peak
2	2513.8614	42.08	14.20	56.28	74.00	-17.72	peak
		27.08	14.20	41.28	54.00	-12.72	average
3	2561.2961	41.15	14.47	55.62	74.00	-18.38	peak
		27.15	14.47	41.62	54.00	-12.38	average

- Note:
1. Measurement = Reading Level + Correct Factor.
  2. If Peak Result complies with AV limit, AV Result is deemed to comply with AV limit.
  3. Peak: Peak detector.
  4. Only the worst case emission was recorded, if it complies with the limit, the other emissions deemed to comply with the limit.



**RESTRICTED BANDEDGE (HIGH CHANNEL, VERTICAL)**

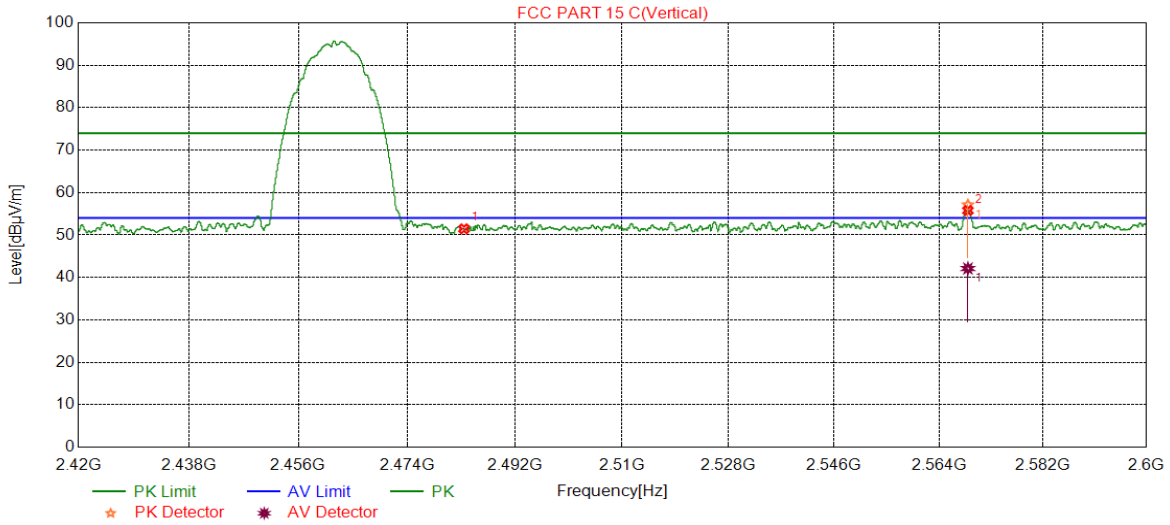

No.	Frequency (MHz)	Reading Level (dBuV/m)	Correct Factor (dB)	Result (dBuV/m)	Limit (dBuV/m)	Margin (dB)	Remark
1	2483.5000	37.58	13.88	51.46	74.00	-22.54	peak
2	2568.9829	42.66	14.44	57.10	74.00	-16.90	peak
		27.66	14.44	42.10	54.00	-11.90	average

- Note: 1. Measurement = Reading Level + Correct Factor.  
 2. If Peak Result complies with AV limit, AV Result is deemed to comply with AV limit.  
 3. Peak: Peak detector.  
 4. Only the worst case emission was recorded, if it complies with the limit, the other emissions deemed to comply with the limit.



### 9.1.2. 802.11g MODE

#### RESTRICTED BANDEDGE (LOW CHANNEL, HORIZONTAL)

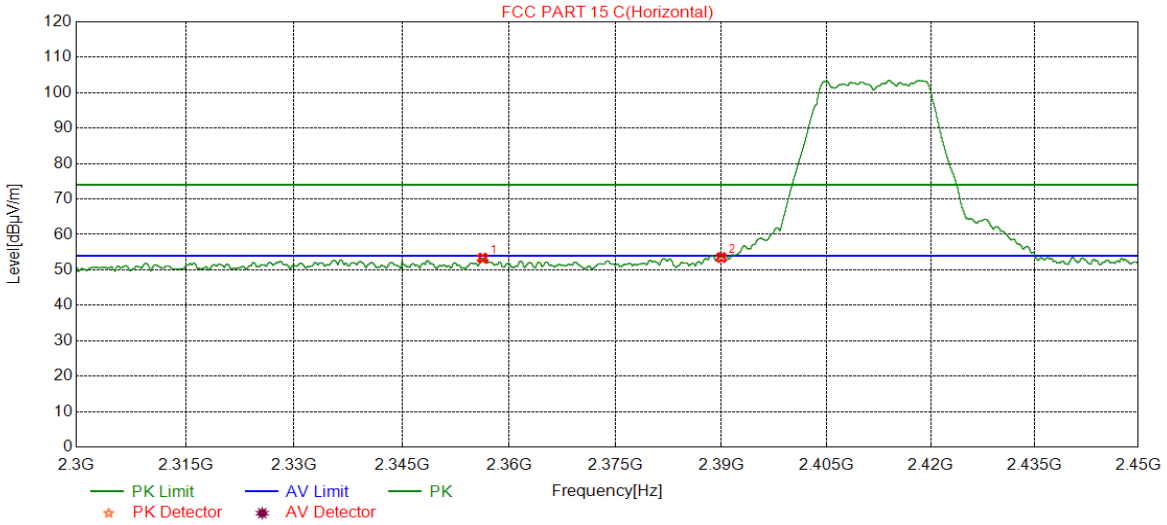

No.	Frequency (MHz)	Reading Level (dBuV/m)	Correct Factor (dB)	Result (dBuV/m)	Limit (dBuV/m)	Margin (dB)	Remark
1	2356.3006	39.61	13.71	53.32	74.00	-20.68	peak
2	2390.0000	39.39	14.09	53.48	74.00	-20.52	peak

- Note:
1. Measurement = Reading Level + Correct Factor.
  2. If Peak Result complies with AV limit, AV Result is deemed to comply with AV limit.
  3. Peak: Peak detector.
  4. Only the worst case emission was recorded, if it complies with the limit, the other emissions deemed to comply with the limit.



**RESTRICTED BANDEDGE (LOW CHANNEL, VERTICAL)**

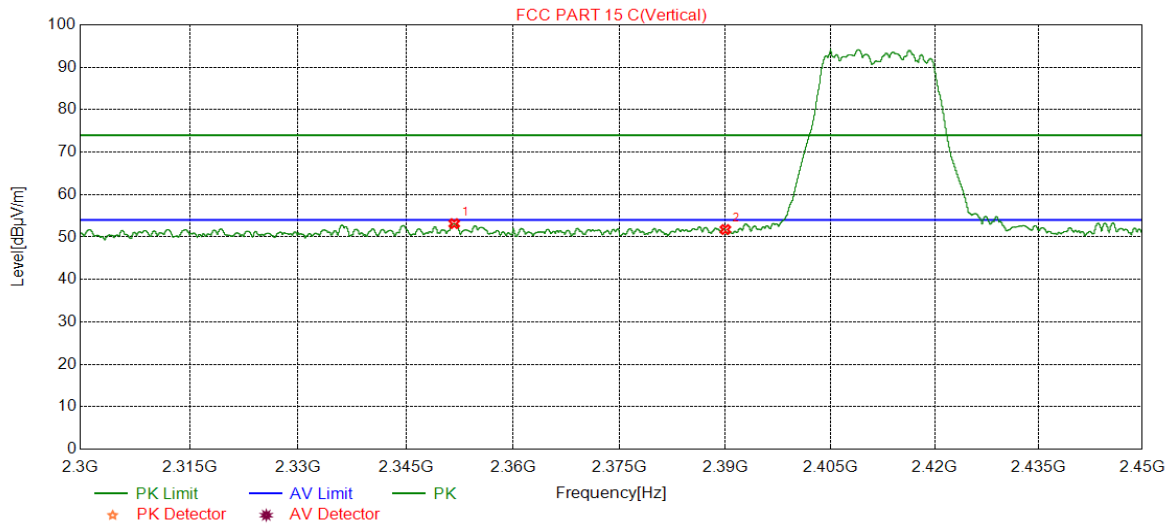

No.	Frequency (MHz)	Reading Level (dBuV/m)	Correct Factor (dB)	Result (dBuV/m)	Limit (dBuV/m)	Margin (dB)	Remark
1	2351.7402	39.47	13.68	53.15	74.00	-20.85	peak
2	2390.0000	37.67	14.09	51.76	74.00	-22.24	peak

- Note: 1. Measurement = Reading Level + Correct Factor.  
 2. If Peak Result complies with AV limit, AV Result is deemed to comply with AV limit.  
 3. Peak: Peak detector.  
 4. Only the worst case emission was recorded, if it complies with the limit, the other emissions deemed to comply with the limit.



**RESTRICTED BANDEDGE (HIGH CHANNEL, HORIZONTAL)**

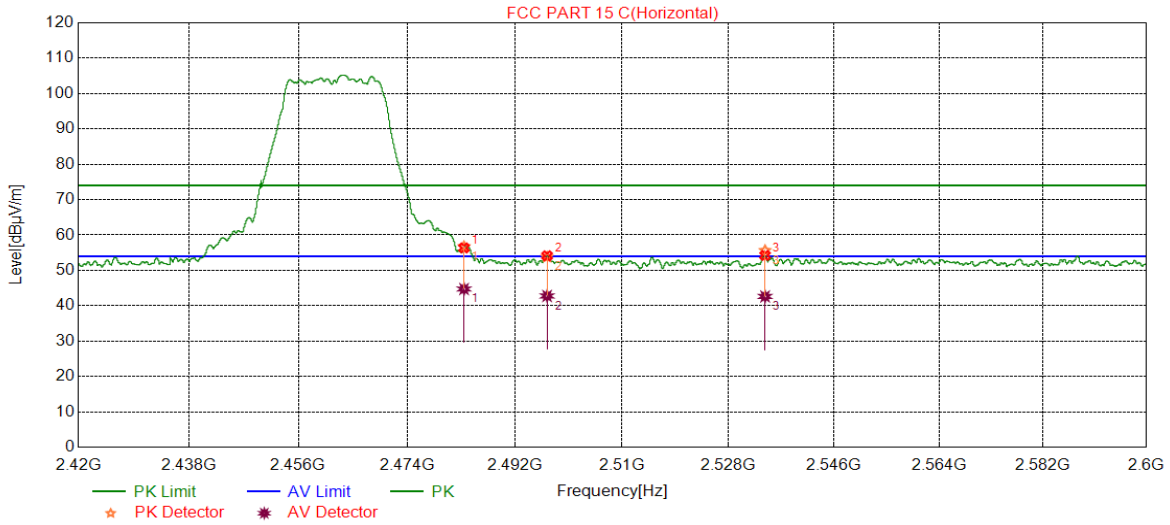

No.	Frequency (MHz)	Reading Level (dBuV/m)	Correct Factor (dB)	Result (dBuV/m)	Limit (dBuV/m)	Margin (dB)	Remark
1	2483.5000	42.85	13.88	56.73	74.00	-17.27	peak
		30.85	13.88	44.73	54.00	-9.27	average
2	2497.3897	39.71	14.05	53.76	74.00	-20.24	peak
		28.71	14.05	42.76	54.00	-11.24	average
3	2534.2214	41.32	14.30	55.62	74.00	-18.38	peak
		28.32	14.30	42.62	54.00	-11.38	average

- Note: 1. Measurement = Reading Level + Correct Factor.  
 2. If Peak Result complies with AV limit, AV Result is deemed to comply with AV limit.  
 3. Peak: Peak detector.  
 4. Only the worst case emission was recorded, if it complies with the limit, the other emissions deemed to comply with the limit.



**RESTRICTED BANDEDGE (HIGH CHANNEL, VERTICAL)**

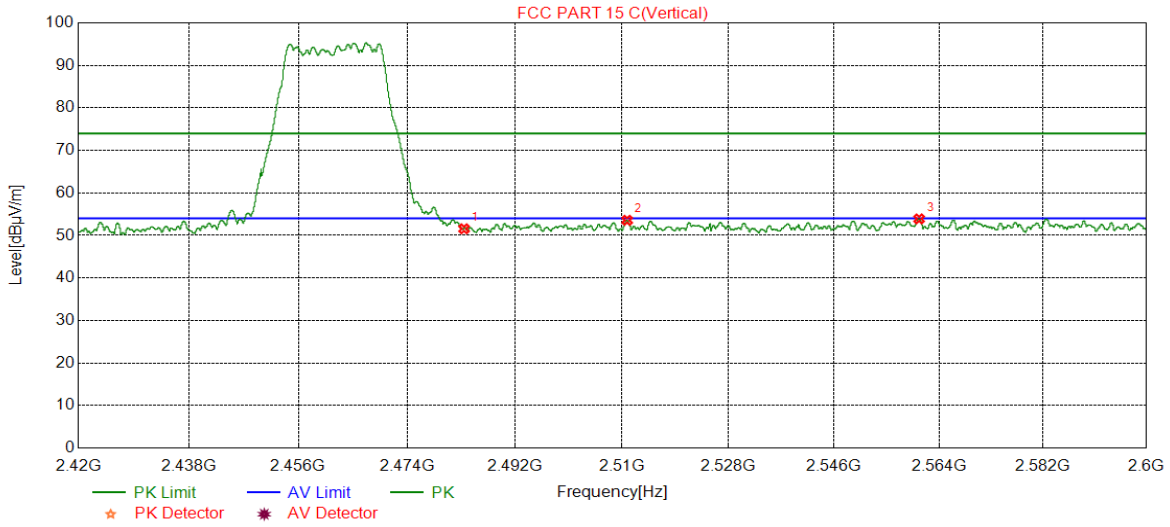

No.	Frequency (MHz)	Reading Level (dBuV/m)	Correct Factor (dB)	Result (dBuV/m)	Limit (dBuV/m)	Margin (dB)	Remark
1	2483.5000	37.68	13.88	51.56	74.00	-22.44	peak
2	2510.8551	39.32	14.24	53.56	74.00	-20.44	peak
3	2560.5761	39.43	14.46	53.89	74.00	-20.11	peak

- Note:
1. Measurement = Reading Level + Correct Factor.
  2. If Peak Result complies with AV limit, AV Result is deemed to comply with AV limit.
  3. Peak: Peak detector.
  4. Only the worst case emission was recorded, if it complies with the limit, the other emissions deemed to comply with the limit.



### 9.1.3. 802.11n HT20 MODE

#### RESTRICTED BANDEDGE (LOW CHANNEL, HORIZONTAL)

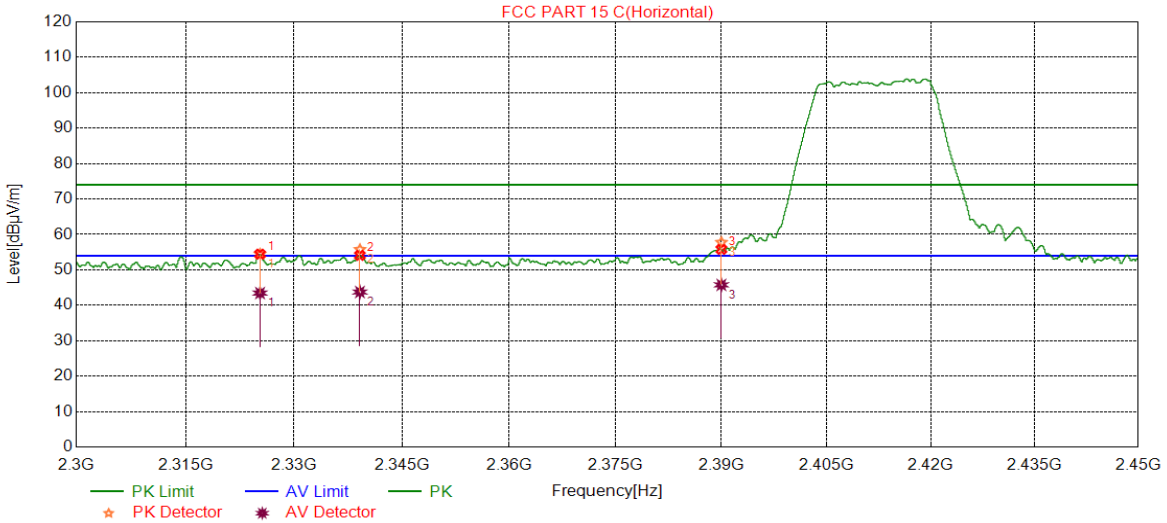

No.	Frequency (MHz)	Reading Level (dBuV/m)	Correct Factor (dB)	Result (dBuV/m)	Limit (dBuV/m)	Margin (dB)	Remark
1	2325.2775	41.07	13.38	54.45	74.00	-19.55	peak
		30.07	13.38	43.45	54.00	-10.55	average
2	2339.1389	42.19	13.56	55.75	74.00	-18.25	peak
		30.19	13.56	43.75	54.00	-10.25	average
3	2390.0000	43.67	14.09	57.76	74.00	-16.24	peak
		31.67	14.09	45.76	54.00	-8.24	average

- Note: 1. Measurement = Reading Level + Correct Factor.  
 2. If Peak Result complies with AV limit, AV Result is deemed to comply with AV limit.  
 3. Peak: Peak detector.  
 4. Only the worst case emission was recorded, if it complies with the limit, the other emissions deemed to comply with the limit.





**RESTRICTED BANDEDGE (LOW CHANNEL, VERTICAL)**

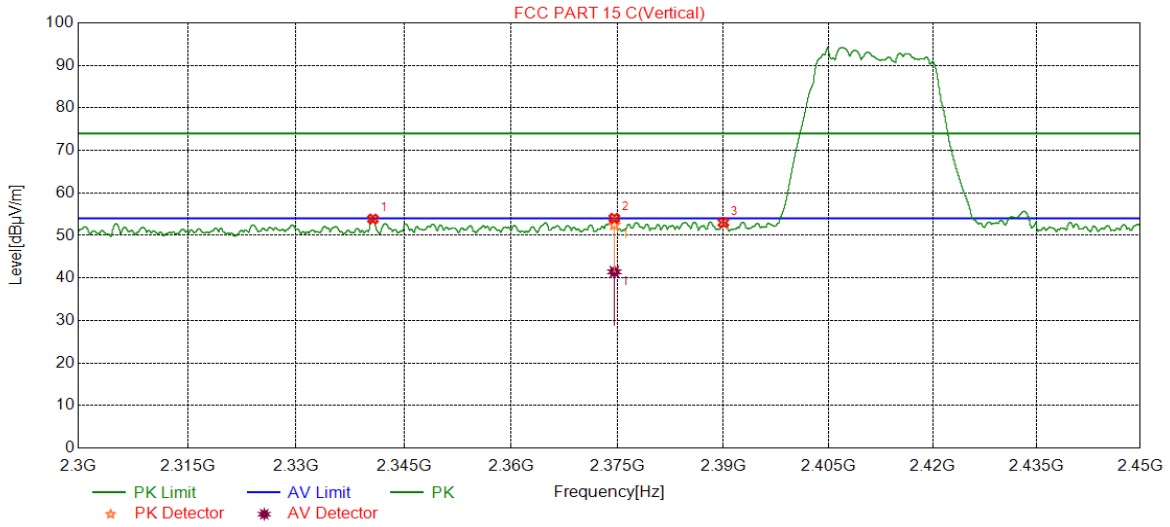

No.	Frequency (MHz)	Reading Level (dBuV/m)	Correct Factor (dB)	Result (dBuV/m)	Limit (dBuV/m)	Margin (dB)	Remark
1	2340.6691	40.27	13.59	53.86	74.00	-20.14	peak
2	2374.5425	38.51	13.93	52.44	74.00	-21.56	peak
		27.51	13.93	41.44	54.00	-12.56	average
3	2390.0000	38.93	14.09	53.02	74.00	-20.98	peak

- Note:
1. Measurement = Reading Level + Correct Factor.
  2. If Peak Result complies with AV limit, AV Result is deemed to comply with AV limit.
  3. Peak: Peak detector.
  4. Only the worst case emission was recorded, if it complies with the limit, the other emissions deemed to comply with the limit.



**RESTRICTED BANDEDGE (HIGH CHANNEL, HORIZONTAL)**

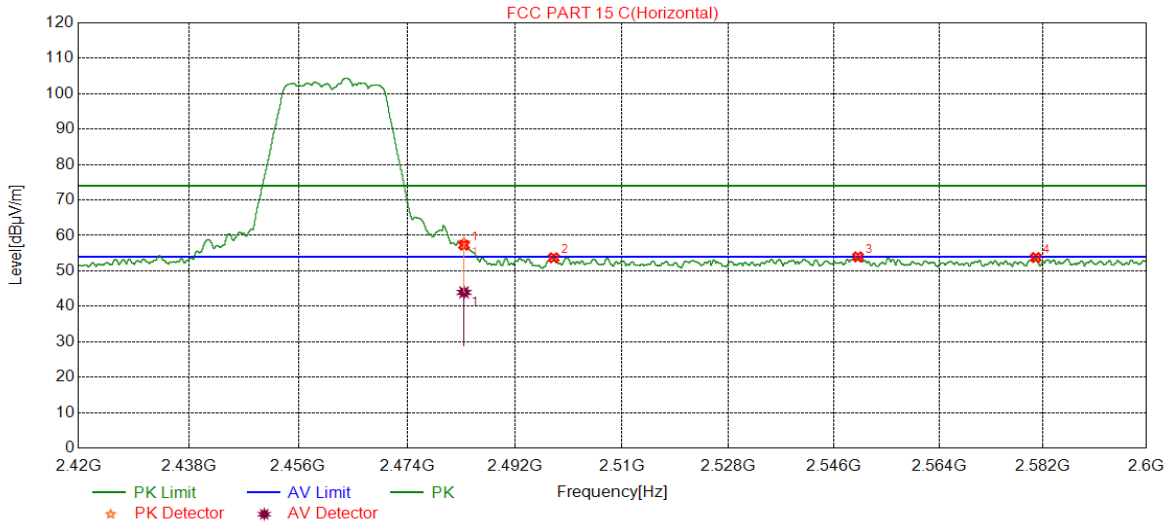

No.	Frequency (MHz)	Reading Level (dBuV/m)	Correct Factor (dB)	Result (dBuV/m)	Limit (dBuV/m)	Margin (dB)	Remark
1	2483.5000	44.05	13.88	57.93	74.00	-16.07	peak
		30.05	13.88	43.93	54.00	-10.07	average
2	2498.5059	39.61	14.08	53.69	74.00	-20.31	peak
3	2550.0810	39.53	14.42	53.95	74.00	-20.05	peak
4	2580.7381	39.31	14.45	53.76	74.00	-20.24	peak

- Note: 1. Measurement = Reading Level + Correct Factor.  
 2. If Peak Result complies with AV limit, AV Result is deemed to comply with AV limit.  
 3. Peak: Peak detector.  
 4. Only the worst case emission was recorded, if it complies with the limit, the other emissions deemed to comply with the limit.



**RESTRICTED BANDEDGE (HIGH CHANNEL, VERTICAL)**

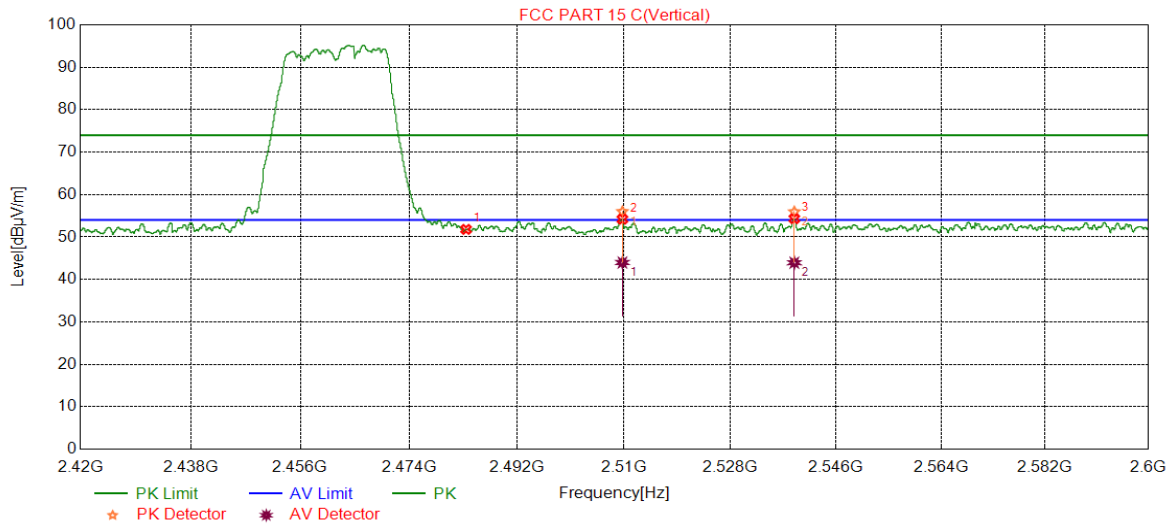

No.	Frequency (MHz)	Reading Level (dBuV/m)	Correct Factor (dB)	Result (dBuV/m)	Limit (dBuV/m)	Margin (dB)	Remark
1	2483.5000	37.91	13.88	51.79	74.00	-22.21	peak
2	2509.7210	41.77	14.22	55.99	74.00	-18.01	peak
		29.76	14.22	43.98	54.00	-10.02	average
3	2538.8659	41.66	14.28	55.94	74.00	-18.06	peak
		29.66	14.28	43.94	54.00	-10.06	average

- Note: 1. Measurement = Reading Level + Correct Factor.  
 2. If Peak Result complies with AV limit, AV Result is deemed to comply with AV limit.  
 3. Peak: Peak detector.  
 4. Only the worst case emission was recorded, if it complies with the limit, the other emissions deemed to comply with the limit.



### 9.1.1. 802.11n HT40 MODE

#### RESTRICTED BANDEDGE (LOW CHANNEL, HORIZONTAL)

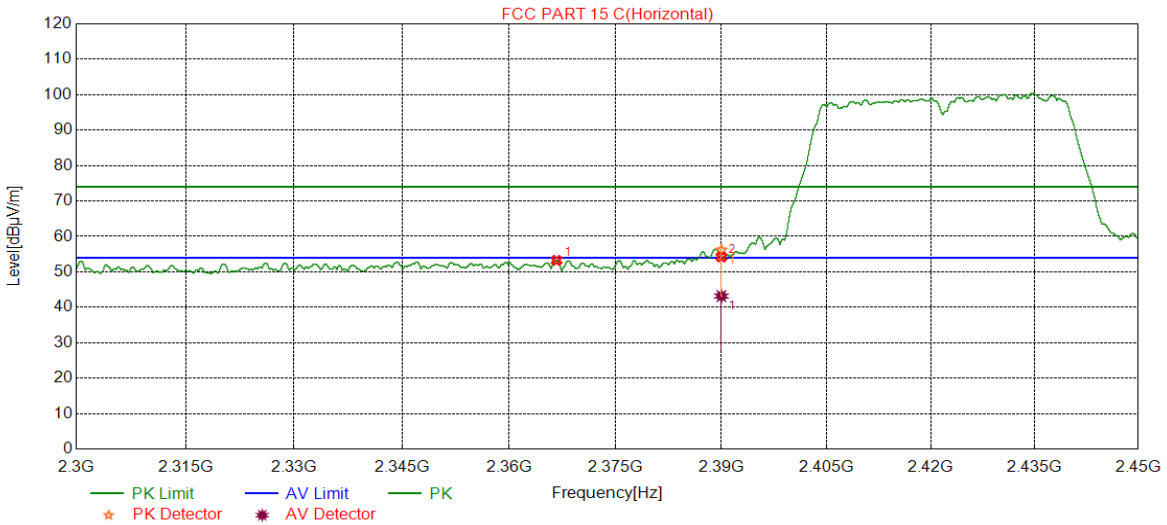

No.	Frequency (MHz)	Reading Level (dBuV/m)	Correct Factor (dB)	Result (dBuV/m)	Limit (dBuV/m)	Margin (dB)	Remark
1	2366.6667	39.43	13.81	53.24	74.00	-20.76	peak
2	2390.0000	42.08	14.09	56.17	74.00	-17.83	peak
		29.08	14.09	43.17	54.00	-10.83	average

- Note:
1. Measurement = Reading Level + Correct Factor.
  2. If Peak Result complies with AV limit, AV Result is deemed to comply with AV limit.
  3. Peak: Peak detector.
  4. Only the worst case emission was recorded, if it complies with the limit, the other emissions deemed to comply with the limit.



**RESTRICTED BANDEDGE (LOW CHANNEL, VERTICAL)**

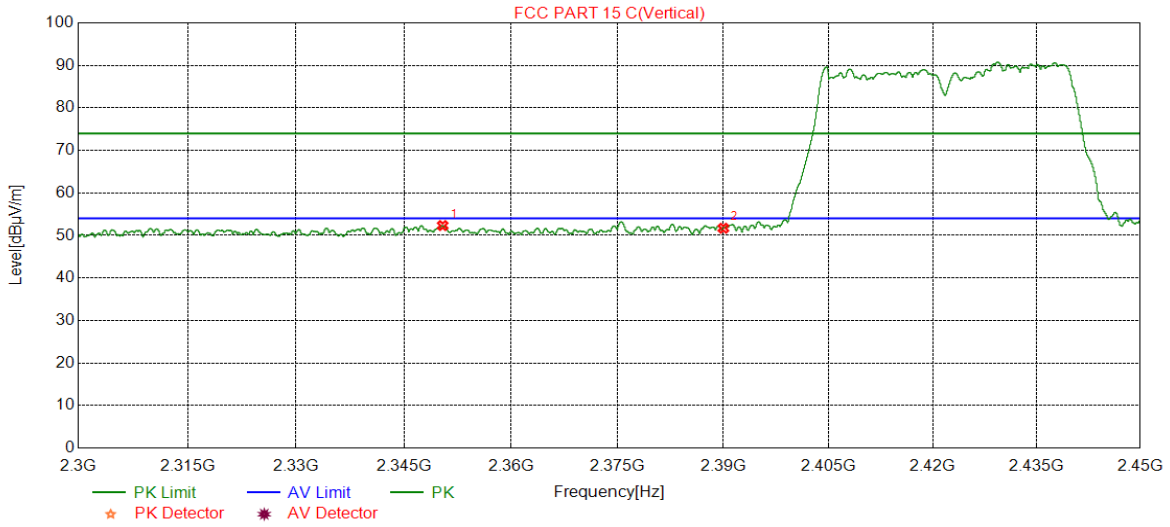

No.	Frequency (MHz)	Reading Level (dBuV/m)	Correct Factor (dB)	Result (dBuV/m)	Limit (dBuV/m)	Margin (dB)	Remark
1	2350.4050	38.64	13.68	52.32	74.00	-21.68	peak
2	2390.0000	37.61	14.09	51.70	74.00	-22.30	peak

- Note:
1. Measurement = Reading Level + Correct Factor.
  2. If Peak Result complies with AV limit, AV Result is deemed to comply with AV limit.
  3. Peak: Peak detector.
  4. Only the worst case emission was recorded, if it complies with the limit, the other emissions deemed to comply with the limit.



**RESTRICTED BANDEDGE (HIGH CHANNEL, HORIZONTAL)**

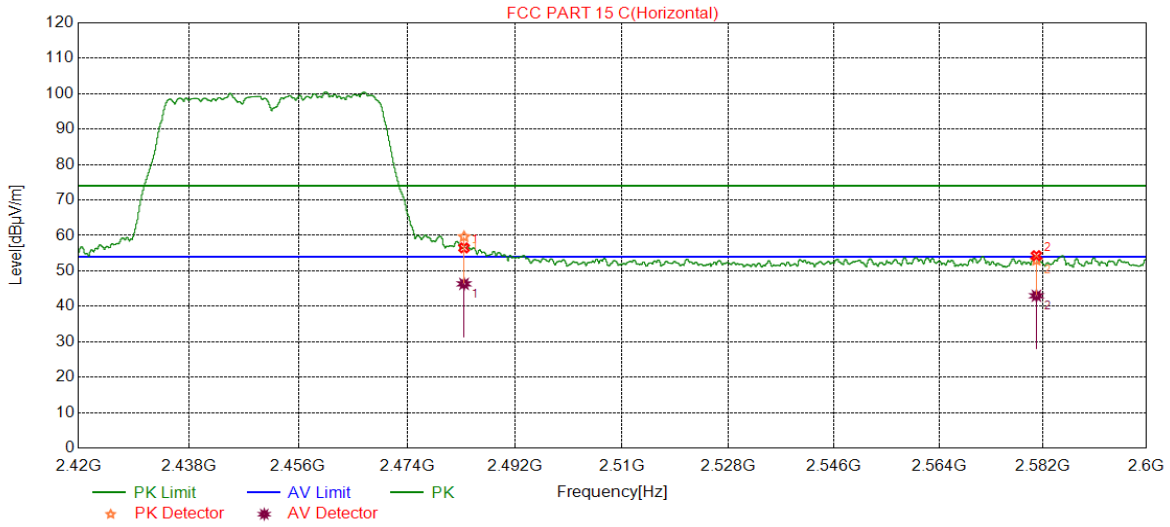

No.	Frequency (MHz)	Reading Level (dBuV/m)	Correct Factor (dB)	Result (dBuV/m)	Limit (dBuV/m)	Margin (dB)	Remark
1	2483.5000	45.77	13.88	59.65	74.00	-14.35	peak
		32.44	13.88	46.32	54.00	-7.68	average
2	2580.8281	38.52	14.45	52.97	74.00	-21.03	peak
		28.52	14.45	42.97	54.00	-11.03	average

- Note:
1. Measurement = Reading Level + Correct Factor.
  2. If Peak Result complies with AV limit, AV Result is deemed to comply with AV limit.
  3. Peak: Peak detector.
  4. Only the worst case emission was recorded, if it complies with the limit, the other emissions deemed to comply with the limit.



**RESTRICTED BANDEDGE (HIGH CHANNEL, VERTICAL)**

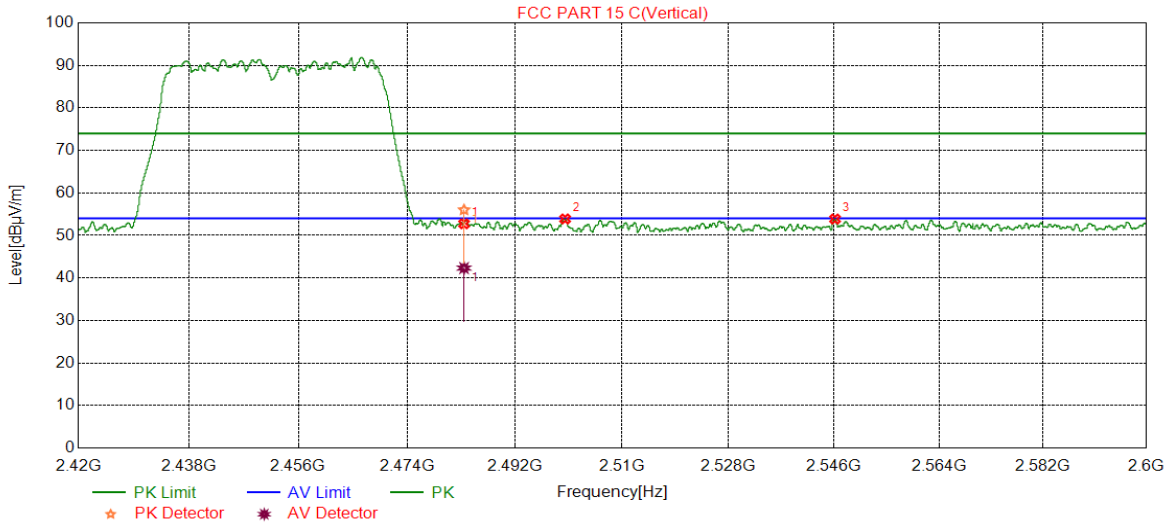

No.	Frequency (MHz)	Reading Level (dBuV/m)	Correct Factor (dB)	Result (dBuV/m)	Limit (dBuV/m)	Margin (dB)	Remark
1	2483.5000	42.13	13.88	56.01	74.00	-17.99	peak
		28.44	13.88	42.32	54.00	-11.68	average
2	2500.4140	39.76	14.12	53.88	74.00	-20.12	peak
3	2546.1566	39.50	14.36	53.86	74.00	-20.14	peak

- Note:
1. Measurement = Reading Level + Correct Factor.
  2. If Peak Result complies with AV limit, AV Result is deemed to comply with AV limit.
  3. Peak: Peak detector.
  4. Only the worst case emission was recorded, if it complies with the limit, the other emissions deemed to comply with the limit.



## 9.2. SPURIOUS EMISSIONS (1~18GHz)

### 9.2.1. 802.11b MODE

#### HARMONICS AND SPURIOUS EMISSIONS (LOW CHANNEL, HORIZONTAL)

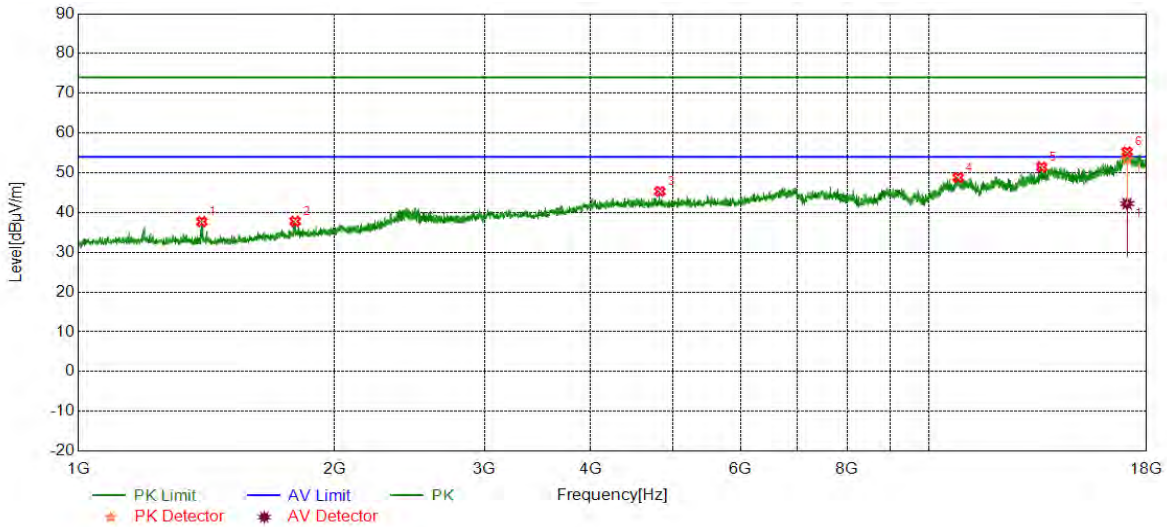

No.	Frequency (MHz)	Reading Level (dBuV/m)	Correct Factor (dB)	Result (dBuV/m)	Limit (dBuV/m)	Margin (dB)	Remark
1	1396.7989	43.32	-5.61	37.71	74.00	-36.29	peak
2	1797.5992	41.70	-3.90	37.80	74.00	-36.20	peak
3	4822.8038	40.37	4.94	45.31	74.00	-28.69	peak
4	10811.3019	35.97	12.84	48.81	74.00	-25.19	peak
5	13551.7586	36.61	14.83	51.44	74.00	-22.56	peak
6	17072.3454	33.13	20.28	53.41	74.00	-20.59	peak
		21.98	20.28	42.26	54.00	-11.74	average

- Note: 1. Measurement = Reading Level + Correct Factor.  
 2. If Peak Result complies with AV limit, AV Result is deemed to comply with AV limit.  
 3. Peak: Peak detector.  
 4. Only the worst case emission was recorded, if it complies with the limit, the other emissions deemed to comply with the limit.





**HARMONICS AND SPURIOUS EMISSIONS (LOW CHANNEL, VERTICAL)**

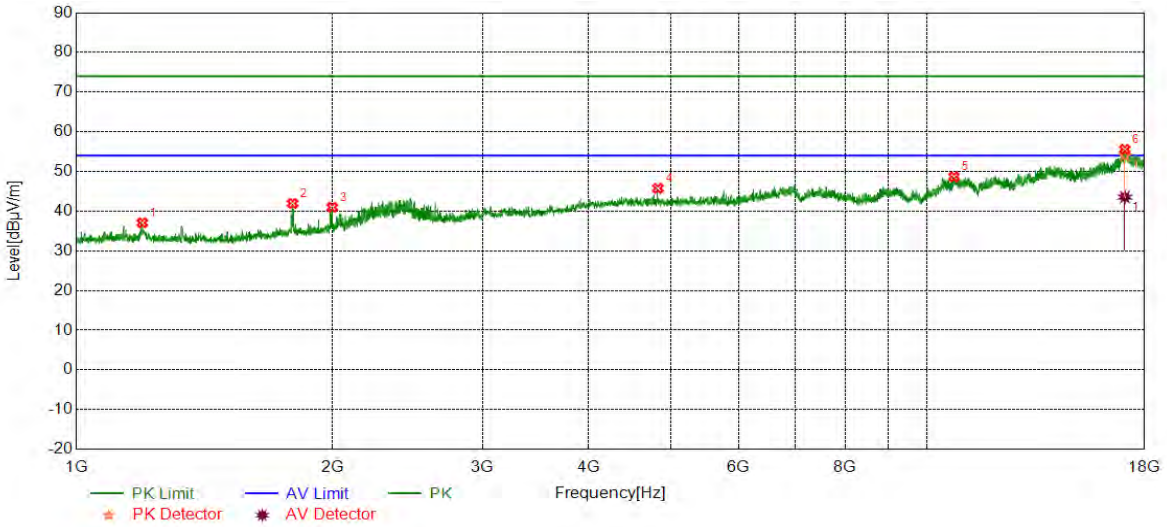

No.	Frequency (MHz)	Reading Level (dBuV/m)	Correct Factor (dB)	Result (dBuV/m)	Limit (dBuV/m)	Margin (dB)	Remark
1	1195.3985	42.61	-5.54	37.07	74.00	-36.93	peak
2	1794.9316	45.88	-3.93	41.95	74.00	-32.05	peak
3	1998.3328	44.01	-3.03	40.98	74.00	-33.02	peak
4	4822.8038	40.81	4.94	45.75	74.00	-28.25	peak
5	10748.7915	35.90	12.76	48.66	74.00	-25.34	peak
6	17062.3437	33.43	20.52	53.95	74.00	-20.05	peak
		23.01	20.52	43.53	54.00	-10.47	average

- Note: 1. Measurement = Reading Level + Correct Factor.  
 2. If Peak Result complies with AV limit, AV Result is deemed to comply with AV limit.  
 3. Peak: Peak detector.  
 4. Only the worst case emission was recorded, if it complies with the limit, the other emissions deemed to comply with the limit.



**HARMONICS AND SPURIOUS EMISSIONS (MID CHANNEL, HORIZONTAL)**

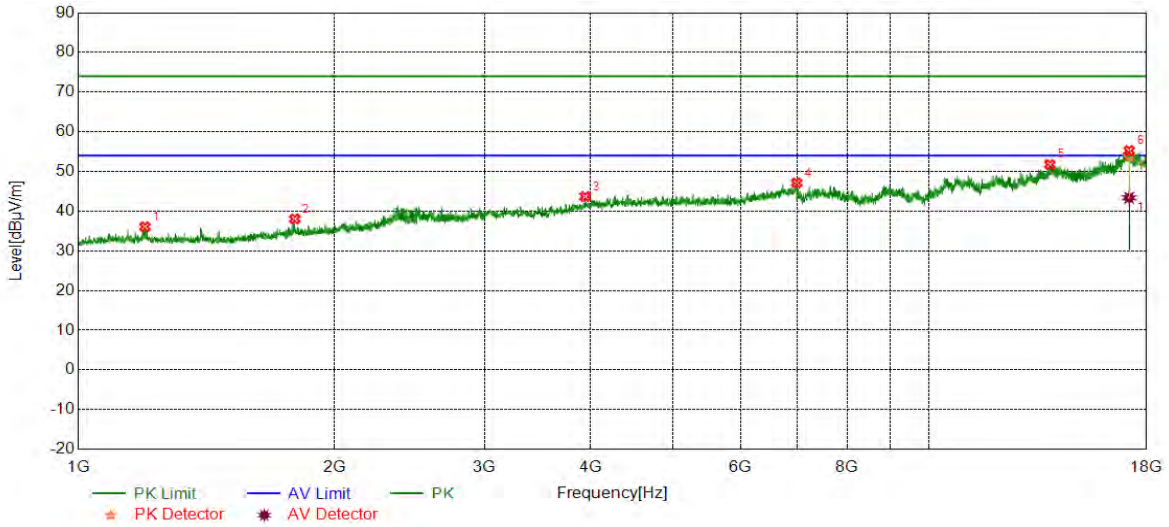

No.	Frequency (MHz)	Reading Level (dBuV/m)	Correct Factor (dB)	Result (dBuV/m)	Limit (dBuV/m)	Margin (dB)	Remark
1	1197.3991	41.59	-5.54	36.05	74.00	-37.95	peak
2	1796.2654	41.97	-3.92	38.05	74.00	-35.95	peak
3	3940.1567	38.94	4.73	43.67	74.00	-30.33	peak
4	6983.1639	38.57	8.55	47.12	74.00	-26.88	peak
5	13854.3091	36.12	15.67	51.79	74.00	-22.21	peak
6	17167.3612	34.27	19.51	53.78	74.00	-20.22	peak
		23.86	19.51	43.37	54.00	-10.63	average

Note: 1. Measurement = Reading Level + Correct Factor.  
 2. If Peak Result complies with AV limit, AV Result is deemed to comply with AV limit.  
 3. Peak: Peak detector.  
 4. Only the worst case emission was recorded, if it complies with the limit, the other emissions deemed to comply with the limit.



**HARMONICS AND SPURIOUS EMISSIONS (MID CHANNEL, VERTICAL)**

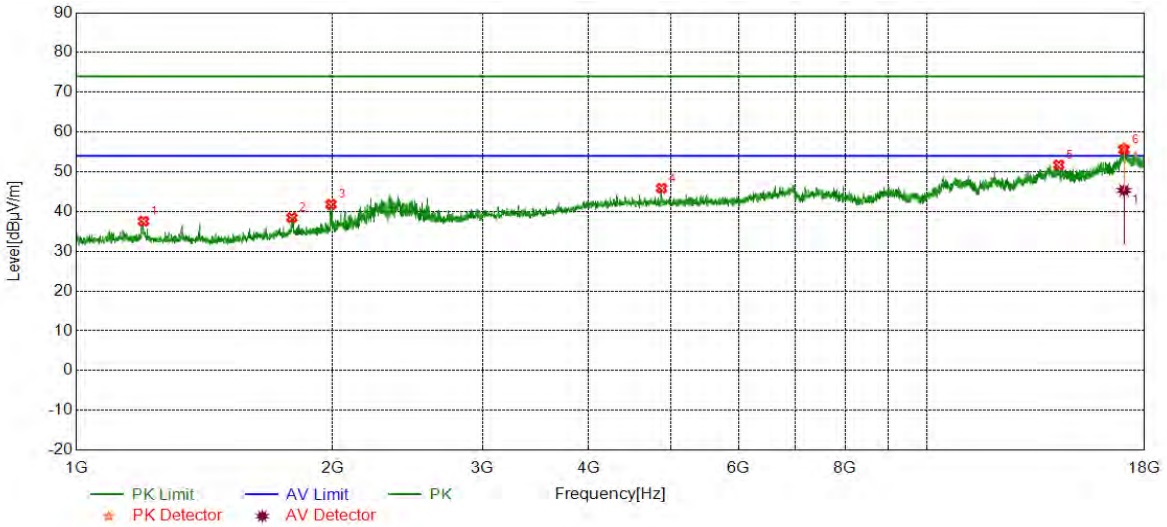

No.	Frequency (MHz)	Reading Level (dBuV/m)	Correct Factor (dB)	Result (dBuV/m)	Limit (dBuV/m)	Margin (dB)	Remark
1	1199.3998	43.11	-5.54	37.57	74.00	36.43	peak
2	1791.5972	42.43	-3.97	38.46	74.00	35.54	peak
3	1991.6639	44.89	-3.09	41.80	74.00	32.20	peak
4	4872.8121	40.65	5.21	45.86	74.00	28.14	peak
5	14271.8786	36.17	15.58	51.75	74.00	22.25	peak
6	17024.8375	35.90	20.19	56.09	74.00	17.91	peak
		25.14	20.19	45.33	54.00	8.67	average

- Note:
1. Measurement = Reading Level + Correct Factor.
  2. If Peak Result complies with AV limit, AV Result is deemed to comply with AV limit.
  3. Peak: Peak detector.
  4. Only the worst case emission was recorded, if it complies with the limit, the other emissions deemed to comply with the limit.



**HARMONICS AND SPURIOUS EMISSIONS (HIGH CHANNEL, HORIZONTAL)**

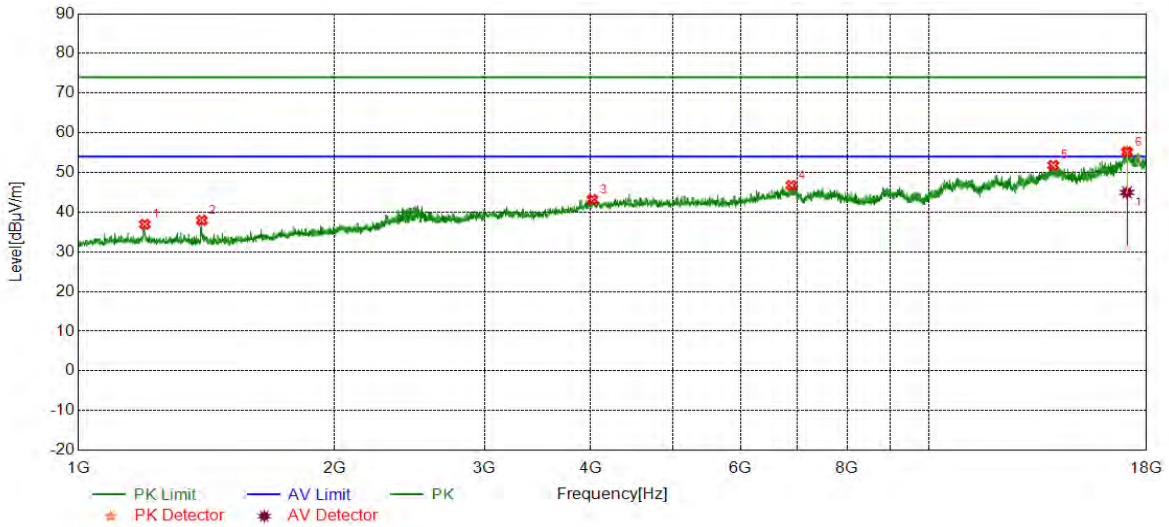

No.	Frequency (MHz)	Reading Level (dBuV/m)	Correct Factor (dB)	Result (dBuV/m)	Limit (dBuV/m)	Margin (dB)	Remark
1	1196.7322	42.48	-5.54	36.94	74.00	-37.06	peak
2	1396.7989	43.56	-5.61	37.95	74.00	-36.05	peak
3	4017.6696	38.75	4.44	43.19	74.00	-30.81	peak
4	6883.1472	38.31	8.43	46.74	74.00	-27.26	peak
5	13981.8303	35.33	16.48	51.81	74.00	-22.19	peak
6	17069.8450	34.81	20.52	55.33	74.00	-18.67	peak
		24.45	20.52	44.97	54.00	-9.03	average

- Note: 1. Measurement = Reading Level + Correct Factor.  
 2. If Peak Result complies with AV limit, AV Result is deemed to comply with AV limit.  
 3. Peak: Peak detector.  
 4. Only the worst case emission was recorded, if it complies with the limit, the other emissions deemed to comply with the limit.



**HARMONICS AND SPURIOUS EMISSIONS (HIGH CHANNEL, VERTICAL)**

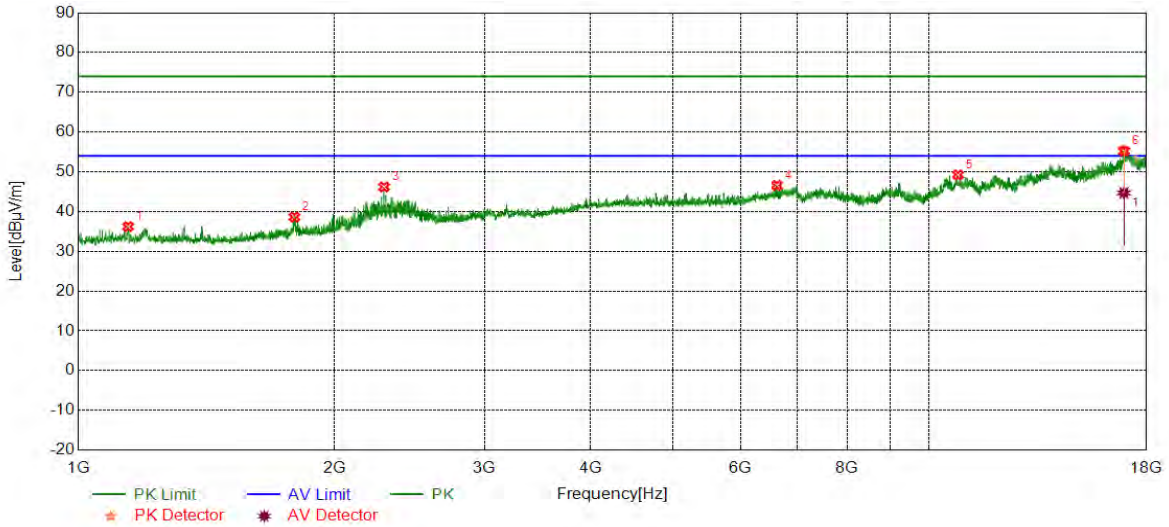

No.	Frequency (MHz)	Reading Level (dBuV/m)	Correct Factor (dB)	Result (dBuV/m)	Limit (dBuV/m)	Margin (dB)	Remark
1	1144.0480	41.75	-5.53	36.22	74.00	-37.78	peak
2	1794.2648	42.56	-3.94	38.62	74.00	-35.38	peak
3	2286.4288	48.25	-2.06	46.19	74.00	-27.81	peak
4	6620.6034	38.23	8.36	46.59	74.00	-27.41	peak
5	10806.3011	36.30	12.93	49.23	74.00	-24.77	peak
6	16927.3212	36.45	18.97	55.42	74.00	-18.58	peak
		25.74	18.97	44.71	54.00	-9.29	average

- Note: 1. Measurement = Reading Level + Correct Factor.  
 2. If Peak Result complies with AV limit, AV Result is deemed to comply with AV limit.  
 3. Peak: Peak detector.  
 4. Only the worst case emission was recorded, if it complies with the limit, the other emissions deemed to comply with the limit.



### 9.2.2. 802.11g MODE

#### HARMONICS AND SPURIOUS EMISSIONS (LOW CHANNEL, HORIZONTAL)

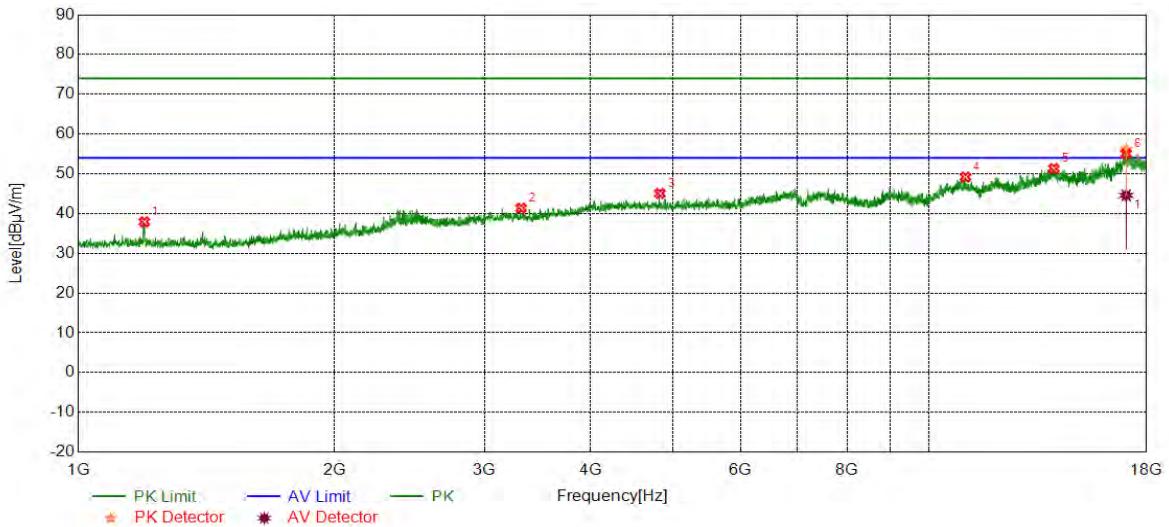

No.	Frequency (MHz)	Reading Level (dBuV/m)	Correct Factor (dB)	Result (dBuV/m)	Limit (dBuV/m)	Margin (dB)	Remark
1	1195.3985	43.46	-5.54	37.92	74.00	-36.08	peak
2	3312.5521	39.50	1.86	41.36	74.00	-32.64	peak
3	4822.8038	40.12	4.94	45.06	74.00	-28.94	peak
4	11026.3377	36.13	13.05	49.18	74.00	-24.82	peak
5	14001.8336	35.51	15.81	51.32	74.00	-22.68	peak
6	17029.8383	35.88	20.22	56.10	74.00	-17.90	peak
		24.36	20.22	44.58	54.00	-9.42	average

- Note: 1. Measurement = Reading Level + Correct Factor.  
 2. If Peak Result complies with AV limit, AV Result is deemed to comply with AV limit.  
 3. Peak: Peak detector.  
 4. Only the worst case emission was recorded, if it complies with the limit, the other emissions deemed to comply with the limit.



**HARMONICS AND SPURIOUS EMISSIONS (LOW CHANNEL, VERTICAL)**

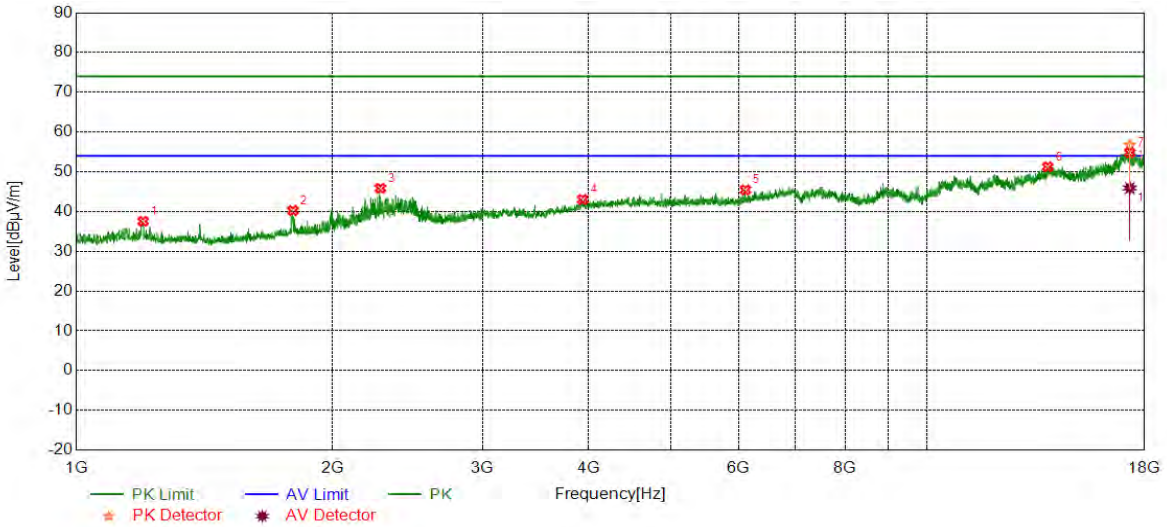

No.	Frequency (MHz)	Reading Level (dBuV/m)	Correct Factor (dB)	Result (dBuV/m)	Limit (dBuV/m)	Margin (dB)	Remark
1	1198.0660	43.09	-5.54	37.55	74.00	-36.45	peak
2	1796.9323	44.16	-3.91	40.25	74.00	-33.75	peak
3	2276.4255	47.96	-2.12	45.84	74.00	-28.16	peak
4	3935.1559	38.50	4.56	43.06	74.00	-30.94	peak
5	6113.0188	39.38	6.08	45.46	74.00	-28.54	peak
6	13846.8078	35.71	15.56	51.27	74.00	-22.73	peak
7	17292.3821	37.87	18.86	56.73	74.00	-17.27	peak
		27.07	18.86	45.93	54.00	-8.07	average

- Note: 1. Measurement = Reading Level + Correct Factor.  
 2. If Peak Result complies with AV limit, AV Result is deemed to comply with AV limit.  
 3. Peak: Peak detector.  
 4. Only the worst case emission was recorded, if it complies with the limit, the other emissions deemed to comply with the limit.



**HARMONICS AND SPURIOUS EMISSIONS (MID CHANNEL, HORIZONTAL)**

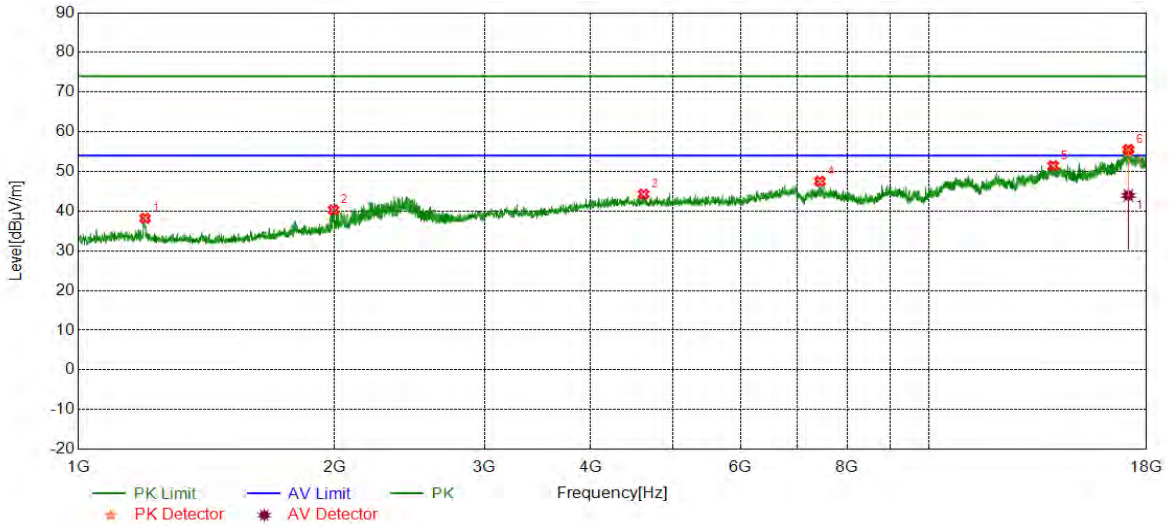

No.	Frequency (MHz)	Reading Level (dBuV/m)	Correct Factor (dB)	Result (dBuV/m)	Limit (dBuV/m)	Margin (dB)	Remark
1	1198.0660	43.76	-5.54	38.22	74.00	-35.78	peak
2	1994.3314	43.38	-3.07	40.31	74.00	-33.69	peak
3	4615.2692	39.20	5.07	44.27	74.00	-29.73	peak
4	7435.7393	38.22	9.31	47.53	74.00	-26.47	peak
5	13979.3299	34.94	16.51	51.45	74.00	-22.55	peak
6	17134.8558	35.72	19.30	55.02	74.00	-18.98	peak
		24.67	19.30	43.97	54.00	-10.03	average

- Note: 1. Measurement = Reading Level + Correct Factor.  
 2. If Peak Result complies with AV limit, AV Result is deemed to comply with AV limit.  
 3. Peak: Peak detector.  
 4. Only the worst case emission was recorded, if it complies with the limit, the other emissions deemed to comply with the limit.





**HARMONICS AND SPURIOUS EMISSIONS (MID CHANNEL, VERTICAL)**

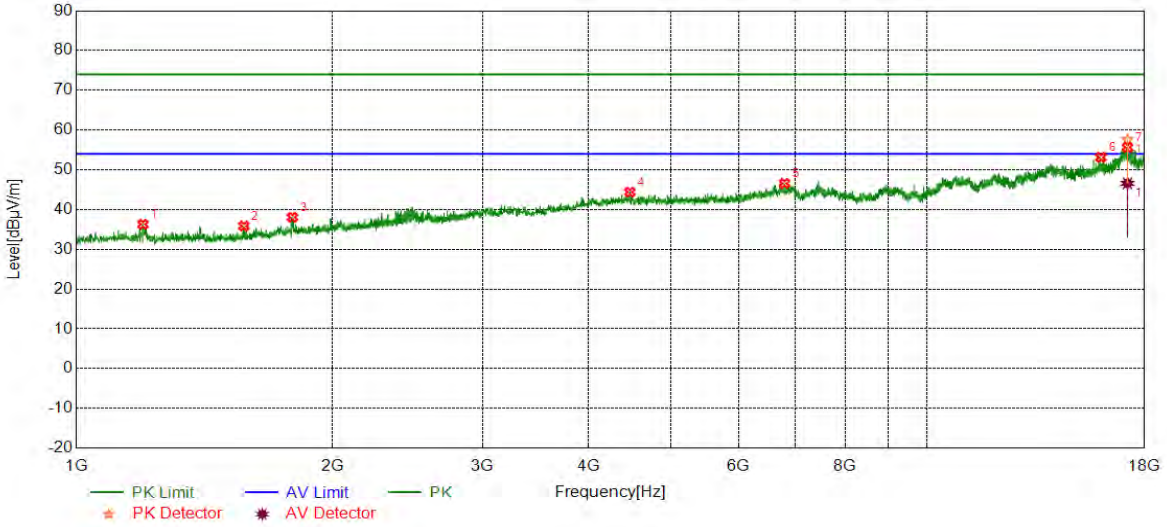

No.	Frequency (MHz)	Reading Level (dBuV/m)	Correct Factor (dB)	Result (dBuV/m)	Limit (dBuV/m)	Margin (dB)	Remark
1	1197.3991	41.83	-5.54	36.29	74.00	-37.71	peak
2	1573.5245	41.20	-5.35	35.85	74.00	-38.15	peak
3	1794.2648	42.00	-3.94	38.06	74.00	-35.94	peak
4	4470.2450	39.32	5.06	44.38	74.00	-29.62	peak
5	6793.1322	38.32	8.26	46.58	74.00	-27.42	peak
6	15992.1654	35.58	17.56	53.14	74.00	-20.86	peak
7	17184.8641	38.02	19.57	57.59	74.00	-16.41	peak
		27.01	19.57	46.58	54.00	-7.42	average

- Note:
1. Measurement = Reading Level + Correct Factor.
  2. If Peak Result complies with AV limit, AV Result is deemed to comply with AV limit.
  3. Peak: Peak detector.
  4. Only the worst case emission was recorded, if it complies with the limit, the other emissions deemed to comply with the limit.



**HARMONICS AND SPURIOUS EMISSIONS (HIGH CHANNEL, HORIZONTAL)**

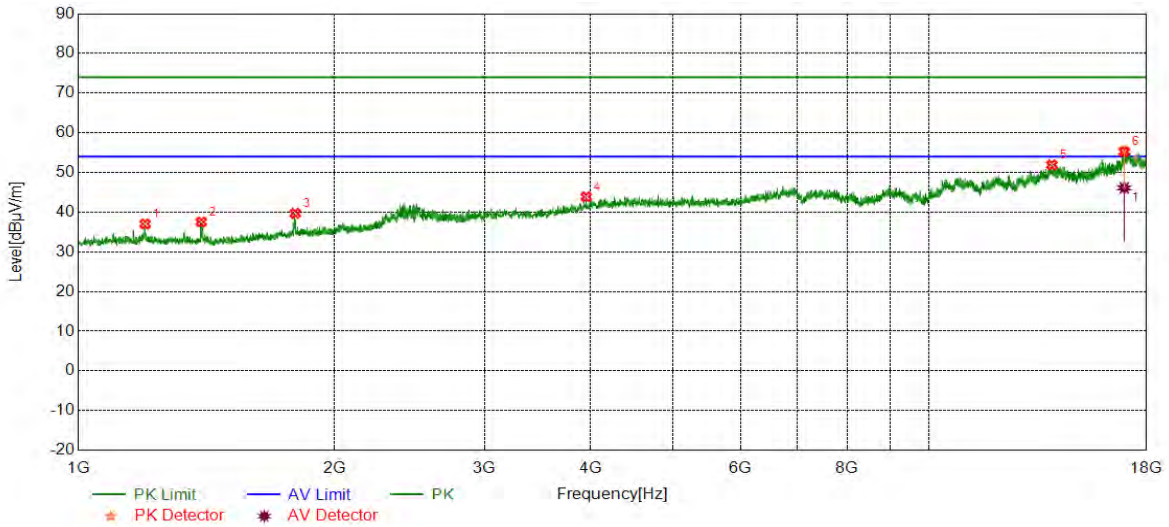

No.	Frequency (MHz)	Reading Level (dBuV/m)	Correct Factor (dB)	Result (dBuV/m)	Limit (dBuV/m)	Margin (dB)	Remark
1	1198.0660	42.56	-5.54	37.02	74.00	-36.98	peak
2	1394.1314	43.19	-5.67	37.52	74.00	-36.48	peak
3	1798.2661	43.59	-3.90	39.69	74.00	-34.31	peak
4	3952.6588	39.42	4.44	43.86	74.00	-30.14	peak
5	13929.3216	35.86	16.05	51.91	74.00	-22.09	peak
6	16942.3237	35.53	20.03	55.56	74.00	-18.44	peak
		26.09	20.03	46.12	54.00	-7.88	average

- Note: 1. Measurement = Reading Level + Correct Factor.  
 2. If Peak Result complies with AV limit, AV Result is deemed to comply with AV limit.  
 3. Peak: Peak detector.  
 4. Only the worst case emission was recorded, if it complies with the limit, the other emissions deemed to comply with the limit.



**HARMONICS AND SPURIOUS EMISSIONS (HIGH CHANNEL, VERTICAL)**

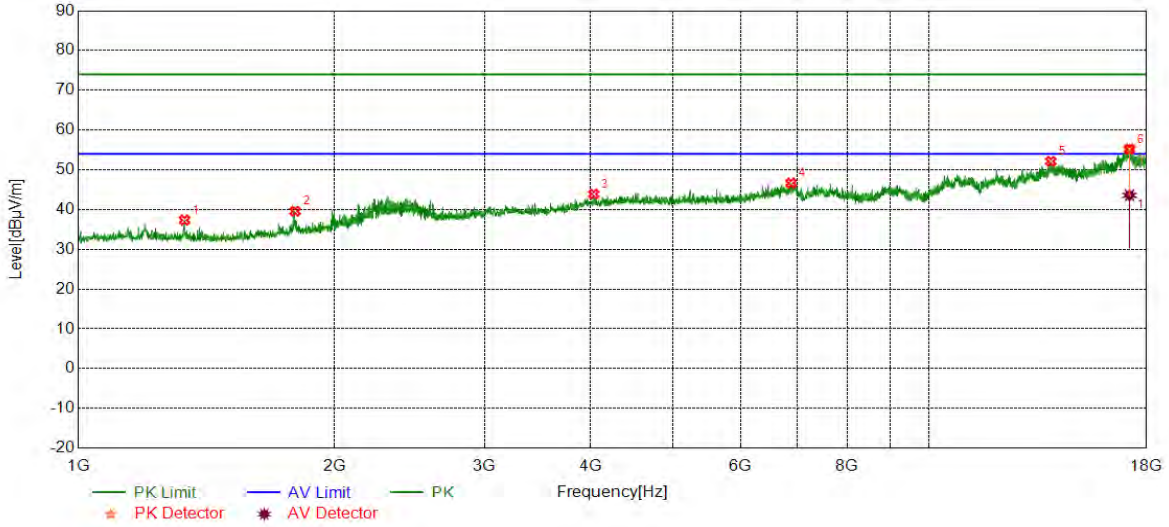

No.	Frequency (MHz)	Reading Level (dBuV/m)	Correct Factor (dB)	Result (dBuV/m)	Limit (dBuV/m)	Margin (dB)	Remark
1	1332.7776	42.97	-5.63	37.34	74.00	-36.66	peak
2	1797.5992	43.48	-3.90	39.58	74.00	-34.42	peak
3	4032.6721	39.48	4.41	43.89	74.00	-30.11	peak
4	6878.1464	38.22	8.45	46.67	74.00	-27.33	peak
5	13891.8153	35.95	16.19	52.14	74.00	-21.86	peak
6	17184.8641	35.50	19.57	55.07	74.00	-18.93	peak
		24.02	19.57	43.59	54.00	-10.41	average

- Note: 1. Measurement = Reading Level + Correct Factor.  
 2. If Peak Result complies with AV limit, AV Result is deemed to comply with AV limit.  
 3. Peak: Peak detector.  
 4. Only the worst case emission was recorded, if it complies with the limit, the other emissions deemed to comply with the limit.

### 9.2.3. 802.11n HT20 MODE

#### HARMONICS AND SPURIOUS EMISSIONS (LOW CHANNEL, HORIZONTAL)

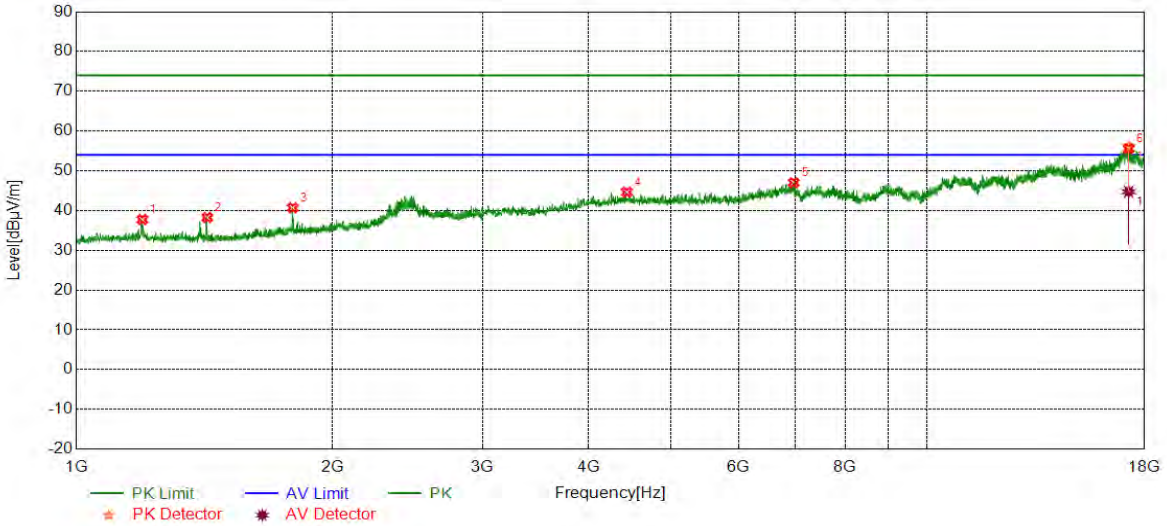

No.	Frequency (MHz)	Reading Level (dBuV/m)	Correct Factor (dB)	Result (dBuV/m)	Limit (dBuV/m)	Margin (dB)	Remark
1	1195.3985	43.29	-5.54	37.75	74.00	-36.25	peak
2	1424.8083	43.96	-5.69	38.27	74.00	-35.73	peak
3	1795.5985	44.60	-3.92	40.68	74.00	-33.32	peak
4	4435.2392	39.47	5.17	44.64	74.00	-29.36	peak
5	6965.6609	38.38	8.64	47.02	74.00	-26.98	peak
6	17239.8733	37.21	18.96	56.17	74.00	-17.83	peak
		25.80	18.96	44.76	54.00	-9.24	average

- Note: 1. Measurement = Reading Level + Correct Factor.  
 2. If Peak Result complies with AV limit, AV Result is deemed to comply with AV limit.  
 3. Peak: Peak detector.  
 4. Only the worst case emission was recorded, if it complies with the limit, the other emissions deemed to comply with the limit.



**HARMONICS AND SPURIOUS EMISSIONS (LOW CHANNEL, VERTICAL)**

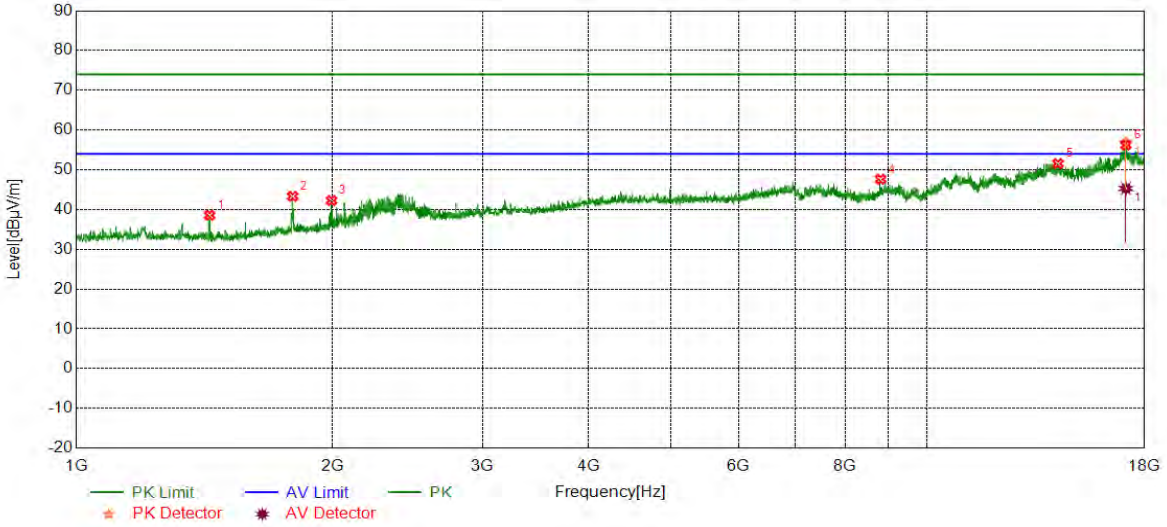

No.	Frequency (MHz)	Reading Level (dBuV/m)	Correct Factor (dB)	Result (dBuV/m)	Limit (dBuV/m)	Margin (dB)	Remark
1	1434.1447	44.31	-5.76	38.55	74.00	-35.45	peak
2	1795.5985	47.24	-3.92	43.32	74.00	-30.68	peak
3	1994.9983	45.31	-3.06	42.25	74.00	-31.75	peak
4	8810.9685	39.01	8.61	47.62	74.00	-26.38	peak
5	14239.3732	35.47	16.09	51.56	74.00	-22.44	peak
6	17112.3521	37.49	19.41	56.90	74.00	-17.10	peak
		25.89	19.41	45.30	54.00	-8.70	average

- Note: 1. Measurement = Reading Level + Correct Factor.  
 2. If Peak Result complies with AV limit, AV Result is deemed to comply with AV limit.  
 3. Peak: Peak detector.  
 4. Only the worst case emission was recorded, if it complies with the limit, the other emissions deemed to comply with the limit.



**HARMONICS AND SPURIOUS EMISSIONS (MID CHANNEL, HORIZONTAL)**

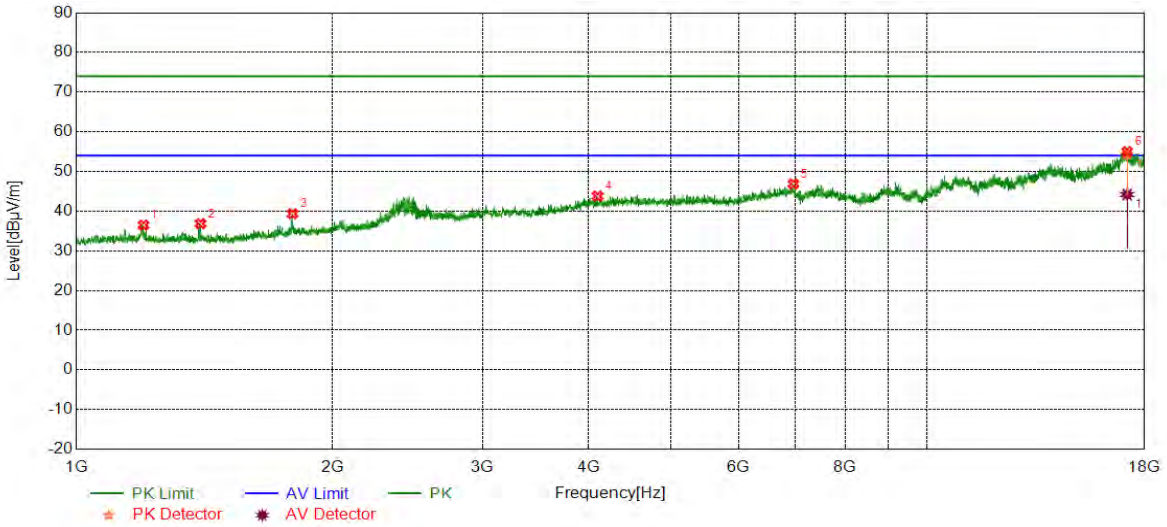

No.	Frequency (MHz)	Reading Level (dBuV/m)	Correct Factor (dB)	Result (dBuV/m)	Limit (dBuV/m)	Margin (dB)	Remark
1	1199.3998	42.03	-5.54	36.49	74.00	-37.51	peak
2	1399.4665	42.40	-5.56	36.84	74.00	-37.16	peak
3	1794.9316	43.27	-3.93	39.34	74.00	-34.66	peak
4	4097.6829	39.43	4.35	43.78	74.00	-30.22	peak
5	6960.6601	38.13	8.75	46.88	74.00	-27.12	peak
6	17167.3612	34.75	19.51	54.26	74.00	-19.74	peak
		24.68	19.51	44.19	54.00	-9.81	average

- Note: 1. Measurement = Reading Level + Correct Factor.  
 2. If Peak Result complies with AV limit, AV Result is deemed to comply with AV limit.  
 3. Peak: Peak detector.  
 4. Only the worst case emission was recorded, if it complies with the limit, the other emissions deemed to comply with the limit.



**HARMONICS AND SPURIOUS EMISSIONS (MID CHANNEL, VERTICAL)**

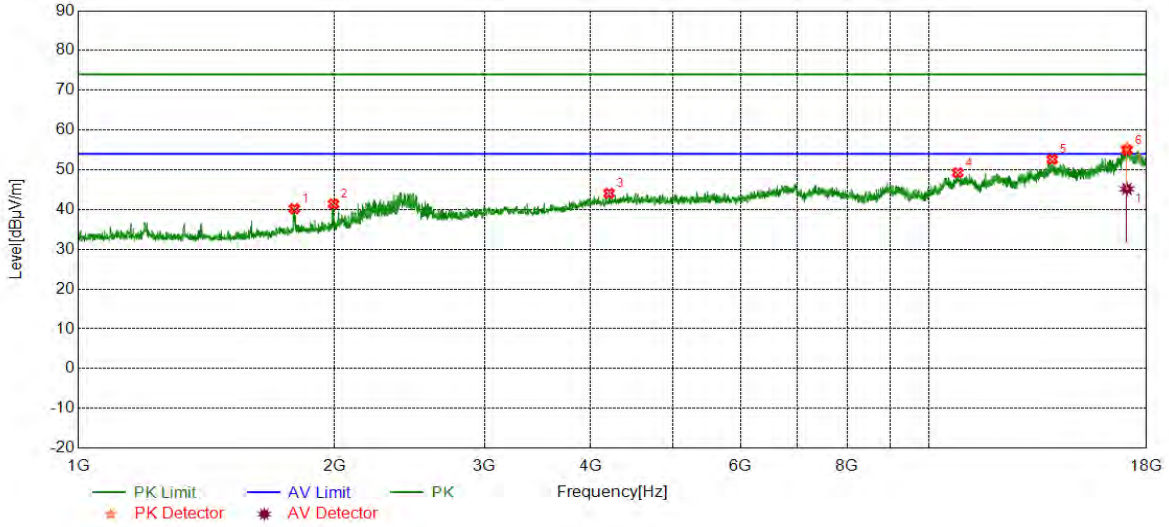

No.	Frequency (MHz)	Reading Level (dBuV/m)	Correct Factor (dB)	Result (dBuV/m)	Limit (dBuV/m)	Margin (dB)	Remark
1	1794.2648	44.15	-3.94	40.21	74.00	-33.79	peak
2	1994.3314	44.47	-3.07	41.40	74.00	-32.60	peak
3	4202.7005	39.59	4.49	44.08	74.00	-29.92	peak
4	10796.2994	36.40	12.87	49.27	74.00	-24.73	peak
5	13941.8236	36.70	15.93	52.63	74.00	-21.37	peak
6	17064.8441	34.99	20.52	55.51	74.00	-18.49	peak
		24.69	20.52	45.21	54.00	-8.79	average

- Note:
1. Measurement = Reading Level + Correct Factor.
  2. If Peak Result complies with AV limit, AV Result is deemed to comply with AV limit.
  3. Peak: Peak detector.
  4. Only the worst case emission was recorded, if it complies with the limit, the other emissions deemed to comply with the limit.



**HARMONICS AND SPURIOUS EMISSIONS (HIGH CHANNEL, HORIZONTAL)**

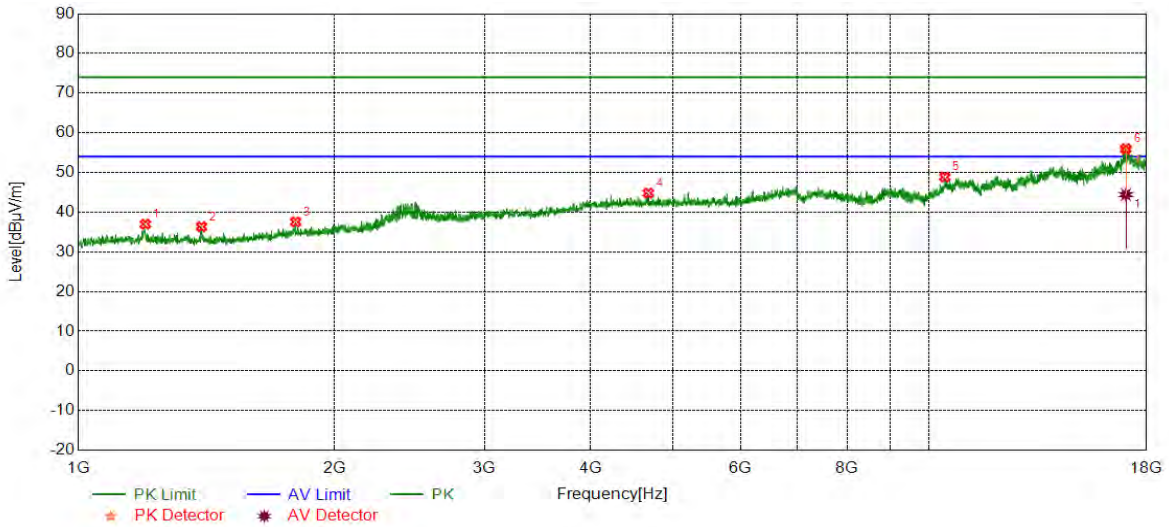

No.	Frequency (MHz)	Reading Level (dBuV/m)	Correct Factor (dB)	Result (dBuV/m)	Limit (dBuV/m)	Margin (dB)	Remark
1	1198.7329	42.50	-5.54	36.96	74.00	-37.04	peak
2	1395.4652	41.99	-5.64	36.35	74.00	-37.65	peak
3	1800.2668	41.43	-3.88	37.55	74.00	-36.45	peak
4	4675.2792	39.60	5.19	44.79	74.00	-29.21	peak
5	10426.2377	36.87	12.00	48.87	74.00	-25.13	peak
6	17017.3362	35.74	19.98	55.72	74.00	-18.28	peak
		24.45	19.98	44.43	54.00	-9.57	average

- Note: 1. Measurement = Reading Level + Correct Factor.  
 2. If Peak Result complies with AV limit, AV Result is deemed to comply with AV limit.  
 3. Peak: Peak detector.  
 4. Only the worst case emission was recorded, if it complies with the limit, the other emissions deemed to comply with the limit.





**HARMONICS AND SPURIOUS EMISSIONS (HIGH CHANNEL, VERTICAL)**

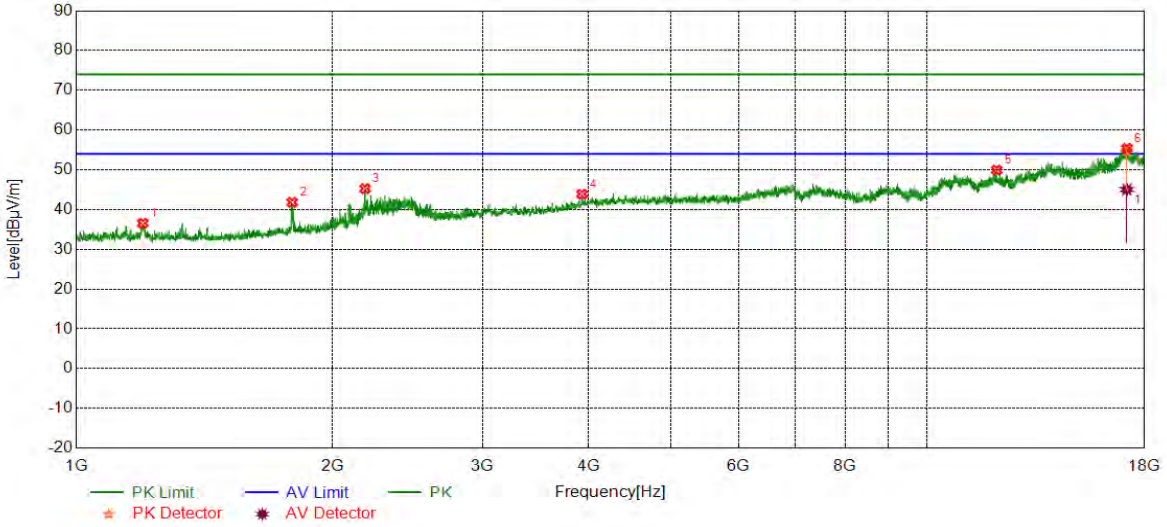

No.	Frequency (MHz)	Reading Level (dBuV/m)	Correct Factor (dB)	Result (dBuV/m)	Limit (dBuV/m)	Margin (dB)	Remark
1	1196.7322	42.11	-5.54	36.57	74.00	-37.43	peak
2	1792.9310	45.76	-3.95	41.81	74.00	-32.19	peak
3	2184.3948	47.61	-2.35	45.26	74.00	-28.74	peak
4	3927.6546	39.59	4.30	43.89	74.00	-30.11	peak
5	12064.0107	36.29	13.65	49.94	74.00	-24.06	peak
6	17154.8591	35.05	19.74	54.79	74.00	-19.21	peak
		20.30	19.74	40.04	54.00	-13.96	average

- Note:
1. Measurement = Reading Level + Correct Factor.
  2. If Peak Result complies with AV limit, AV Result is deemed to comply with AV limit.
  3. Peak: Peak detector.
  4. Only the worst case emission was recorded, if it complies with the limit, the other emissions deemed to comply with the limit.



### 9.2.4. 802.11n HT40 MODE

#### HARMONICS AND SPURIOUS EMISSIONS (LOW CHANNEL, HORIZONTAL)

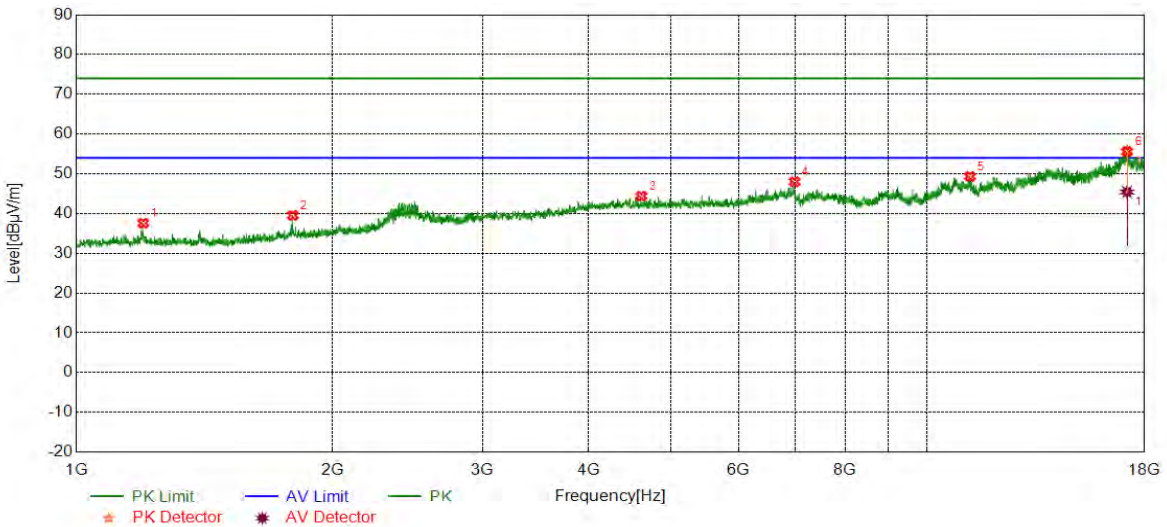

No.	Frequency (MHz)	Reading Level (dBuV/m)	Correct Factor (dB)	Result (dBuV/m)	Limit (dBuV/m)	Margin (dB)	Remark
1	1198.7329	43.12	-5.54	37.58	74.00	-36.42	peak
2	1796.2654	43.46	-3.92	39.54	74.00	-34.46	peak
3	4612.7688	39.33	5.06	44.39	74.00	-29.61	peak
4	6980.6634	39.43	8.57	48.00	74.00	-26.00	peak
6	17162.3604	36.07	19.67	55.74	74.00	-18.26	peak
		25.76	19.67	45.43	54.00	-8.57	average

- Note: 1. Measurement = Reading Level + Correct Factor.  
 2. If Peak Result complies with AV limit, AV Result is deemed to comply with AV limit.  
 3. Peak: Peak detector.  
 4. Only the worst case emission was recorded, if it complies with the limit, the other emissions deemed to comply with the limit.



**HARMONICS AND SPURIOUS EMISSIONS (LOW CHANNEL, VERTICAL)**

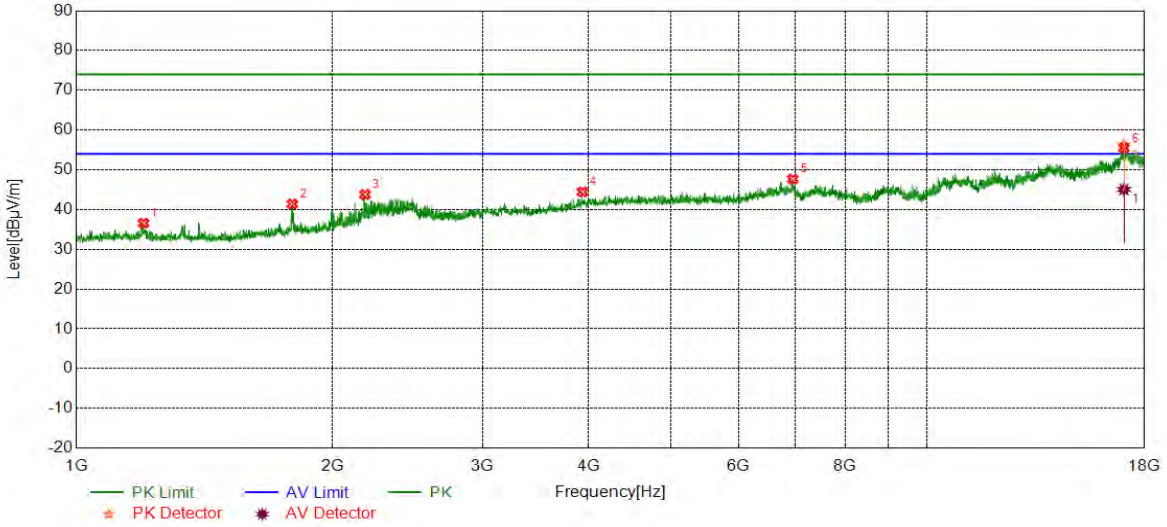

No.	Frequency (MHz)	Reading Level (dBuV/m)	Correct Factor (dB)	Result (dBuV/m)	Limit (dBuV/m)	Margin (dB)	Remark
1	1199.3998	42.10	-5.54	36.56	74.00	-37.44	peak
2	1793.5979	45.34	-3.95	41.39	74.00	-32.61	peak
3	2183.7279	46.11	-2.34	43.77	74.00	-30.23	peak
4	3932.6554	39.97	4.48	44.45	74.00	-29.55	peak
5	6948.1580	38.89	8.78	47.67	74.00	-26.33	peak
6	17022.3371	36.08	20.17	56.25	74.00	-17.75	peak
		24.89	20.17	45.06	54.00	-8.94	average

Note: 1. Measurement = Reading Level + Correct Factor.  
 2. If Peak Result complies with AV limit, AV Result is deemed to comply with AV limit.  
 3. Peak: Peak detector.  
 4. Only the worst case emission was recorded, if it complies with the limit, the other emissions deemed to comply with the limit.



**HARMONICS AND SPURIOUS EMISSIONS (MID CHANNEL, HORIZONTAL)**

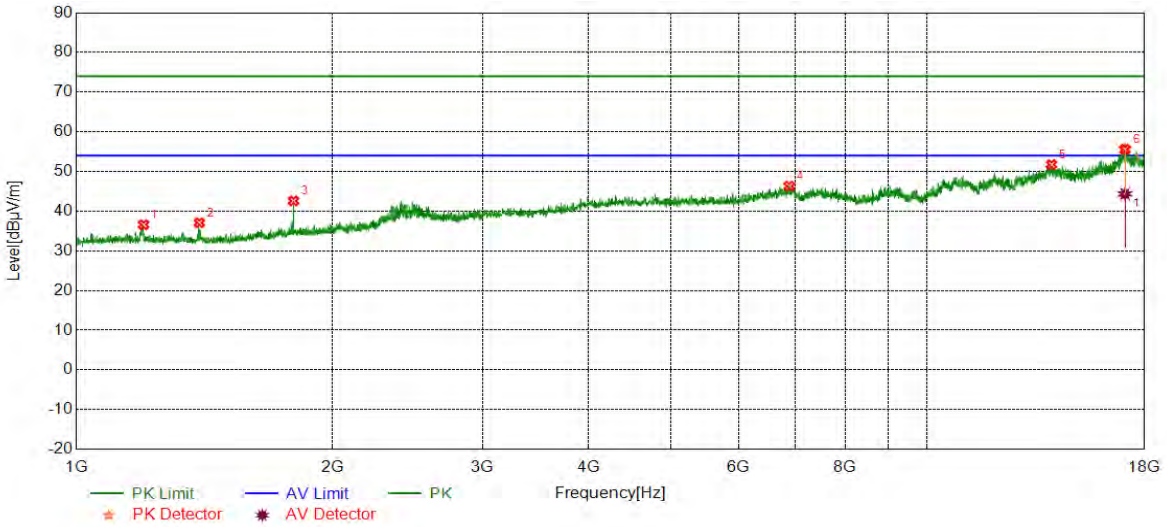

No.	Frequency (MHz)	Reading Level (dBuV/m)	Correct Factor (dB)	Result (dBuV/m)	Limit (dBuV/m)	Margin (dB)	Remark
1	1199.3998	42.12	-5.54	36.58	74.00	-37.42	peak
2	1394.7983	42.75	-5.66	37.09	74.00	-36.91	peak
3	1799.5999	46.46	-3.88	42.58	74.00	-31.42	peak
4	6883.1472	37.86	8.43	46.29	74.00	-27.71	peak
5	13991.8320	35.65	16.11	51.76	74.00	-22.24	peak
6	17067.3446	35.17	20.52	55.69	74.00	-18.31	peak
		23.83	20.52	44.35	54.00	-9.65	average

- Note: 1. Measurement = Reading Level + Correct Factor.  
 2. If Peak Result complies with AV limit, AV Result is deemed to comply with AV limit.  
 3. Peak: Peak detector.  
 4. Only the worst case emission was recorded, if it complies with the limit, the other emissions deemed to comply with the limit.



**HARMONICS AND SPURIOUS EMISSIONS (MID CHANNEL, VERTICAL)**

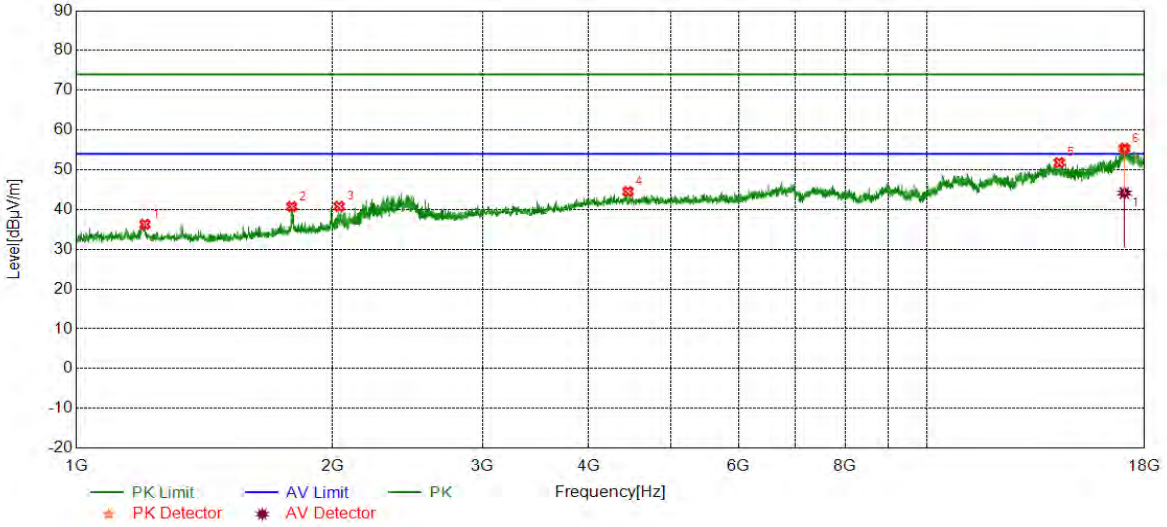

No.	Frequency (MHz)	Reading Level (dBuV/m)	Correct Factor (dB)	Result (dBuV/m)	Limit (dBuV/m)	Margin (dB)	Remark
1	1204.0680	41.85	-5.57	36.28	74.00	-37.72	peak
2	1791.5972	44.71	-3.97	40.74	74.00	-33.26	peak
3	2036.3454	43.40	-2.60	40.80	74.00	-33.20	peak
4	4447.7413	39.42	5.12	44.54	74.00	-29.46	peak
5	14289.3816	36.10	15.73	51.83	74.00	-22.17	peak
6	17044.8408	35.3	19.86	55.16	74.00	-18.84	peak
		24.29	19.86	44.15	54.00	-9.85	average

- Note: 1. Measurement = Reading Level + Correct Factor.  
 2. If Peak Result complies with AV limit, AV Result is deemed to comply with AV limit.  
 3. Peak: Peak detector.  
 4. Only the worst case emission was recorded, if it complies with the limit, the other emissions deemed to comply with the limit.



**HARMONICS AND SPURIOUS EMISSIONS (HIGH CHANNEL, HORIZONTAL)**

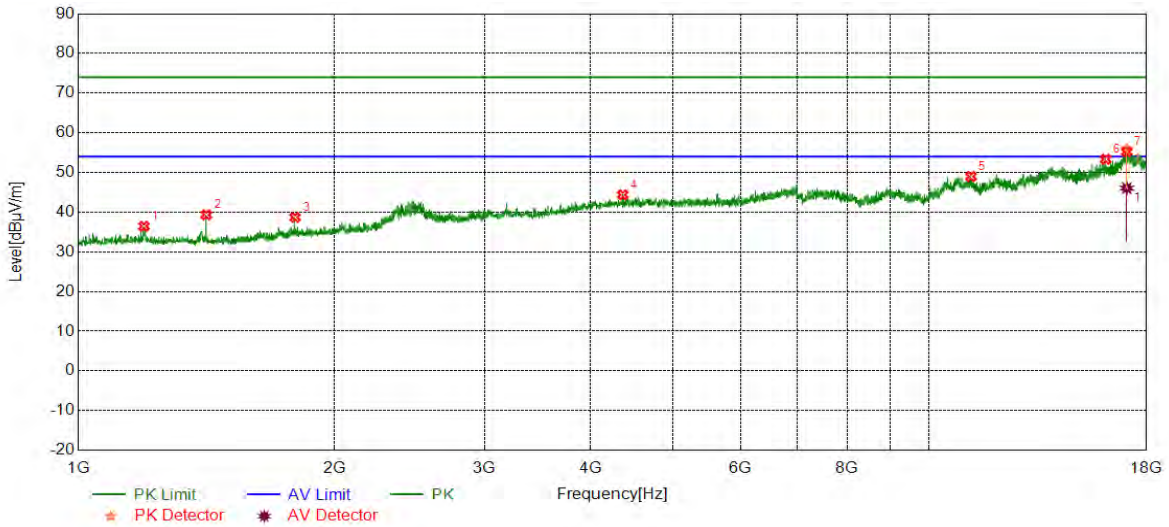

No.	Frequency (MHz)	Reading Level (dBuV/m)	Correct Factor (dB)	Result (dBuV/m)	Limit (dBuV/m)	Margin (dB)	Remark
1	1194.0647	41.98	-5.55	36.43	74.00	-37.57	peak
2	1414.1380	45.03	-5.70	39.33	74.00	-34.67	peak
3	1797.5992	42.60	-3.90	38.70	74.00	-35.30	peak
4	4362.7271	39.54	4.84	44.38	74.00	-29.62	peak
5	11193.8656	36.39	12.59	48.98	74.00	-25.02	peak
6	16114.6858	36.14	17.20	53.34	74.00	-20.66	peak
7	17059.8433	35.43	20.52	55.95	74.00	-18.05	peak
		25.54	20.52	46.06	54.00	-7.94	average

- Note: 1. Measurement = Reading Level + Correct Factor.  
 2. If Peak Result complies with AV limit, AV Result is deemed to comply with AV limit.  
 3. Peak: Peak detector.  
 4. Only the worst case emission was recorded, if it complies with the limit, the other emissions deemed to comply with the limit.



**HARMONICS AND SPURIOUS EMISSIONS (HIGH CHANNEL, VERTICAL)**

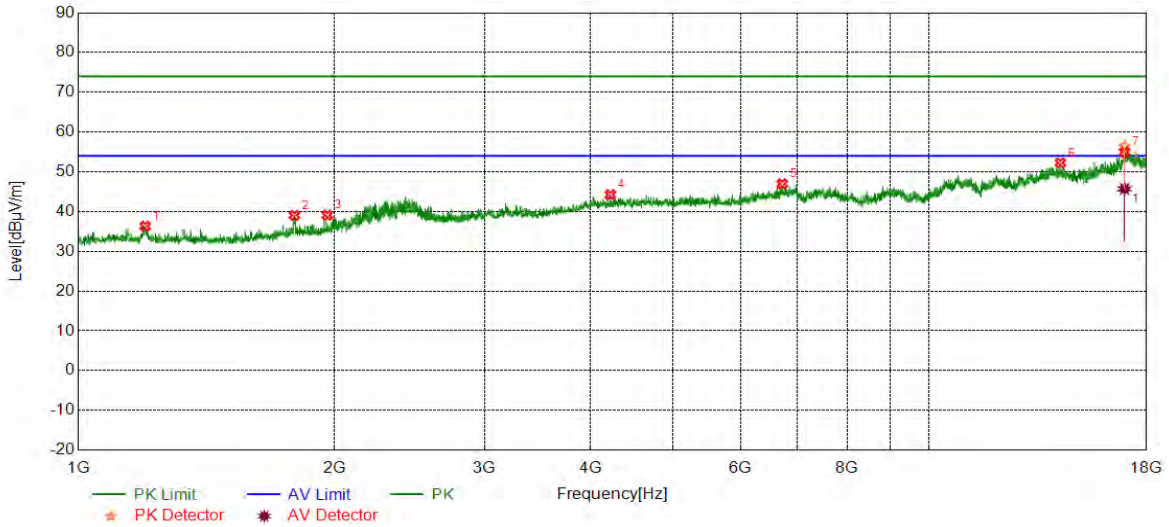

No.	Frequency (MHz)	Reading Level (dBuV/m)	Correct Factor (dB)	Result (dBuV/m)	Limit (dBuV/m)	Margin (dB)	Remark
1	1198.0660	41.87	-5.54	36.33	74.00	-37.67	peak
2	1794.2648	42.99	-3.94	39.05	74.00	-34.95	peak
3	1960.9870	42.32	-3.21	39.11	74.00	-34.89	peak
4	4217.7030	39.56	4.66	44.22	74.00	-29.78	peak
5	6715.6193	38.47	8.51	46.98	74.00	-27.02	peak
6	14254.3757	36.44	15.81	52.25	74.00	-21.75	peak
7	16954.8258	36.39	20.03	56.42	74.00	-17.58	peak
		25.68	20.03	45.71	54.00	-8.29	average

- Note: 1. Measurement = Reading Level + Correct Factor.  
 2. If Peak Result complies with AV limit, AV Result is deemed to comply with AV limit.  
 3. Peak: Peak detector.  
 4. Only the worst case emission was recorded, if it complies with the limit, the other emissions deemed to comply with the limit.

### 9.3. SPURIOUS EMISSIONS (18~26GHz)

#### 9.3.1. 802.11b MODE

#### SPURIOUS EMISSIONS (HIGH CHANNEL, WORST-CASE CONFIGURATION, HORIZONTAL)

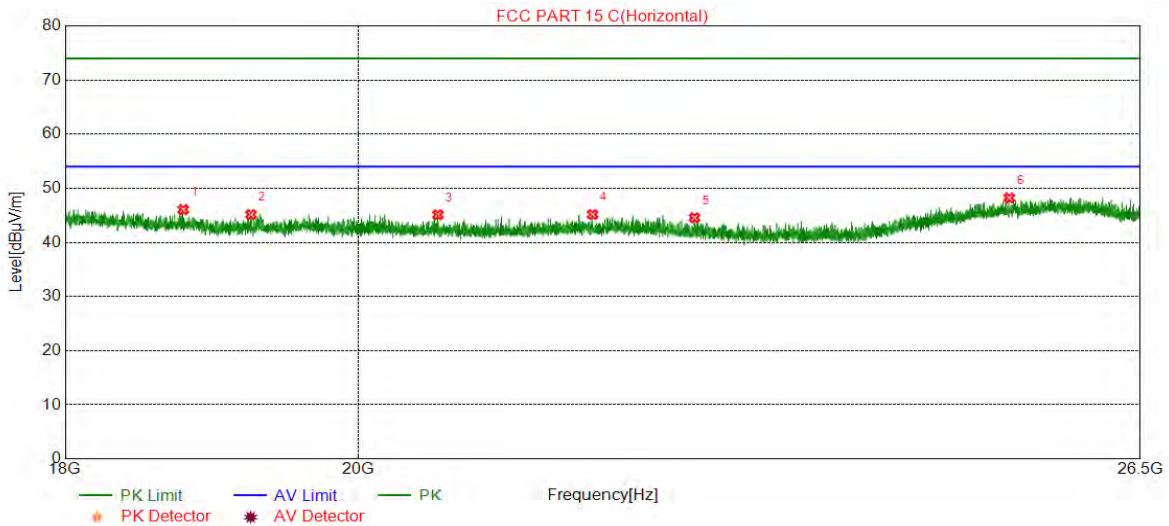

No.	Frequency (MHz)	Reading Level (dBuV/m)	Correct Factor (dB)	Result (dBuV/m)	Limit (dBuV/m)	Margin (dB)	Remark
1	18781.2281	49.83	-3.78	46.05	74.00	-27.95	peak
2	19244.5245	48.86	-3.71	45.15	74.00	-28.85	peak
3	20583.4083	48.41	-3.31	45.10	74.00	-28.90	peak
4	21761.6262	48.25	-3.10	45.15	74.00	-28.85	peak
5	22574.3074	48.10	-3.55	44.55	74.00	-29.45	peak
6	25281.8282	48.47	-0.26	48.21	74.00	-25.79	peak

- Note: 1. Measurement = Reading Level + Correct Factor.  
 2. If Peak Result complies with AV limit, AV Result is deemed to comply with AV limit.  
 3. Peak: Peak detector.  
 4. Only the worst case emission was recorded, if it complies with the limit, the other emissions deemed to comply with the limit.





**SPURIOUS EMISSIONS (HIGH CHANNEL, WORST-CASE CONFIGURATION, VERTICAL)**

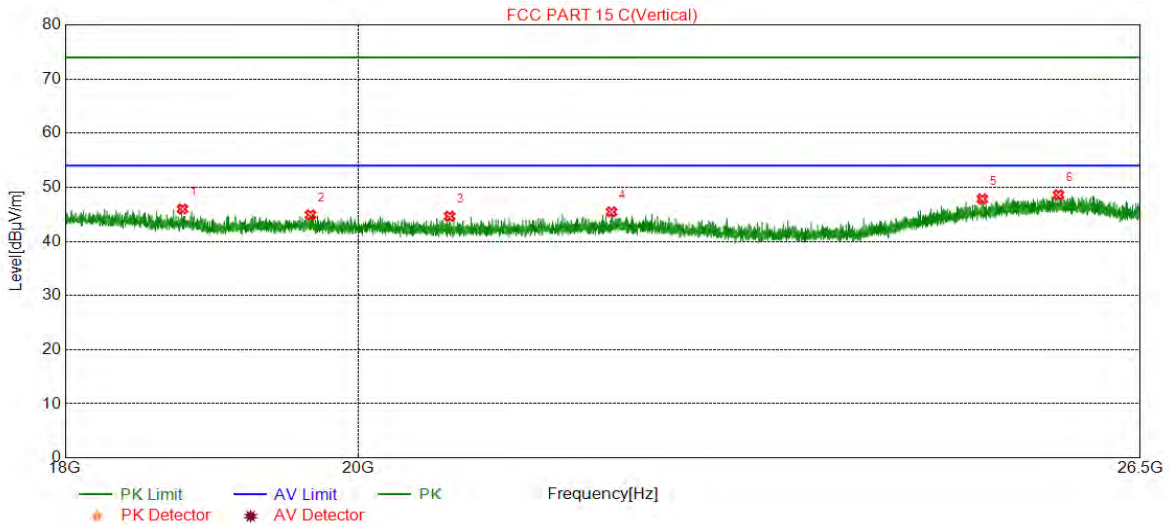

No.	Frequency (MHz)	Reading Level (dBuV/m)	Correct Factor (dB)	Result (dBuV/m)	Limit (dBuV/m)	Margin (dB)	Remark
1	18775.2775	49.75	-3.77	45.98	74.00	-28.02	peak
2	19661.0661	48.19	-3.30	44.89	74.00	-29.11	peak
3	20670.1170	47.99	-3.34	44.65	74.00	-29.35	peak
4	21910.3910	48.41	-2.97	45.44	74.00	-28.56	peak
5	25037.8538	48.42	-0.58	47.84	74.00	-26.16	peak
6	25734.0734	48.05	0.54	48.59	74.00	-25.41	peak

- Note: 1. Measurement = Reading Level + Correct Factor.  
 2. If Peak Result complies with AV limit, AV Result is deemed to comply with AV limit.  
 3. Peak: Peak detector.  
 4. Only the worst case emission was recorded, if it complies with the limit, the other emissions deemed to comply with the limit.

Note: All the test modes have been tested, only the worst data record in the report.

## 9.4. SPURIOUS EMISSIONS (0.03 ~ 1 GHz)

### 9.4.1. 802.11b MODE

#### SPURIOUS EMISSIONS (MID CHANNEL, WORST-CASE CONFIGURATION, HORIZONTAL)

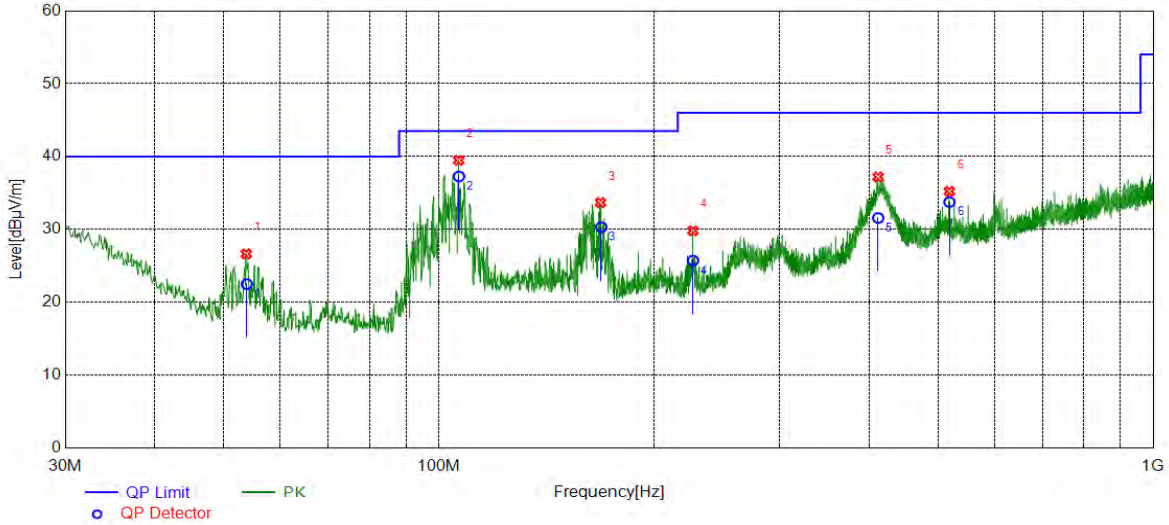

No.	Frequency (MHz)	Reading Level (dBuV/m)	Correct Factor (dB)	Result (dBuV/m)	Limit (dBuV/m)	Margin (dB)	Remark
1	53.8600	8.16	14.34	22.50	40.00	-17.50	QP
2	106.6956	19.27	18.00	37.27	43.50	-6.23	QP
3	168.7989	11.99	18.33	30.32	43.50	-13.18	QP
4	226.8834	7.71	18.02	25.73	46.00	-20.27	QP
5	412.0517	8.34	23.23	31.57	46.00	-14.43	QP
6	518.3946	7.88	25.88	33.76	46.00	-12.24	QP

- Note: 1. Result Level = Read Level + Correct Factor.  
 2. If Peak Result complies with QP limit, QP Result is deemed to comply with QP limit.  
 3. Test setup: RBW: 120 kHz, VBW: 300 kHz, Sweep time: auto.

**SPURIOUS EMISSIONS (MID CHANNEL, WORST-CASE CONFIGURATION, VERTICAL)**

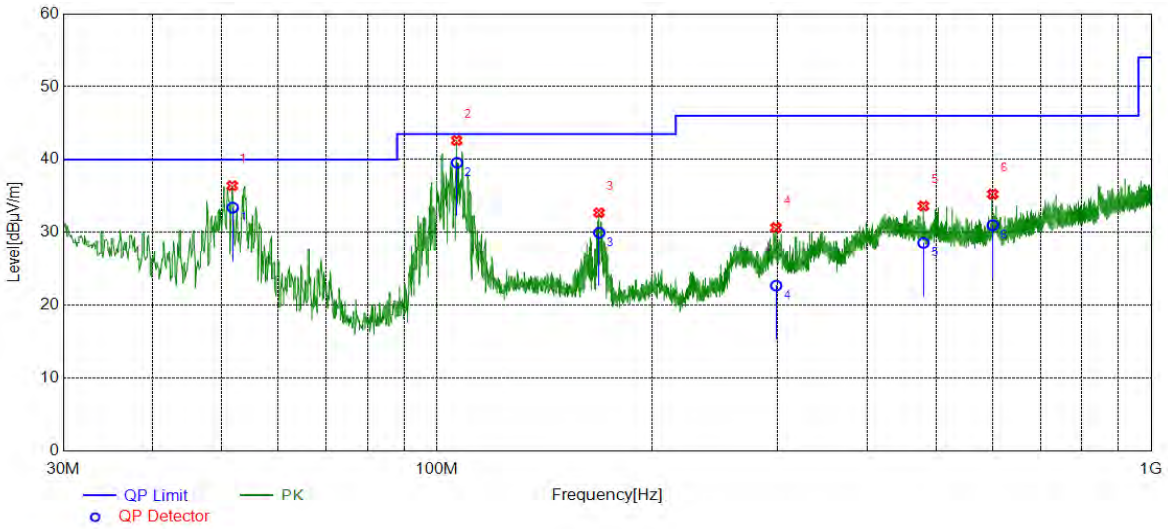

No.	Frequency (MHz)	Reading Level (dBuV/m)	Correct Factor (dB)	Result (dBuV/m)	Limit (dBuV/m)	Margin (dB)	Remark
1	51.8011	18.96	14.45	33.41	40.00	-6.59	QP
2	106.7115	21.57	18.00	39.57	43.50	-3.93	QP
3	168.8020	11.63	18.33	29.96	43.50	-13.54	QP
4	298.5112	2.27	20.43	22.70	46.00	-23.30	QP
5	479.9991	3.40	25.15	28.55	46.00	-17.45	QP
6	600.0203	4.47	26.53	31.00	46.00	-15.00	QP

Note: 1. Result Level = Read Level + Correct Factor.  
 2. If Peak Result complies with QP limit, QP Result is deemed to comply with QP limit.  
 3. Test setup: RBW: 120 kHz, VBW: 300 kHz, Sweep time: auto.

Note: All the test modes have been tested, only the worst data record in the report.

## 9.5. SPURIOUS EMISSIONS BELOW 30M

### 9.5.1. 802.11b MODE

#### SPURIOUS EMISSIONS (MID CHANNEL, WORST-CASE CONFIGURATION, Face-on)

##### 0.09~ 150kHz

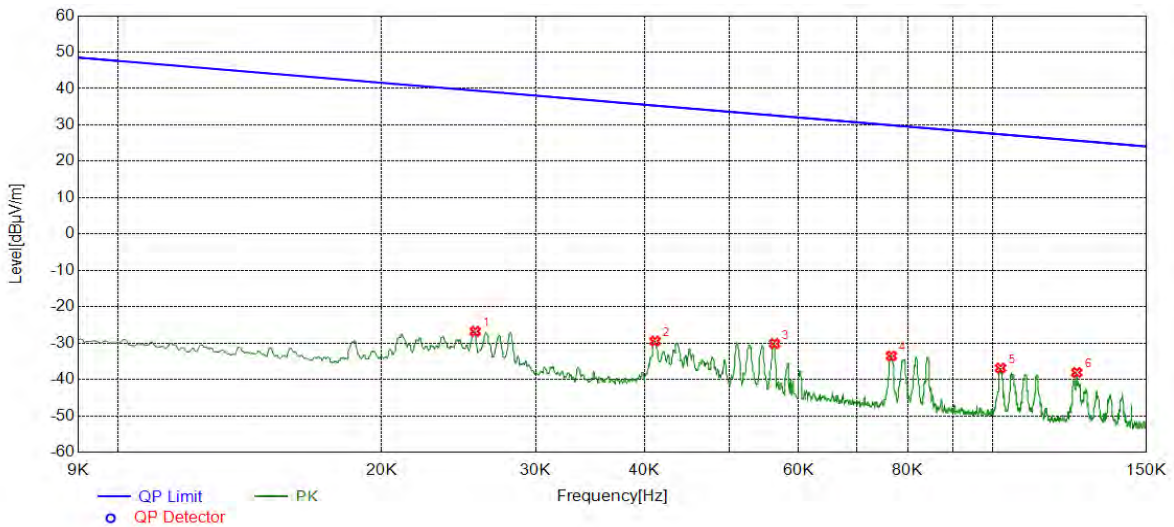

No.	Frequency (MHz)	Reading Level (dBuV/m)	Correct Factor (dB)	Result (dBuV/m)	Limit (dBuV/m)	Margin (dB)	Remark
1	0.0256	34.22	-61.00	-26.78	39.45	-66.23	peak
2	0.0411	31.65	-61.10	-29.45	35.33	-64.78	peak
3	0.0563	31.13	-61.26	-30.13	32.60	-62.73	peak
4	0.0766	27.97	-61.51	-33.54	29.92	-63.46	peak
5	0.1021	24.00	-60.88	-36.88	27.42	-64.30	peak
6	0.1248	23.06	-61.15	-38.09	25.69	-63.78	peak

- Note: 1. Measurement = Reading Level + Correct Factor.  
 2. If Peak Result complies with AV and QP limit, AV and QP Result are deemed to comply with AV limit.  
 3. All 3 polarizations(Horizontal, Face-on and Face-off) of the loop antenna had been tested, but only the worst data recorded in the report



**150kHz ~ 490kHz**

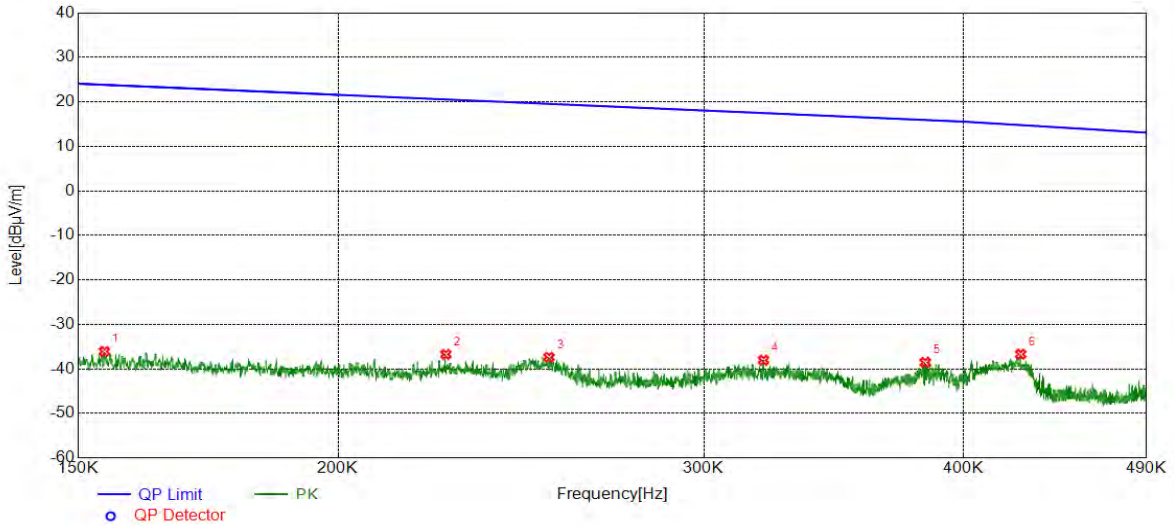

No.	Frequency (MHz)	Reading Level (dBuV/m)	Correct Factor (dB)	Result (dBuV/m)	Limit (dBuV/m)	Margin (dB)	Remark
1	0.1544	25.37	-61.43	-36.06	23.83	-59.89	peak
2	0.2254	24.34	-61.07	-36.73	20.54	-57.27	peak
3	0.2527	23.57	-60.94	-37.37	19.55	-56.92	peak
4	0.3205	22.84	-60.88	-38.04	17.49	-55.53	peak
5	0.3834	22.29	-60.83	-38.54	15.93	-54.47	peak
6	0.4262	24.09	-60.79	-36.70	14.79	-51.49	peak

- Note:
1. Measurement = Reading Level + Correct Factor.
  2. If Peak Result complies with AV and QP limit, AV and QP Result are deemed to comply with AV limit.
  3. All 3 polarizations(Horizontal, Face-on and Face-off) of the loop antenna had been tested, but only the worst data recorded in the report



**490kHz ~ 30MHz**

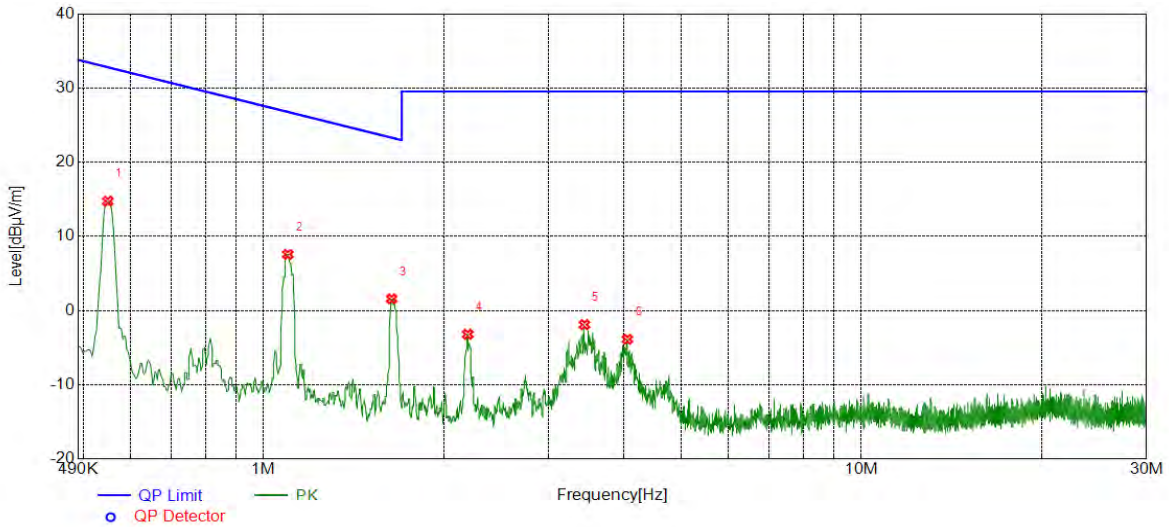

No.	Frequency (MHz)	Reading Level (dBuV/m)	Correct Factor (dB)	Result (dBuV/m)	Limit (dBuV/m)	Margin (dB)	Remark
1	0.5490	35.49	-20.74	14.75	32.81	-18.06	peak
2	1.0980	28.05	-20.47	7.58	26.80	-19.22	peak
3	1.6381	21.98	-20.39	1.59	23.32	-21.73	peak
4	2.1958	17.19	-20.38	-3.19	29.54	-32.73	peak
5	3.4413	18.50	-20.40	-1.90	29.54	-31.44	peak
6	4.0611	16.30	-20.17	-3.87	29.54	-33.41	peak

- Note: 1. Measurement = Reading Level + Correct Factor.  
 2. If Peak Result complies with AV and QP limit, AV and QP Result are deemed to comply with AV limit.  
 3. All 3 polarizations(Horizontal, Face-on and Face-off) of the loop antenna had been tested, but only the worst data recorded in the report

Note: All the test modes have been tested, only the worst data record in the report.

## 10. AC POWER LINE CONDUCTED EMISSIONS

### LIMITS

Please refer to CFR 47 FCC §15.207 (a)

FREQUENCY (MHz)	Quasi-peak	Average
0.15 -0.5	66 - 56 *	56 - 46 *
0.50 -5.0	56.00	46.00
5.0 -30.0	60.00	50.00

### TEST SETUP AND PROCEDURE

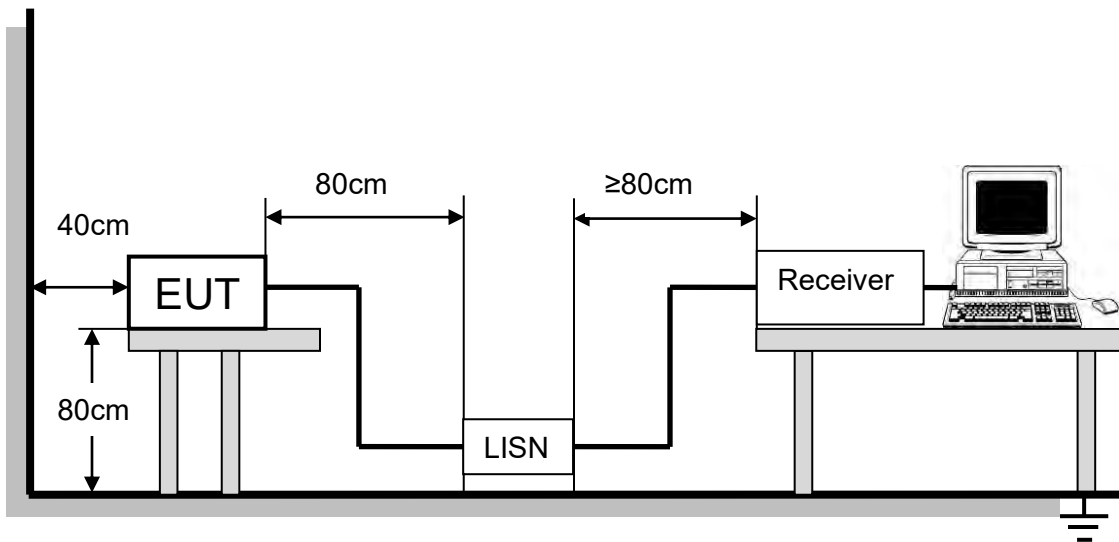

The EUT is put on a table of non-conducting material that is 80cm high. The vertical conducting wall of shielding is located 40cm to the rear of the EUT. The power line of the EUT is connected to the AC mains through a Artificial Mains Network (A.M.N.). A EMI Measurement Receiver (R&S Test Receiver ESR3) is used to test the emissions from both sides of AC line. According to the requirements in Section 7 and 13 of ANSI C63.10-2013. Conducted emissions from the EUT measured in the frequency range between 0.15 MHz and 30MHz using CISPR Quasi-Peak and average detector mode. The bandwidth of EMI test receiver is set at 9kHz.

The arrangement of the equipment is installed to meet the standards and operating in a manner, which tends to maximize its emission characteristics in a normal application.

### TEST ENVIRONMENT

Temperature	20°C	Relative Humidity	56%
Atmosphere Pressure	101kPa	Test Voltage	DC 12V



**TEST RESULTS**

**10.1. 802.11b MODE**

**LINE N RESULTS (HIGH CHANNEL, WORST-CASE CONFIGURATION)**

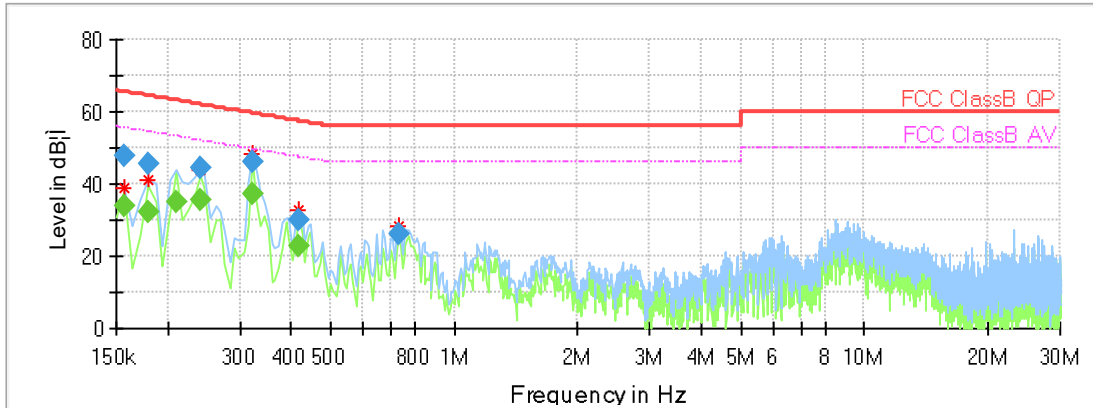

**Final Result**

Frequency (MHz)	QuasiPeak (dB $\mu$ V)	Average (dB $\mu$ V)	Limit (dB $\mu$ V)	Margin (dB)	Meas. Time (ms)	Bandwidth (kHz)	Line	Filter	Corr. (dB)
0.157463	---	33.99	55.60	21.60	1000.0	9.000	N	OFF	9.6
0.157463	47.96	---	65.60	17.63	1000.0	9.000	N	OFF	9.6
0.179850	---	32.02	54.49	22.47	1000.0	9.000	N	OFF	9.6
0.179850	45.76	---	64.49	18.74	1000.0	9.000	N	OFF	9.6
0.209700	---	35.13	53.22	18.09	1000.0	9.000	N	OFF	9.6
0.239550	44.22	---	62.11	17.89	1000.0	9.000	N	OFF	9.6
0.239550	---	35.72	52.11	16.40	1000.0	9.000	N	OFF	9.6
0.321638	46.18	---	59.66	13.49	1000.0	9.000	N	OFF	9.6
0.321638	---	37.16	49.66	12.50	1000.0	9.000	N	OFF	9.6
0.418650	29.86	---	57.48	27.61	1000.0	9.000	N	OFF	9.6
0.418650	---	23.02	47.48	24.45	1000.0	9.000	N	OFF	9.6
0.732075	26.34	---	56.00	29.66	1000.0	9.000	N	OFF	9.6





**LINE L RESULTS (HIGH CHANNEL, WORST-CASE CONFIGURATION)**

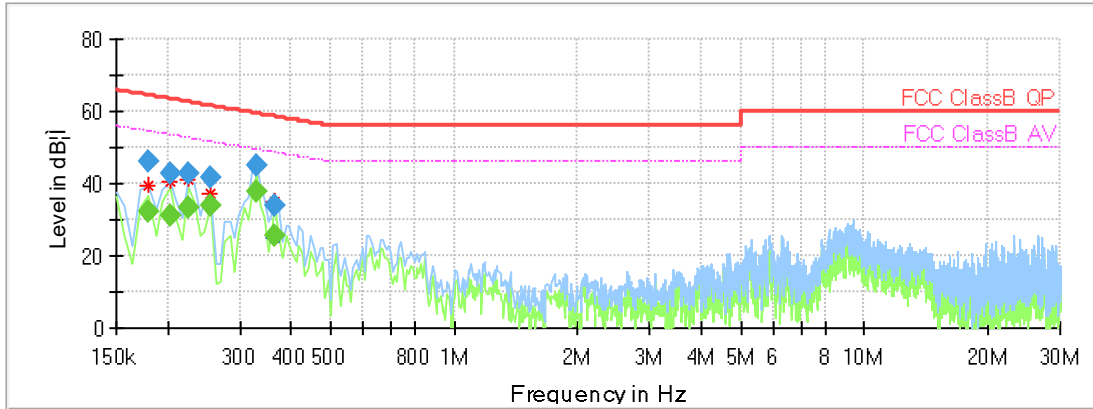

**Final Result**

Frequency (MHz)	QuasiPeak (dBµV)	Average (dBµV)	Limit (dBµV)	Margin (dB)	Meas. Time (ms)	Bandwidth (kHz)	Line	Filter	Corr. (dB)
0.179850	---	31.97	54.49	22.52	1000.0	9.000	L1	OFF	9.6
0.179850	46.36	---	64.49	18.13	1000.0	9.000	L1	OFF	9.6
0.202238	---	31.13	53.52	22.39	1000.0	9.000	L1	OFF	9.6
0.202238	42.64	---	63.52	20.88	1000.0	9.000	L1	OFF	9.6
0.224625	---	33.58	52.65	19.06	1000.0	9.000	L1	OFF	9.6
0.224625	42.91	---	62.65	19.73	1000.0	9.000	L1	OFF	9.6
0.254475	41.55	---	61.61	20.06	1000.0	9.000	L1	OFF	9.6
0.254475	---	34.09	51.61	17.52	1000.0	9.000	L1	OFF	9.6
0.329100	45.27	---	59.47	14.21	1000.0	9.000	L1	OFF	9.6
0.329100	---	37.78	49.47	11.70	1000.0	9.000	L1	OFF	9.6
0.366413	---	25.28	48.58	23.30	1000.0	9.000	L1	OFF	9.6
0.366413	34.11	---	58.58	24.47	1000.0	9.000	L1	OFF	9.6

Note: All the test modes have been tested, only the worst data record in the report.



## 11. ANTENNA REQUIREMENTS

### APPLICABLE REQUIREMENTS

Please refer to FCC §15.203

An intentional radiator shall be designed to ensure that no antenna other than that furnished by the responsible party shall be used with the device. The use of a permanently attached antenna or of an antenna that uses a unique coupling to the intentional radiator shall be considered sufficient to comply with the provisions of this section. The manufacturer may design the unit so that a broken antenna can be replaced by the user, but the use of a standard antenna jack or electrical connector is prohibited.

Please refer to FCC §15.247(b)(4)

The conducted output power limit specified in paragraph (b) of this section is based on the use of antennas with directional gains that do not exceed 6 dBi. Except as shown in paragraph (c) of this section, if transmitting antennas of directional gain greater than 6 dBi are used, the conducted output power from the intentional radiator shall be reduced below the stated values in paragraphs (b)(1), (b)(2), and (b)(3) of this section, as appropriate, by the amount in dB that the directional gain of the antenna exceeds 6 dBi.

### RESULTS

Complies

**END OF REPORT**