



FCC Part 15E Test Report

FCC ID: 2AL7VRLC-410W

Product Name:	WiFi IP Camera
Trademark:	
Model Name :	RLC-410W
Prepared For :	Shenzhen Reo-link Digital Technology Co., Ltd
Address :	11th floor, Building C, Unisplendour Information Harbour, North High-Tech Zone, Nanshan District, Shenzhen, China, 518057
Prepared By :	Shenzhen BCTC Testing Co., Ltd.
Address :	BCTC Building & 1-2F, East of B Building, Pengzhou Industrial, Fuyuan 1st Road, Qiaotou Community, Fuyong Street, Bao'an District, Shenzhen, China
Test Date:	Jun. 27, 2019 – Aug. 23, 2019
Date of Report :	Aug. 23, 2019
Report No.:	BCTC-FY190603611E



TEST RESULT CERTIFICATION

Applicant's name : Shenzhen Reo-link Digital Technology Co., Ltd
Address : 11th floor, Building C, Unisplendour Information Harbour,
North High-Tech Zone, Nanshan District, Shenzhen, China,
518057

Manufacture's Name..... : SHENZHEN BAICHUAN SECURITY TECHNOLOGY
CO.,LTD
Address : 2-4th Floor, Building 2, YuanLing Industrial Park, ShangWu,
Shiyan Street, Bao'an District, Shenzhen, China

Product description

Product name : WiFi IP Camera

Trademark : 

Model and/or type reference : RLC-410W

Standards : FCC Part15 15.407
ANSI C63.10-2013
KDB 662911 D01 v02r01
KDB 789033 D02 v01r02

This device described above has been tested by BCTC, and the test results show that the equipment under test (EUT) is in compliance with the FCC requirements. And it is applicable only to the tested sample identified in the report.

This report shall not be reproduced except in full, without the written approval of BCTC, this document may be altered or revised by BCTC, personal only, and shall be noted in the revision of the document.

Prepared by(Engineer): Cai Fang Zhong Cai Fang Zhong

Reviewer(Supervisor): Eric Yang Eric

Approved(Manager): Zero Zhou Zero Zhou





Table of Contents

	Page
1 . SUMMARY OF TEST RESULTS	6
1.1 TEST FACILITY	7
1.2 MEASUREMENT UNCERTAINTY	7
2 . GENERAL INFORMATION	8
3 . EMC EMISSION TEST	14
3.1 CONDUCTED EMISSION MEASUREMENT	14
3.1.1 POWER LINE CONDUCTED EMISSION LIMITS	14
3.1.2 TEST PROCEDURE	15
3.1.3 DEVIATION FROM TEST STANDARD	15
3.1.4 TEST SETUP	15
3.1.5 EUT OPERATING CONDITIONS	15
3.2 RADIATED EMISSION MEASUREMENT	18
3.2.1 APPLICABLE STANDARD	18
3.2.2 CONFORMANCE LIMIT	18
3.2.3 MEASURING INSTRUMENTS	18
3.2.4 TEST CONFIGURATION	19
3.2.5 TEST PROCEDURE	20
3.2.6 TEST RESULTS (9KHZ – 30 MHZ)	21
3.2.7 TEST RESULTS (30MHZ – 1GHZ)	22
3.2.8 TEST RESULTS (1GHZ-40GHZ)	24
4 . POWER SPECTRAL DENSITY TEST	30
4.1 APPLIED PROCEDURES / LIMIT	30
4.2 TEST PROCEDURE	31
4.3 DEVIATION FROM STANDARD	31
4.4 TEST SETUP	31
4.5 EUT OPERATION CONDITIONS	31
4.6 TEST RESULTS	32
5 . 26DB & 99% & 6DB EMISSION BANDWIDTH	46
5.1 APPLIED PROCEDURES / LIMIT	46
5.2 TEST PROCEDURE	46
5.3 EUT OPERATION CONDITIONS	46
5.4 TEST RESULTS	47
Antenna A:	47
6 . MAXIMUM CONDUCTED OUTPUT POWER	62



Table of Contents

	Page
6.1 PPLIED PROCEDURES / LIMIT	62
6.2 TEST PROCEDURE	62
6.3 DEVIATION FROM STANDARD	63
6.4 TEST SETUP	63
6.5 EUT OPERATION CONDITIONS	64
6.6 TEST RESULTS	65
7 . OUT OF BAND EMISSIONS	67
7.1 APPLICABLE STANDARD	67
7.2 TEST PROCEDURE	67
7.3 DEVIATION FROM STANDARD	67
7.4 TEST SETUP	67
7.5 EUT OPERATION CONDITIONS	68
7.6 TEST RESULTS	69
8.SPURIOUS RF CONDUCTED EMISSIONS	89
8.1CONFORMANCE LIMIT	89
8.2MEASURING INSTRUMENTS	89
8.3TEST SETUP	89
8.4TEST PROCEDURE	89
8.5TEST RESULTS	89
9. FREQUENCY STABILITY MEASUREMENT	106
9.1 LIMIT	106
9.2 TEST PROCEDURES	106
9.3 TEST SETUP LAYOUT	106
9.4 EUT OPERATION DURING TEST	106
9.5 TEST RESULTS	107
10. ANTENNA REQUIREMENT	113
10.1 STANDARD REQUIREMENT	113
10.2 EUT ANTENNA	113
11. EUT TEST PHOTO	114
12. EUT PHOTO	116



Revision History

Report No.	Version	Description	Issued Date
BCTC-FY190603611E	Rev.01	Initial issue of report	Aug. 23, 2019



1. SUMMARY OF TEST RESULTS

Test procedures according to the technical standards:

FCC Part15 (15.407) , Subpart E			
Standard Section	Test Item	Judgment	Remark
15.209(a), 15.407 (b)(1) 15.407 (b)(4) 15.407 (b)(6)	Spurious Radiated Emissions	PASS	
15.407 (a)(1) 15.407 (a)(3) 15.1049	26 dB and 99% Emission Bandwidth	PASS	
15.407(e)	Minimum 6 dB bandwidth	PASS	
15.407 (a)(1) 15.407 (a)(3)	Maximum Conducted Output Power	PASS	
2.1051, 15.407(b)(1) 15.407(b)(4)	Band Edge	PASS	
15.407 (a)(1) 15.407 (a)(3)	Power Spectral Density	PASS	
2.1051, 15.407(b)	Spurious Emissions at Antenna Terminals	PASS	
15.203	Antenna Requirement	PASS	

NOTE:

(1) "N/A" denotes test is not applicable in this Test Report

Outsourcing: The 26G-40G Spurious Radiated Emissions in this test were outsourced to the Shenzhen Academy of Metrology & Quality Inspection



1.1 TEST FACILITY

Shenzhen BCTC Testing Co., Ltd.

Add. : BCTC Building & 1-2F, East of B Building, Pengzhou Industrial, Fuyuan 1st Road, Qiaotou Community, Fuyong Street, Bao'an District, Shenzhen, China

FCC Test Firm Registration Number: 712850

IC Registered No.: 23583

1.2 MEASUREMENT UNCERTAINTY

The reported uncertainty of measurement $y \pm U$, where expanded uncertainty U is based on a standard uncertainty multiplied by a coverage factor of $k=2$, providing a level of confidence of approximately 95 %.

No.	Item	Uncertainty
1	3m chamber Radiated spurious emission(30MHz-1GHz)	U=4.3dB
2	3m chamber Radiated spurious emission(1GHz-18GHz)	U=4.5dB
3	3m chamber Radiated spurious emission(18GHz-40GHz)	U=3.34dB
4	Conducted Adjacent channel power	U=1.38dB
5	Conducted output power uncertainty Above 1G	U=1.576dB
6	Conducted output power uncertainty below 1G	U=1.28dB
7	humidity uncertainty	U=5.3%
8	Temperature uncertainty	U=0.59°C



2. GENERAL INFORMATION

2.1 GENERAL DESCRIPTION OF EUT

Equipment	WiFi IP Camera	
Trade Name		
Model Name	RLC-410W	
Model Difference	N/A	
Product Description	IEEE 802.11 WLAN Mode Supported	<input checked="" type="checkbox"/> 802.11a/n(20MHz channel bandwidth) <input checked="" type="checkbox"/> 802.11n(40MHz channel bandwidth)
	Data Rate	802.11a: 6,9,12,18,24,36,48,54Mbps; 802.11n(HT20/HT40):MCS0-MCS15;
	Modulation	OFDM with BPSK/QPSK/16QAM/64QAM for 802.11a/n;
	Frequency Range	5150-5250MHz; 5725-5850MHz
	Number of Channels	<input checked="" type="checkbox"/> 4 channels for 802.11a/n20 in the 5150-5250MHz band ; <input checked="" type="checkbox"/> 2 channels for 802.11 n40 in the 5150-5250MHz band ; <input checked="" type="checkbox"/> 5 channels for 802.11a/n20 in the 5725-5850MHz band ; <input checked="" type="checkbox"/> 2 channels for 802.11 n40 in the 5725-5850MHz band ;
	Antenna Type	Antenna A&B:FPCB Antenna
	Antenna Gain	Antenna A/B:8.23dBi
	Based on the application, features, or specification exhibited in User's Manual, the EUT is considered as an ITE/Computing Device. More details of EUT technical specification, please refer to the User's Manual.	
Channel List	Please refer to the Note 2.	
Type of device	client devices	
Ratings	DC 12V	
Adapter	Model: DCT12W120100US-B0 Input: 100-240V~50/60Hz 0.3A max. Output: 12.0V 1.0A	
Connecting I/O Port(s)	Please refer to the User's Manual	

Note:

1. For a more detailed features description, please refer to the manufacturer's specifications or the User's Manual.
- 2 The Testing software is "adb command", The power level set "--txpwr 14".



Frequency and Channel list for 802.11a/n(20MHz) band I (5180-5240MHz):

802.11a/n (20MHz) Carrier Frequency Channel							
Channel	Frequency (MHz)	Channel	Frequency (MHz)	Channel	Frequency (MHz)	Channel	Frequency (MHz)
36	5180	44	5220	-	-	-	-
40	5200	48	5240	-	-	-	-

802.11n (40MHz) Carrier Frequency Channel							
Channel	Frequency (MHz)	Channel	Frequency (MHz)	Channel	Frequency (MHz)	Channel	Frequency (MHz)
38	5190	-	-	-	-	-	-
46	5230	-	-	-	-	-	-

Frequency and Channel list for 802.11a/n(20 MHz) band IV (5745-5825MHz):

802.11a/n (20 MHz) Carrier Frequency Channel							
Channel	Frequency (MHz)	Channel	Frequency (MHz)	Channel	Frequency (MHz)	Channel	Frequency (MHz)
149	5745	153	5765	157	5785	161	5805
165	5825	-	-	-	-	-	-

802.11n 40MHz Carrier Frequency Channel					
Channel	Frequency (MHz)	Channel	Frequency (MHz)	Channel	Frequency (MHz)
151	5755	159	5795	-	-

For MIMO mode for 802.11n20, 802.11n40, Directional gain=[10log(GA+ G B)] dBi =6.01dBi

Tx Antenna

Antenna	Antenna Type	Antenna Gain(dBi)
A	R-SMA Antenna	3
B	R-SMA Antenna	3



2.2 DESCRIPTION OF TEST MODES

Pretest Mode	Description
Mode 1	802.11a / n CH36/ CH40/ CH 48 802.11a /n CH149/ CH157/ CH 165
Mode 2	802.11n40 CH38/ CH 46 802.11n40 CH 151 / CH 159
Mode 3	802.11a / n CH36/ CH40/ CH 48 802.11a /n CH149/ CH157/ CH 165
Mode 4	Link Mode

Conducted Emission	
Final Test Mode	Description
Mode 4	Link Mode

For Radiated Emission	
Final Test Mode	Description
Mode 1	802.11a / n CH36/ CH40/ CH 48 802.11a /n CH149/ CH157/ CH 165
Mode 2	802.11n40 CH38/ CH 46 802.11n40 CH 151 / CH 159
Mode 3	802.11a / n CH36/ CH40/ CH 48 802.11a /n CH149/ CH157/ CH 165

Note:

(1) The measurements are performed at all Bit Rate of Transmitter, the worst data was reported.

2.3 BLOCK DIGRAM SHOWING THE CONFIGURATION OF SYSTEM TESTED

Conducted Emission Test

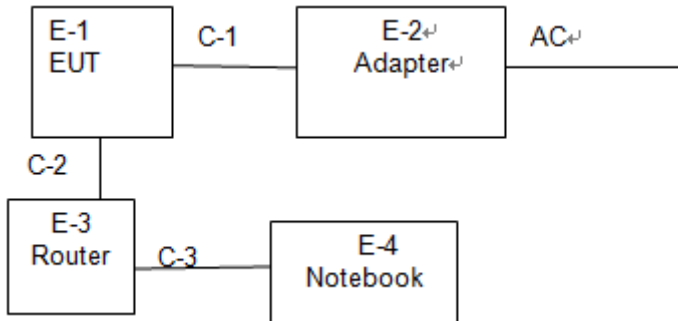

Radiated Spurious Emission

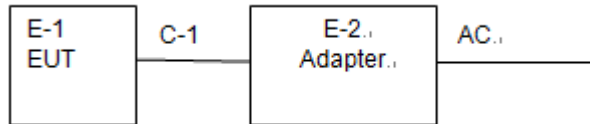

2.4 DESCRIPTION OF SUPPORT UNITS(CONDUCTED MODE)

The EUT has been tested as an independent unit together with other necessary accessories or support units. The following support units or accessories were used to form a representative test configuration during the tests.

Item	Equipment	Mfr/Brand	Model/Type No.	Series No.	Note
E-1	WiFi IP Camera	N/A	RLC-410W	N/A	EUT
E-2	Adapter	N/A	DCT12W120100US-B0	N/A	EUT
E-3	Router	N/A	N/A	N/A	Auxiliary
E-4	Notebook	N/A	N001	N/A	Auxiliary

Item	Shielded Type	Ferrite Core	Length	Note
C-1	NO	NO	1M	DC cableunshielded
C-2	NO	NO	1M	Ethernet cableunshielded
C-3	NO	NO	1M	Ethernet cableunshielded

Note:

- (1) The support equipment was authorized by Declaration of Confirmation.
- (2) For detachable type I/O cable should be specified the length in cm in 『Length』 column.



2.5 EQUIPMENTS LIST FOR ALL TEST ITEMS

Radiation Test equipment

Item	Equipment	Manufacturer	Type No.	Serial No.	Last calibration	Calibrated until
1	Spectrum Analyzer (9kHz-26.5GHz)	Agilent	E4407B	MY45109572	2019.06.13	2020.06.12
2	Test Receiver (9kHz-7GHz)	R&S	ESR7	101154	2019.06.13	2020.06.12
3	Bilog Antenna (30MHz-3GHz)	SCHWARZBECK	VULB9163	VULB9163-942	2019.06.22	2020.06.21
4	Horn Antenna (1GHz-18GHz)	SCHWARZBECK	BBHA9120D	1541	2019.06.22	2020.06.21
5	Horn Antenna (18GHz-40GHz)	SCHWARZBECK	BBHA9170	822	2019.06.22	2020.06.21
6	Amplifier (9KHz-6GHz)	SCHWARZBECK	BBV9744	9744-0037	2019.06.25	2020.06.24
7	Amplifier (0.5GHz-18GHz)	SCHWARZBECK	BBV9718	9718-309	2019.06.25	2020.06.24
8	Amplifier (18GHz-40GHz)	MITEQ	TTA1840-35-HG	2034381	2019.06.17	2020.06.16
9	Loop Antenna (9KHz-30MHz)	SCHWARZBECK	FMZB1519B	014	2019.06.25	2020.06.24
10	RF cables1 (9kHz-30MHz)	Huber+Suhnar	9kHz-30MHz	B1702988-0008	2019.06.25	2020.06.24
11	RF cables2 (30MHz-1GHz)	Huber+Suhnar	30MHz-1GHz	1486150	2019.06.25	2020.06.24
12	RF cables3 (1GHz-40GHz)	Huber+Suhnar	1GHz-40GHz	1607106	2019.06.25	2020.06.24
13	Power Metter	Keysight	E4419	\	2019.06.17	2020.06.16
14	Power Sensor (AV)	Keysight	E9 300A	\	2019.06.17	2020.06.16
15	Spectrum Analyzer 20kHz-26.5GHz	KEYSIGHT	N9020A	MY49100060	2019.06.13	2020.06.12
16	Spectrum Analyzer 9kHz-40GHz	R&S	FSP40	100363	2019.06.13	2020.06.12
17	D.C. Power Supply	LongWei	TPR-6405D	\	\	\
18	Software	Frad	EZ-EMC	FA-03A2 RE	\	\



Conduction Test equipment

Item	Equipment	Manufacturer	Type No.	Serial No.	Last calibration	Calibrated until
1	Test Receiver	R&S	ESR3	102075	2019.06.13	2020.06.12
2	LISN	SCHWARZBEC K	NSLK8127	8127739	2019.06.13	2020.06.12
3	LISN	R&S	ENV216	101375	2019.06.13	2020.06.12
4	RF cables	Huber+Suhnar	9kHz-30MHz	B1702988-00 08	2019.06.25	2020.06.24
5	Software	Frad	EZ-EMC	EMC-CON 3A1	\	\



3. EMC EMISSION TEST

3.1 CONDUCTED EMISSION MEASUREMENT

3.1.1 POWER LINE CONDUCTED EMISSION Limits (Frequency Range 150KHz-30MHz)

FREQUENCY (MHz)	Class B (dBuV)		Standard
	Quasi-peak	Average	
0.15 -0.5	66 - 56 *	56 - 46 *	CISPR
0.50 -5.0	56.00	46.00	CISPR
5.0 -30.0	60.00	50.00	CISPR

0.15 -0.5	66 - 56 *	56 - 46 *	FCC/ RSS-247
0.50 -5.0	56.00	46.00	FCC/ RSS-247
5.0 -30.0	60.00	50.00	FCC/ RSS-247

Note:

- (1) The tighter limit applies at the band edges.
- (2) The limit of " * " marked band means the limitation decreases linearly with the logarithm of the frequency in the range.

The following table is the setting of the receiver

Receiver Parameters	Setting
Attenuation	10 dB
Start Frequency	0.15 MHz
Stop Frequency	30 MHz
IF Bandwidth	9 kHz

3.1.2 TEST PROCEDURE

- a. The EUT was placed 0.8 meters from the horizontal ground plane with EUT being connected to the power mains through a line impedance stabilization network (LISN). All other support equipments powered from additional LISN(s). The LISN provide 50 Ohm/ 50uH of coupling impedance for the measuring instrument.
- b. Interconnecting cables that hang closer than 40 cm to the ground plane shall be folded back and forth in the center forming a bundle 30 to 40 cm long.
- c. I/O cables that are not connected to a peripheral shall be bundled in the center. The end of the cable may be terminated, if required, using the correct terminating impedance. The overall length shall not exceed 1 m.
- d. LISN at least 80 cm from nearest part of EUT chassis.
- e. For the actual test configuration, please refer to the related Item –EUT Test Photos.

3.1.3 DEVIATION FROM TEST STANDARD

No deviation

3.1.4 TEST SETUP

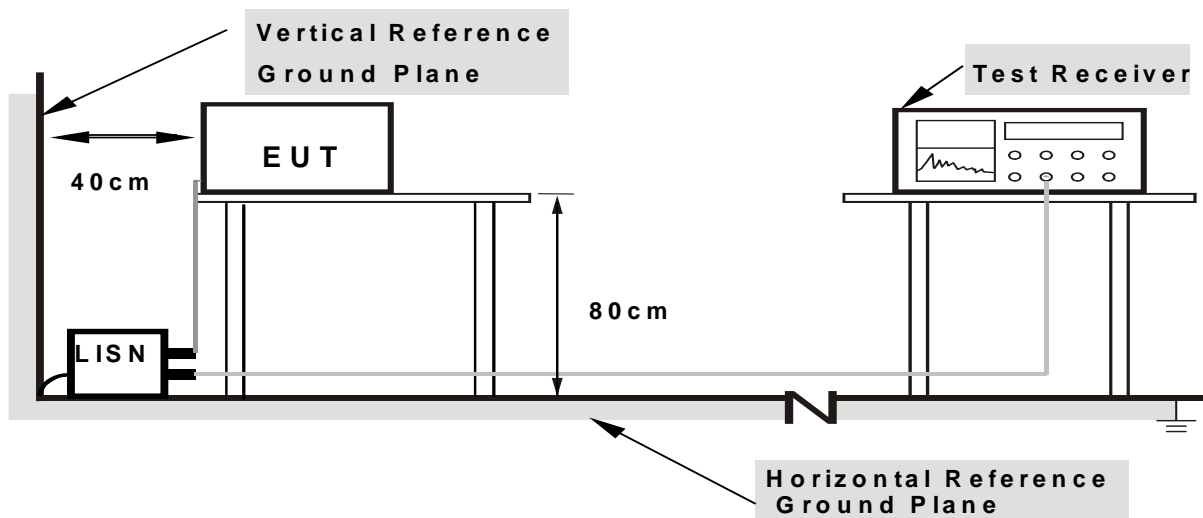

Note: 1.Support units were connected to second LISN.

2.Both of LISNs (AMN) are 80 cm from EUT and at least 80 from other units and other metal planes

3.1.5 EUT OPERATING CONDITIONS

The EUT was configured for testing in a typical fashion (as a customer would normally use it). The EUT has been programmed to continuously transmit during test. This operating condition was tested and used to collect the included data.



Temperature :	26 °C	Relative Humidity :	54%
Pressure :	101kPa	Phase :	L
Test Voltage :	AC 120V/60Hz	Test Mode :	Mode 4

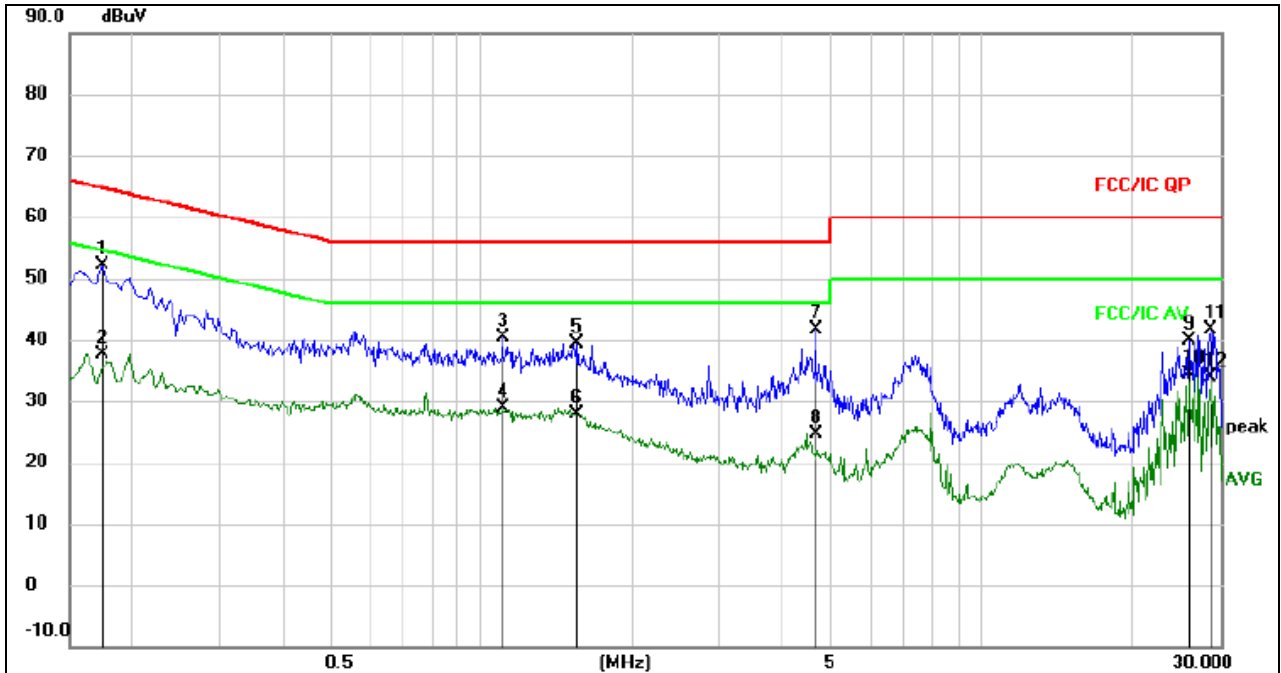

Remark:

1. All readings are Quasi-Peak and Average values.
2. Factor = Insertion Loss + Cable Loss.

No.	Mk.	Freq. MHz	Reading Level dBuV	Correct Factor	Measure- ment dBuV	Limit dBuV	Over dB	Detector	Comment
1	*	0.1740	32.66	19.49	52.15	64.77	-12.62	QP	
2		0.1740	18.06	19.49	37.55	54.77	-17.22	AVG	
3		1.1019	20.72	19.57	40.29	56.00	-15.71	QP	
4		1.1019	9.28	19.57	28.85	46.00	-17.15	AVG	
5		1.5540	19.74	19.58	39.32	56.00	-16.68	QP	
6		1.5540	8.37	19.58	27.95	46.00	-18.05	AVG	
7		4.6500	21.82	19.78	41.60	56.00	-14.40	QP	
8		4.6500	4.74	19.78	24.52	46.00	-21.48	AVG	
9		25.8778	20.26	19.74	40.00	60.00	-20.00	QP	
10		25.8778	14.65	19.74	34.39	50.00	-15.61	AVG	
11		28.8860	21.94	19.71	41.65	60.00	-18.35	QP	
12		28.8860	14.10	19.71	33.81	50.00	-16.19	AVG	



Temperature :	26 °C	Relative Humidity :	54%
Pressure :	101kPa	Phase :	N
Test Voltage :	AC 120V/60Hz	Test Mode :	Mode 4

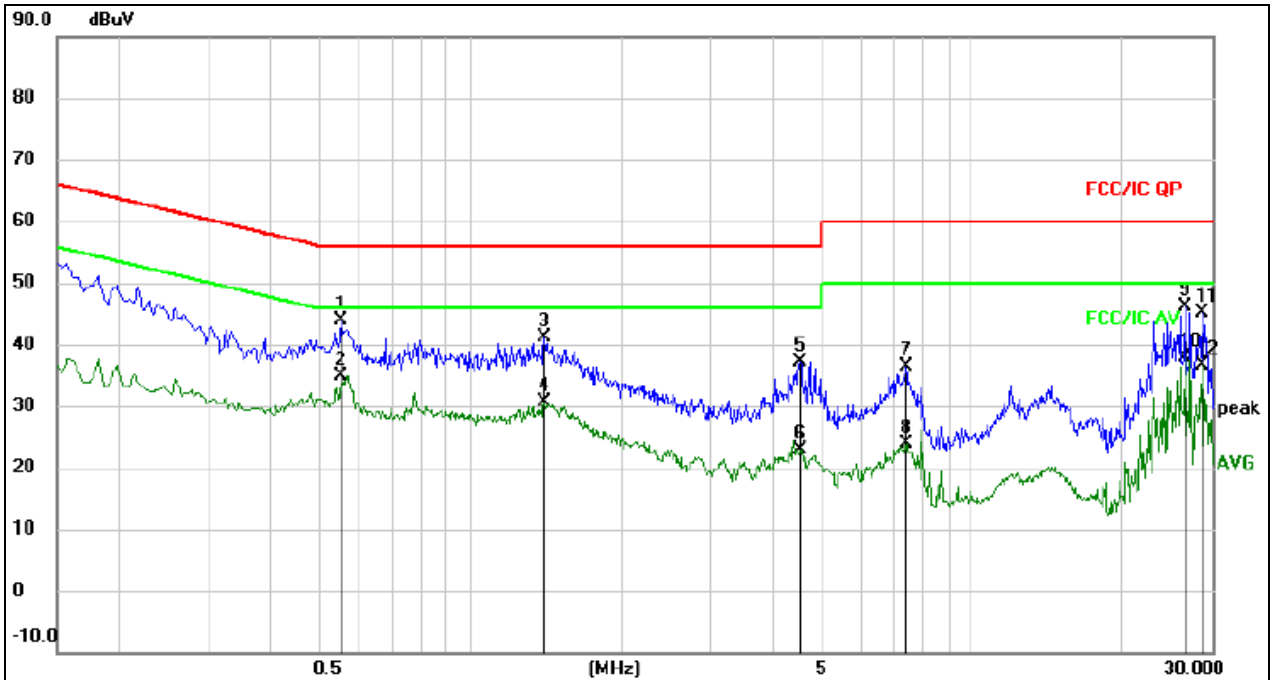

Remark:

1. All readings are Quasi-Peak and Average values.
2. Factor = Insertion Loss + Cable Loss.

No.	Mk.	Freq. MHz	Reading Level dBuV	Correct Factor	Measure- ment dBuV	Limit dBuV	Over dB	Detector	Comment
1		0.5540	24.18	19.81	43.99	56.00	-12.01	QP	
2	*	0.5540	15.03	19.81	34.84	46.00	-11.16	AVG	
3		1.4060	21.47	19.58	41.05	56.00	-14.95	QP	
4		1.4060	10.96	19.58	30.54	46.00	-15.46	AVG	
5		4.5259	17.26	19.77	37.03	56.00	-18.97	QP	
6		4.5259	3.23	19.77	23.00	46.00	-23.00	AVG	
7		7.3779	16.77	19.72	36.49	60.00	-23.51	QP	
8		7.3779	4.20	19.72	23.92	50.00	-26.08	AVG	
9		26.6100	26.29	19.73	46.02	60.00	-13.98	QP	
10		26.6100	18.15	19.73	37.88	50.00	-12.12	AVG	
11		28.6860	25.38	19.71	45.09	60.00	-14.91	QP	
12		28.6860	16.87	19.71	36.58	50.00	-13.42	AVG	



3.2 RADIATED EMISSION MEASUREMENT

3.2.1 APPLICABLE STANDARD

According to FCC Part 15.407(d) and 15.209

3.2.2 CONFORMANCE LIMIT

According to FCC Part 15.407(b)(7): radiated emissions which fall in the restricted bands, as defined in §15.205(a), must also comply with the radiated emission limits specified in §15.209(a) (see §15.205(c)).
According to FCC Part 15.205, Restricted bands

MHz	MHz	MHz	GHz
0.090-0.110	16.42-16.423	399.9-410	4.5-5.15
10.495-0.505	16.69475-16.69525	608-614	5.35-5.46
2.1735-2.1905	16.80425-16.80475	960-1240	7.25-7.75
4.125-4.128	25.5-25.67	1300-1427	8.025-8.5
4.17725-4.17775	37.5-38.25	1435-1626.5	9.0-9.2
4.20725-4.20775	73-74.6	1645.5-1646.5	9.3-9.5
6.215-6.218	74.8-75.2	1660-1710	10.6-12.7
6.26775-6.26825	123-138	2200-2300	14.47-14.5
8.291-8.294	149.9-150.05	2310-2390	15.35-16.2
8.362-8.366	156.52475-156.52525	2483.5-2500	17.7-21.4
8.37625-8.38675	156.7-156.9	2690-2900	22.01-23.12
8.41425-8.41475	162.0125-167.17	3260-3267	23.6-24.0
12.29-12.293	167.72-173.2	3332-3339	31.2-31.8
12.51975-12.52025	240-285	3345.8-3358	36.43-36.5
12.57675-12.57725	322-335.4	3600-4400	(2)
13.36-13.41			

20dBc in any 100 kHz bandwidth outside the operating frequency band. In case the emission fall within the restricted band specified on 15.205(a), then the 15.209(a) limit in the table below has to be followed.

Restricted Frequency(MHz)	Field Strength (μV/m)	Field Strength (dBμV/m)	Measurement Distance
0.009~0.490	2400/F(KHz)	20 log (uV/m)	300
0.490~1.705	2400/F(KHz)	20 log (uV/m)	30
1.705~30.0	30	29.5	30
30-88	100	40	3
88-216	150	43.5	3
216-960	200	46	3
Above 960	500	54	3

Limits of Radiated Emission Measurement(Above 1000MHz)

Frequency(MHz)	Class B (dBuV/m) (at 3M)	
	PEAK	AVERAGE
Above 1000	74	54

Remark :1. Emission level in dBuV/m=20 log (uV/m)

2. Measurement was performed at an antenna to the closed point of EUT distance of meters.

3. Distance extrapolation factor =40log(Specific distance/ test distance)(dB);

Limit line=Specific limits(dBuV) + distance extrapolation factor.

3.2.3 MEASURING INSTRUMENTS

The Measuring equipment is listed in the section 6.3 of this test report.

3.2.4 TEST CONFIGURATION

(a) For radiated emissions below 30MHz

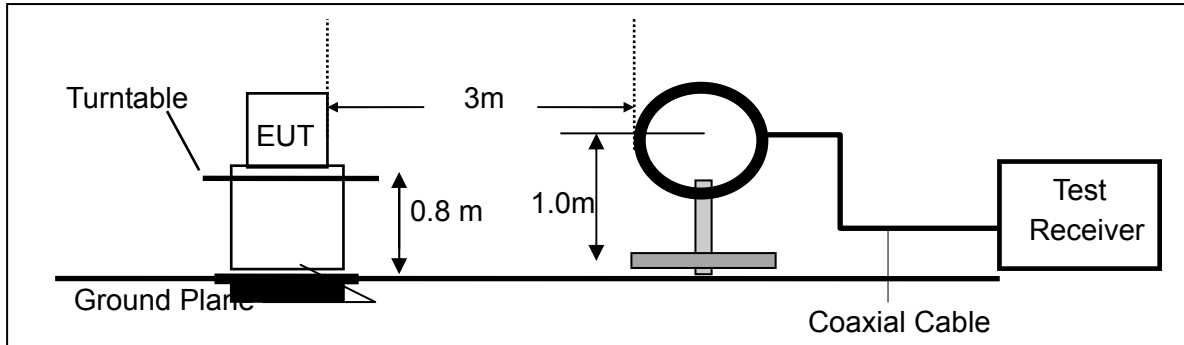

(b) For radiated emissions from 30MHz to 1000MHz

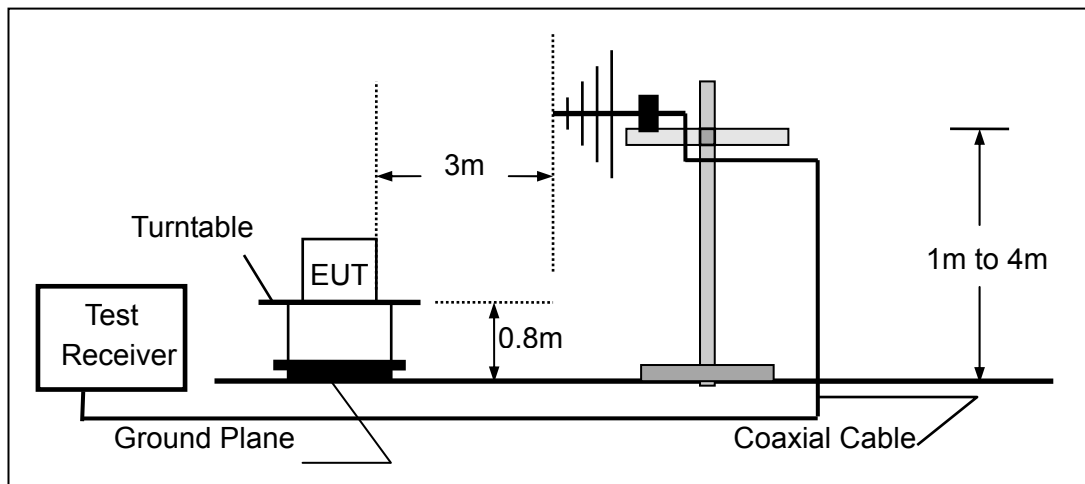

(c) For radiated emissions above 1000MHz

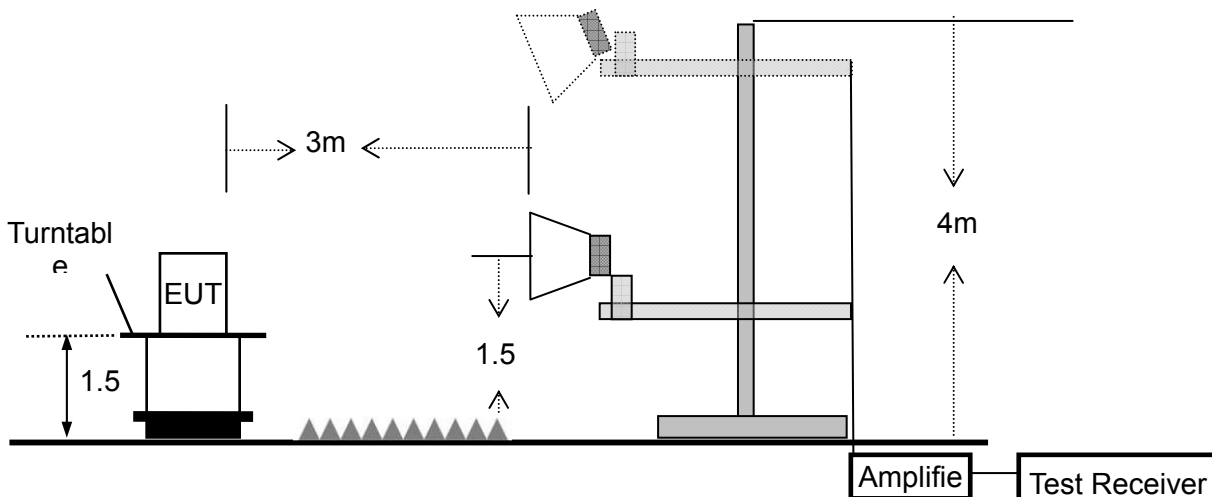



3.2.5 TEST PROCEDURE

The test site semi-anechoic chamber has met the requirement of NSA tolerance 4 dB according to the standards: ANSI C63.10-2013. The test distance is 3m. The setup is according to the requirements in Section 13.1.4.1 of ANSI C63.10-2013 and CAN/CSA-CEI/IEC CISPR 22.

This test is required for any spurious emission that falls in a Restricted Band, as defined in Section 15.205. It must be performed with the highest gain of each type of antenna proposed for use with the EUT.

Use the following spectrum analyzer settings:

Spectrum Parameter	Setting
Attenuation	Auto
Start Frequency	1000 MHz
Stop Frequency	10th carrier harmonic
RB / VB (emission in restricted band)	1 MHz / 1 MHz for Peak, 1 MHz / 10Hz for Average

Receiver Parameter	Setting
Attenuation	Auto
Start ~ Stop Frequency	9kHz~150kHz / RB 200Hz for QP
Start ~ Stop Frequency	150kHz~30MHz / RB 9kHz for QP
Start ~ Stop Frequency	30MHz~1000MHz / RB 120kHz for QP

- The measuring distance of at 3 m shall be used for measurements at frequency up to 1GHz. For frequencies above 1GHz, any suitable measuring distance may be used.
- The EUT was placed on the top of a rotating table 0.8 m for below 1GHz and 1.5m for above 1GHz the ground at a 3 meter. The table was rotated 360 degrees to determine the position of the highest radiation.
- The height of the equipment or of the substitution antenna shall be 0.8 m for below 1GHz and 1.5m for above 1GHz; the height of the test antenna shall vary between 1 m to 4 m. Both horizontal and vertical polarizations of the antenna are set to make the measurement.
- The initial step in collecting conducted emission data is a spectrum analyzer peak detector mode pre-scanning the measurement frequency range. Significant peaks are then marked and then Quasi Peak detector mode re-measured.
- If the Peak Mode measured value compliance with and lower than Quasi Peak Mode Limit, the EUT shall be deemed to meet QP Limits and then no additional QP Mode measurement performed.
- For the actual test configuration, please refer to the related Item –EUT Test Photos.

Note:

Both horizontal and vertical antenna polarities were tested and performed pretest to three orthogonal axis. The worst case emissions were reported

During the radiated emission test, the Spectrum Analyzer was set with the following configurations:

Frequency Band (MHz)	Function	Resolution bandwidth	Video Bandwidth
30 to 1000	QP	120 kHz	300 kHz
Above 1000	Peak	1 MHz	1 MHz
	Average	1 MHz	10 Hz

Note: for the frequency ranges below 30 MHz, a narrower RBW is used for these ranges but the measured value should add a RBW correction factor (RBWCF) where $RBWCF [dB] = 10 * \lg(100 [kHz] / \text{narrower RBW [kHz]})$. , the narrower RBW is 1 kHz and RBWCF is 20 dB for the frequency 9 kHz to 150 kHz, and the narrower RBW is 10 kHz and RBWCF is 10 dB for the frequency 150 kHz to 30 MHz.



3.2.6 TEST RESULTS (9KHZ – 30 MHZ)

Temperature:	26℃	Relative Humidity:	54%
Pressure:	101 kPa	Test Voltage :	AC 120V/60Hz
Test Mode :	Mode 4	Polarization :	--

Freq.	Reading	Limit	Margin	State
(MHz)	(dBuV/m)	(dBuV/m)	(dB)	P/F
--	--	--	--	N/A
--	--	--	--	N/A

NOTE:

The amplitude of spurious emissions which are attenuated by more than 20dB below the permissible value has no need to be reported.

Distance extrapolation factor = $40 \log (\text{specific distance}/\text{test distance})(\text{dB})$;

Limit line = specific limits(dBuv) + distance extrapolation factor.



3.2.7 TEST RESULTS (30MHZ – 1GHZ)

Temperature :	26°C	Relative Humidity :	54%
Pressure :	101 kPa	Test Voltage :	AC 120V/60Hz
Test Mode :	Mode 4		

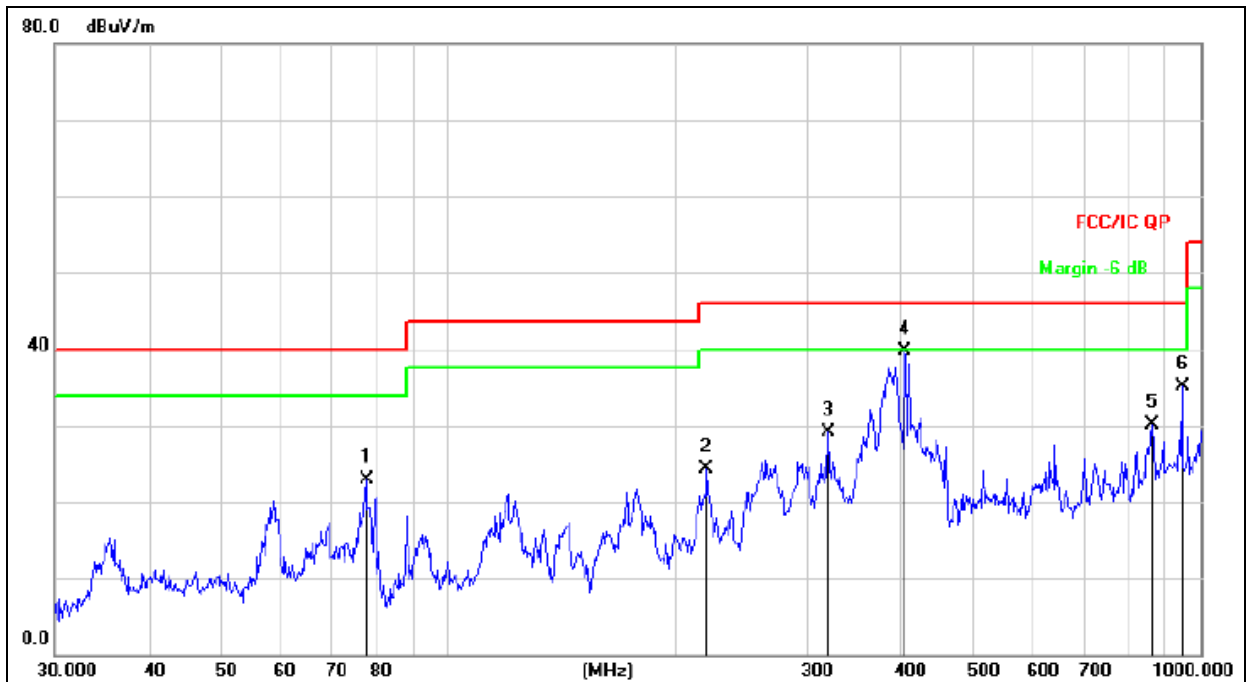

Remark:
Factor = Antenna Factor + Cable Loss – Pre-amplifier.

No.	Mk.	Freq. MHz	Reading Level dBuV	Correct Factor dB	Measure- ment dBuV/m	Limit dB/m	Over dB	Detector
1		77.8653	42.75	-19.94	22.81	40.00	-17.19	QP
2		220.6168	40.05	-15.83	24.22	46.00	-21.78	QP
3		319.9370	42.22	-13.05	29.17	46.00	-16.83	QP
4	*	404.6664	50.73	-10.99	39.74	46.00	-6.26	QP
5		863.0561	32.28	-2.25	30.03	46.00	-15.97	QP
6		945.4397	36.23	-1.15	35.08	46.00	-10.92	QP



Temperature :	26℃	Relative Humidity :	54%
Pressure :	101kPa	Polarization :	Vertical
Test Voltage :	AC 120V/60Hz		
Test Mode :	Mode 4		

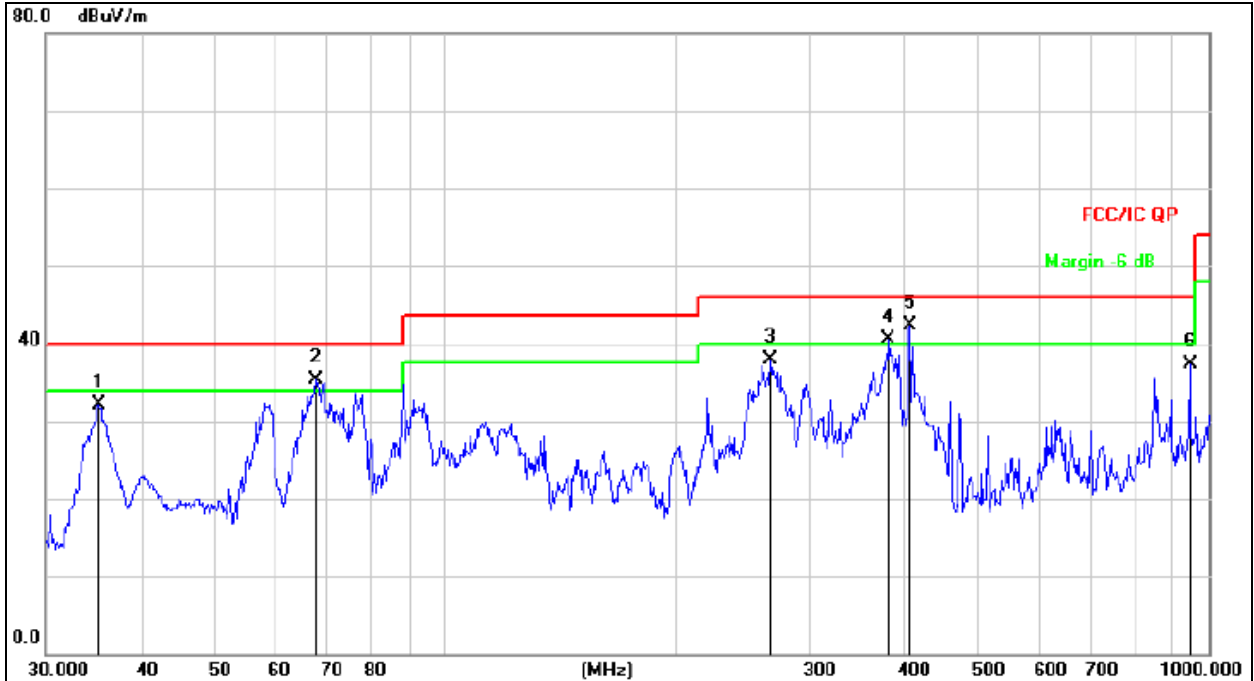

Remark:
Factor = Antenna Factor + Cable Loss – Pre-amplifier.

No.	Mk.	Freq.	Reading Level	Correct Factor	Measurement	Limit	Over	Detector
		MHz	dBuV	dB	dBuV/m	dB/m	dB	
1		35.2511	48.44	-16.30	32.14	40.00	-7.86	QP
2	!	67.6751	53.00	-17.66	35.34	40.00	-4.66	QP
3		266.6089	52.53	-14.64	37.89	46.00	-8.11	QP
4	!	381.2485	52.00	-11.52	40.48	46.00	-5.52	QP
5	*	406.0880	53.31	-10.95	42.36	46.00	-3.64	QP
6		945.4397	38.45	-1.15	37.30	46.00	-8.70	QP



3.2.8 TEST RESULTS (1GHz-40GHz)

Test Mode :	TX(5.2G) - 802.11a
-------------	--------------------

Polar	Frequency	Meter Reading	Cable loss	Antenna Factor	Preamp Factor	Emission Level	Limits	Margin	Detector Type
(H/V)	(MHz)	(dBuV)	(dB)	dB/m	(dB)	(dBuV/m)	(dBuV/m)	(dB)	
Low Channel (5180 MHz)-Above 1G									
Vertical	4635.562	62.26	5.94	35.40	44.00	59.6	74.00	-14.4	Pk
Vertical	4635.562	46.58	5.94	35.40	44.00	43.92	54.00	-10.08	AV
Vertical	11370.362	60.43	8.46	39.75	44.50	64.14	74.00	-9.86	Pk
Vertical	11370.362	42.98	8.46	39.75	44.50	46.69	54.00	-7.31	AV
Vertical	15540.196	61.44	10.12	38.80	44.10	66.26	74.00	-7.74	Pk
Vertical	15540.196	37.57	10.12	38.80	42.70	43.79	54.00	-10.21	AV
Horizontal	4640.562	66.52	5.94	35.18	44.00	63.64	74.00	-10.36	Pk
Horizontal	4640.562	44.18	5.94	35.18	44.00	41.3	54.00	-12.7	AV
Horizontal	11370.362	58.91	8.46	38.71	44.50	61.58	74.00	-12.42	Pk
Horizontal	11370.362	41.06	8.46	38.71	44.50	43.73	54.00	-10.27	AV
Horizontal	15540.196	56.94	10.12	38.38	44.10	61.34	74.00	-12.66	Pk
Horizontal	15540.196	38.87	10.12	38.38	44.10	43.27	54.00	-10.73	AV
middle Channel (5200 MHz)-Above 1G									
Vertical	4592.093	60.27	6.48	36.35	44.05	59.05	74.00	-14.95	Pk
Vertical	4592.093	41.94	6.48	36.35	44.05	40.72	54.00	-13.28	AV
Vertical	12401.424	59.68	8.47	37.88	44.51	61.52	74.00	-12.48	Pk
Vertical	12401.424	42.76	8.47	37.88	44.51	44.6	54.00	-9.4	AV
Vertical	15600.218	56.54	10.12	38.8	44.10	61.36	74.00	-12.64	Pk
Vertical	15600.218	36.67	10.12	38.8	42.70	42.89	54.00	-11.11	AV
Horizontal	4892.691	59.84	6.48	36.37	44.05	58.64	74.00	-15.36	Pk
Horizontal	4892.691	43.18	6.48	36.37	44.05	41.98	54.00	-12.02	AV
Horizontal	12400.114	58.88	8.47	38.64	44.50	61.49	74.00	-12.51	Pk
Horizontal	12400.114	42.28	8.47	38.64	44.50	44.89	54.00	-9.11	AV
Horizontal	15600.187	59.85	10.12	38.38	44.10	64.25	74.00	-9.75	Pk
Horizontal	15600.187	38.78	10.12	38.38	44.10	43.18	54.00	-10.82	AV
High Channel (5240 MHz)-Above 1G									
Vertical	4739.246	61.29	7.10	37.24	43.50	62.13	74.00	-11.87	Pk
Vertical	4739.246	44.45	7.10	37.24	43.50	45.29	54.00	-8.71	AV
Vertical	10980.371	60.58	8.46	37.68	44.50	62.22	74.00	-11.78	Pk
Vertical	10980.371	40.33	8.46	37.68	44.50	41.97	54.00	-12.03	AV
Vertical	15720.359	61.77	10.12	38.8	44.10	66.59	74.00	-7.41	Pk
Vertical	15720.359	39.65	10.12	38.8	42.70	45.87	54.00	-8.13	AV
Horizontal	4739.352	62.28	7.10	37.24	43.50	63.12	74.00	-10.88	Pk
Horizontal	4739.352	43.26	7.10	37.24	43.50	44.1	54.00	-9.9	AV
Horizontal	10881.111	62.58	8.46	38.57	44.50	65.11	74.00	-8.89	Pk
Horizontal	10881.111	43.35	8.46	38.57	44.50	45.88	54.00	-8.12	AV
Horizontal	15720.357	60.72	10.12	38.38	44.10	65.12	74.00	-8.88	Pk
Horizontal	15720.357	42.25	10.12	38.38	44.10	46.65	54.00	-7.35	AV

Note:"802.11n20(5G)" mode is the worst mode. PK value is lower than the Average value limit, So average didn't record.

The amplitude of spurious emissions that are attenuated by more than 20dB below the permissible value has no need to be reported.

Emission level (dBuV/m) = 20 log Emission level (uV/m).

Corrected Reading: Antenna Factor + Cable Loss + Read Level - Preamp Factor = Level.



Test Mode :	TX(5.2G) - 802.11n - HT20
-------------	---------------------------

Polar	Frequency	Meter Reading	Cable loss	Antenna Factor	Preamp Factor	Emission Level	Limits	Margin	Detector Type
(H/V)	(MHz)	(dBuV)	(dB)	dB/m	(dB)	(dBuV/m)	(dBuV/m)	(dB)	
Low Channel (5180 MHz)-Above 1G									
Vertical	4634.155	62.27	5.94	35.40	44.00	59.61	74.00	-14.39	Pk
Vertical	4634.155	46.54	5.94	35.40	44.00	43.88	54.00	-10.12	AV
Vertical	11370.367	60.48	8.46	39.75	44.50	64.19	74.00	-9.81	Pk
Vertical	11370.367	42.92	8.46	39.75	44.50	46.63	54.00	-7.37	AV
Vertical	15540.198	61.47	10.12	38.80	44.10	66.29	74.00	-7.71	Pk
Vertical	15540.198	37.53	10.12	38.80	42.70	43.75	54.00	-10.25	AV
Horizontal	4434.521	66.58	5.94	35.18	44.00	63.7	74.00	-10.3	Pk
Horizontal	4434.521	44.13	5.94	35.18	44.00	41.25	54.00	-12.75	AV
Horizontal	10370.625	58.97	8.46	38.71	44.50	61.64	74.00	-12.36	Pk
Horizontal	10370.625	41.03	8.46	38.71	44.50	43.7	54.00	-10.3	AV
Horizontal	10540.867	56.98	10.12	38.38	44.10	61.38	74.00	-12.62	Pk
Horizontal	10540.867	38.83	10.12	38.38	44.10	43.23	54.00	-10.77	AV
middle Channel (5200 MHz)-Above 1G									
Vertical	4592.095	60.27	6.48	36.35	44.05	59.05	74.00	-14.95	Pk
Vertical	4592.095	41.93	6.48	36.35	44.05	40.71	54.00	-13.29	AV
Vertical	11401.427	59.68	8.47	37.88	44.51	61.52	74.00	-12.48	Pk
Vertical	11401.427	42.73	8.47	37.88	44.51	44.57	54.00	-9.43	AV
Vertical	15600.212	56.57	10.12	38.8	44.10	61.39	74.00	-12.61	Pk
Vertical	15600.218	36.64	10.12	38.8	42.70	42.86	54.00	-11.14	AV
Horizontal	4592.691	59.88	6.48	36.37	44.05	58.68	74.00	-15.32	Pk
Horizontal	4592.691	43.14	6.48	36.37	44.05	41.94	54.00	-12.06	AV
Horizontal	11400.114	58.87	8.47	38.64	44.50	61.48	74.00	-12.52	Pk
Horizontal	11400.115	42.23	8.47	38.64	44.50	44.84	54.00	-9.16	AV
Horizontal	15600.184	59.88	10.12	38.38	44.10	64.28	74.00	-9.72	Pk
Horizontal	15600.184	38.73	10.12	38.38	44.10	43.13	54.00	-10.87	AV
High Channel (5240 MHz)-Above 1G									
Vertical	4739.244	61.27	7.10	37.24	43.50	62.11	74.00	-11.89	Pk
Vertical	4739.244	44.43	7.10	37.24	43.50	45.27	54.00	-8.73	AV
Vertical	11480.376	60.57	8.46	37.68	44.50	62.21	74.00	-11.79	Pk
Vertical	11480.376	40.33	8.46	37.68	44.50	41.97	54.00	-12.03	AV
Vertical	15720.356	61.78	10.12	38.8	44.10	66.6	74.00	-7.4	Pk
Vertical	15720.356	39.63	10.12	38.8	42.70	45.85	54.00	-8.15	AV
Horizontal	4739.354	62.25	7.10	37.24	43.50	63.09	74.00	-10.91	Pk
Horizontal	4739.354	43.27	7.10	37.24	43.50	44.11	54.00	-9.89	AV
Horizontal	11481.114	62.53	8.46	38.57	44.50	65.06	74.00	-8.94	Pk
Horizontal	11481.114	43.38	8.46	38.57	44.50	45.91	54.00	-8.09	AV
Horizontal	15720.357	60.72	10.12	38.38	44.10	65.12	74.00	-8.88	Pk
Horizontal	15720.357	42.28	10.12	38.38	44.10	46.68	54.00	-7.32	AV

Note:"802.11n20(5G)" mode is the worst mode. PK value is lower than the Average value limit, So average didn't record.

The amplitude of spurious emissions that are attenuated by more than 20dB below the permissible value has no need to be reported.

Emission level (dBuV/m) = 20 log Emission level (uV/m).

Corrected Reading: Antenna Factor + Cable Loss + Read Level - Preamp Factor = Level.



Test Mode :	TX(5.2G) - 802.11n-HT40
-------------	-------------------------

Polar	Frequency	Meter Reading	Cable loss	Antenna Factor	Preamp Factor	Emission Level	Limits	Margin	Detector Type
(H/V)	(MHz)	(dBuV)	(dB)	dB/m	(dB)	(dBuV/m)	(dBuV/m)	(dB)	
Low Channel (5190 MHz)-Above 1G									
Vertical	4534.157	62.27	5.94	35.40	44.00	59.61	74.00	-14.39	Pk
Vertical	4534.157	46.54	5.94	35.40	44.00	43.88	54.00	-10.12	AV
Vertical	11380.366	60.48	8.46	39.75	44.50	64.19	74.00	-9.81	Pk
Vertical	11380.366	42.92	8.46	39.75	44.50	46.63	54.00	-7.37	AV
Vertical	15570.195	61.48	10.12	38.80	44.10	66.3	74.00	-7.7	Pk
Vertical	15570.195	37.53	10.12	38.80	42.70	43.75	54.00	-10.25	AV
Horizontal	4534.521	66.58	5.94	35.18	44.00	63.7	74.00	-10.3	Pk
Horizontal	4534.521	44.23	5.94	35.18	44.00	41.35	54.00	-12.65	AV
Horizontal	11380.624	58.87	8.46	38.71	44.50	61.54	74.00	-12.46	Pk
Horizontal	11380.624	41.03	8.46	38.71	44.50	43.7	54.00	-10.3	AV
Horizontal	15570.865	56.92	10.12	38.38	44.10	61.32	74.00	-12.68	Pk
Horizontal	15570.865	38.83	10.12	38.38	44.10	43.23	54.00	-10.77	AV
High Channel (5230 MHz)-Above 1G									
Vertical	4739.246	61.34	7.10	37.24	43.50	62.18	74.00	-11.82	Pk
Vertical	4739.246	44.47	7.10	37.24	43.50	45.31	54.00	-8.69	AV
Vertical	11460.372	60.22	8.46	37.68	44.50	61.86	74.00	-12.14	Pk
Vertical	11460.372	40.48	8.46	37.68	44.50	42.12	54.00	-11.88	AV
Vertical	15690.355	61.63	10.12	38.8	44.10	66.45	74.00	-7.55	Pk
Vertical	15690.355	39.65	10.12	38.8	42.70	45.87	54.00	-8.13	AV
Horizontal	4739.352	62.22	7.10	37.24	43.50	63.06	74.00	-10.94	Pk
Horizontal	4739.352	43.18	7.10	37.24	43.50	44.02	54.00	-9.98	AV
Horizontal	11460.113	62.23	8.46	38.57	44.50	64.76	74.00	-9.24	Pk
Horizontal	11460.113	43.36	8.46	38.57	44.50	45.89	54.00	-8.11	AV
Horizontal	15690.357	60.76	10.12	38.38	44.10	65.16	74.00	-8.84	Pk
Horizontal	15690.357	42.23	10.12	38.38	44.10	46.63	54.00	-7.37	AV

Note: PK value is lower than the Average value limit, So average didn't record.
 The 26.5-40G amplitude of spurious emissions that are attenuated by more than 20dB below the permissible value has no need to be reported.
 Emission level (dBuV/m) = 20 log Emission level (uV/m).
 Corrected Reading: Antenna Factor + Cable Loss + Read Level - Preamp Factor = Level.



Test Mode :	TX (5.8G) -- 802.11a
-------------	----------------------

Polar	Frequency	Meter Reading	Cable loss	Antenna Factor	Preamp Factor	Emission Level	Limits	Margin	Detector Type
(H/V)	(MHz)	(dBuV)	(dB)	dB/m	(dB)	(dBuV/m)	(dBuV/m)	(dB)	
Low Channel (5745 MHz)-Above 1G									
Vertical	4679.195	59.93	5.94	35.40	44.00	57.27	74.00	-16.73	Pk
Vertical	4679.195	39.68	5.94	35.40	44.00	37.02	54.00	-16.98	AV
Vertical	11490.364	59.52	8.46	39.75	44.50	63.23	74.00	-10.77	Pk
Vertical	11490.364	42.16	8.46	39.75	44.50	45.87	54.00	-8.13	AV
Vertical	17835.101	55.54	10.12	38.80	44.10	60.36	74.00	-13.64	Pk
Vertical	17835.101	38.68	10.12	38.80	42.70	44.9	54.00	-9.1	AV
Horizontal	4679.332	57.93	5.94	35.18	44.00	55.05	74.00	-18.95	Pk
Horizontal	4679.332	44.58	5.94	35.18	44.00	41.7	54.00	-12.3	AV
Horizontal	11490.164	56.67	8.46	38.71	44.50	59.34	74.00	-14.66	Pk
Horizontal	11490.164	40.14	8.46	38.71	44.50	42.81	54.00	-11.19	AV
Horizontal	17835.196	58.68	10.12	38.38	44.10	63.08	74.00	-10.92	Pk
Horizontal	17835.196	42.25	10.12	38.38	44.10	46.65	54.00	-7.35	AV
middle Channel (5785 MHz)-Above 1G									
Vertical	4592.228	59.83	6.48	36.35	44.05	58.61	74.00	-15.39	Pk
Vertical	4592.228	43.36	6.48	36.35	44.05	42.14	54.00	-11.86	AV
Vertical	11570.203	59.89	8.47	37.88	44.51	61.73	74.00	-12.27	Pk
Vertical	11570.203	43.29	8.47	37.88	44.51	45.13	54.00	-8.87	AV
Vertical	17855.147	61.15	10.12	38.8	44.10	65.97	74.00	-8.03	Pk
Vertical	17855.147	44.26	10.12	38.8	42.70	50.48	54.00	-3.52	AV
Horizontal	4592.526	52.65	6.48	36.37	44.05	51.45	74.00	-22.55	Pk
Horizontal	4592.526	46.37	6.48	36.37	44.05	45.17	54.00	-8.83	AV
Horizontal	11570.123	64.06	8.47	38.64	44.50	66.67	74.00	-7.33	Pk
Horizontal	11570.123	45.28	8.47	38.64	44.50	47.89	54.00	-6.11	AV
Horizontal	17855.269	53.54	10.12	38.38	44.10	57.94	74.00	-16.06	Pk
Horizontal	17855.269	41.27	10.12	38.38	44.10	45.67	54.00	-8.33	AV
High Channel (5825 MHz)-Above 1G									
Vertical	5439.199	55.65	7.10	37.24	43.50	56.49	74.00	-17.51	Pk
Vertical	5439.199	43.28	7.10	37.24	43.50	44.12	54.00	-9.88	AV
Vertical	11652.562	52.94	8.46	37.68	44.50	54.58	74.00	-19.42	Pk
Vertical	11652.562	43.18	8.46	37.68	44.50	44.82	54.00	-9.18	AV
Vertical	17873.128	54.53	10.12	38.8	44.10	59.35	74.00	-14.65	Pk
Vertical	17873.128	45.38	10.12	38.8	42.70	51.6	54.00	-2.4	AV
Horizontal	5439.232	55.95	7.10	37.24	43.50	56.79	74.00	-17.21	Pk
Horizontal	5439.232	43.38	7.10	37.24	43.50	44.22	54.00	-9.78	AV
Horizontal	11652.319	52.24	8.46	38.57	44.50	54.77	74.00	-19.23	Pk
Horizontal	11652.319	40.16	8.46	38.57	44.50	42.69	54.00	-11.31	AV
Horizontal	17874.062	57.71	10.12	38.38	44.10	62.11	74.00	-11.89	Pk
Horizontal	17874.062	40.37	10.12	38.38	44.10	44.77	54.00	-9.23	AV

Note:"802.11a(5G)" mode is the worst mode. PK value is lower than the Average value limit, So average didn't record.
The amplitude of spurious emissions that are attenuated by more than 20dB below the permissible value has no need to be reported.

Emission level (dBuV/m) = 20 log Emission level (uV/m).

Corrected Reading: Antenna Factor + Cable Loss + Read Level - Preamp Factor = Level.



Test Mode :	TX (5.8G) --802.11n-HT20
-------------	--------------------------

Polar	Frequency	Meter Reading	Cable loss	Antenna Factor	Preamp Factor	Emission Level	Limits	Margin	Detector Type
(H/V)	(MHz)	(dBuV)	(dB)	dB/m	(dB)	(dBuV/m)	(dBuV/m)	(dB)	
Low Channel (5745 MHz)-Above 1G									
Vertical	4679.196	59.83	5.94	35.40	44.00	57.17	74.00	-16.83	Pk
Vertical	4679.196	39.65	5.94	35.40	44.00	36.99	54.00	-17.01	AV
Vertical	11490.365	59.53	8.46	39.75	44.50	63.24	74.00	-10.76	Pk
Vertical	11490.365	42.27	8.46	39.75	44.50	45.98	54.00	-8.02	AV
Vertical	17935.101	55.54	10.12	38.80	44.10	60.36	74.00	-13.64	Pk
Vertical	17935.101	38.68	10.12	38.80	42.70	44.9	54.00	-9.1	AV
Horizontal	4679.333	57.84	5.94	35.18	44.00	54.96	74.00	-19.04	Pk
Horizontal	4679.333	44.58	5.94	35.18	44.00	41.7	54.00	-12.3	AV
Horizontal	11490.164	56.63	8.46	38.71	44.50	59.3	74.00	-14.7	Pk
Horizontal	11490.164	40.15	8.46	38.71	44.50	42.82	54.00	-11.18	AV
Horizontal	17935.196	58.63	10.12	38.38	44.10	63.03	74.00	-10.97	Pk
Horizontal	17935.196	42.12	10.12	38.38	44.10	46.52	54.00	-7.48	AV
middle Channel (5785 MHz)-Above 1G									
Vertical	4592.224	59.88	6.48	36.35	44.05	58.66	74.00	-15.34	Pk
Vertical	4592.224	43.34	6.48	36.35	44.05	42.12	54.00	-11.88	AV
Vertical	11570.203	61.26	8.47	37.88	44.51	63.1	74.00	-10.9	Pk
Vertical	11570.203	43.28	8.47	37.88	44.51	45.12	54.00	-8.88	AV
Vertical	17855.145	61.23	10.12	38.8	44.10	66.05	74.00	-7.95	Pk
Vertical	17855.145	44.22	10.12	38.8	42.70	50.44	54.00	-3.56	AV
Horizontal	4592.526	52.75	6.48	36.37	44.05	51.55	74.00	-22.45	Pk
Horizontal	4592.526	46.33	6.48	36.37	44.05	45.13	54.00	-8.87	AV
Horizontal	11570.121	64.17	8.47	38.64	44.50	66.78	74.00	-7.22	Pk
Horizontal	11570.121	45.25	8.47	38.64	44.50	47.86	54.00	-6.14	AV
Horizontal	17855.269	53.52	10.12	38.38	44.10	57.92	74.00	-16.08	Pk
Horizontal	17855.269	41.25	10.12	38.38	44.10	45.65	54.00	-8.35	AV
High Channel (5825 MHz)-Above 1G									
Vertical	5439.199	55.67	7.10	37.24	43.50	56.51	74.00	-17.49	Pk
Vertical	5439.199	43.33	7.10	37.24	43.50	44.17	54.00	-9.83	AV
Vertical	11652.562	52.87	8.46	37.68	44.50	54.51	74.00	-19.49	Pk
Vertical	11652.562	43.13	8.46	37.68	44.50	44.77	54.00	-9.23	AV
Vertical	17773.128	54.57	10.12	38.8	44.10	59.39	74.00	-14.61	Pk
Vertical	17773.128	45.32	10.12	38.8	42.70	51.54	54.00	-2.46	AV
Horizontal	5439.232	55.97	7.10	37.24	43.50	56.81	74.00	-17.19	Pk
Horizontal	5439.232	43.34	7.10	37.24	43.50	44.18	54.00	-9.82	AV
Horizontal	11652.319	52.37	8.46	38.57	44.50	54.9	74.00	-19.1	Pk
Horizontal	11652.319	40.13	8.46	38.57	44.50	42.66	54.00	-11.34	AV
Horizontal	17774.062	57.73	10.12	38.38	44.10	62.13	74.00	-11.87	Pk
Horizontal	17774.062	40.38	10.12	38.38	44.10	44.78	54.00	-9.22	AV



Test Mode :	TX (5.8G) -- 802.11n-HT40
-------------	---------------------------

Polar	Frequency	Meter Reading	Cable loss	Antenna Factor	Preamp Factor	Emission Level	Limits	Margin	Detector Type
(H/V)	(MHz)	(dBuV)	(dB)	dB/m	(dB)	(dBuV/m)	(dBuV/m)	(dB)	
Low Channel (5755 MHz)-Above 1G									
Vertical	4679.196	59.86	5.94	35.40	44.00	57.2	74.00	-16.8	Pk
Vertical	4679.196	39.63	5.94	35.40	44.00	36.97	54.00	-17.03	AV
Vertical	11510.364	59.56	8.46	39.75	44.50	63.27	74.00	-10.73	Pk
Vertical	11510.364	42.23	8.46	39.75	44.50	45.94	54.00	-8.06	AV
Vertical	17865.104	55.56	10.12	38.80	44.10	60.38	74.00	-13.62	Pk
Vertical	17865.104	38.43	10.12	38.80	42.70	44.65	54.00	-9.35	AV
Horizontal	4679.332	57.66	5.94	35.18	44.00	54.78	74.00	-19.22	Pk
Horizontal	4679.332	44.53	5.94	35.18	44.00	41.65	54.00	-12.35	AV
Horizontal	11510.166	56.66	8.46	38.71	44.50	59.33	74.00	-14.67	Pk
Horizontal	11510.166	40.12	8.46	38.71	44.50	42.79	54.00	-11.21	AV
Horizontal	17865.197	58.66	10.12	38.38	44.10	63.06	74.00	-10.94	Pk
Horizontal	17865.197	42.23	10.12	38.38	44.10	46.63	54.00	-7.37	AV
High Channel (5795 MHz)-Above 1G									
Vertical	5439.195	55.28	7.10	37.24	43.50	56.12	74.00	-17.88	Pk
Vertical	5439.195	43.23	7.10	37.24	43.50	44.07	54.00	-9.93	AV
Vertical	11590.562	52.87	8.46	37.68	44.50	54.51	74.00	-19.49	Pk
Vertical	11590.562	43.13	8.46	37.68	44.50	44.77	54.00	-9.23	AV
Vertical	17885.122	54.58	10.12	38.8	44.10	59.4	74.00	-14.6	Pk
Vertical	17885.122	45.32	10.12	38.8	42.70	51.54	54.00	-2.46	AV
Horizontal	5439.235	55.86	7.10	37.24	43.50	56.7	74.00	-17.3	Pk
Horizontal	5439.235	43.33	7.10	37.24	43.50	44.17	54.00	-9.83	AV
Horizontal	11590.313	52.26	8.46	38.57	44.50	54.79	74.00	-19.21	Pk
Horizontal	11590.313	40.12	8.46	38.57	44.50	42.65	54.00	-11.35	AV
Horizontal	17885.062	57.76	10.12	38.38	44.10	62.16	74.00	-11.84	Pk
Horizontal	17885.062	40.32	10.12	38.38	44.10	44.72	54.00	-9.28	AV

Note: PK value is lower than the Average value limit, So average didn't record.
 The 26.5-40G amplitude of spurious emissions that are attenuated by more than 20dB below the permissible value has no need to be reported.
 Emission level (dBuV/m) = 20 log Emission level (uV/m).
 Corrected Reading: Antenna Factor + Cable Loss + Read Level - Preamp Factor = Level.



4. POWER SPECTRAL DENSITY TEST

4.1 APPLIED PROCEDURES / LIMIT

According to FCC §15.407(a)(3)

For the band 5.15-5.25 GHz,

(i) For an outdoor access point operating in the band 5.15-5.25 GHz, the maximum power spectral density shall not exceed 17 dBm in any 1 megahertz band. If transmitting antennas of directional gain greater than 6 dBi are used, both the maximum conducted output power and the maximum power spectral density shall be reduced by the amount in dB that the directional gain of the antenna exceeds 6 dBi. The maximum e.i.r.p. at any elevation angle above 30 degrees as measured from the horizon must not exceed 125 mW (21 dBm).

(ii) For an indoor access point operating in the band 5.15-5.25 GHz, the maximum power spectral density shall not exceed 17 dBm in any 1 megahertz band. If transmitting antennas of directional gain greater than 6 dBi are used, both the maximum conducted output power and the maximum power spectral density shall be reduced by the amount in dB that the directional gain of the antenna exceeds 6 dBi.

(iii) For fixed point-to-point access points operating in the band 5.15-5.25 GHz, the maximum power spectral density shall not exceed 17 dBm in any 1 megahertz band. Fixed point-to-point U-NII devices may employ antennas with directional gain up to 23 dBi without any corresponding reduction in the maximum conducted output power or maximum power spectral density. For fixed point-to-point transmitters that employ a directional antenna gain greater than 23 dBi, a 1 dB reduction in maximum conducted output power and maximum power spectral density is required for each 1 dB of antenna gain in excess of 23 dBi. Fixed, point-to-point operations exclude the use of point-to-multipoint systems, omnidirectional applications, and multiple collocated transmitters transmitting the same information. The operator of the U-NII device, or if the equipment is professionally installed, the installer, is responsible for ensuring that systems employing high gain directional antennas are used exclusively for fixed, point-to-point operations.

(iv) For client devices in the 5.15-5.25 GHz band, the maximum power spectral density shall not exceed 11 dBm in any 1 megahertz band. If transmitting antennas of directional gain greater than 6 dBi are used, both the maximum conducted output power and the maximum power spectral density shall be reduced by the amount in dB that the directional gain of the antenna exceeds 6 dBi.

For the band 5.725-5.85 GHz

(3) For the band 5.725-5.85 GHz, the maximum power spectral density shall not exceed 30 dBm in any 500-kHz band. If transmitting antennas of directional gain greater than 6 dBi are used, both the maximum conducted output power and the maximum power spectral density shall be reduced by the amount in dB that the directional gain of the antenna exceeds 6 dBi.

,

4.2 TEST PROCEDURE

For devices operating in the bands 5.15-5.25 GHz, 5.25-5.35 GHz, and 5.47-5.725 GHz, the above procedures make use of 1 MHz RBW to satisfy directly the 1 MHz reference bandwidth specified in § 15.407(a)(5). For devices operating in the band 5.725-5.85 GHz, the rules specify a measurement bandwidth of 500 kHz. Many spectrum analyzers do not have 500 kHz RBW, thus a narrower RBW may need to be used. The rules permit the use of a RBWs less than 1 MHz, or 500 kHz, “provided that the measured power is integrated over the full reference bandwidth” to show the total power over the specified measurement bandwidth (i.e., 1 MHz, or 500 kHz). If measurements are performed using a reduced resolution bandwidth (< 1 MHz, or < 500 kHz) and integrated over 1 MHz, or 500 KHz bandwidth, the following adjustments to the procedures apply:

- a) Set $RBW \geq 1/T$, where T is defined in section II.B.I.a).
- b) Set $VBW \geq 3 RBW$.
- c) If measurement bandwidth of Maximum PSD is specified in 500 kHz, add $10\log(500\text{kHz}/RBW)$ to the measured result, whereas RBW (< 500 KHz) is the reduced resolution bandwidth of the spectrum analyzer set during measurement.
- d) If measurement bandwidth of Maximum PSD is specified in 1 MHz, add $10\log(1\text{MHz}/RBW)$ to the measured result, whereas RBW (< 1 MHz) is the reduced resolution bandwidth of spectrum analyzer set during measurement.
- e) Care must be taken to ensure that the measurements are performed during a period of continuous transmission or are corrected upward for duty cycle.

Note: As a practical matter, it is recommended to use reduced RBW of 100 KHz for the sections 5.c) and 5.d) above, since RBW=100 KHZ is available on nearly all spectrum analyzers.

4.3 DEVIATION FROM STANDARD

No deviation.

4.4 TEST SETUP

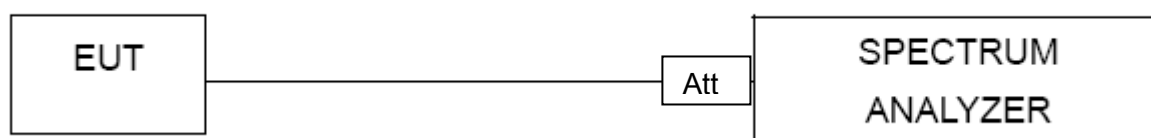

4.5 EUT OPERATION CONDITIONS

The EUT tested system was configured as the statements of 2.1 Unless otherwise a special operating condition is specified in the follows during the testing.



4.6 TEST RESULTS

Temperature :	26 °C	Relative Humidity :	54%
Pressure :	101kPa	Test Voltage :	AC 120V/60Hz
Test Mode :	TX Frequency Band I, TX Frequency Band IV		

TX Frequency Band I (5150-5250MHz)					
Operating mode	Test Channel MHz	Power Spectral Density dBm/MHz			Limit (dBm/MHz)
		ANT A	ANT B	Total	
802.11a	5180	10.86	10.17	/	11
	5200	9.92	10.55	/	11
	5240	9.20	9.19	/	11
802.11n-HT20	5180	8.39	8.24	11.33	10.99
	5200	7.79	8.38	11.11	10.99
	5240	6.96	7.44	10.22	10.99
802.11n-HT40	5190	8.16	9.15	11.69	10.99
	5230	7.54	7.98	10.78	10.99

Antenna A gain: 3dBi, Antenna B gain:3dBi, Directional gain=[10log(GA+ G B)] dbi =6.01dbi



TX Frequency Band IV (5725-5850MHz)						
802.11a						
Test Channel	Power Spectral Density*					Limit dBm/500kHz
	ANT A		ANT B		Total dBm/500kHz	
	dBm/1000kHz	dBm/500kHz	dBm/1000kHz	dBm/500kHz		
5745	4.40	1.39	4.38	1.37	/	30
5785	5.30	2.29	5.34	2.33	/	30
5825	5.76	2.75	5.77	2.76	/	30
802.11n-HT20						
5745	3.01	0.00	2.72	-0.29	2.87	29.99
5785	3.77	0.76	3.62	0.61	3.70	29.99
5825	4.16	1.15	4.29	1.28	4.23	29.99
802.11n-HT40						
5755	1.05	-1.96	0.44	-0.24	1.99	29.99
5795	1.07	-1.94	1.91	0.03	2.17	29.99

Antenna A gain: 3dBi, Antenna B gain: 3dBi, Directional gain=[10log(GA+ G B)] dbi =6.01dbi



Antenna A: 5150-5250MHz

Mode:		802.11a
5180MHz		
5200MHz		
5240MHz		



Mode: 802.11n-HT20

5180MHz



5200MHz



5240MHz





Mode:	802.11n-HT40
5190 MHz	
5230 MHz	



Antenna A: 5725-5850MHz

Mode:		802.11a
5745MHz	<p style="text-align: center;">Date: 20.JUL.2019 15:35:27</p>	
5785MHz	<p style="text-align: center;">Date: 20.JUL.2019 15:36:35</p>	
5825MHz	<p style="text-align: center;">Date: 20.JUL.2019 15:37:45</p>	



Mode: 802.11n-HT20

5745MHz

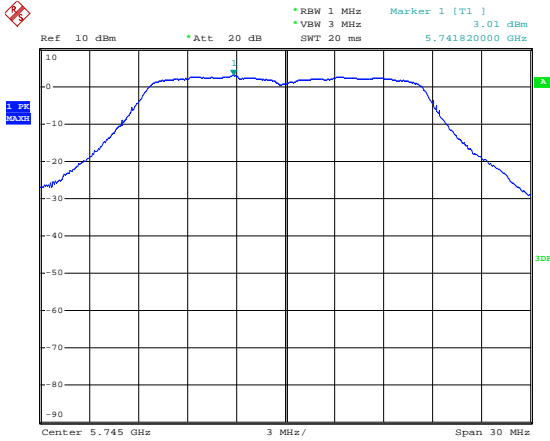

Date: 20.JUL.2019 15:38:42

5785MHz

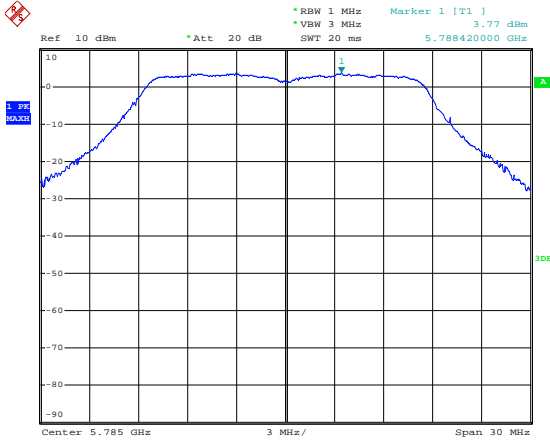

Date: 20.JUL.2019 15:39:54

5825MHz

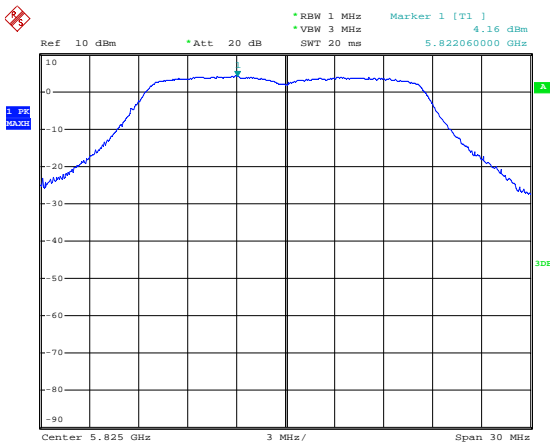

Date: 20.JUL.2019 15:40:46



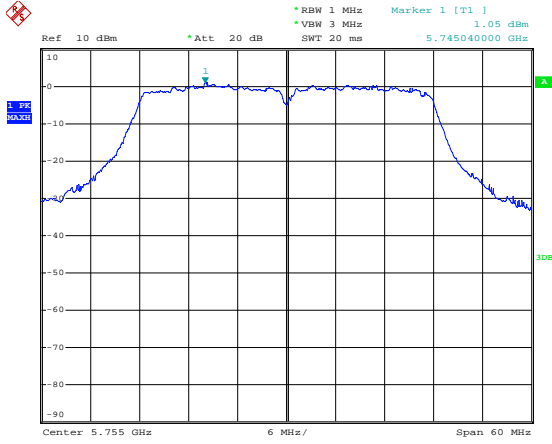
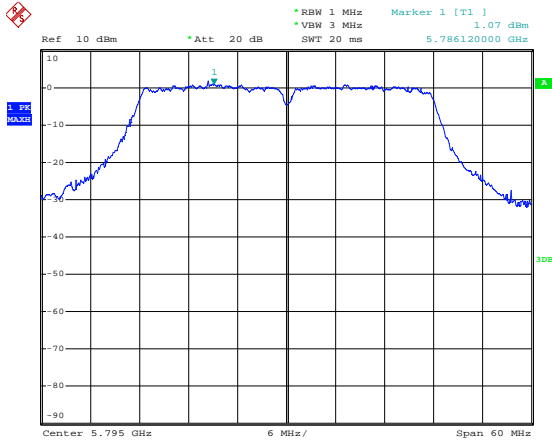

Mode:	802.11n-HT40
5755MHz	 <p>Date: 20.JUL.2019 15:42:04</p>
5795MHz	 <p>Date: 20.JUL.2019 15:43:03</p>



Antenna B: 5150-5250MHz

Mode:	802.11a
5180MHz	
5200MHz	
5240MHz	



Mode:		802.11n-HT20
5180MHz		
5200MHz		
5240MHz		



<p>Mode:</p> <p>5190 MHz</p>	<p>802.11n-HT40</p> 
<p>5230 MHz</p>	



Antenna B: 5725-5850MHz

Mode:		802.11a
5745MHz	<p>Date: 20.JUL.2019 15:36:00</p>	
5785MHz	<p>Date: 20.JUL.2019 15:37:12</p>	
5825MHz	<p>Date: 20.JUL.2019 15:38:03</p>	



Mode: 802.11n-HT20

5745MHz

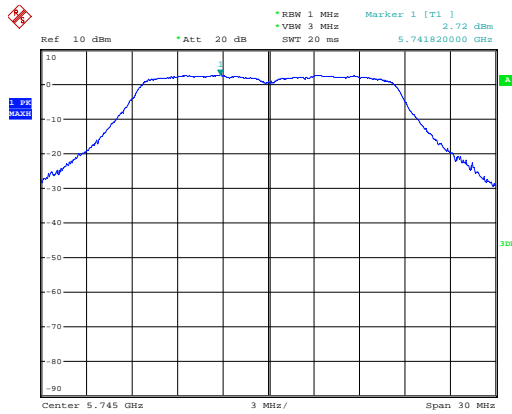

Date: 20.JUL.2019 15:39:23

5785MHz

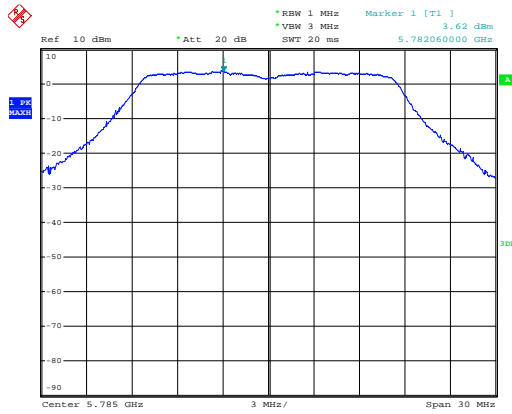

Date: 20.JUL.2019 15:40:15

5825MHz

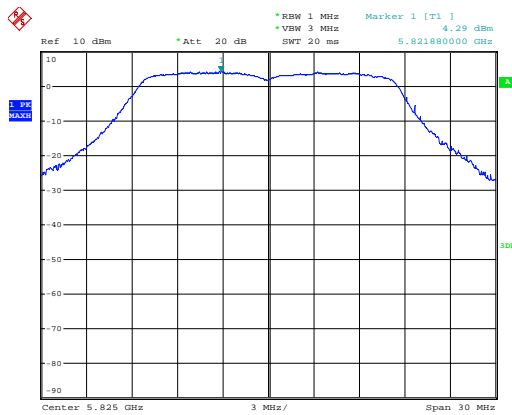

Date: 20.JUL.2019 15:41:06



Mode: 802.11n-HT40

5755MHz

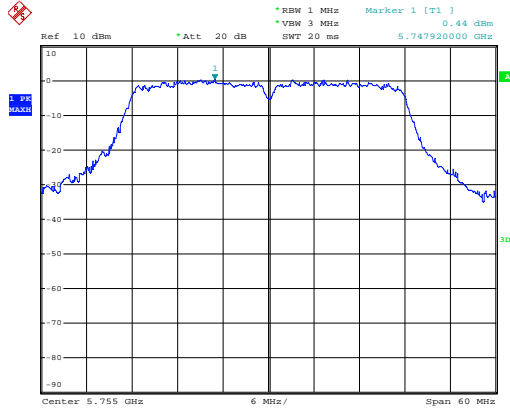

Date: 20.JUL.2019 15:42:24

5795MHz

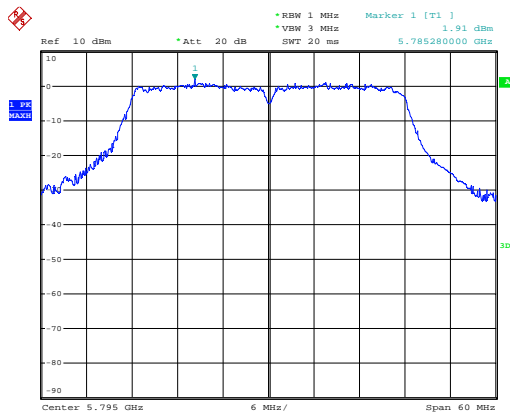

Date: 20.JUL.2019 15:43:32

5. 26DB & 99% & 6DB EMISSION BANDWIDTH

5.1 APPLIED PROCEDURES / LIMIT

The maximum power spectral density is measured as a conducted emission by direct connection of a calibrated test instrument to the equipment under test. If the device cannot be connected directly, alternative techniques acceptable to the Commission may be used. Measurements in the 5.725-5.85 GHz band are made over a reference bandwidth of 500 kHz or the 26 dB emission bandwidth of the device, whichever is less. Measurements in the 5.15-5.25 GHz, 5.25-5.35 GHz, and the 5.47-5.725 GHz bands are made over a bandwidth of 1 MHz or the 26 dB emission bandwidth of the device, whichever is less. A narrower resolution bandwidth can be used, provided that the measured power is integrated over the full reference bandwidth.

5.2 TEST PROCEDURE

- a) Set RBW = approximately 1% of the emission bandwidth.
- b) Set the VBW > RBW.
- c) Detector = Peak.
- d) Trace mode = max hold.
- e) Measure the maximum width of the emission that is 26 dB down from the maximum of the emission. Compare this with the RBW setting of the analyzer. Readjust RBW and repeat measurement as needed until the RBW/EBW ratio is approximately 1%.

The following procedure shall be used for measuring (99 %) power bandwidth:

1. Set center frequency to the nominal EUT channel center frequency.
2. Set span = 1.5 times to 5.0 times the OBW.
3. Set RBW = 1 % to 5 % of the OBW
4. Set VBW $\geq 3 \cdot$ RBW
5. Video averaging is not permitted. Where practical, a sample detection and single sweep mode shall be used. Otherwise, peak detection and max hold mode (until the trace stabilizes) shall be used.
6. Use the 99 % power bandwidth function of the instrument (if available).
7. If the instrument does not have a 99 % power bandwidth function, the trace data points are recovered and directly summed in power units. The recovered amplitude data points, beginning at the lowest frequency, are placed in a running sum until 0.5 % of the total is reached; that frequency is recorded as the lower frequency. The process is repeated until 99.5 % of the total is reached; that frequency is recorded as the upper frequency. The 99% occupied bandwidth is the difference between these two frequencies.

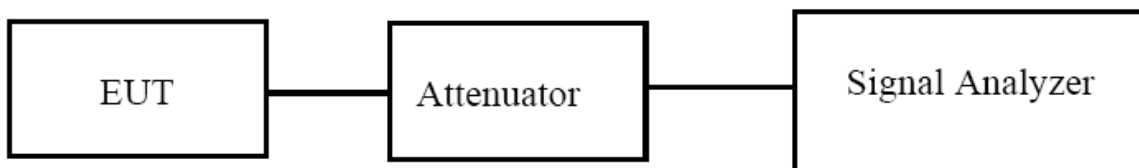

5.3 EUT OPERATION CONDITIONS

The EUT tested system was configured as the statements of 2.4 Unless otherwise a special operating condition is specified in the follows during the testing.



5.4 TEST RESULTS

Antenna A:

5150-5250MHz				
Test Mode	Test Channel MHz	26 dB Bandwidth MHz	99% Bandwidth MHz	Limit MHz
802.11a	5180	25.75	17.78	Pass
	5200	25.69	17.71	Pass
	5240	25.44	17.79	Pass
802.11n-HT20	5180	27.20	18.85	Pass
	5200	27.45	18.92	Pass
	5240	26.66	18.53	Pass
802.11n-HT40	5190	57.42	36.95	Pass
	5230	57.76	36.83	Pass

Antenna A:

5725-5850MHz				
Test Mode	Test Channel MHz	6 dB Bandwidth MHz	99% Bandwidth MHz	Limit MHz
802.11a	5745	16.05	16.675	≥500
	5785	16.45	16.630	≥500
	5825	16.45	16.737	≥500
802.11n-HT20	5745	17.55	17.819	≥500
	5785	17.55	17.831	≥500
	5825	17.49	17.860	≥500
802.11n-HT40	5755	36.49	36.680	≥500
	5795	36.31	36.626	≥500



Antenna B:

5150-5250MHz				
Test Mode	Test Channel MHz	26 dB Bandwidth MHz	99% Bandwidth MHz	Limit MHz
802.11a	5180	25.75	17.75	Pass
	5200	24.78	17.63	Pass
	5240	25.45	17.80	Pass
802.11n-HT20	5180	25.96	18.57	Pass
	5200	27.45	18.93	Pass
	5240	26.99	18.77	Pass
802.11n-HT40	5190	57.34	36.92	Pass
	5230	57.82	36.94	Pass

Antenna B:

5725-5850MHz				
Test Mode	Test Channel MHz	6 dB Bandwidth MHz	99% Bandwidth MHz	Limit MHz
802.11a	5745	16.39	16.623	≥500
	5785	16.47	16.686	≥500
	5825	16.45	16.696	≥500
802.11n-HT20	5745	17.47	17.760	≥500
	5785	17.56	17.791	≥500
	5825	17.45	17.823	≥500
802.11n-HT40	5755	35.93	36.443	≥500
	5795	36.24	36.496	≥500

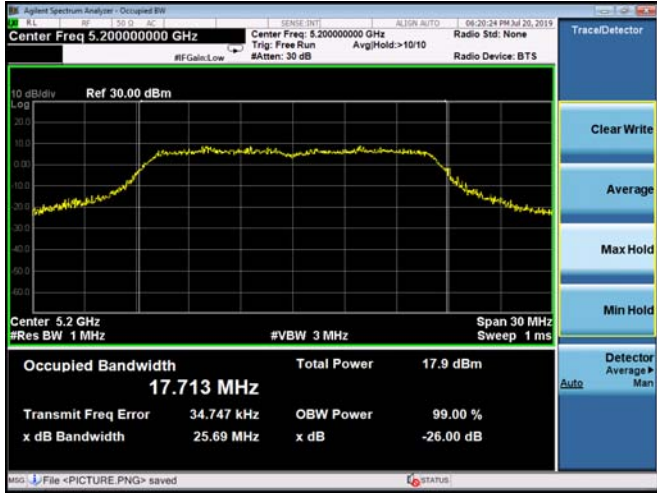

Antenna A: 5150-5250MHz

Mode:	802.11a
5180MHz	 <p>Center Freq: 5.180000000 GHz #Res BW 1 MHz #VBW 3 MHz Span 30 MHz Sweep 1 ms</p> <p>Occupied Bandwidth: 17.780 MHz Total Power: 18.8 dBm</p> <p>Transmit Freq Error: 70.270 kHz OBW Power: 99.00 % x dB Bandwidth: 25.75 MHz x dB: -26.00 dB</p>
5200MHz	 <p>Center Freq: 5.200000000 GHz #Res BW 1 MHz #VBW 3 MHz Span 30 MHz Sweep 1 ms</p> <p>Occupied Bandwidth: 17.713 MHz Total Power: 17.9 dBm</p> <p>Transmit Freq Error: 34.747 kHz OBW Power: 99.00 % x dB Bandwidth: 25.69 MHz x dB: -26.00 dB</p>



5240MHz





Mode:		802.11n-HT20
5180MHz	<p>Agilent Spectrum Analyzer - Occupied BW</p> <p>Center Freq 5.180000000 GHz Center Freq: 5.180000000 GHz Radio Std: None</p> <p>10 dB/div Ref 30.00 dBm</p> <p>Center 5.18 GHz #Res BW 1 MHz #VBW 3 MHz Span 30 MHz Sweep 1 ms</p> <p>Occupied Bandwidth 18.845 MHz Total Power 17.3 dBm</p> <p>Transmit Freq Error -16.191 kHz OBW Power 99.00 %</p> <p>x dB Bandwidth 27.20 MHz x dB -26.00 dB</p>	
5200MHz	<p>Agilent Spectrum Analyzer - Occupied BW</p> <p>Center Freq 5.200000000 GHz Center Freq: 5.200000000 GHz Radio Std: None</p> <p>10 dB/div Ref 30.00 dBm</p> <p>Center 5.2 GHz #Res BW 1 MHz #VBW 3 MHz Span 30 MHz Sweep 1 ms</p> <p>Occupied Bandwidth 18.918 MHz Total Power 17.3 dBm</p> <p>Transmit Freq Error -12.718 kHz OBW Power 99.00 %</p> <p>x dB Bandwidth 27.45 MHz x dB -26.00 dB</p>	
5240MHz	<p>Agilent Spectrum Analyzer - Occupied BW</p> <p>Center Freq 5.240000000 GHz Center Freq: 5.240000000 GHz Radio Std: None</p> <p>10 dB/div Ref 30.00 dBm</p> <p>Center 5.24 GHz #Res BW 1 MHz #VBW 3 MHz Span 30 MHz Sweep 1 ms</p> <p>Occupied Bandwidth 18.534 MHz Total Power 15.5 dBm</p> <p>Transmit Freq Error -62.964 kHz OBW Power 99.00 %</p> <p>x dB Bandwidth 26.66 MHz x dB -26.00 dB</p>	



Mode:	802.11n-HT40
5190 MHz	 <p>Agilent Spectrum Analyzer - Occupied BW</p> <p>Center Freq: 5.190000000 GHz Span 60 MHz Res BW 1 MHz #VBW 3 MHz Sweep 1 ms</p> <p>Occupied Bandwidth: 36.948 MHz Total Power: 20.5 dBm</p> <p>Transmit Freq Error: 2.075 kHz x dB Bandwidth: 57.42 MHz</p> <p>OBW Power: 99.00 % x dB: -26.00 dB</p>
5230 MHz	 <p>Agilent Spectrum Analyzer - Occupied BW</p> <p>Center Freq: 5.230000000 GHz Span 60.000 MHz Res BW 1 MHz #VBW 3 MHz Sweep 1 ms</p> <p>Occupied Bandwidth: 36.829 MHz Total Power: 18.6 dBm</p> <p>Transmit Freq Error: -18.204 kHz x dB Bandwidth: 57.76 MHz</p> <p>OBW Power: 99.00 % x dB: -26.00 dB</p>



Antenna A: 5725-5850MHz

Mode:		802.11a
5745MHz		
5785MHz		
5825MHz		

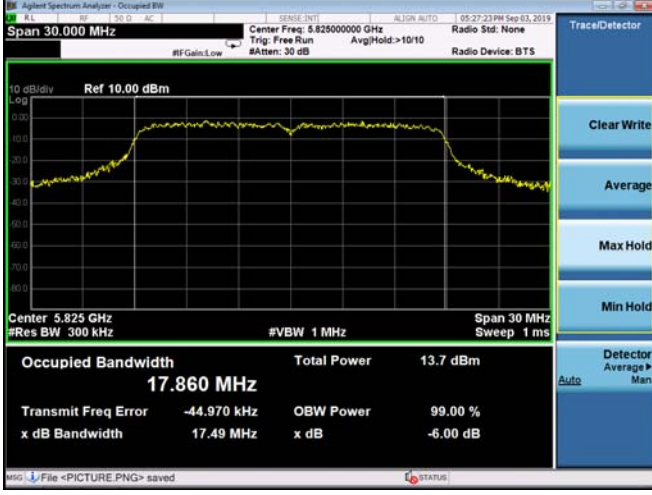

Mode:	802.11n-HT20
5745MHz	 <p>Agilent Spectrum Analyzer - Occupied BW</p> <p>Center Freq: 5.745000000 GHz, Center Freq: 5.745000000 GHz, Radio Std: None</p> <p>Ref 10.00 dBm</p> <p>10 dB/div, Log</p> <p>Center 5.745 GHz, Res BW 300 kHz, Span 30 MHz, Sweep 1 ms</p> <p>Occupied Bandwidth: 17.819 MHz, Total Power: 13.8 dBm</p> <p>Transmit Freq Error: -56.170 kHz, OBW Power: 99.00 %</p> <p>x dB Bandwidth: 17.55 MHz, x dB: -6.00 dB</p>
5785MHz	 <p>Agilent Spectrum Analyzer - Occupied BW</p> <p>Center Freq: 5.785000000 GHz, Center Freq: 5.785000000 GHz, Radio Std: None</p> <p>Ref 10.00 dBm</p> <p>10 dB/div, Log</p> <p>Center 5.785 GHz, Res BW 300 kHz, Span 30 MHz, Sweep 1 ms</p> <p>Occupied Bandwidth: 17.831 MHz, Total Power: 13.6 dBm</p> <p>Transmit Freq Error: -21.577 kHz, OBW Power: 99.00 %</p> <p>x dB Bandwidth: 17.55 MHz, x dB: -6.00 dB</p>
5825MHz	 <p>Agilent Spectrum Analyzer - Occupied BW</p> <p>Center Freq: 5.825000000 GHz, Center Freq: 5.825000000 GHz, Radio Std: None</p> <p>Ref 10.00 dBm</p> <p>10 dB/div, Log</p> <p>Center 5.825 GHz, Res BW 300 kHz, Span 30 MHz, Sweep 1 ms</p> <p>Occupied Bandwidth: 17.860 MHz, Total Power: 13.7 dBm</p> <p>Transmit Freq Error: -44.970 kHz, OBW Power: 99.00 %</p> <p>x dB Bandwidth: 17.49 MHz, x dB: -6.00 dB</p>



Mode:		802.11n-HT40
5755 MHz	<p>Agilent Spectrum Analyzer - Occupied BW</p> <p>Center Freq: 5.755000000 GHz</p> <p>Span 60 MHz</p> <p>Occupied Bandwidth: 36.680 MHz</p> <p>Total Power: 13.0 dBm</p> <p>Transmit Freq Error: -121.40 kHz</p> <p>OBW Power: 99.00 %</p>	
5795 MHz	<p>Agilent Spectrum Analyzer - Occupied BW</p> <p>Center Freq: 5.795000000 GHz</p> <p>Span 60 MHz</p> <p>Occupied Bandwidth: 36.626 MHz</p> <p>Total Power: 12.9 dBm</p> <p>Transmit Freq Error: -62.535 kHz</p> <p>OBW Power: 99.00 %</p>	



Antenna B: 5150-5250MHz

Mode:	802.11a
5180MHz	<p>Agilent Spectrum Analyzer - Occupied BW</p> <p>Center Freq: 5.180000000 GHz</p> <p>Occupied Bandwidth: 17.748 MHz</p> <p>Total Power: 18.6 dBm</p> <p>Transmit Freq Error: 59.722 kHz</p> <p>x dB Bandwidth: 25.75 MHz</p>
5200MHz	<p>Agilent Spectrum Analyzer - Occupied BW</p> <p>Center Freq: 5.200000000 GHz</p> <p>Occupied Bandwidth: 17.629 MHz</p> <p>Total Power: 17.2 dBm</p> <p>Transmit Freq Error: 41.008 kHz</p> <p>x dB Bandwidth: 24.78 MHz</p>
5240MHz	<p>Agilent Spectrum Analyzer - Occupied BW</p> <p>Center Freq: 5.240000000 GHz</p> <p>Occupied Bandwidth: 17.796 MHz</p> <p>Total Power: 17.5 dBm</p> <p>Transmit Freq Error: 7.106 kHz</p> <p>x dB Bandwidth: 25.45 MHz</p>



Mode: **802.11n-HT20**

5180MHz

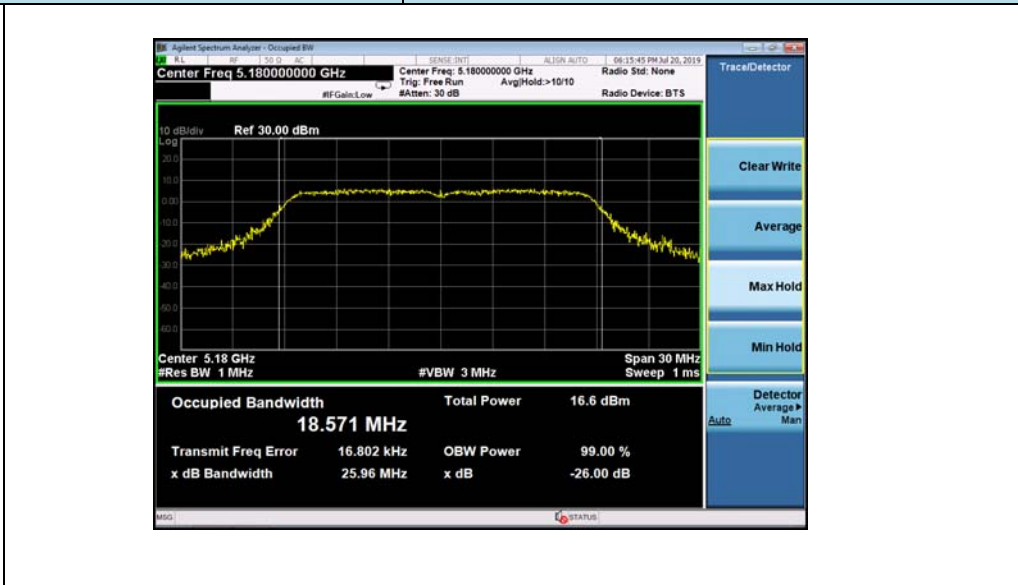

5200MHz



5240MHz

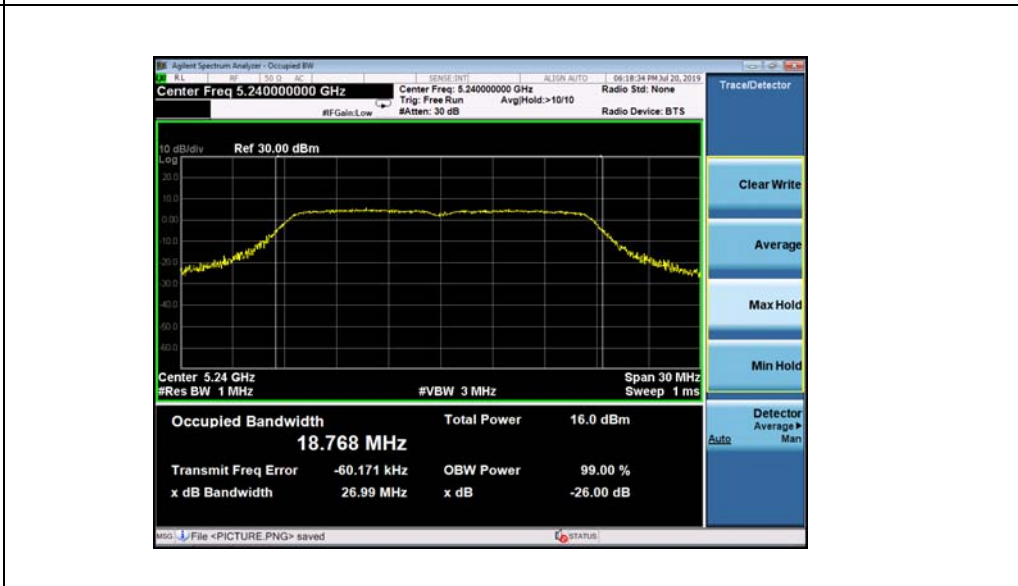

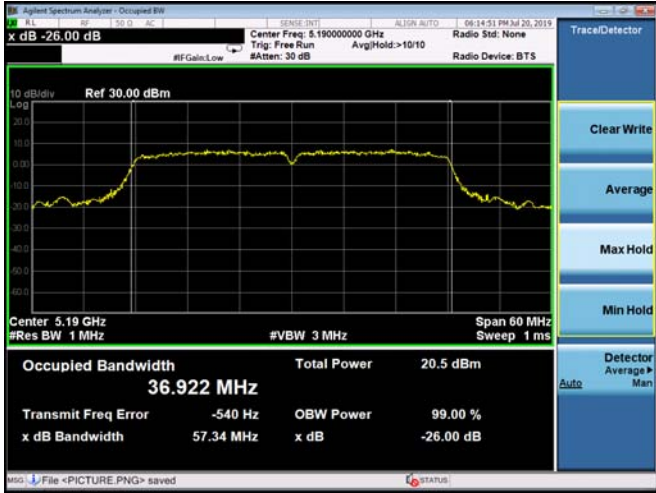
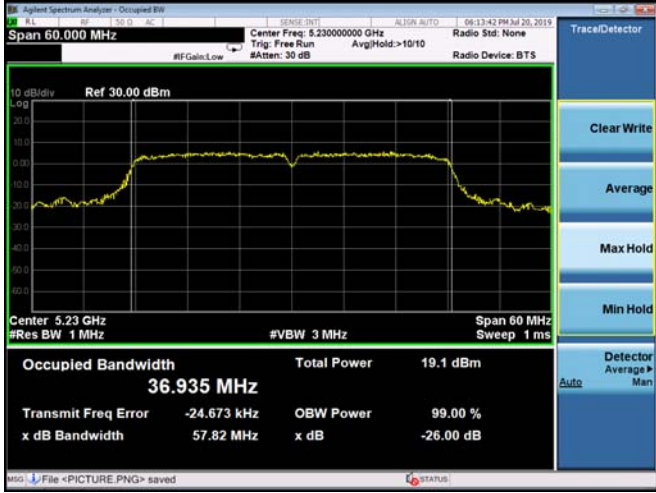

Mode:	802.11n-HT40
5190 MHz	 <p>Agilent Spectrum Analyzer - Occupied BW</p> <p>Center Freq: 5.190000000 GHz</p> <p>Span 60 MHz</p> <p>Occupied Bandwidth: 36.922 MHz</p> <p>Total Power: 20.5 dBm</p> <p>Transmit Freq Error: -540 Hz</p> <p>OBW Power: 99.00 %</p> <p>x dB Bandwidth: 57.34 MHz</p> <p>x dB: -26.00 dB</p>
5230 MHz	 <p>Agilent Spectrum Analyzer - Occupied BW</p> <p>Center Freq: 5.230000000 GHz</p> <p>Span 60.000 MHz</p> <p>Occupied Bandwidth: 36.935 MHz</p> <p>Total Power: 19.1 dBm</p> <p>Transmit Freq Error: -24.673 kHz</p> <p>OBW Power: 99.00 %</p> <p>x dB Bandwidth: 57.82 MHz</p> <p>x dB: -26.00 dB</p>

Antenna B: 5725-5850MHz

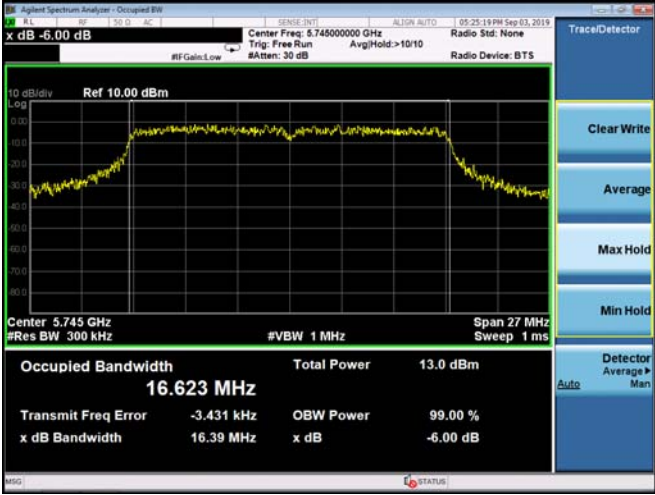
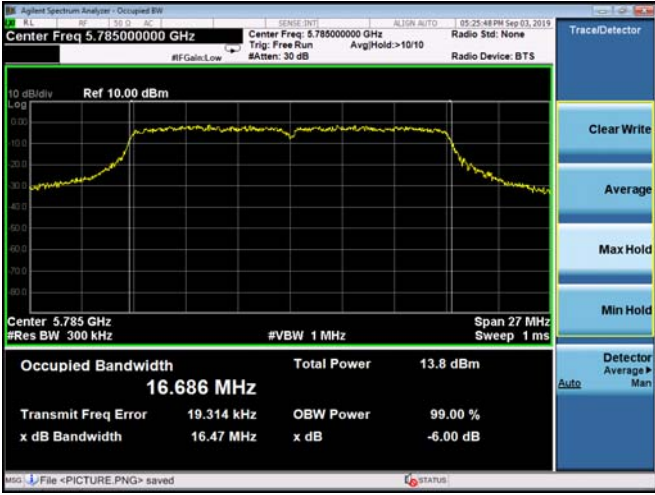
Mode:	802.11a																		
5745MHz	 <p>Agilent Spectrum Analyzer - Occupied BW</p> <p>Center Freq: 5.745000000 GHz Trig: Free Run Avg/Hold: >10/10 Radio Std: None Radio Device: BTS</p> <p>10 dB/div Ref 10.00 dBm</p> <p>Center 5.745 GHz #Res BW 300 kHz #VBW 1 MHz Span 27 MHz Sweep 1 ms</p> <table border="1"> <tr> <td>Occupied Bandwidth</td> <td>Total Power</td> <td>13.0 dBm</td> </tr> <tr> <td>16.623 MHz</td> <td></td> <td></td> </tr> <tr> <td>Transmit Freq Error</td> <td>OBW Power</td> <td>99.00 %</td> </tr> <tr> <td>-3.431 kHz</td> <td></td> <td></td> </tr> <tr> <td>x dB Bandwidth</td> <td>x dB</td> <td>-6.00 dB</td> </tr> <tr> <td>16.39 MHz</td> <td></td> <td></td> </tr> </table>	Occupied Bandwidth	Total Power	13.0 dBm	16.623 MHz			Transmit Freq Error	OBW Power	99.00 %	-3.431 kHz			x dB Bandwidth	x dB	-6.00 dB	16.39 MHz		
Occupied Bandwidth	Total Power	13.0 dBm																	
16.623 MHz																			
Transmit Freq Error	OBW Power	99.00 %																	
-3.431 kHz																			
x dB Bandwidth	x dB	-6.00 dB																	
16.39 MHz																			
5785MHz	 <p>Agilent Spectrum Analyzer - Occupied BW</p> <p>Center Freq: 5.785000000 GHz Trig: Free Run Avg/Hold: >10/10 Radio Std: None Radio Device: BTS</p> <p>10 dB/div Ref 10.00 dBm</p> <p>Center 5.785 GHz #Res BW 300 kHz #VBW 1 MHz Span 27 MHz Sweep 1 ms</p> <table border="1"> <tr> <td>Occupied Bandwidth</td> <td>Total Power</td> <td>13.8 dBm</td> </tr> <tr> <td>16.686 MHz</td> <td></td> <td></td> </tr> <tr> <td>Transmit Freq Error</td> <td>OBW Power</td> <td>99.00 %</td> </tr> <tr> <td>19.314 kHz</td> <td></td> <td></td> </tr> <tr> <td>x dB Bandwidth</td> <td>x dB</td> <td>-6.00 dB</td> </tr> <tr> <td>16.47 MHz</td> <td></td> <td></td> </tr> </table>	Occupied Bandwidth	Total Power	13.8 dBm	16.686 MHz			Transmit Freq Error	OBW Power	99.00 %	19.314 kHz			x dB Bandwidth	x dB	-6.00 dB	16.47 MHz		
Occupied Bandwidth	Total Power	13.8 dBm																	
16.686 MHz																			
Transmit Freq Error	OBW Power	99.00 %																	
19.314 kHz																			
x dB Bandwidth	x dB	-6.00 dB																	
16.47 MHz																			
5825MHz	 <p>Agilent Spectrum Analyzer - Occupied BW</p> <p>Center Freq: 5.825000000 GHz Trig: Free Run Avg/Hold: >10/10 Radio Std: None Radio Device: BTS</p> <p>10 dB/div Ref 10.00 dBm</p> <p>Center 5.825 GHz #Res BW 300 kHz #VBW 1 MHz Span 27 MHz Sweep 1 ms</p> <table border="1"> <tr> <td>Occupied Bandwidth</td> <td>Total Power</td> <td>13.3 dBm</td> </tr> <tr> <td>16.696 MHz</td> <td></td> <td></td> </tr> <tr> <td>Transmit Freq Error</td> <td>OBW Power</td> <td>99.00 %</td> </tr> <tr> <td>35.090 kHz</td> <td></td> <td></td> </tr> <tr> <td>x dB Bandwidth</td> <td>x dB</td> <td>-6.00 dB</td> </tr> <tr> <td>16.45 MHz</td> <td></td> <td></td> </tr> </table>	Occupied Bandwidth	Total Power	13.3 dBm	16.696 MHz			Transmit Freq Error	OBW Power	99.00 %	35.090 kHz			x dB Bandwidth	x dB	-6.00 dB	16.45 MHz		
Occupied Bandwidth	Total Power	13.3 dBm																	
16.696 MHz																			
Transmit Freq Error	OBW Power	99.00 %																	
35.090 kHz																			
x dB Bandwidth	x dB	-6.00 dB																	
16.45 MHz																			



Mode: 802.11n-HT20

5745MHz

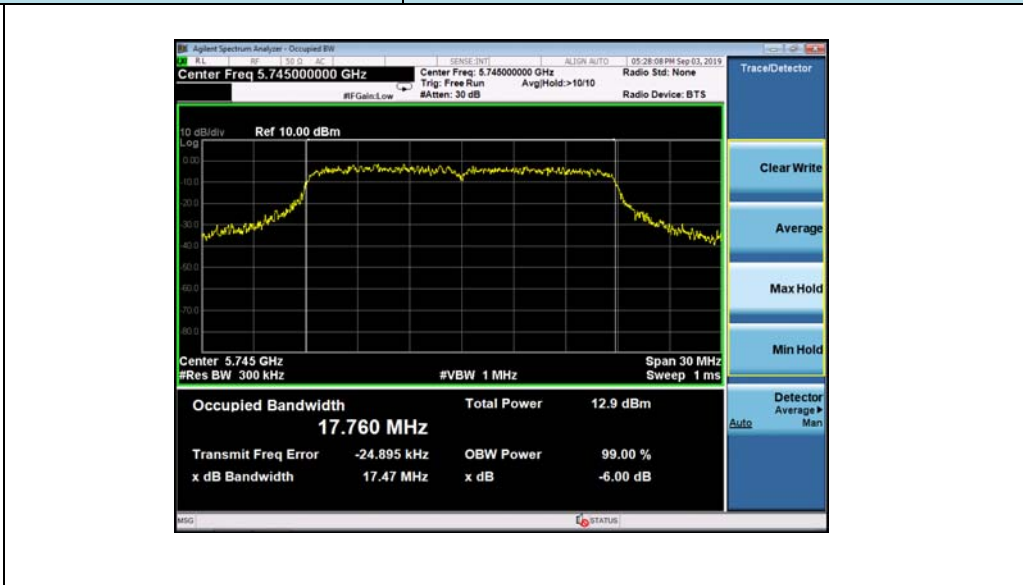

5785MHz



5825MHz

