



### FCC PART 24TEST REPORT Part 24 Subpart E/ RSS-133 Issue 6

Report Reference No.....: HK1809151159-2E

FCC ID.....: 2AL7V-REOLINKGO

IC ID.....: 22869-REOLINKGO

Compiled by  
( position+printed name+signature)..: File administrators Gary Qian

Supervised by  
( position+printed name+signature)..: Technique principal Eden Hu

Approved by  
( position+printed name+signature)..: Manager Jason Zhou

Date of issue.....: Sep. 25, 2018

**Testing Laboratory Name** .....: **Shenzhen HUAKE Testing Technology Co., Ltd.**  
Address .....: 1F, B2 Building, Junfeng Zhongcheng Zhizao Innovation Park,  
Heping Community, Fuhai Street, Bao' an District, Shenzhen,China

**Applicant's name** .....: **Shenzhen Reo-link Digital Technology Co., Ltd.**  
Address .....: 11th Floor, Building C, Unisplendour Information Harbour, North High-  
Tech Zone, Nanshan District, Shenzhen, China,518057

**Test specification** .....:  
Standard .....: **FCC CFR Title 47 Part 2, Part 24E**  
**RSS-133 Issue 6**  
TRF Originator.....: Shenzhen HUAKE Testing Technology Co., Ltd.

**Shenzhen HUAKE Testing Technology Co., Ltd.All rights reserved.**  
This publication may be reproduced in whole or in part for non-commercial purposes as long as the Shenzhen HUAKE Testing Technology Co., Ltd.as copyright owner and source of the material. Shenzhen HUAKE Testing Technology Co., Ltd.takes no responsibility for and will not assume liability for damages resulting from the reader's interpretation of the reproduced material due to its placement and context.

**Test item description** .....: IP Camera  
Trade Mark .....: /  
**Manufacturer** .....: **SHENZHEN BAICHUAN SECURITY TECHNOLOGY CO.,LTD**  
Model/Type reference.....: Reolink GO  
Listed Models .....: N/A  
Modulation Type .....: QPSK, 16QAM  
Rating .....: DC 3.6V From Battery;  
DC 9V or DC 5V from USB  
Hardware version .....: V2.0  
Software version.....: V2.0  
Result.....: **PASS**

**TEST REPORT**

<b>Test Report No. :</b>	<b>HK1809151159-2E</b>	Sep. 25, 2018
		Date of issue

Equipment under Test : IP Camera

Model /Type : Reolink GO

Listed Models : N/A

**Applicant** : **Shenzhen Reo-link Digital Technology Co., Ltd.**

Address : 11th Floor, Building C, Unisplendour Information Harbour,  
North High-Tech Zone, Nanshan District, Shenzhen,  
China,518057

**Manufacturer** : **SHENZHEN BAICHUAN SECURITY TECHNOLOGY  
CO.,LTD**

Address : 2-4th Floor, Building 4, YuanLing Industrial Park,  
ShangWu, Shiyan Street, Bao'an District,Shenzhen,China

<b>Test Result:</b>	<b>PASS</b>
---------------------	-------------

The test report merely corresponds to the test sample.  
It is not permitted to copy extracts of these test result without the written permission of the test laboratory.



### Revision History

Revision	Issue Date	Revisions	Revised By
V1.0	2018-09-25	Initial Issue	James Zhou



## Contents

<b>1</b>	<b><u>TEST STANDARDS.....</u></b>	<b>5</b>
<b>2</b>	<b><u>SUMMARY .....</u></b>	<b>6</b>
2.1	General Remarks	6
2.2	Product Description	6
2.3	Equipment under Test	6
2.4	Short description of the Equipment under Test (EUT)	6
2.5	Normal Accessory setting	7
2.6	EUT configuration	7
2.7	Related Submittal(s) / Grant (s)	7
2.8	Modifications	7
2.9	GeneralTest Conditions/Configurations	7
<b>3</b>	<b><u>TEST ENVIRONMENT.....</u></b>	<b>8</b>
3.1	Address of the test laboratory	8
3.2	Environmental conditions	8
3.3	Test Description	8
3.4	Equipments Used during the Test	9
<b>4</b>	<b><u>TEST CONDITIONS AND RESULTS.....</u></b>	<b>10</b>
4.1	Output Power	10
4.2	Peak-to-Average Ratio (PAR)	16
4.3	Occupied Bandwidth and Emission Bandwidth	23
4.4	Band Edge compliance	30
4.5	Spurious Emssion on Antenna Port	37
4.6	Radiated Spurious Emssion	56
4.7	Frequency Stability	63



# **1 TEST STANDARDS**

The tests were performed according to following standards:

[FCC Part 24](#) :PUBLIC MOBILE SERVICES

[TIA/EIA 603 D June 2010](#):Land Mobile FM or PM Communications Equipment Measurement and Performance Standards.

[47 CFR FCC Part 15 Subpart B](#): - Unintentional Radiators

[FCC Part 2](#): FREQUENCY ALLOCA-TIONS AND RADIO TREATY MAT-TERS; GENERAL RULES AND REG-ULATIONS

[KDB971168 D01.v02r02](#)MEASUREMENT GUIDANCE FOR CERTIFICATION OF LICENSED DIGITAL TRANSMITTERS

[ANSI C63.4:2014](#):Methods of Measurement of Radio-Noise Emissions from Low-Voltage Electrical and Electronic Equipment in the Range of 9 kHz to 40 GHz

[RSS-133 Issue 6](#): 2 GHz Personal Communications Services

[RSS-GEN Issue 5](#): General Requirements for Compliance of Radio Apparatus



## 2 SUMMARY

### 2.1 General Remarks

Date of receipt of test sample	:	Aug.05, 2018
Testing commenced on	:	April 05, 2018
Testing concluded on	:	Sep. 25, 2018

### 2.2 Product Description

The SHENZHEN BAICHUAN SECURITY TECHNOLOGY CO.,LTD's Model:Reolink GO or the "EUT" as referred to in this report; more general information as follows, for more details, refer to the user's manual of the EUT.

Name of EUT	IP Camera
Model/Type reference:	Reolink GO
List Model:	/
Power supply:	DC 3.60V, DC 9V or DC 5V from USB
Modulation Type	QPSK, 16QAM
Antenna Type	Internal
Antenna Gain	-1dBi
Operation Frequency Band	LTE Band 2
Operation frequency	LTE Band 2: 1850.7~1909.3 MHz
LTE Release	R8
Extreme temp. Tolerance	-30°C to +50°C
Extreme vol. Limits	3.40VDC to 4.20VDC (nominal: 3.60VDC)

### 2.3 Equipment under Test

#### Power supply system utilised

Power supply voltage	:	<input type="radio"/> 120V/ 60 Hz	<input type="radio"/> 115V/60Hz
		<input type="radio"/> 12 V DC	<input type="radio"/> 24 V DC
		<input checked="" type="radio"/> Other (specified in blank below)	

DC 3.6V From Battery;  
DC 9V or DC 5V from USB

### 2.4 Short description of the Equipment under Test (EUT)

#### 2.4.1 General Description

This is a IP Camera .

For more details, refer to the user's manual of the EUT



### 2.5 Normal Accessory setting

Fully charged battery was used during the test.

### 2.6 EUT configuration

The following peripheral devices and interface cables were connected during the measurement:

- - supplied by the manufacturer
- - supplied by the lab

<input type="radio"/>	Power Cable	Length (m) :	/
		Shield :	/
		Detachable :	/
<input type="radio"/>	Multimeter	Manufacturer :	/
		Model No. :	/

### 2.7 Related Submittal(s) / Grant (s)

This submittal(s) (test report) is intended for **FCC ID: 2AL7V-REOLINKGO** filing to comply with FCC Part 24, Rules.

### 2.8 Modifications

No modifications were implemented to meet testing criteria.

### 2.9 General Test Conditions/Configurations

#### 2.10.1 Test Environment

Environment Parameter	Selected Values During Tests	
Relative Humidity	Ambient	
Temperature	TN	Ambient
Voltage	VL	3.40V
	VN	3.60V
	VH	4.20V

NOTE: VL=lower extreme test voltage VN=nominal voltage  
VH=upper extreme test voltage TN=normal temperature



### 3 TEST ENVIRONMENT

#### 3.1 Address of the test laboratory

Shenzhen HUAKE Testing Technology Co., Ltd.  
1F, Building No. 13A, Zhonghaixin Science and Technology City, No.12,6 Road, Ganli Industrial Park,  
Buji Street, Longgang District, Shenzhen, Guangdong

#### 3.2 Environmental conditions

During the measurement the environmental conditions were within the listed ranges:

Temperature:	15-35 ° C
Humidity:	30-60 %
Atmospheric pressure:	950-1050mbar

#### 3.3 Test Description

##### PCSBand (1850-1915MHz pairedwith 1930-1995MHz)

Test Item	FCCRuleNo.	Requirements	Verdict
Effective(Isotropic)RadiatedOutputPower	Part§2.1046, Part§24.232 RSS-133§6.4	EIRP ≤ 2W	Pass
Peak-AverageRatio	Part§2.1046, Part§24.232 RSS-133§6.4	FCC:Limit≤13dB	Pass
Bandwidth	Part§2.1049 RSS-133 RSS-GEN§6.7	OBW: Nolimit. EBW: Nolimit.	Pass
BandEdgesCompliance	Part§2.1051, Part§24.238 RSS-133§6.5.1	≤ -13dBm/1%*EBW, In1MHzbandsimmediatelyoutsideandadjacentto Thefrequency block.	Pass
SpuriousEmissionatAntennaTerminals	Part§2.1051, Part§24.238 RSS-133§6.5.1 RSS-GEN	≤-13dBm/1MHz, from9kHzto10thharmonicsbut outsideauthorized Operatingfrequency ranges.	Pass
Field Strengthof Spurious Radiation	Part§2.1053, Part§24.238 RSS-133§6.5.1 RSS-GEN	≤ -13dBm/1MHz.	Pass
Frequency Stability	Part§2.1055, Part§24.235 RSS-133§6.3 RSS-GEN§8.11	FCC:withinauthorizedfrequency block.	Pass

NOTE 1:For the verdict,the“N/A”denotes“not applicable”,the“N/T”denotes “nottested”.

Remark:

1. The measurement uncertainty is not included in the test result.





### 3.4 Equipments Used during the Test

Test Equipment	Manufacturer	Model No.	Serial No.	Calibration Date	Calibration Due Date
LISN	ENV216	R&S	HKE-059	2017/12/28	2018/12/27
LISN	R&S	ENV216	HKE-002	2017/12/28	2018/12/27
Broadband antenna	Schwarzbeck	VULB 9163	HKE-012	2017/12/28	2019/12/26
Receiver	R&S	ESCI 7	HKE-010	2017/12/28	2018/12/27
Spectrum analyzer	Agilent	N9020A	HKE-048	2017/12/28	2018/12/27
RF automatic control unit	Tonscend	JS0806-2	HKE-060	2017/12/28	2018/12/27
Horn antenna	Schwarzbeck	9120D	HKE-013	2017/12/28	2019/12/26
Loop antenna	Schwarzbeck	FMZB 1519 B	HKE-014	2017/12/28	2019/12/26
Preamplifier	EMCI	EMC051845SE	HKE-015	2017/12/28	2018/12/27
Preamplifier	Agilent	83051A	HKE-016	2017/12/28	2018/12/27
Temperature and humidity meter	Boyang	HTC-1	HKE-075	2017/12/28	2018/12/27
High pass filter unit	Tonscend	JS0806-F	HKE-055	2017/12/28	2018/12/27
RF cable	Times	1-40G	HKE-034	2017/12/28	2018/12/27
Power meter	Agilent	E4419B	HKE-085	2017/12/28	2018/12/27
Power Sensor	Agilent	E9300A	HKE-086	2017/12/28	2018/12/27
Wireless Communication Test Set	R&S	CMU200	HKE-026	2017/12/28	2018/12/27

## 4 TEST CONDITIONS AND RESULTS

### 4.1 Output Power

#### 4.1.1 Conducted Output Power

##### TEST APPLICABLE

During the process of testing, the EUT was controlled via R&S Digital Radio Communication tester (CMW500) to ensure max power transmission and proper modulation. This result contains output power and EIRP measurements for the EUT. In all cases, output power is within the specified limits.

##### TEST CONFIGURATION

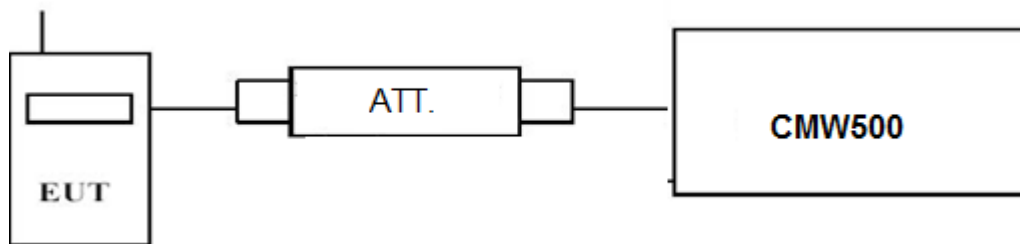

##### TEST PROCEDURE

###### **Conducted Power Measurement:**

- Place the EUT on a bench and set it in transmitting mode.
- Connect a low loss RF cable from the antenna port to a CMW500 by an Att.
- EUT Communicate with CMW500 then selects a channel for testing.
- Add a correction factor to the display CMW500, and then test.

##### TEST RESULTS

Remark:

- We measured all RB Configuration refer 3GPP TS136 521 for each Channel Bandwidth of LTE FDD Band 2;

LTE FDD Band 2				
TX Channel Bandwidth	Frequency (MHz)	RB Size/Offset	Burst Average Power [dBm]	
			QPSK	16QAM
1.4 MHz	1850.7	1 RB low	22.73	21.95
		1 RB high	22.59	21.76
		50% RB mid	22.50	21.57
		100% RB	21.55	20.54
	1880.0	1 RB low	22.82	22.10
		1 RB high	22.81	22.20
		50% RB mid	22.83	21.75
		100% RB	21.71	20.72
	1909.3	1 RB low	22.68	21.71
		1 RB high	22.67	21.80
		50% RB mid	22.73	21.69
		100% RB	21.82	20.72
3 MHz	1851.5	1 RB low	21.87	21.25
		1 RB high	21.95	21.35
		50% RB mid	21.05	20.01
		100% RB	22.03	20.98
	1880.0	1 RB low	22.87	22.15
		1 RB high	22.78	22.08
		50% RB mid	21.89	20.83
		100% RB	21.85	20.85
1908.5	1 RB low	22.70	21.84	



		1 RB high	22.37	21.63	
		50% RB mid	21.76	20.69	
		100% RB	21.73	20.71	
5 MHz	1852.5	1 RB low	21.80	21.06	
		1 RB high	21.85	21.17	
		50% RB mid	21.63	20.55	
			100% RB	21.57	20.53
	1880.0	1 RB low	22.95	22.08	
		1 RB high	22.84	22.07	
		50% RB mid	21.87	20.95	
			100% RB	21.86	20.86
	1907.5	1 RB low	22.83	21.95	
		1 RB high	22.28	21.43	
		50% RB mid	21.83	20.86	
			100% RB	22.25	21.47
10 MHz	1855.0	1 RB low	21.71	20.90	
		1 RB high	22.27	21.71	
		50% RB mid	21.33	20.35	
		100% RB	21.26	20.32	
	1880.0	1 RB low	22.90	22.27	
		1 RB high	22.84	22.06	
		50% RB mid	21.87	20.85	
			100% RB	21.91	20.93
	1905.0	1 RB low	22.20	21.39	
		1 RB high	21.68	20.94	
		50% RB mid	21.36	20.30	
		100% RB	21.84	20.75	
15 MHz	1857.5	1 RB low	21.69	20.93	
		1 RB high	22.72	21.99	
		50% RB mid	21.41	20.35	
		100% RB	21.25	20.27	
	1880.0	1 RB low	22.96	21.48	
		1 RB high	22.87	22.03	
		50% RB mid	22.05	20.96	
			100% RB	22.03	20.96
	1902.5	1 RB low	22.51	21.76	
		1 RB high	21.89	21.20	
		50% RB mid	21.57	20.47	
			100% RB	21.48	20.35
20 MHz	1860.0	1 RB low	21.76	20.97	
		1 RB high	22.99	22.14	
		50% RB mid	21.94	20.86	
		100% RB	21.76	20.92	
	1880.0	1 RB low	23.10	22.39	
		1 RB high	22.68	21.96	
		50% RB mid	22.07	21.13	
			100% RB	21.90	20.98
	1900.0	1 RB low	22.62	21.83	
		1 RB high	21.65	20.97	
		50% RB mid	21.17	20.29	
			100% RB	21.19	20.32

## 4.1.2. Radiated Output Power

### LIMIT

This is the test for the maximum radiated power from the EUT.

Rule Part 24.232(b) specifies, "Mobile/portable stations are limited to 2 watts e.i.r.p.

### TEST CONFIGURATION

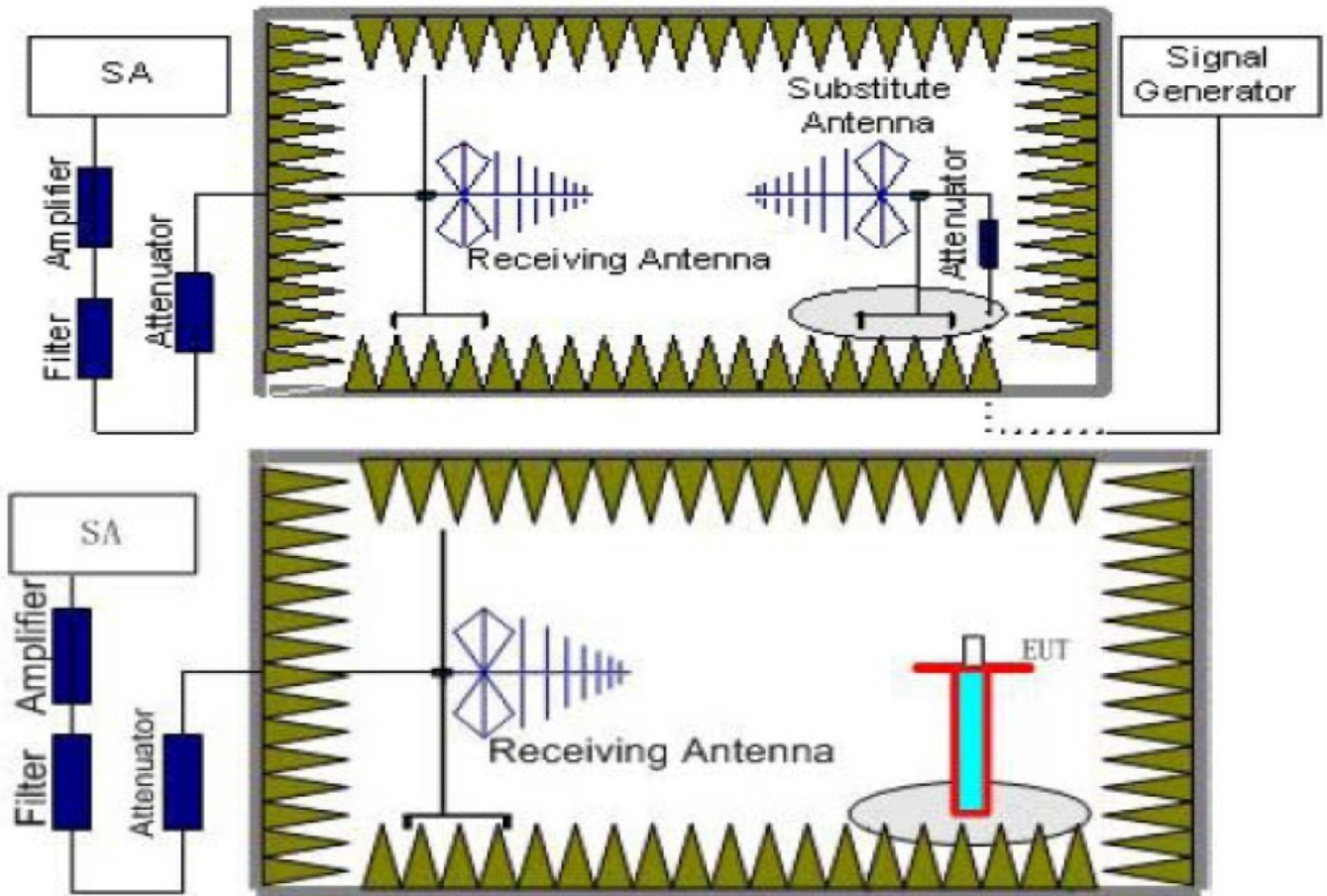

### TEST PROCEDURE

1. EUT was placed on a 1.50 meter high non-conductive stand at a 3 meter test distance from the receive antenna. A receiving antenna was placed on the antenna mast 3 meters from the EUT for emission measurements. The height of receiving antenna is 1.50m. Detected emissions were maximized at each frequency by rotating the EUT through 360° and adjusting the receiving antenna polarization. The radiated emission measurements of all transmit frequencies in three channels (High, Middle, Low) were measured with peak detector.
2. A log-periodic antenna or double-ridged waveguide horn antenna shall be substituted in place of the EUT. The log-periodic antenna will be driven by a signal generator and the level will be adjusted till the same power value on the spectrum analyzer or receiver. The level of the spurious emissions can be calculated through the level of the signal generator, cable loss, the gain of the substitution antenna and the reading of the spectrum analyzer or receiver.
3. The EUT is then put into continuously transmitting mode at its maximum power level during the test. Set Test Receiver or Spectrum RBW=1MHz, VBW=3MHz, And the maximum value of the receiver should be recorded as ( $P_r$ ).
4. The EUT shall be replaced by a substitution antenna. In the chamber, an substitution antenna for the frequency band of interest is placed at the reference point of the chamber. An RF Signal source for the frequency band of interest is connected to the substitution antenna with a cable that has been constructed to not interfere with the radiation pattern of the antenna. A power ( $P_{Mea}$ ) is applied to the input of the substitution antenna, and adjust the level of the signal generator output until the value of the receiver reach the previously recorded ( $P_r$ ). The power of signal source ( $P_{Mea}$ ) is recorded. The test should be performed by rotating the test item and adjusting the receiving antenna polarization.



5. A amplifier should be connected to the Signal Source output port. And the cable should be connect between the Amplifier and the Substitution Antenna. The cable loss ( $P_{cl}$ ), the Substitution Antenna Gain ( $G_a$ ) and the Amplifier Gain ( $P_{Ag}$ ) should be recorded after test.

The measurement results are obtained as described below:

$$\text{Power(EIRP)} = P_{\text{Mea}} - P_{\text{Ag}} - P_{\text{cl}} + G_a$$

We used SMF100A microwave signal generator which signal level can up to 33dBm, so we not used power Amplifier for substitution test; The measurement results are amend as described below:

$$\text{Power(EIRP)} = P_{\text{Mea}} - P_{\text{cl}} + G_a$$

6. This value is EIRP since the measurement is calibrated using an antenna of known gain (2.15 dBi) and known input power.
7. ERP can be calculated from EIRP by subtracting the gain of the dipole,  $\text{ERP} = \text{EIRP} - 2.15\text{dBi}$ .

## TEST RESULTS

### Radiated Measurement:

Remark:

1. We measured all RB Configuration refer 3GPP TS136 521 for each Channel Bandwidth of LTE FDD Band 2; recorded worst case for each Channel Bandwidth of LTE FDD Band 2.
2.  $\text{EIRP} = P_{\text{Mea}}(\text{dBm}) - P_{\text{cl}}(\text{dB}) + P_{\text{Ag}}(\text{dB}) + G_a(\text{dBi})$
3. We measured both Horizontal and Vertical direction, recorded worst case direction.

#### LTE FDD Band 2\_Channel Bandwidth 1.4MHz\_QPSK

Frequency (MHz)	$P_{\text{Mea}}$ (dBm)	$P_{\text{cl}}$ (dB)	$G_a$ Antenna Gain(dB)	$P_{\text{Ag}}$ (dB)	Burst Average EIRP (dBm)	Limit (dBm)	Margin (dB)	Polarization
1850.7	-20.90	3.41	10.24	33.60	19.53	33.01	13.48	V
1880.0	-19.34	3.49	10.24	33.60	21.01	33.01	12.00	V
1909.3	-20.03	3.55	10.23	33.60	20.25	33.01	12.76	V

#### LTE FDD Band 2\_Channel Bandwidth 3MHz\_QPSK

Frequency (MHz)	$P_{\text{Mea}}$ (dBm)	$P_{\text{cl}}$ (dB)	$G_a$ Antenna Gain(dB)	$P_{\text{Ag}}$ (dB)	Burst Average EIRP (dBm)	Limit (dBm)	Margin (dB)	Polarization
1851.5	-21.16	3.41	10.24	33.60	19.86	33.01	13.15	V
1880.0	-19.75	3.49	10.24	33.60	20.29	33.01	12.72	V
1908.5	-19.72	3.55	10.23	33.60	20.31	33.01	12.70	V

#### LTE FDD Band 2\_Channel Bandwidth 5MHz\_QPSK

Frequency (MHz)	$P_{\text{Mea}}$ (dBm)	$P_{\text{cl}}$ (dB)	$G_a$ Antenna Gain(dB)	$P_{\text{Ag}}$ (dB)	Burst Average EIRP (dBm)	Limit (dBm)	Margin (dB)	Polarization
1852.5	-21.16	3.41	10.24	33.60	19.27	33.01	13.74	V
1880.0	-19.09	3.49	10.24	33.60	21.26	33.01	11.75	V
1907.5	-19.73	3.55	10.23	33.60	20.55	33.01	12.46	V

#### LTE FDD Band 2\_Channel Bandwidth 10MHz\_QPSK

Frequency (MHz)	$P_{\text{Mea}}$ (dBm)	$P_{\text{cl}}$ (dB)	$G_a$ Antenna Gain(dB)	$P_{\text{Ag}}$ (dB)	Burst Average EIRP (dBm)	Limit (dBm)	Margin (dB)	Polarization
1855.0	-21.11	3.41	10.24	33.60	19.32	33.01	13.69	V
1880.0	-20.10	3.49	10.24	33.60	20.25	33.01	12.76	V
1905.0	-19.81	3.55	10.23	33.60	20.47	33.01	12.54	V

*LTE FDD Band 2\_Channel Bandwidth 15MHz\_QPSK*

Frequency (MHz)	P <sub>Mea</sub> (dBm)	P <sub>cl</sub> (dB)	G <sub>a</sub> Antenna Gain(dB)	P <sub>Aq</sub> (dB)	Burst Average EIRP (dBm)	Limit (dBm)	Margin (dB)	Polarization
1857.5	-20.96	3.41	10.24	33.60	19.47	33.01	13.54	V
1880.0	-19.99	3.49	10.24	33.60	20.36	33.01	12.65	V
1902.5	-20.14	3.55	10.23	33.60	20.14	33.01	12.87	V

*LTE FDD Band 2\_Channel Bandwidth 20MHz\_QPSK*

Frequency (MHz)	P <sub>Mea</sub> (dBm)	P <sub>cl</sub> (dB)	G <sub>a</sub> Antenna Gain(dB)	P <sub>Aq</sub> (dB)	Burst Average EIRP (dBm)	Limit (dBm)	Margin (dB)	Polarization
1860.0	-20.00	3.41	10.24	33.60	20.45	33.01	12.56	V
1880.0	-19.99	3.49	10.24	33.60	20.35	33.01	12.66	V
1900.0	-20.93	3.55	10.23	33.60	19.39	33.01	13.62	V

*LTE FDD Band 2\_Channel Bandwidth 1.4MHz\_16QAM*

Frequency (MHz)	P <sub>Mea</sub> (dBm)	P <sub>cl</sub> (dB)	G <sub>a</sub> Antenna Gain(dB)	P <sub>Aq</sub> (dB)	Burst Average EIRP (dBm)	Limit (dBm)	Margin (dB)	Polarization
1850.7	-21.88	3.41	10.24	33.60	18.55	33.01	14.46	V
1880.0	-21.25	3.49	10.24	33.60	19.10	33.01	13.91	V
1909.3	-21.10	3.55	10.23	33.60	19.18	33.01	13.83	V

*LTE FDD Band 2\_Channel Bandwidth 3MHz\_16QAM*

Frequency (MHz)	P <sub>Mea</sub> (dBm)	P <sub>cl</sub> (dB)	G <sub>a</sub> Antenna Gain(dB)	P <sub>Aq</sub> (dB)	Burst Average EIRP (dBm)	Limit (dBm)	Margin (dB)	Polarization
1851.5	-22.26	3.41	10.24	33.60	18.17	33.01	14.84	V
1880.0	-21.11	3.49	10.24	33.60	19.24	33.01	13.77	V
1908.5	-21.69	3.55	10.23	33.60	18.59	33.01	14.42	V

*LTE FDD Band 2\_Channel Bandwidth 5MHz\_16QAM*

Frequency (MHz)	P <sub>Mea</sub> (dBm)	P <sub>cl</sub> (dB)	G <sub>a</sub> Antenna Gain(dB)	P <sub>Aq</sub> (dB)	Burst Average EIRP (dBm)	Limit (dBm)	Margin (dB)	Polarization
1852.5	-22.40	3.41	10.24	33.60	18.03	33.01	14.98	V
1880.0	-21.36	3.49	10.24	33.60	18.99	33.01	14.02	V
1907.5	-20.80	3.55	10.23	33.60	19.48	33.01	13.53	V

*LTE FDD Band 2\_Channel Bandwidth 10MHz\_16QAM*

Frequency (MHz)	P <sub>Mea</sub> (dBm)	P <sub>cl</sub> (dB)	G <sub>a</sub> Antenna Gain(dB)	P <sub>Aq</sub> (dB)	Burst Average EIRP (dBm)	Limit (dBm)	Margin (dB)	Polarization
1855.0	-22.44	3.41	10.24	33.60	14.18	33.01	18.83	V
1880.0	-21.23	3.49	10.24	33.60	13.47	33.01	19.54	V
1905.0	-21.36	3.55	10.23	33.60	13.57	33.01	19.44	V

*LTE FDD Band 2\_Channel Bandwidth 15MHz\_16QAM*

Frequency (MHz)	P <sub>Mea</sub> (dBm)	P <sub>cl</sub> (dB)	G <sub>a</sub> Antenna Gain(dB)	P <sub>Aq</sub> (dB)	Burst Average EIRP (dBm)	Limit (dBm)	Margin (dB)	Polarization
1857.5	-22.43	3.41	10.24	33.60	18.00	33.01	15.01	V
1880.0	-21.26	3.49	10.24	33.60	19.09	33.01	13.92	V
1902.5	-21.55	3.55	10.23	33.60	18.73	33.01	14.28	V

*LTE FDD Band 2\_Channel Bandwidth 20MHz\_16QAM*

Frequency (MHz)	$P_{Mea}$ (dBm)	$P_{cl}$ (dB)	$G_a$ Antenna Gain(dB)	$P_{Aq}$ (dB)	Burst Average EIRP (dBm)	Limit (dBm)	Margin (dB)	Polarization
1860.0	-22.21	3.41	10.24	33.60	18.22	33.01	14.79	V
1880.0	-21.53	3.49	10.24	33.60	18.82	33.01	14.19	V
1900.0	-21.99	3.55	10.23	33.60	18.29	33.01	14.72	V



## 4.2 Peak-to-Average Ratio (PAR)

### LIMIT

The Peak-to-Average Ratio (PAR) of the transmission may not exceed 13 dB.

### TEST CONFIGURATION

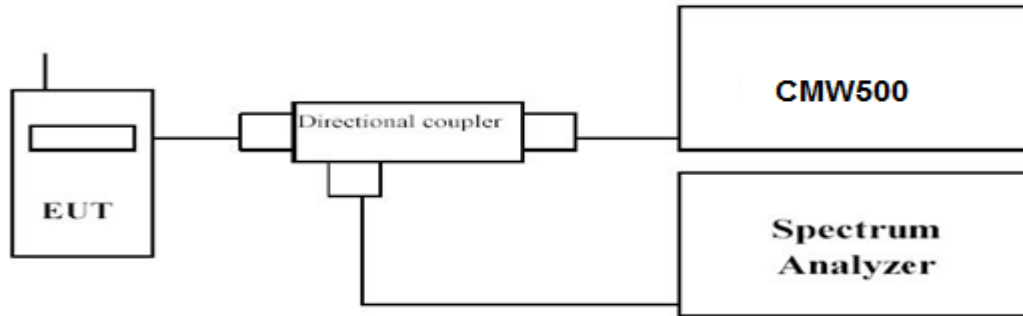

### TEST PROCEDURE

1. Refer to instrument's analyzer instruction manual for details on how to use the power statistics/CCDF function;
2. Set resolution/measurement bandwidth  $\geq$  signal's occupied bandwidth;
3. Set the number of counts to a value that stabilizes the measured CCDF curve;
4. Set the measurement interval as follows:
  - 1). for continuous transmissions, set to 1 ms,
  - 2). for burst transmissions, employ an external trigger that is synchronized with the EUT burst timing sequence, or use the internal burst trigger with a trigger level that allows the burst to stabilize and set the measurement interval to a time that is less than or equal to the burst duration.
5. Record the maximum PAPR level associated with a probability of 0.1%.

### TEST RESULTS

Remark:

1. We measured all RB Configuration refer 3GPP TS136 521 for each Channel Bandwidth of LTE FDD Band 2; recorded worst case for each Channel Bandwidth of LTE FDD Band 2.

LTE FDD Band 2				
TX Channel Bandwidth	Frequency (MHz)	RB Size/Offset	PAPR(dB)	
			QPSK	16QAM
1.4 MHz	1850.7	1RB#0	4.32	4.76
	1880.0		5.28	6.44
	1909.3		5.56	4.36
3 MHz	1851.5	1RB#0	5.28	5.12
	1880.0		5.64	6.08
	1908.5		5.12	6.60
5 MHz	1852.5	1RB#0	4.52	5.24
	1880.0		5.40	6.24
	1907.5		5.52	6.36
10 MHz	1855.0	1RB#0	4.96	5.76
	1880.0		5.40	6.16
	1905.0		5.40	6.36
15 MHz	1857.5	1RB#0	5.76	6.76
	1880.0		5.76	6.72
	1902.5		5.56	6.40
20 MHz	1860.0	1RB#0	6.48	7.20
	1880.0		6.36	7.00
	1900.0		7.04	7.00





LTE FDD Band 2 – 1.4 MHz Channel Bandwidth PAPP

QPSK

16QAM

Low Channel

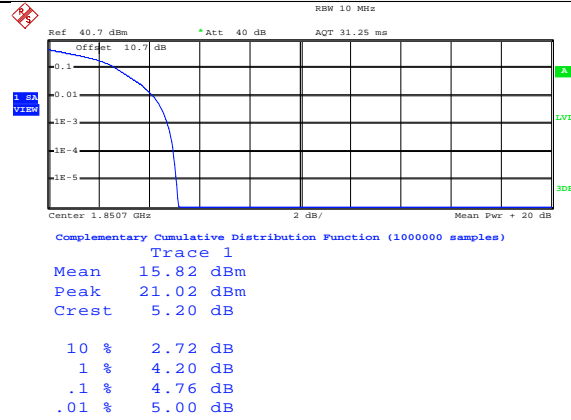
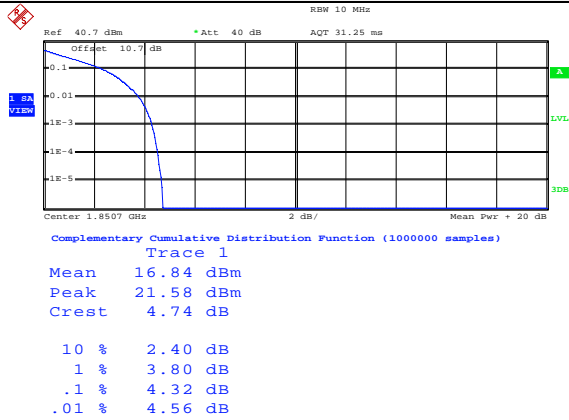

1RB#0

1RB#0

Middle Channel

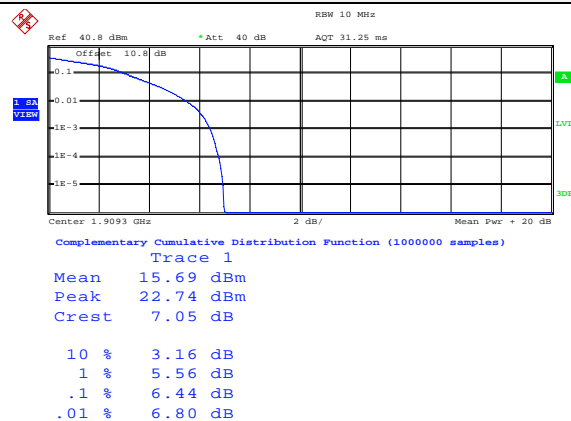
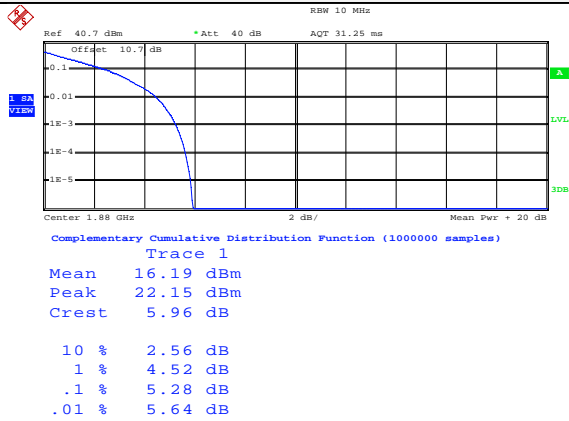

1RB#0

1RB#0

High Channel

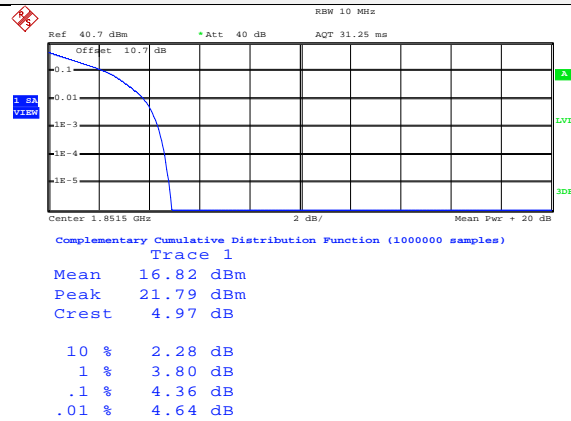
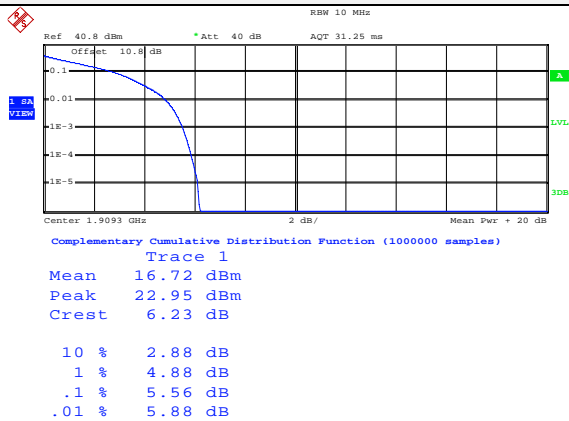

1RB#0

1RB#0



LTE FDD Band 2-3MHz Channel Bandwidth PAPR

QPSK

16QAM

Low Channel

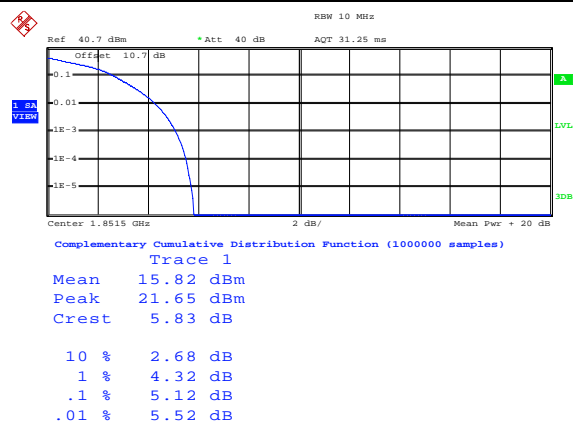
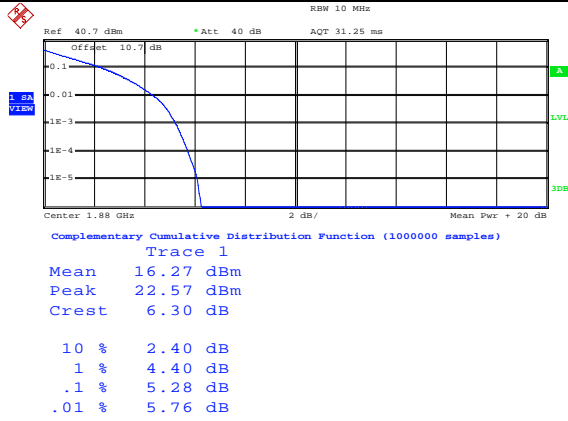

1RB#0

1RB#0

Middle Channel

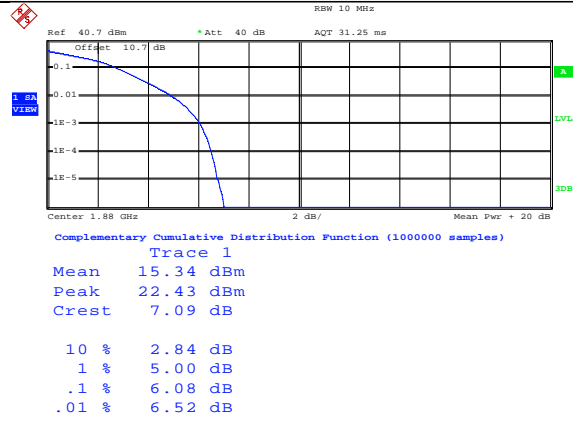
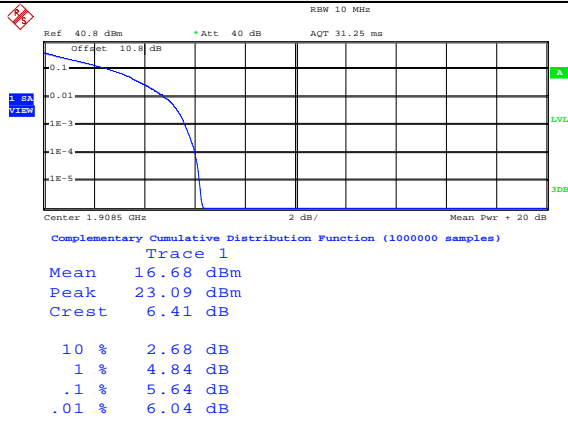

1RB#0

1RB#0

High Channel

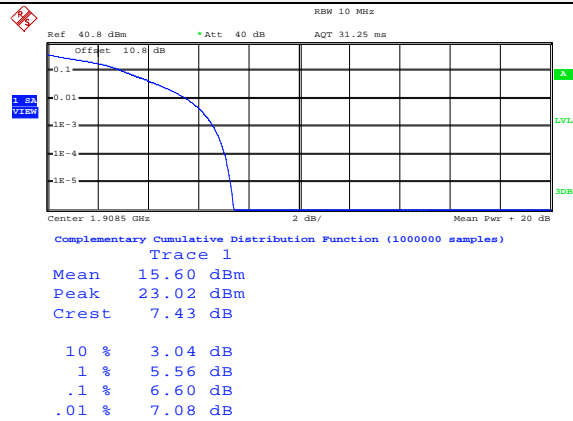
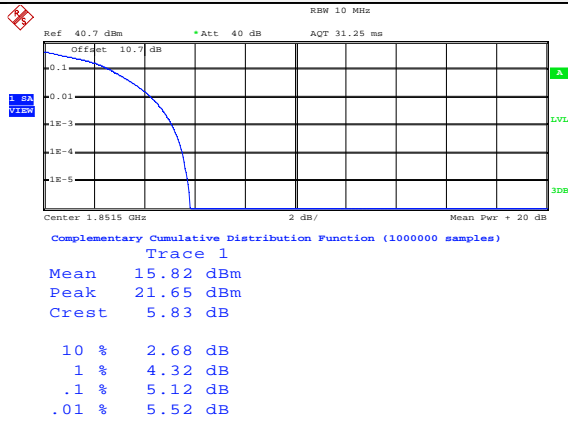

1RB#0

1RB#0



LTE FDD Band 2-5MHz Channel Bandwidth PAPR

QPSK

16QAM

Low Channel

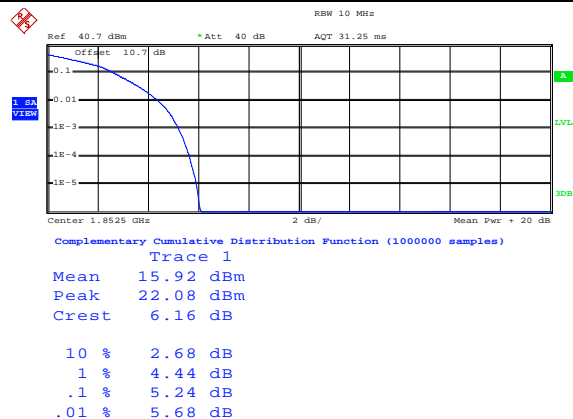
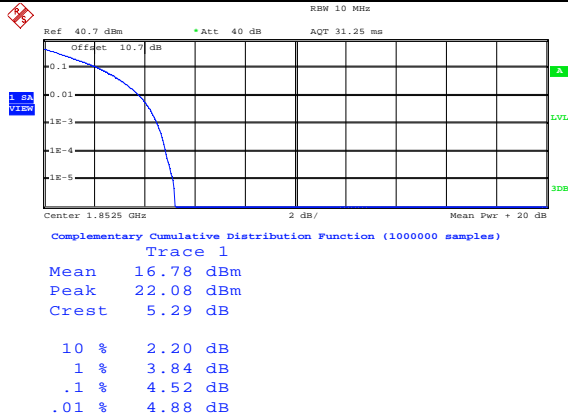

1RB#0

1RB#0

Middle Channel

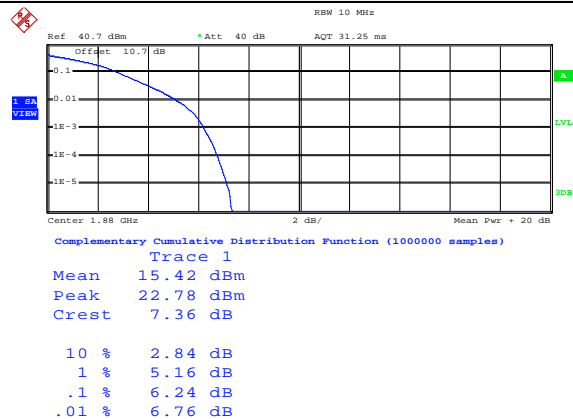
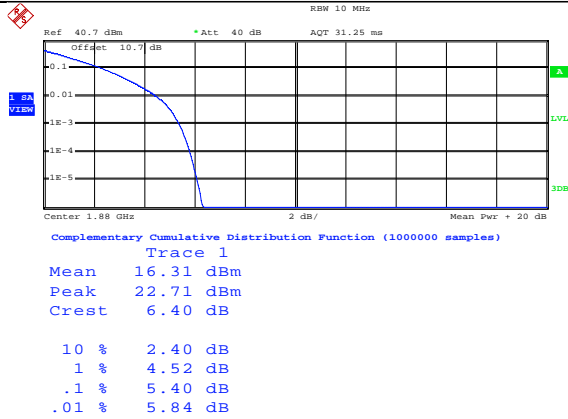

1RB#0

1RB#0

High Channel

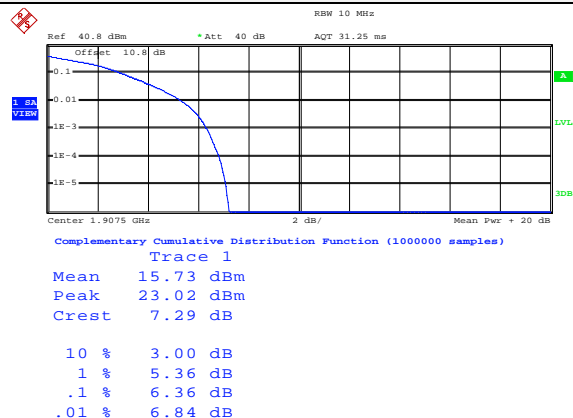
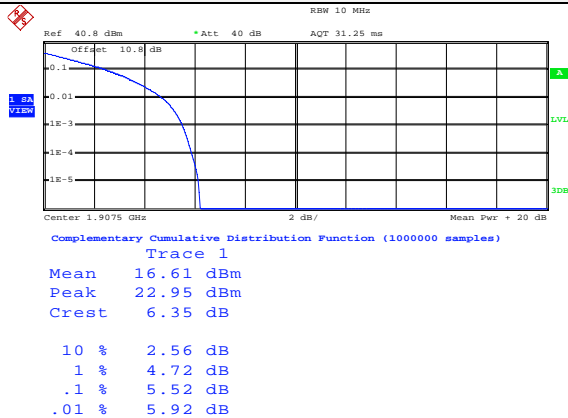

1RB#0

1RB#0



LTE FDD Band 2-10MHz Channel Bandwidth PAPR

QPSK

16QAM

Low Channel

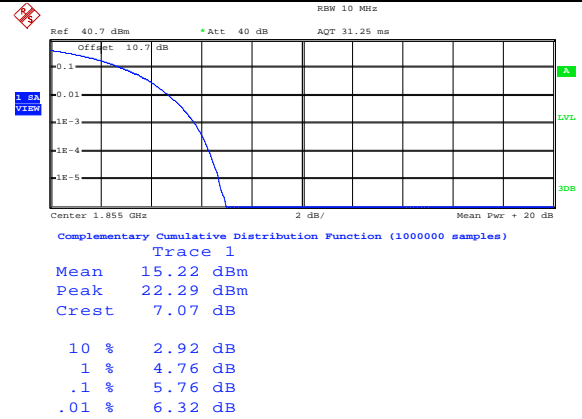
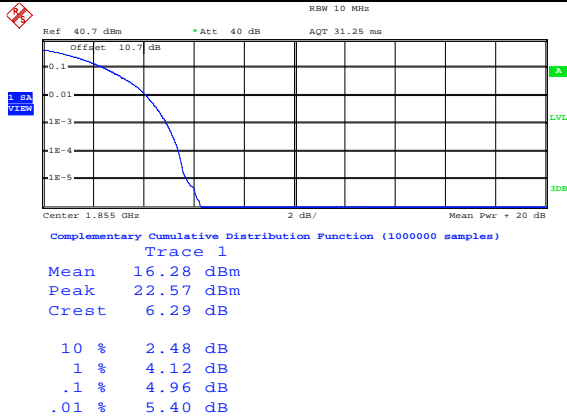

1RB#0

1RB#0

Middle Channel

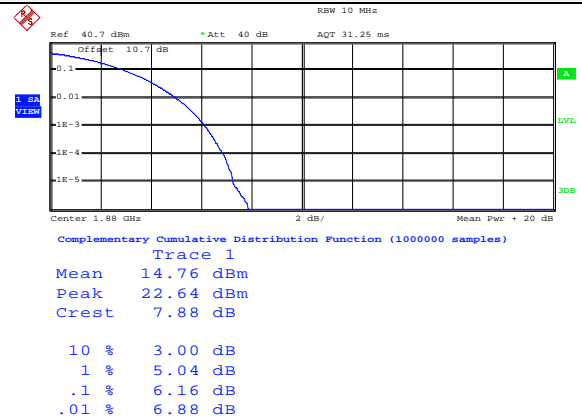
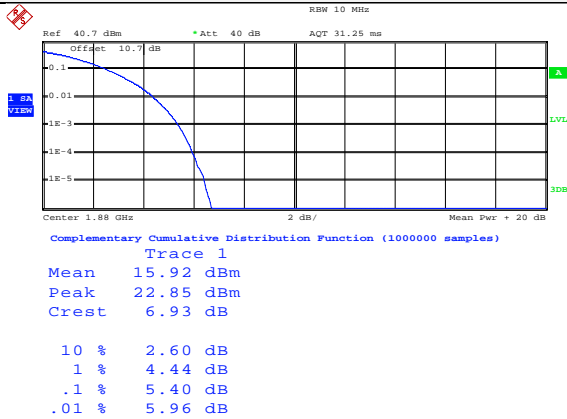

1RB#0

1RB#0

High Channel

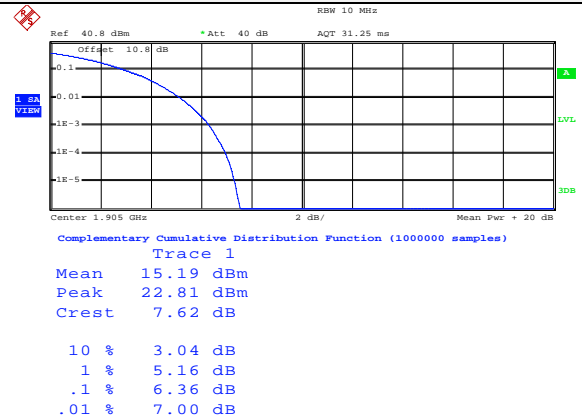
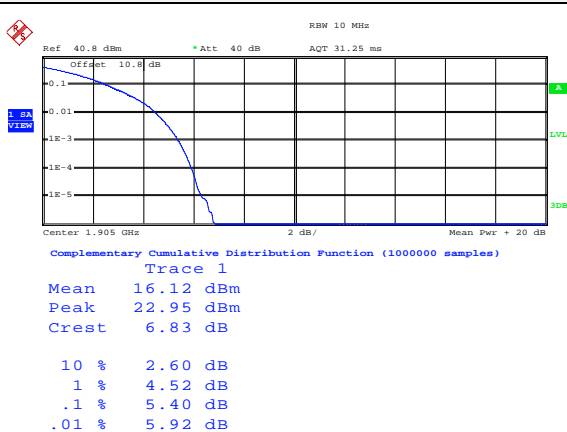

1RB#0

1RB#0



LTE FDD Band 2- 15 MHz Channel Bandwidth PAPR

QPSK

16QAM

Low Channel

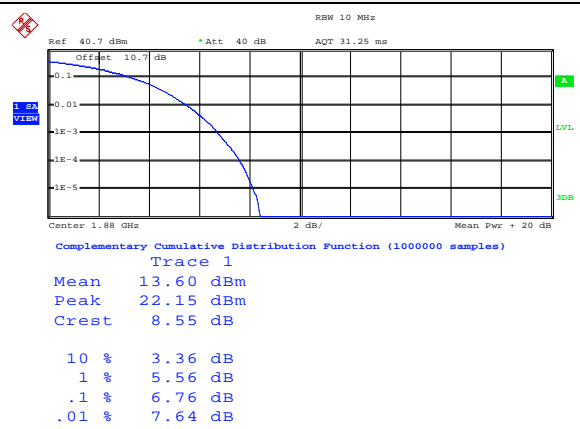
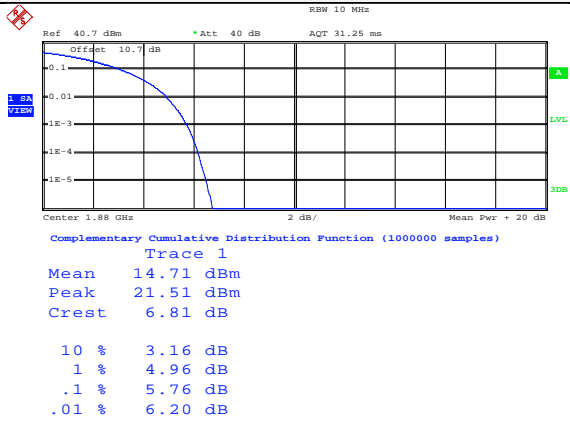

1RB#0

1RB#0

Middle Channel

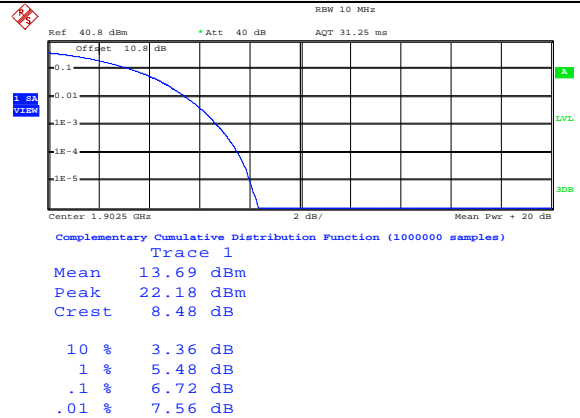
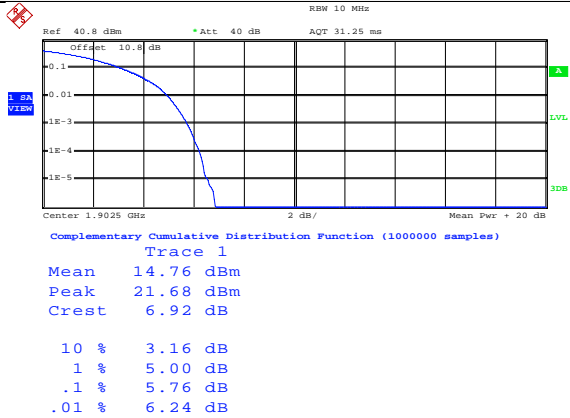

1RB#0

1RB#0

High Channel

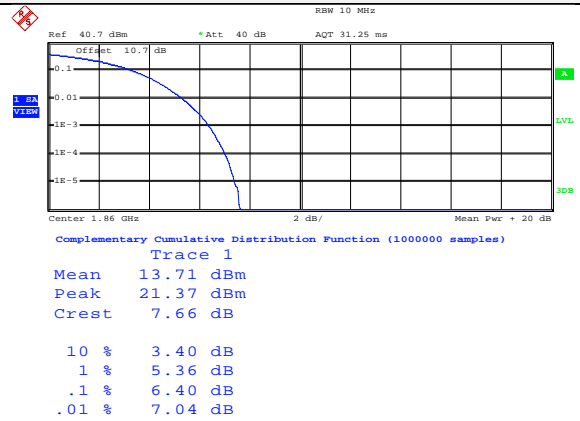
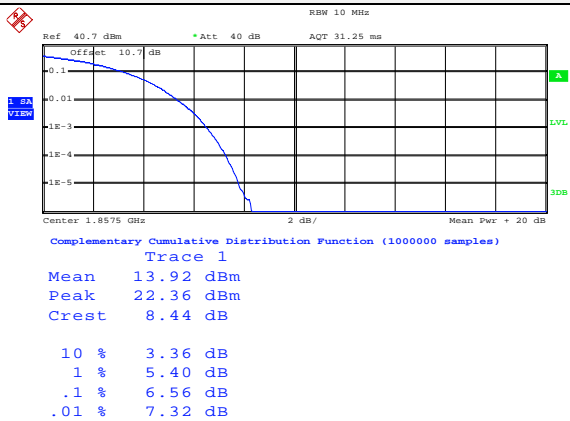

1RB#0

1RB#0



LTE FDD Band 2-20MHz Channel Bandwidth PAPP

QPSK

16QAM

Low Channel

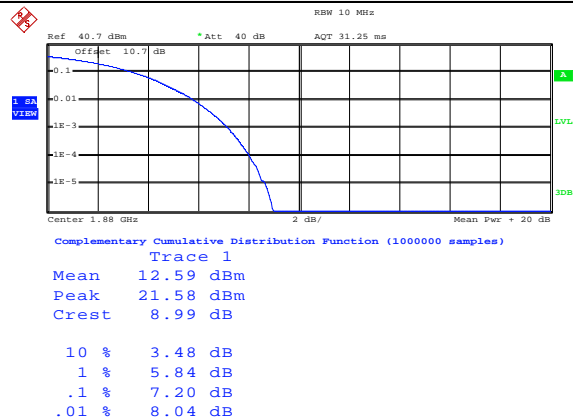
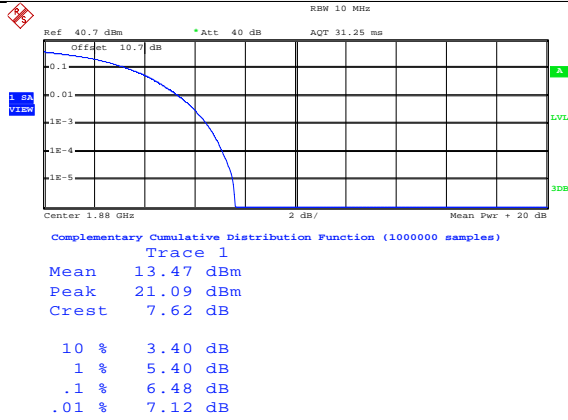

1RB#0

1RB#0

Middle Channel

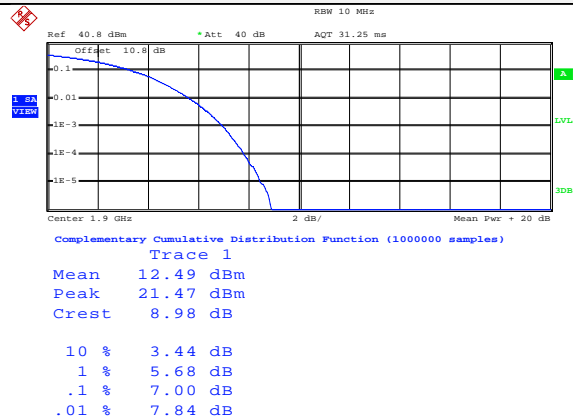
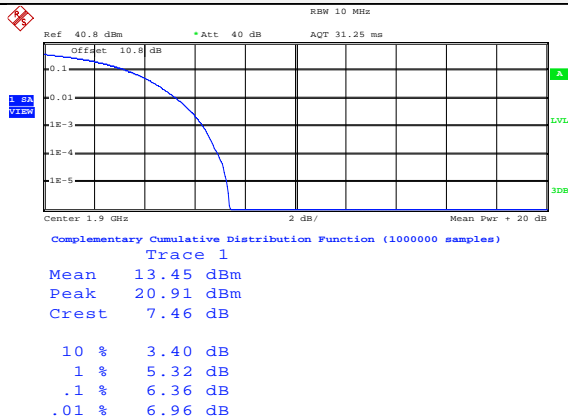

1RB#0

1RB#0

High Channel

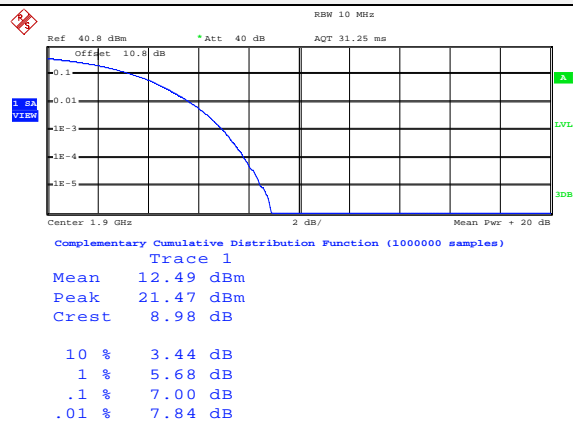
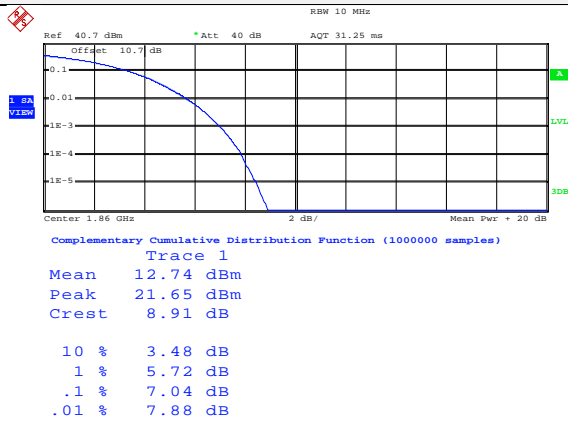

1RB#0

1RB#0



### 4.3 Occupied Bandwidth and Emission Bandwidth

**LIMIT**

N/A

**TEST CONFIGURATION**

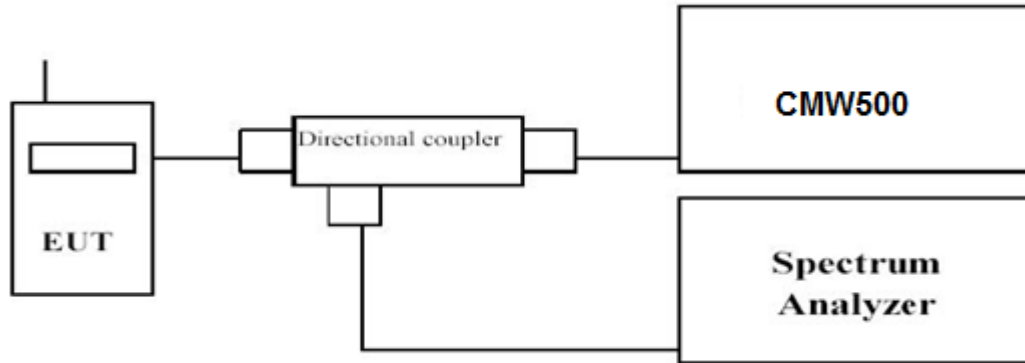

**TEST PROCEDURE**

The transmitter output was connected to a calibrated coaxial cable and coupler, the other end of which was connected to a spectrum analyzer. The occupied bandwidth was measured with the spectrum analyzer at low, middle and high channel in each band. The -26dBc Emission bandwidth was also measured and recorded. Set RBW was set to about 1% of emission BW, VBW ≥ 3 times RBW. -26dBc display line was placed on the screen (or 99% bandwidth), the occupied bandwidth is the delta frequency between the two points where the display line intersects the signal trace.

**TEST RESULTS**

Remark:

1. We were tested all RB Configuration refer 3GPP TS136 521 for each Channel Bandwidth of LTE FDD Band 2; recorded worst case for each Channel Bandwidth of LTE FDD Band 2.

LTE FDD Band 2						
TX Channel Bandwidth	RB Size/Offset	Frequency (MHz)	-26dBc Emission bandwidth (MHz)		99% Occupied bandwidth (MHz)	
			QPSK	16QAM	QPSK	16QAM
1.4 MHz	6RB#0	1850.7	1.315	1.375	1.095	1.095
		1880.0	1.250	1.250	1.085	1.090
		1909.3	1.260	1.245	1.090	1.090
3 MHz	15RB#0	1851.5	3.060	2.970	2.69	2.69
		1880.0	2.880	2.880	2.68	2.69
		1908.5	2.890	2.870	2.68	2.68
5 MHz	25RB#0	1852.5	4.970	4.790	4.49	4.51
		1880.0	4.790	4.780	4.5	4.49
		1907.5	4.810	4.770	4.5	4.5
10 MHz	50RB#0	1855.0	9.700	9.433	8.933	8.933
		1880.0	9.300	9.300	8.9	8.933
		1905.0	9.333	9.333	8.933	13.55
15 MHz	75RB#0	1857.5	14.700	14.600	13.55	13.5
		1880.0	14.550	14.600	13.45	13.45
		1902.5	14.600	14.600	13.5	13.5
20 MHz	100RB#0	1860.0	19.200	19.067	18	17.867
		1880.0	19.133	19.067	17.933	17.933
		1900.0	19.133	19.067	17.933	17.933



LTE FDD Band 2 – 1.4 MHz Channel Bandwidth Occupied Bandwidth and Emission Bandwidth

QPSK

16QAM

Low Channel

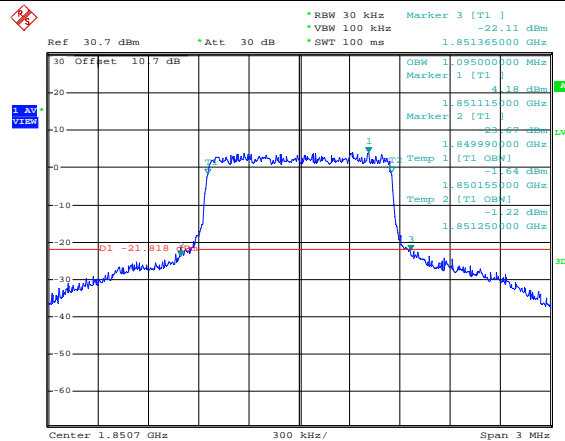
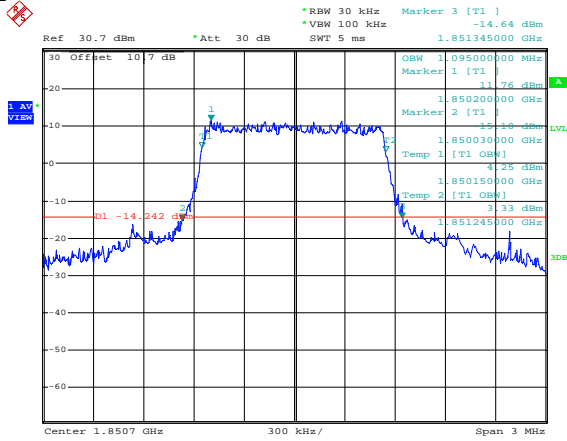

6RB#0

6RB#0

Middle Channel

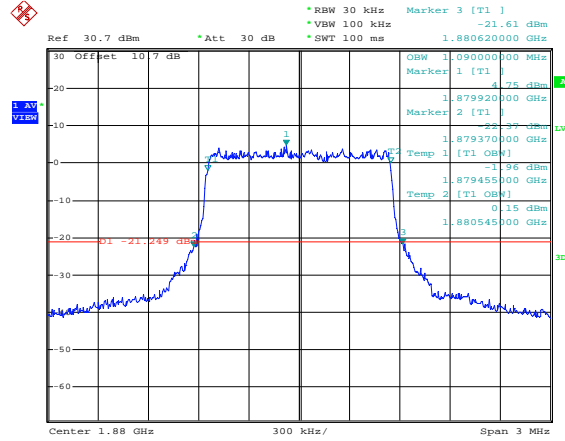
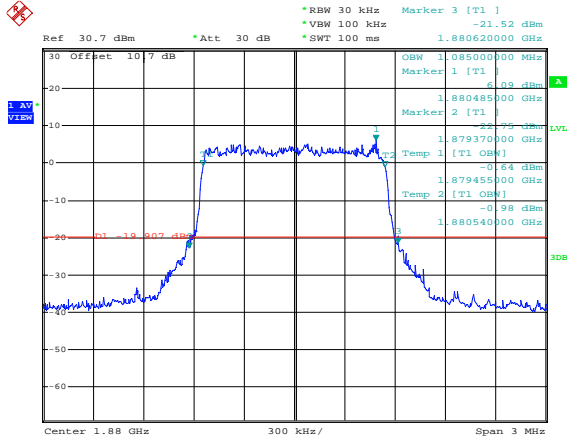

6RB#0

6RB#0

High Channel

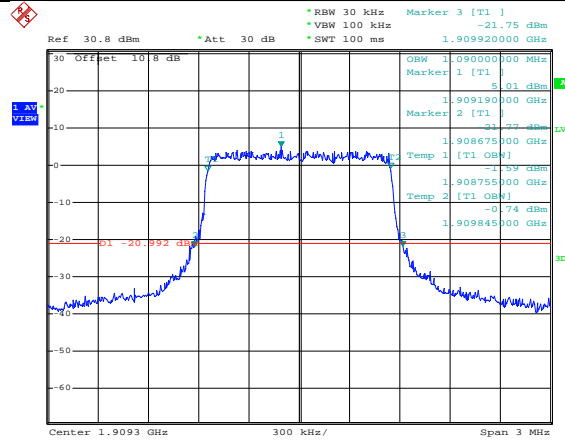
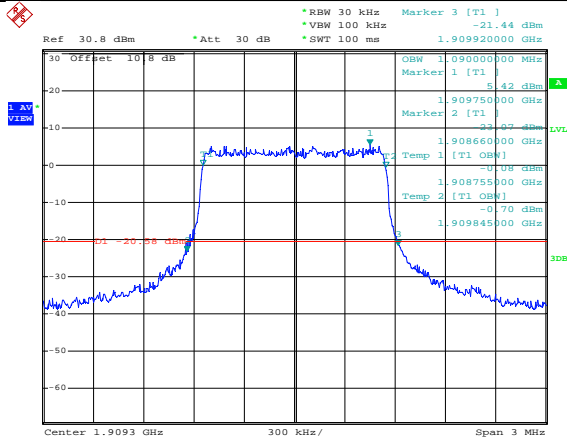

6RB#0

6RB#0





### LTE FDD Band 2-3MHz Channel Bandwidth Occupied Bandwidth and Emission Bandwidth

QPSK

16QAM

#### Low Channel

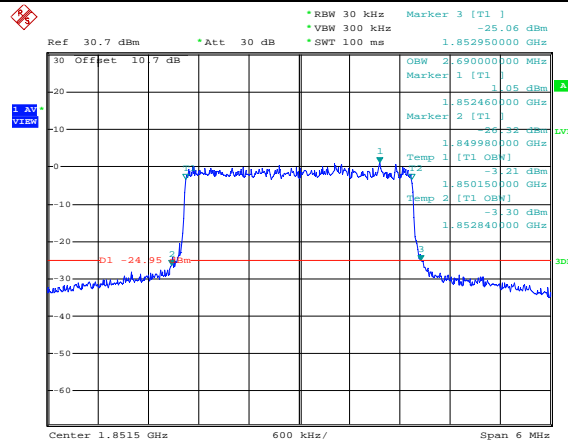
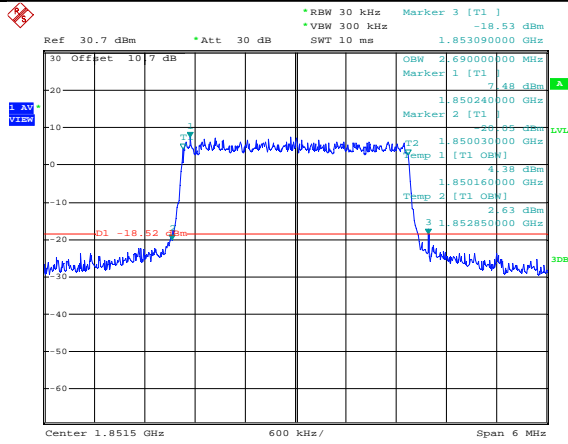

15RB#0

15RB#0

#### Middle Channel

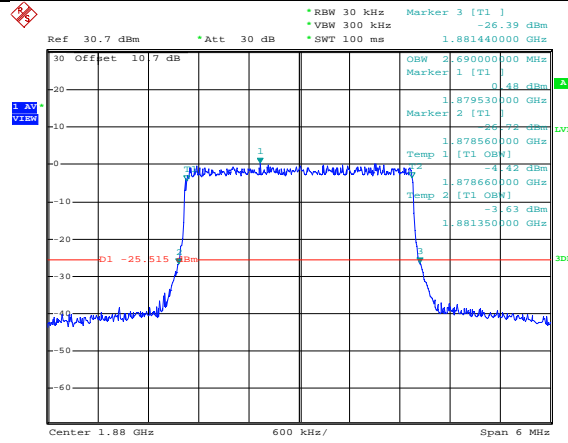
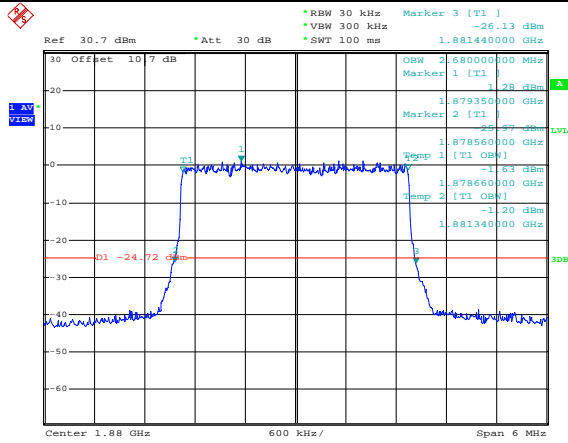

15RB#0

15RB#0

#### High Channel

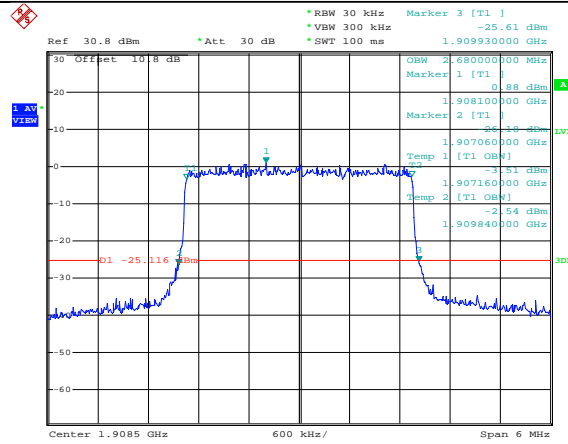
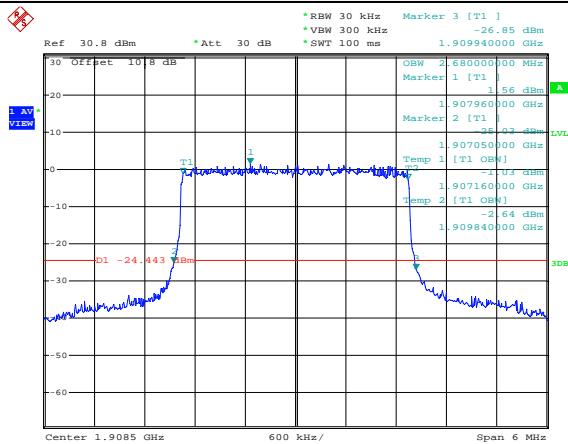

15RB#0

15RB#0



LTE FDD Band 2-5MHz Channel Bandwidth Occupied Bandwidth and Emission Bandwidth

QPSK

16QAM

Low Channel

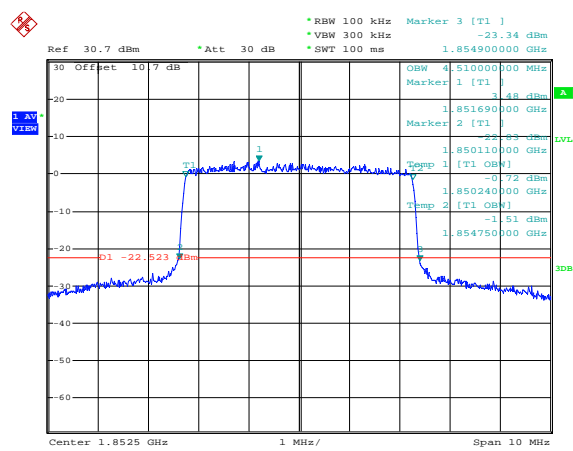
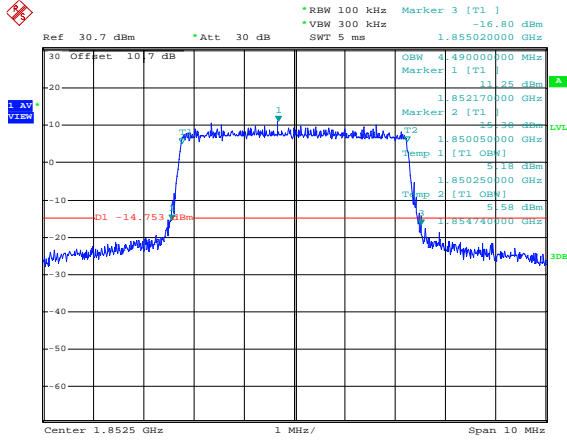

25RB#0

25RB#0

Middle Channel

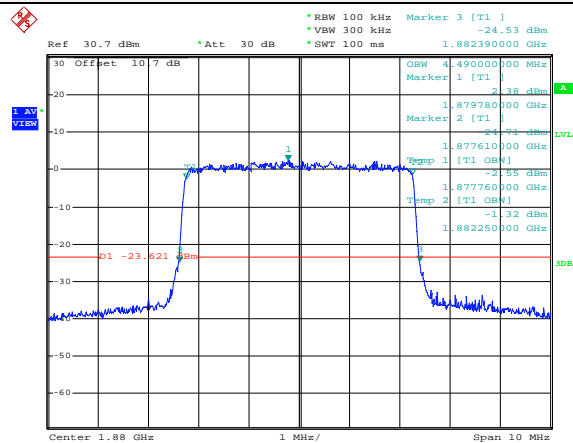
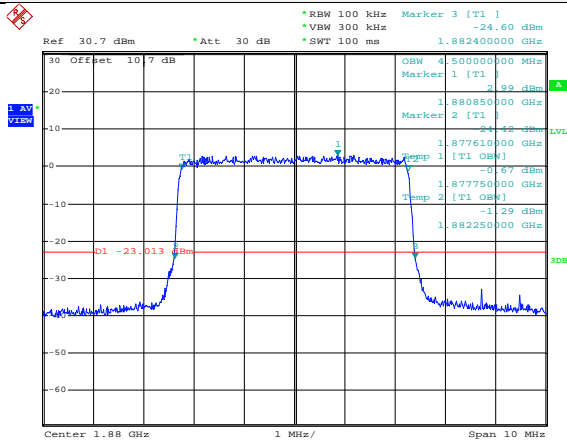

25RB#0

25RB#0

High Channel

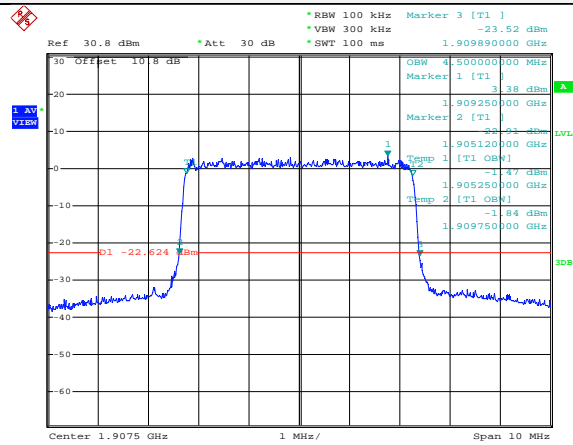
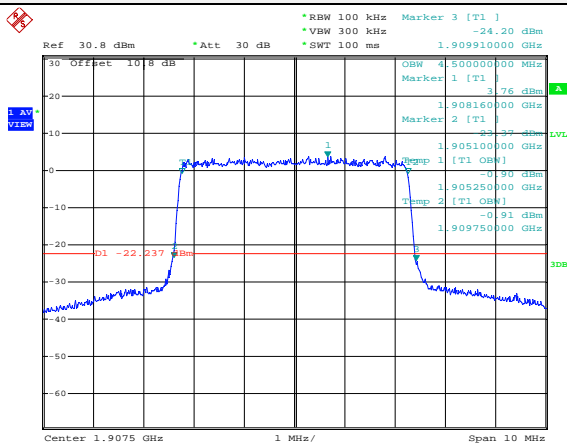

25RB#0

25RB#0

LTE FDD Band 2-10MHz Channel Bandwidth Occupied Bandwidth and Emission Bandwidth

QPSK

16QAM

Low Channel

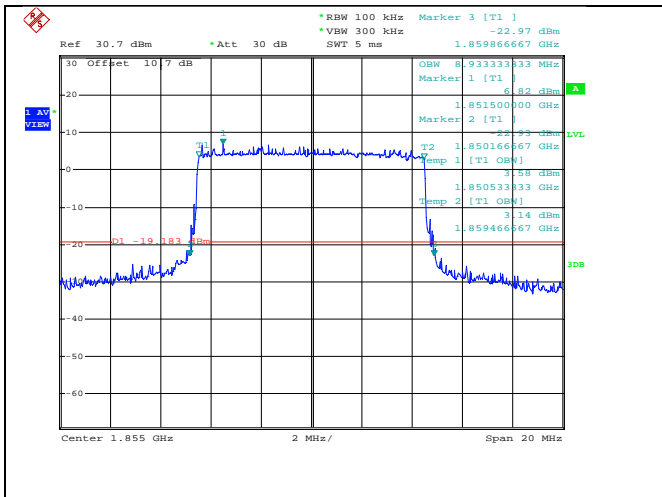

50RB#0

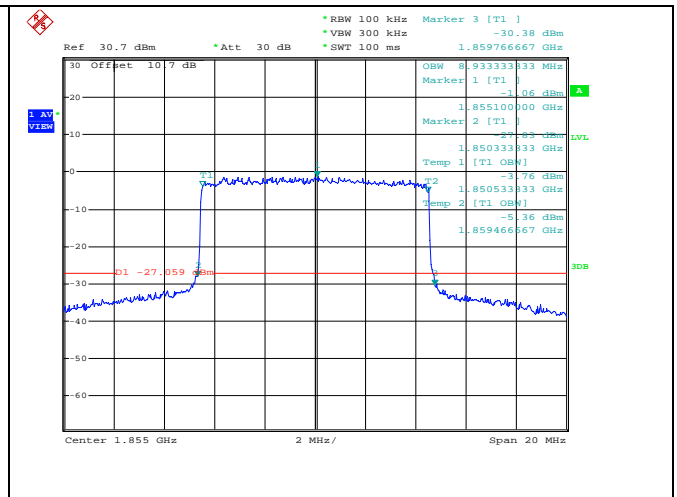

50RB#0

Middle Channel

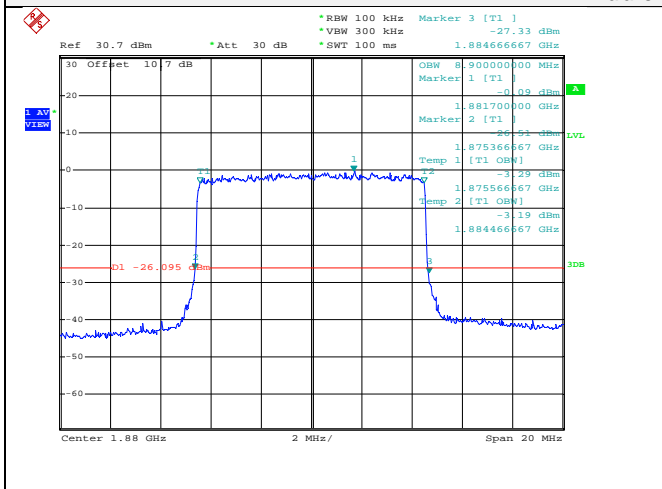

50RB#0

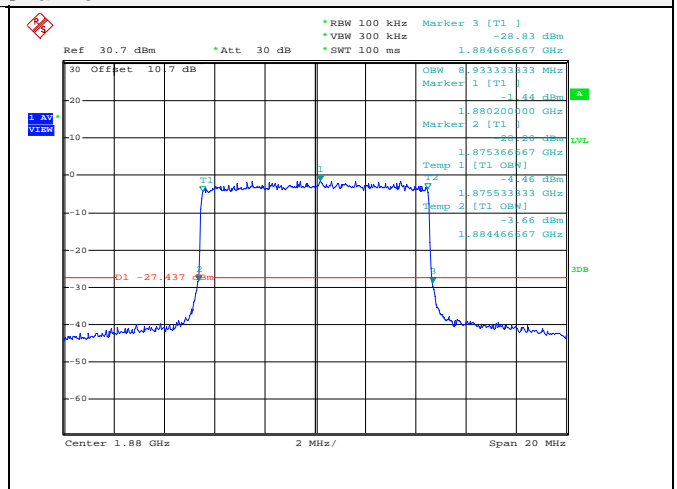

50RB#0

High Channel

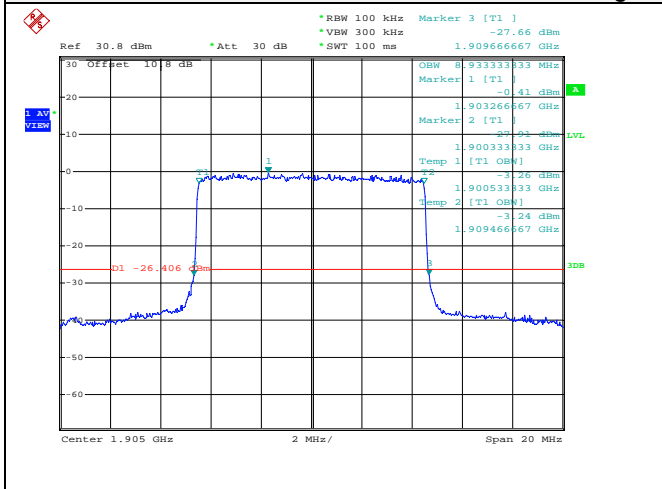

50RB#0

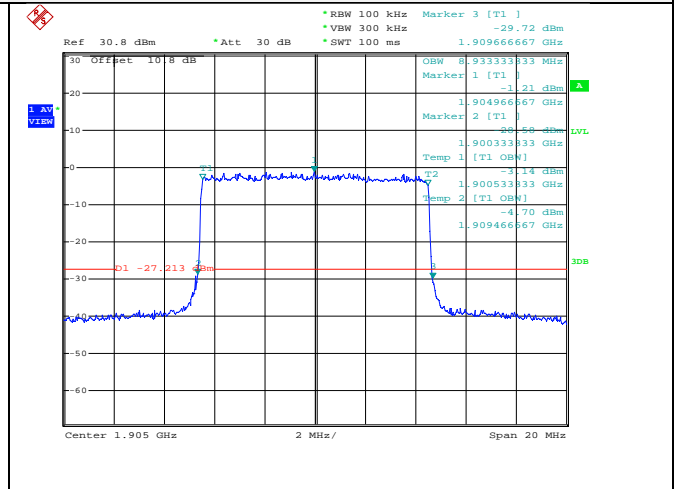

50RB#0



### LTE FDD Band 2-15MHz Channel Bandwidth Occupied Bandwidth and Emission Bandwidth

QPSK

16QAM

#### Low Channel

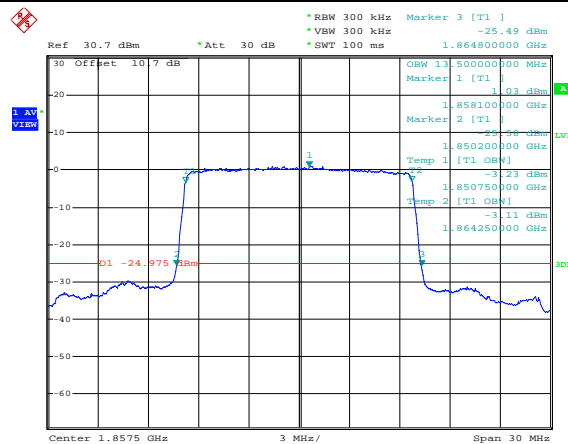
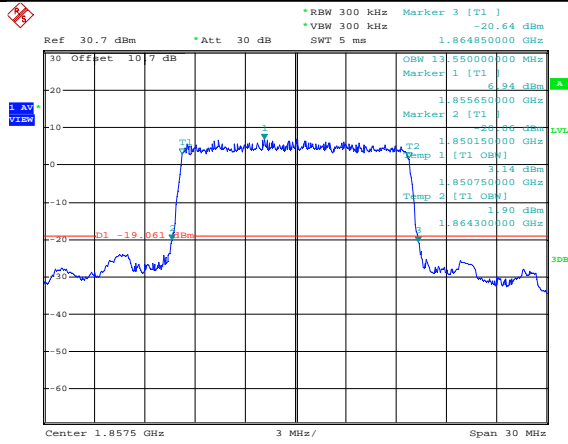

75RB#0

75RB#0

#### Middle Channel

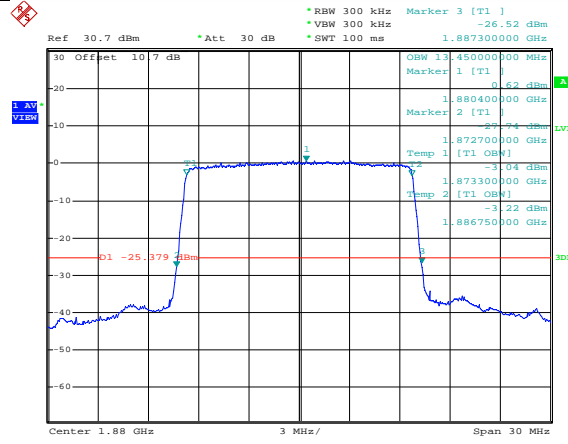
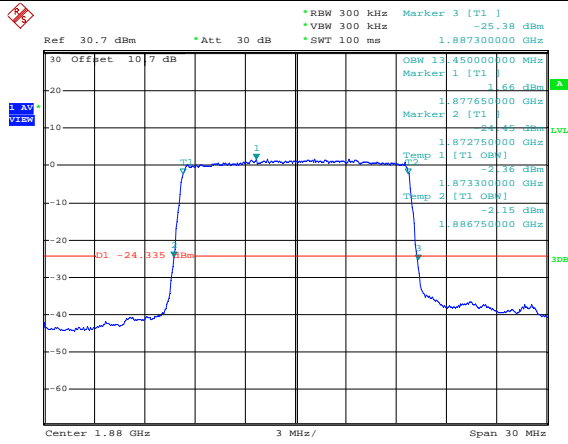

75RB#0

75RB#0

#### High Channel

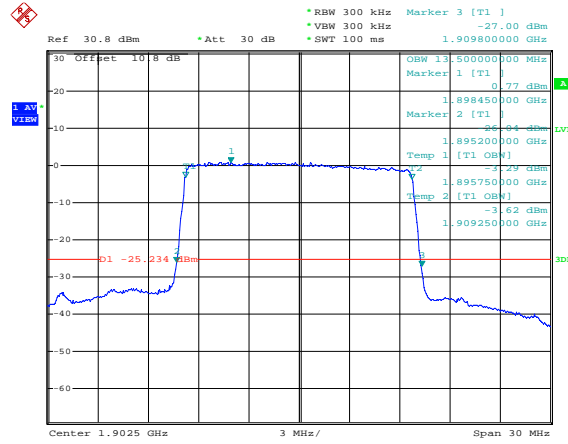
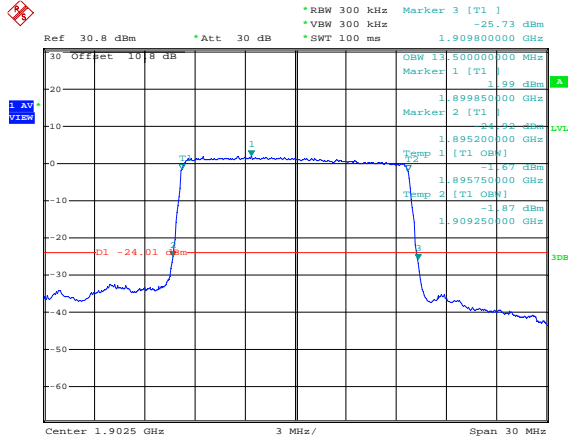

75RB#0

75RB#0



LTE FDD Band 2-20MHz Channel Bandwidth Occupied Bandwidth and Emission Bandwidth

QPSK

16QAM

Low Channel

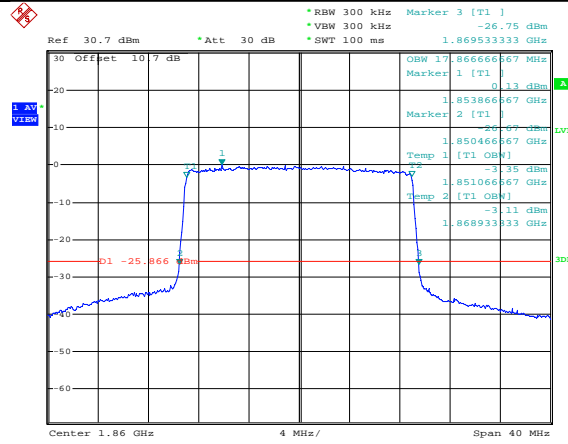
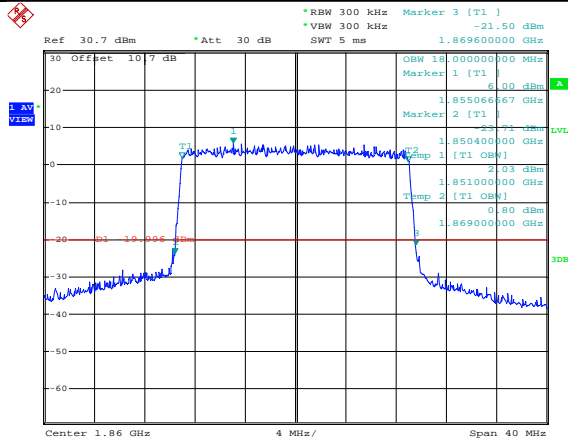

100RB#0

100RB#0

Middle Channel

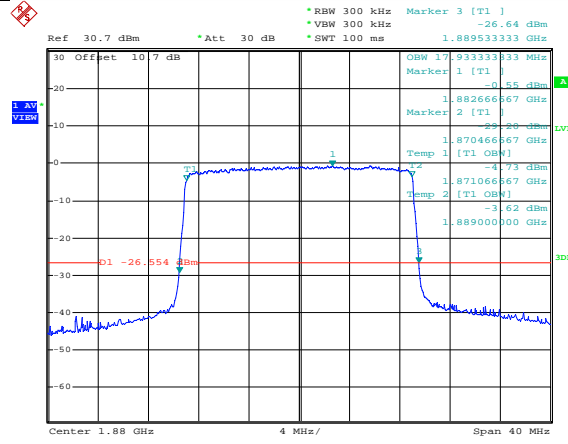
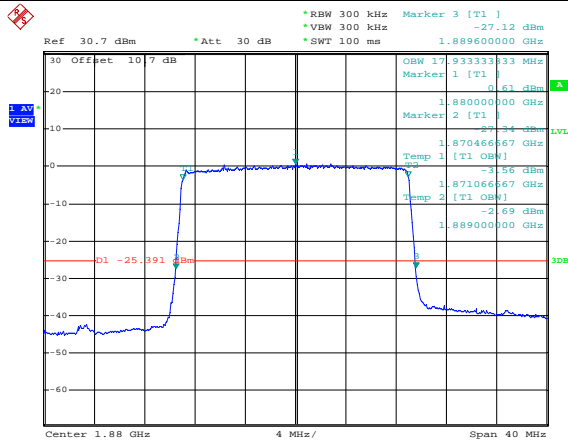

100RB#0

100RB#0

High Channel

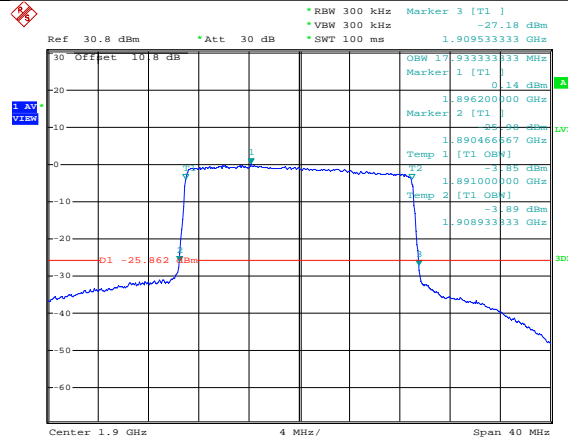
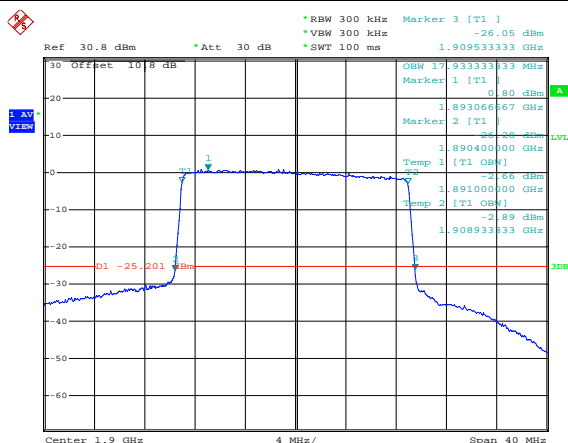

100RB#0

100RB#0



## 4.4 Band Edge compliance

### LIMIT

Per FCC §24.238 the power of any emission outside of the authorized operating frequency ranges must be attenuated below the transmitting power (P) by a factor of at least  $43 + 10\log(P)$  dB.

### TEST CONFIGURATION

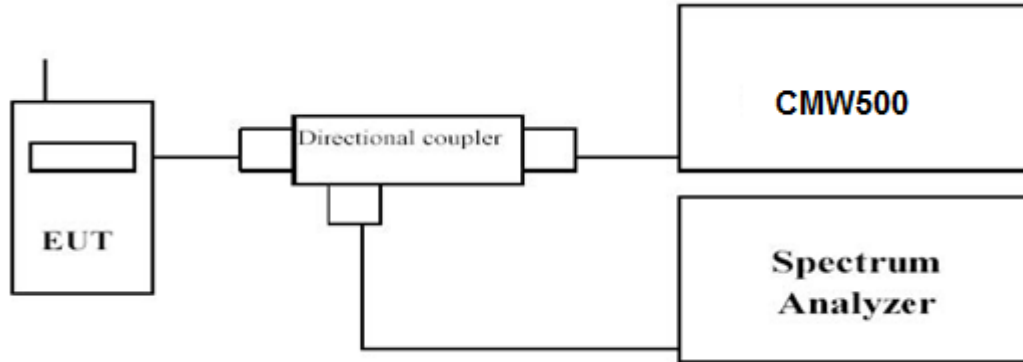

### TEST PROCEDURE

1. The transmitter output port was connected to base station.
2. The RF output of EUT was connected to the power meter by RF cable and attenuator, the path loss was compensated to the results for each measurement.
3. Set EUT at maximum power through base station.
4. Select lowest and highest channels for each band and different modulation.
5. Measure Band edge using RMS (Average) detector by spectrum

### TEST RESULTS

Remark:

1. We were tested all RB Configuration refer 3GPP TS136 521 for each Channel Bandwidth of LTE FDD Band 2; recorded worst case for each Channel Bandwidth of LTE FDD Band 2.

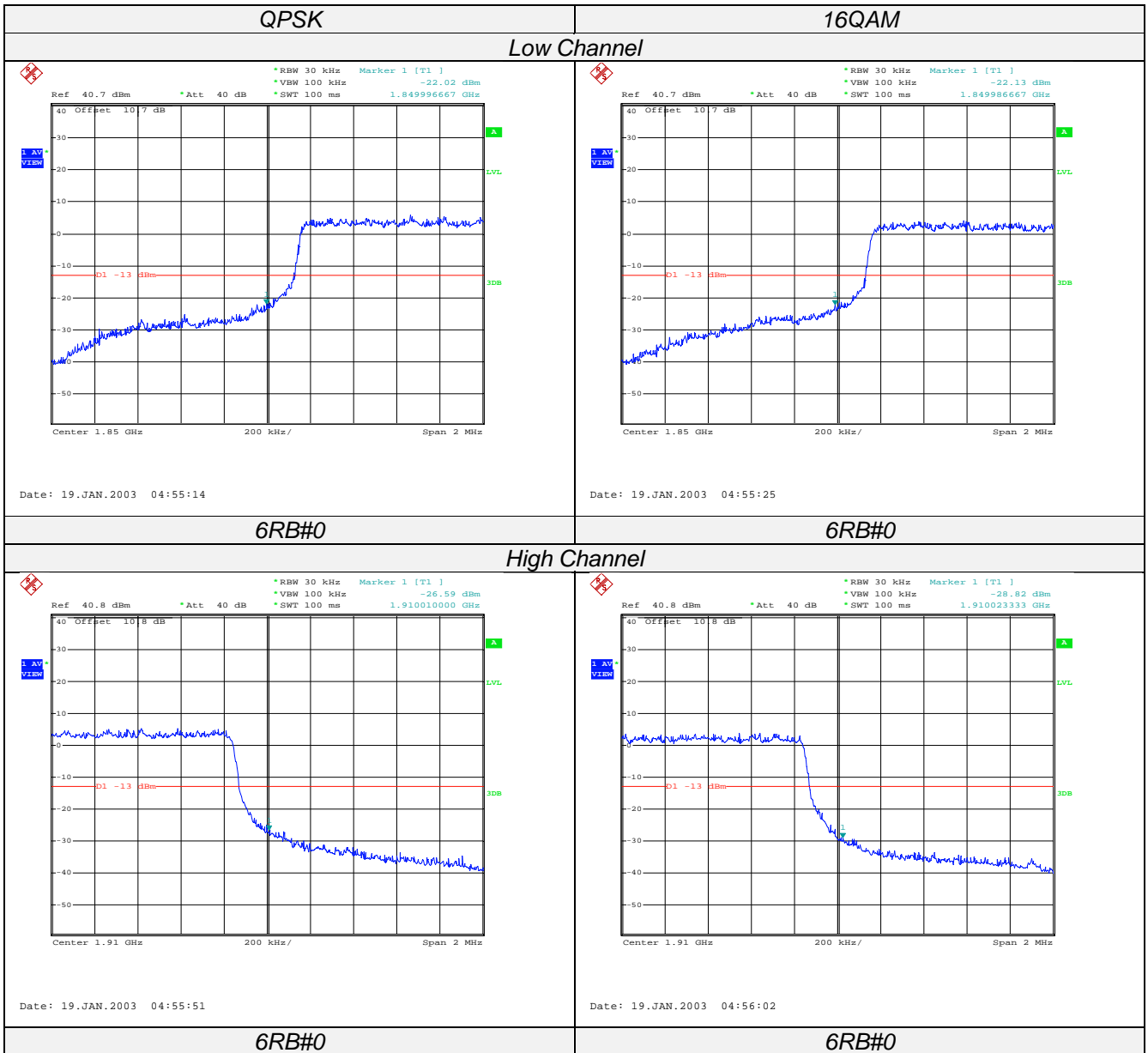



LTE FDD Band 2-3MHz Channel Bandwidth Band Edge Compliance

QPSK

16QAM

Low Channel

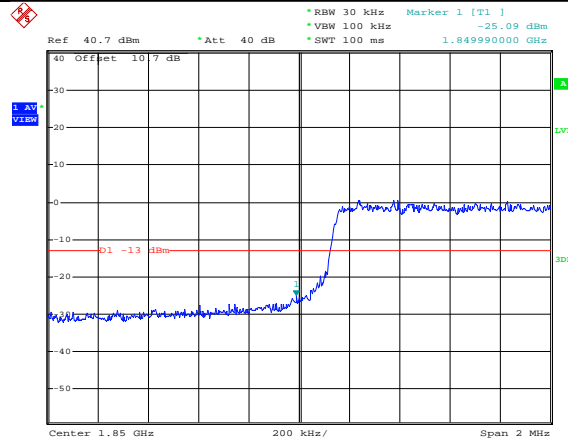
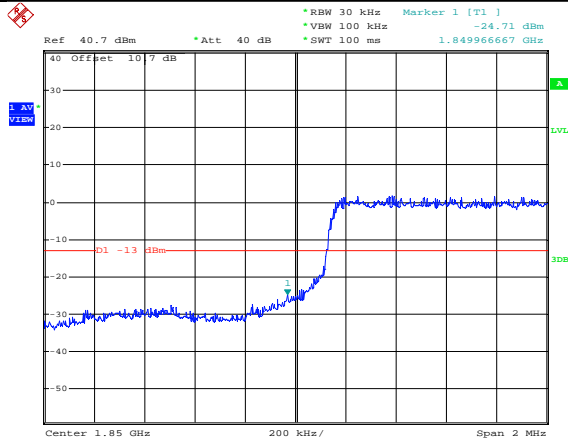

Date: 19.JAN.2003 05:23:16

Date: 19.JAN.2003 05:23:28

15RB#0

15RB#0

High Channel

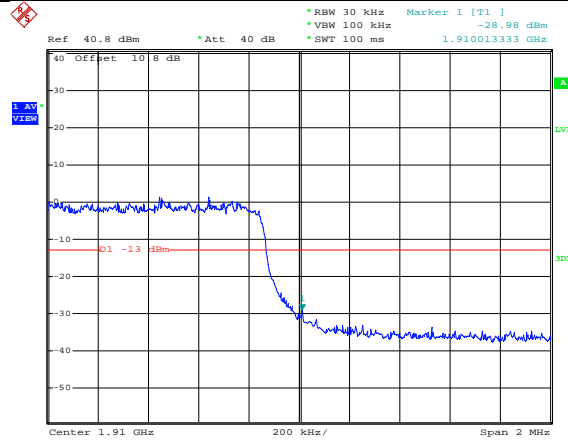
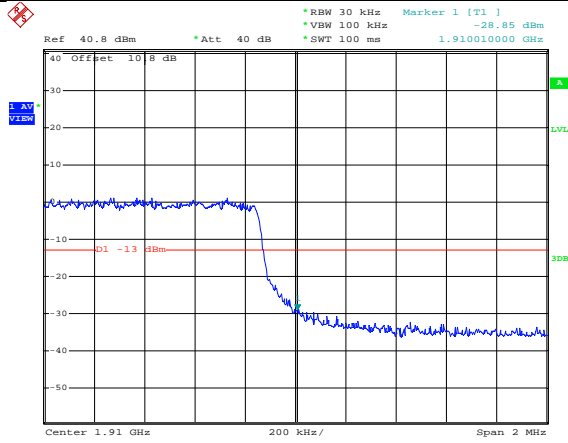

Date: 19.JAN.2003 05:23:54

Date: 19.JAN.2003 05:24:05

15RB#0

15RB#0





LTE FDD Band 2-5MHz Channel Bandwidth Band Edge Compliance

QPSK

16QAM

Low Channel

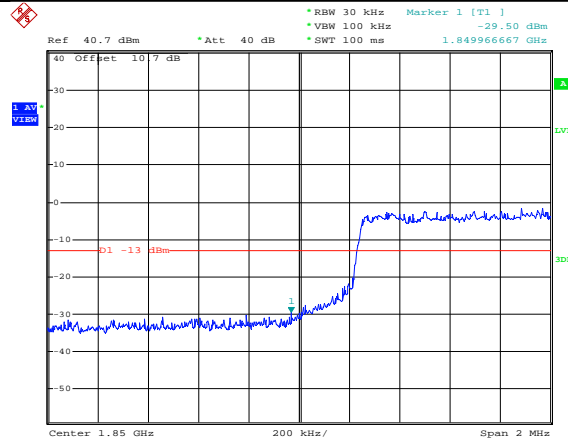
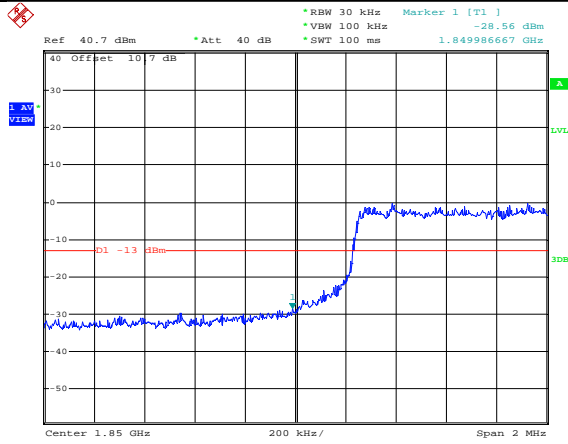

Date: 19.JAN.2003 06:17:08

Date: 19.JAN.2003 06:17:20

25RB#0

25RB#0

High Channel

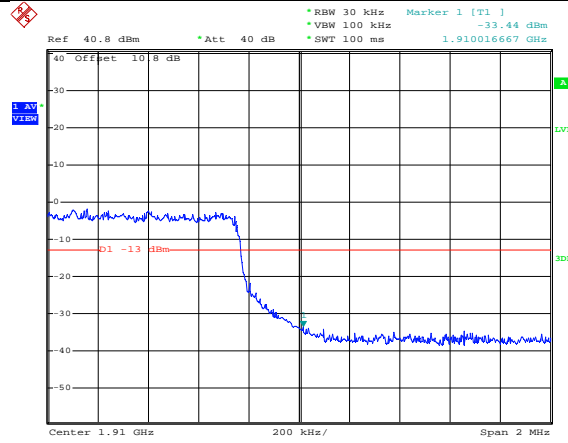
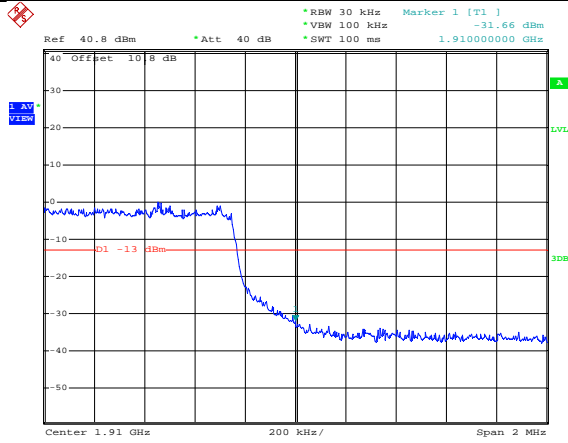

Date: 19.JAN.2003 06:17:45

Date: 19.JAN.2003 06:17:56

25RB#0

25RB#0



LTE FDD Band 2 – 10 MHz Channel Bandwidth Band Edge Compliance

QPSK

16QAM

Low Channel

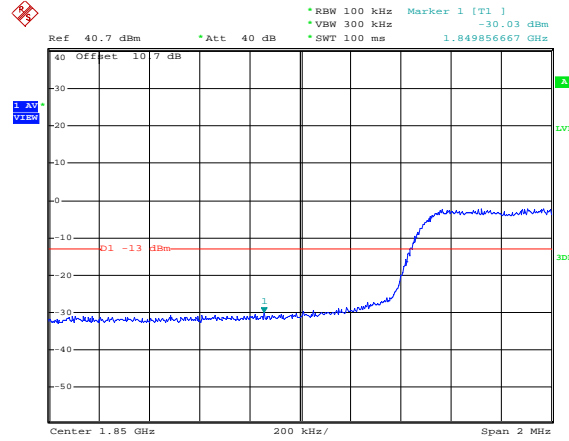
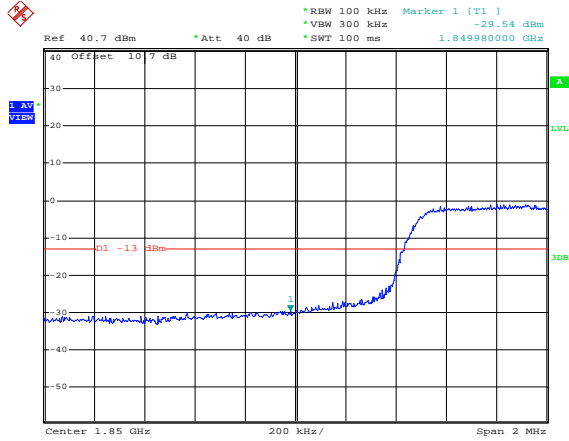

Date: 19.JAN.2003 06:43:53

Date: 19.JAN.2003 06:44:05

50RB#0

50RB#0

High Channel

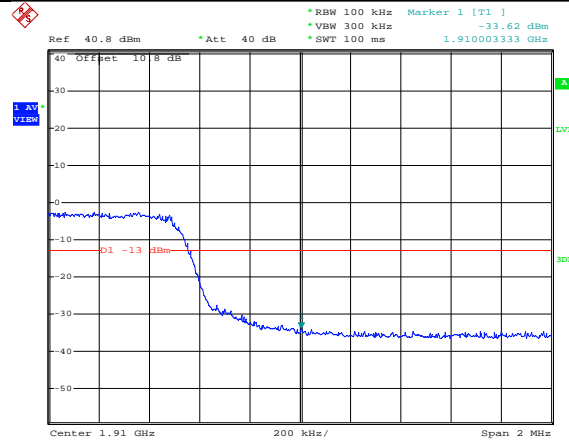
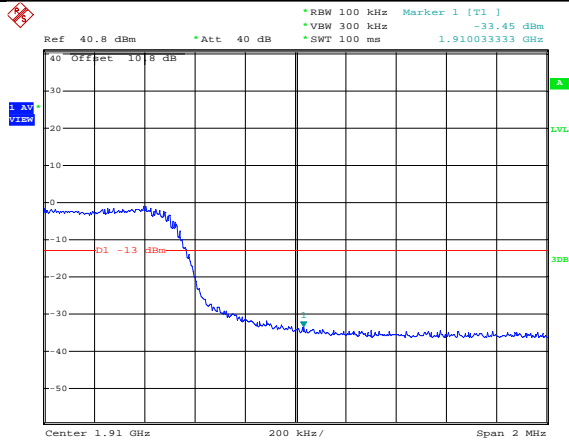

Date: 19.JAN.2003 06:44:32

Date: 19.JAN.2003 06:44:44

50RB#0

50RB#0



LTE FDD Band 2-15MHz Channel Bandwidth Band Edge Compliance

QPSK

16QAM

Low Channel

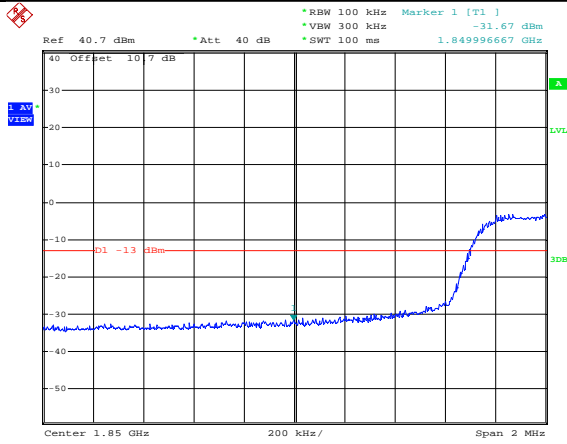

Date: 19.JAN.2003 07:12:44

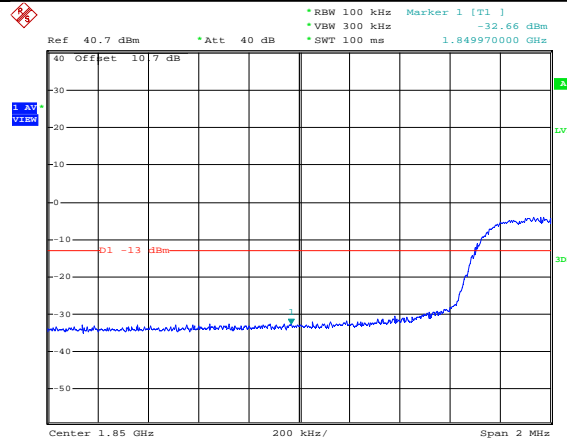

Date: 19.JAN.2003 07:12:56

75RB#0

75RB#0

High Channel

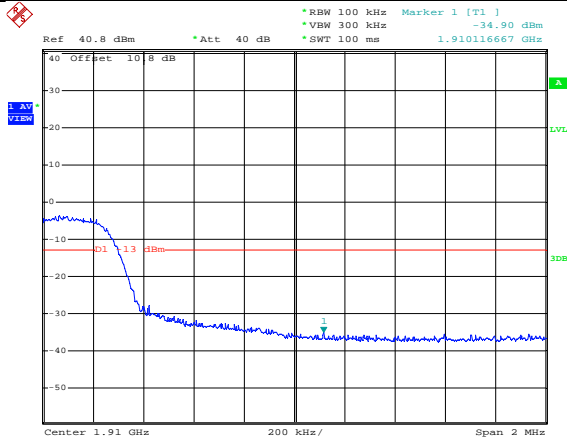

Date: 19.JAN.2003 07:13:28

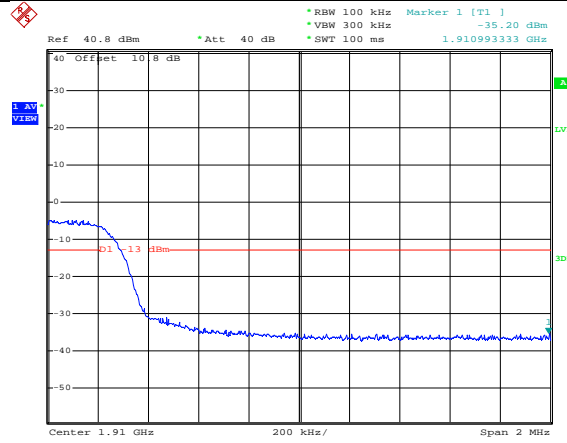

Date: 19.JAN.2003 07:13:40

75RB#0

75RB#0



LTE FDD Band 2-20MHz Channel Bandwidth Band Edge Compliance

QPSK

16QAM

Low Channel

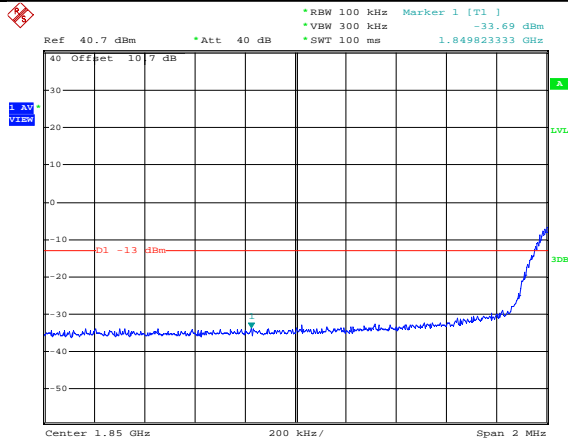

Date: 19.JAN.2003 07:45:38

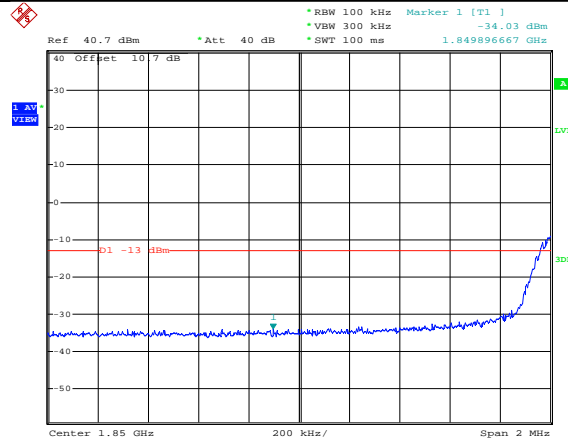

Date: 19.JAN.2003 07:45:52

100RB#0

100RB#0

High Channel

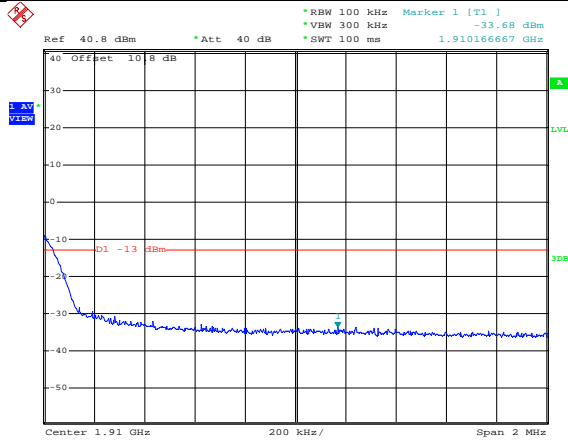

Date: 19.JAN.2003 07:46:19

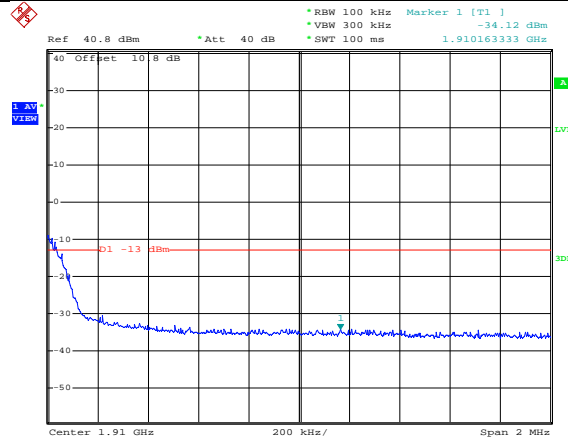

Date: 19.JAN.2003 07:46:32

100RB#0

100RB#0



### 4.5 Spurious Emission on Antenna Port

#### LIMIT

Per FCC §24.238, the power of any emission outside of the authorized operating frequency ranges must be attenuated below the transmitting power (P) by a factor of at least  $43 + 10\log(P)$  dB.

#### TEST CONFIGURATION

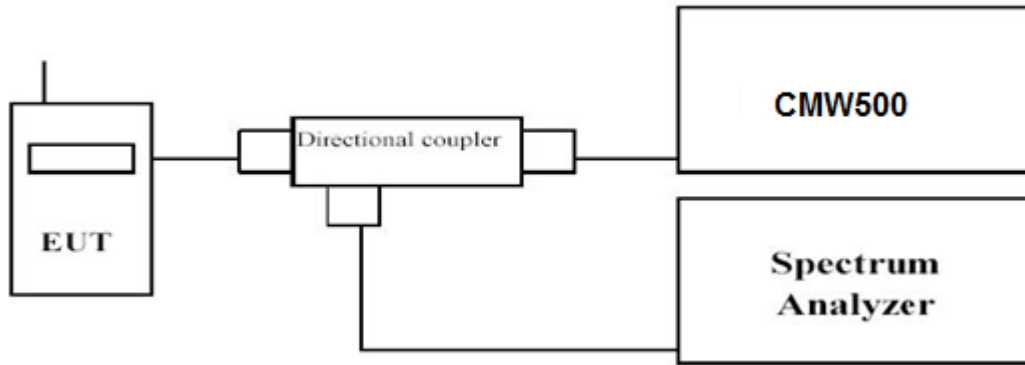

#### TEST PROCEDURE

The EUT was setup according to EIA/TIA 603D

- a. Place the EUT on a bench and set it in transmitting mode.
- b. Connect a low loss RF cable from the antenna port to a spectrum analyzer and CMW500 by a Directional Coupler.
- c. EUT Communicate with CMW500, then select a channel for testing.
- d. Add a correction factor to the display of spectrum, and then test.
- e. The resolution bandwidth of the spectrum analyzer was set sufficient scans were taken to show the out of band Emission if any up to 10<sup>th</sup> harmonic.
- f. Please refer to following tables for test antenna conducted emissions.

Working Frequency	Sub range (GHz)	RBW	VBW	Sweep time (s)
LTE FDD Band 2	0.01~20	1 MHz	3 MHz	Auto

#### TEST RESULTS

Remark:

1. We were tested all RB Configuration refer 3GPP TS136 521 for each Channel Bandwidth of LTE FDD Band 2; recorded worst case at the QPSK Mode for each Channel Bandwidth of LTE FDD Band 2



LTE FDD Band 2-1.4MHz Channel Bandwidth

Low Channel

QPSK

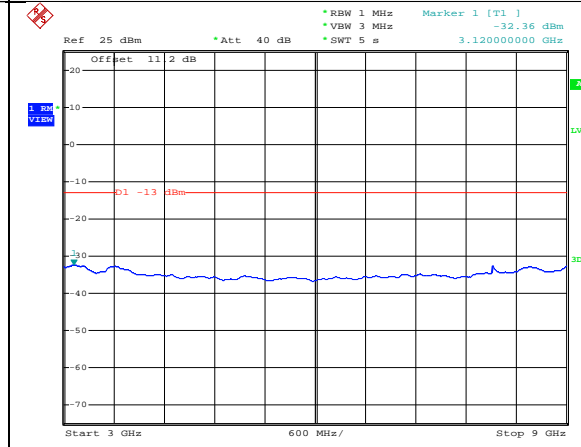
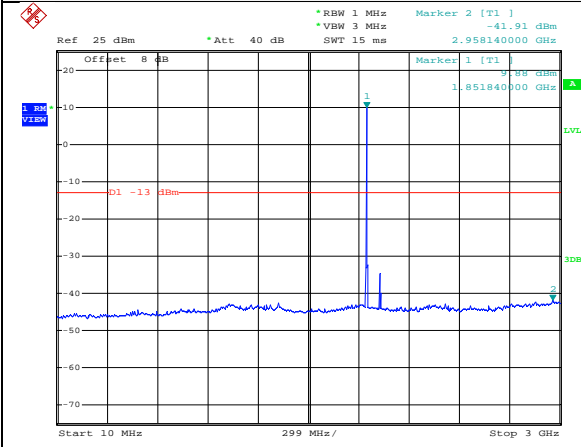

10MHz~3GHz

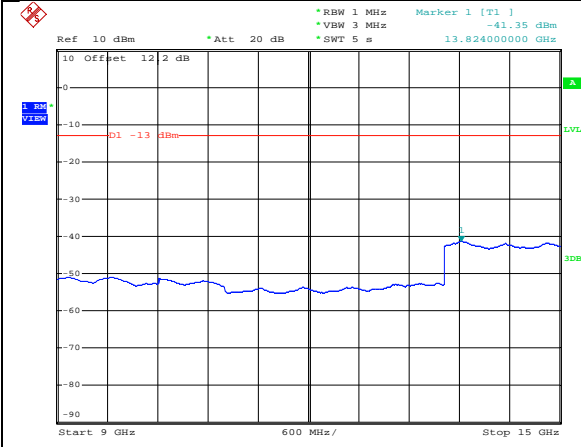

3GHz~9GHz

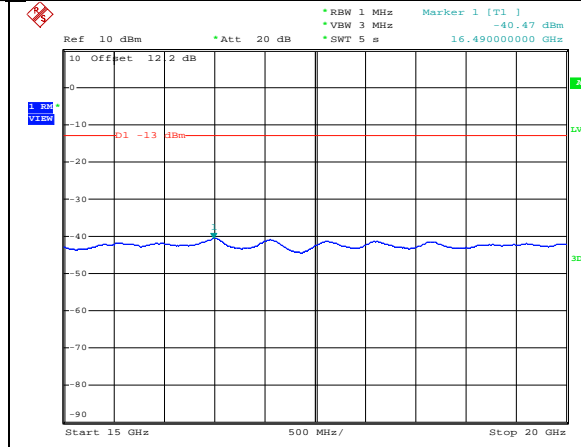

9 GHz~15 GHz

15 GHz~20GHz



LTE FDD Band 2-1.4MHz Channel Bandwidth

Middle Channel

QPSK

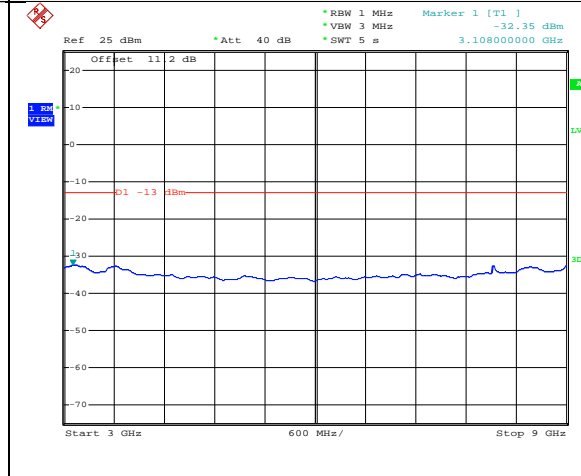
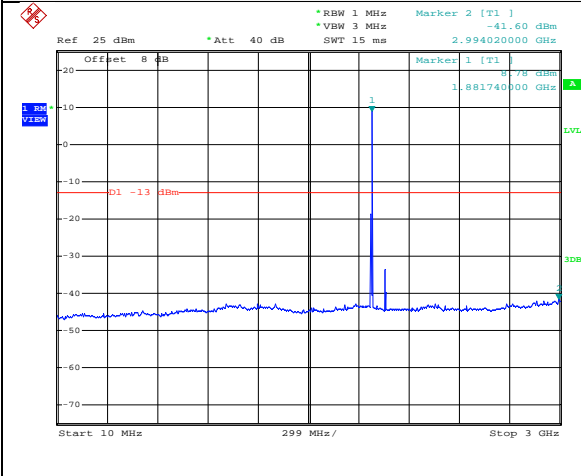

10MHz~3GHz

3GHz~9GHz

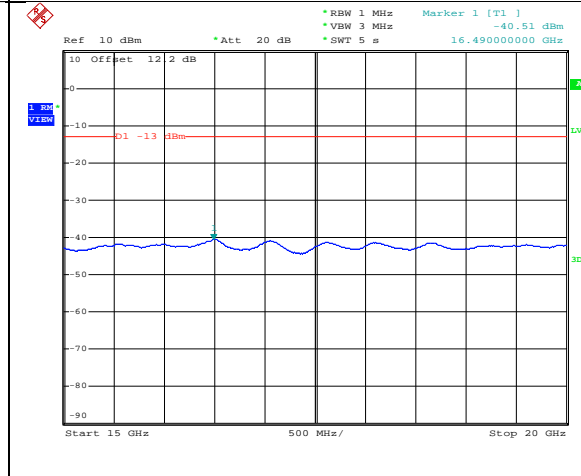
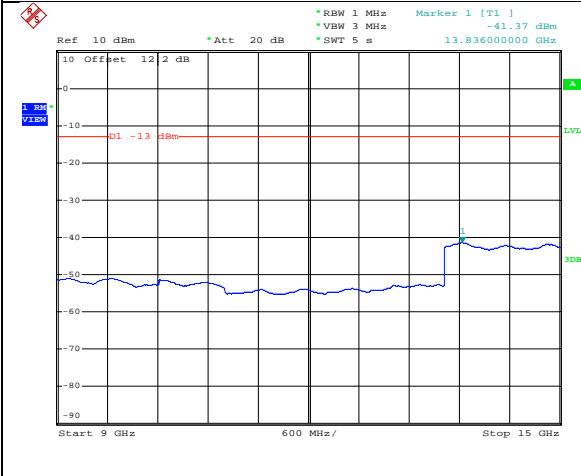

9 GHz~15 GHz

15 GHz~20GHz



LTE FDD Band 2-1.4MHz Channel Bandwidth

High Channel

QPSK

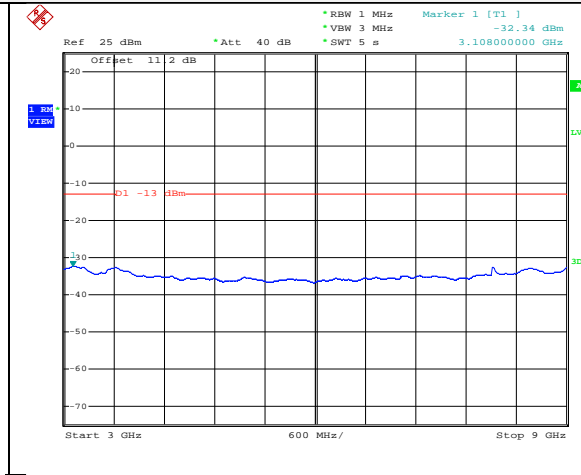
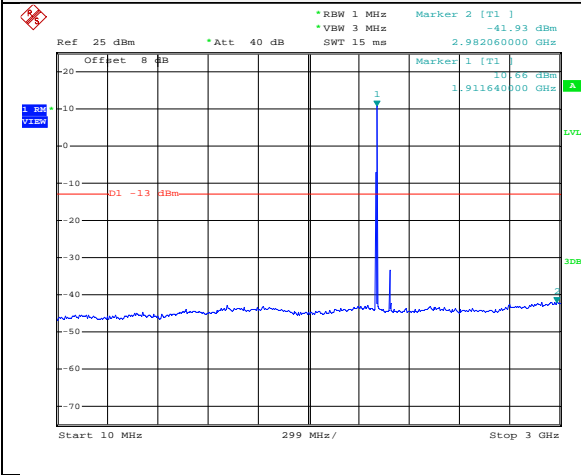

10MHz~3GHz

3GHz~9GHz

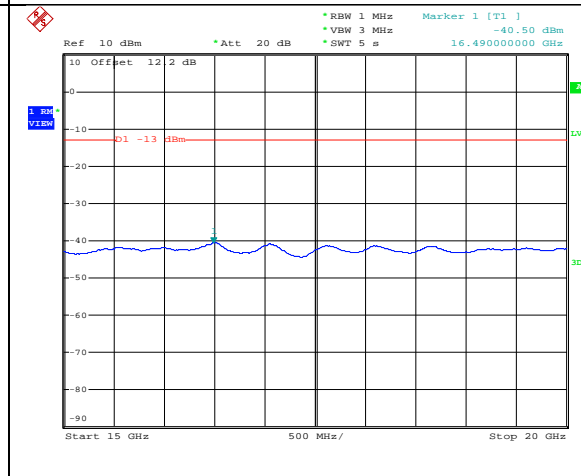
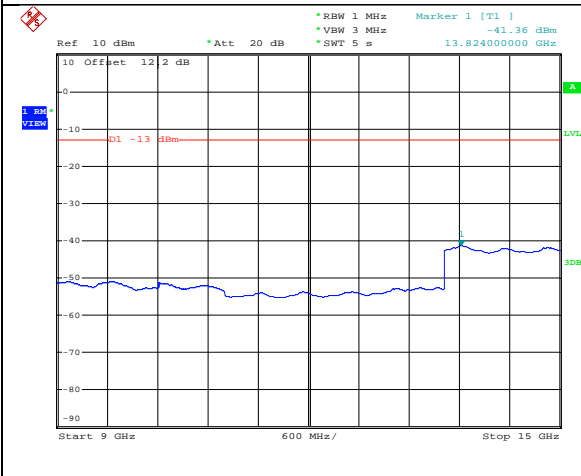

9 GHz ~15 GHz

15 GHz ~20GHz





LTE FDD Band 2-3MHz Channel Bandwidth

Low Channel

QPSK

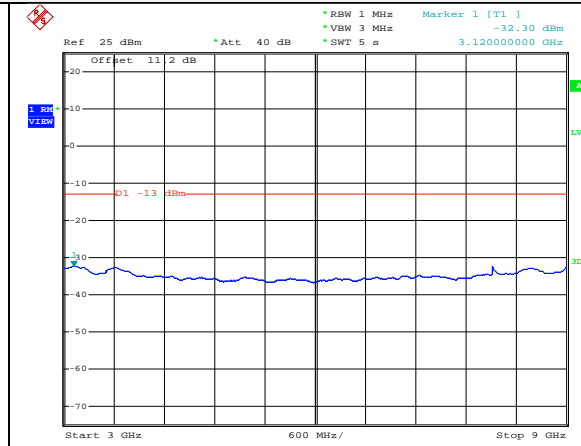
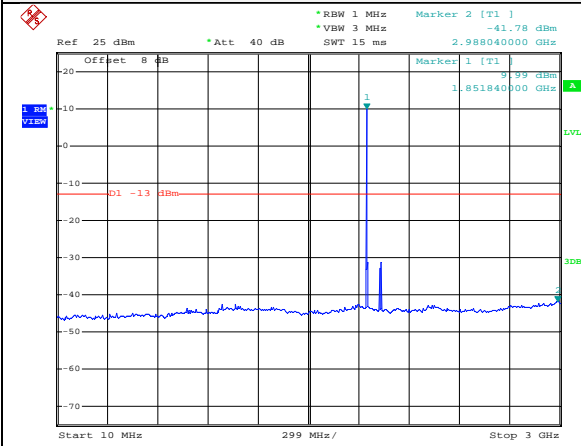

10MHz~3GHz

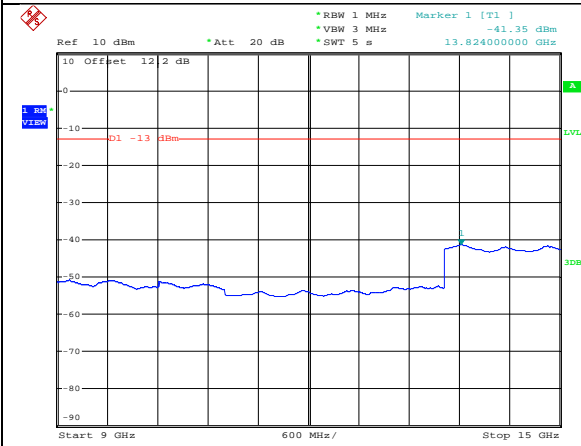

3GHz~9GHz

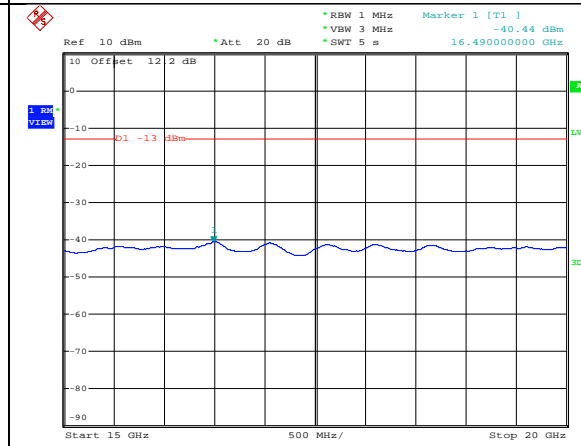

9 GHz ~15 GHz

15 GHz ~20GHz



### LTE FDD Band 2-3MHz Channel Bandwidth

#### Middle Channel

#### QPSK

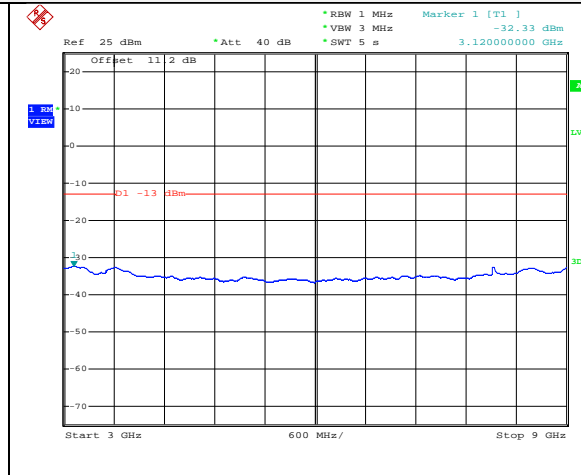
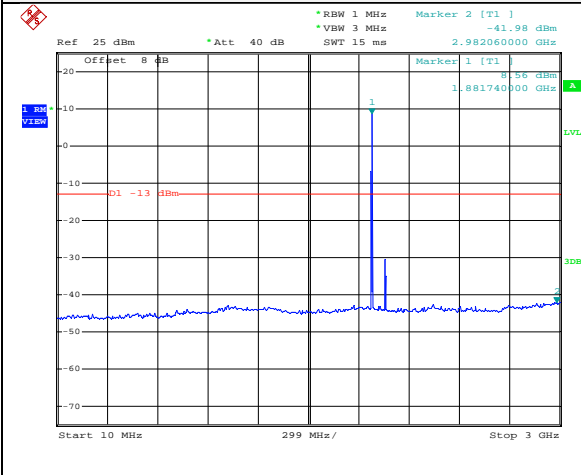

#### 10MHz~3GHz

#### 3GHz~9GHz

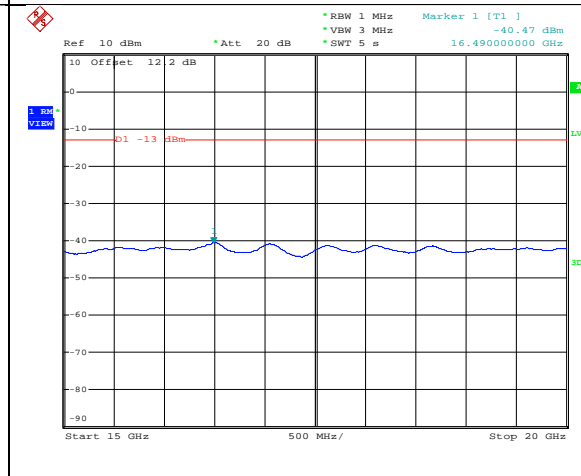
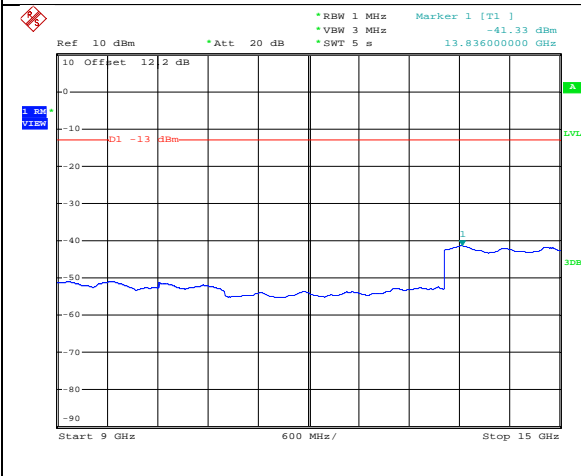

#### 9 GHz~15 GHz

#### 15 GHz~20GHz



LTE FDD Band 2-3MHz Channel Bandwidth

High Channel

QPSK

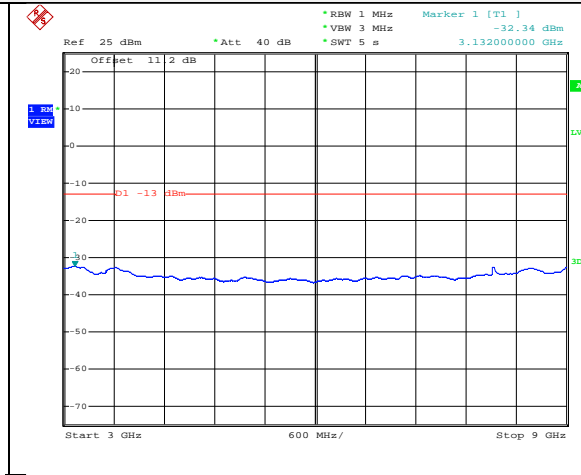
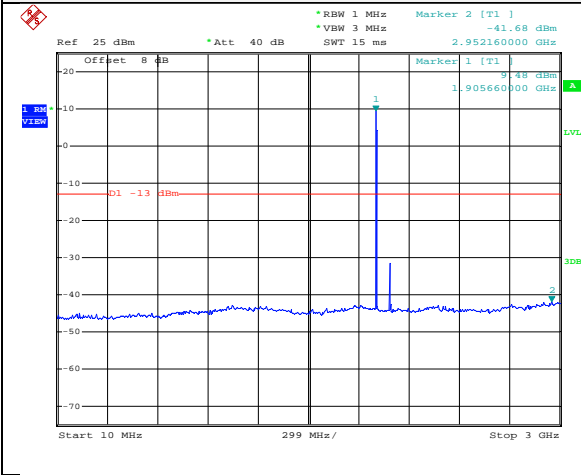

10MHz~3GHz

3GHz~9GHz

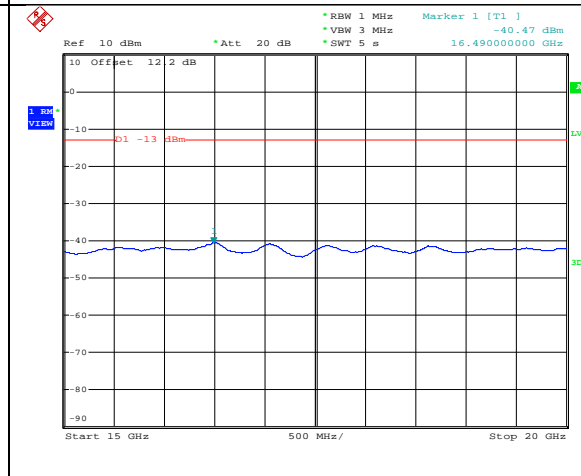
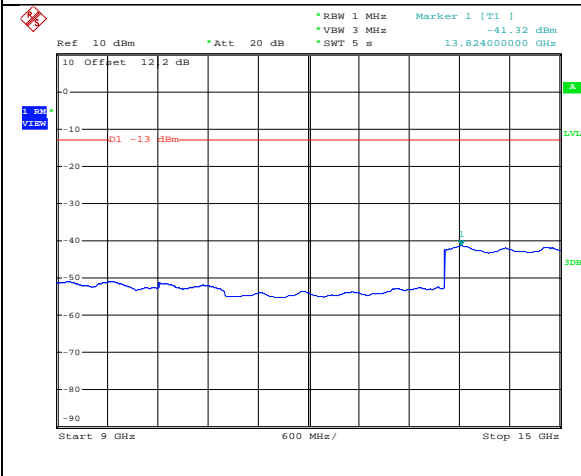

9 GHz~15 GHz

15 GHz~20GHz



### LTE FDD Band 2-5 MHz Channel Bandwidth

#### Low Channel

#### QPSK

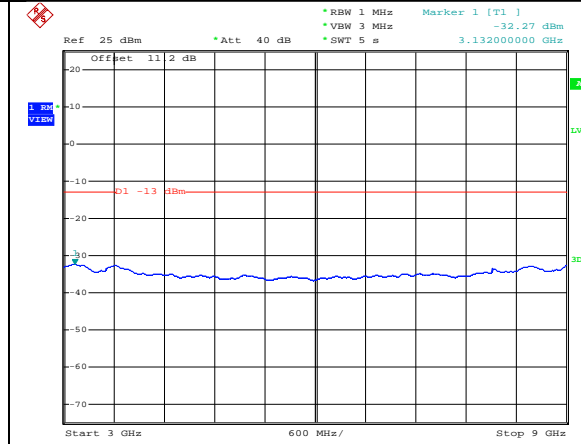
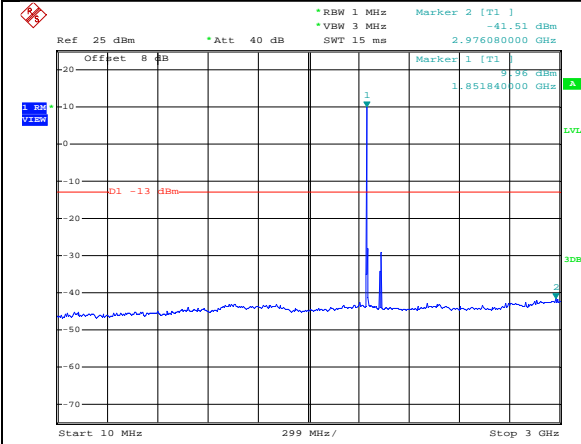

#### 10MHz~3GHz

#### 3GHz~9GHz

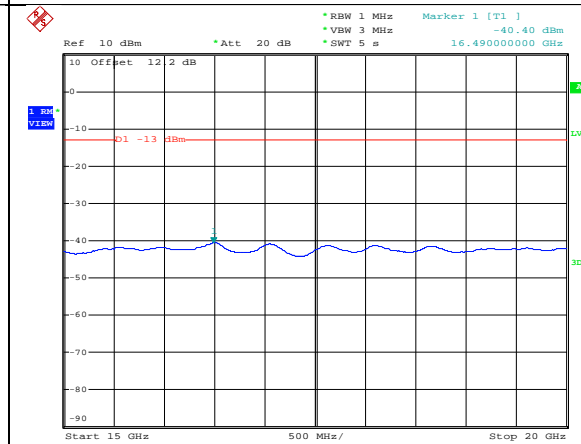
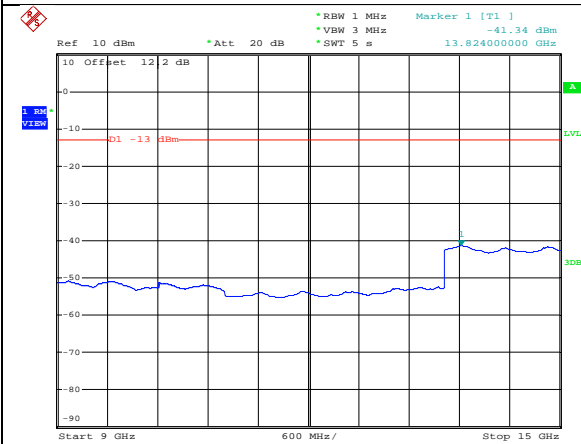

#### 9 GHz ~15 GHz

#### 15 GHz ~20GHz



LTE FDD Band 2-5 MHz Channel Bandwidth

Middle Channel

QPSK

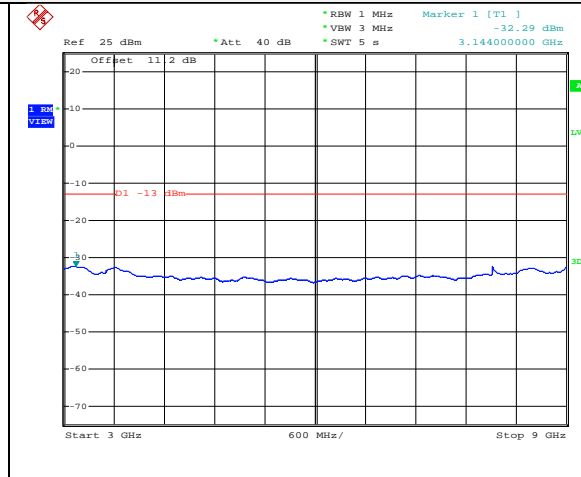
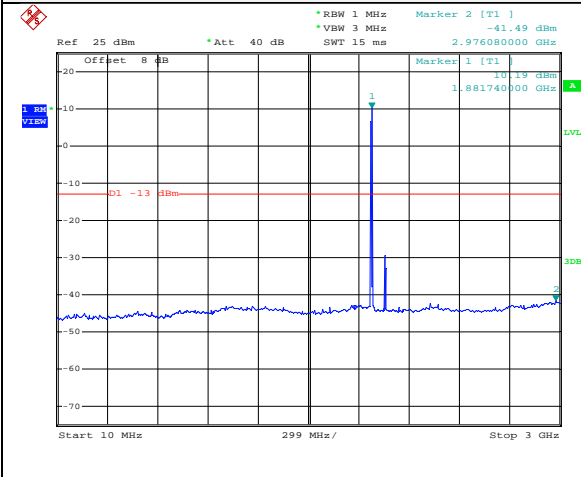

10MHz~3GHz

3GHz~9GHz

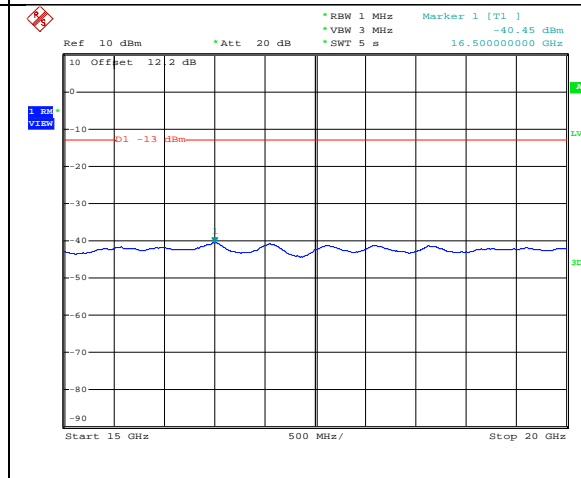
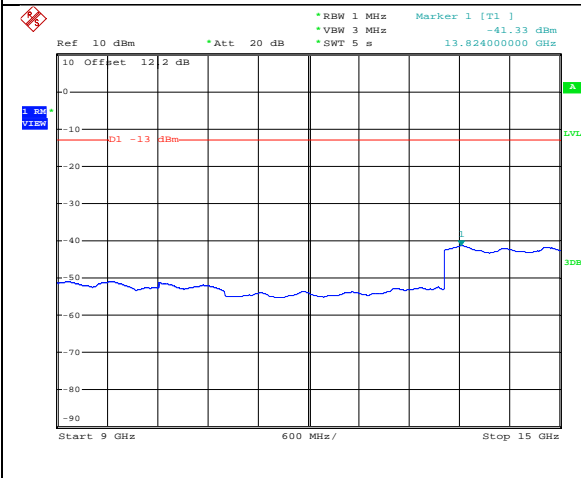

9 GHz~15 GHz

15 GHz~20GHz



LTE FDD Band 2-5 MHz Channel Bandwidth

High Channel

QPSK

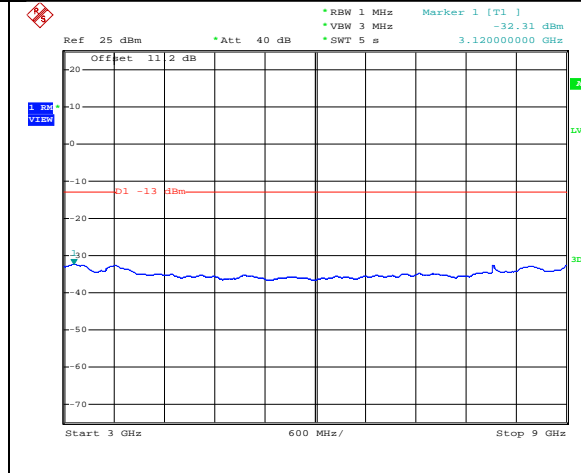
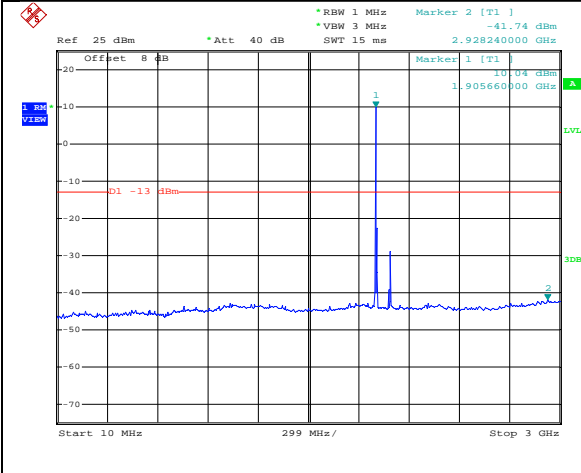

10MHz~3GHz

3GHz~9GHz

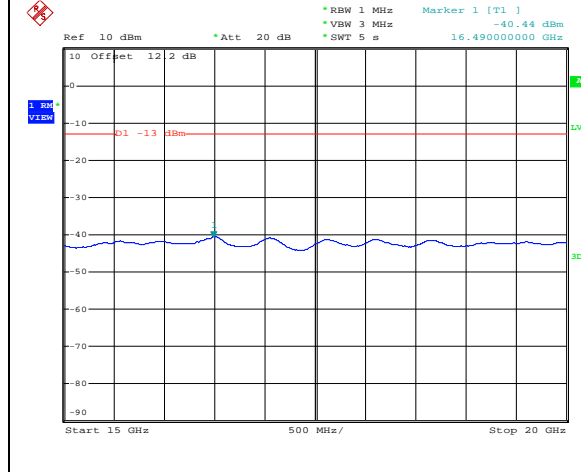
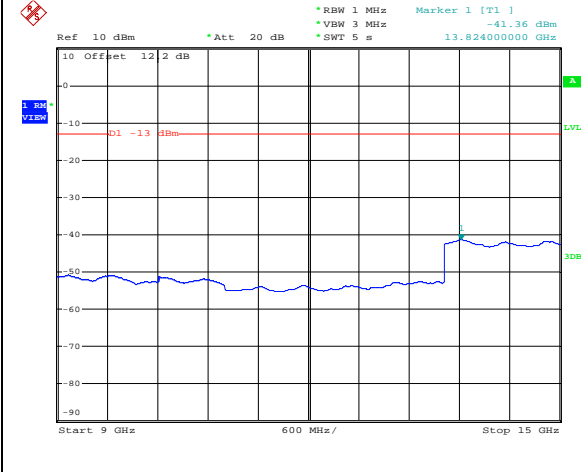

9 GHz ~15 GHz

15 GHz ~20GHz



LTE FDD Band 2-10 MHz Channel Bandwidth

Low Channel

QPSK

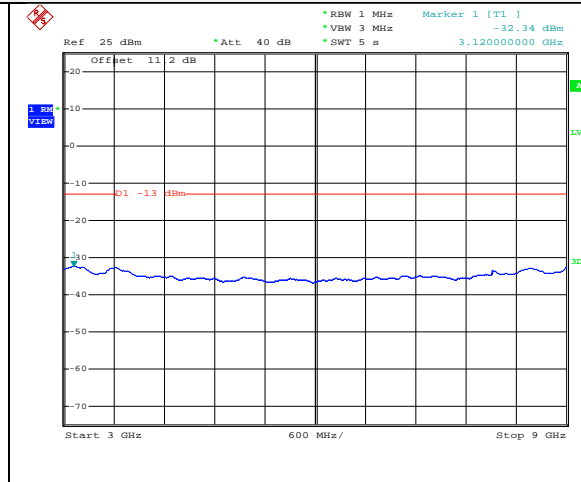
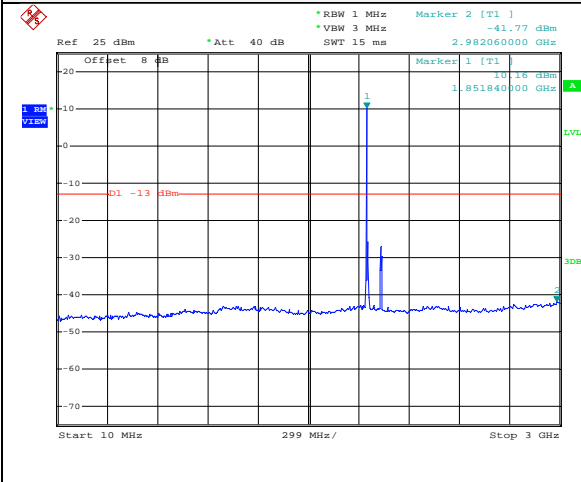

10MHz~3GHz

3GHz~9GHz

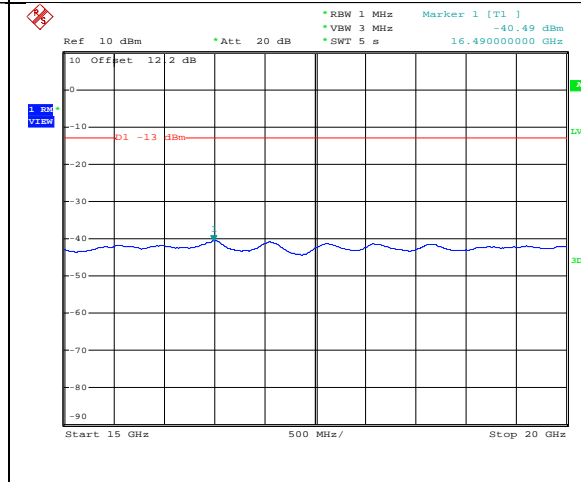
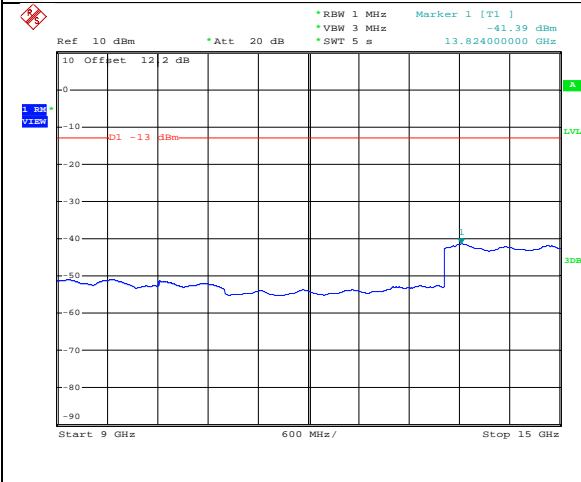

9 GHz ~15 GHz

15 GHz ~20GHz



LTE FDD Band 2-10 MHz Channel Bandwidth

Middle Channel

QPSK

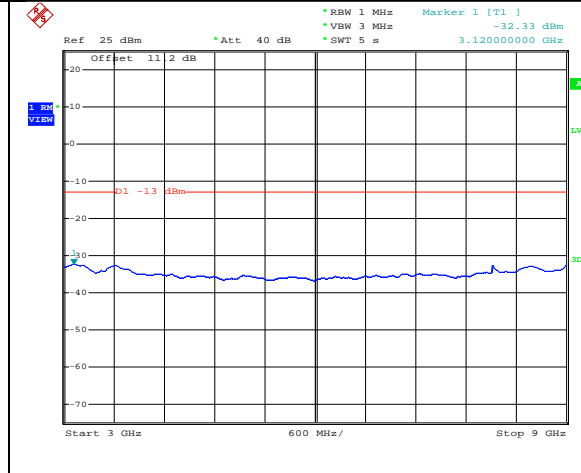
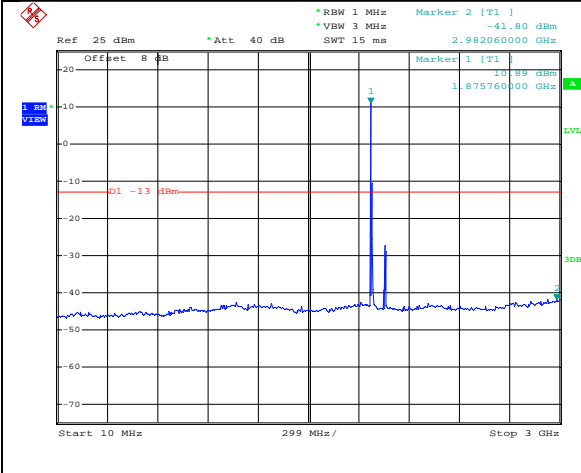

10MHz~3GHz

3GHz~9GHz

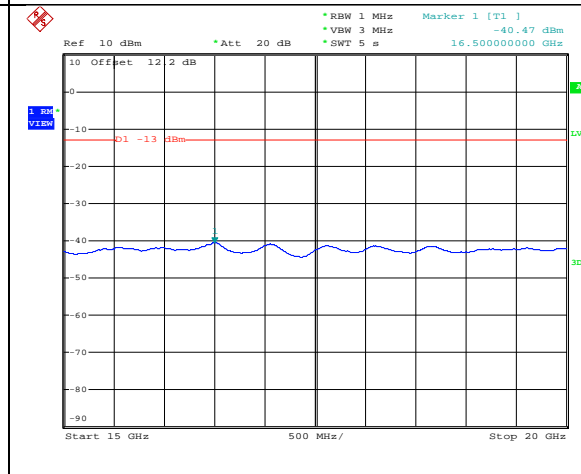
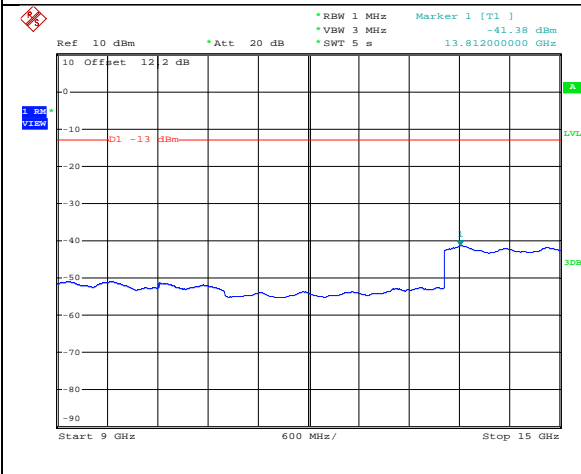

9 GHz~15 GHz

15 GHz~20GHz





LTE FDD Band 2-10 MHz Channel Bandwidth

High Channel

QPSK

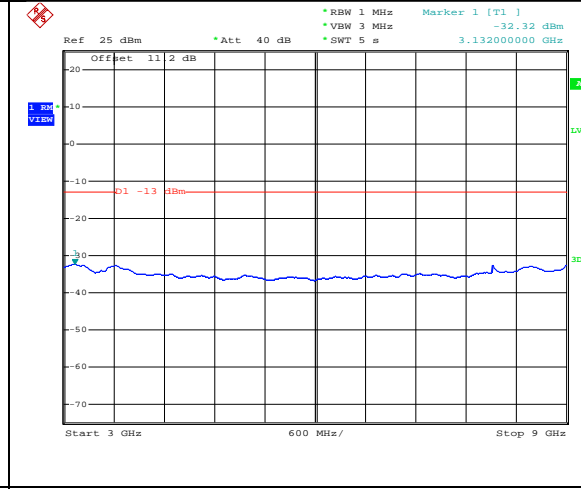
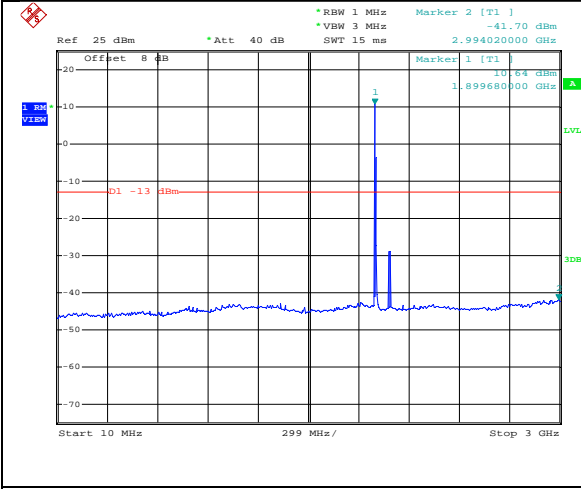

10MHz~3GHz

3GHz~9GHz

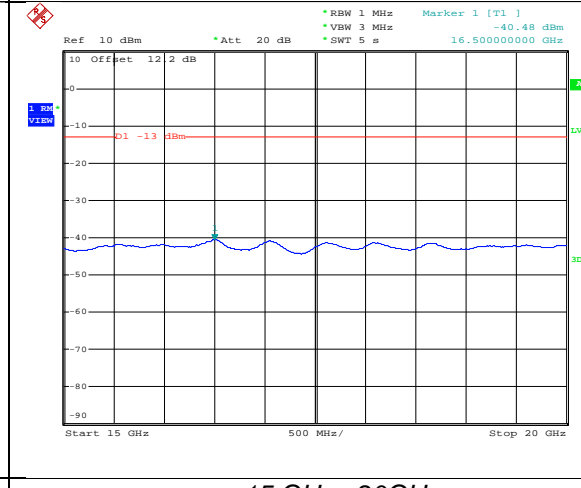
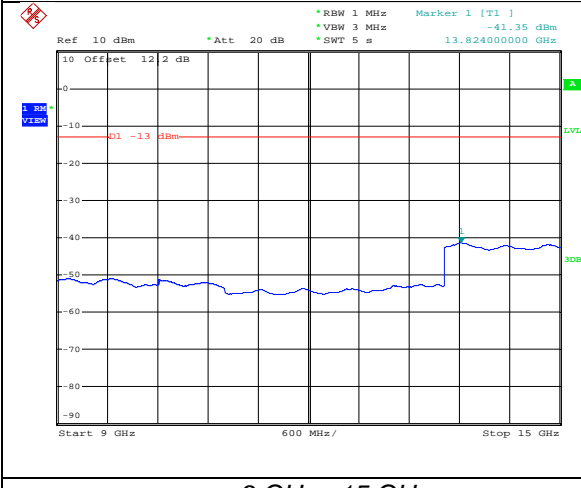

9 GHz ~15 GHz

15 GHz ~20GHz



LTE FDD Band 2-15 MHz Channel Bandwidth

Low Channel

QPSK

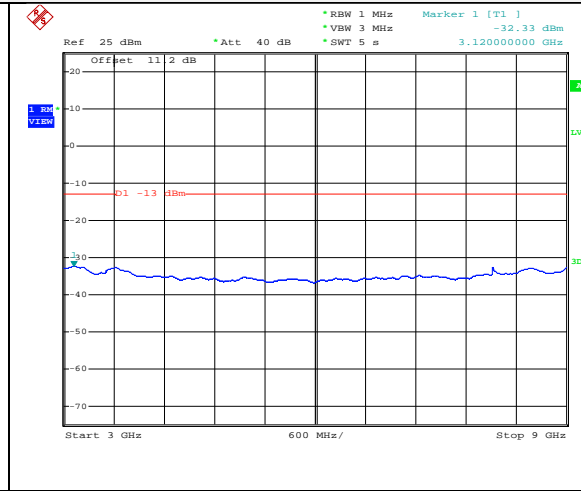
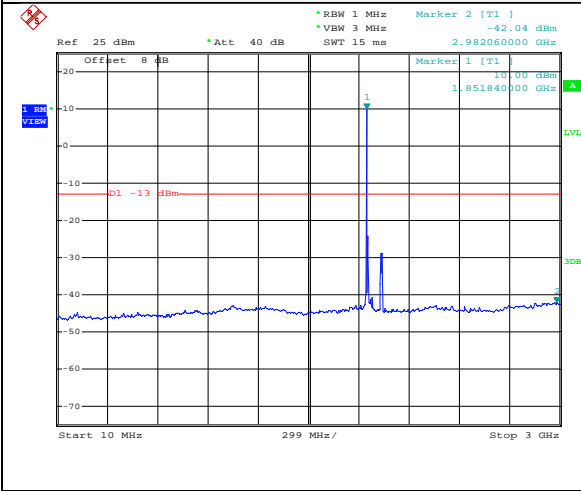

10MHz~3GHz

3GHz~9GHz

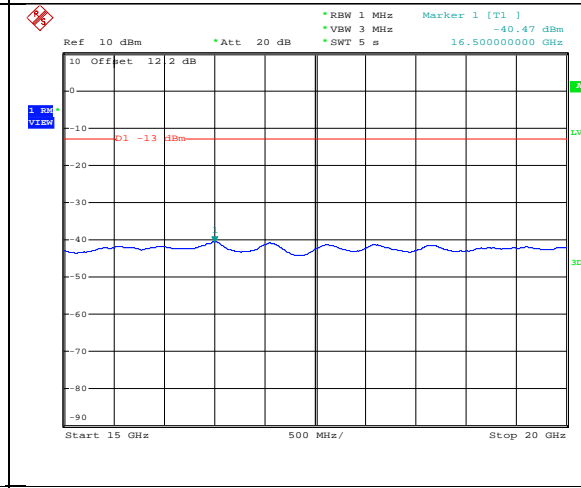
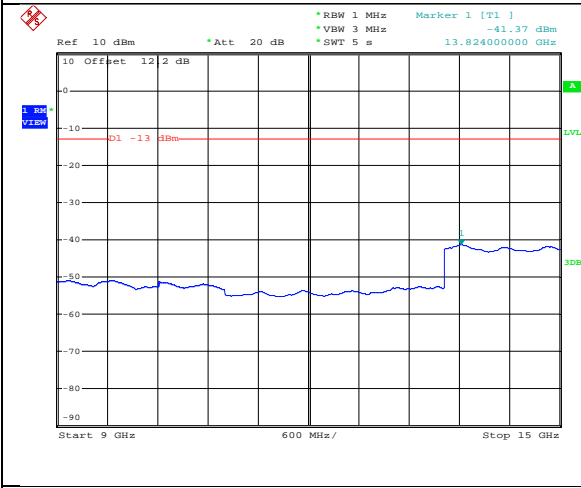

9 GHz~15 GHz

15 GHz~20GHz



LTE FDD Band 2-15 MHz Channel Bandwidth

Middle Channel

QPSK

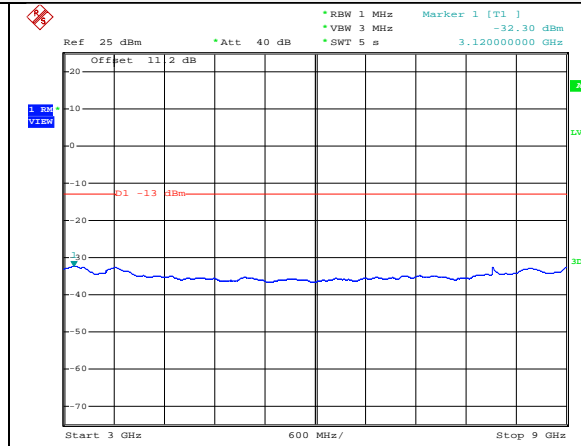
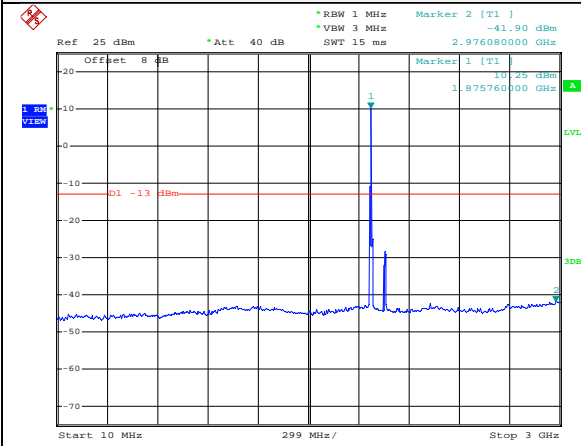

10MHz~3GHz

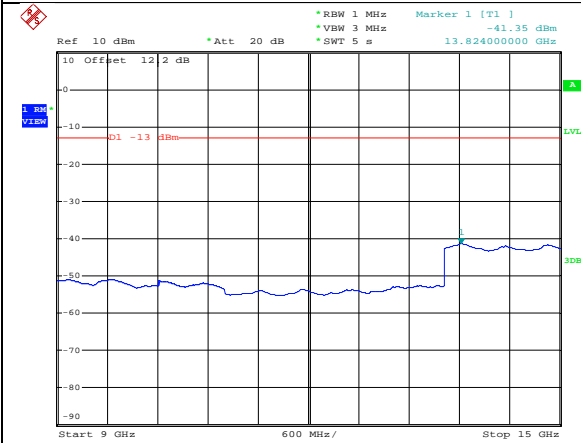

3GHz~9GHz

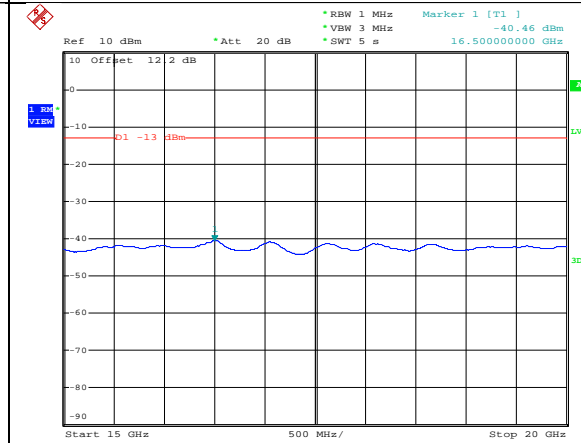

9 GHz ~15 GHz

15 GHz ~20GHz



LTE FDD Band 2-15 MHz Channel Bandwidth

High Channel

QPSK

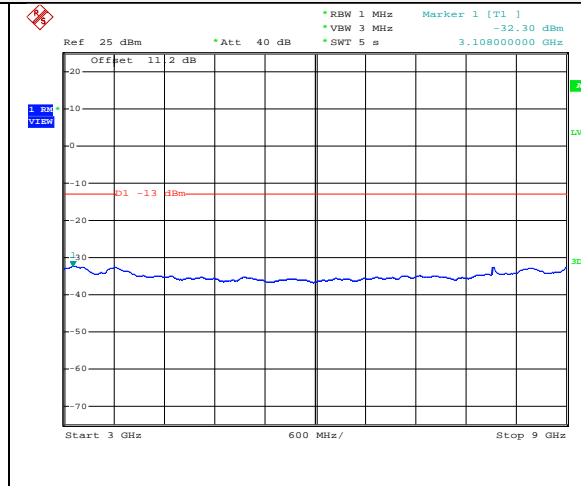
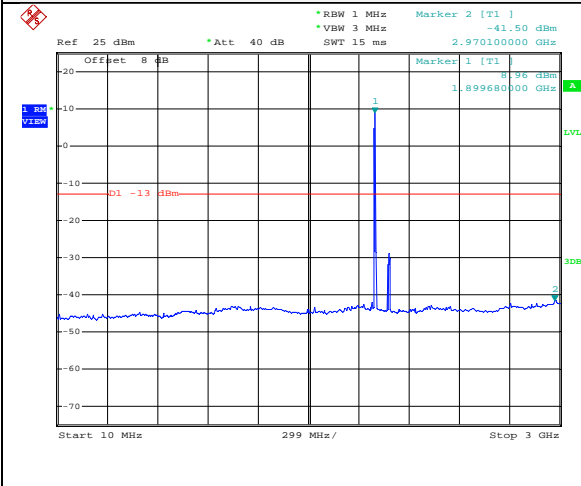

10MHz~3GHz

3GHz~9GHz

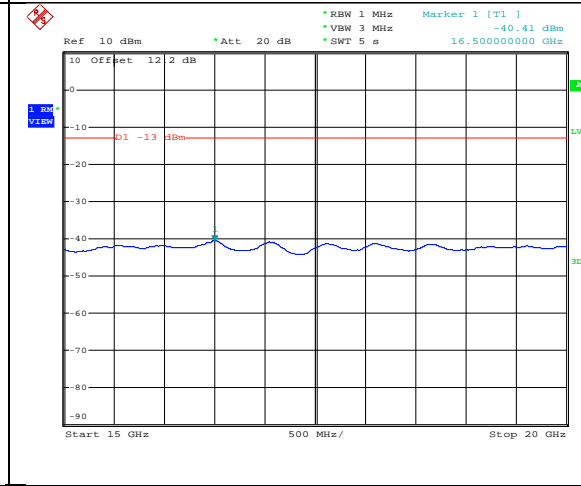
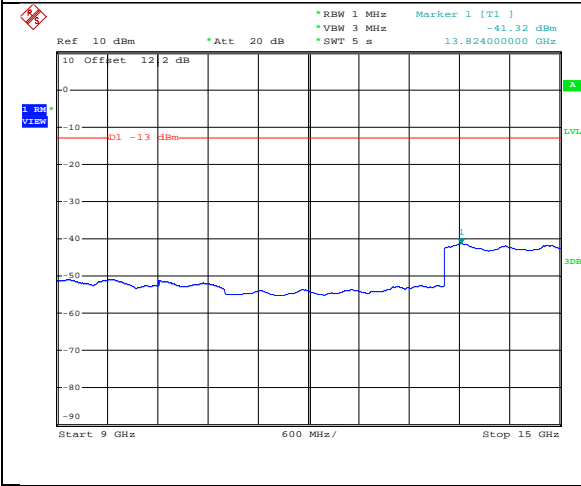

9 GHz ~15 GHz

15 GHz ~20GHz



LTE FDD Band 2-20 MHz Channel Bandwidth

Low Channel

QPSK

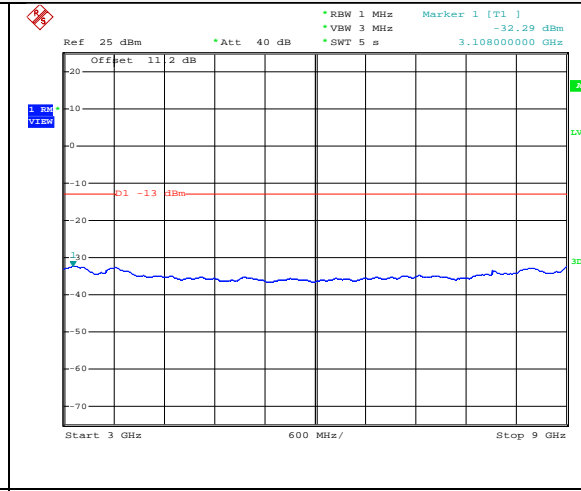
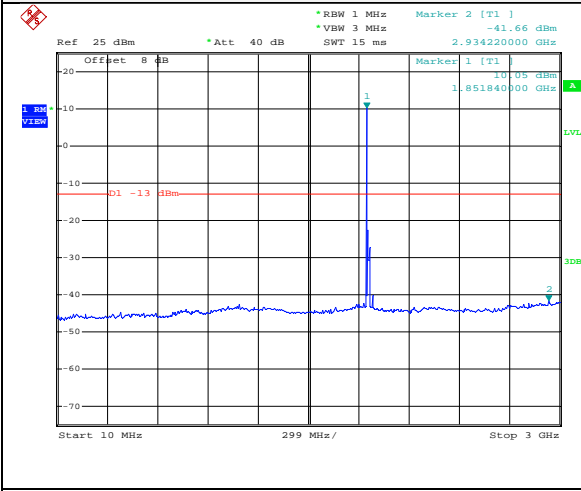

10MHz~3GHz

3GHz~9GHz

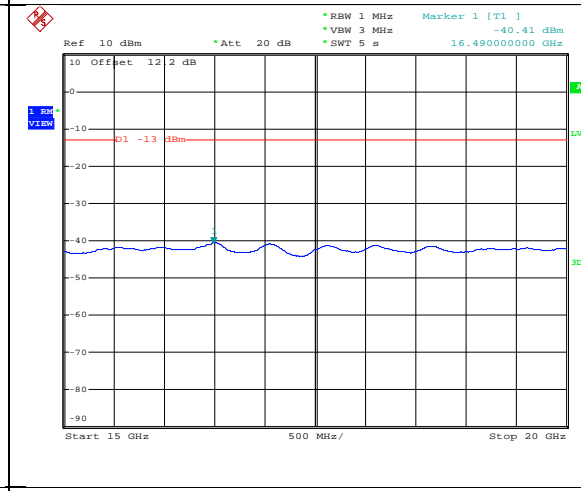
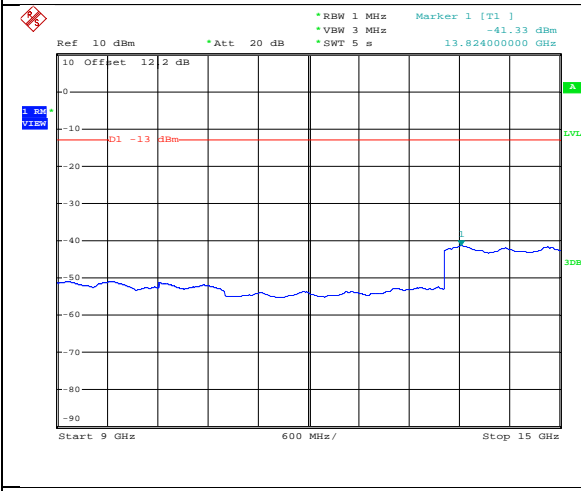

9 GHz ~15 GHz

15 GHz ~20GHz



LTE FDD Band 2-20 MHz Channel Bandwidth

Middle Channel

QPSK

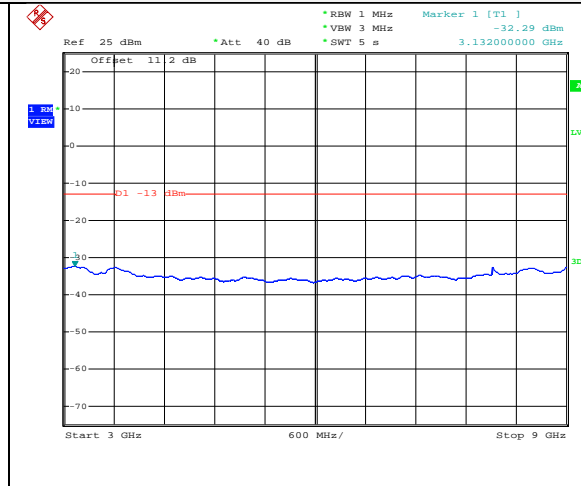
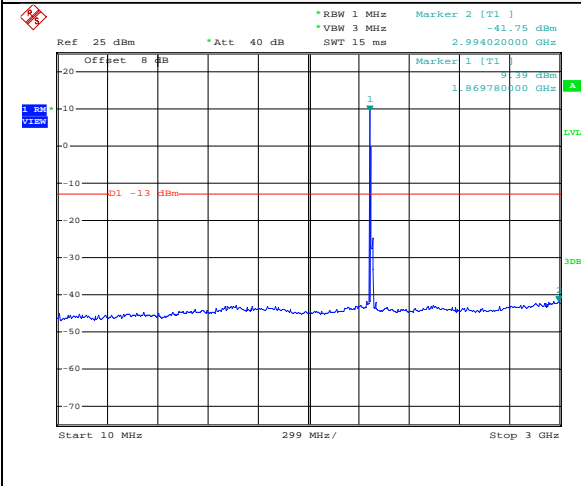

10MHz~3GHz

3GHz~9GHz

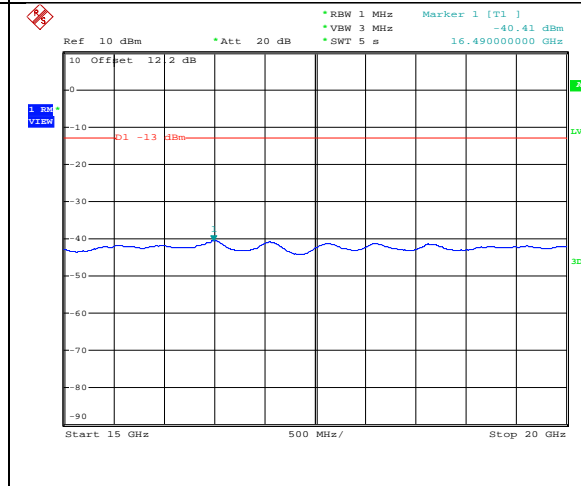
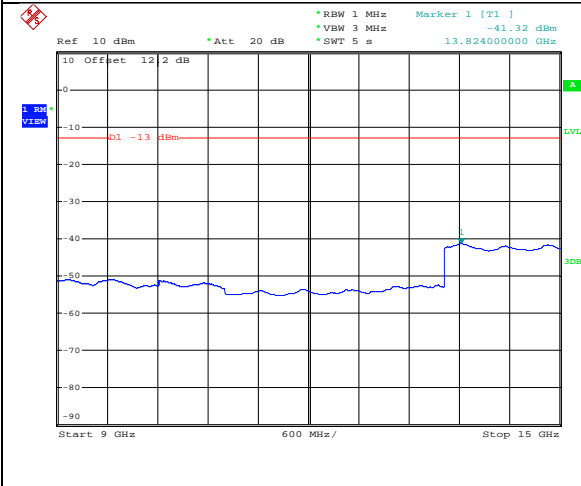

9 GHz~15 GHz

15 GHz~20GHz



LTE FDD Band 2-20 MHz Channel Bandwidth

High Channel

QPSK

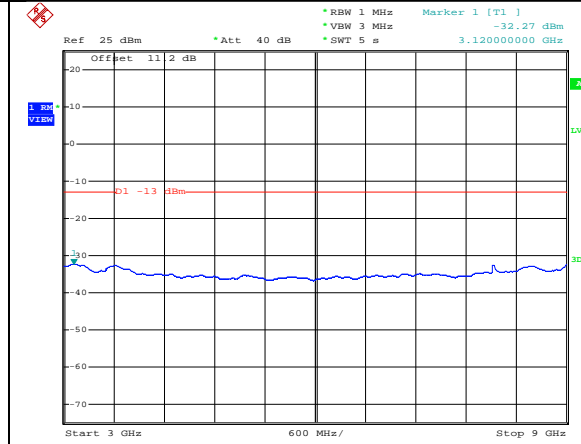
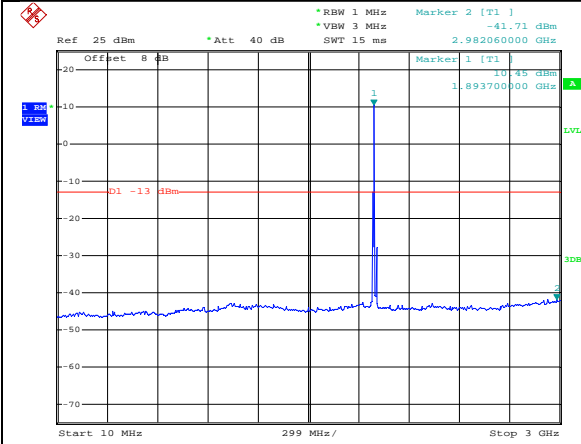

10MHz~3GHz

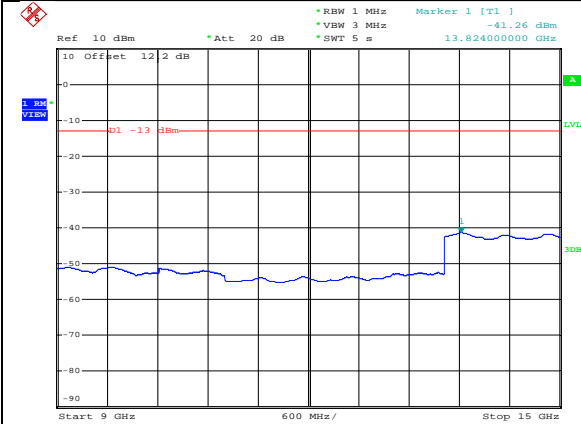

3GHz~9GHz

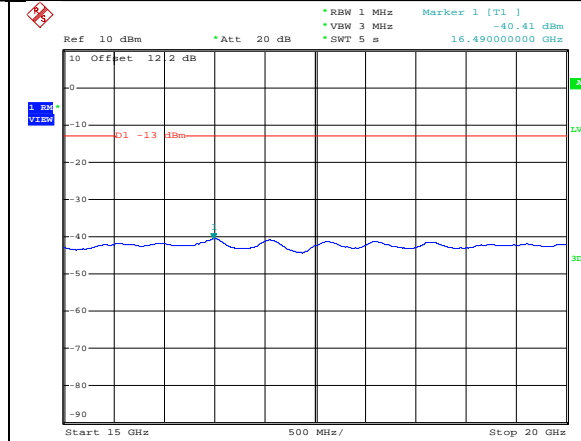

9 GHz ~15 GHz

15 GHz ~20GHz

## 4.6 Radiated Spurious Emission

### TEST APPLICABLE

Per FCC §24.238, the power of any emission outside of the authorized operating frequency ranges must be attenuated below the transmitting power (P) by a factor of at least  $43 + 10\log(P)$  dB.

### TEST CONFIGURATION

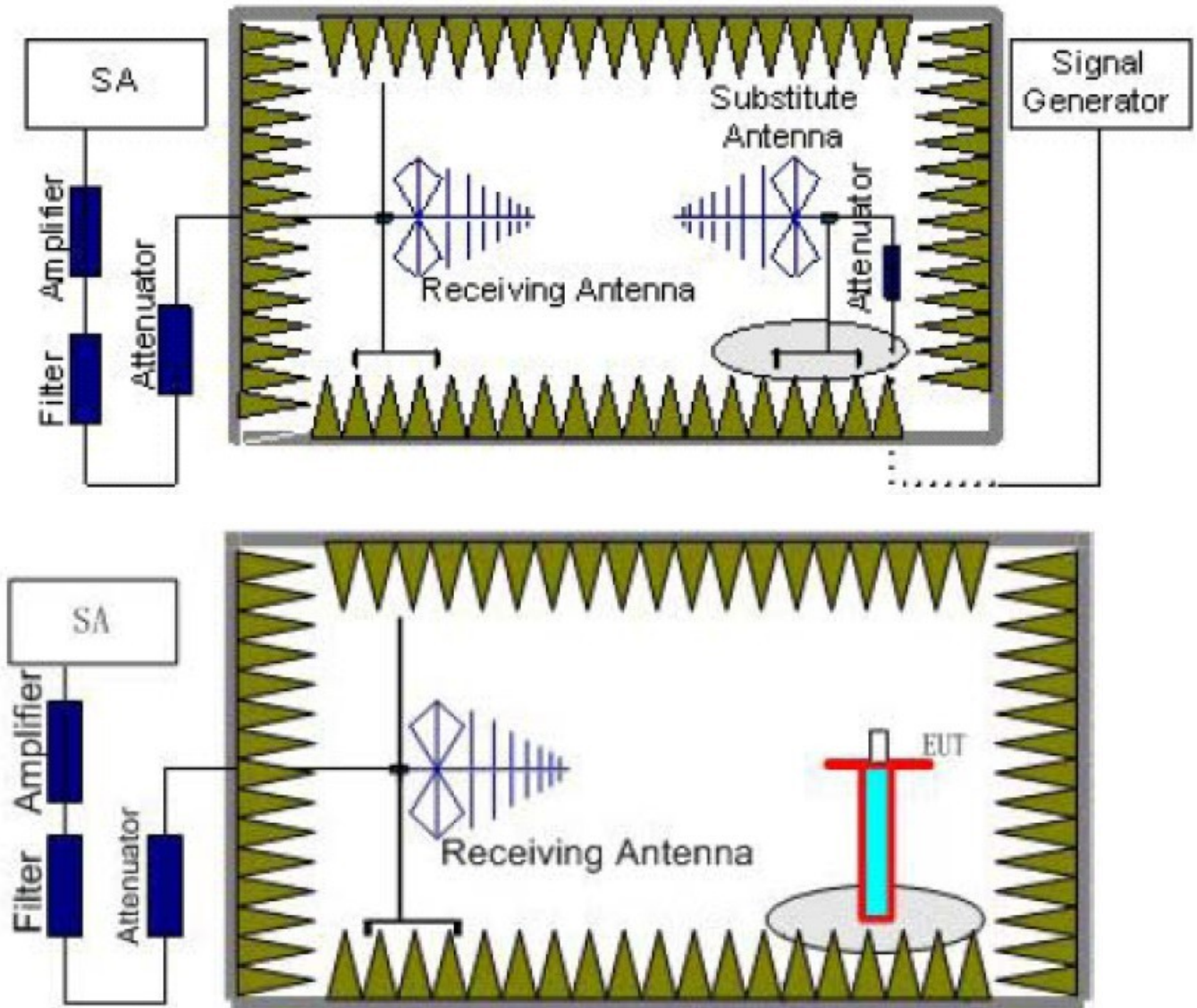

### TEST PROCEDURE

1. EUT was placed on a 1.50 meter high non-conductive stand at a 3 meter test distance from the receive antenna. A receiving antenna was placed on the antenna mast 3 meters from the EUT for emission measurements. The height of receiving antenna is 1.50m. Detected emissions were maximized at each frequency by rotating the EUT through 360° and adjusting the receiving antenna polarization. The radiated emission measurements of all transmit frequencies in three channels (High, Middle, Low) were measured with peak detector.
2. A log-periodic antenna or double-ridged waveguide horn antenna shall be substituted in place of the EUT. The log-periodic antenna will be driven by a signal generator and the level will be adjusted till the same power value on the spectrum analyzer or receiver. The level of the spurious emissions can be calculated through the level of the signal generator, cable loss, the gain of the substitution antenna and the reading of the spectrum analyzer or receiver.





3. The EUT is then put into continuously transmitting mode at its maximum power level during the test. Set Test Receiver or Spectrum RBW=1MHz, VBW=3MHz, And the maximum value of the receiver should be recorded as ( $P_r$ ).
4. The EUT shall be replaced by a substitution antenna. In the chamber, an substitution antenna for the frequency band of interest is placed at the reference point of the chamber. An RF Signal source for the frequency band of interest is disconnected to the substitution antenna with a cable that has been constructed to not interfere with the radiation pattern of the antenna. A power ( $P_{Mea}$ ) is applied to the input of the substitution antenna, and adjust the level of the signal generator output until the value of the receiver reach the previously recorded ( $P_r$ ). The power of signal source ( $P_{Mea}$ ) is recorded. The test should be performed by rotating the test item and adjusting the receiving antenna polarization.
5. A amplifier should be connected to the Signal Source output port. And the cable should be connect between the Amplifier and the Substitution Antenna. The cable loss ( $P_{cl}$ ), the Substitution Antenna Gain ( $G_a$ ) and the Amplifier Gain ( $P_{Ag}$ ) should be recorded after test.  
The measurement results are obtained as described below:  
 $Power(EIRP) = P_{Mea} - P_{Ag} - P_{cl} + G_a$
6. This value is EIRP since the measurement is calibrated using an antenna of known gain (2.15 dBi) and known input power.
7. ERP can be calculated from EIRP by subtracting the gain of the dipole,  $ERP = EIRP - 2.15dBi$ .
8. In order to make sure test results more clearly, we set frequency range and sweep time for difference frequency range as follows table:

Working Frequency	Subrange (GHz)	RBW	VBW	Sweep time (s)
LTE FDD Band 2	0.03~1	100KHz	300KHz	10
	1~20	1 MHz	3 MHz	2

**TEST LIMITS**

According to 24.238 specify that the power of any emission outside of the authorized operating frequency ranges must be attenuated below the transmitting power (P) by a factor of at least  $43 + 10 \log(P)$  dB. The specification that emissions shall be attenuated below the transmitter power (P) by at least  $43 + 10 \log(P)$  dB, translates in the relevant power range (1 to 0.001 W) to -13 dBm. At 1 W the specified minimum attenuation becomes 43 dB and relative to a 30 dBm (1 W) carrier becomes a limit of -13 dBm. At 0.001 W (0 dBm) the minimum attenuation is 13 dB, which again yields a limit of -13 dBm. In this way a translation of the specification from relative to absolute terms is carried out.

Frequency	Channel	Frequency Range	Verdict
LTE FDD Band 2	Low	30MHz -20GHz	PASS
	Middle	30MHz -20GHz	PASS
	High	30MHz -20GHz	PASS

**Radiated Measurement:**

Remark:

1. We measured all RB Configuration refer 3GPP TS136 521 for each Channel Bandwidth of LTE FDD Band 2; recorded worst case for each Channel Bandwidth of LTE FDD Band 2.
2.  $EIRP = P_{Mea}(dBm) - P_{cl}(dB) + G_a(dBi)$
3. Not recorded other points as values lower than limits.
4.  $Margin = Limit - EIRP$

*LTE FDD Band 2\_Channel Bandwidth 1.4MHz\_QPSK\_Low Channel*

Frequency (MHz)	$P_{Mea}$ (dBm)	$P_{cl}$ (dB)	Diatance	$G_a$ Antenna Gain(dB)	Peak EIRP (dBm)	Limit (dBm)	Margin (dB)	Polarization
3701.4	-43.54	4.39	3.00	12.34	-35.59	-13.00	22.59	H
5552.1	-48.88	5.31	3.00	13.52	-40.67	-13.00	27.67	H
3701.4	-50.43	4.39	3.00	12.34	-42.48	-13.00	29.48	V
5552.1	-53.89	5.31	3.00	13.52	-45.68	-13.00	32.68	V

*LTE FDD Band 2\_Channel Bandwidth 1.4MHz\_QPSK\_Middle Channel*

Frequency (MHz)	P <sub>Mea</sub> (dBm)	P <sub>cl</sub> (dB)	Diatance	G <sub>a</sub> Antenna Gain(dB)	Peak EIRP (dBm)	Limit (dBm)	Margin (dB)	Polarization
3760.0	-40.57	4.41	3.00	12.34	-32.64	-13.00	19.64	H
5640.0	-47.73	5.38	3.00	13.58	-39.53	-13.00	26.53	H
3760.0	-42.85	4.41	3.00	12.34	-34.92	-13.00	21.92	V
5640.0	-45.22	5.38	3.00	13.58	-37.02	-13.00	24.02	V

*LTE FDD Band 2\_Channel Bandwidth 1.4MHz\_QPSK\_High Channel*

Frequency (MHz)	P <sub>Mea</sub> (dBm)	P <sub>cl</sub> (dB)	Diatance	G <sub>a</sub> Antenna Gain(dB)	Peak EIRP (dBm)	Limit (dBm)	Margin (dB)	Polarization
3806.6	-43.97	4.45	3.00	12.45	-35.97	-13.00	22.97	H
5709.9	-47.82	5.47	3.00	13.66	-39.63	-13.00	26.63	H
3806.6	-46.23	4.45	3.00	12.45	-38.23	-13.00	25.23	V
5709.9	-49.11	5.48	3.00	13.66	-40.93	-13.00	27.93	V

*LTE FDD Band 2\_Channel Bandwidth 3MHz\_QPSK\_Low Channel*

Frequency (MHz)	P <sub>Mea</sub> (dBm)	P <sub>cl</sub> (dB)	Diatance	G <sub>a</sub> Antenna Gain(dB)	Peak EIRP (dBm)	Limit (dBm)	Margin (dB)	Polarization
3703.0	-43.89	4.39	3.00	12.34	-35.94	-13.00	22.94	H
5554.5	-48.83	5.31	3.00	13.52	-40.62	-13.00	27.62	H
3703.0	-41.16	4.39	3.00	12.34	-33.21	-13.00	20.21	V
5554.5	-51.34	5.31	3.00	13.52	-43.13	-13.00	30.13	V

*LTE FDD Band 2\_Channel Bandwidth 3MHz\_QPSK\_Middle Channel*

Frequency (MHz)	P <sub>Mea</sub> (dBm)	P <sub>cl</sub> (dB)	Diatance	G <sub>a</sub> Antenna Gain(dB)	Peak EIRP (dBm)	Limit (dBm)	Margin (dB)	Polarization
3760.0	-42.87	4.41	3.00	12.34	-34.94	-13.00	21.94	H
5640.0	-49.91	5.38	3.00	13.58	-41.71	-13.00	28.71	H
3760.0	-42.17	4.41	3.00	12.34	-34.24	-13.00	21.24	V
5640.0	-50.91	5.38	3.00	13.58	-42.71	-13.00	29.71	V

*LTE FDD Band 2\_Channel Bandwidth 3MHz\_QPSK\_High Channel*

Frequency (MHz)	P <sub>Mea</sub> (dBm)	P <sub>cl</sub> (dB)	Diatance	G <sub>a</sub> Antenna Gain(dB)	Peak EIRP (dBm)	Limit (dBm)	Margin (dB)	Polarization
3817.0	-44.13	4.45	3.00	12.45	-36.13	-13.00	23.13	H
5725.5	-47.74	5.47	3.00	13.66	-39.55	-13.00	26.55	H
3817.0	-45.27	4.45	3.00	12.45	-37.27	-13.00	24.27	V
5725.5	-51.11	5.48	3.00	13.66	-42.93	-13.00	29.93	V

*LTE FDD Band 2\_Channel Bandwidth 5MHz\_QPSK\_Low Channel*

Frequency (MHz)	P <sub>Mea</sub> (dBm)	P <sub>cl</sub> (dB)	Diatance	G <sub>a</sub> Antenna Gain(dB)	Peak EIRP (dBm)	Limit (dBm)	Margin (dB)	Polarization
3705.0	-45.06	4.39	3.00	12.34	-37.11	-13.00	24.11	H
5557.5	-49.90	5.31	3.00	13.52	-41.69	-13.00	28.69	H
3705.0	-43.77	4.39	3.00	12.34	-35.82	-13.00	22.82	V
5557.5	-51.22	5.31	3.00	13.52	-43.01	-13.00	30.01	V

*LTE FDD Band 2\_Channel Bandwidth 5MHz\_QPSK\_Middle Channel*

Frequency (MHz)	P <sub>Mea</sub> (dBm)	P <sub>cl</sub> (dB)	Diatance	G <sub>a</sub> Antenna Gain(dB)	Peak EIRP (dBm)	Limit (dBm)	Margin (dB)	Polarization
3760.0	-43.66	4.41	3.00	12.34	-35.73	-13.00	22.73	H
5640.0	-51.01	5.38	3.00	13.58	-42.81	-13.00	29.81	H
3760.0	-43.18	4.41	3.00	12.34	-35.25	-13.00	22.25	V
5640.0	-53.21	5.38	3.00	13.58	-45.01	-13.00	32.01	V

*LTE FDD Band 2\_Channel Bandwidth 5MHz\_QPSK\_High Channel*

Frequency (MHz)	P <sub>Mea</sub> (dBm)	P <sub>cl</sub> (dB)	Diatance	G <sub>a</sub> Antenna Gain(dB)	Peak EIRP (dBm)	Limit (dBm)	Margin (dB)	Polarization
3815.0	-44.34	4.45	3.00	12.45	-36.34	-13.00	23.34	H
5722.5	-48.92	5.47	3.00	13.66	-40.73	-13.00	27.73	H
3815.0	-43.33	4.45	3.00	12.45	-35.33	-13.00	22.33	V
5722.5	-51.24	5.48	3.00	13.66	-43.06	-13.00	30.06	V

*LTE FDD Band 2\_Channel Bandwidth 10MHz\_QPSK\_Low Channel*

Frequency (MHz)	P <sub>Mea</sub> (dBm)	P <sub>cl</sub> (dB)	Diatance	G <sub>a</sub> Antenna Gain(dB)	Peak EIRP (dBm)	Limit (dBm)	Margin (dB)	Polarization
3710.0	-41.17	4.39	3.00	12.34	-33.22	-13.00	20.22	H
5565.0	-49.94	5.31	3.00	13.52	-41.73	-13.00	28.73	H
3710.0	-43.91	4.39	3.00	12.34	-35.96	-13.00	22.96	V
5565.0	-52.57	5.31	3.00	13.52	-44.36	-13.00	31.36	V

*LTE FDD Band 2\_Channel Bandwidth 10MHz\_QPSK\_Middle Channel*

Frequency (MHz)	P <sub>Mea</sub> (dBm)	P <sub>cl</sub> (dB)	Diatance	G <sub>a</sub> Antenna Gain(dB)	Peak EIRP (dBm)	Limit (dBm)	Margin (dB)	Polarization
3760.0	-40.78	4.41	3.00	12.34	-32.85	-13.00	19.85	H
5640.0	-49.18	5.38	3.00	13.58	-40.98	-13.00	27.98	H
3760.0	-43.30	4.41	3.00	12.34	-35.37	-13.00	22.37	V
5640.0	-50.14	5.38	3.00	13.58	-41.94	-13.00	19.85	V

*LTE FDD Band 2\_Channel Bandwidth 10MHz\_QPSK\_High Channel*

Frequency (MHz)	P <sub>Mea</sub> (dBm)	P <sub>cl</sub> (dB)	Diatance	G <sub>a</sub> Antenna Gain(dB)	Peak EIRP (dBm)	Limit (dBm)	Margin (dB)	Polarization
3810.0	-44.87	4.45	3.00	12.45	-36.87	-13.00	23.87	H
5715.0	-50.61	5.47	3.00	13.66	-42.42	-13.00	29.42	H
3810.0	-43.18	4.45	3.00	12.45	-35.18	-13.00	22.18	V
5715.0	-52.58	5.48	3.00	13.66	-44.40	-13.00	31.40	V

*LTE FDD Band 2\_Channel Bandwidth 15MHz\_QPSK\_Low Channel*

Frequency (MHz)	P <sub>Mea</sub> (dBm)	P <sub>cl</sub> (dB)	Diatance	G <sub>a</sub> Antenna Gain(dB)	Peak EIRP (dBm)	Limit (dBm)	Margin (dB)	Polarization
3715.0	-42.79	4.39	3.00	12.34	-34.84	-13.00	21.84	H
5572.5	-49.72	5.31	3.00	13.52	-41.51	-13.00	28.51	H
3715.0	-45.19	4.39	3.00	12.34	-37.24	-13.00	24.24	V
5572.5	-51.39	5.31	3.00	13.52	-43.18	-13.00	30.18	V

*LTE FDD Band 2\_Channel Bandwidth 15MHz\_QPSK\_Middle Channel*

Frequency (MHz)	P <sub>Mea</sub> (dBm)	P <sub>cl</sub> (dB)	Diatance	G <sub>a</sub> Antenna Gain(dB)	Peak EIRP (dBm)	Limit (dBm)	Margin (dB)	Polarization
3760.0	-41.08	4.41	3.00	12.34	-33.15	-13.00	20.15	H
5640.0	-51.02	5.38	3.00	13.58	-42.82	-13.00	29.82	H
3760.0	-37.85	4.41	3.00	12.34	-29.92	-13.00	16.92	V
5640.0	-54.42	5.38	3.00	13.58	-46.22	-13.00	33.22	V

*LTE FDD Band 2\_Channel Bandwidth 15MHz\_QPSK\_High Channel*

Frequency (MHz)	P <sub>Mea</sub> (dBm)	P <sub>cl</sub> (dB)	Diatance	G <sub>a</sub> Antenna Gain(dB)	Peak EIRP (dBm)	Limit (dBm)	Margin (dB)	Polarization
3805.0	-43.02	4.45	3.00	12.45	-35.02	-13.00	22.02	H
5707.5	-49.48	5.47	3.00	13.66	-41.29	-13.00	28.29	H
3805.0	-41.23	4.45	3.00	12.45	-33.23	-13.00	20.23	V
5707.5	-53.09	5.48	3.00	13.66	-44.91	-13.00	31.91	V

*LTE FDD Band 2\_Channel Bandwidth 20MHz\_QPSK\_Low Channel*

Frequency (MHz)	P <sub>Mea</sub> (dBm)	P <sub>cl</sub> (dB)	Diatance	G <sub>a</sub> Antenna Gain(dB)	Peak EIRP (dBm)	Limit (dBm)	Margin (dB)	Polarization
3715.0	-40.97	4.39	3.00	12.34	-33.02	-13.00	20.02	H
5572.5	-49.55	5.31	3.00	13.52	-41.34	-13.00	28.34	H
3715.0	-43.33	4.39	3.00	12.34	-35.38	-13.00	22.38	V
5572.5	-52.66	5.31	3.00	13.52	-44.45	-13.00	31.45	V

*LTE FDD Band 2\_Channel Bandwidth 20MHz\_QPSK\_Middle Channel*

Frequency (MHz)	P <sub>Mea</sub> (dBm)	P <sub>cl</sub> (dB)	Diatance	G <sub>a</sub> Antenna Gain(dB)	Peak EIRP (dBm)	Limit (dBm)	Margin (dB)	Polarization
3720.0	-42.63	4.41	3.00	12.34	-34.70	-13.00	21.70	H
5580.0	-48.81	5.38	3.00	13.58	-40.61	-13.00	27.61	H
3720.0	-43.91	4.41	3.00	12.34	-35.98	-13.00	22.98	V
5580.0	-50.59	5.38	3.00	13.58	-42.39	-13.00	29.39	V

*LTE FDD Band 2\_Channel Bandwidth 20MHz\_QPSK\_High Channel*

Frequency (MHz)	P <sub>Mea</sub> (dBm)	P <sub>cl</sub> (dB)	Diatance	G <sub>a</sub> Antenna Gain(dB)	Peak EIRP (dBm)	Limit (dBm)	Margin (dB)	Polarization
3800.0	-46.75	4.45	3.00	12.45	-35.84	-13.00	22.84	H
5700.0	-50.35	5.47	3.00	13.66	-40.96	-13.00	27.96	H
3800.0	-50.61	4.45	3.00	12.45	-31.96	-13.00	18.96	V
5700.0	-57.22	5.48	3.00	13.66	-45.28	-13.00	32.28	V

*LTE FDD Band 2\_Channel Bandwidth 1.4MHz\_16QAM\_Low Channel*

Frequency (MHz)	P <sub>Mea</sub> (dBm)	P <sub>cl</sub> (dB)	Diatance	G <sub>a</sub> Antenna Gain(dB)	Peak EIRP (dBm)	Limit (dBm)	Margin (dB)	Polarization
3701.4	-39.87	4.39	3.00	12.34	-31.92	-13.00	18.92	H
5552.1	-53.62	5.31	3.00	13.52	-45.41	-13.00	32.41	H
3701.4	-37.82	4.39	3.00	12.34	-29.87	-13.00	16.87	V
5552.1	-50.47	5.31	3.00	13.52	-42.26	-13.00	29.26	V

*LTE FDD Band 2\_Channel Bandwidth 1.4MHz\_16QAM\_Middle Channel*

Frequency (MHz)	P <sub>Mea</sub> (dBm)	P <sub>cl</sub> (dB)	Diatance	G <sub>a</sub> Antenna Gain(dB)	Peak EIRP (dBm)	Limit (dBm)	Margin (dB)	Polarization
3760.0	-40.15	4.41	3.00	12.34	-32.22	-13.00	19.22	H
5640.0	-46.97	5.38	3.00	13.58	-38.77	-13.00	25.77	H
3760.0	-49.68	4.41	3.00	12.34	-41.75	-13.00	28.75	V
5640.0	-51.7	5.38	3.00	13.58	-43.50	-13.00	30.50	V

*LTE FDD Band 2\_Channel Bandwidth 1.4MHz\_16QAM\_High Channel*

Frequency (MHz)	P <sub>Mea</sub> (dBm)	P <sub>cl</sub> (dB)	Diatance	G <sub>a</sub> Antenna Gain(dB)	Peak EIRP (dBm)	Limit (dBm)	Margin (dB)	Polarization
3806.6	-45.42	4.45	3.00	12.45	-37.42	-13.00	24.42	H
5709.9	-49.14	5.47	3.00	13.66	-40.95	-13.00	27.95	H
3806.6	-49.93	4.45	3.00	12.45	-41.93	-13.00	28.93	V
5709.9	-55.75	5.48	3.00	13.66	-47.57	-13.00	34.57	V

*LTE FDD Band 2\_Channel Bandwidth 3MHz\_16QAM\_Low Channel*

Frequency (MHz)	P <sub>Mea</sub> (dBm)	P <sub>cl</sub> (dB)	Diatance	G <sub>a</sub> Antenna Gain(dB)	Peak EIRP (dBm)	Limit (dBm)	Margin (dB)	Polarization
3703.0	-46.19	4.39	3.00	12.34	-38.24	-13.00	25.24	H
5554.5	-47.90	5.31	3.00	13.52	-39.69	-13.00	26.69	H
3703.0	-51.32	4.39	3.00	12.34	-43.37	-13.00	30.37	V
5554.5	-54.43	5.31	3.00	13.52	-46.22	-13.00	33.22	V

*LTE FDD Band 2\_Channel Bandwidth 3MHz\_16QAM\_Middle Channel*

Frequency (MHz)	P <sub>Mea</sub> (dBm)	P <sub>cl</sub> (dB)	Diatance	G <sub>a</sub> Antenna Gain(dB)	Peak EIRP (dBm)	Limit (dBm)	Margin (dB)	Polarization
3760.0	-42.93	4.41	3.00	12.34	-35.00	-13.00	22.00	H
5640.0	-47.94	5.38	3.00	13.58	-39.74	-13.00	26.74	H
3760.0	-49.83	4.41	3.00	12.34	-41.90	-13.00	28.90	V
5640.0	-53.21	5.38	3.00	13.58	-45.01	-13.00	32.01	V

*LTE FDD Band 2\_Channel Bandwidth 3MHz\_16QAM\_High Channel*

Frequency (MHz)	P <sub>Mea</sub> (dBm)	P <sub>cl</sub> (dB)	Diatance	G <sub>a</sub> Antenna Gain(dB)	Peak EIRP (dBm)	Limit (dBm)	Margin (dB)	Polarization
3817.0	-44.89	4.45	3.00	12.45	-36.89	-13.00	23.89	H
5725.5	-50.42	5.47	3.00	13.66	-42.23	-13.00	29.23	H
3817.0	-49.94	4.45	3.00	12.45	-41.94	-13.00	28.94	V
5725.5	-56.29	5.48	3.00	13.66	-48.11	-13.00	35.11	V

*LTE FDD Band 2\_Channel Bandwidth 5MHz\_16QAM\_Low Channel*

Frequency (MHz)	P <sub>Mea</sub> (dBm)	P <sub>cl</sub> (dB)	Diatance	G <sub>a</sub> Antenna Gain(dB)	Peak EIRP (dBm)	Limit (dBm)	Margin (dB)	Polarization
3705.0	-47.00	4.39	3.00	12.34	-39.05	-13.00	26.05	H
5557.5	-50.18	5.31	3.00	13.52	-41.97	-13.00	28.97	H
3705.0	-52.31	4.39	3.00	12.34	-44.36	-13.00	31.36	V
5557.5	-55.10	5.31	3.00	13.52	-46.89	-13.00	33.89	V

*LTE FDD Band 2\_Channel Bandwidth 5MHz\_16QAM\_Middle Channel*

Frequency (MHz)	P <sub>Mea</sub> (dBm)	P <sub>cl</sub> (dB)	Diatance	G <sub>a</sub> Antenna Gain(dB)	Peak EIRP (dBm)	Limit (dBm)	Margin (dB)	Polarization
3760.0	-42.48	4.41	3.00	12.34	-34.55	-13.00	21.55	H
5640.0	-47.98	5.38	3.00	13.58	-39.78	-13.00	26.78	H
3760.0	-50.33	4.41	3.00	12.34	-42.40	-13.00	29.40	V
5640.0	-53.03	5.38	3.00	13.58	-44.83	-13.00	31.83	V

*LTE FDD Band 2\_Channel Bandwidth 5MHz\_16QAM\_High Channel*

Frequency (MHz)	P <sub>Mea</sub> (dBm)	P <sub>cl</sub> (dB)	Diatance	G <sub>a</sub> Antenna Gain(dB)	Peak EIRP (dBm)	Limit (dBm)	Margin (dB)	Polarization
3815.0	-45.67	4.45	3.00	12.45	-37.67	-13.00	24.67	H
5722.5	-49.61	5.47	3.00	13.66	-41.42	-13.00	28.42	H
3815.0	-50.42	4.45	3.00	12.45	-42.42	-13.00	29.42	V
5722.5	-56.86	5.48	3.00	13.66	-48.68	-13.00	35.68	V

*LTE FDD Band 2\_Channel Bandwidth 10MHz\_16QAM\_Low Channel*

Frequency (MHz)	P <sub>Mea</sub> (dBm)	P <sub>cl</sub> (dB)	Diatance	G <sub>a</sub> Antenna Gain(dB)	Peak EIRP (dBm)	Limit (dBm)	Margin (dB)	Polarization
3710.0	-46.73	4.39	3.00	12.34	-38.78	-13.00	25.78	H
5565.0	-50.07	5.31	3.00	13.52	-41.86	-13.00	28.86	H
3710.0	-55.04	4.39	3.00	12.34	-47.09	-13.00	34.09	V
5565.0	-56.52	5.31	3.00	13.52	-48.31	-13.00	35.31	V

*LTE FDD Band 2\_Channel Bandwidth 10MHz\_16QAM\_Middle Channel*

Frequency (MHz)	P <sub>Mea</sub> (dBm)	P <sub>cl</sub> (dB)	Diatance	G <sub>a</sub> Antenna Gain(dB)	Peak EIRP (dBm)	Limit (dBm)	Margin (dB)	Polarization
3760.0	-41.89	4.41	3.00	12.34	-33.96	-13.00	20.96	H
5640.0	-48.34	5.38	3.00	13.58	-40.14	-13.00	27.14	H
3760.0	-49.13	4.41	3.00	12.34	-41.20	-13.00	28.20	V
5640.0	-53.44	5.38	3.00	13.58	-45.24	-13.00	32.24	V



*LTE FDD Band 2\_Channel Bandwidth 10MHz\_16QAM\_High Channel*

Frequency (MHz)	P <sub>Mea</sub> (dBm)	P <sub>cl</sub> (dB)	Diatance	G <sub>a</sub> Antenna Gain(dB)	Peak EIRP (dBm)	Limit (dBm)	Margin (dB)	Polarization
3810.0	-45.55	4.45	3.00	12.45	-37.55	-13.00	24.55	H
5715.0	-51.03	5.47	3.00	13.66	-42.84	-13.00	29.84	H
3810.0	-51.79	4.45	3.00	12.45	-43.79	-13.00	30.79	V
5715.0	-56.22	5.48	3.00	13.66	-48.04	-13.00	35.04	V

*LTE FDD Band 2\_Channel Bandwidth 15MHz\_16QAM\_Low Channel*

Frequency (MHz)	P <sub>Mea</sub> (dBm)	P <sub>cl</sub> (dB)	Diatance	G <sub>a</sub> Antenna Gain(dB)	Peak EIRP (dBm)	Limit (dBm)	Margin (dB)	Polarization
3715.0	-47.71	4.39	3.00	12.34	-39.76	-13.00	26.76	H
5572.5	-50.95	5.31	3.00	13.52	-42.74	-13.00	29.74	H
3715.0	-54.50	4.39	3.00	12.34	-46.55	-13.00	33.55	V
5572.5	-56.15	5.31	3.00	13.52	-47.94	-13.00	34.94	V

*LTE FDD Band 2\_Channel Bandwidth 15MHz\_16QAM\_Middle Channel*

Frequency (MHz)	P <sub>Mea</sub> (dBm)	P <sub>cl</sub> (dB)	Diatance	G <sub>a</sub> Antenna Gain(dB)	Peak EIRP (dBm)	Limit (dBm)	Margin (dB)	Polarization
3760.0	-42.60	4.41	3.00	12.34	-34.67	-13.00	21.67	H
5640.0	-49.02	5.38	3.00	13.58	-40.82	-13.00	27.82	H
3760.0	-51.40	4.41	3.00	12.34	-43.47	-13.00	30.47	V
5640.0	-54.69	5.38	3.00	13.58	-46.49	-13.00	33.49	V

*LTE FDD Band 2\_Channel Bandwidth 15MHz\_16QAM\_High Channel*

Frequency (MHz)	P <sub>Mea</sub> (dBm)	P <sub>cl</sub> (dB)	Diatance	G <sub>a</sub> Antenna Gain(dB)	Peak EIRP (dBm)	Limit (dBm)	Margin (dB)	Polarization
3805.0	-47.59	4.45	3.00	12.45	-39.59	-13.00	26.59	H
5707.5	-51.54	5.47	3.00	13.66	-43.35	-13.00	30.35	H
3805.0	-51.28	4.45	3.00	12.45	-43.28	-13.00	30.28	V
5707.5	-57.95	5.48	3.00	13.66	-49.77	-13.00	36.77	V

*LTE FDD Band 2\_Channel Bandwidth 20MHz\_16QAM\_Low Channel*

Frequency (MHz)	P <sub>Mea</sub> (dBm)	P <sub>cl</sub> (dB)	Diatance	G <sub>a</sub> Antenna Gain(dB)	Peak EIRP (dBm)	Limit (dBm)	Margin (dB)	Polarization
3715.0	-50.63	4.39	3.00	12.34	-42.68	-13.00	29.68	H
5572.5	-51.80	5.31	3.00	13.52	-43.59	-13.00	30.59	H
3715.0	-54.69	4.39	3.00	12.34	-46.74	-13.00	33.74	V
5572.5	-57.30	5.31	3.00	13.52	-49.09	-13.00	36.09	V

*LTE FDD Band 2\_Channel Bandwidth 20MHz\_16QAM\_Middle Channel*

Frequency (MHz)	P <sub>Mea</sub> (dBm)	P <sub>cl</sub> (dB)	Diatance	G <sub>a</sub> Antenna Gain(dB)	Peak EIRP (dBm)	Limit (dBm)	Margin (dB)	Polarization
3720.0	-42.44	4.41	3.00	12.34	-34.51	-13.00	21.51	H
5580.0	-48.67	5.38	3.00	13.58	-40.47	-13.00	27.47	H
3720.0	-51.44	4.41	3.00	12.34	-43.51	-13.00	30.51	V
5580.0	-54.22	5.38	3.00	13.58	-46.02	-13.00	33.02	V

*LTE FDD Band 2\_Channel Bandwidth 20MHz\_16QAM\_High Channel*

Frequency (MHz)	P <sub>Mea</sub> (dBm)	P <sub>cl</sub> (dB)	Diatance	G <sub>a</sub> Antenna Gain(dB)	Peak EIRP (dBm)	Limit (dBm)	Margin (dB)	Polarization
3800.0	-48.42	4.45	3.00	12.45	-40.42	-13.00	27.42	H
5700.0	-52.55	5.47	3.00	13.66	-44.36	-13.00	31.36	H
3800.0	-52.25	4.45	3.00	12.45	-44.25	-13.00	31.25	V
5700.0	-58.11	5.48	3.00	13.66	-49.93	-13.00	36.93	V

## 4.7 Frequency Stability

### LIMIT

According to §24.235, §2.1055 requirement, the frequency stability shall be sufficient to ensure that the fundamental emissions stay within the authorized bands of operation and should not exceed 2.5ppm.

### TEST CONFIGURATION

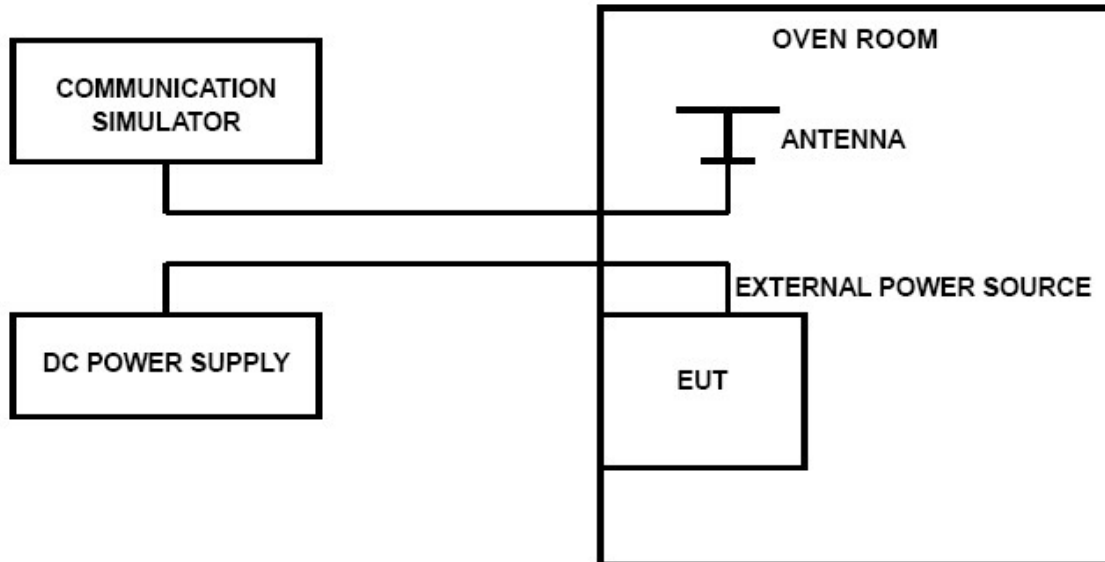

### TEST PROCEDURE

The EUT was setup according to EIA/TIA 603D

#### **Frequency Stability Under Temperature Variations:**

In order to measure the carrier frequency under the condition of AFC lock, it is necessary to make measurements with the EUT in a "call mode". This is accomplished with the use of R&S CMW500 DIGITAL RADIO COMMUNICATION TESTER.

1. Measure the carrier frequency at room temperature.
2. Subject the EUT to overnight soak at -30°C.
3. With the EUT, powered via nominal voltage, connected to the CMW500 and in a simulated call on middle channel for LTE band 2, measure the carrier frequency. These measurements should be made within 2 minutes of Powering up the EUT, to prevent significant self-warming.
4. Repeat the above measurements at 10°C increments from -30°C to +50°C. Allow at least 1.5 hours at each temperature, unpowered, before making measurements.
5. Re-measure carrier frequency at room temperature with nominal voltage. Vary supply voltage from minimum voltage to maximum voltage, in 0.1Volt increments re-measuring carrier frequency at each voltage. Pause at nominal voltage for 1.5 hours unpowered, to allow any self-heating to stabilize, before continuing.
6. Subject the EUT to overnight soak at +50°C.
7. With the EUT, powered via nominal voltage, connected to the CMW500 and in a simulated call on the centre channel, measure the carrier frequency. These measurements should be made within 2 minutes of Powering up the EUT, to prevent significant self-warming.
8. Repeat the above measurements at 10 °C increments from +50°C to -30°C. Allow at least 1.5 hours at each temperature, unpowered, before making measurements
9. At all temperature levels hold the temperature to +/- 0.5°C during the measurement procedure.

#### **Frequency Stability Under Voltage Variations:**

Set chamber temperature to 20°C. Use a variable AC power supply / DC power source to power the EUT and set the voltage to rated voltage. Set the spectrum analyzer RBW low enough to obtain the desired frequency resolution and recorded the frequency.

Reduce the input voltage to specify extreme voltage variation ( $\pm 15\%$ ) and endpoint, record the maximum frequency change.

**TEST RESULTS**

Remark:

1. We tested all RB Configuration refer 3GPP TS136 521 for each Channel Bandwidth of LTE FDD Band 2; recorded worst case.

LTE Band 2, 1.4MHz bandwidth , QPSK (worst case of all bandwidths)

<b>LTE FDD Band 2</b>					
<b>DC Power</b>	<b>Temperature (°C)</b>	<b>Frequency error(Hz)</b>	<b>Frequency error(ppm)</b>	<b>Limit (ppm)</b>	<b>Verdict</b>
3.40	20	28	0.0149	2.50	PASS
3.60	20	35	0.0186	2.50	PASS
4.20	20	17	0.0090	2.50	PASS
3.60	-30	26	0.0138	2.50	PASS
3.60	-20	17	0.0090	2.50	PASS
3.60	-10	20	0.0106	2.50	PASS
3.60	0	28	0.0149	2.50	PASS
3.60	10	21	0.0112	2.50	PASS
3.60	20	18	0.0096	2.50	PASS
3.60	30	27	0.0144	2.50	PASS
3.60	40	19	0.0101	2.50	PASS
3.60	50	25	0.0133	2.50	PASS

LTE Band 2, 1.4MHz bandwidth , 16QAM (worst case of all bandwidths)

<b>LTE FDD Band 2</b>					
<b>DC Power</b>	<b>Temperature (°C)</b>	<b>Frequency error(Hz)</b>	<b>Frequency error(ppm)</b>	<b>Limit (ppm)</b>	<b>Verdict</b>
3.40	20	38	0.0202	2.50	PASS
3.60	20	47	0.0250	2.50	PASS
4.20	20	52	0.0277	2.50	PASS
3.60	-30	61	0.0324	2.50	PASS
3.60	-20	37	0.0197	2.50	PASS
3.60	-10	42	0.0223	2.50	PASS
3.60	0	39	0.0207	2.50	PASS
3.60	10	25	0.0133	2.50	PASS
3.60	20	29	0.0154	2.50	PASS
3.60	30	35	0.0186	2.50	PASS
3.60	40	27	0.0144	2.50	PASS
3.60	50	22	0.0117	2.50	PASS

\*\*\*\*\*End of Report\*\*\*\*\*