



Test Report for FCC

FCC ID : 2AL6N-WPAD01

Report Number		ESTRFC1901-004			
Applicant	Company name	SALTED VENTURE Co., Ltd.			
	Address	Jungdo Building-3rd floor, 340, Nonhyeon-ro, Gangnam-gu Seoul South Korea			
	Telephone	+82-02-552-0815			
Product	Product name	Smart Shoes Wireless charger			
	Model No.	SV-WPAD01	Manufacturer	SALTED VENTURE Co., Ltd.	
	Serial No.	NONE	Country of origin	KOREA	
Test date	21-Dec-18 ~ 28-Dec-18		Date of issue	28-Jan-19	
Testing location	347-69, Jungbu-daero 147beon-gil, Majang-myeon, Icheon-si, Gyeonggi-do 467-811, R. O. Korea				
Standard	FCC PART 15 Subpart C(15.209), ANSI C 63.10(2013)				
Test item	<input checked="" type="checkbox"/> Conducted Emission	<input type="checkbox"/> Class A	<input checked="" type="checkbox"/> Class B	Test result	OK
	<input checked="" type="checkbox"/> Radiated Emission	<input type="checkbox"/> Class A	<input checked="" type="checkbox"/> Class B	Test result	OK
Measurement facility registration number	659627				
Tested by	Engineer H.G. Lee		(Signature)		
Reviewed by	Engineering Manager I.K. Hong		(Signature)		
Abbreviation	OK, Pass = Complied, Fail = Failed, N/A = not applicable				
<p>* Note</p> <ul style="list-style-type: none"> - This test report is not permitted to copy partly without our permission - This test result is dependent on only equipment to be used - This test result based on a single evaluation of one sample of the above mentioned 					



Contents

1. Laboratory Information	3
2. Description of EUT	4
3. Test Standards	5
4. Measurement condition	6
5. 20 dB Bandwidth.....	8
5.1 Radiated emission limits, general requirements	8
5.2 Measurement equipment	8
5.3 Environmental conditions	8
5.4 Test data	9
6. Measurement of radiated emission	10
6.1 Radiated emission limits, general requirements	10
6.2 Measurement equipment	10
6.3 Environmental conditions	10
6.4 Test data	11
7. Measurement of conducted emission	13
7.1 Measurement equipment	13
7.2 Environmental conditions	13
7.3 Test data	14
8. Photographs of test setup	15
9. Photographs of EUT	17

Appendix 1. Special diagram

Appendix 2. Antenna Requirement



1. Laboratory Information

1.1 General

This EUT (Equipment Under Test) has been shown to be capable of compliance with the applicable technical standards and is tested in accordance with the measurement procedures as indicated in this report. ESTECH Lab attests to accuracy of test data. All measurement reported herein were performed by ESTECH Co., Ltd.

ESTECH Lab assume full responsibility for the completeness of these measurements and vouch for the qualifications of all persons taking them.

1.2 Test Lab.

Corporation Name : ESTECH Co., Ltd.

Head Office : Suite 1015 World Meridian II, 123 Gasan Digital 2-ro, Geumcheon-gu,
Seoul 153-759, R. O. Korea

EMC/Telecom/Safety Test Lab : 347-69, Jungbu-daero 147beon-gil, Majang-myeon, Icheon-si,
Gyeonggi-do 467-811, R. O. Korea

1.3 Official Qualification(s)

KCC : Granted Accreditation from Ministry of Information & Communication for EMC, Safety
and Telecommunication

KOLAS : Accredited Lab By Korea Laboratory Accreditation Schema base on CENELEC

FCC : Filed Laboratory at Federal Communications Commission

VCCI : Granted Accreditation from Voluntary Control Council for Interference from ITE



2. Description of EUT

2.1 Summary of Equipment Under Test

Product : Smart Shoes Wireless charger
 Model Number : SV-WPAD01
 Serial Number : NONE
 Manufacturer : SALTED VENTURE Co., Ltd.
 Country of origin : KOREA
 Operating Frequency : 130 kHz
 Antenna Type : Coil Antenna
 Modulation Type : ASK
 Channel Spacing : 1

 Power Rating : Input:100-240 V AC 50/60 Hz 0.3A
 : Output: DC 5 V 2000 mA

 Receipt Date : 1-Aug-18
 X-tal list(s) or Frequencies generated : The highest operating frequency is 130 kHz

2.2 General descriptions of EUT

User Scenario	Status	LED Light Indicator
When Charging	Low Battery	Red LED light flashes
	Normal Battrey	Yello LED light flashes
	High Battrey	Sky LED light flashes
Fully charged		LED light



3. Test Standards

Test Standard : FCC PART 15

This Standard sets out the regulations under which an intentional, unintentional, or incidental radiator may be operated without an individual license. It also contains the technical specifications, administrative requirements and other conditions relating to the marketing of Part 15 devices.

Test Method : ANSI C 63.10 (2013)

This standard sets forth uniform methods of measurement of radio-frequency (RF) signals and noise emitted from both unintentional and intentional emitters of RF energy in the frequency range 9 kHz to 40 GHz. Methods for the measurement of radiated and AC power-line conducted radio noise are covered and may be applied to any such equipment unless otherwise specified by individual equipment requirements. These methods cover measurement of certain devices that deliberately radiate energy, such as intentional emitters, but does not cover licensed transmitters. This standard is not intended for certification/approval of avionic equipment or for industrial, scientific, and medical (ISM) equipment. These methods apply to the measurement of individual units or systems comprised of multiple units.

Summary of Test Results

Applied Standard : 47 CFR Part 15, Subpart C				
Standard	Test Type	Result	Remark	Limit
15.203	Antenna Requirement	Pass	See Appendix 2	
2.1049	20 dB Bandwidth	Pass	Meet the requirement	
15.207	AC Power Conducted Emission	Pass	Meet the requirement	
15.209	Radiated Emission	Pass	Meet the requirement	

4. Measurement Condition

4.1 EUT Operation.

- The EUT was tested, under transmission / receiving
 1. Normal communication with RF OUT Frequency(130 kHz).
 2. Monitoring the operation status of frequency by using .Smart Shoes

4.2 Configuration and Peripherals

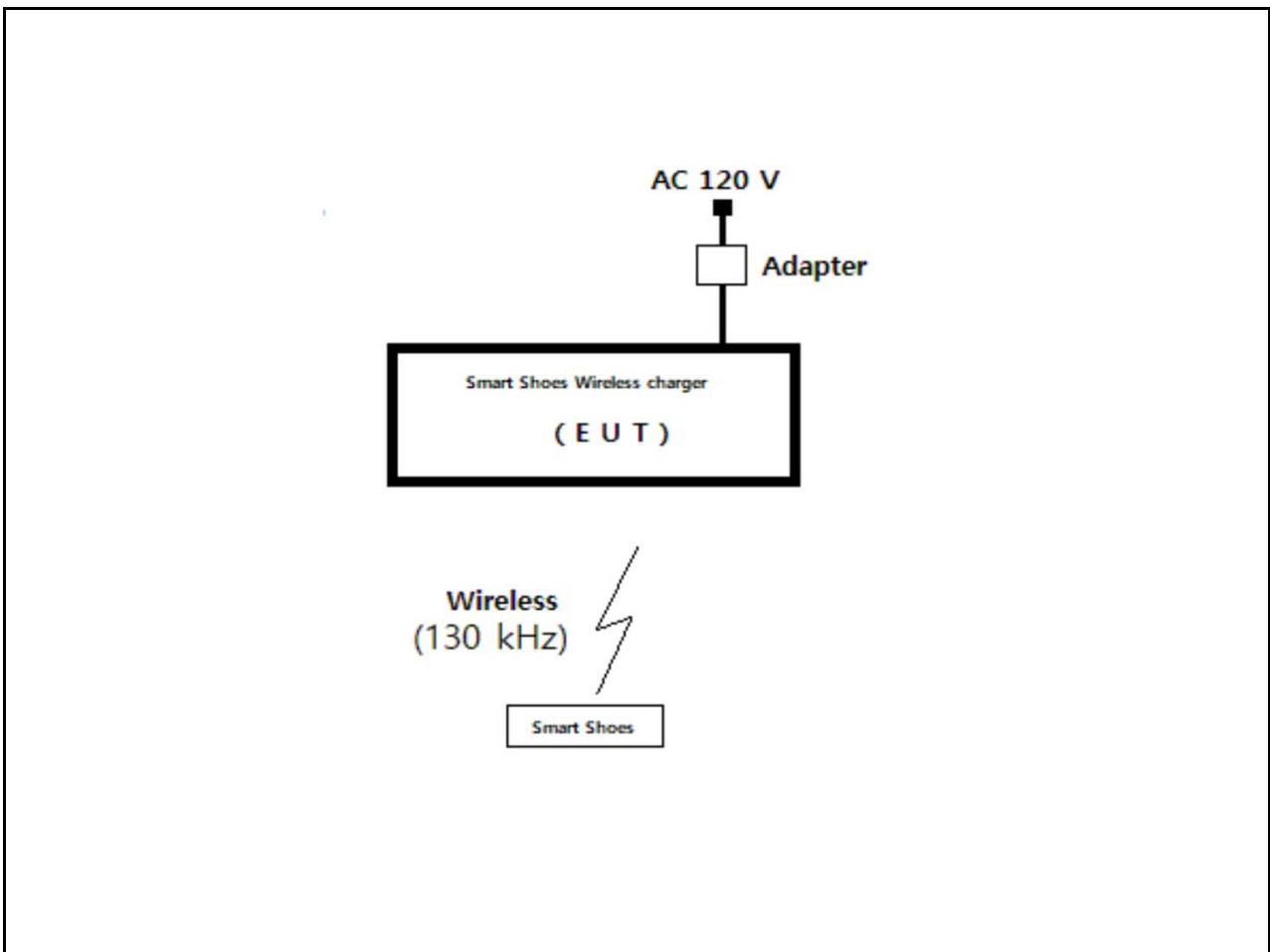

4.3 EUT and Support equipment

Equipment Name	Model Name	S/N	Manufacturer	Remark (FCC ID)
Smart Shoes Wireless charger	SV-WPAD01	NONE	SALTED VENTURE Co., Ltd.	EUT
Adapter	MKS-0502000SUEK	NONE	Shenzhen Merryking Electronics Co.,Ltd.	
Smart Shoes	FTW01-BK	NONE	SALTED VENTURE Co., Ltd.	

4.4 Cable Connecting

Start Equipment		End Equipment		Cable Standard		Remark
Name	I/O port	Name	I/O port	Length	Shielded	
Smart Shoes Wireless charger	Power	Adapter	-	2	Unshielded	
Smart Shoes Wireless charger	Wireless (130 kHz)	Smart Shoes	Wireless (130 kHz)	-	-	

5. 20dB bandwidth

5.1 Test Procedure

- a. Span = approximately 2 to 3 times the 20 dB bandwidth, RBW = greater than 1 % of the 20 dB bandwidth, VBW = RBW, Sweep = auto, Detector = peak, Trace = max hold.
- b. The marker-to-peak function to set the mark to the peak of the emission. Use the marker-delta function to measure 20 dB down one side of the emission. Reset the function, and move the marker to the other side of the emission, until it is (as close as possible to) even with the reference marker level. The marker-delta reading at this point is 20 dB bandwidth of the emission.

5.2 Test Setup

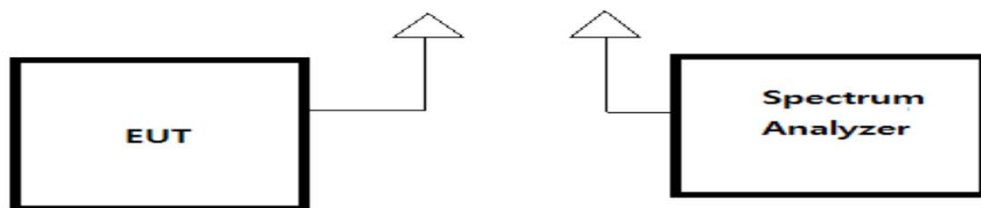

5.3 Limit

None; for reporting purposed only

5.4 Test Result

Ambient temperature 23 °C

Relative humidity 46 % R.H.

Test condition : Normal charging mode with Smart Wearable Device

EUT status	20 dB Bandwidth (kHz)	Limit
With client device (100 % of battery)	0.506	Reporting proposed only

20 dB Bandwidth (With client device)

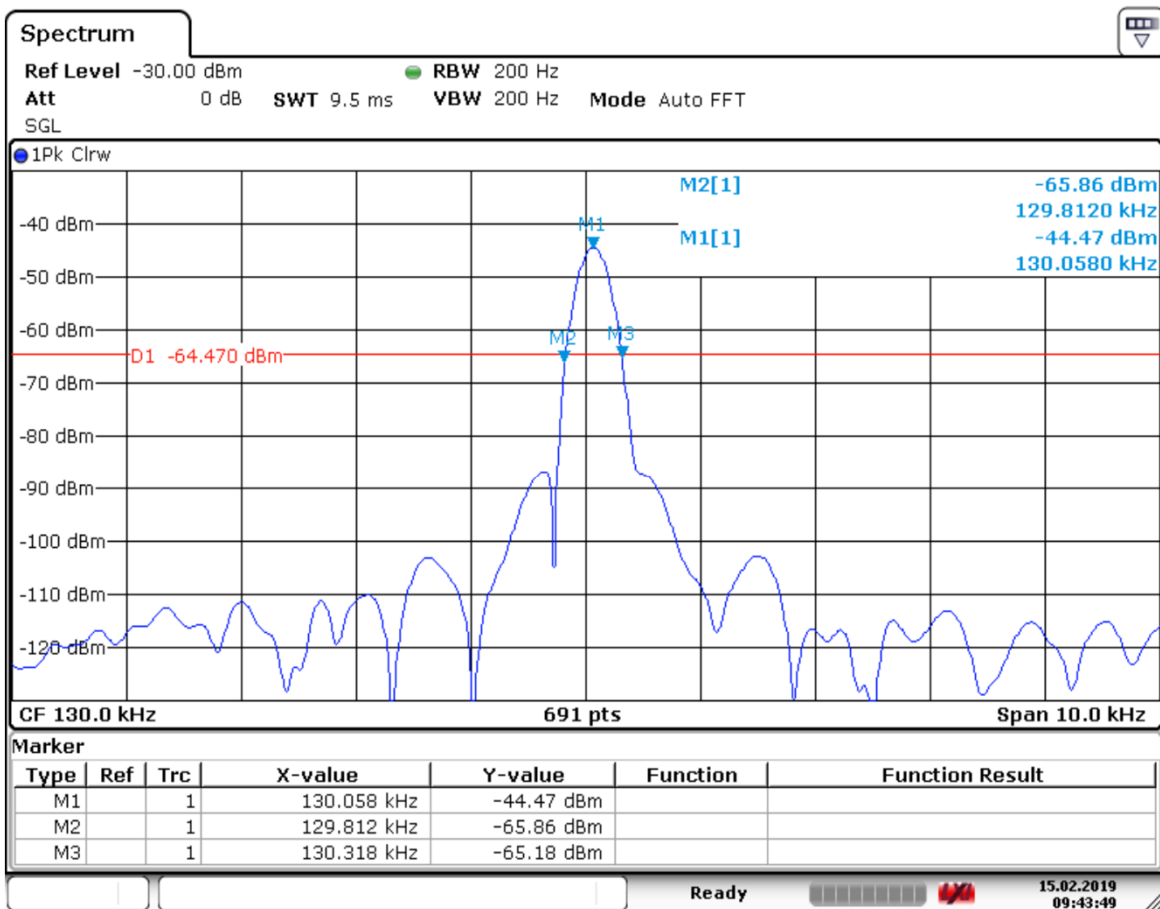

5. Measurement of radiated disturbance

The EUT was placed on the top of a rotating table 0.8 m above the ground at a 3 m Open test site. The table was rotated 360 ° to determine the position of the highest radiation. Then antenna is a loop antenna is fixed at one meter above the ground to determine the maximum value of the field strength. Both parallel and perpendicular of the antenna are set to make the measurement. For each suspected emission, the EUT was arranged to its worst case and then the table was turned from 0 degrees to 360 ° to find the maximum reading. The test-receiver system was set to Peak Detect Function and Specified Bandwidth with Maximum Hold Mode.

5.1 Radiated emission limits, general requirements

Except as provided elsewhere in this Subpart, the emissions from an intentional radiator shall not exceed the field strength levels specified in the following table:

Frequency (MHz)	Field Strength(microvolt/meter)	Distance(meter)
0.009–0.490	2400/F(KHz)	300
0.490–1.705	24000/F(KHz)	30
1.705–30	30	30
30–88	100**	3
88–216	150**	3
216–960	200**	3
Above 960	500	3

* dBuV/m=20*log(uV/m) * Distance factor=40dB / decade(15.31(f))

5.2 Measurement equipments

Equipment Name	Type	Manufacturer	Serial No.	Next Calibration date
TEST Receiver	ESC17	ROHDE & SCHWARZ	100916	22-Oct-19
Logbicon Antenna	VULB 9168	SCHWARZBECK	193	15-Oct-20
Turn Table	DT3000-2t	Innco System GmbH	N/A	-
Antenna Mast	MA4000-EP	Innco System GmbH	N/A	-
Antenna Master & Turn table controller	CO2000-P	Innco System GmbH	CO2000/641 /28051111/L	-
Loop Antenna	HFH2-Z2	ROHDE & SCHWARZ	100188	30-Apr-20

5.3 Environmental Condition

Test Place : 10 m Semi-anechoic chamber
 Temperature (°C) : 23.1 °C
 Humidity (%) : 47.5 % R.H.

5.4 Test data (9 kHz ~ 30 MHz)

Test Date : 28-Dec-18

Measurement Distance : 3 m

Frequency (kHz)	Reading (dB μ V)	Vertical Position [Angle]	Height (m)	Correction Factor		Result Value(Qeas-Peak)		
				Ant Factor (dB)	Cable (dB)	Limit (dB μ V/m)	Result (dB μ V/m)	Margin (dB)
130.00	38.52	190 °	1.0	11.56	1.72	105.3	51.80	-53.53
Remark	<p>H : Horizontal, V : Vertical There did not measure any radiated spurious emission in the range 9 kHz to 30 MHz *There is no found Restricted bands. *The 300 m limit was converted to 3m Limit using square factor(x) as it was found by measurements as follows: 3 m Limit(dBuV/m) = 20log(2400/F(KHz))+40log(300/3)= 20log(2400/130)+40log(300/3)</p>							

5.4 Test data(30 MHz ~ 1 000 MHz)

Test Date : 28-Dec-18

Measurement Distance : 3 m

Frequency (MHz)	Reading (dB μ V)	Position (V/H)	Height (m)	Correction Factor		Result Value(Quasi-peak)		
				Ant Factor (dB)	Cable (dB)	Limit (dB μ V/m)	Result (dB μ V/m)	Margin (dB)
59.31	10.54	V	1.0	13.29	1.14	40.00	24.97	15.03
64.10	10.26	V	1.0	12.70	1.20	40.00	24.16	15.84
216.60	12.06	H	1.4	10.65	2.26	46.00	24.96	21.04
227.60	8.89	H	1.3	11.07	2.32	46.00	22.28	23.72
335.50	4.64	V	1.2	14.49	2.86	46.00	22.00	24.00
349.40	5.17	H	1.3	14.84	2.93	46.00	22.94	23.06
Remark	H : Horizontal, V : Vertical *Result Value = Reading + Antenna + Cable loss *Correction Factor = Ant Factor + Cable *The resolution bandwidth and video bandwidth of test receiver/spectrum analyzer is 120 kHz for Quasi-peak detection							

6. Measurement of conducted disturbance

The continuous disturbance voltage of AC Mains in the frequency from 0.15 MHz to 30 MHz was measured in accordance to FCC Part 15 & ANSI C 63.10 (2013) The test setup was made according to FCC Part 15 & ANSI C 63.10 (2013) in a shielded Room. The EUT was placed on a non-conductive table at least 0.8 m above the ground plan. A grounded vertical reference plane was positioned in a distance of 0.4 m from the EUT. The distance from the EUT to other metal surfaces was at least 0.8 m. The EUT was only earthen by its power cord through the line impedance stabilizing network. The power cord has been bundled to a length of 1.0 m. The test receiver with Quasi Peak detector complies with CISPR 16.

6.1 Measurement equipments

Equipment Name	Type	Manufacturer	Serial No.	Next Calibration date
TEST Receiver	ESHS 30	Rohde & Schwarz	828765/002	24-Oct-19
LISN	ESH3-Z5	Rohde & Schwarz	836679/025	22-Oct-19
Pulse Limiter	ESH3Z2	Rohde & Schwarz	NONE	22-Oct-19

6.2 Environmental Condition

Test Place : Shielded Room

Temperature (°C) : 22.1 °C

Humidity (% R.H.) : 44.1 % R.H.



6.3 Test data

Test Date : 29-Dec-18

Frequency (MHz)	Correction Factor		Line (H/N)	Quasi-peak Value			Average Value		
	Lisn (dB)	Cable (dB)		Limit (dB μ V)	Reading (dB μ V)	Result (dB μ V)	Limit (dB μ V)	Reading (dB μ V)	Result (dB)
0.15	0.09	0.12	N	65.84	49.14	49.35	55.84	34.30	34.51
0.17	0.16	0.16	H	64.77	44.68	45.00	54.77	26.78	27.10
0.20	0.16	0.20	H	63.57	44.65	45.01	53.57	27.93	28.29
0.23	0.16	0.20	H	62.52	37.47	37.83	52.52	24.56	24.92
0.58	0.09	0.21	N	56.00	41.97	42.28	46.00	31.83	32.14
0.59	0.16	0.21	H	56.00	47.10	47.48	46.00	37.08	37.46
Remark	H : Hot Line, N : Neutral Line *Correction Factor = Lisn + Cable *Result = Correction Factor + Reading								

7. Photographs of test setup

7.1 Setup for Radiated Test

[Test setup for below 30 MHz]



[Test setup for above 30 MHz]





Estech
your best partner

7.2 Setup for Conducted Test : 0.15 MHz ~ 30 MHz

[Front]



[Rear]



8.0 Photographs of EUT

[Front]



[Rear]

