

Original Design Chip Antenna Data Sheet

- P/N : SDBTPTR3015 -

- Application Frequency	
	Band[MHz]
Bluetooth	2400 ~ 2485
WiFi / Zigbee	2400 ~ 2485
S-DMB	2630 ~ 2655
Wibro	2300 ~ 2390 band1 : 2300 ~ 2327 band2 : 2331.5 ~ 2358.5 bnad3 : 2363 ~ 2390

Dielectric Chip Antenna



■ SDBTPTR3015 Dimension

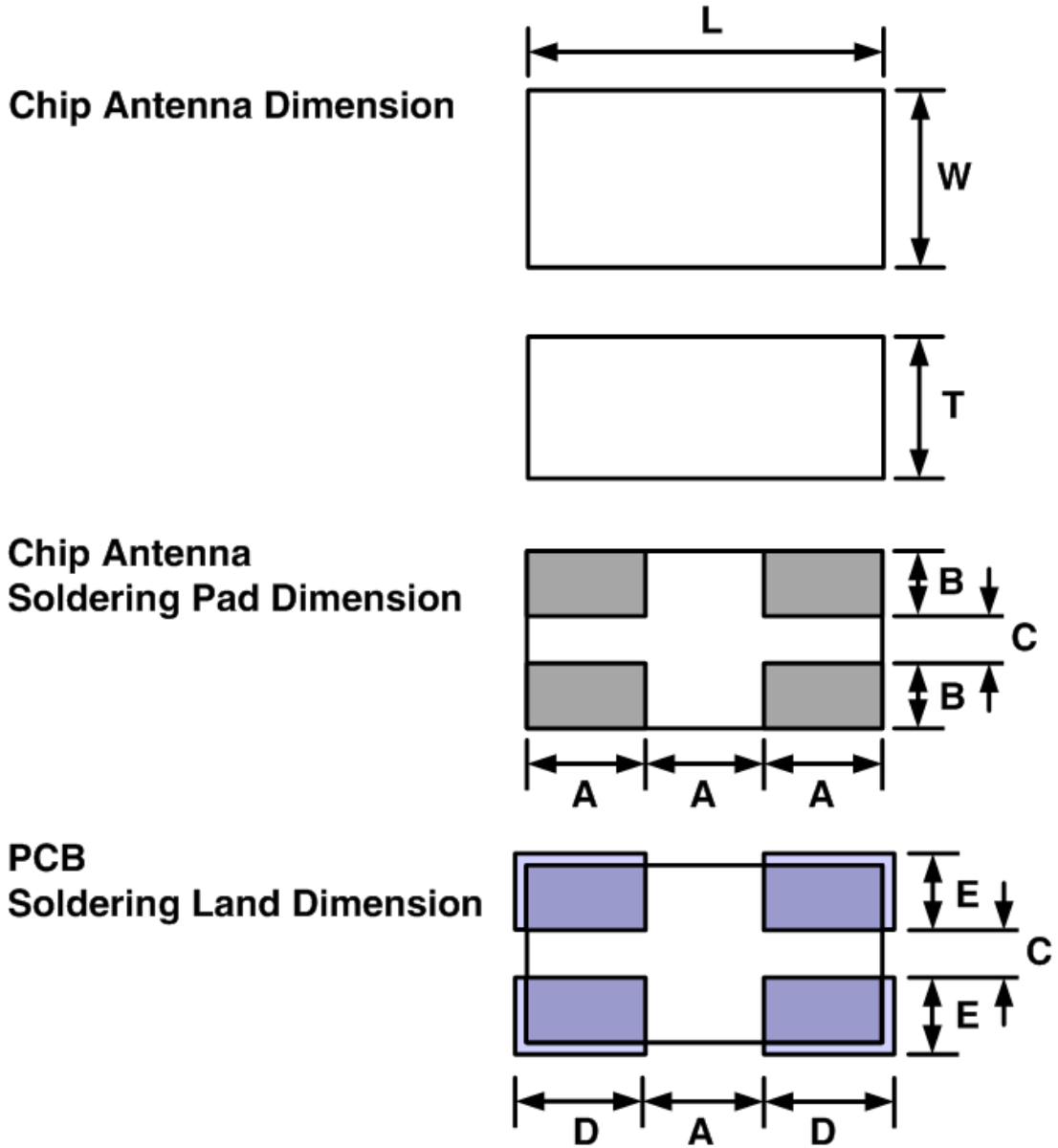

Parameter	L	W	T	A	B	C	D	E
Value[mm]	3.0 ± 0.1	1.5 ± 0.1	1.2 ± 0.1	1.0	0.55	0.4	1.1	0.65

Unless Specified tolerances are ± 0.05 mm

Dielectric Chip Antenna



Antenna Marking System

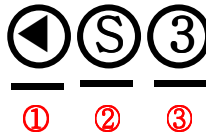

ITEM	DESCRIPTION																								
① Input Signal	Input Signal																								
② Serial	SDBTPTR3015																								
③ Month	<table border="1"> <thead> <tr> <th>1</th> <th>2</th> <th>3</th> <th>4</th> <th>5</th> <th>6</th> </tr> </thead> <tbody> <tr> <td>January</td> <td>February</td> <td>March</td> <td>April</td> <td>May</td> <td>June</td> </tr> <tr> <th>7</th> <th>8</th> <th>9</th> <th>A</th> <th>B</th> <th>C</th> </tr> <tr> <td>July</td> <td>August</td> <td>September</td> <td>October</td> <td>November</td> <td>December</td> </tr> </tbody> </table>	1	2	3	4	5	6	January	February	March	April	May	June	7	8	9	A	B	C	July	August	September	October	November	December
	1	2	3	4	5	6																			
	January	February	March	April	May	June																			
	7	8	9	A	B	C																			
July	August	September	October	November	December																				

Antenna PAD Information

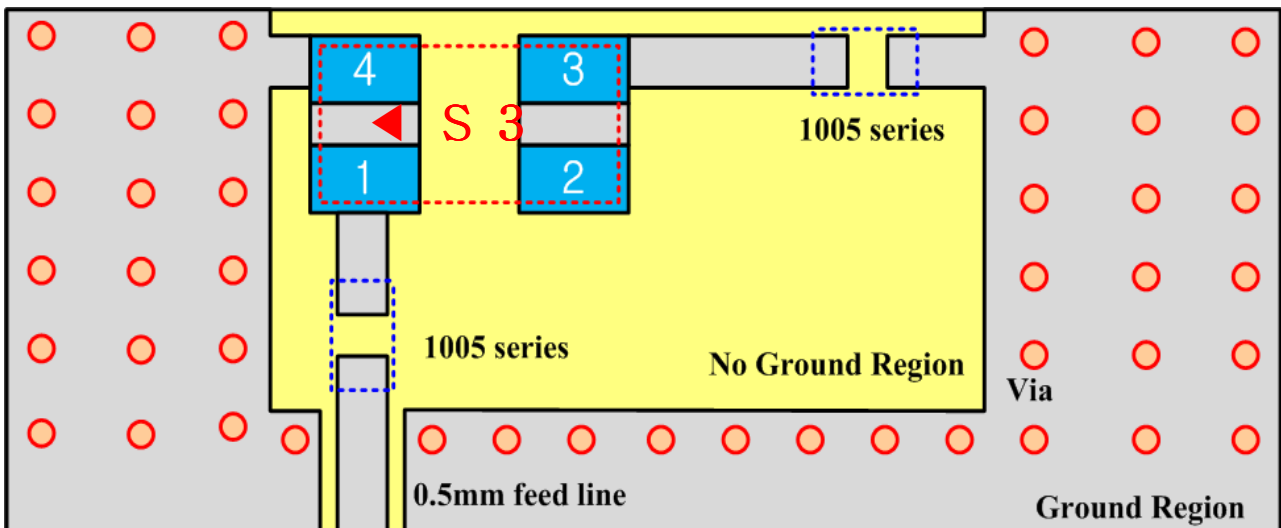

Dielectric Chip Antenna

■ AutoCAD Drawing of Reference PCB Design for SDBTPTR3015 Product

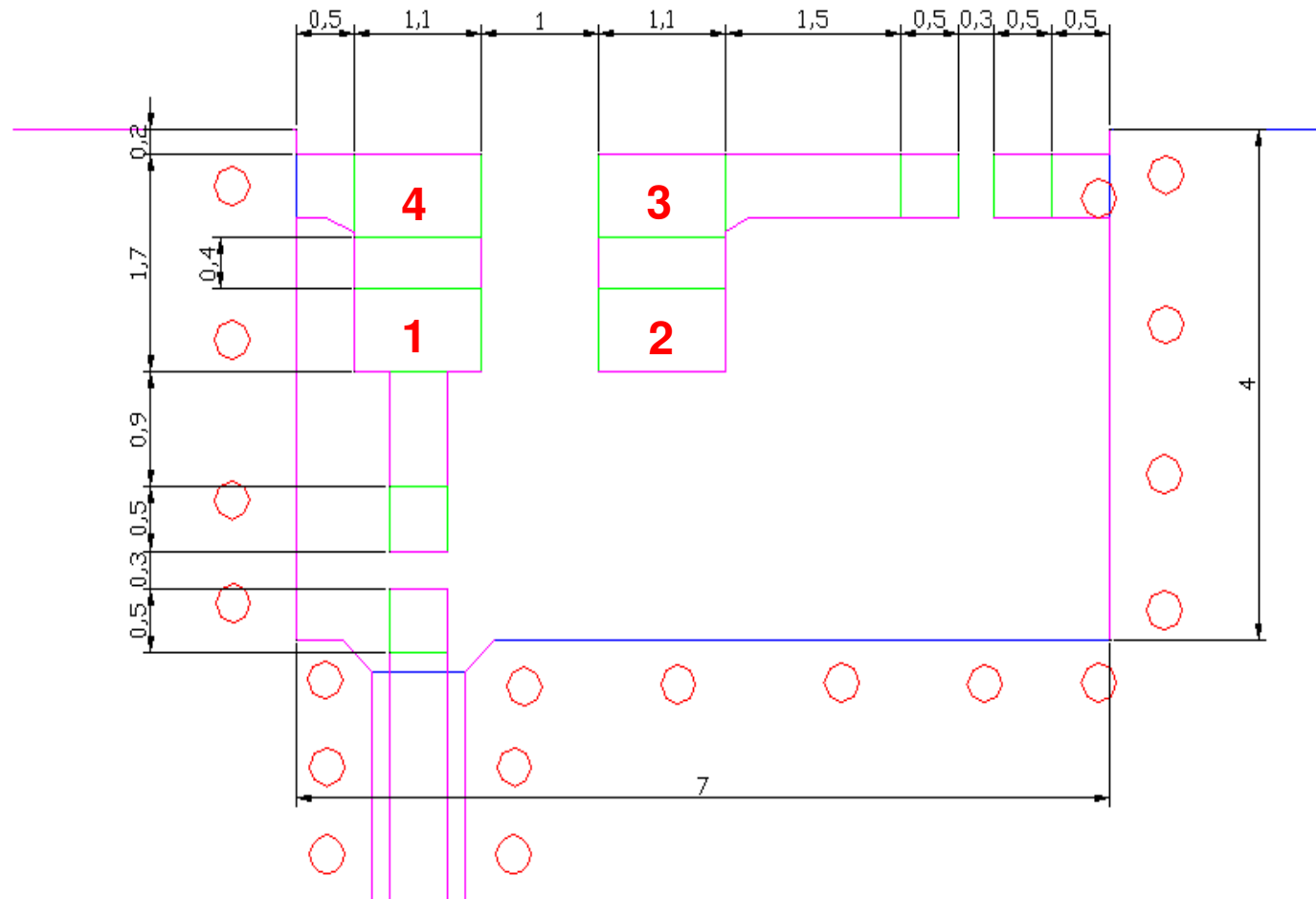

Dielectric Chip Antenna



PCB Drawing

Top View	Case #1 <Default>		
	Case #2		
	Case #3		
	Case #4		
	Bottom View		<Equivalent Circuit>

Dielectric Chip Antenna



■ Matching Value

Band (MHz)	Matching Value (Default)
<p>Bluetooth / WiFi / Zigbee (2400 ~ 2485)</p>	
<p>S-DMB (2630 ~ 2655)</p>	
<p>Wibro (2300 ~ 2390) band1:2300~2327 band2:2331.5~2358.5 band3:2363~2390</p>	

Dielectric Chip Antenna



- 3D Passive Gain For Bluetooth / WiFi / Zigbee

■ Test Result for Ver 0.0

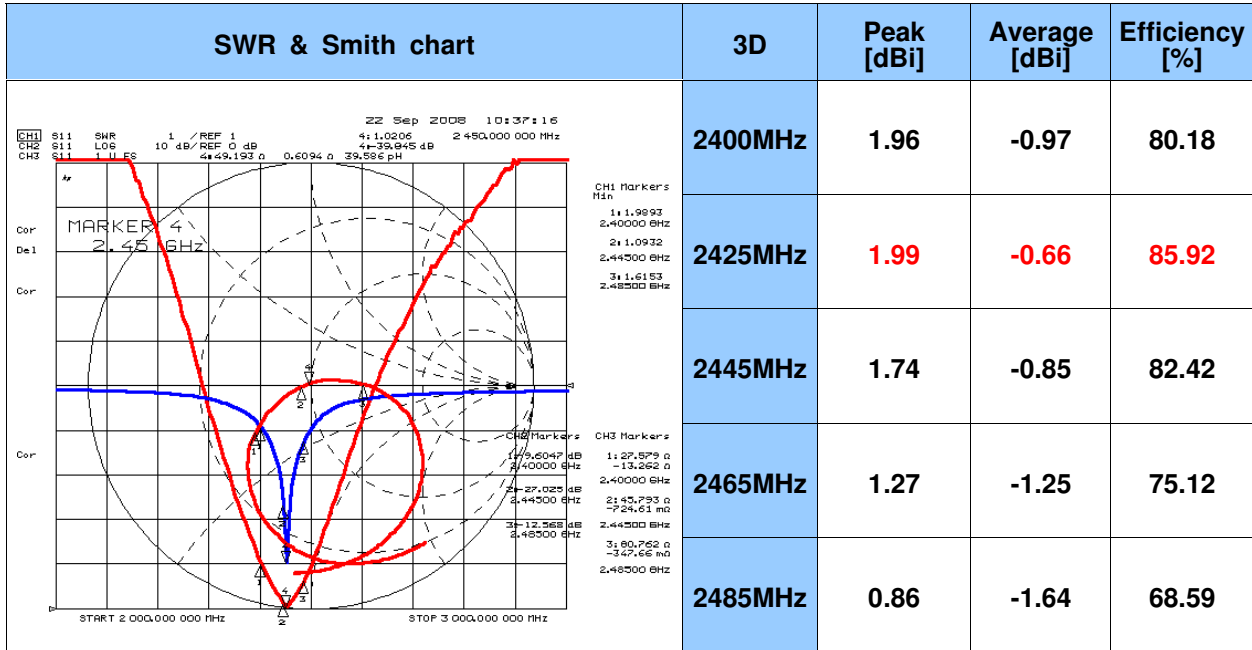

■ Radiation Pattern Ver 0.0

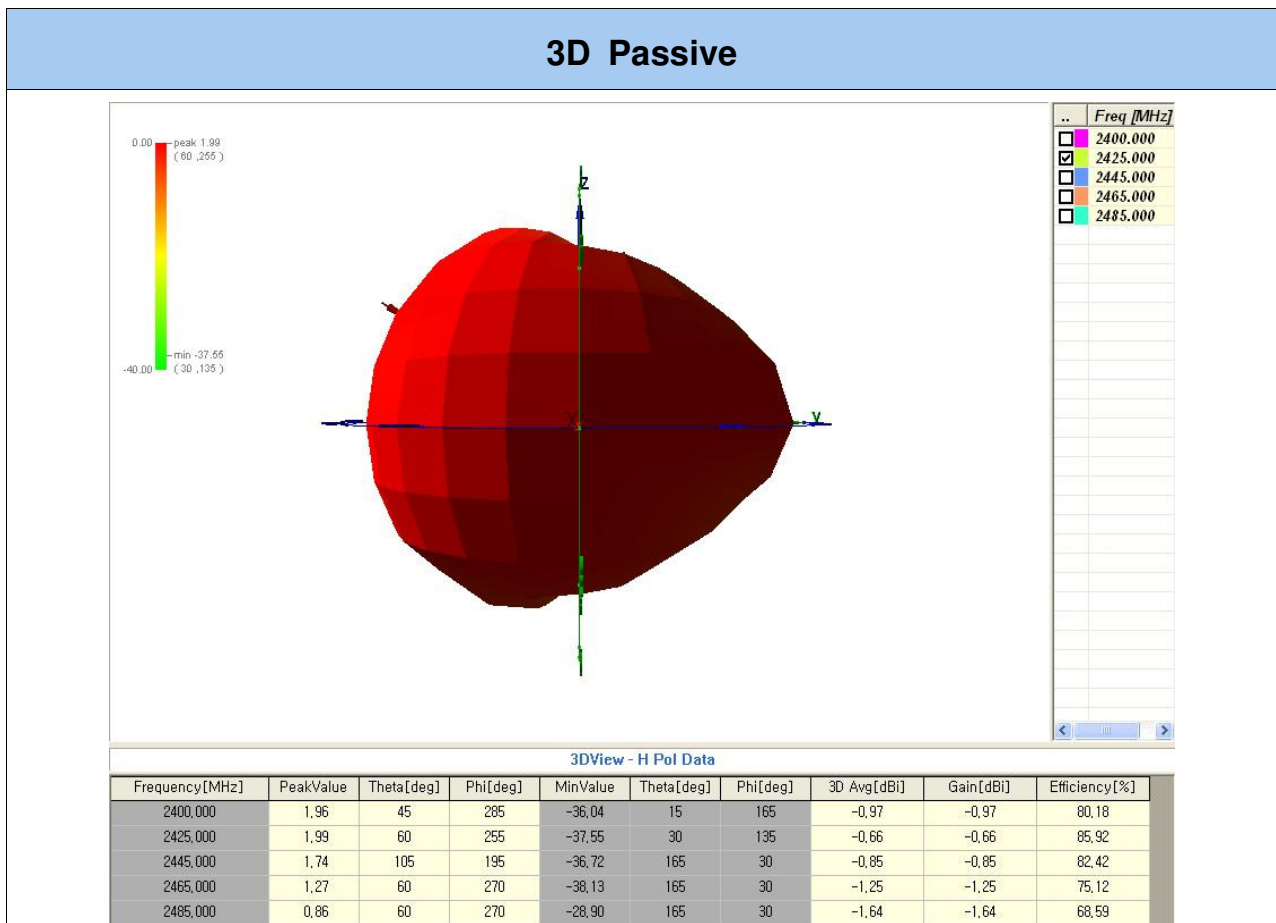

Dielectric Chip Antenna



- 3D Passive Gain For S-DMB

■ Test Result for Ver 0.0

SWR & Smith chart	3D	Peak [dBi]	Average [dBi]	Efficiency [%]
	2627MHz	4.33	-0.38	91.80
	2642MHz	4.67	-0.36	92.06
	2657MHz	4.71	-0.56	88.02

■ Radiation Pattern Ver 0.0

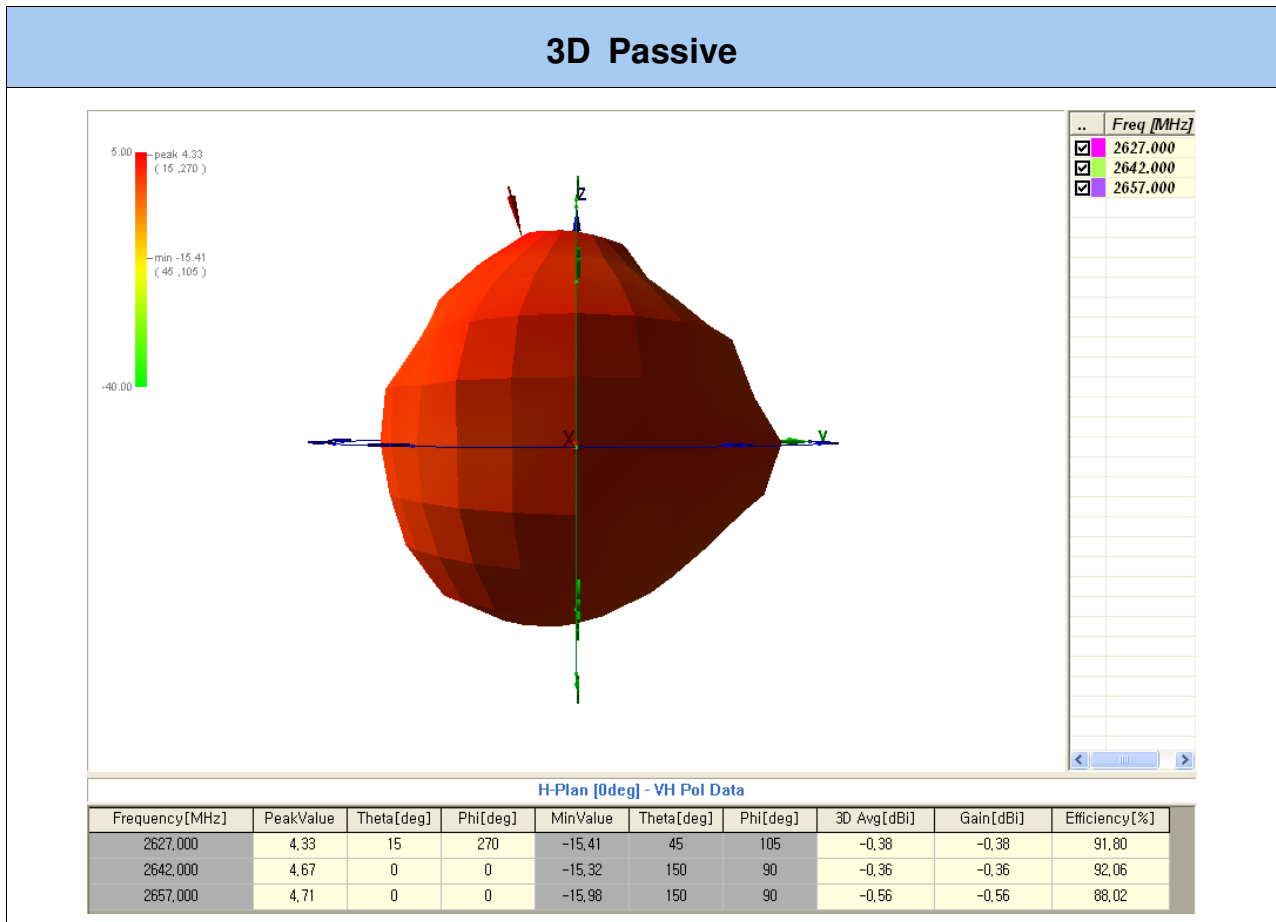

Dielectric Chip Antenna



- 3D Passive Gain For Wibro

■ Test Result for Ver 0.0

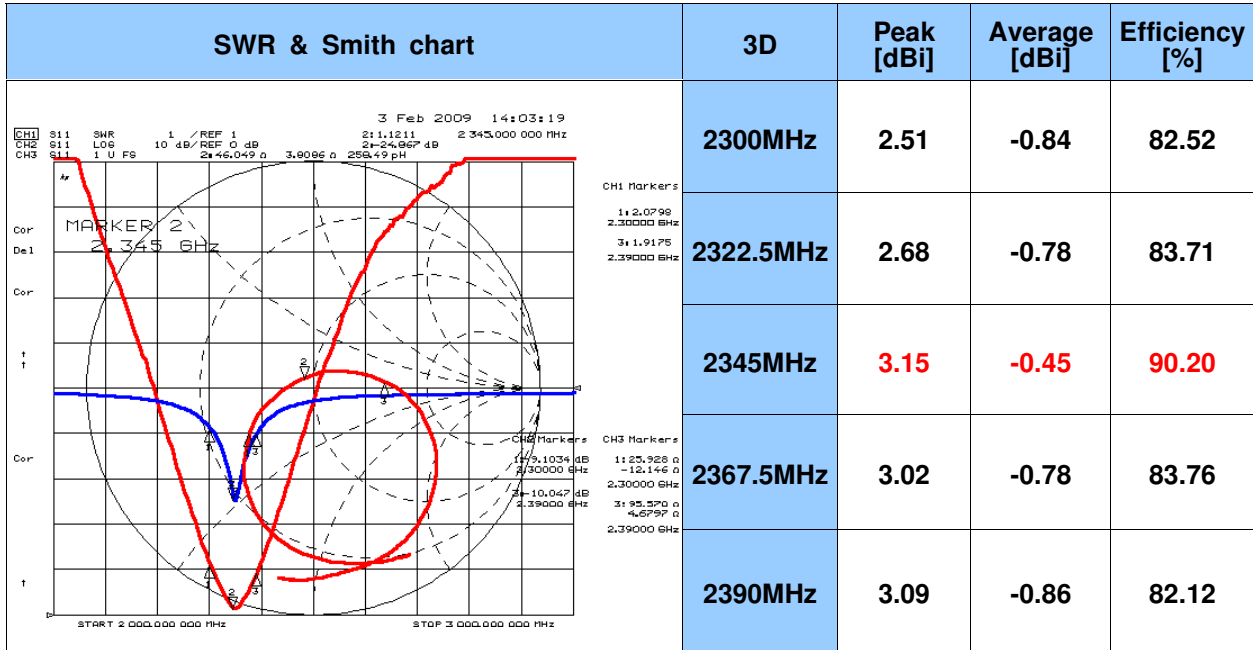

■ Radiation Pattern Ver 0.0

