

6dB Bandwidth

802.11a

802.11n HT20

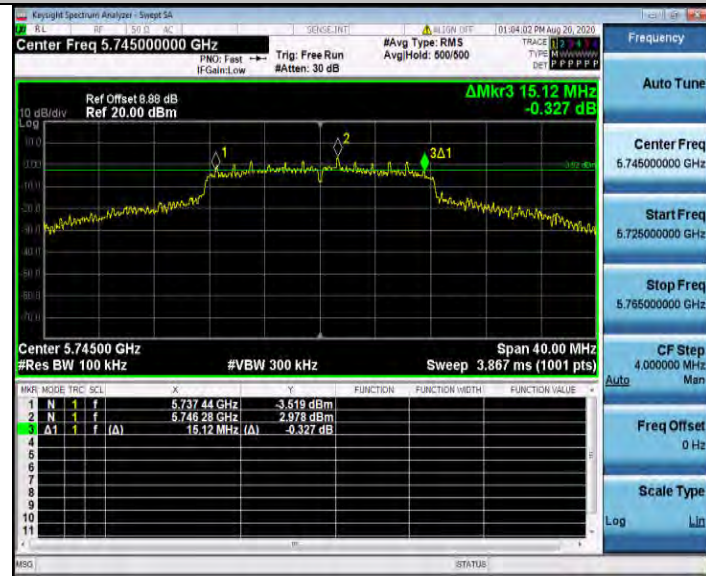

CH149

CH149



CH157

CH157



CH165

CH165



6dB Bandwidth

802.11ac20

802.11n HT40

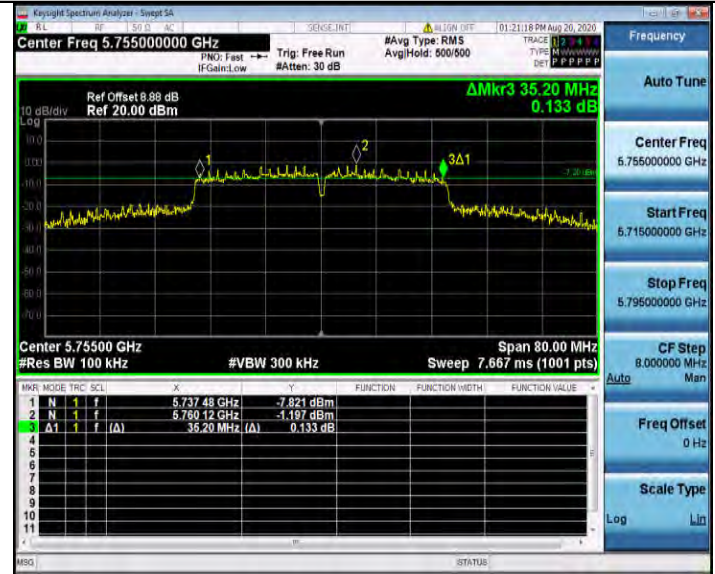
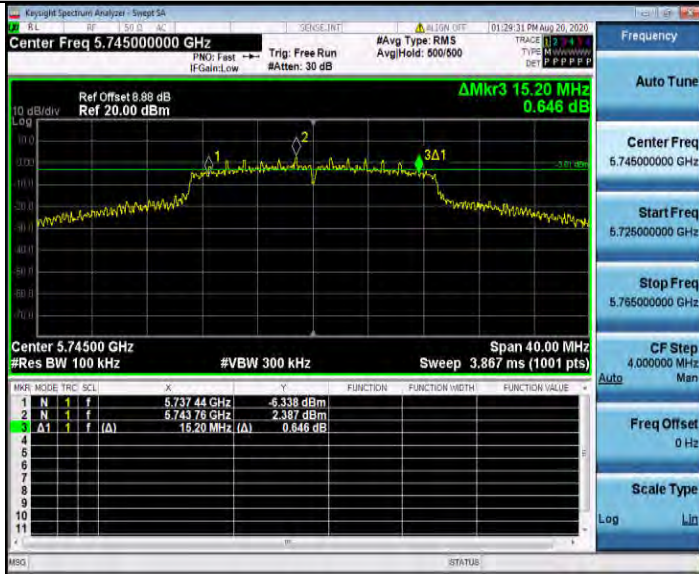

CH149

CH151

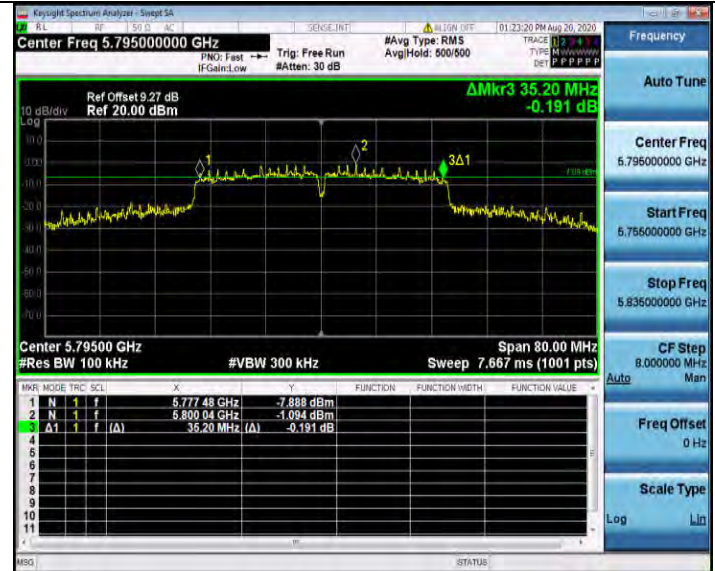
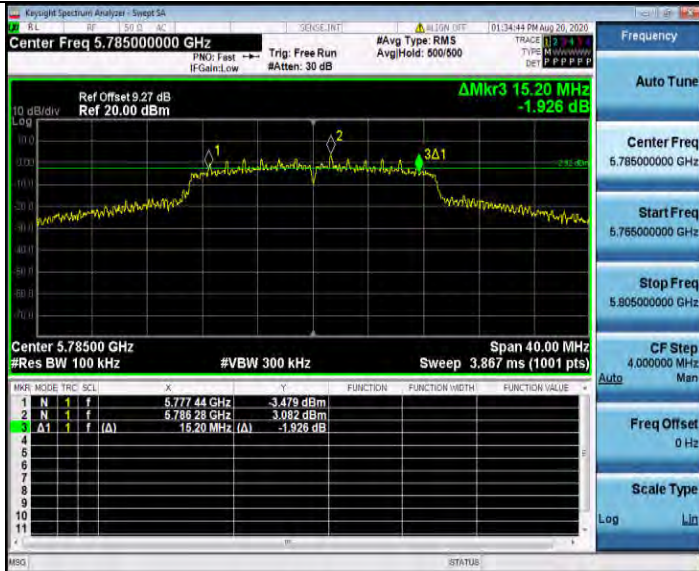

CH157

CH159



CH165

6dB Bandwidth

802.11ac40

802.11ac80

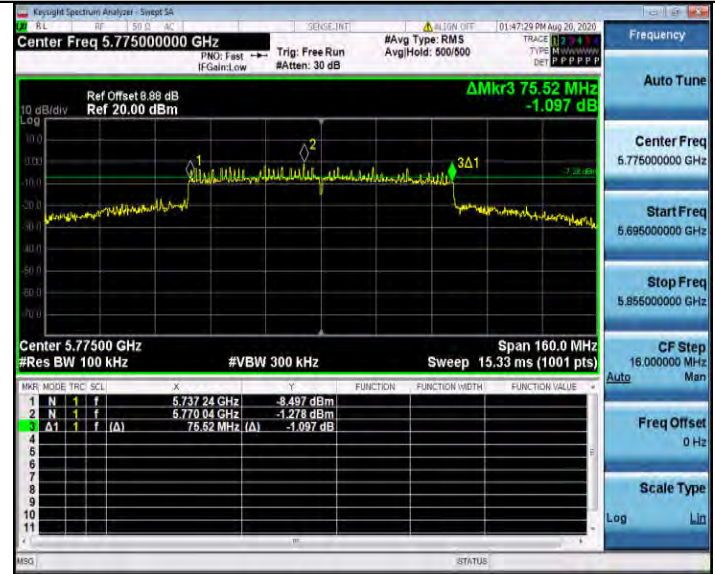
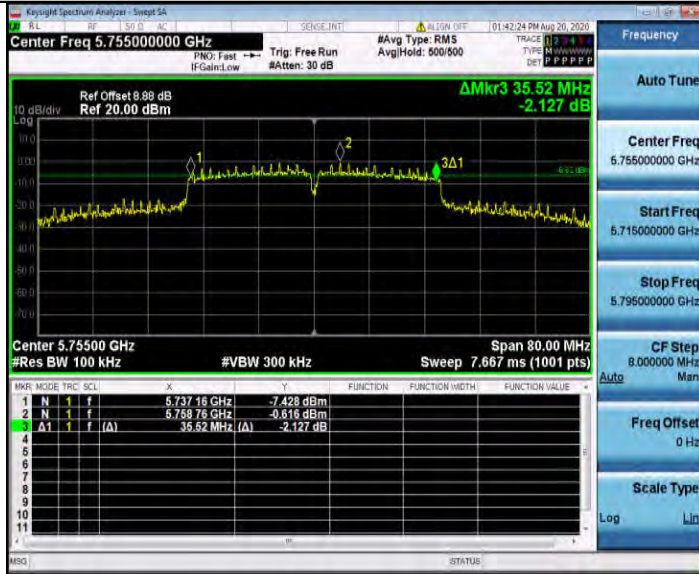

CH151

CH155

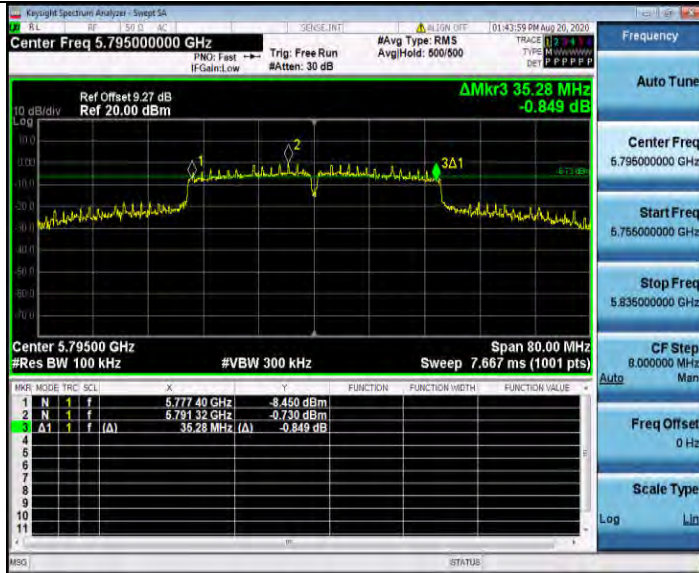

CH159

### 4.7. 26dBc Bandwidth

#### TEST CONFIGURATION

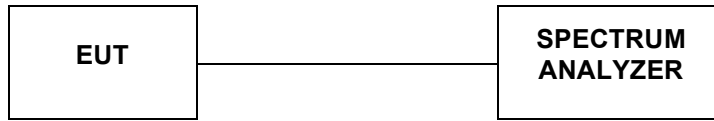

#### TEST PROCEDURE

According to KDB789033 D02 General UNII Test Procedures New Rules v01 for one of the following procedures may be used for Emission Bandwidth (EBW) measurement:

- a. Set RBW = 300 kHz (approximately 1% of the emission bandwidth).
- b. Set the video bandwidth (VBW) = 1000 KHz (VBW > RBW)
- c. Detector = Peak.
- d. Trace mode = max hold.
- e. Sweep = auto couple.
- f. Allow the trace to stabilize
- g. Measure the maximum width of the emission that is 26 dB down from the maximum of the emission. Compare this with the RBW setting of the analyzer. Readjust RBW and repeat measurement as needed until the RBW/EBW ratio is approximately 1%.

Note: The automatic bandwidth measurement capability of a spectrum analyzer or EMI receiver may be employed if it implements the functionality described above.

#### LIMIT

No Limits for 26dBc Bandwith

#### TEST RESULTS

Temperature	23.6°C	Humidity	55.7%
Test Engineer	Moon Tan	Configurations	IEEE 802.11a/n/ac

**Antenna 0:**

Type	Channel	99%Bandwidth (MHz)	26dB Bandwidth (MHz)	Limit (KHz)	Result
802.11a	36	21.872	36.360	-	Pass
	40	21.443	35.280		
	48	20.976	35.760		
802.11nHT20	36	24.524	38.480	-	Pass
	40	24.103	38.160		
	48	24.426	39.280		
802.11ac20	36	21.990	37.120	-	Pass
	40	22.505	37.600		
	48	23.527	37.720		
802.11n40	38	47.090	79.600	-	Pass
	46	47.283	80.000		
802.11ac40	38	47.810	79.440	-	Pass
	46	49.929	78.560		
802.11ac80	42	92.239	159.840	-	Pass

**Antenna 1:**

Type	Channel	99%Bandwidth (MHz)	26dB Bandwidth (MHz)	Limit (KHz)	Result
802.11a	36	22.444	36.480	-	Pass
	40	22.879	37.400		
	48	23.536	36.800		
802.11nHT20	36	25.566	39.480	-	Pass
	40	26.246	39.720		
	48	27.122	39.840		
802.11ac20	36	23.161	37.600	-	Pass
	40	23.553	38.480		
	48	24.072	38.680		
802.11n40	38	50.760	79.840	-	Pass
	46	53.198	80.000		
802.11ac40	38	48.440	79.840	-	Pass
	46	50.937	79.760		
802.11ac80	42	119.64	160.000	-	Pass



Antenna 0:

99%Bandwidth

802.11a

802.11n HT20



CH36

CH36



CH40

CH40



CH48

CH48

99%Bandwidth

802.11ac20

802.11n HT40



CH36

CH38



CH40

CH46



CH48

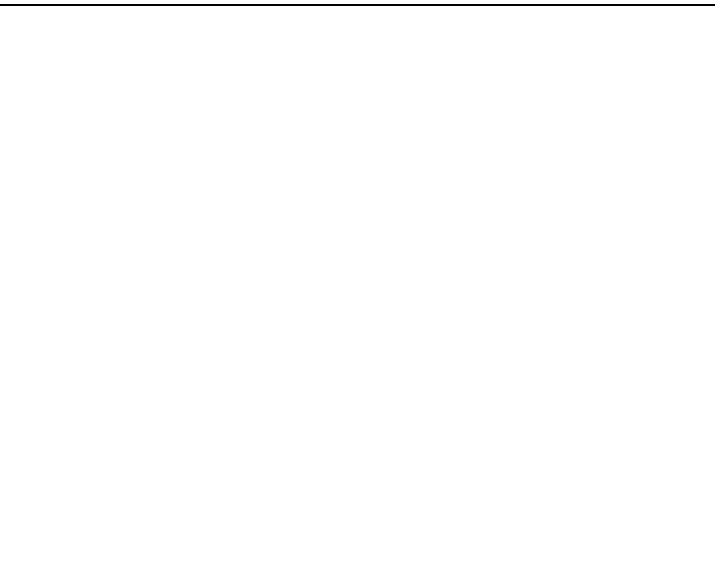



99%Bandwidth

802.11ac40

802.11ac80



CH38

CH42



CH46



26dB Bandwidth

802.11a

802.11n HT20



CH36

CH36



CH40

CH40



CH48

CH48

26dB Bandwidth

802.11ac20

802.11n HT40



CH36

CH38



CH40

CH46



CH48



26dB Bandwidth

802.11ac40

802.11ac80



CH38

CH42



CH46

Antenna 1:





99%Bandwidth

802.11ac20

802.11n HT40



CH36

CH38



CH40

CH46



CH48

99%Bandwidth

802.11ac40

802.11ac80



CH38

CH42



CH46





26dB Bandwidth

802.11a

802.11n HT20



CH36

CH36



CH40

CH40



CH48

CH48



26dB Bandwidth

802.11ac20

802.11n HT40

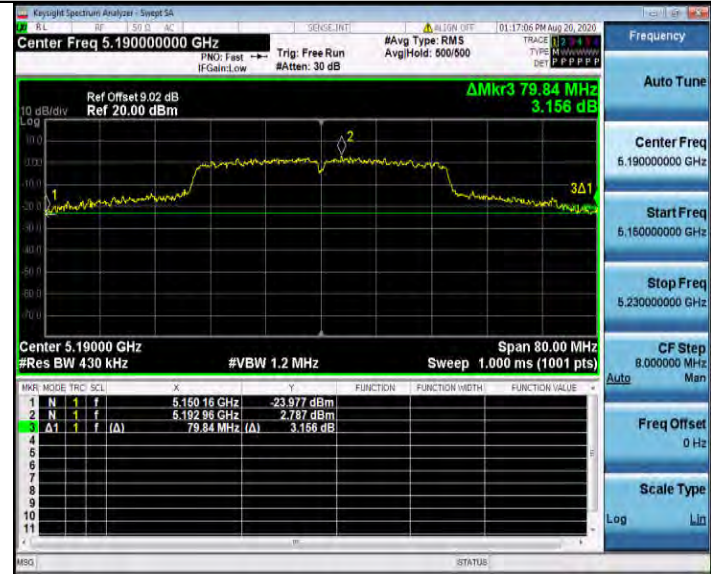

CH36

CH38



CH40

CH46



CH48



26dB Bandwidth

802.11ac40

802.11ac80

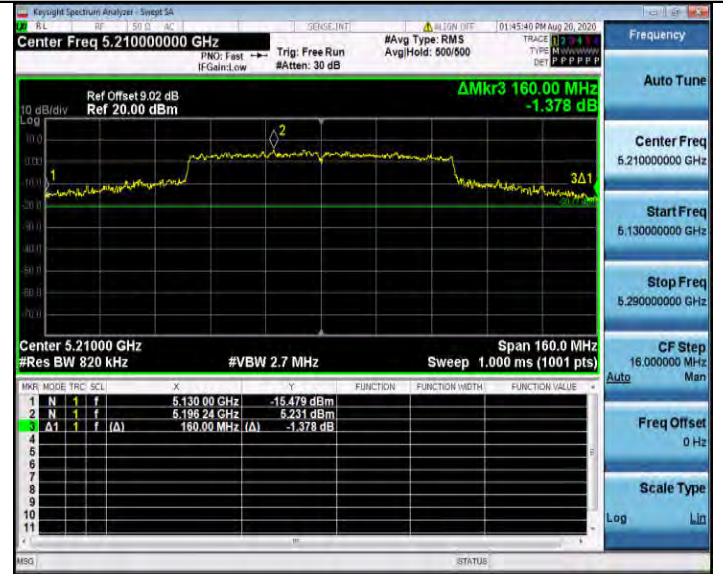

CH38

CH42



CH46

### 4.8. Band Edge Compliance

#### TEST CONFIGURATION

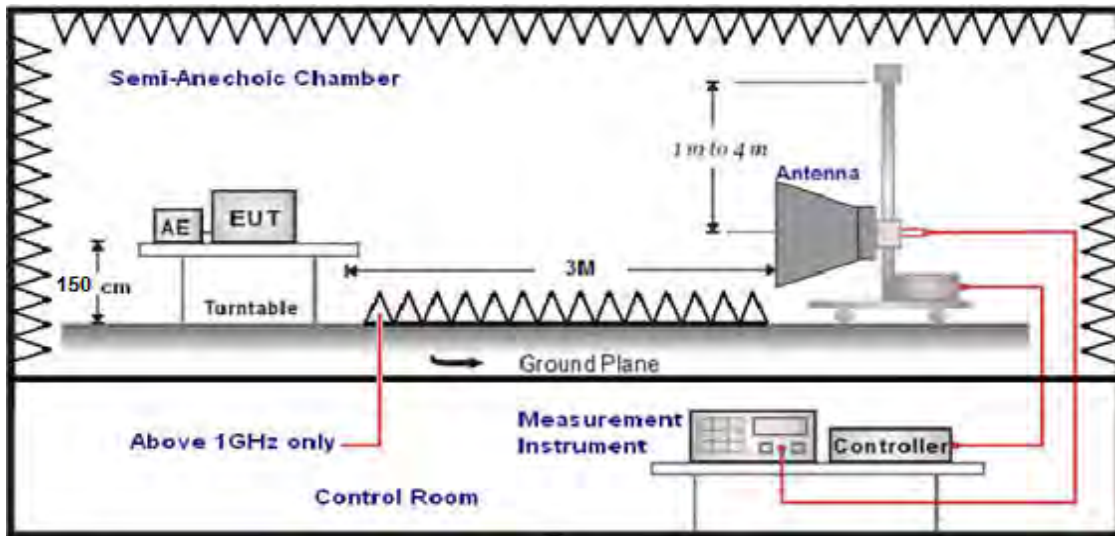

#### LIMIT

20dBc in any 100 kHz bandwidth outside the operating frequency band. In case the emission fall within the restricted band specified on 15.205(a), then the 15.209(a) limit in the table below has to be followed.

Frequency (MHz)	Distance (Meters)	Radiated (dBµV/m)	Radiated (µV/m)
0.009-0.49	3	$20\log(2400/F(KHz))+40\log(300/3)$	$2400/F(KHz)$
0.49-1.705	3	$20\log(24000/F(KHz))+40\log(30/3)$	$24000/F(KHz)$
1.705-30	3	$20\log(30)+40\log(30/3)$	30
30-88	3	40.0	100
88-216	3	43.5	150
216-960	3	46.0	200
Above 960	3	54.0	500

According to §15.407 (b): Except as shown in paragraph (b)(7) of this section, the maximum emissions outside of the frequency bands of operation shall be attenuated in accordance with the following limits

Frequency (MHz)	EIRP Limit (dBm)	Equivalent Field Strength at 3m (dBµV/m)
5150-5250	-27	68.2
5250-5350	-27	68.2
5470-5725	-27	68.2
5725-5850	-27 (beyond 10MHz of the bandedge)	68.2
	-17 (within 10 MHz of band edge)	78.2

#### TEST PROCEDURE

1. The EUT was placed on a turn table which is 1.5m above 1GHz.
2. Maximum procedure was performed by raising the receiving antenna from 1m to 4m and rotating the turn table from 0° to 360° to acquire the highest emissions from EUT.
3. And also, each emission was to be maximized by changing the polarization of receiving antenna both horizontal and vertical.
4. Repeat above procedures until all frequency measurements have been completed..
5. The distance between test antenna and EUT as following table states:

Test Frequency range	Test Antenna Type	Test Distance
1GHz-18GHz	Double Ridged Horn Antenna	3



6. Setting test receiver/spectrum as following table states:

Test Frequency range	Test Receiver/Spectrum Setting	Detector
1GHz-18GHz	Peak Value: RBW=1MHz/VBW=3MHz, Sweep time=Auto Average Value: RBW=1MHz/VBW=10Hz, Sweep time=Auto	Peak

**Field Strength Calculation**

The field strength is calculated by adding the Antenna Factor and Cable Factor and subtracting the Amplifier Gain and Duty Cycle Correction Factor(if any) from the measured reading. The basic equation with a sample calculation is as follows:

**FS = RA + AF + CL - AG**

Where FS = Field Strength	CL = Cable Attenuation Factor (Cable Loss)
RA = Reading Amplitude	AG = Amplifier Gain
AF = Antenna Factor	

**TEST RESULTS**

Remark:For radiated bandedge We measured at both mode, recorded worst case in antenna 0's 802.11 ac20 mode;

## For Radiated Bandedge Measurement

Temperature	23.4°C	Humidity	54.5%
Test Engineer	Moon Tan	Configurations	IEEE 802.11a/n/ac

**NOTE: We measured Radiated Emission at Antenna 0 & Antenna 1 mode from 1GHz to 25GHz and the worst case was recorded(Antenna 0).**

**802.11 ac20/ Channel 36 :5180 MHz**

Freq (MHz)	Read Level (dBμV)	Antenna Factor (dB/m)	PRM Factor (dB)	Cable Loss (dB)	Result Level (dBμV/m)	Limit Line (dBμV/m)	Margin (dB)	Detector	Polarization
4500.0	35.09	35.58	29.04	8.28	49.91	68.20	-18.29	Peak	Horizontal
4500.0	30.05	35.58	29.04	8.28	44.87	54.00	-9.13	AV	Horizontal
5150.0	39.15	35.58	29.04	8.28	53.97	68.20	-14.23	Peak	Horizontal
5150.0	30.56	35.58	29.04	8.28	45.38	54.00	-8.62	AV	Horizontal

**802.11 ac20/ Channel 48 :5240 MHz**

Freq (MHz)	Read Level (dBμV)	Antenna Factor (dB/m)	PRM Factor (dB)	Cable Loss (dB)	Result Level (dBμV/m)	Limit Line (dBμV/m)	Margin (dB)	Detector	Polarization
5350.0	35.28	35.42	29.06	8.39	50.03	68.20	-18.17	Peak	Horizontal
5350.0	30.30	35.42	29.06	8.39	45.05	54.00	-8.95	AV	Horizontal
5460.0	39.11	35.42	29.06	8.39	53.86	68.20	-14.34	Peak	Horizontal
5460.0	30.69	35.42	29.06	8.39	45.44	54.00	-8.56	AV	Horizontal

**802.11 ac20/ Channel 149 :5745 MHz**

Freq (MHz)	Read Level (dBμV)	Antenna Factor (dB/m)	PRM Factor (dB)	Cable Loss (dB)	Result Level (dBμV/m)	Limit Line (dBμV/m)	Margin (dB)	Detector	Polarization
5650.0	30.10	35.35	29.07	8.43	44.81	68.20	-23.39	Peak	Horizontal
5700.0	30.27	35.35	29.07	8.43	44.98	68.20	-23.22	Peak	Horizontal
5720.0	32.18	35.35	29.07	8.43	46.89	68.20	-21.31	Peak	Horizontal
5725.0	30.67	35.35	29.07	8.43	45.38	68.20	-22.82	Peak	Horizontal

**802.11 ac20/ Channel 165 :5825 MHz**

Freq (MHz)	Read Level (dBμV)	Antenna Factor (dB/m)	PRM Factor (dB)	Cable Loss (dB)	Result Level (dBμV/m)	Limit Line (dBμV/m)	Margin (dB)	Detector	Polarization
5850.0	30.05	35.3	29.11	8.51	44.75	68.20	-23.45	Peak	Horizontal
5855.0	30.38	35.3	29.11	8.51	45.08	68.20	-23.12	Peak	Horizontal
5875.0	32.02	35.3	29.11	8.51	46.72	68.20	-21.48	Peak	Horizontal
5925.0	30.67	35.3	29.11	8.51	45.37	68.20	-22.83	Peak	Horizontal

## REMARKS:

1. Result Level = Read Level + Antenna Factor + Cable loss - PRM Factor.
2. Margin value = Result Level-Limit value.
2. The other emission levels were very low against the limit.
3. The average measurement was not performed when the peak measured data under the limit of average detection.
4. Detector AV is setting spectrum/receiver. RBW=1MHz/VBW=10Hz/Sweep time=Auto/Detector=Peak;



For Conducted Band edge Measurement

Temperature	23.6°C	Humidity	55.7%
Test Engineer	Moon Tan	Configurations	IEEE 802.11a/n/ac

The test results have included the antenna gain

Antenna 0:  
5150-5250MHz:

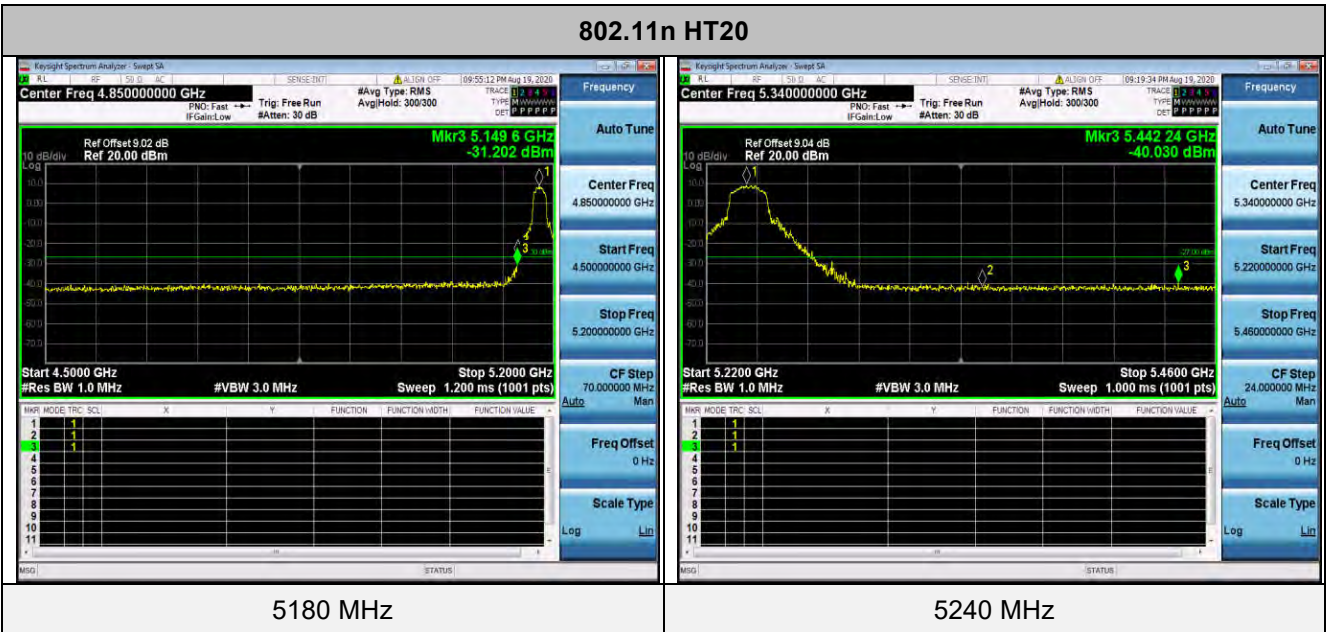
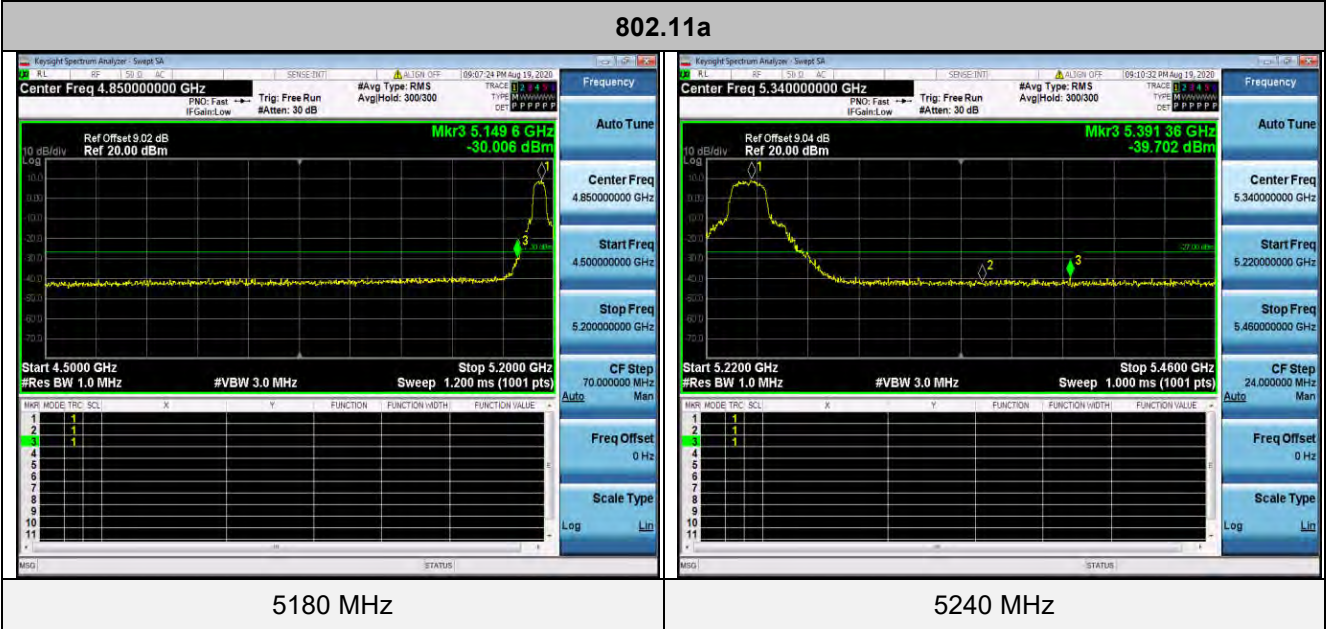

802.11ac20

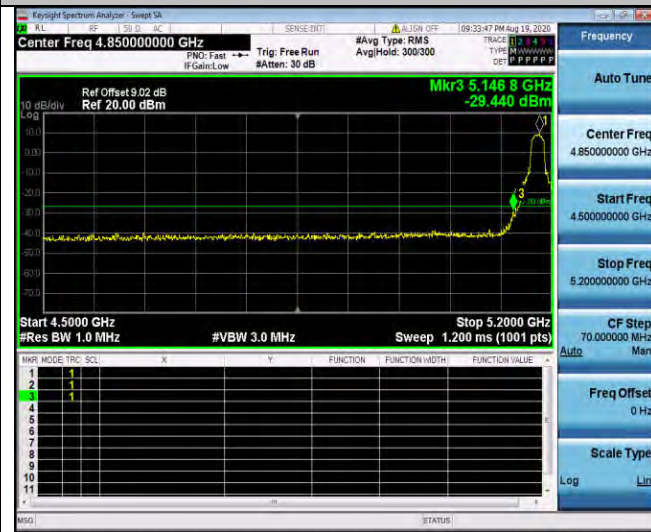

5180 MHz



5240 MHz

802.11n HT40

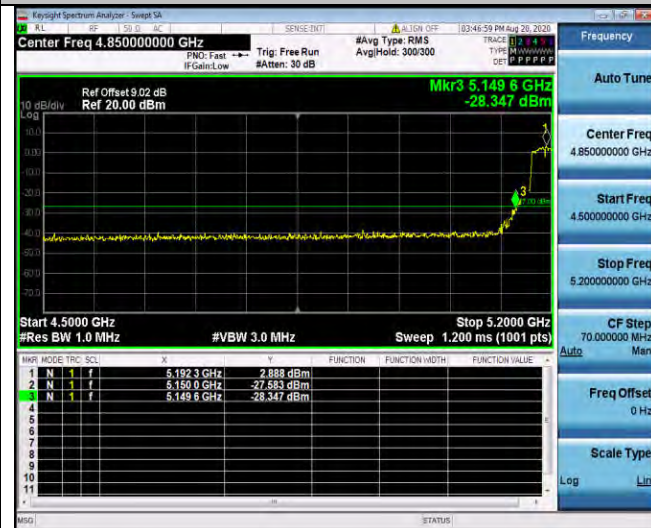

5190 MHz



5230 MHz



802.11ac40

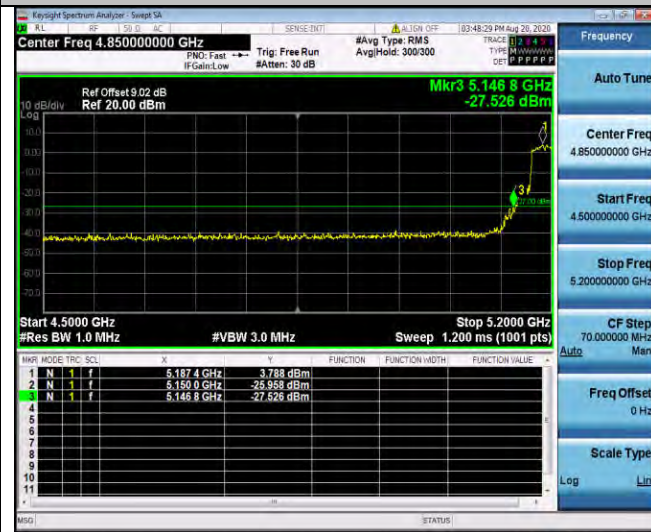

5190 MHz



5230 MHz

802.11ac80



5210 MHz



5210 MHz

5725-5850MHz:

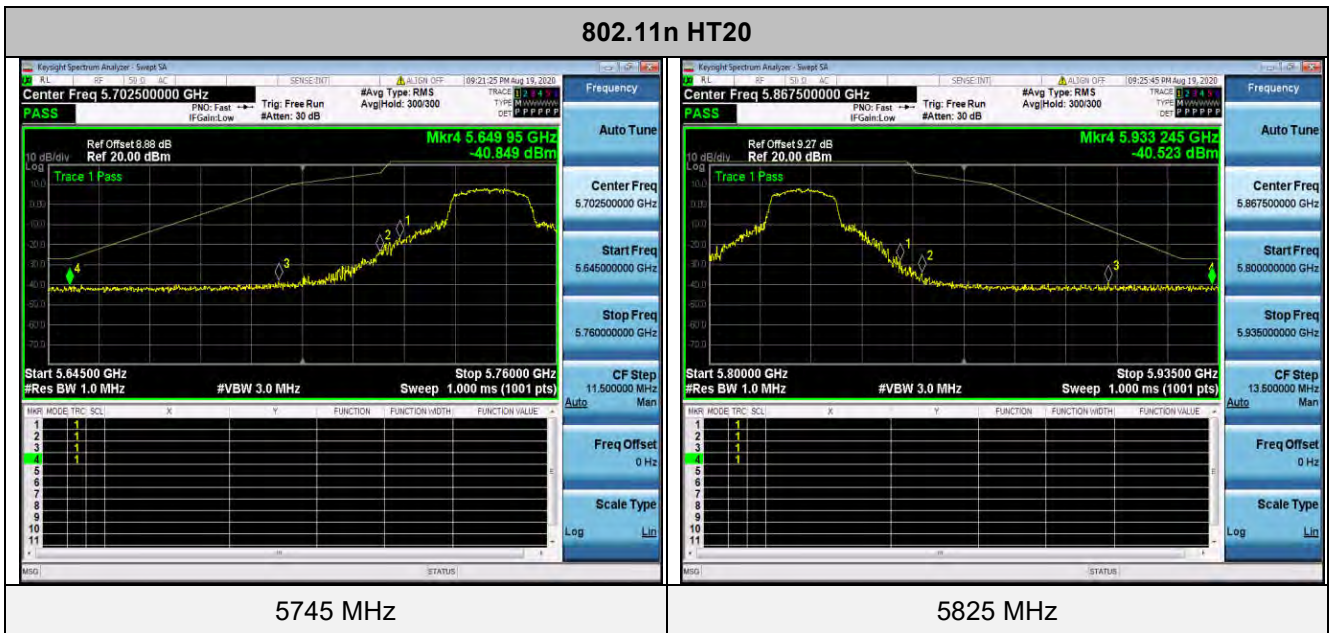
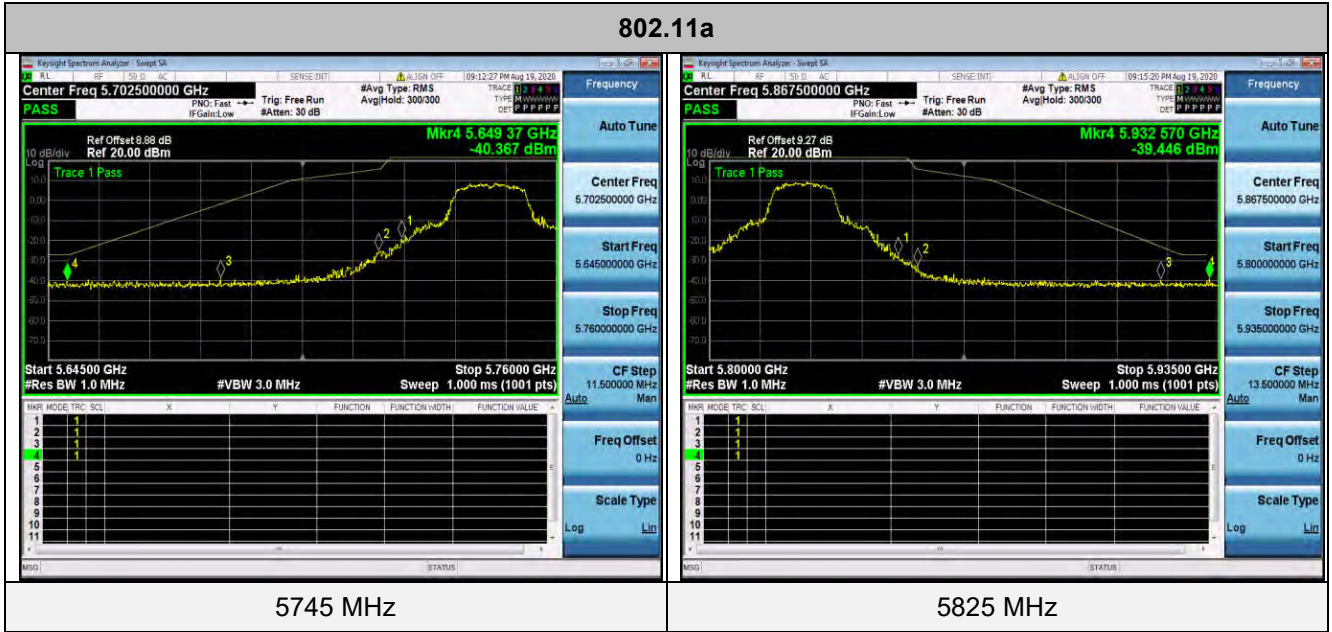



802.11ac20



5745 MHz



5825 MHz

802.11n HT40



5755 MHz



5795 MHz



802.11ac40



5755 MHz



5795 MHz

802.11ac80



5775 MHz



5775 MHz

Antenna 1:  
5150-5250MHz:

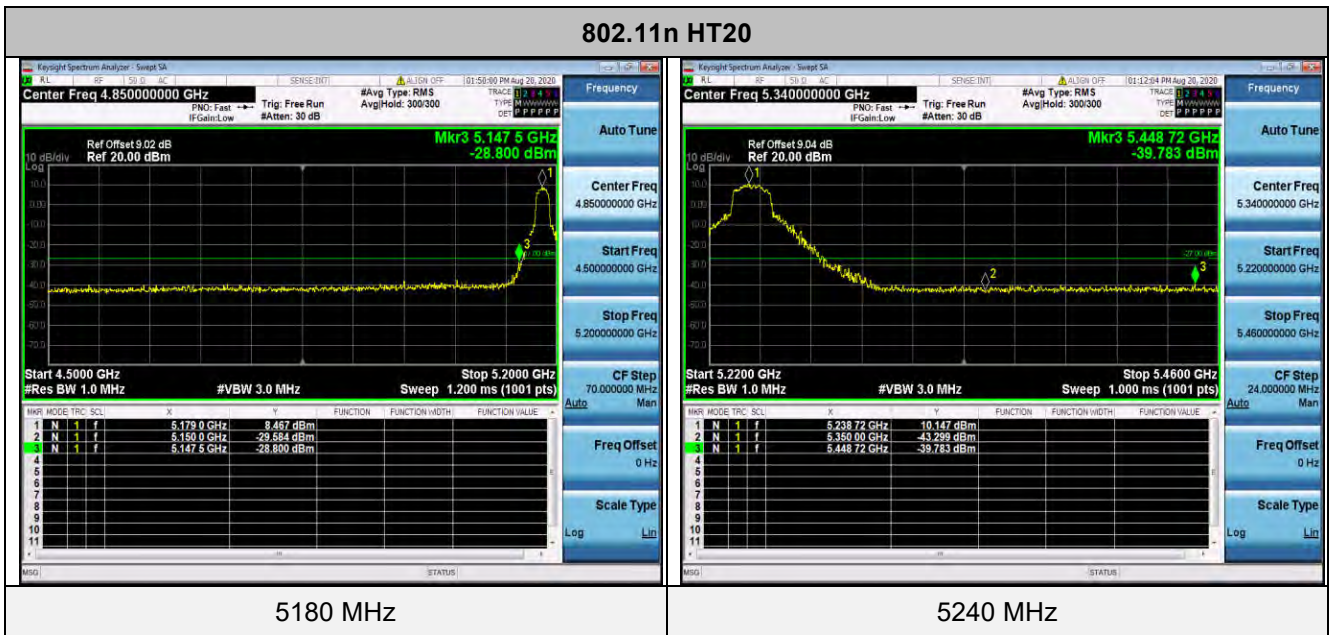
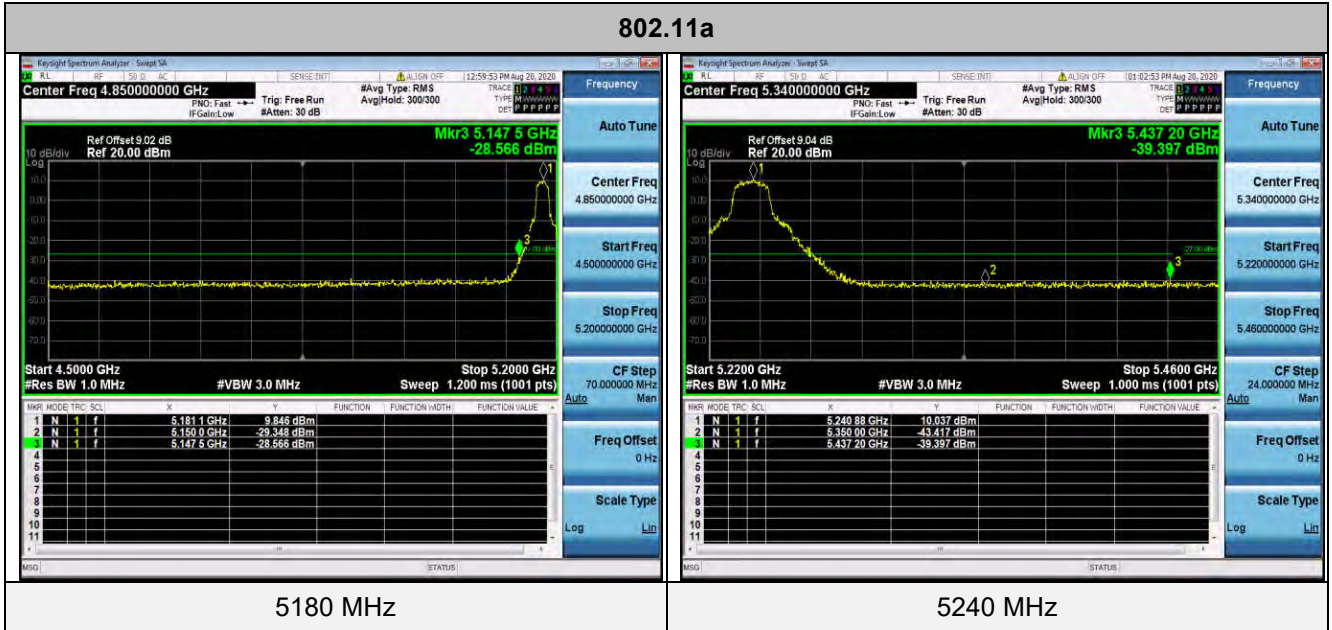



802.11ac20

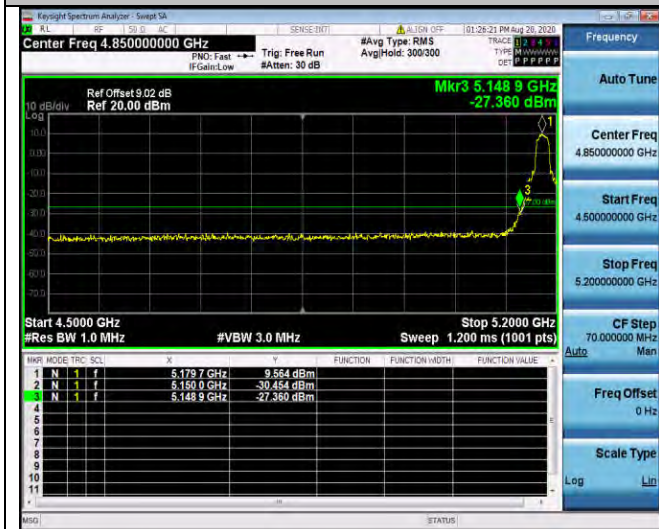

5180 MHz



5240 MHz

802.11n HT40

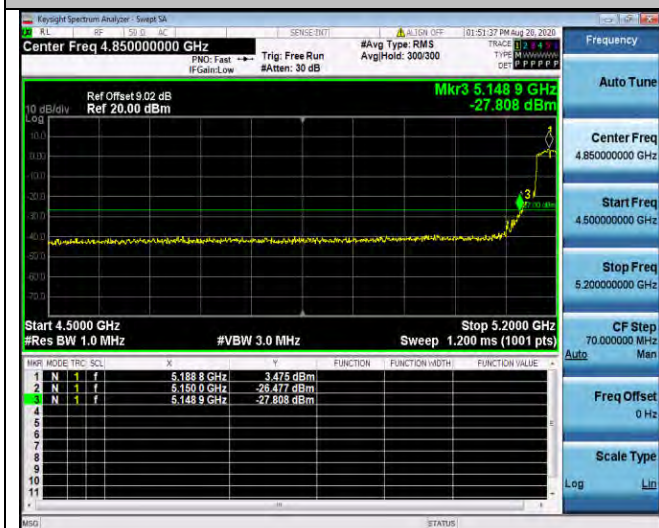

5190 MHz



5230 MHz

802.11ac40



5190 MHz



5230 MHz

802.11ac80



5210 MHz



5210 MHz



5725-5850MHz:

802.11a



5745 MHz



5825 MHz

802.11n HT20



5745 MHz



5825 MHz

802.11ac20



5745 MHz



5825 MHz

802.11n HT40



5755 MHz



5795 MHz



802.11ac40



5755 MHz



5795 MHz

802.11ac80



5775 MHz



5775 MHz

## 4.9. Frequency Stability

### Standard Applicable

According to FCC §15.407(g) “Manufacturers of U-NII devices are responsible for ensuring frequency stability such that an emission is maintained within the band of operation under all conditions of normal operation as specified in the user manual.”

According to FCC §2.1055(a) “The frequency stability shall be measured with variation of ambient temperature as follows:”

(1) From -30° to + 50° centigrade for all equipment except that specified in paragraphs (a) (2) and (3) of this section.

(2) From -20° to + 50° centigrade for equipment to be licensed for use in the Maritime Services under part 80 of this chapter, except for Class A, B, and S Emergency Position Indicating Radiobeacons (EPIRBS), and equipment to be licensed for use above 952 MHz at operational fixed stations in all services, stations in the Local Television Transmission Service and Point-to-Point Microwave Radio Service under part 21 of this chapter, equipment licensed for use aboard aircraft in the Aviation Services under part 87 of this chapter, and equipment authorized for use in the Family Radio Service under part 95 of this chapter.

(3) From 0° to + 50° centigrade for equipment to be licensed for use in the Radio Broadcast Services under part 73 of this chapter.

### Test Configuration

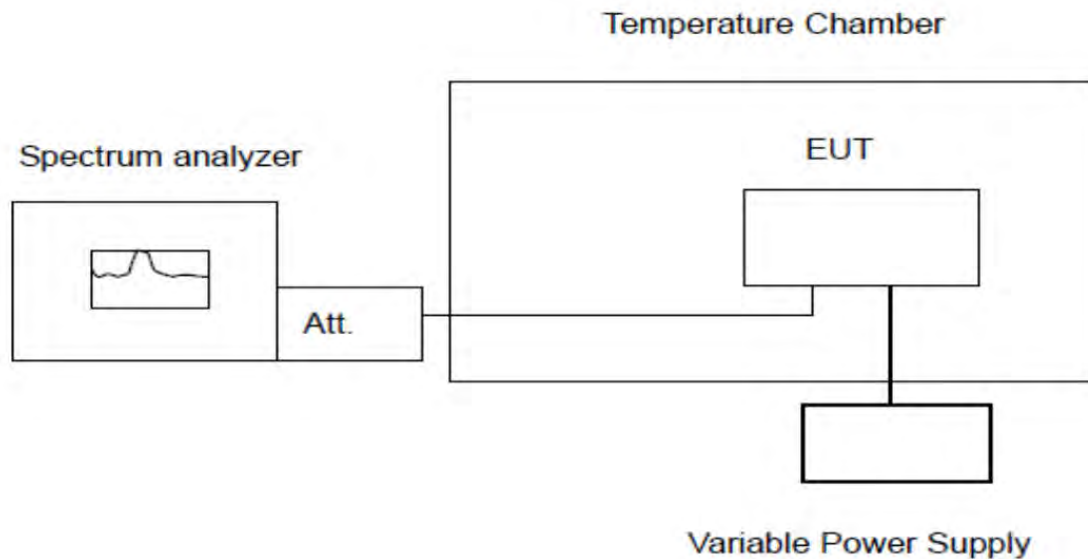

### Test Procedure

The equipment under test was connected to an external AC or DC power supply and input rated voltage. RF output was connected to a frequency counter or spectrum analyzer via feed through attenuators. The EUT was placed inside the temperature chamber. Set the spectrum analyzer RBW low enough to obtain the desired frequency resolution and measure EUT 20 degree operating frequency as reference frequency. Turn EUT off and set the chamber temperature to -30 degree. After the temperature stabilized for approximately 30 minutes recorded the frequency. Repeat step measure with 10 degree increased per stage until the highest temperature of +50 degree reached.

### Test Results

PASS



Remark:

1. Measured all conditions and recorded worst case.

IEEE 802.11a Mode / 5180 – 5240 MHz / 5180 MHz

Environment Temperature (Degree)	Voltage (V)	Measured Frequency (MHz)	Limit Range (MHz)	Test Results
20	DC 5.5V	5180.121	5150 – 5250	PASS
20	DC 4.5V	5180.138	5150 – 5250	PASS
50	DC 5V	5180.167	5150 – 5250	PASS
40	DC 5V	5180.123	5150 – 5250	PASS
30	DC 5V	5180.126	5150 – 5250	PASS
20	DC 5V	5180.146	5150 – 5250	PASS
10	DC 5V	5180.138	5150 – 5250	PASS
0	DC 5V	5180.119	5150 – 5250	PASS
-10	DC 5V	5180.125	5150 – 5250	PASS
-20	DC 5V	5180.139	5150 – 5250	PASS
-30	DC 5V	5180.115	5150 – 5250	PASS

IEEE 802.11a Mode / 5180 – 5240 MHz / 5240 MHz

Environment Temperature (Degree)	Voltage (V)	Measured Frequency (MHz)	Limit Range (MHz)	Test Results
20	DC 5.5V	5240.131	5150 – 5250	PASS
20	DC 4.5V	5240.125	5150 – 5250	PASS
50	DC 5V	5240.128	5150 – 5250	PASS
40	DC 5V	5240.111	5150 – 5250	PASS
30	DC 5V	5240.162	5150 – 5250	PASS
20	DC 5V	5240.133	5150 – 5250	PASS
10	DC 5V	5240.115	5150 – 5250	PASS
0	DC 5V	5240.185	5150 – 5250	PASS
-10	DC 5V	5240.112	5150 – 5250	PASS
-20	DC 5V	5240.141	5150 – 5250	PASS
-30	DC 5V	5240.128	5150 – 5250	PASS

IEEE 802.11a Mode / 5745 – 5825 MHz / 5745 MHz

Environment Temperature (Degree)	Voltage (V)	Measured Frequency (MHz)	Limit Range (MHz)	Test Results
20	DC 5.5V	5475.127	5725 – 5850	PASS
20	DC 4.5V	5475.112	5725 – 5850	PASS
50	DC 5V	5475.138	5725 – 5850	PASS
40	DC 5V	5475.144	5725 – 5850	PASS
30	DC 5V	5475.148	5725 – 5850	PASS
20	DC 5V	5475.139	5725 – 5850	PASS
10	DC 5V	5475.177	5725 – 5850	PASS
0	DC 5V	5475.122	5725 – 5850	PASS
-10	DC 5V	5475.147	5725 – 5850	PASS
-20	DC 5V	5475.136	5725 – 5850	PASS
-30	DC 5V	5475.142	5725 – 5850	PASS

IEEE 802.11a Mode / 5745 – 5825 MHz / 5825 MHz

Environment Temperature (Degree)	Voltage (V)	Measured Frequency (MHz)	Limit Range (MHz)	Test Results
20	DC 5.5V	5825.155	5725 – 5850	PASS
20	DC 4.5V	5825.136	5725 – 5850	PASS
50	DC 5V	5825.125	5725 – 5850	PASS
40	DC 5V	5825.169	5725 – 5850	PASS
30	DC 5V	5825.151	5725 – 5850	PASS
20	DC 5V	5825.132	5725 – 5850	PASS
10	DC 5V	5825.143	5725 – 5850	PASS
0	DC 5V	5825.142	5725 – 5850	PASS
-10	DC 5V	5825.159	5725 – 5850	PASS
-20	DC 5V	5825.141	5725 – 5850	PASS
-30	DC 5V	5825.139	5725 – 5850	PASS



## 4.10. Antenna Requirement

### Standard Applicable

For intentional device, according to FCC 47 CFR Section 15.203, an intentional radiator shall be designed to ensure that no antenna other than that furnished by the responsible party shall be used with the device.

And according to FCC 47 CFR Section 15.407 (a), if transmitting antennas of directional gain greater than 6dBi are used, the power shall be reduced by the amount in dB that the directional gain of the antenna exceeds 6dBi.

### **Antenna Information**

The antenna is FPC antenna, through the buckle stretched out, The directional gains of antenna used for transmitting is 2dBi.

Reference to the Test Report: **GTS20200812009-1-15.**

**5. TEST SETUP PHOTOS OF THE EUT**

Reference to the test report No. GTS20200812009-1-15.

**6. EXTERNAL AND INTERNAL PHOTOS OF THE EUT**

Reference to the test report No. GTS20200812009-1-15.

.....**End of Report**.....