



Product Specification

Reversion	v1.0		
Date	2017-03-14		
Model Name	BL-M7603NU4		
Product Name	IEEE 802.11b/g/n (2T2R) WLAN USB Module		
Blink Approve Field			
ENGINEER	QC	SALES	
Customer Approve Field			
ENGINEER	QC	MANUFACTORY	PURCHASING

联系人：邓海兵

MO:13662644686

Content

Content	1
1. General Description.....	2
2. Applications	2
3. Product Specification.....	2
3.1 Function Block diagram.....	2
3.2 Electrical and Performance Specification	2
3.3 DC Characteristic.....	3
3.4 RF Characteristic	4
3.5 Product Photo	5
3.6 Mechanical Specification	5
3.7 ProductPinDefinition.....	6
4. Supported platform.....	7
5. Typical Application Circuit.....	8
6. Package information	9
7. Typical Solder Reflow Profile	9
8. Precautions for use	10

1. General Description

BL-M7603NU4 is a highly integrated Wi-Fi single chip which support 300 Mbps PHY rate. It fully complies with IEEE802.11n and IEEE802.11b/g standard, offering feature-rich wireless connectivity at high standard, and delivering reliable, cost-effective throughput from an extended distance.

Optimized RF architecture and baseband algorithms provide superb performance and lower power consumption. Intelligent MAC design deploys a high efficient DMA engine and hardware data processing accelerators which offloads the host processor.

2. Applications

MID, networking camera, STB GPS, E-book, Hard disk player, Network Radios, PSP and other device which need be supported by wireless networking.

3. Product Specification

3.1 Function Block diagram

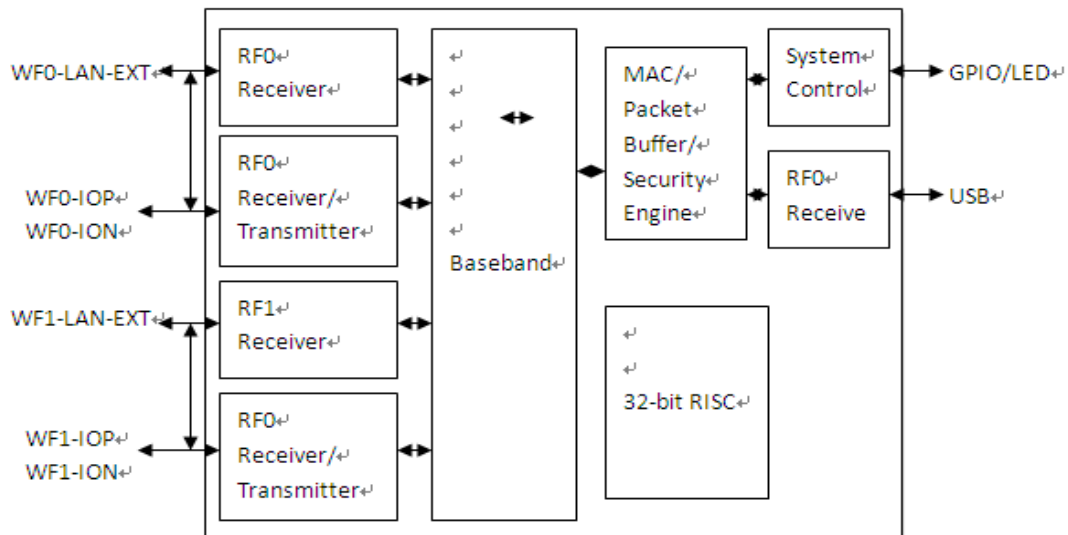

Figure 1 MT7603U block diagram

3.2 Electrical and Performance Specification

Item	Description
Product Name	BL-M7603NU4
Major Chipset	MT7603U

Host Interface	USB2.0
Standard	IEEE 802.11b, IEEE 802.11g, IEEE 802.11n
Frequency Range	2.4GHz~2.4835GHz
Modulation Type	802.11b: CCK, DQPSK, DBPSK 802.11g: 64-QAM, 16-QAM, QPSK, BPSK 802.11n: 64-QAM, 16-QAM, QPSK, BPSK
Working Mode	Infrastructure, Ad-Hoc
Data Transfer Rate	1, 2, 5.5, 6, 11, 12, 18, 22, 24, 30, 36, 48, 54, 135, 300 Mbps (self-adapting)
Spread Spectrum	IEEE 802.11b: DSSS (Direct Sequence Spread Spectrum) IEEE 802.11g/n: OFDM (Orthogonal Frequency Division Multiplexing)
Sensitivity @PER	1M: -94dBm@8%PER 9M: -90dBm@10%PER 11M: -88dBm@8%PER 54M: -74dBm@10%PER 135M: -68dBm@10%PER
RF Power	14.71dBm@11b, 14.68dBm@11g, 14.93dBm@11n
Antenna type	Connect to the external antenna through the IPEX connector
The transmit distance	Indoor 100M, Outdoor 300M, according to the local environment
Dimension(L*W*H)	27x 17.7x 2.0mm (LxWxH)
Power supply	3.3V +/-0.2V
Power Consumption	standby mode 65mA@3.3V, Working mode 245mA@3.3V
Clock source	40MHz
Working Temperature	-10°C to +50°C
Storage temperature	-40°C to +70°C

3.3 DC Characteristic

Terms	Contents			
Specification : IEEE802.11b				
Mode	DSSS / CCK			
Frequency	2412 – 2484MHz			
Data rate	1, 2, 5.5, 11Mbps			
DC Characteristics	min	Typ	max	unit
TX mode	480	650	750	mA
Rx mode	91	100	105	mA
Sleep mode	58	60	65	mA
Specification : IEEE802.11g				
Mode	OFDM			

Frequency	2412 - 2484MHz			
Data rate	6, 9, 12, 18, 24, 36, 48, 54Mbps			
DC Characteristics	min	Typ	max	unit
TX mode	170	230	480	mA
Rx mode	95	105	109	mA
Sleep mode	58	60	65	mA
Specification : IEEE802.11n				
Mode	OFDM			
Frequency	2412 - 2484MHz			
Data rate	6.5, 13, 19.5, 26, 39, 135,300Mbps			
DC Characteristics	min	Typ	max	unit
TX mode	165	220	450	mA
Rx mode	95	105	110	mA
Sleep mode	58	60	65	mA

3.4 Product Photo

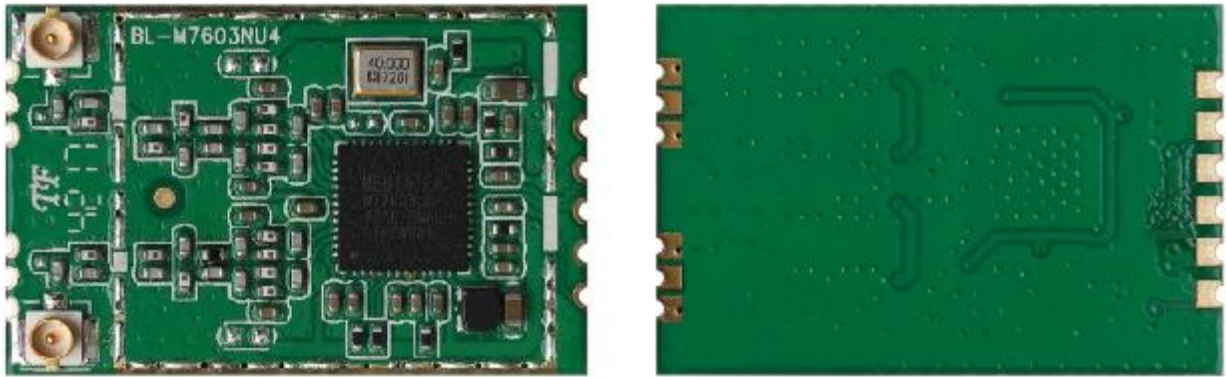

3.5 Mechanical Specification

Module dimension: Typical (W x L x H): 27.0mmx17.7mmx2.0mm Tolerance : +/-0.2mm

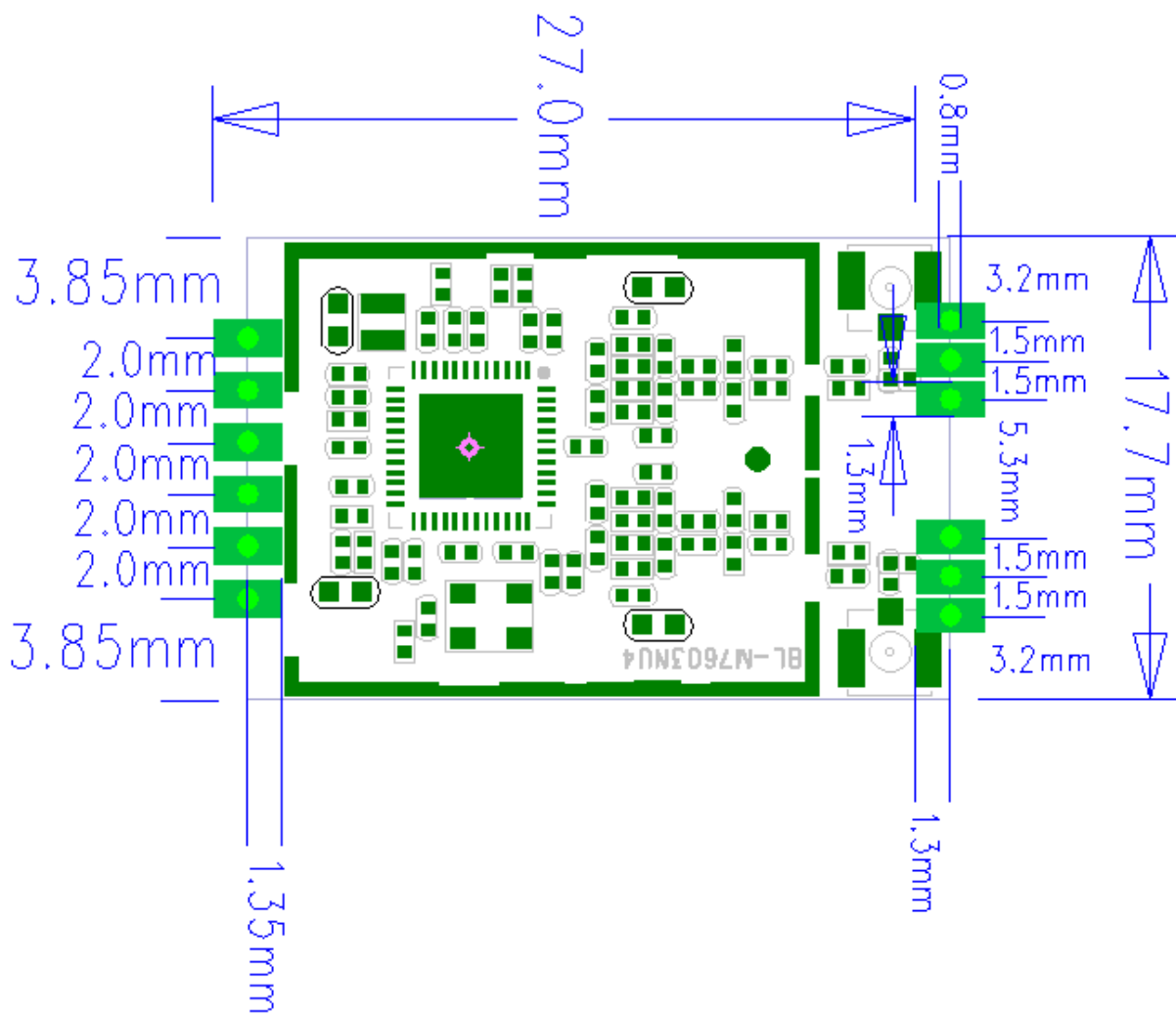

3.6 Product Pin Definition

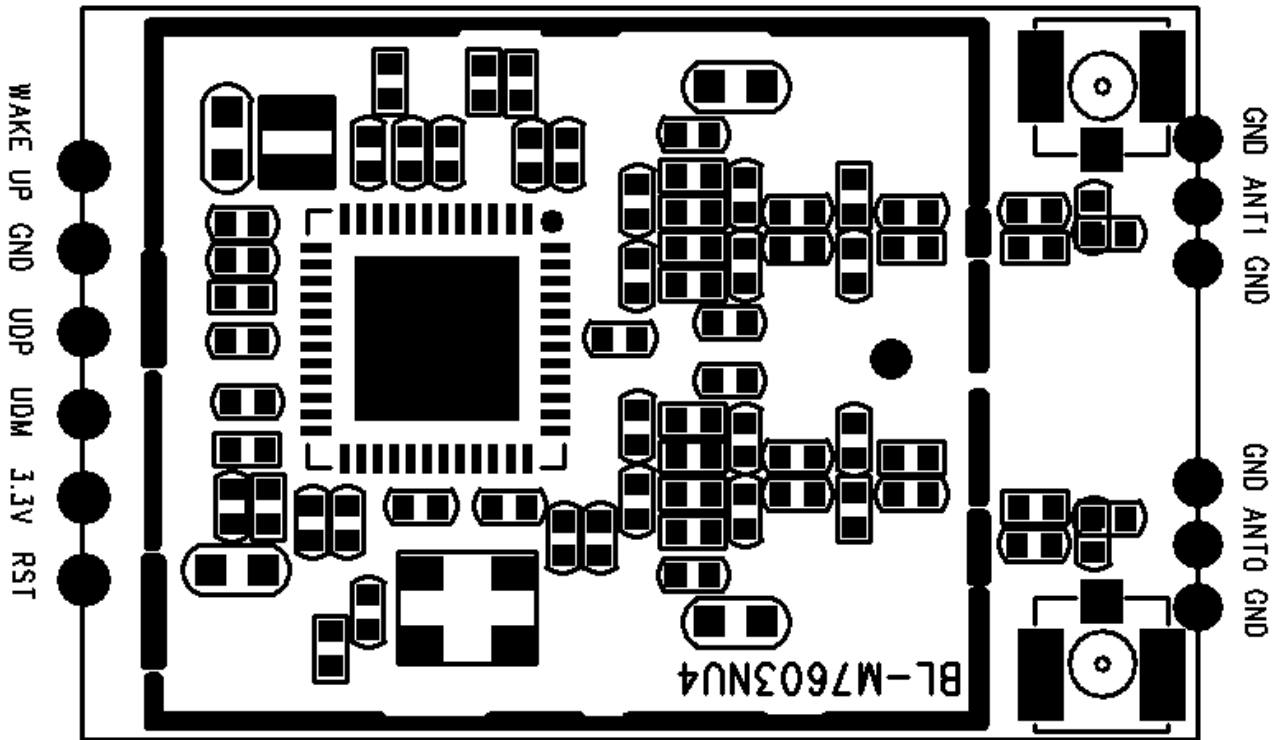

NO	Name	Description
1	WOW	Wake up
2	GND	Ground connected
3	UDP	USB positive differential data lines
4	UDM	USB negative differential data lines
5	3.3V	Power supply 3.3V is required
6	RST_N	Reset
7	GND	Ground connected
8	RF0	WIFI -Ant0
9	GND	Ground connected
10	GND	Ground connected
11	RF1	WIFI -Ant1
12	GND	Ground connected

4. Supported platform

Operating System	CPU Framework	Driver
WIN2000/XP/VISTA/WIN7	X86 Platform	Enable
LINUX2.4/2.6	ARM, MIPSII	Enable
WINCE5.0/6.0	ARM ,MIPSII	Enable

5. Typical Application Circuit

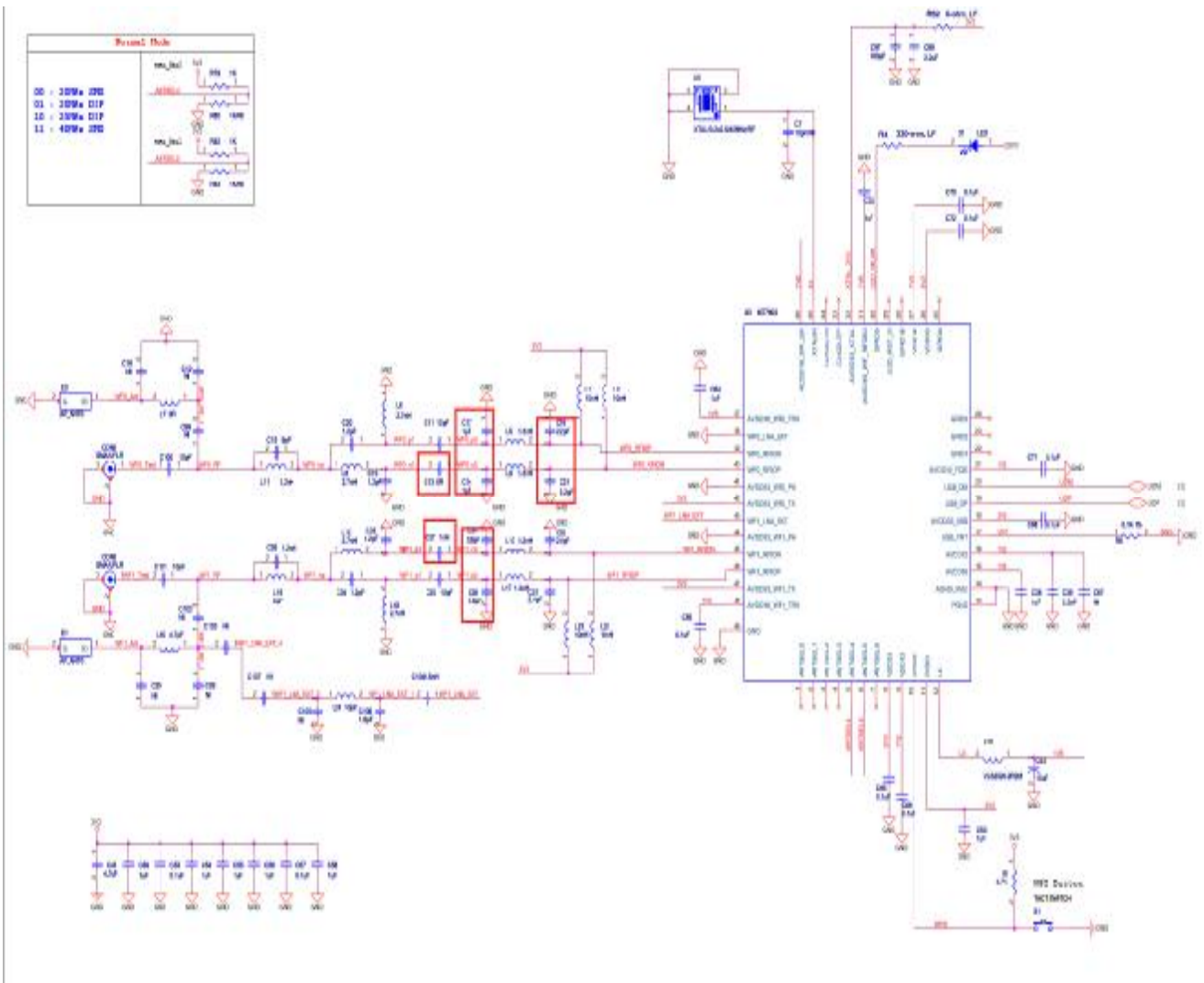

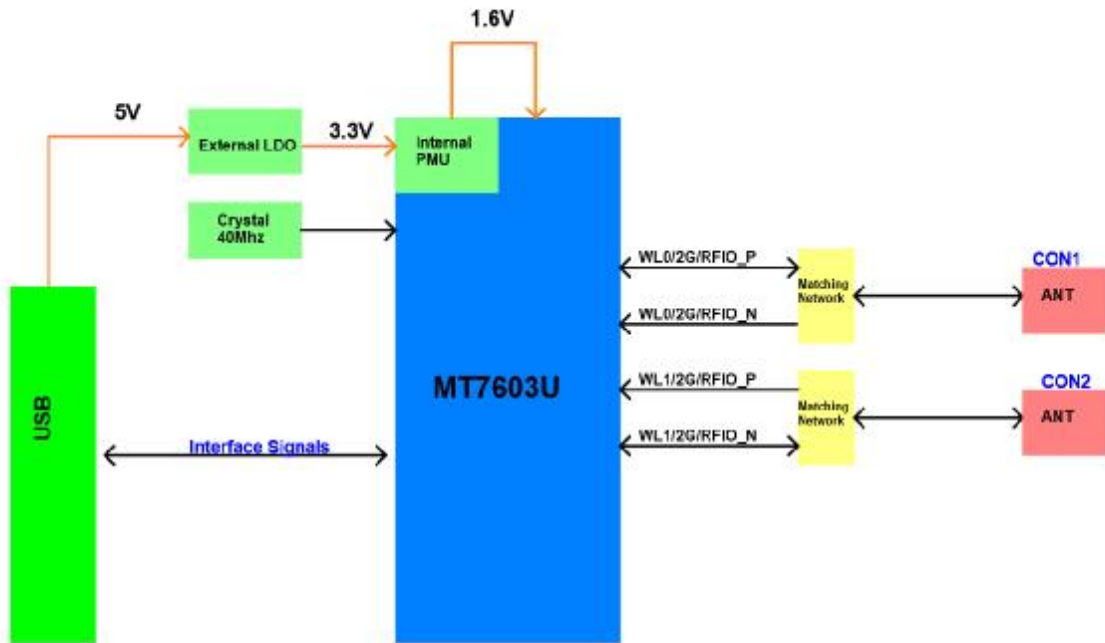

Figure 5 Typical application circuit

NOTE:

1. RF trace need to keep 50ohm impedance

6. Package information



7. Typical Solder Reflow Profile

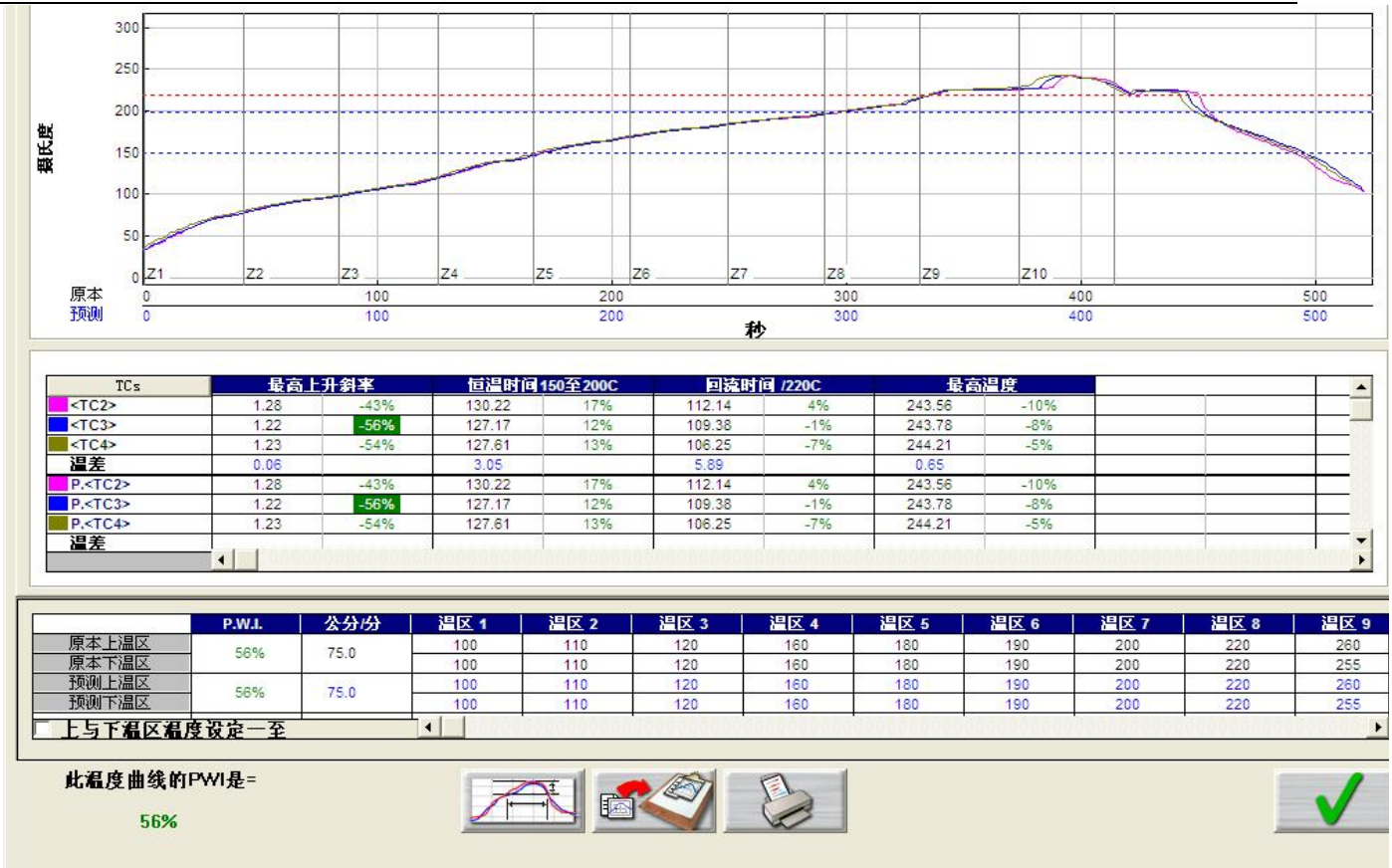

8. Precautions for use

1. Plus handle the module under ESD protection.
2. Reflow soldering shall be done according to the solder reflow profile. Peak temperature 245°C.
3. Products require baking before mounting if humidity indicator cards reads >30% temp <30 degree C, humidity < 70% RH, over 96 hours.
Baking condition: 125 degree C, 12 hours
Baking times: 1 time
4. Storage Condition: Moisture barrier bag must be stored under 30 degree C, humidity under 85% RH. The calculated shelf life for the dry packed product shall be a 12 months from the bag seal date. Humidity indicator cards must be blue, <30%.

FCC Statement

This device complies with part 15 of the FCC rules. Operation is subject to the following two conditions: (1) this device may not cause harmful interference, and (2) this device must accept any interference received, including interference that may cause undesired operation.

Changes or modifications not expressly approved by the party responsible for compliance could void the user's authority to operate the equipment.

NOTE: This equipment has been tested and found to comply with the limits for a Class B digital device, pursuant to part 15 of the FCC Rules. These limits are designed to provide reasonable protection against harmful interference in a residential installation. This equipment generates uses and can radiate radio frequency energy and, if not installed and used in accordance with the instructions, may cause harmful interference to radio communications. However, there is no guarantee that interference will not occur in a particular installation. If this equipment does cause harmful interference to radio or television reception, which can be determined by turning the equipment off and on, the user is encouraged to try to correct the interference by one or more of the following measures:

- Reorient or relocate the receiving antenna.
- Increase the separation between the equipment and receiver.
- Connect the equipment into an outlet on a circuit different from that to which the receiver is connected.
- Consult the dealer or an experienced radio/TV technician for help important announcement

Important Note:

Radiation Exposure Statement

This equipment complies with FCC radiation exposure limits set forth for an uncontrolled environment. This equipment should be installed and operated with minimum distance 20cm between the radiator and your body.

This transmitter must not be co-located or operating in conjunction with any other antenna or transmitter.

Country Code selection feature to be disabled for products marketed to the US/Canada.

This device is intended only for OEM integrators under the following conditions:

1. The antenna must be installed such that 20 cm is maintained between the antenna and users, and
2. The transmitter module may not be co-located with any other transmitter or antenna,
3. For all products market in US, OEM has to limit the operation channels in CH1 to CH11 for 2.4G band by supplied firmware programming tool. OEM shall not supply any tool or info to the end-user regarding to Regulatory Domain change. (if modular only test Channel 1-11)

As long as the three conditions above are met, further transmitter testing will not be required. However, the OEM integrator is still responsible for testing their end-product for any additional compliance requirements required with this module installed.

Important Note:

In the event that these conditions cannot be met (for example certain laptop configurations or co-location with another transmitter), then the FCC authorization is no longer considered valid and the FCC ID cannot be used on the final product. In these circumstances, the OEM integrator will be responsible for re-evaluating the end product (including the transmitter) and obtaining a separate FCC authorization.

End Product Labeling

The final end product must be labeled in a visible area with the following" Contains FCC ID: **2AL6KBL-M7603NU4** ".

Manual Information to the End User

The OEM integrator has to be aware not to provide information to the end user regarding how to install or remove this RF module in the user's manual of the end product which integrates this module.

The end user manual shall include all required regulatory information/warning as show in this manual.

Integration instructions for host product manufacturers according to KDB 996369 D03 OEM Manual v01

2.2 List of applicable FCC rules

CFR 47 FCC PART 15 SUBPART C has been investigated. It is applicable to the modular transmitter

2.3 Specific operational use conditions

This module is stand-alone modular. If the end product will involve the Multiple simultaneously transmitting condition or different operational conditions for a stand-alone modular transmitter in a host, host manufacturer have to consult with module manufacturer for the installation method in end system.

2.4 Limited module procedures

This module is Limited single modular without shielding, host manufacturer have to consult with module manufacturer for the module limiting conditions when integrate the module in the host. module manufacturer should reviews detailed test data or host designs prior to giving the host manufacturer approval.

2.5 Trace antenna designs

Not applicable

2.6 RF exposure considerations

This equipment complies with FCC radiation exposure limits set forth for an uncontrolled environment. This equipment should be installed and operated with minimum distance 20cm between the radiator & your body.

2.7 Antennas

antenna types listed below, with the maximum permissible gain indicated. Antenna types not included in this list that have a gain greater than the maximum gain indicated for any type listed are strictly prohibited for use with this device.

Model	Type	Connector	Peak gain (dBi)				
			2400-2483.5 MHz	5150-5250 MHz	5250-5350 MHz	5470-5725 MHz	5725-5850 MHz
BAT-POLK-WIFI	Dipole	RF-SMA	5.0dBi	/	/	/	/
BAT-POLK-WIFI	Dipole	RF-SMA	5.0dBi	/	/	/	/

2.8 Label and compliance information

The final end product must be labeled in a visible area with the following" Contains FCC ID:2AL6KBL-M7603NU4".

2.9 Information on test modes and additional testing requirements

Host manufacturer which install this modular with limit modular approval should perform the test of radiated emission and spurious emission according to FCC part 15C:15.247 and 15.209 requirement, only if the test result comply with FCC part 15.247 and 15.209 requirement, then the host can be sold legally.

2.10 Additional testing, Part 15 Subpart B disclaimer

Host manufacturer is responsible for compliance of the host system with module installed with all other applicable requirements for the system such as Part 15 B.