



BL-M6158NS1

802.11n 150Mbps WiFi

SDIO Module Specification

SHENZHEN BILIAN ELECTRONIC CO., LTD

Add: 10~11/F, Building 1A, Huaqiang idea park, Guangming district, Shenzhen. Guangdong, China

Web: www.b-link.net.cn

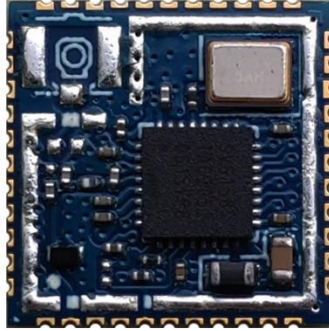

Module Name: BL-M6158NS1

Module Type: 802.11b/g/n 150Mbps SDIO Module

Revision: V1.0

Customer Approval:

Company:

Title:

Signature:

Date:

BL-link Approval:

Title:

Signature:

Date:

Revision History

Revision	Summary	Release Date
0.1	Initial release	2021-01-25
1.0	Final release	2021-03-23

1. Introduction

BL-M6158NS1 wireless SDIO module is designed base on SV6158. It operates at 2.4~2.4835GHz supports IEEE802.11b/g/n 1T1R, wireless data rate can reach up to 150Mbps. The SDIO interface complies with SDIO 1.1/2.0 and SPI. It supports external antenna, which adapts different kinds of work environment. It' s easy and convenient to connect wireless network.

1.1 Features

- Operating Frequencies: 2.4~2.4835GHz
- Host Interface is SDIO
- IEEE Standards: IEEE 802.11b/g/n
- Wireless data rate can reach up to 150Mbps
- Connect to external antenna through Half hole pads
- Power Supply: 3.3V±0.2V main power supply

1.2 Block Diagram

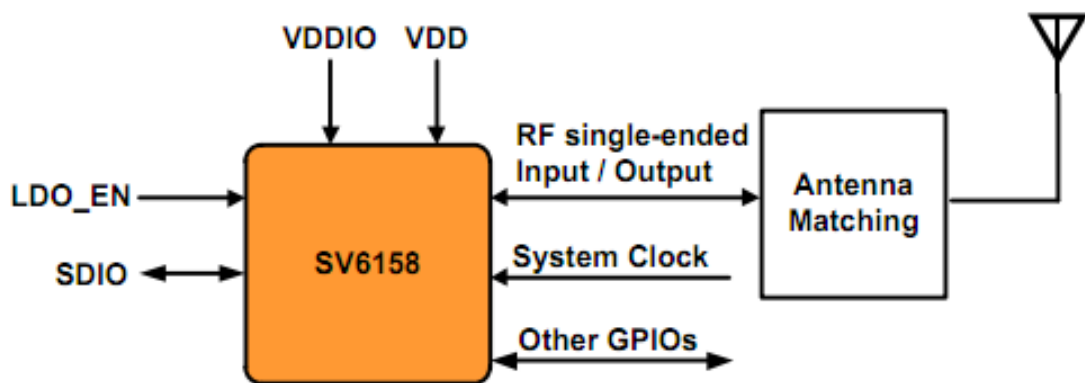

SV6158 System Block Diagram

1.3 General Specifications

Module Name	BL-M6158NS1, WiFi Module
Chipset	SV6158
WiFi Standards	IEEE802.11b/g/n/, 1T1R, 2.4G, 150Mbps (Max)
Host Interface	SDIO2.0
Antenna	Connect to external antenna through Half hole pads
Dimension	SMD 44Pins, 12.0*12.0*1.5mm (L*W*H)
Power Supply	DC 3.3V±0.2V @350 mA (Max)
Operation Temperature	-20°C to +50°C
Operation Humidity	10% to 95% RH (Non-Condensing)
Storage Temperature	-40°C to +85°C
Storage Humidity	10% to 95% RH (Non-Condensing)

2. Pin Assignments

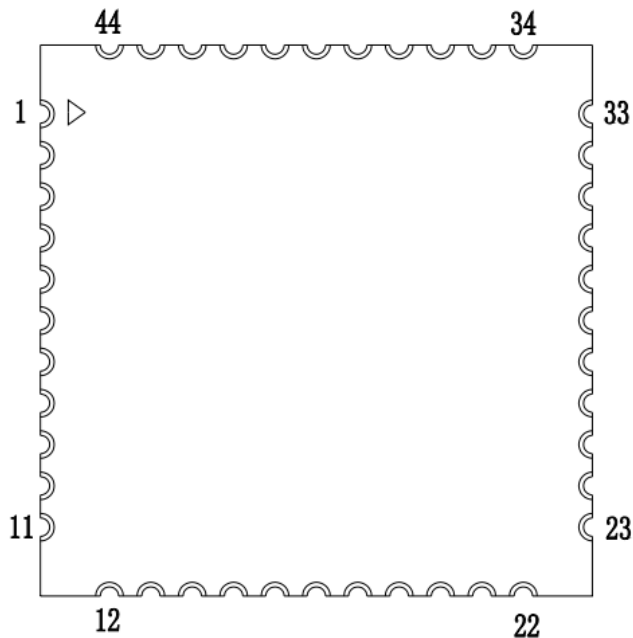

(Top view)

2.1 Pin Definition

No	Pin Name	Type	Description	Supply
1	GND	P	Ground	
2	RF	I/O	WLAN RF pad/2.4G	
3	GND	P	Ground	
4	NC	/	NC	
5	GPIO12	I/O	Strapping Purpose I/O Pins	
6	NC	/	NC	
7	NC	/	NC	
8	NC	/	NC	
9	VDD	P	VDD3.3V power supply	
10	NC	/	NC	
11	NC	/	NC	
12	LDO_EN	I	Reset signal to power down IC	
13	WAKE_UP_HOST	I/O	General Purpose I/O Pins	
14	SD_D2	I/O	SDIO data 2	
15	SD_D3	I/O	SDIO data 3	
16	SD_CMD	I/O	SDIO command	
17	SD_CLK	I	SDIO clock	
18	SD_D0	I/O	SDIO data 0	
19	SD_D1	I/O	SDIO data 1	
20	GND	P	Ground	
21	NC	/	NC	
22	VDDIO	P	VDDIO3.3V power supply	
23	NC	/	NC	
24	NC	/	NC	
25	NC	/	NC	
26	NC	/	NC	
27	NC	/	NC	
28	NC	/	NC	
29	NC	/	NC	
30	NC	/	NC	
31	GND	P	Ground	

32	NC	/	NC	
33	GND	P	Ground	
34	NC	/	NC	
35	NC	/	NC	
36	GND	P	Ground	
37	GPIO00/UART_LOG_RX	I/O	General Purpose I/O Pins	
38	GPIO01/UART_LOG_TX	I/O	General Purpose I/O Pins	
39	NC	/	NC	
40	NC	/	NC	
41	NC	/	NC	
42	NC	/	NC	
43	NC	/	NC	
44	NC	/	NC	

P: Power, I: Input, O: Output, I/O: In/Output, RF: Analog RF Port

3. Electrical and Thermal Specifications

3.1 Recommended Operating Conditions

Parameters	Min	Typ	Max	Units	
Ambient Operating Temperature	-20	25	50	°C	
External Antenna VSWR		1.7	2.0	/	
Supply Voltage	VDD	3.1	3.3	3.5	V

3.2 Digital I/O DC Specifications

Symbol	Parameter	Min	Typ	Max	Units
VIH	Input High Voltage	2.0		3.6	V
VIL	Input Low Voltage	-0.3	0	0.8	V
VOH+	Output High Voltage	2.4			V
VOL-	Output Low Voltage			0.4	V

3.3 Power On Sequence

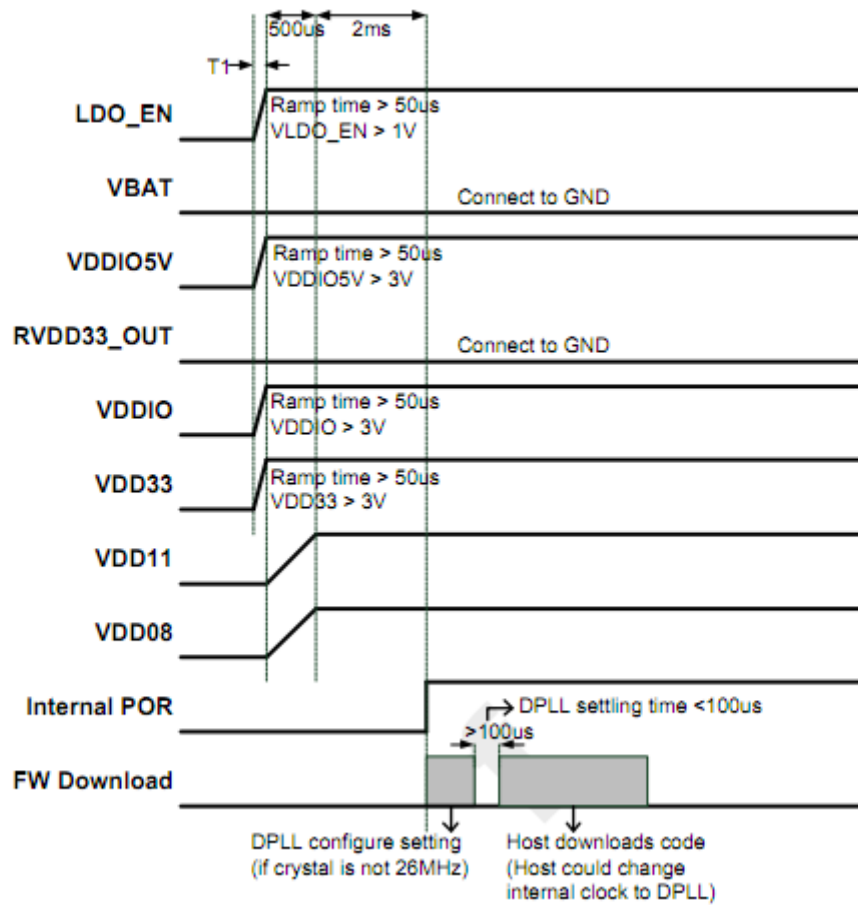

3.4 Current Consumption

Conditions: VDD=3.3V, Ta = 25 °C, unit: mA			
Supply current	VDD Current(average)		
	Typ	Max	Units
WiFi Unassociated(Linux Driver)	118	326	mA
2.4G 1Mbps TX(RF-Test) 17	212	220	mA
2.4G 1Mbps RX(RF-Test)	80	85	mA
2.4G 11Mbps TX(RF-Test) 17	200	210	mA
2.4G 11Mbps RX(RF-Test)	80	85	mA
2.4G 6Mbps TX(RF-Test) 14	182	192	mA
2.4G 6Mbps RX(RF-Test)	80	85	mA
2.4G 54Mbps TX(RF-Test) 14	182	192	mA
2.4G 54Mbps RX(RF-Test)	80	85	mA

2.4G MCS0(HT20) TX(RF-Test) 14	215	225	mA
2.4G MCS0(HT20) RX(RF-Test)	80	85	mA
2.4G MCS7(HT20) TX(RF-Test) 14	183	193	mA
2.4G MCS7(HT20) RX(RF-Test)	80	85	mA
2.4G MCS0(HT40) TX(RF-Test) 14	183	193	mA
2.4G MCS0(HT40) RX(RF-Test)	80	85	mA
2.4G MCS7(HT40) TX(RF-Test) 14	183	193	mA
2.4G MCS7(HT40) RX(RF-Test)	80	85	mA

4. Interface Functional and Timing Specifications

4.1 SDIO Interface Functional Description

Complies With SDIO 1.1/2.0/3.0 for WLAN With clock up to 208MHz, for more Information please reference “SD specifications Part1 Physical Layer Specification Version 3.01” .

4.2 SDIO Interface Timing

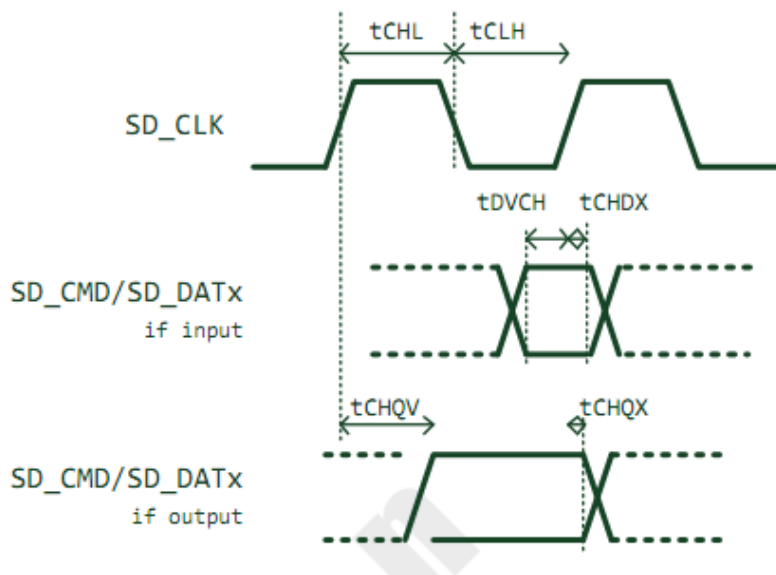

Symbol	Parameter	Condition	Min.	Typ.	Max.	Units
f _{pp}	Clock Frequency	SDR12/25/50	0	-	50	MHz
t _{TLH}	Clock rise time	SDR12/25/50	7	-	-	ns
t _{THL}	Clock fall time	SDR12/25/50	7	-	-	ns
t _{ISU}	Input set-up time	SDR12/25/50	6	-	-	ns
t _{IH}	Input hold time	SDR12/25/50	2	-	-	ns
T _{OOZY}	Output Delay time during Data Transfer Mode	SDR12/25/50	-	-	14	ns
T _{oH}	Output Hold time	SDR12/25/50	2.5	-	-	ns

5. WiFi & Bluetooth RF Specifications

5.1 2.4G WiFi RF Specification

Conditions : VDD=3.3V ; Ta:25°C			
Features	Description		
WLAN Standard	IEEE 802.11b/g/n		
Frequency Range	2.4~2.4835GHz (2.4GHz ISM Band)		
Channels	Ch1~Ch13 (For 20MHz Channels)		
Modulation	802.11b (DSSS): DBPSK, DQPSK, CCK; 802.11g (OFDM): BPSK, QPSK, QAM16, QAM64; 802.11n (OFDM): BPSK, QPSK, QAM16, QAM64;		
Data Rate	802.11b: 1, 2, 5.5, 11Mbps; 802.11g: 6, 9, 12, 18, 24, 36, 48, 54Mbps; 802.11n (HT20): MCS0~MCS7(1T1R_SISO) 6.5~72.2Mbps; 802.11n (HT40): MCS0~MCS7(1T1R_SISO) 13.5~150Mbps;		
Frequency Tolerance	≤ ±25ppm		
2.4G Transmitter Specifications			
TX Rate	TX Power	TX Power Tolerance	EVM
802.11b@1~11Mbps	17dBm	±1.5dBm	≤-10dB
802.11g@6Mbps	17dBm	±1.5dBm	≤-10dB
802.11g@54Mbps	14dBm	±1.5dBm	≤-25dB
802.11n@HT20_MCS0	14dBm	±1.5dBm	≤-10dB
802.11n@HT20_MCS7	14dBm	±1.5dBm	≤-27dB

802.11n@HT40_MCS0	14dBm	±1.5dBm	≤-10dB
802.11n@HT40_MCS7	14dBm	±1.5dBm	≤-27dB
2.4G Receiver Specifications			
RX Rate	Min Input Level(Typ)	Max Input Level(Typ)	PER
802.11b@1Mbps	-92dBm	-10dBm	< 8%
802.11b@11Mbps	-85dBm	-10dBm	< 8%
802.11g@6Mbps	-84dBm	-20dBm	< 10%
802.11g@54Mbps	-68dBm	-20dBm	< 10%
802.11n@HT20_MCS0	-84dBm	-20dBm	< 10%
802.11n@HT20_MCS7	-65dBm	-20dBm	< 10%
802.11n@HT40_MCS0	-84dBm	-20dBm	< 10%
802.11n@HT40_MCS7	-65dBm	-20dBm	< 10%

6. Mechanical Specifications

6.1 Module Outline Drawing

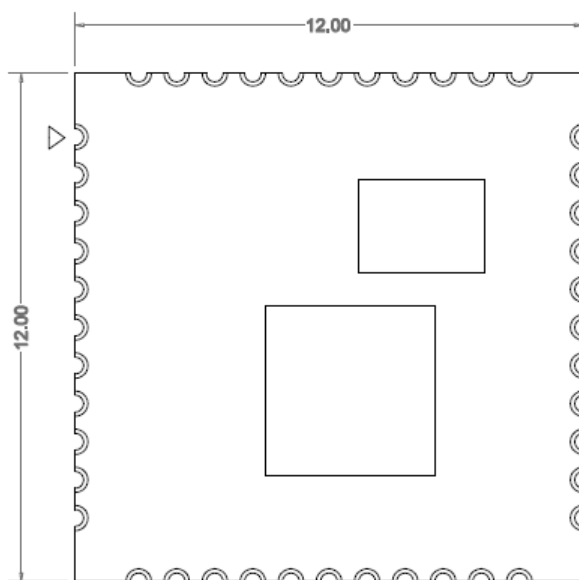

top view

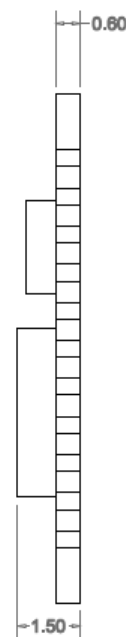

side view

Module dimension: 12.0*12.0*1.50mm (L*W*H; Tolerance: ±0.15mm)

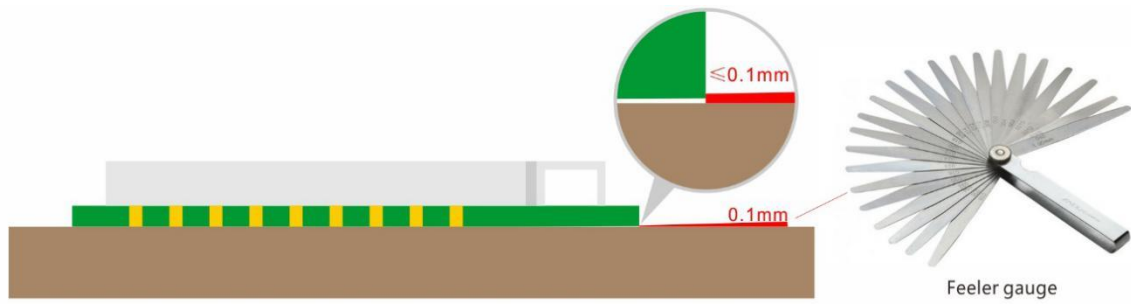

Module Bow and Twist: $\leq 0.1\text{mm}$

6.2 Mechanical Dimensions

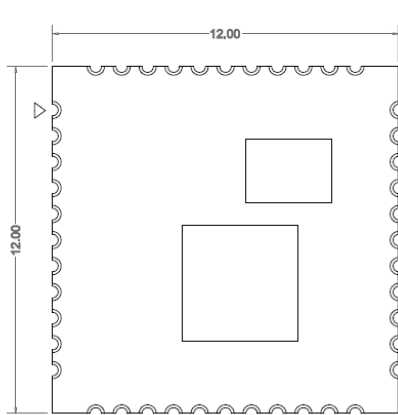

top view

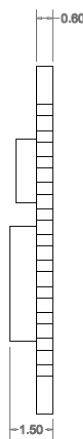

side view

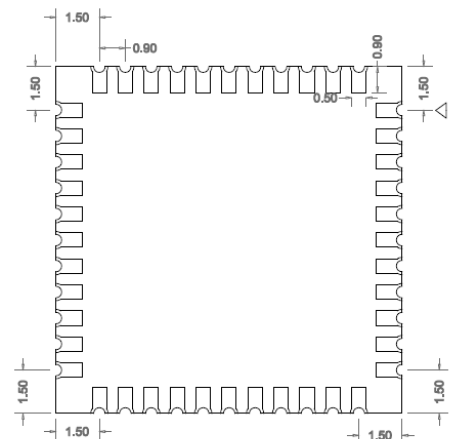

bottom view

7. Application Information

7.1 Typical Application Circuit

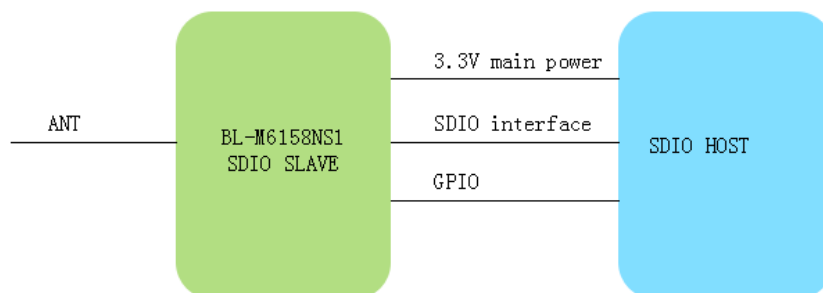

7.2 Recommend PCB Layout Footprint

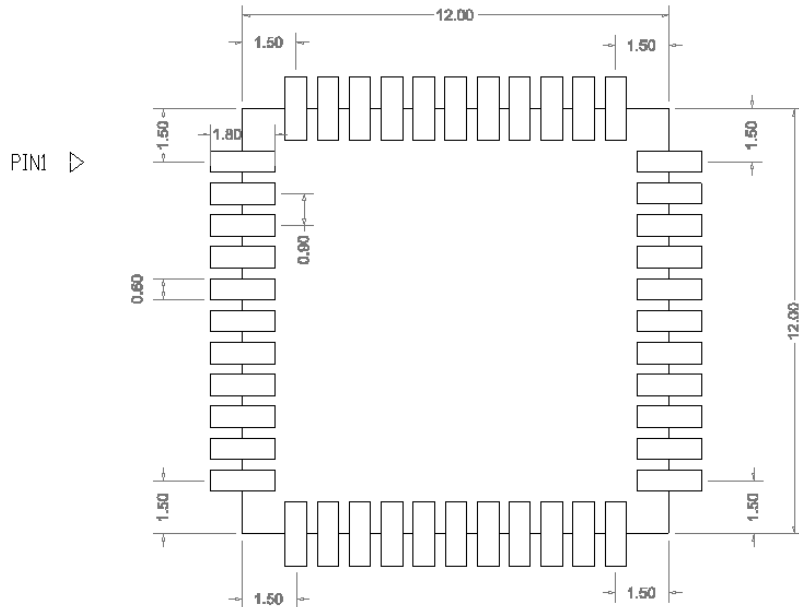

7.3 Reflow Soldering Standard Conditions

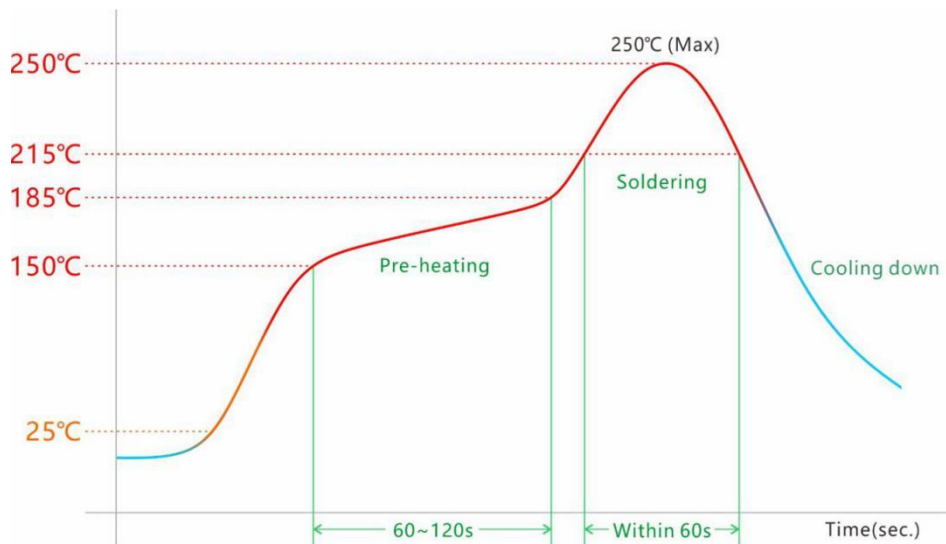

Please use the reflow within 2 times.
Set up the highest temperature within 250°C.

8. Key Components Of Module

No.	Parts	Specification	Manufacturer	Note
1	Chipset	SV6158	iComm-semi	
2	PCB	BL-M6158NS1	Shenzhen Tie Fa Technology	
			Quzhou Sunlord Electronics Co., Ltd	
			Jiangsu Lantek Electronics Tech Co., Ltd.	
3	Crystal	24MHZ-10PPM-12p-3225	Lucki Electronics Co., Ltd	
			Shenzhen Kaiyuexiang Electronics Co., Ltd	
			Chengde Oscillator Electronic Technology Co., Ltd.	

9. Package and Storage Information

9.1 Package Dimensions

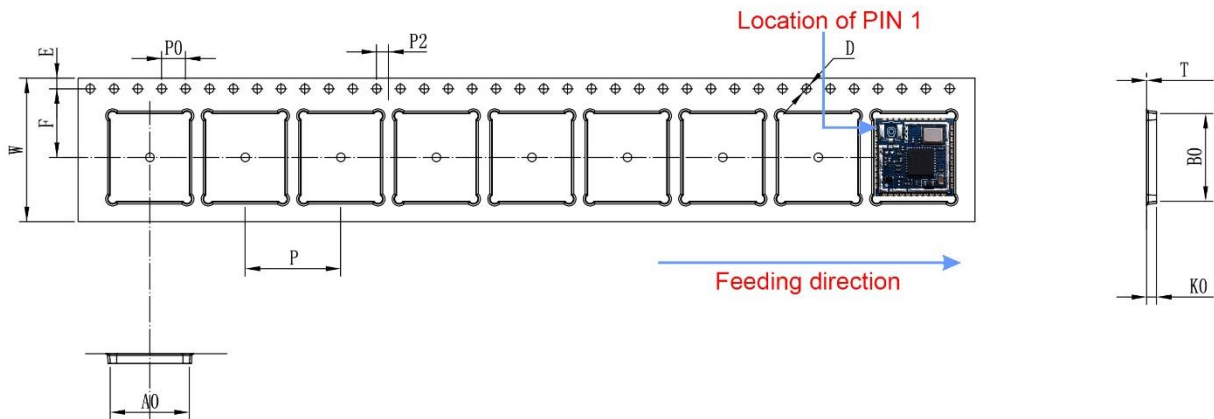

ITEM	W	A0	B0	K0	E	F	P	P0	P2	D	T
DIM	24.00±0.3	12.85±0.1	14.30±0.1	1.85±0.1	1.75±0.1	11.5±0.1	16.00±0.1	4.00±0.1	2.00±0.1	Ø1.5±0.1	0.30±0.05



Package specification:

1. 2000 modules per roll and 10,000 modules per box.
2. Outer box size: 37.5*36*29cm.
3. The diameter of the blue environment-friendly rubber plate is 13 inches, with a total thickness of 25.3mm (with a width of 21.3mm carrying belt).
4. Put 1 package of dry agent (20g) and humidity card in each anti-static vacuum bag.
5. Each carton is packed with 5 boxes.

8.1 Storage Conditions

Absolute Maximum Ratings:

Storage temperature: -45°C to +85°C

Storage humidity: 10% to 95% RH (Non-Condensing)

Recommended Storage Conditions:

Storage temperature: 5°C to +40°C

Storage humidity: 20% to 90% RH Storage temperature: -45°C to +85°C

Please use this Module within 12month after vacuum-packaged.

The Module shall be stored without opening the packing.

After the packing opened, the Module shall be used within 72hours.

When the color of the humidity indicator in the packing changed, the Module shall be baked before soldering.

Baking condition: 60°C, 24hours, 1time.

ESD Sensitivity:

The Module is a static-sensitive electronic device.

Do not operate or store near strong electrostatic fields.

Take proper ESD precautions!

The Module ESD supports $\pm 3\text{KV}$,

TVS diode is suggested if need to get a better ESD sensitivity.

FCC WARNING

FCC Caution: Any changes or modifications not expressly approved by the party responsible for compliance could void the user's authority to operate this equipment.

This device complies with Part 15 of the FCC Rules.

Operation is subject to the following two conditions: (1) This device may not cause harmful interference, and (2) this device must accept any interference received, including interference that may cause undesired operation.

This device and its antenna(s) must not be co-located or operating in conjunction with any other antenna or transmitter.

15.105 Information to the user.

(b) For a Class B digital device or peripheral, the instructions furnished the user shall include the following or similar statement, placed in a prominent location in the text of the manual:

Note: This equipment has been tested and found to comply with the limits for a Class B digital device, pursuant to part 15 of the FCC Rules. These limits are designed to provide reasonable protection against harmful interference in a residential installation. This equipment generates, uses and can radiate radio frequency energy and, if not installed and used in accordance with the instructions, may cause harmful interference to radio communications. However, there is no guarantee that interference will not occur in a particular installation. If this equipment does cause harmful interference to radio or television reception, which can be determined by turning the equipment off and on, the user is encouraged to try to correct the interference by one or more of the following measures:

- Reorient or relocate the receiving antenna.
- Increase the separation between the equipment and receiver.
- Connect the equipment into an outlet on a circuit different from that to which the receiver is connected.
- Consult the dealer or an experienced radio/TV technician for help.

This equipment complies with FCC radiation exposure limits set forth for an uncontrolled environment. This equipment should be installed and operated with minimum distance 20cm between the radiator and your body.

antenna or transmitter.

The availability of some specific channels and/or operational frequency bands are country dependent and are firmware programmed at the factory to match the intended destination.

The firmware setting is not accessible by the end user.

The final end product must be labelled in a visible area with the following:

“Contains Transmitter Module 2AL6KBL-M7663BU1”

The module can be used for camera with 2dBi antenna. The host manufacturer installing this module into their product must ensure that the final compost product complies with the FCC requirements by a technical assessment or evaluation to provide information to the end user regarding how to install or remove this RF module in the user's manual of the end product which integrates this module. The end user manual shall include all required regulatory information/warning as show in this manual.

Requirement per KDB996369 D03

2.2 List of applicable FCC rules

List the FCC rules that are applicable to the modular transmitter. These are the rules that specifically establish the bands of operation, the power, spurious emissions, and operating fundamental frequencies. DO NOT list compliance to unintentional-radiator rules (Part 15 Subpart B) since that is not a condition of a module grant that is extended to a host manufacturer. See also Section 2.10 below concerning the need to notify host manufacturers that further testing is required.³

Explanation: This module meets the requirements of FCC part 15C (15.247). It specifically identified AC Power Line Conducted Emission, Radiated Spurious emissions, Band edge and RF Conducted Spurious Emissions, Conducted Peak Output Power, Bandwidth, Power Spectral Density, Antenna Requirement.

Summarize the specific operational use conditions

Describe use conditions that are applicable to the modular transmitter, including for example any limits on antennas, etc. For example, if point-to-point antennas are used that require reduction in power or compensation for cable loss, then this information must be in the instructions. If the use condition limitations extend to professional users, then instructions must state that this information also extends to the host manufacturer's instruction manual. In addition, certain information may also be needed, such as peak gain per frequency band and minimum gain, specifically for master devices in 5 GHz DFS bands.

Explanation: The EUT has one PCB antenna, the antenna can not be replaced by other authorized antennas.

2.3 Limited module procedures

If a modular transmitter is approved as a "limited module," then the module manufacturer is responsible for approving the host environment that the limited module is used with. The manufacturer of a limited module must describe, both in the filing and in the installation instructions, the alternative means that the limited module manufacturer uses to verify that the host meets the necessary requirements to satisfy the module limiting conditions.

A limited module manufacturer has the flexibility to define its alternative method to address the conditions that limit the initial approval, such as: shielding, minimum signaling amplitude, buffered modulation/data inputs, or power supply regulation. The alternative method could include that the limited

module manufacturer reviews detailed test data or host designs prior to giving the host manufacturer approval.

This limited module procedure is also applicable for RF exposure evaluation when it is necessary to demonstrate compliance in a specific host. The module manufacturer must state how control of the product into which the modular transmitter will be installed will be maintained such that full compliance of the product is always ensured. For additional hosts other than the specific host originally granted with a limited

module, a Class II permissive change is required on the module grant to register the additional host as a specific host also approved with the module.

Explanation: The module is a single module.

2.6 RF exposure considerations

It is essential for module grantees to clearly and explicitly state the RF exposure conditions that permit a host product manufacturer to use the module. Two types of instructions are required for RF exposure information: (1) to the host product manufacturer, to define the application conditions (mobile, portable – xx cm from a person's body); and (2) additional text needed for the host product manufacturer to provide to end users in their end-product manuals. If RF exposure statements and use conditions are not provided, then the host product manufacturer is required to take responsibility of the module through a change in FCC ID (new application).

Explanation: This module complies with FCC RF radiation exposure limits set forth for an uncontrolled environment, This equipment should be installed and operated with a minimum distance of 20 centimeters between the radiator and your body." This module is designed to comply with the FCC statement, FCC ID is: 2AL6KBL-M7663BU1.

2.7 Antennas

A list of antennas included in the application for certification must be provided in the instructions. For modular transmitters approved as limited modules, all applicable professional installer instructions must be included as part of the information to the host product manufacturer. The antenna list shall also identify the antenna types (monopole, PIFA, dipole, etc. (note that for example an "omni-directional antenna" is not considered to be a specific "antenna type"))).

For situations where the host product manufacturer is responsible for an external connector, for example with an RF pin and antenna trace design, the integration instructions shall inform the installer that unique antenna connector must be used on the Part 15 authorized transmitters used in the host product.

The module manufacturers shall provide a list of acceptable unique connectors.

Explanation: The EUT has one PCB antenna, the antenna can not be replaced by other authorized antennas.

2.8 Label and compliance information

Grantees are responsible for the continued compliance of their modules to the FCC rules. This

includes advising host product manufacturers that they need to provide a physical or e-label stating "Contains FCC ID" with their finished product. See Guidelines for Labeling and User Information for RF Devices – KDB Publication 784748.

Explanation: The host system using this module, should have label in a visible area indicated the following texts: "Contains FCC ID: 2AL6KBL-M7663BU1.

2.9 Information on test modes and additional testing requirements

Additional guidance for testing host products is given in KDB Publication 996369 D04 Module Integration Guide. Test modes should take into consideration different operational conditions for a stand-alone modular transmitter in a host, as well as for multiple simultaneously transmitting modules or other transmitters in a host product.

The grantee should provide information on how to configure test modes for host product evaluation for different operational conditions for a stand-alone modular transmitter in a host, versus with multiple, simultaneously transmitting modules or other transmitters in a host.

Grantees can increase the utility of their modular transmitters by providing special means, modes, or instructions that simulates or characterizes a connection by enabling a transmitter. This can greatly simplify a host manufacturer's determination that a module as installed in a host complies with FCC requirements.

Explanation: ShenZhen RF Crazy Technology Co., Ltd. can increase the utility of our modular transmitters by providing instructions that simulates or characterizes a connection by enabling a transmitter.

2.10 Additional testing, Part 15 Subpart B disclaimer

The grantee should include a statement that the modular transmitter is only FCC authorized for the specific rule parts (i.e., FCC transmitter rules) listed on the grant, and that the host product manufacturer is responsible for compliance to any other FCC rules that apply to the host not covered by the modular transmitter grant of certification. If the grantee markets their product

as being Part 15

Subpart B compliant (when it also contains unintentional-radiator digital circuitry), then the grantee shall provide a notice stating that the final host product still requires Part 15 Subpart B compliance testing with the modular transmitter installed.

Explanation: The module without unintentional-radiator digital circuitry, so the module does not require an evaluation by FCC Part 15 Subpart B. The host should be evaluated by the FCC Subpart B.