

Measurement and Test Report For Shenzhen Qiuyu Electronic Co., Ltd

FCC ID:2AL64-QY-BWPT

FCC Rule(s)/Methods:	FCC CFR Title 47 Part 15 Subpart E Section 15.407 ANSI C63.10:2013
Product Description:	Computer Tablet
Trademark	BWJBSW
Model/Type reference.:	QR1010, QR1012, QR1013, QR1015, QR1016, QR1018, QR1020, QR1021, QR1022, QR1025, QR1026, QR1028, QR1029, QR1030, QR1032, QR1035, QR1036, QR1038, QR1040, QR1042, QR1045, QR1046, QR1048, QR1050, QR1051, QR1051W, QR1051GL, QZ1010, QZ1012, QZ1015, QZ1016, QZ1018, QZ1020, QZ1021, QZ1022, QZ1025, QZ1026, QZ1028, QZ1029, QZ1030, QZ1032, QZ1035, QZ1036, QZ1038, QZ1040, QZ1042, QZ1045, QZ1046, QZ1048, QZ1050, QZ1051, QZ1052, QZ1054, QZ1056, QZ1058, QZ1060, QZ1090, QZ1090W, QZ1090GL, QZ1095, QZ1095W, QZ1095GL, QZ1197, QZ1197W, QZ1197GL, QZ1330, QZ1330W, QZ1330GL, QZ1410, QZ1410W, QZ1410GL, QA1010, QA1010W, QA1010GL, QA1051, QA1051W, QA1051GL, QA1036, QA1036W, QA1036GL, QA1095, QA1095W, QA1095GL, QA1330, QA1330W, QA1330GL, QA1410, QA1410W, QA1410GL, QA1412, QZ1416, QZ1418, QZ1420, QZ1412GL, QZ1416GL, QZ1418GL, QZ1420GL, QM1010, QM1010W, QM1010GL, QM1012, QM1013, QM1015, QM1016, QM1018, QM1020, QM1021, QM1022, QM1025, QM1026, QM1028, QM1029, QM1030, QM1036, QM1036W, QM1036GL, QM1038, QM1040, QM1042, QM1051, QM1051W, QM1051GL, QM1036, QM1036GL, QM1095, QM1095W, QM1095GL, QM1197, QM1191W, QM1197GL, QM1330, QM1330W, QM1330GL, QM1410, QM1410W, QM1410GL, QM1412, QM1416, QM109GL, QA1295, QA1295W, QA1295GL, QZ1295, QZ1295W, QM1295GL, QM1295, QM1295W, QM1295GL, QM706, QM706GL, QM806GL, QM7082, QM8082, QM8017, QM1066, QM1067, QM1082, QM1016, QM8016, QM066GL, QM806G3, QM106G3, QM706G3, QM8086GL, QM106GL, QM10T10GL, HT12
Report No.:	BSL2405208275098F-3
Date of receipt of test item:	May 24, 2024
Date of sampling:	May 28, 2024
Tested Date:	Jun. 02, 2024 to Jun. 05, 2024

Issued Date: Jun. 06, 2024
Tested By: Lris Yao/ Engineer
Reviewed By: Levi Xiao/ EMC Manager
Approved & Authorized By: Salon Ouyang / PSQ Manager

Lris Yao
Levi Xiao
Salon Ouyang

BSL Testing Co.,LTD.

1/F, Building B, Xinshidai GR Park, Shiyan Street, Bao'an District, Shenzhen, Shiyan Street, Bao'an District, Shenzhen, Guangdong, 518052, People's Republic of China
Tel: 400-882-9628 Fax: 86- 755-26508703

Table of Contents	Page
1. VERSION	5
2.SUMMARY OF TEST RESULTS	6
2.1 TEST FACILITY	7
2.2 MEASUREMENT UNCERTAINTY	7
3. GENERAL INFORMATION	8
3.1 GENERAL DESCRIPTION OF EUT	8
3.3 BLOCK DIGRAM SHOWING THE CONFIGURATION OF SYSTEM TESTED	10
3.4 DESCRIPTION OF SUPPORT UNITS	10
3.5 EQUIPMENTS LIST FOR ALL TEST ITEMS	11
4.EMC EMISSION TEST	13
4.1 CONDUCTED EMISSION MEASUREMENT	13
4.1.1 POWER LINE CONDUCTED EMISSION Limits	13
4.1.2 TEST PROCEDURE	13
4.1.3 DEVIATION FROM TEST STANDARD	13
4.1.4 TEST SETUP	14
4.1.5 EUT OPERATING CONDITIONS	14
4.1.6 TEST RESULT (Worst case 802.11a 5180MHz)	15
4.2 RADIATED EMISSION MEASUREMENT	17
4.2.1 APPLICABLE STANDARD	17
4.2.2 CONFORMANCE LIMIT	17
4.2.3 MEASURING INSTRUMENTS	18
4.2.4 TEST CONFIGURATION	18
4.2.5 TEST PROCEDURE	19
4.2.6 TEST RESULT	20
5.POWER SPECTRAL DENSITY TEST	27
5.1 APPLIED PROCEDURES / LIMIT	27
5.2 TEST PROCEDURE	28
5.3 DEVIATION FROM STANDARD	28
5.4 TEST METHOD	28
5.5 TEST SETUP	28
5.6 EUT OPERATION CONDITIONS	28
5.7 TEST RESULTS	29
6.26DB & 6DB & 99% EMISSION BANDWIDTH	34
6.1 APPLIED PROCEDURES / LIMIT	34
6.2 TEST PROCEDURE	34
6.3 EUT OPERATION CONDITIONS	35
6.4 TEST RESULTS	35

Table of Contents	Page
7.MAXIMUM CONDUCTED OUTPUT POWER	40
7.1 PPLIED PROCEDURES / LIMIT	40
7.2 TEST PROCEDURE	40
7.3 DEVIATION FROM STANDARD	41
7.4 TEST SETUP	41
7.5 EUT OPERATION CONDITIONS	41
7.6 TEST RESULTS	42
8.OUT OF BAND EMISSIONS	43
8.1 APPLICABLE STANDARD	43
8.2 TEST PROCEDURE	44
8.3 DEVIATION FROM STANDARD	44
8.4 TEST SETUP	44
8.5 EUT OPERATION CONDITIONS	45
8.6 TEST RESULTS	45
10.Frequency Stability Measurement	53
10.1 LIMIT	53
10.2 TEST PROCEDURES	53
10.3 TEST SETUP LAYOUT	53
10.4 EUT OPERATION DURING TEST	53
10.5 TEST RESULTS	53
11. DUTY CYCLE	59
12.ANTENNA REQUIREMENT	64
13. TEST SETUP PHOTO	65
14. EUT CONSTRUCTIONAL DETAILS	65

1. VERSION

Report No.	Version	Description	Approved
BSL2405208275098F-3	Rev.01	Initial issue of report	Jun. 06, 2024

2.SUMMARY OF TEST RESULTS

Test procedures according to the technical standards:

FCC Part15 (15.407) , Subpart E			
Standard Section	Test Item	Judgment	Remark
15.209(a) 15.407 (b)	Spurious Radiated Emissions	PASS	
Duty Cycle	KDB 789033	--	
15.207	Conducted Emission	PASS	
15.407 (a)(12) 2.1049	26 dB and 99% Emission Bandwidth	PASS	
15.407(e)	6 dB bandwidth	PASS	
15.407 (a)(1) 15.407 (a)(3)	Maximum Conducted Output Power&Eirp	PASS	
2.1051, 15.407(b)(1) 15.407(b)(4)	Band Edge	PASS	
15.407 (a)(1) 15.407 (a)(3)	Power Spectral Density	PASS	
15.203	Antenna Requirement	PASS	

NOTE:

(1) " N/A" denotes test is not applicable in this Test Report

Test method: KDB 789033 D02 v01r02, KDB 662911 D01 Multiple Transmitter Output v02r01

2.1 TEST FACILITY

BSL TESTING CO., LTD

Add. : 1/F, Building B, Xinshidai GR Park, Shiyuan Street, Bao'an District, Shenzhen, Shiyuan Street, Bao'an District, Shenzhen, Guangdong, 518052, People's Republic of China

FCC Test Firm Registration Number: 562200

Designation Number: CN1338

IC Registered No.: 11093A

Designation Number: CN0019

2.2 MEASUREMENT UNCERTAINTY

The reported uncertainty of measurement $y \pm U$ · where expanded uncertainty U is based on a standard uncertainty multiplied by a coverage factor of $k=2$ · providing a level of confidence of approximately 95 % .

No.	Item	Uncertainty
1	3m chamber Radiated spurious emission(9KHz-30MHz)	U=4.5dB
2	3m chamber Radiated spurious emission(30MHz-1GHz)	U=4.8dB
3	3m chamber Radiated spurious emission(1GHz-6GHz)	U=4.9dB
4	3m chamber Radiated spurious emission(6GHz-40GHz)	U=5.0dB
5	Conducted disturbance	U=3.2dB
6	RF Band Edge	U=1.68dB
7	RF power conducted	U=1.86dB
8	RF conducted Spurious Emission	U=2.2dB
9	RF Occupied Bandwidth	U=1.8dB
10	RF Power Spectral Density	U=1.75dB
11	humidity uncertainty	U=5.3%
12	Temperature uncertainty	U=0.59°C

3. GENERAL INFORMATION

3.1 GENERAL DESCRIPTION OF EUT

Applicant:	Shenzhen Qiuyu Electronic Co., Ltd	
Address of applicant:	3F, Building E, Hongzhuyongqi Technology Park, Lezhujiao village, Xixiang town, Bao'an district, Shenzhen, China	
Manufacturer:	Shenzhen Qiuyu Electronic Co., Ltd	
Address of manufacturer:	3F, Building E, Hongzhuyongqi Technology Park, Lezhujiao village, Xixiang town, Bao'an district, Shenzhen, China	
Product Name:	Computer Tablet	
Model No.:	<p>QR1010, QR1012, QR1013, QR1015, QR1016, QR1018, QR1020, QR1021, QR1022, QR1025, QR1026, QR1028, QR1029, QR1030, QR1032, QR1035, QR1036, QR1038, QR1040, QR1042, QR1045, QR1046, QR1048, QR1050, QR1051, QR1051W, QR1051GL, QZ1010, QZ1012, QZ1015, QZ1016, QZ1018, QZ1020, QZ1021, QZ1022, QZ1025, QZ1026, QZ1028, QZ1029, QZ1030, QZ1032, QZ1035, QZ1036, QZ1038, QZ1040, QZ1042, QZ1045, QZ1046, QZ1048, QZ1050, QZ1051, QZ1052, QZ1054, QZ1056, QZ1058, QZ1060, QZ1090, QZ1090W, QZ1090GL, QZ1095, QZ1095W, QZ1095GL, QZ1197, QZ1197W, QZ1197GL, QZ1330, QZ1330W, QZ1330GL, QZ1410, QZ1410W, QZ1410GL, QA1010, QA1010W, QA1010GL, QA1051, QA1051W, QA1051GL, QA1036, QA1036W, QA1036GL, QA1095, QA1095W, QA1095GL, QA1330, QA1330W, QA1330GL, QA1410, QA1410W, QA1410GL, QA1412, QZ1416, QZ1418, QZ1420, QZ1412GL, QZ1416GL, QZ1418GL, QZ1420GL, QM1010, QM1010W, QM1010GL, QM1012, QM1013, QM1015, QM1016, QM1018, QM1020, QM1021, QM1022, QM1025, QM1026, QM1028, QM1029, QM1030, QM1036, QM1036W, QM1036GL, QM1038, QM1040, QM1042, QM1051, QM1051W, QM1051GL, QM1036, QM1036GL, QM1095, QM1095W, QM1095GL, QM1197, QM1191W, QM1197GL, QM1330, QM1330W, QM1330GL, QM1410, QM1410W, QM1410GL, QM1412, QM1416, QM109GL, QA1295, QA1295W, QA1295GL, QZ1295, QZ1295W, QM1295GL, QM1295, QM1295W, QM1295GL, QM706, QM706GL, QM806GL, QM7082, QM8082, QM8017, QM1066, QM1067, QM1082, QM1016, QM8016, QM066GL, QM806G3, QM106G3, QM706G3, QM8086GL, QM106GL, QM10T10GL, HT12</p>	
Test Model:	QZ1095W	
Model Different.:	All Model are same in all respects. Only the model names are different for different market requirement. They are identical in structure, circuit, circuit, screen printing, bit number, RF module, antenna, etc.	
Sample ID	N/A	
Sample(s) Status:	Engineer sample	
Product Description	IEEE 802.11 WLAN Mode Supported	<input checked="" type="checkbox"/> 802.11a/n (20MHz channel bandwidth) <input checked="" type="checkbox"/> 802.11n (40MHz channel bandwidth)
	Data Rate	802.11a:6/9/12/18/24/36/48/54Mbps 802.11n(HT20):MCS0-MCS7 802.11n(HT40):MCS0-MCS9
	Modulation	OFDM with BPSK/QPSK/16QAM/64QAM for 802.11a/n

	Operating Frequency Range	<input checked="" type="checkbox"/> 5180-5240MHz for 802.11a/n(HT20); <input checked="" type="checkbox"/> 5190-5230MHz for 802.11n(HT40);
	Number of Channels	<input checked="" type="checkbox"/> 4 channels for 802.11 n40 in the 5180-5240 MHz band <input checked="" type="checkbox"/> 2 channels for 802.11 n40 in the 5190-5230 MHz band
Channel List	Please refer to the Note 2.	
Antenna Type:	FPC antenna	
Antenna gain:	1.27dBi	
PMN:	N/A	
HVIN/Hardware version:	V1.0	
FVIN/Software version:	V1.0	
Power supply:	DC 5V from USB port; Battery: DC 3.8V, 8000mAh	

Frequency Channel							
Channel	Frequency (MHz)	Channel	Frequency (MHz)	Channel	Frequency (MHz)	Channel	Frequency (MHz)
36	5180	44	5220	38	5190	40	5200
46	5230	48	5240				

3.2 DESCRIPTION OF TEST MODES

Transmitting mode	Keep the EUT in continuously transmitting mode
Remark: During the test, the duty cycle >98%, the test voltage was tuned from 85% to 115% of the nominal rated supply voltage, and found that the worst case was under the nominal rated supply condition. So the report just shows that condition's data.	

Pretest Mode	Description
Mode 1	802.11a/n 20 CH36/ CH40/ CH 48, 802.11n 40 CH38/ CH46
Mode 2	Link Mode

Conducted Emission	
Final Test Mode	Description
Mode 1	Link Mode

For Radiated Emission	
Final Test Mode	Description
Mode 1	802.11a/n 20 CH36/ CH40/ CH 48, 802.11n 40 CH38/ CH46

Note:

(1) The measurements are performed at all Bit Rate of Transmitter, the worst data was reported.

Test Software	Realtek Test Tool
Power level setup	<20dBm

3.3 BLOCK DIGRAM SHOWING THE CONFIGURATION OF SYSTEM TESTED

Conducted Emission

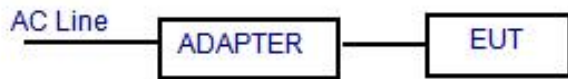

Radiated Emission

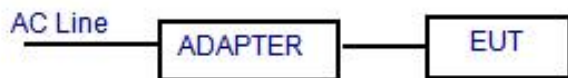

Conducted Spurious



3.4 DESCRIPTION OF SUPPORT UNITS

The EUT has been tested as an independent unit together with other necessary accessories or support units. The following support units or accessories were used to form a representative test configuration during the tests.

Item	Equipment	Mfr/Brand	Model/Type No.	Series No.	Note
/	ADAPTER	/	ADS-5002000C	/	DC5V/2A

Item	Shielded Type	Ferrite Core	Length	Note

Note:

- (1) The support equipment was authorized by Declaration of Confirmation.
- (2) For detachable type I/O cable should be specified the length in cm in 『Length』 column.

3.5 EQUIPMENTS LIST FOR ALL TEST ITEMS

Radiation Test equipment

Item	Equipment	Manufacturer	Type No.	Serial No.	Last calibration	Calibrated until
1	Communication Tester	Rohde & Schwarz	CMW500	100358 Fireware: 4.43 SP4	Oct. 22, 2023	Oct. 21, 2024
2	Spectrum Analyzer	KEYSIGHT	9020A	MY55370835	Oct. 22, 2023	Oct. 21, 2024
3	Test Receiver	R&S	ESC17	US47140102 Fireware: 4.42 SP3	Oct. 22, 2023	Oct. 21, 2024
4	Signal Generator	HP	83630B	3844A01028	Oct. 22, 2023	Oct. 21, 2024
5	Signal Generator	IFR	2023A	202307/242	Oct. 22, 2023	Oct. 21, 2024
6	Amplifier	Agilent	8449B	4035A00116	Oct. 22, 2023	Oct. 21, 2024
7	Amplifier	HP	8447E	2945A02770	Oct. 22, 2023	Oct. 21, 2024
8	Broadband Antenna	SCHAFFNER	2774	2774	Feb.28,2022	Feb.27,2025
9	Biconical and log periodic antennas	ELECTRO-METRICS	EM-6917B-1	171	Feb.28,2022	Feb.27,2025
10	Horn Antenna	R&S	HF906	100253	Feb.28,2022	Feb.27,2025
11	Horn Antenna	Schwarzbeck	BBHA9170	00814	Feb.28,2022	Feb.27,2025
12	Horn Antenna	EM	EM-6961	6462	Feb.28,2022	Feb.27,2025
13	3m Semi-Anechoic Chamber	Chengyu Electron	9 (L)*6 (W)* 6 (H)	BSL086	Feb.28,2022	Feb.27,2025
14	Loop Antenna	ZHINAN	ZN30900C	20073	Feb.28,2022	Feb.27,2025
15	power meter	DARE	RPR3006W	15I00041SNO0	Oct.27,2023	Oct.26,2024
16	RF Control Unit	MWRFtest	Mw100	-	Oct.27,2023	Oct.26,2024
17	Test software	MWRFtest	V8310	-	-	-
18	Turntable	MF	MF-7802BS	N/A	\	\

Conduction Test equipment

Item	Kind of Equipment	Manufacturer	Type No.	Serial No.	Last calibration	Calibrated until
1	LISN	R&S	ENV216	101471	Oct.27,2023	Oct.26,2024
2	LISN	CYBERTEK	EM5040A	E1850400149	Oct.27,2023	Oct.26,2024
3	Test Cable	N/A	C01	N/A	Oct.27,2023	Oct.26,2024
4	Test Cable	N/A	C02	N/A	Oct.27,2023	Oct.26,2024
5	EMI Test Receiver	R&S	ESC13	101393	Oct.27,2023	Oct.26,2024

6	Absorbing Clamp	DZ	ZN23201	15034	Oct.27,2023	Oct.26,2024
7	EMC Software	Frad	EZ-EMC	Ver.EMC-CON 3A1.1	\	\

RF Conduction Test equipment

Item	Kind of Equipment	Manufacturer	Type No.	Serial No.	Last calibration	Calibrated until
1	Spectrum Analyzer (9kHz-26.5GHz)	KEYSIGHT	9020A	MY55370835	Oct.27,2023	Oct.26,2024
2	MWRF Power Meter Test system	MW	MW100-RPCB	N/A	Oct.27,2023	Oct.26,2024
3	D.C. Power Supply	LongWei	TPR-6405D	N/A	\	\
4	RF Software	MW	MTS8310	V2.0.0.0	\	\

4.EMC EMISSION TEST

4.1 CONDUCTED EMISSION MEASUREMENT

Test Requirement:	FCC Part15 C Section 15.207
Test Method:	ANSI C63.10:2013
Test Frequency Range:	150KHz to 30MHz
Receiver setup:	RBW=9KHz, VBW=30KHz, Sweep time=auto

4.1.1 POWER LINE CONDUCTED EMISSION Limits

FREQUENCY (MHz)	Limit (dBuV)		Standard
	Quasi-peak	Average	
0.15 -0.5	66 - 56 *	56 - 46 *	FCC
0.50 -5.0	56.00	46.00	FCC
5.0 -30.0	60.00	50.00	FCC

Note:

(1) *Decreases with the logarithm of the frequency.

4.1.2 TEST PROCEDURE

- a. The EUT was placed 0.8 meters from the horizontal ground plane with EUT being connected to the power mains through a line impedance stabilization network (LISN). All other support equipments powered from additional LISN(s). The LISN provide 50 Ohm/ 50uH of coupling impedance for the measuring instrument.
- b. Interconnecting cables that hang closer than 40 cm to the ground plane shall be folded back and forth in the center forming a bundle 30 to 40 cm long.
- c. I/O cables that are not connected to a peripheral shall be bundled in the center. The end of the cable may be terminated, if required, using the correct terminating impedance. The overall length shall not exceed 1 m.
- d. LISN at least 80 cm from nearest part of EUT chassis.
- e. For the actual test configuration, please refer to the related Item –EUT Test Photos.

4.1.3 DEVIATION FROM TEST STANDARD

No deviation

4.1.4 TEST SETUP

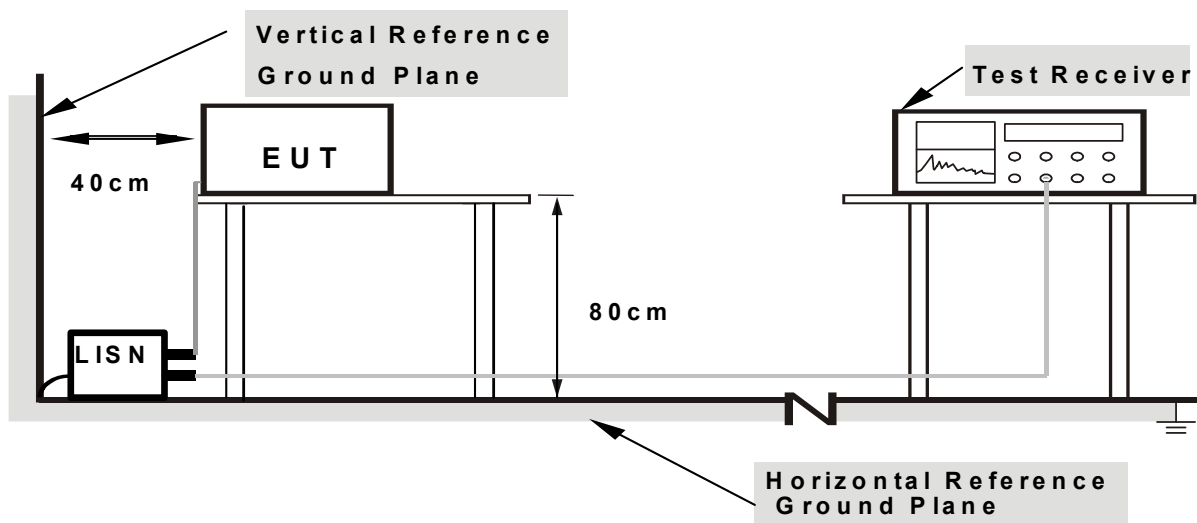

- Note: 1.Support units were connected to second LISN .**
2.Both of LISNs (AMN) are 80 cm from EUT and at least 80 from other units and other metal planes

4.1.5 EUT OPERATING CONDITIONS

The EUT was configured for testing in a typical fashion (as a customer would normally use it). The EUT has been programmed to continuously transmit during test. This operating condition was tested and used to collect the included data.

We pretest AC 120V and AC 230V, the worst voltage was AC 120V and the data recording in the report.

4.1.6 TEST RESULT (Worst case 802.11a 5180MHz)

Temperature:	26°C	Relative Humidity:	54%
Pressure:	101kPa	Phase :	L
Test Voltage :	AC 120V/60Hz		

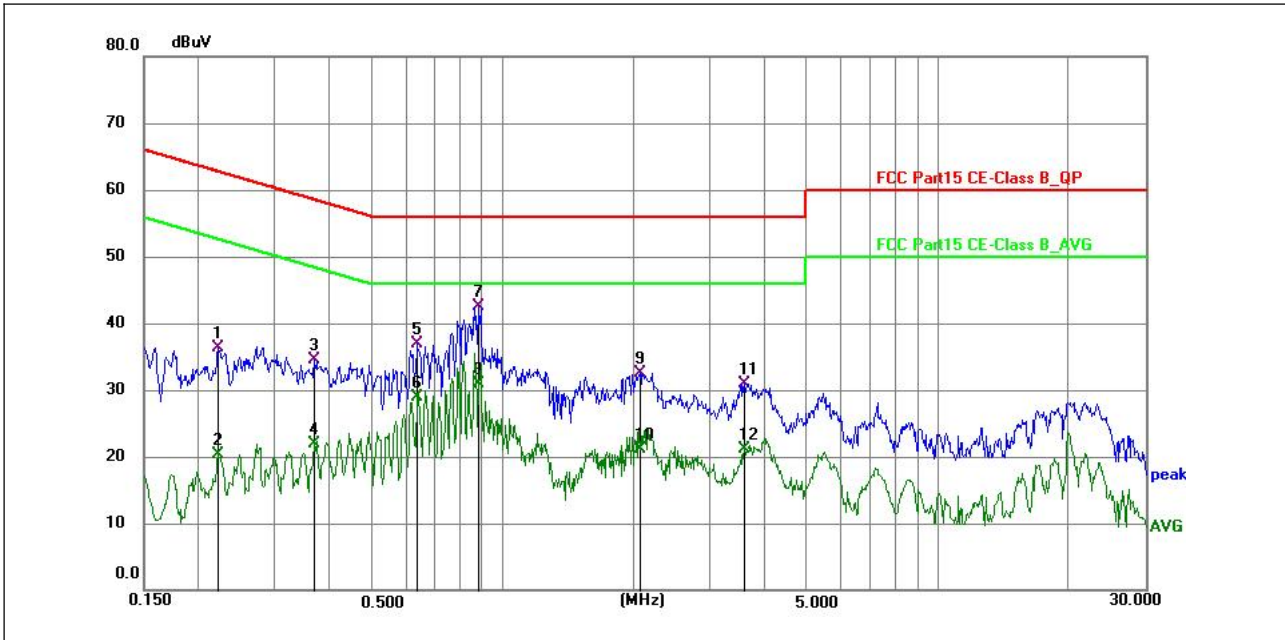

No.	Frequency (MHz)	Reading (dBuV)	Factor (dB)	Level (dBuV)	Limit (dBuV)	Margin (dB)	Detector	P/F
1	0.2220	26.52	9.70	36.22	62.74	-26.52	QP	P
2	0.2220	10.63	9.70	20.33	52.74	-32.41	AVG	P
3	0.3689	24.80	9.65	34.45	58.53	-24.08	QP	P
4	0.3689	12.35	9.65	22.00	48.53	-26.53	AVG	P
5	0.6360	27.21	9.69	36.90	56.00	-19.10	QP	P
6	0.6360	19.13	9.69	28.82	46.00	-17.18	AVG	P
7 *	0.8830	32.92	9.60	42.52	56.00	-13.48	QP	P
8	0.8830	21.31	9.60	30.91	46.00	-15.09	AVG	P
9	2.0670	22.80	9.71	32.51	56.00	-23.49	QP	P
10	2.0670	11.44	9.71	21.15	46.00	-24.85	AVG	P
11	3.5924	21.40	9.57	30.97	56.00	-25.03	QP	P
12	3.5924	11.53	9.57	21.10	46.00	-24.90	AVG	P

Notes:

1. An initial pre-scan was performed on the line and neutral lines with peak detector.
2. Quasi-Peak and Average measurement were performed at the frequencies with maximized peak emission.
3. Measurement Level = Reading level + Correct Factor

Temperature:	26°C	Relative Humidity:	54%
Pressure:	101kPa	Phase :	N
Test Voltage :	AC 120V/60Hz		

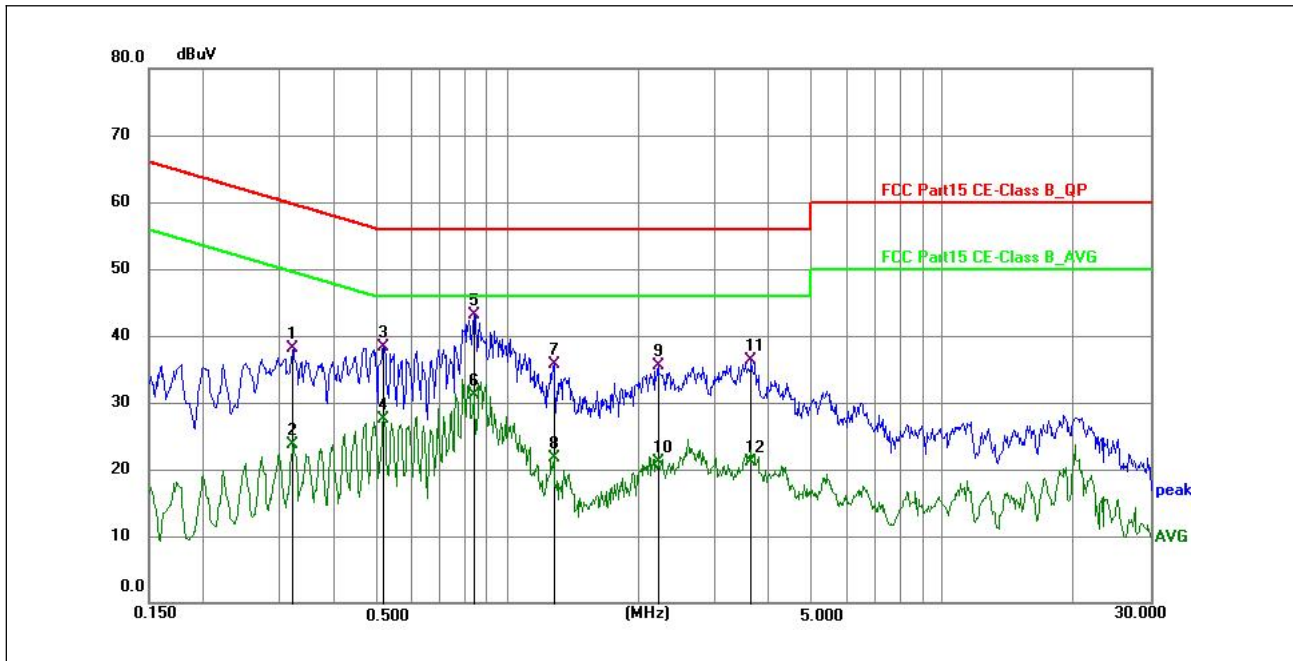

No.	Frequency (MHz)	Reading (dBuV)	Factor (dB)	Level (dBuV)	Limit (dBuV)	Margin (dB)	Detector	P/F
1	0.3209	28.45	9.67	38.12	59.68	-21.56	QP	P
2	0.3209	13.95	9.67	23.62	49.68	-26.06	AVG	P
3	0.5190	28.60	9.63	38.23	56.00	-17.77	QP	P
4	0.5190	17.90	9.63	27.53	46.00	-18.47	AVG	P
5 *	0.8385	33.52	9.63	43.15	56.00	-12.85	QP	P
6	0.8385	21.53	9.63	31.16	46.00	-14.84	AVG	P
7	1.2795	26.13	9.58	35.71	56.00	-20.29	QP	P
8	1.2795	12.13	9.58	21.71	46.00	-24.29	AVG	P
9	2.2155	25.73	9.70	35.43	56.00	-20.57	QP	P
10	2.2155	11.38	9.70	21.08	46.00	-24.92	AVG	P
11	3.6240	26.65	9.57	36.22	56.00	-19.78	QP	P
12	3.6240	11.51	9.57	21.08	46.00	-24.92	AVG	P

Notes:

- 1.An initial pre-scan was performed on the line and neutral lines with peak detector.
- 2.Quasi-Peak and Average measurement were performed at the frequencies with maximized peak emission.
- 3.Measurement Level = Reading level + Correct Factor

4.2 RADIATED EMISSION MEASUREMENT

4.2.1 APPLICABLE STANDARD

According to FCC Part 15.407(d) and 15.209

4.2.2 CONFORMANCE LIMIT

According to FCC Part 15.407(b): radiated emissions which fall in the restricted bands, as defined in §15.205(a), must also comply with the radiated emission limits specified in §15.209(a) (see §15.205(c)).

According to FCC Part 15.205, Restricted bands

MHz	MHz	MHz	GHz
0.090-0.110	16.42-16.423	399.9-410	4.5-5.15
10.495-0.505	16.69475-16.69525	608-614	5.35-5.46
2.1735-2.1905	16.80425-16.80475	960-1240	7.25-7.75
4.125-4.128	25.5-25.67	1300-1427	8.025-8.5
4.17725-4.17775	37.5-38.25	1435-1626.5	9.0-9.2
4.20725-4.20775	73-74.6	1645.5-1646.5	9.3-9.5
6.215-6.218	74.8-75.2	1660-1710	10.6-12.7
6.26775-6.26825	123-138	2200-2300	14.47-14.5
8.291-8.294	149.9-150.05	2310-2390	15.35-16.2
8.362-8.366	156.52475-156.52525	2483.5-2500	17.7-21.4
8.37625-8.38675	156.7-156.9	2690-2900	22.01-23.12
8.41425-8.41475	162.0125-167.17	3260-3267	23.6-24.0
12.29-12.293	167.72-173.2	3332-3339	31.2-31.8
12.51975-12.52025	240-285	3345.8-3358	36.43-36.5
12.57675-12.57725	322-335.4	3600-4400	(2)
13.36-13.41			

20dBc in any 100 kHz bandwidth outside the operating frequency band. In case the emission fall within the restricted band specified on 15.205(a), then the 15.209(a) limit in the table below has to be followed.

Restricted Frequency(MHz)	Field Strength (μV/m)	Field Strength (dBμV/m)	Measurement Distance
0.009~0.490	2400/F(KHz)	20 log (uV/m)	300
0.490~1.705	2400/F(KHz)	20 log (uV/m)	30
1.705~30.0	30	29.5	30
30-88	100	40	3
88-216	150	43.5	3
216-960	200	46	3
Above 960	500	54	3

Limits of Radiated Emission Measurement(Above 1000MHz)

Frequency(MHz)	Class B (dBuV/m) (at 3M)	
	PEAK	AVERAGE
Above 1000	74	54

Remark :1. Emission level in dBuV/m=20 log (uV/m)

2. Measurement was performed at an antenna to the closed point of EUT distance of meters.

3. Distance extrapolation factor =40log(Specific distance/ test distance)(dB);

Limit line=Specific limits(dBuV) + distance extrapolation factor.

For FCC Band Edge Limit:

(1) For transmitters operating in the 5.15-5.25 GHz band: All emissions outside of the 5.15-5.35 GHz band shall not exceed an e.i.r.p. of -27 dBm/MHz.

(2) For transmitters operating in the 5.25-5.35 GHz band: All emissions outside of the 5.15-5.35 GHz band shall not exceed an e.i.r.p. of -27 dBm/MHz.

(3) For transmitters operating in the 5.47-5.725 GHz band: All emissions outside of the 5.47-5.725 GHz band shall not exceed an e.i.r.p. of -27 dBm/MHz.

(4) For transmitters operating in the 5.725-5.85 GHz band:

(i) All emissions shall be limited to a level of -27 dBm/MHz at 75 MHz or more above or below the band edge increasing linearly to 10 dBm/MHz at 25 MHz above or below the band edge, and from 25 MHz above or below the band edge increasing linearly to a level of 15.6 dBm/MHz at 5 MHz above or below the band edge, and from 5 MHz above or below the band edge increasing linearly to a level of 27 dBm/MHz at the band edge.

(ii) Devices certified before March 2, 2017 with antenna gain greater than 10 dBi may demonstrate compliance with the emission limits in § 15.247(d), but manufacturing, marketing and importing of devices certified under this alternative must cease by March 2, 2018. Devices certified before March 2, 2018 with antenna gain of 10 dBi or less may demonstrate compliance with the emission limits in § 15.247(d), but manufacturing, marketing and importing of devices certified under this alternative must cease before March 2, 2020.

(5) The emission measurements shall be performed using a minimum resolution bandwidth of 1 MHz. A lower resolution bandwidth may be employed near the band edge, when necessary, provided the measured energy is integrated to show the total power over 1 MHz.

(6) Unwanted emissions below 1 GHz must comply with the general field strength limits set forth in § 15.209.

Further, any U-NII devices using an AC power line are required to comply also with the conducted limits set forth in § 15.207.

(7) The provisions of § 15.205 apply to intentional radiators operating under this section.

4.2.3 MEASURING INSTRUMENTS

The Measuring equipment is listed in the section 6.3 of this test report.

4.2.4 TEST CONFIGURATION

1. For radiated emissions below 30MHz

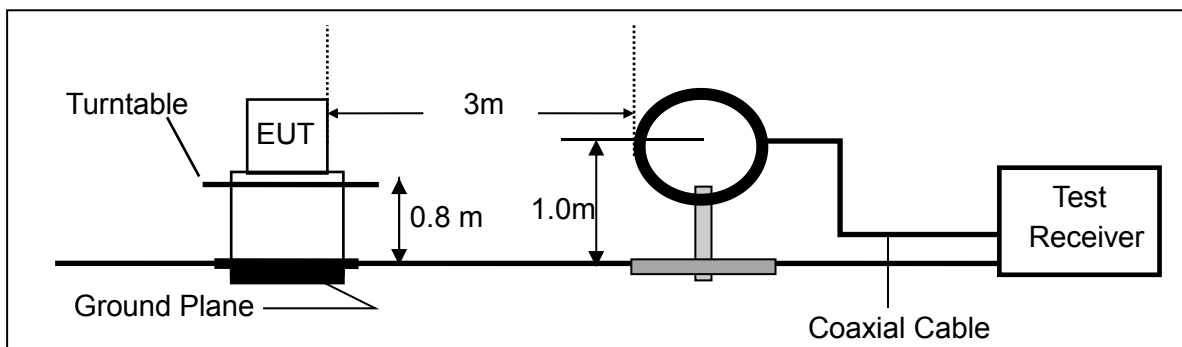

2. For radiated emissions from 30MHz to 1000MHz

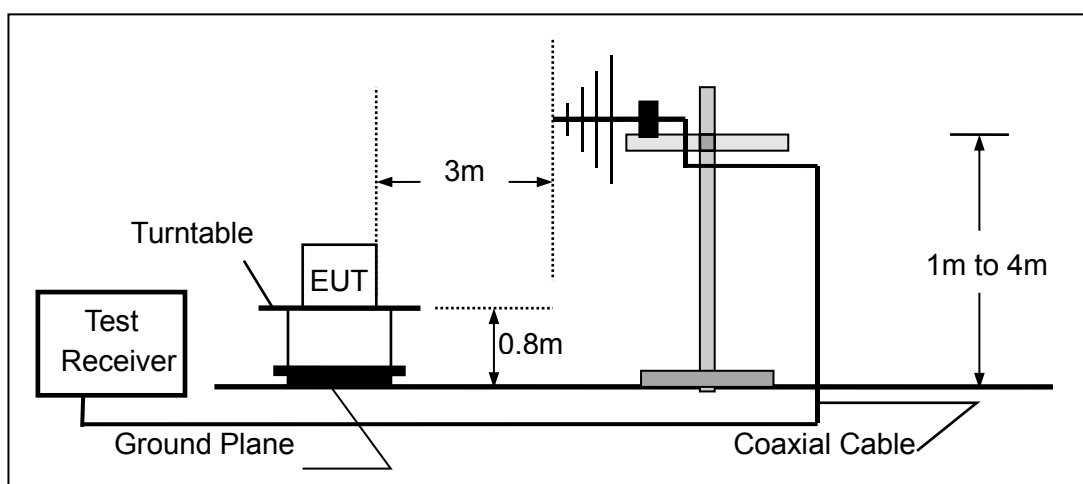

3. Radiated Emission Test-Up Frequency Above 1GHz

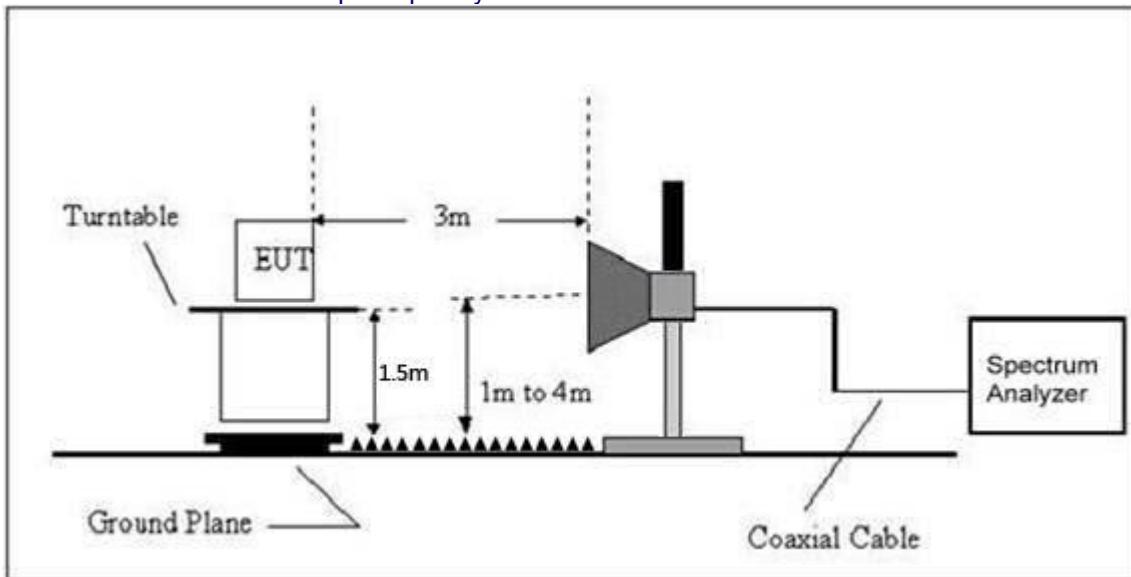

4.2.5 TEST PROCEDURE

The test site semi-anechoic chamber has met the requirement of NSA tolerance 4 dB according to the standards: ANSI C63.10-2013. The test distance is 3m. The setup is according to the requirements in Section 13.1.4.1 of ANSI C63.10-2013 and CAN/CSA-CEI/IEC CISPR 22.

This test is required for any spurious emission that falls in a Restricted Band, as defined in Section 15.205. It must be performed with the highest gain of each type of antenna proposed for use with the EUT.

Use the following spectrum analyzer settings:

Spectrum Parameter	Setting
Attenuation	Auto
Start Frequency	1000 MHz
Stop Frequency	10th carrier harmonic
RB / VB (emission in restricted band)	1 MHz / 1 MHz for Peak, 1 MHz / 10Hz for Average

Receiver Parameter	Setting
Attenuation	Auto
Start ~ Stop Frequency	9kHz~150kHz / RB 200Hz for QP
Start ~ Stop Frequency	150kHz~30MHz / RB 9kHz for QP
Start ~ Stop Frequency	30MHz~1000MHz / RB 120kHz for QP

- a. The measuring distance of at 3 m shall be used for measurements at frequency up to 1GHz. For frequencies above 1GHz, any suitable measuring distance may be used.
- b. The EUT was placed on the top of a rotating table 0.8 m for below 1GHz and 1.5m for above 1GHz the ground at a 3 meter. The table was rotated 360 degrees to determine the position of the highest radiation.
- c. The height of the equipment or of the substitution antenna shall be 0.8 m for below 1GHz and 1.5m for above 1GHz; the height of the test antenna shall vary between 1 m to 4 m. Both horizontal and vertical polarizations of the antenna are set to make the measurement.
- d. The initial step in collecting conducted emission data is a spectrum analyzer peak detector mode pre-scanning the measurement frequency range. Significant peaks are then marked and then Quasi Peak detector mode re-measured.
- e. If the Peak Mode measured value compliance with and lower than Quasi Peak Mode Limit, the EUT shall be deemed to meet QP Limits and then no additional QP Mode measurement performed.
- f. For the actual test configuration, please refer to the related Item –EUT Test Photos.

Note:

Both horizontal and vertical antenna polarities were tested and performed pretest to three orthogonal axis. The worst case emissions were reported

During the radiated emission test, the Spectrum Analyzer was set with the following configurations:

Frequency Band (MHz)	Function	Resolution bandwidth	Video Bandwidth
30 to 1000	QP	120 kHz	300 kHz
Above 1000	Peak	1 MHz	1 MHz
	Average	1 MHz	10 Hz

Note: for the frequency ranges below 30 MHz, a narrower RBW is used for these ranges but the measured value should add a RBW correction factor (RBWCF) where $RBWCF [dB] = 10 \cdot \lg(100 [kHz]/\text{narrower RBW [kHz]})$. , the narrower RBW is 1 kHz and RBWCF is 20 dB for the frequency 9 kHz to 150 kHz, and the narrower RBW is 10 kHz and RBWCF is 10 dB for the frequency 150 kHz to 30 MHz.

4.2.6 TEST RESULT

Between 9KHz – 30MHz

The emission from 9 kHz to 30MHz was pre-tested and found the result was 20dB lower than the limit, and according to 15.31(o) & RSS-Gen 6.13, the test result no need to reported.

Between 30MHz – 1GHz

Temperature:	26°C	Relative Humidity:	54%
Pressure:	101 kPa	Polarization:	Horizontal
Test Voltage:	AC 120V/60Hz		

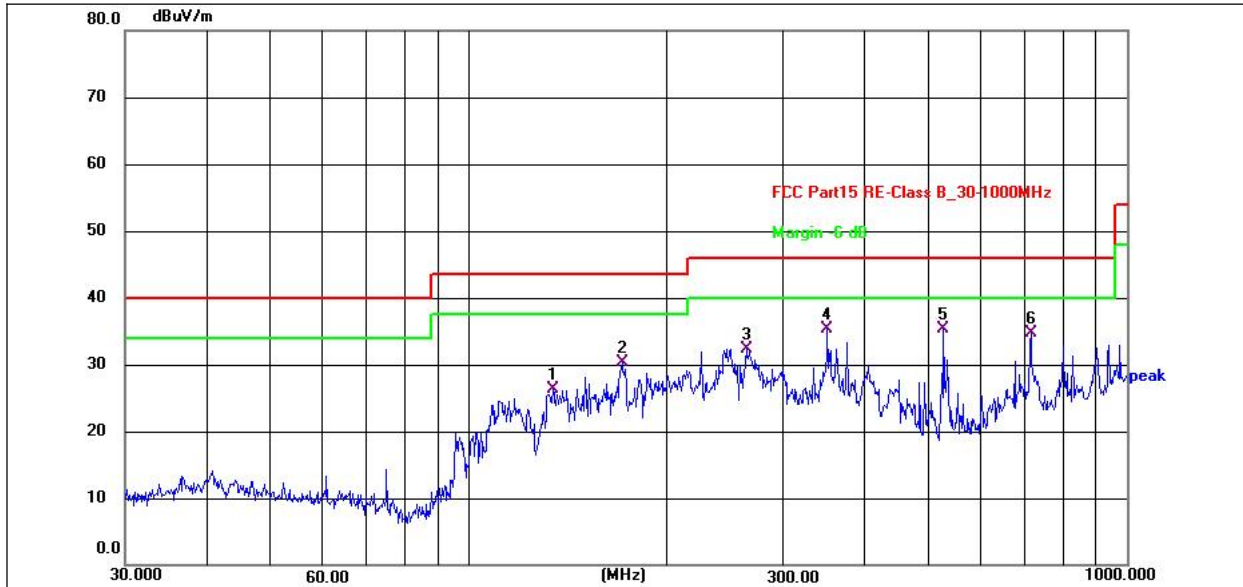

No.	Frequency (MHz)	Reading (dBuV)	Factor (dB/m)	Level (dBuV/m)	Limit (dBuV/m)	Margin (dB)	Detector
1	134.0880	43.63	-17.29	26.34	43.50	-17.16	QP
2	170.7923	46.82	-16.53	30.29	43.50	-13.21	QP
3	263.8190	49.80	-17.45	32.35	46.00	-13.65	QP
4	350.4766	50.34	-15.05	35.29	46.00	-10.71	QP
5 *	526.3967	45.66	-10.27	35.39	46.00	-10.61	QP
6	714.1733	41.14	-6.46	34.68	46.00	-11.32	QP

Temperature:	26°C	Relative Humidity:	54%
Pressure:	101kPa	Polarization:	Vertical
Test Voltage:	AC 120V/60Hz		

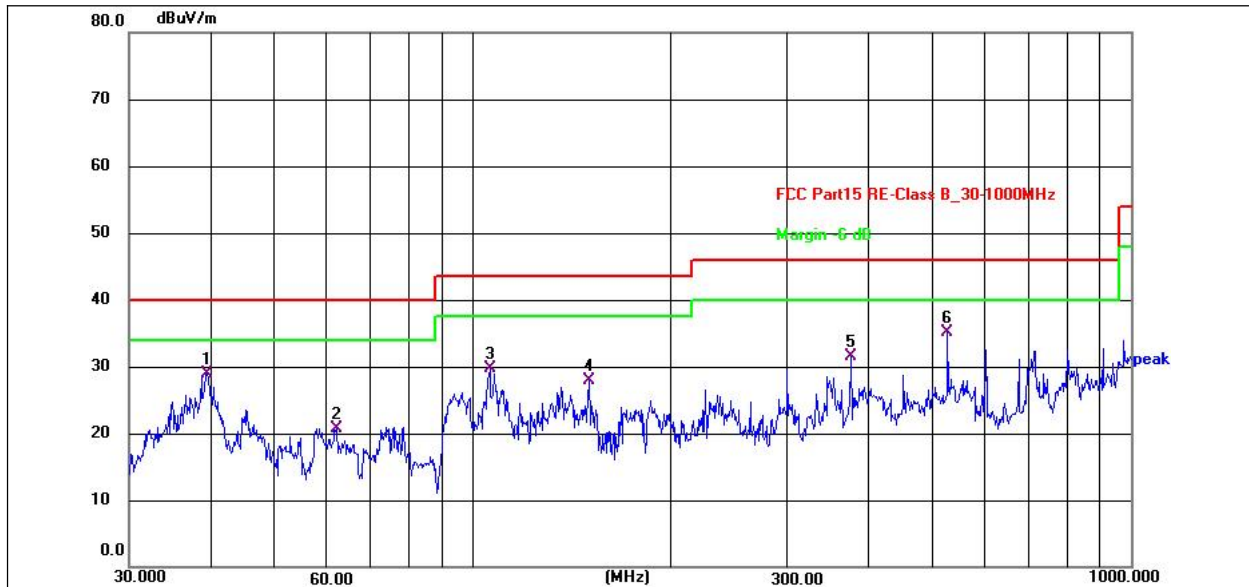

No.	Frequency (MHz)	Reading (dBuV)	Factor (dB/m)	Level (dBuV/m)	Limit (dBuV/m)	Margin (dB)	Detector
1	39.4371	44.72	-15.78	28.94	40.00	-11.06	QP
2	61.9950	38.26	-17.50	20.76	40.00	-19.24	QP
3	106.0126	49.05	-19.42	29.63	43.50	-13.87	QP
4	150.0107	43.64	-15.78	27.86	43.50	-15.64	QP
5	375.9384	45.52	-14.11	31.41	46.00	-14.59	QP
6 *	526.3967	45.46	-10.27	35.19	46.00	-10.81	QP

Remarks:

1. Final Level = Receiver Read level + Antenna Factor + Cable Loss – Preamplifier Factor
2. The emission levels of other frequencies are very lower than the limit and not show in test report.
3. The test data shows only the worst case 802.11n20 5180mode

Between 1GHz – 40GHz

Temperature:	26°C	Relative Humidity:	54%
Pressure:	1010 hPa	Test Voltage :	DC 3.8V
Test Mode :	5.2G TX- 802.11a/n20(Worst case)		

802.11a

Polar (H/V)	Frequency	Meter Reading	Pre-amplifier	Cable Loss	Antenna Factor	Emission Level	Limits	Margin	Detect or Type
	(MHz)	(dBuV)	(dB)	(dB)	(dB)	(dBuV/m)	(dBuV/m)	(dB)	
Low Channel:5180MHz									
V	10360.00	52.20	30.55	5.77	24.66	49.35	74.00	-24.65	PK
V	10360.00	43.46	30.55	5.77	24.66	43.34	54.00	-10.66	AV
V	15540.00	53.20	30.33	6.32	24.55	53.74	74.00	-20.26	PK
V	15540.00	43.41	30.33	6.32	24.55	43.95	54.00	-10.05	AV
V	20720.00	54.01	30.85	7.45	24.69	55.30	74.00	-18.70	PK
V	20720.00	43.51	30.85	7.45	24.69	44.80	54.00	-9.20	AV
V	25900.00	52.95	31.02	8.99	25.57	56.49	74.00	-17.51	PK
V	25900.00	43.64	31.02	8.99	25.57	47.18	54.00	-6.82	AV
H	10360.00	54.40	30.55	5.77	24.66	54.28	74.00	-19.72	PK
H	10360.00	43.29	30.55	5.77	24.66	43.17	54.00	-10.83	AV
H	15540.00	51.73	30.33	6.32	24.55	52.27	74.00	-21.73	PK
H	15540.00	43.03	30.33	6.32	24.55	43.57	54.00	-10.43	AV
H	20720.00	51.13	30.85	7.45	24.69	52.42	74.00	-21.58	PK
H	20720.00	43.12	30.85	7.45	24.69	44.41	54.00	-9.59	AV
H	25900.00	54.20	31.02	8.99	25.57	57.74	74.00	-16.26	PK
H	25900.00	43.59	31.02	8.99	25.57	47.13	54.00	-6.87	AV

Polar (H/V)	Frequency	Meter Reading	Pre-amplifier	Cable Loss	Antenna Factor	Emission Level	Limits	Margin	Detect or Type
	(MHz)	(dBuV)	(dB)	(dB)	(dB)	(dBuV/m)	(dBuV/m)	(dB)	
Middle Channel:5200MHz									
V	10400.00	51.15	30.55	5.77	24.66	51.03	74.00	-22.97	PK
V	10400.00	43.91	30.55	5.77	24.66	43.79	54.00	-10.21	AV
V	15600.00	54.86	30.33	6.32	24.55	55.40	74.00	-18.60	PK
V	15600.00	43.88	30.33	6.32	24.55	44.42	54.00	-9.58	AV
V	20800.00	51.03	30.85	7.45	24.69	52.32	74.00	-21.68	PK
V	20800.00	43.77	30.85	7.45	24.69	45.06	54.00	-8.94	AV
V	26000.00	53.49	31.02	8.99	25.57	57.03	74.00	-16.97	PK
V	26000.00	43.66	31.02	8.99	25.57	47.20	54.00	-6.80	AV
H	10400.00	50.04	30.55	5.77	24.66	49.92	74.00	-24.08	PK
H	10400.00	43.82	30.55	5.77	24.66	43.70	54.00	-10.30	AV
H	15600.00	52.63	30.33	6.32	24.55	53.17	74.00	-20.83	PK
H	15600.00	43.56	30.33	6.32	24.55	44.10	54.00	-9.90	AV
H	20800.00	53.16	30.85	7.45	24.69	54.45	74.00	-19.55	PK
H	20800.00	43.99	30.85	7.45	24.69	45.28	54.00	-8.72	AV
H	26000.00	52.67	31.02	8.99	25.57	56.21	74.00	-17.79	PK
H	26000.00	43.19	31.02	8.99	25.57	46.73	54.00	-7.27	AV

Polar (H/V)	Frequency	Meter Reading	Pre-ampli fier	Cable Loss	Antenna Factor	Emission Level	Limits	Margin	Detect or Type
	(MHz)	(dBuV)	(dB)	(dB)	(dB)	(dBuV/m)	(dBuV/ m)	(dB)	
High Channel:5240MHz									
V	10480.00	50.28	30.55	5.77	24.66	50.16	74.00	-23.84	PK
V	10480.00	43.67	30.55	5.77	24.66	43.55	54.00	-10.45	AV
V	15720.00	51.23	30.33	6.32	24.55	51.77	74.00	-22.23	PK
V	15720.00	43.29	30.33	6.32	24.55	43.83	54.00	-10.17	AV
V	20960.00	53.56	30.85	7.45	24.69	54.85	74.00	-19.15	PK
V	20960.00	43.03	30.85	7.45	24.69	44.32	54.00	-9.68	AV
V	26200.00	52.71	31.02	8.99	25.57	56.25	74.00	-17.75	PK
V	26200.00	43.80	31.02	8.99	25.57	47.34	54.00	-6.66	AV
H	10480.00	54.38	30.55	5.77	24.66	54.26	74.00	-19.74	PK
H	10480.00	43.54	30.55	5.77	24.66	43.42	54.00	-10.58	AV
H	15720.00	52.01	30.33	6.32	24.55	52.55	74.00	-21.45	PK
H	15720.00	43.14	30.33	6.32	24.55	43.68	54.00	-10.32	AV
H	20960.00	51.85	30.85	7.45	24.69	53.14	74.00	-20.86	PK
H	20960.00	43.06	30.85	7.45	24.69	44.35	54.00	-9.65	AV
H	26200.00	51.21	31.02	8.99	25.57	54.75	74.00	-19.25	PK
H	26200.00	43.86	31.02	8.99	25.57	47.40	54.00	-6.60	AV

802.11n20

Polar (H/V)	Frequency	Meter Reading	Pre-ampl ifier	Cable Loss	Antenna Factor	Emission Level	Limits	Margin	Detect or Type
	(MHz)	(dBuV)	(dB)	(dB)	(dB)	(dBuV/m)	(dBuV/ m)	(dB)	
Low Channel:5180MHz									
V	10360.00	52.66	30.55	5.77	24.66	52.54	74.00	-21.46	PK
V	10360.00	43.24	30.55	5.77	24.66	43.12	54.00	-10.88	AV
V	15540.00	52.87	30.33	6.32	24.55	53.41	74.00	-20.59	PK
V	15540.00	43.58	30.33	6.32	24.55	44.12	54.00	-9.88	AV
V	20720.00	52.35	30.85	7.45	24.69	53.64	74.00	-20.36	PK
V	20720.00	43.90	30.85	7.45	24.69	45.19	54.00	-8.81	AV
V	25900.00	54.77	31.02	8.99	25.57	58.31	74.00	-15.69	PK
V	25900.00	43.25	31.02	8.99	25.57	46.79	54.00	-7.21	AV
H	10360.00	52.57	30.55	5.77	24.66	52.45	74.00	-21.55	PK
H	10360.00	43.95	30.55	5.77	24.66	43.83	54.00	-10.17	AV
H	15540.00	52.71	30.33	6.32	24.55	53.25	74.00	-20.75	PK
H	15540.00	43.32	30.33	6.32	24.55	43.86	54.00	-10.14	AV
H	20720.00	52.72	30.85	7.45	24.69	54.01	74.00	-19.99	PK
H	20720.00	43.59	30.85	7.45	24.69	44.88	54.00	-9.12	AV
H	25900.00	52.64	31.02	8.99	25.57	56.18	74.00	-17.82	PK
H	25900.00	43.36	31.02	8.99	25.57	46.90	54.00	-7.10	AV

Polar (H/V)	Frequency	Meter Reading	Pre-ampl ifier	Cable Loss	Antenna Factor	Emission Level	Limits	Margin	Detect or Type
	(MHz)	(dBuV)	(dB)	(dB)	(dB)	(dBuV/m)	(dBuV/ m)	(dB)	
Middle Channel:5200MHz									
V	10400.00	50.18	30.55	5.77	24.66	50.06	74.00	-23.94	PK
V	10400.00	43.95	30.55	5.77	24.66	43.83	54.00	-10.17	AV
V	15600.00	52.72	30.33	6.32	24.55	53.26	74.00	-20.74	PK
V	15600.00	43.19	30.33	6.32	24.55	43.73	54.00	-10.27	AV
V	20800.00	51.27	30.85	7.45	24.69	52.56	74.00	-21.44	PK
V	20800.00	43.18	30.85	7.45	24.69	44.47	54.00	-9.53	AV
V	26000.00	53.30	31.02	8.99	25.57	56.84	74.00	-17.16	PK
V	26000.00	43.40	31.02	8.99	25.57	46.94	54.00	-7.06	AV
H	10400.00	53.17	30.55	5.77	24.66	53.05	74.00	-20.95	PK
H	10400.00	43.00	30.55	5.77	24.66	42.88	54.00	-11.12	AV
H	15600.00	52.91	30.33	6.32	24.55	53.45	74.00	-20.55	PK
H	15600.00	43.78	30.33	6.32	24.55	44.32	54.00	-9.68	AV
H	20800.00	54.22	30.85	7.45	24.69	55.51	74.00	-18.49	PK
H	20800.00	43.71	30.85	7.45	24.69	45.00	54.00	-9.00	AV
H	26000.00	52.84	31.02	8.99	25.57	56.38	74.00	-17.62	PK
H	26000.00	43.96	31.02	8.99	25.57	47.50	54.00	-6.50	AV

Polar (H/V)	Frequency	Meter Reading	Pre-ampli fier	Cable Loss	Antenna Factor	Emission Level	Limits	Margin	Detect or Type
	(MHz)	(dBuV)	(dB)	(dB)	(dB)	(dBuV/m)	(dBuV/ m)	(dB)	
High Channel:5240MHz									
V	10480.00	54.23	30.55	5.77	24.66	54.11	74.00	-19.89	PK
V	10480.00	43.78	30.55	5.77	24.66	43.66	54.00	-10.34	AV
V	15720.00	50.99	30.33	6.32	24.55	51.53	74.00	-22.47	PK
V	15720.00	43.76	30.33	6.32	24.55	44.30	54.00	-9.70	AV
V	20960.00	51.19	30.85	7.45	24.69	52.48	74.00	-21.52	PK
V	20960.00	43.08	30.85	7.45	24.69	44.37	54.00	-9.63	AV
V	26200.00	54.42	31.02	8.99	25.57	57.96	74.00	-16.04	PK
V	26200.00	43.83	31.02	8.99	25.57	47.37	54.00	-6.63	AV
H	10480.00	54.52	30.55	5.77	24.66	54.40	74.00	-19.60	PK
H	10480.00	43.26	30.55	5.77	24.66	43.14	54.00	-10.86	AV
H	15720.00	52.86	30.33	6.32	24.55	53.40	74.00	-20.60	PK
H	15720.00	43.96	30.33	6.32	24.55	44.50	54.00	-9.50	AV
H	20960.00	51.71	30.85	7.45	24.69	53.00	74.00	-21.00	PK
H	20960.00	43.53	30.85	7.45	24.69	44.82	54.00	-9.18	AV
H	26200.00	51.03	31.02	8.99	25.57	54.57	74.00	-19.43	PK
H	26200.00	43.07	31.02	8.99	25.57	46.61	54.00	-7.39	AV

Remark:

1. Emission Level = Meter Reading + Antenna Factor + Cable Loss – Pre-amplifier,

Margin= Emission Level - Limit

2. If peak below the average limit, the average emission was no test.

3. The amplitude of spurious emissions which are attenuated by more than 20dB below the permissible value has no need to be reported.

4.-27dBm(EIRP)=68.3dBuV/m(Field strength at 3m), According to the test results of the above table, while fulfill the requirements of out-of-band spurious

5. POWER SPECTRAL DENSITY TEST

5.1 APPLIED PROCEDURES / LIMIT

According to FCC §15.407(3)

Power limits For FCC:

(1) For the band 5.15-5.25 GHz.

(i) For an outdoor access point operating in the band 5.15-5.25 GHz, the maximum power spectral density shall not exceed 17 dBm in any 1 megahertz band. If transmitting antennas of directional gain greater than 6 dBi are used, both the maximum conducted output power and the maximum power spectral density shall be reduced by the amount in dB that the directional gain of the antenna exceeds 6 dBi. The maximum e.i.r.p. at any elevation angle above 30 degrees as measured from the horizon must not exceed 125 mW (21 dBm).

(ii) For an indoor access point operating in the band 5.15-5.25 GHz, the maximum power spectral density shall not exceed 17 dBm in any 1 megahertz band. If transmitting antennas of directional gain greater than 6 dBi are used, both the maximum conducted output power and the maximum power spectral density shall be reduced by the amount in dB that the directional gain of the antenna exceeds 6 dBi.

(iii) For fixed point-to-point access points operating in the band 5.15-5.25 GHz, the maximum power spectral density shall not exceed 17 dBm in any 1 megahertz band. Fixed point-to-point U-NII devices may employ antennas with directional gain up to 23 dBi without any corresponding reduction in the maximum conducted output power or maximum power spectral density. For fixed point-to-point transmitters that employ a directional antenna gain greater than 23 dBi, a 1 dB reduction in maximum conducted output power and maximum power spectral density is required for each 1 dB of antenna gain in excess of 23 dBi. Fixed, point-to-point operations exclude the use of point-to-multipoint systems, omnidirectional applications, and multiple collocated transmitters transmitting the same information. The operator of the U-NII device, or if the equipment is professionally installed, the installer, is responsible for ensuring that systems employing high gain directional antennas are used exclusively for fixed, point-to-point operations.

(iv) For client devices in the 5.15-5.25 GHz band, the maximum power spectral density shall not exceed 11 dBm in any 1 megahertz band. If transmitting antennas of directional gain greater than 6 dBi are used, both the maximum conducted output power and the maximum power spectral density shall be reduced by the amount in dB that the directional gain of the antenna exceeds 6 dBi.

(2) For the 5.25-5.35 GHz and 5.47-5.725 GHz bands, the maximum conducted output power over the frequency bands of operation shall not exceed the lesser of 250 mW or $11 \text{ dBm} + 10 \log B$, where B is the 26 dB emission bandwidth in megahertz. In addition, the maximum power spectral density shall not exceed 11 dBm in any 1 megahertz band. If transmitting antennas of directional gain greater than 6 dBi are used, both the maximum conducted output power and the maximum power spectral density shall be reduced by the amount in dB that the directional gain of the antenna exceeds 6 dBi.

(3) For the band 5.725-5.85 GHz, the maximum conducted output power over the frequency band of operation shall not exceed 1 W. In addition, the maximum power spectral density shall not exceed 30 dBm in any 500-kHz band. If transmitting antennas of directional gain greater than 6 dBi are used, both the maximum conducted output power and the maximum power spectral density shall be reduced by the amount in dB that the directional gain of the antenna exceeds 6 dBi. However, fixed point-to-point U-NII devices operating in this band may employ transmitting antennas with directional gain greater than 6 dBi without any corresponding reduction in transmitter conducted power. Fixed, point-to-point operations exclude the use of point-to-multipoint systems, omnidirectional applications, and multiple collocated transmitters transmitting the same information. The operator of the U-NII device, or if the equipment is professionally installed, the installer, is responsible for ensuring that systems employing high gain directional antennas are used exclusively for fixed, point-to-point operations.

5.2 TEST PROCEDURE

For devices operating in the bands 5.15-5.25 GHz, 5.25-5.35 GHz, and 5.47-5.725 GHz, the above procedures make use of 1 MHz RBW to satisfy directly the 1 MHz reference bandwidth specified in § 15.407(a)(5). For devices operating in the band 5.725-5.85 GHz, the rules specify a measurement bandwidth of 500 kHz. Many spectrum analyzers do not have 500 kHz RBW, thus a narrower RBW may need to be used. The rules permit the use of a RBWs less than 1 MHz, or 500 kHz, “provided that the measured power is integrated over the full reference bandwidth” to show the total power over the specified measurement bandwidth (i.e., 1 MHz, or 500 kHz). If measurements are performed using a reduced resolution bandwidth (< 1 MHz, or < 500 kHz) and integrated over 1 MHz, or 500 KHz bandwidth, the following adjustments to the procedures apply:

- a) Set $RBW \geq 1/T$, where T is defined in section II.B.I.a).
- b) Set $VBW \geq 3 RBW$.
- c) If measurement bandwidth of Maximum PSD is specified in 500 kHz, add $10\log(500\text{kHz}/RBW)$ to the measured result, whereas RBW (< 500 KHz) is the reduced resolution bandwidth of the spectrum analyzer set during measurement.
- d) If measurement bandwidth of Maximum PSD is specified in 1 MHz, add $10\log(1\text{MHz}/RBW)$ to the measured result, whereas RBW (< 1 MHz) is the reduced resolution bandwidth of spectrum analyzer set during measurement.
- e) Care must be taken to ensure that the measurements are performed during a period of continuous transmission or are corrected upward for duty cycle.

Note: As a practical matter, it is recommended to use reduced RBW of 100 KHz for the sections 5.c) and 5.d) above, since RBW=100 KHZ is available on nearly all spectrum analyzers.

5.3 DEVIATION FROM STANDARD

No deviation.

5.4 TEST METHOD

KDB662911 D01 MULTIPLE TRANSMITTER OUTPUT V02R01

KDB789033 D02 GENERAL U-NII TEST PROCEDURES NEW RULES V02R01, SECTION F

5.5 TEST SETUP



5.6 EUT OPERATION CONDITIONS

The EUT tested system was configured as the statements of 2.1 Unless otherwise a special operating condition is specified in the follows during the testing.

5.7 TEST RESULTS

Mode	Frequency (MHz)	Conducted PSD (dBm/MHz)	Limit (dBm/MHz)	Verdict
a	5180	-12.86	11	Pass
a	5200	-13.01	11	Pass
a	5240	-12.74	11	Pass
n20	5180	-13.40	11	Pass
n20	5200	-13.81	11	Pass
n20	5240	-13.17	11	Pass
n40	5190	-15.22	11	Pass
n40	5230	-14.57	11	Pass

Note: Duty cycle Correction Factor = 0 dB.

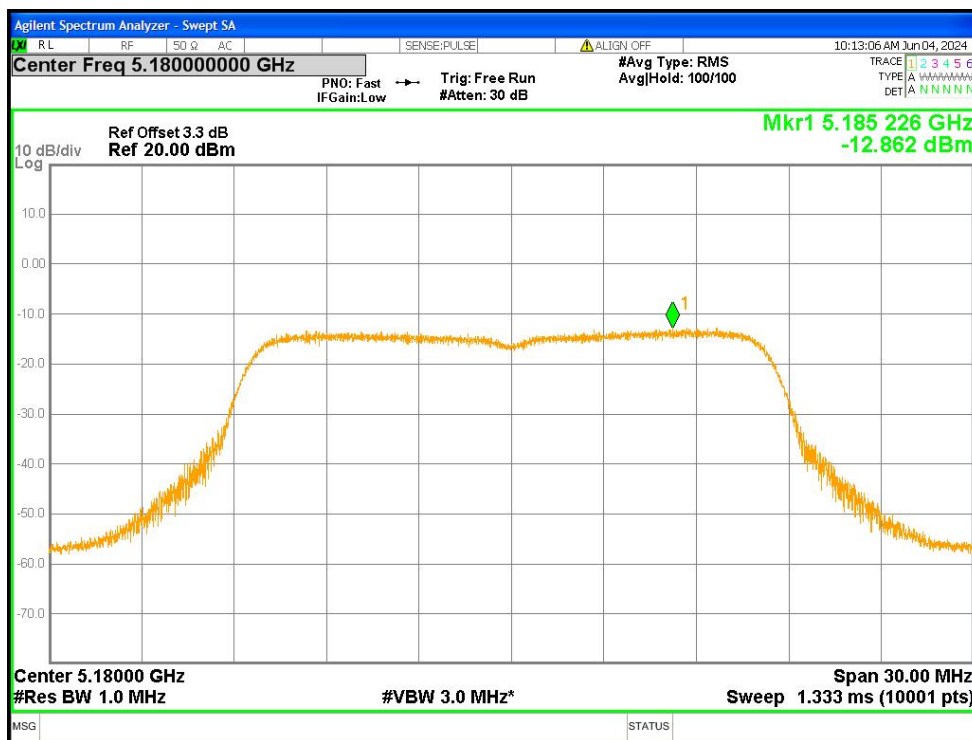

PSD NVNT a 5180MHz Ant1

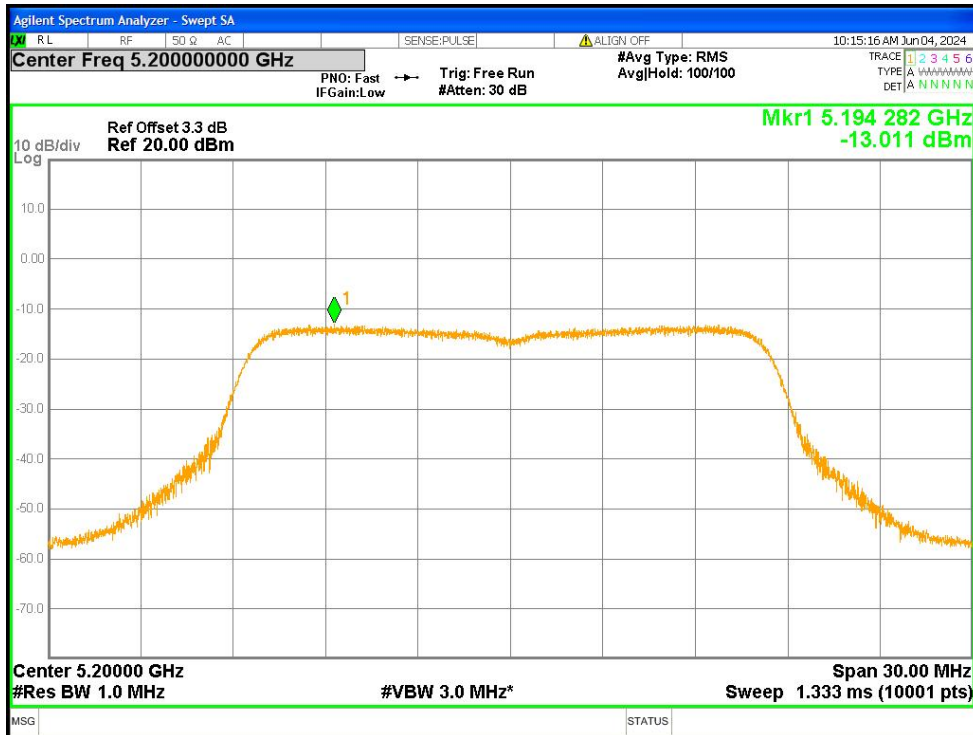

PSD NVNT a 5200MHz Ant1

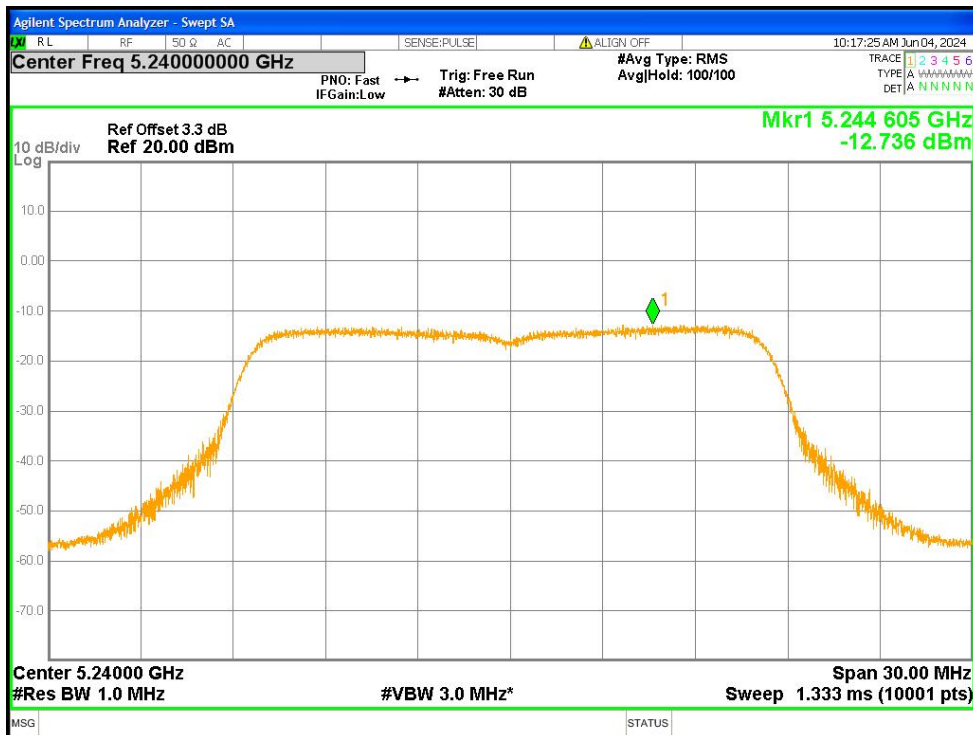

PSD NVNT a 5240MHz Ant1

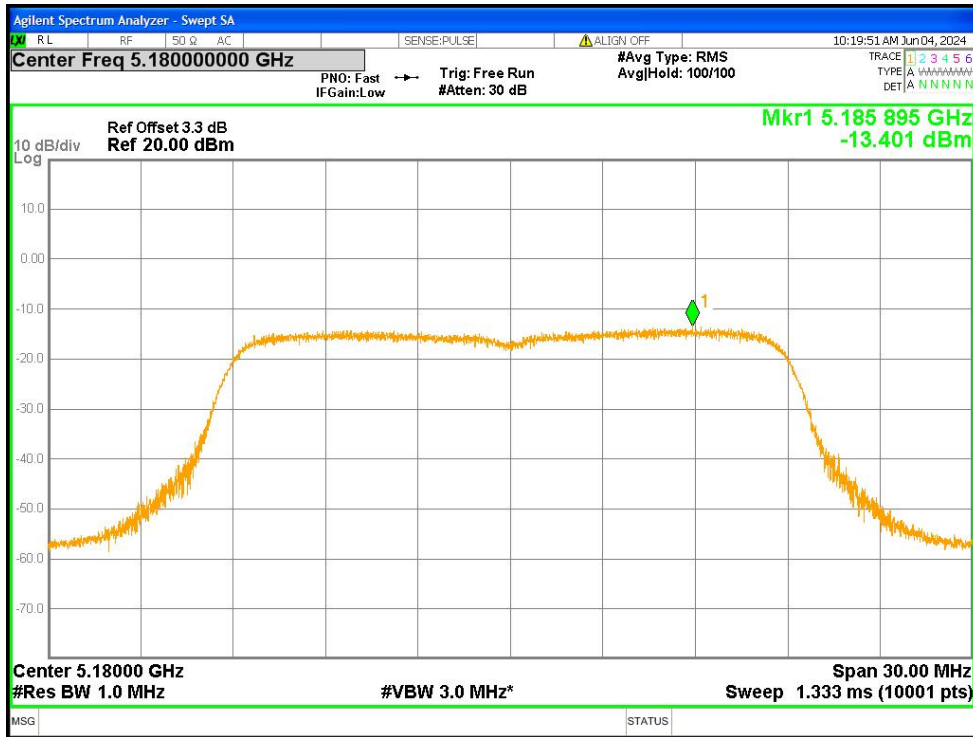

PSD NVNT n20 5180MHz Ant1

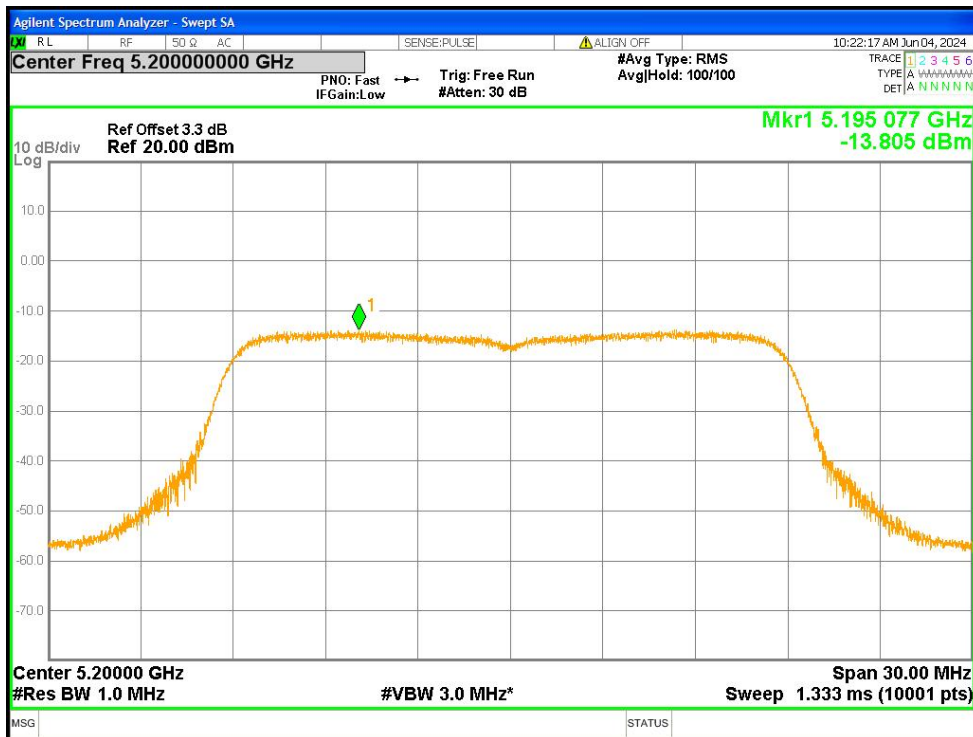

PSD NVNT n20 5200MHz Ant1

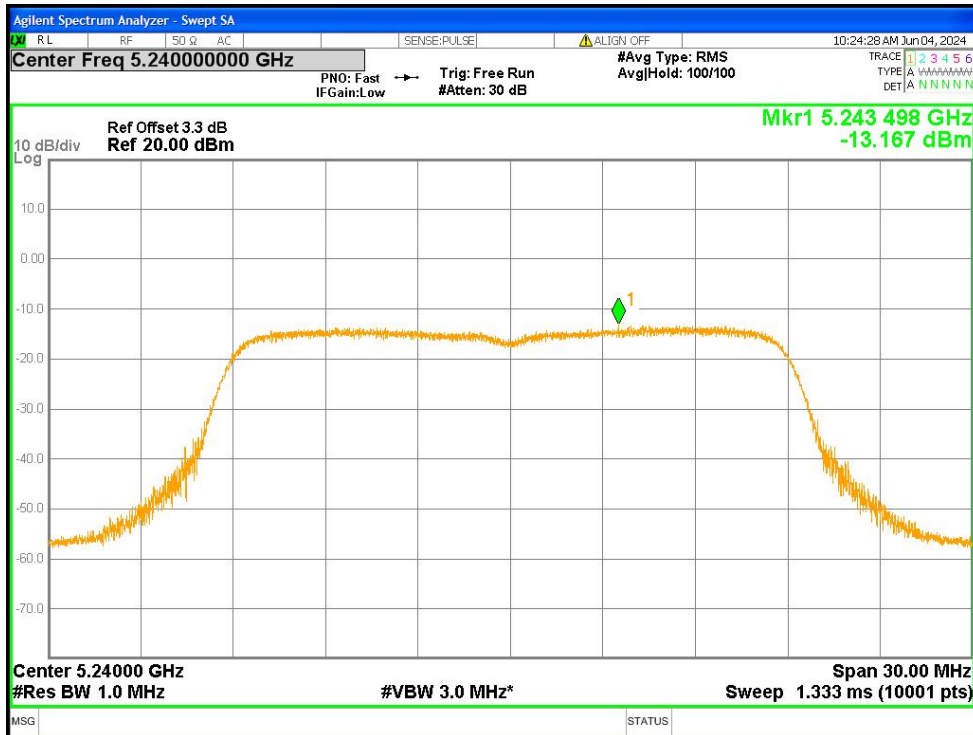

PSD NVNT n20 5240MHz Ant1

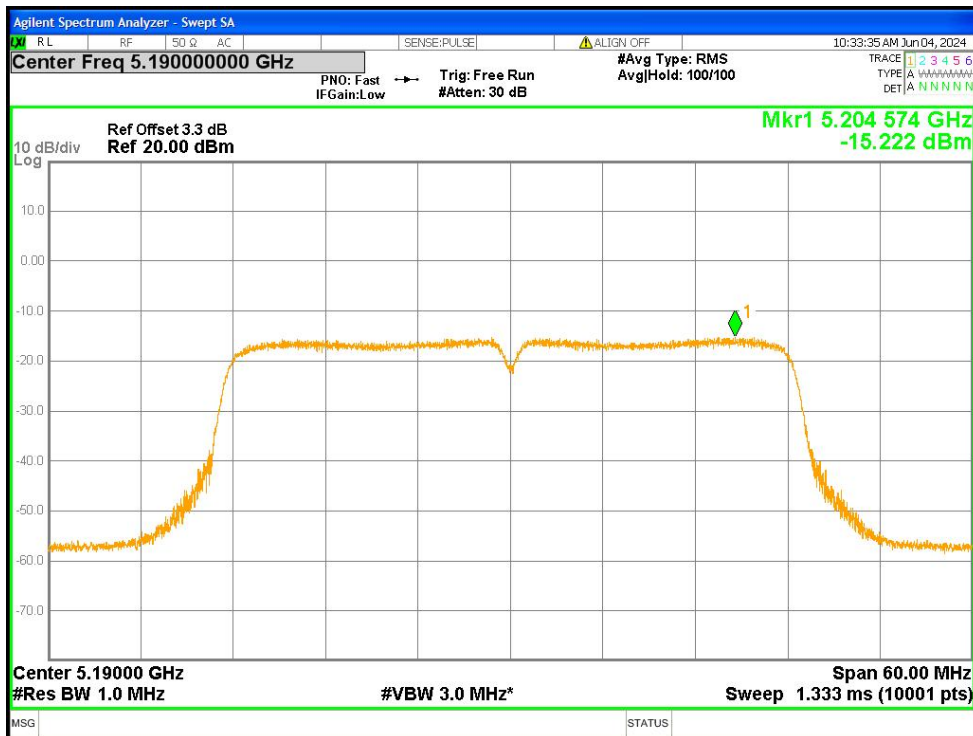

PSD NVNT n40 5190MHz Ant1

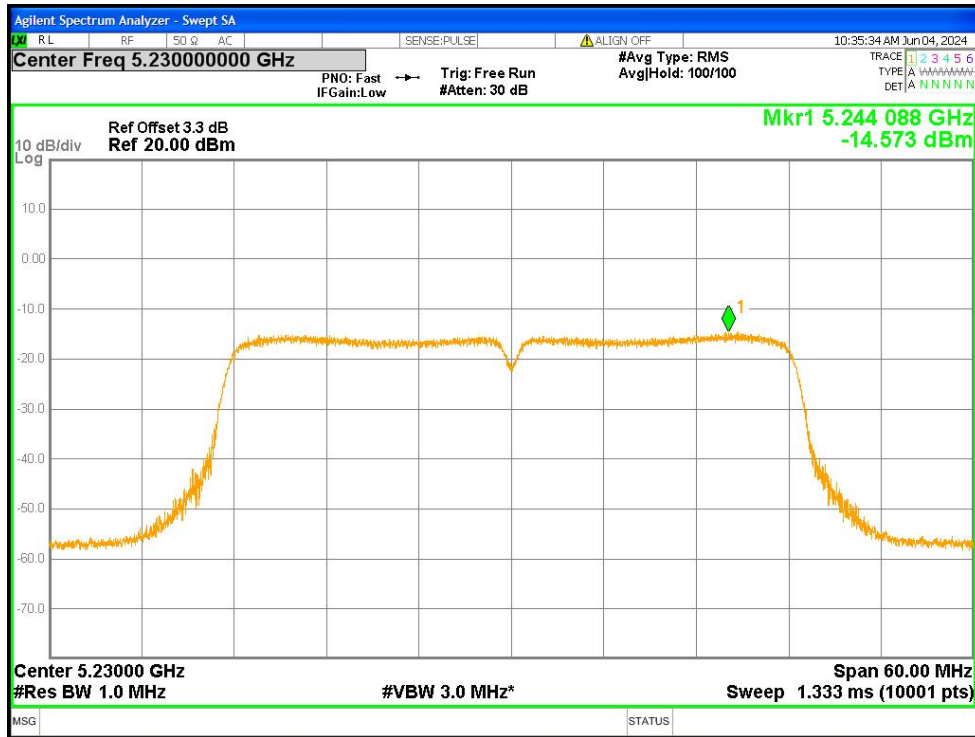

PSD NVNT n40 5230MHz Ant1

6.26DB & 6DB & 99% EMISSION BANDWIDTH

6.1 APPLIED PROCEDURES / LIMIT

The maximum power spectral density is measured as a conducted emission by direct connection of a calibrated test instrument to the equipment under test. If the device cannot be connected directly, alternative techniques acceptable to the Commission may be used. Measurements in the 5.725-5.85 GHz band, the minimum bandwidth 6 dB bandwidth of U-NII devices shall be at least 500KHz. Measurements in the 5.15-5.25 GHz, 5.25-5.35 GHz, and the 5.47-5.725 GHz bands are made over a bandwidth of 1 MHz or the 26 dB emission bandwidth of the device, whichever is less. A narrower resolution bandwidth can be used, provided that the measured power is integrated over the full reference bandwidth.

6.2 TEST PROCEDURE

- a) Set RBW = 100KHz.
- b) Set the VBW > RBW.
- c) Detector = Peak.
- d) Trace mode = max hold.
- e) Measure the maximum width of the emission that is constrained by the frequencies associated with the two outermost amplitude points (upper and lower frequencies) that are attenuated by 6 dB relative to the maximum level measured in the fundamental emission.

The following procedure shall be used for measuring (99 %) power bandwidth:

- 1. Set center frequency to the nominal EUT channel center frequency.
- 2. Set span = 1.5 times to 5.0 times the OBW.
- 3. Set RBW = 1 % to 5 % of the OBW
- 4. Set VBW $\geq 3 \cdot$ RBW
- 5. Video averaging is not permitted. Where practical, a sample detection and single sweep mode shall be used. Otherwise, peak detection and max hold mode (until the trace stabilizes) shall be used.
- 6. Use the 99 % power bandwidth function of the instrument (if available).
- 7. If the instrument does not have a 99 % power bandwidth function, the trace data points are recovered and directly summed in power units. The recovered amplitude data points, beginning at the lowest frequency, are placed in a running sum until 0.5 % of the total is reached; that frequency is recorded as the lower frequency. The process is repeated until 99.5 % of the total is reached; that frequency is recorded as the upper frequency. The 99% occupied bandwidth is the difference between these two frequencies.



6.3 EUT OPERATION CONDITIONS

The EUT tested system was configured as the statements of 2.4 Unless otherwise a special operating condition is specified in the follows during the testing.

6.4 TEST RESULTS

Mode	Frequency (MHz)	99% OBW (MHz)	-26dB OBW
a	5180	16.53	20.05
a	5200	16.548	20.37
a	5240	16.513	20.11
n20	5180	17.645	21.02
n20	5200	17.668	21.08
n20	5240	17.648	20.95
n40	5190	36.114	41.44
n40	5230	36.2	41.87

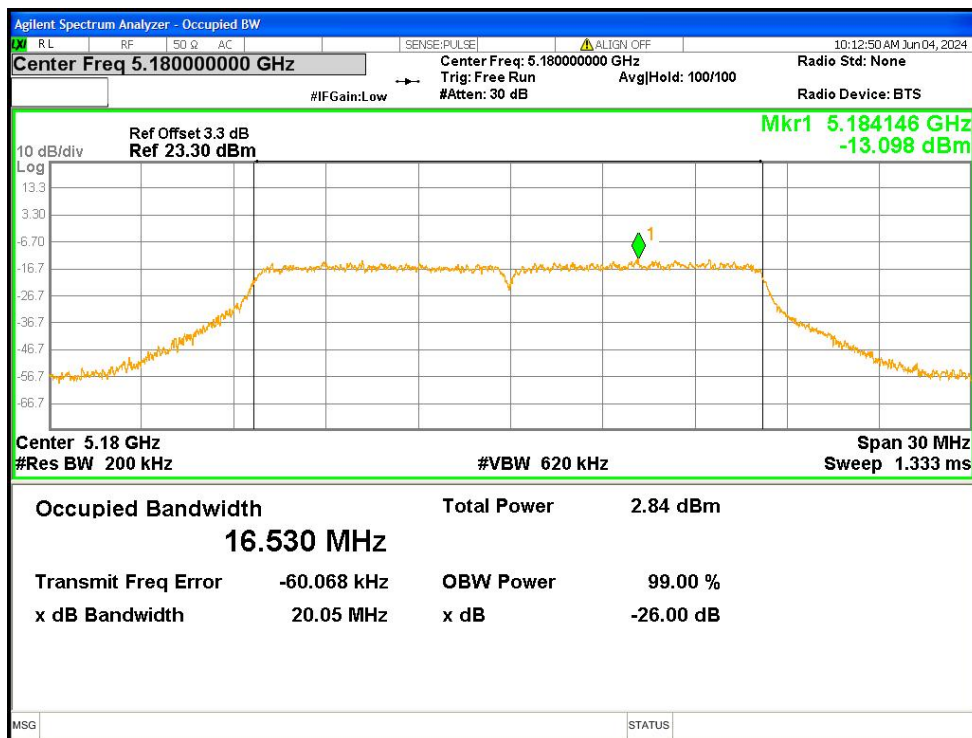

OBW NVNT a 5180MHz Ant1

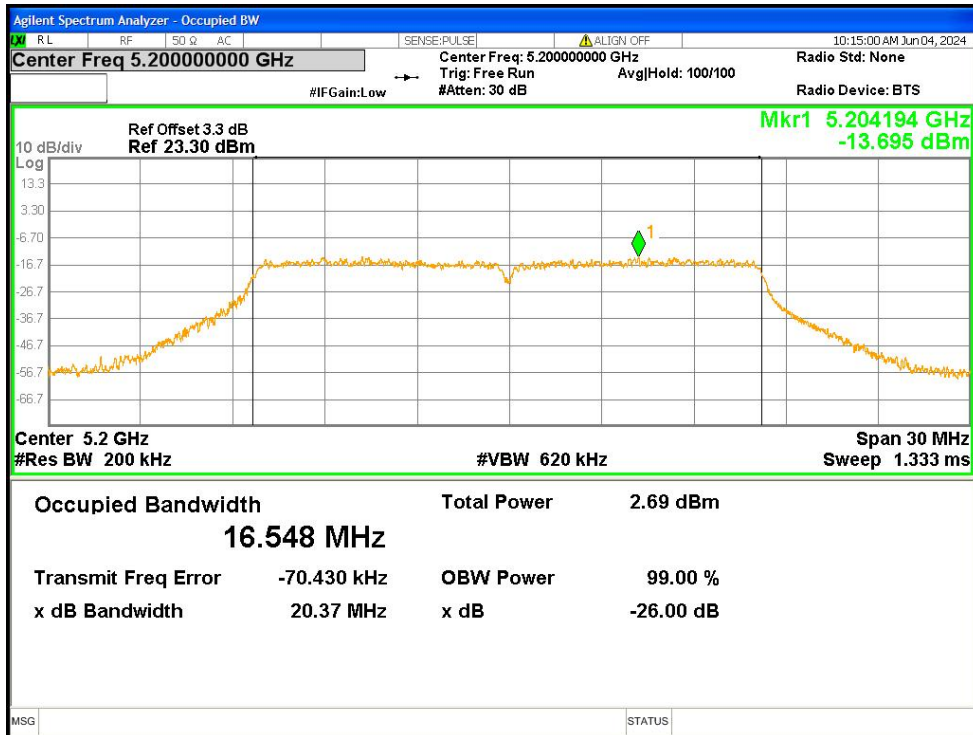

OBW NVNT a 5200MHz Ant1

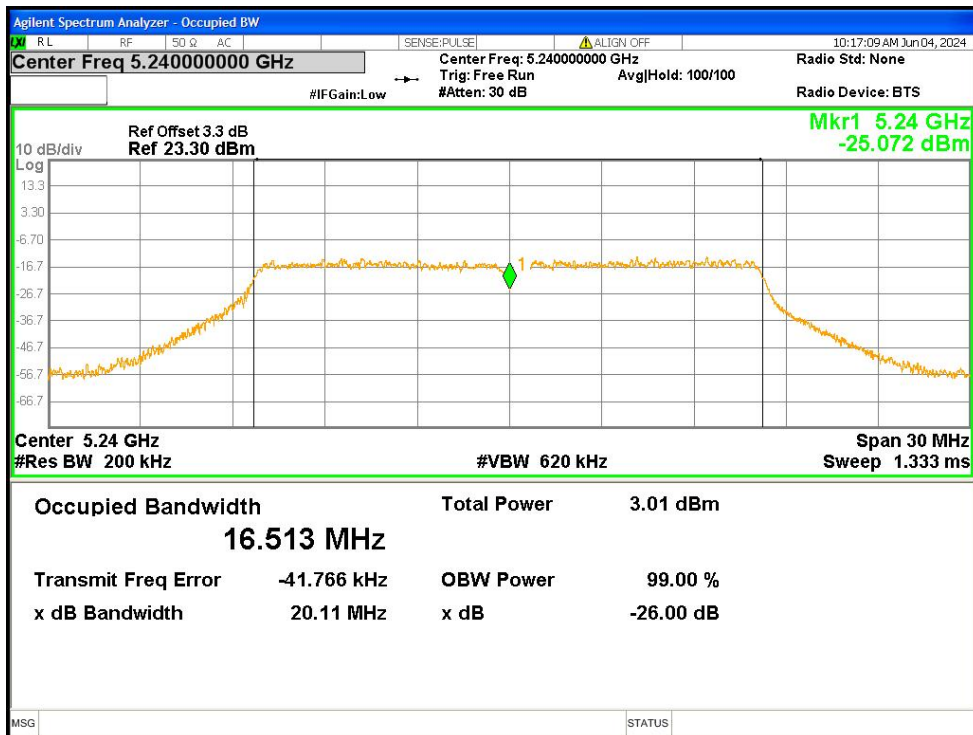

OBW NVNT a 5240MHz Ant1

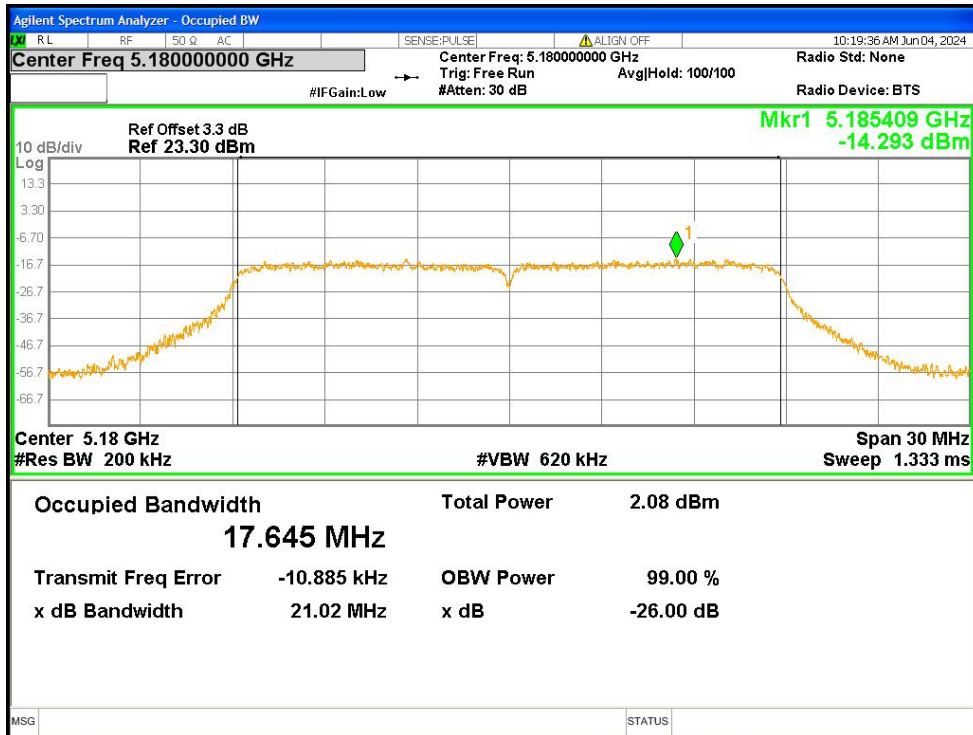

OBW NVNT n20 5180MHz Ant1

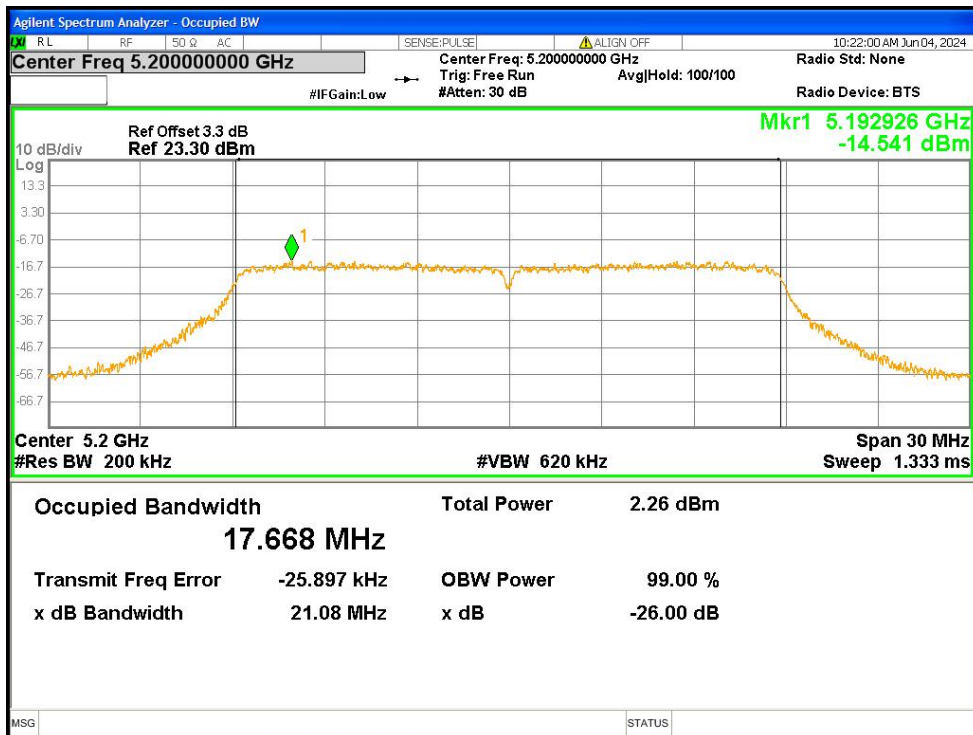

OBW NVNT n20 5200MHz Ant1

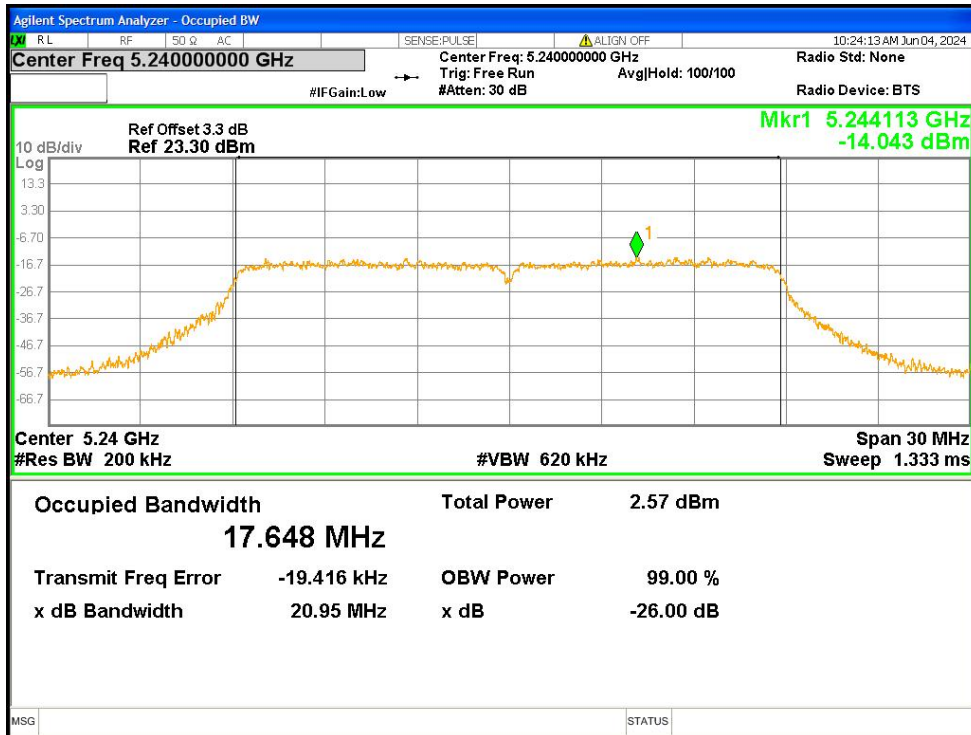

OBW NVNT n20 5240MHz Ant1

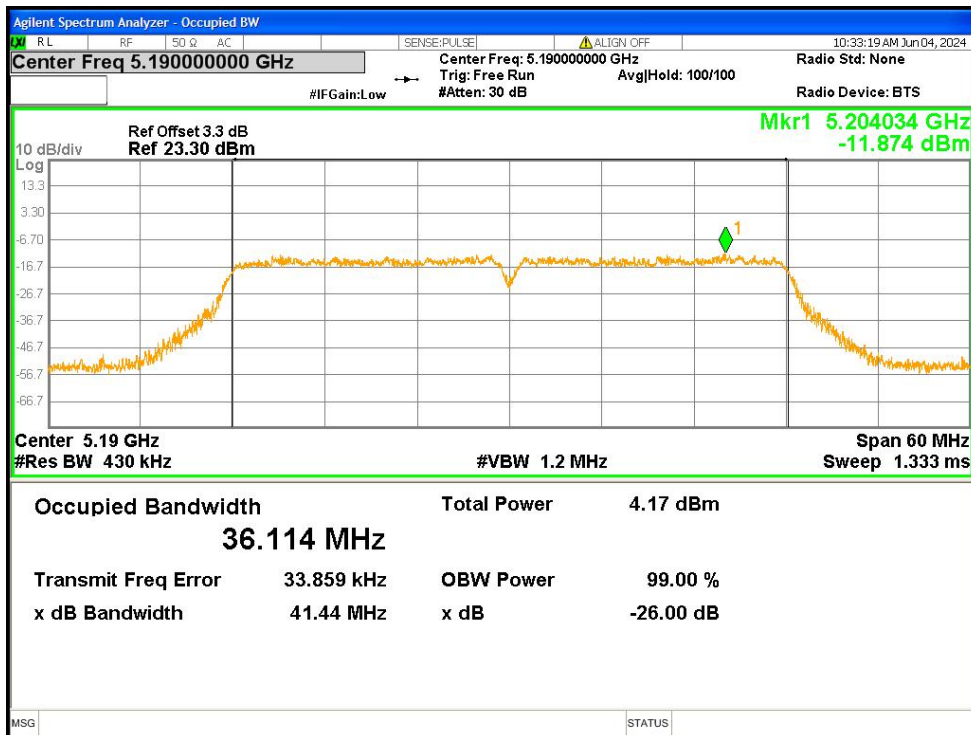

OBW NVNT n40 5190MHz Ant1

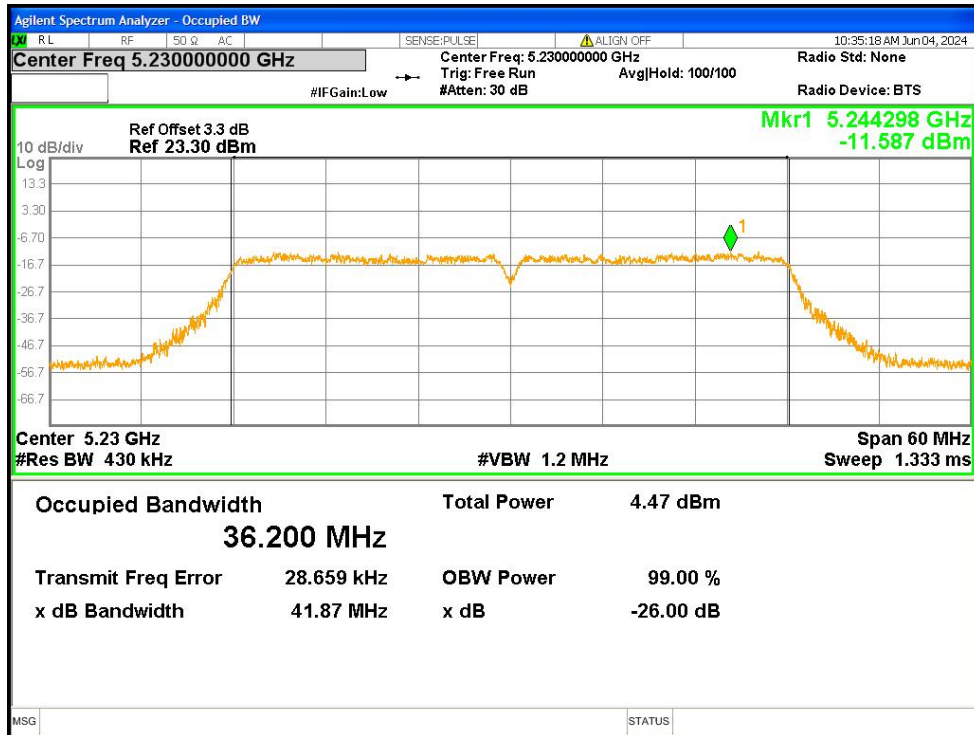

OBW NVNT n40 5230MHz Ant1

7. MAXIMUM CONDUCTED OUTPUT POWER

7.1 PPLIED PROCEDURES / LIMIT

According to FCC §15.407

The maximum conducted output power should not exceed:

Frequency Band(MHz)	Limit
5150~5250	250mW
5725-5850	1W

7.2 TEST PROCEDURE

The EUT was directly connected to the Power meter

1. Device Configuration

If possible, configure or modify the operation of the EUT so that it transmits continuously at its maximum power control level (see section II.B.).

a) The intent is to test at 100 percent duty cycle; however a small reduction in duty cycle (to no lower than 98 percent) is permitted if required by the EUT for amplitude control purposes. Manufacturers are expected to provide software to the test lab to permit such continuous operation.

b) If continuous transmission (or at least 98 percent duty cycle) cannot be achieved due to hardware limitations (e.g., overheating), the EUT shall be operated at its maximum power control level with the transmit duration as long as possible and the duty cycle as high as possible.

2. Measurement using a Spectrum Analyzer or EMI Receiver (SA)

Measurement of maximum conducted output power using a spectrum analyzer requires integrating the spectrum across a frequency span that encompasses, at a minimum, either the EBW or the 99-percent occupied bandwidth of the signal. However, the EBW must be used to determine bandwidth dependent limits on maximum conducted output power in accordance with § 15.407(a).

a) The test method shall be selected as follows: (i) Method SA-1 or SA-1 Alternative (averaging with the EUT transmitting at full power throughout each sweep) shall be applied if either of the following conditions can be satisfied:

- The EUT transmits continuously (or with a duty cycle ≥ 98 percent).
- Sweep triggering or gating can be implemented in a way that the device transmits at the maximum power control level throughout the duration of each of the instrument sweeps to be averaged. This condition can generally be achieved by triggering the instrument's sweep if the duration of the sweep (with the analyzer configured as in Method SA-1, below) is equal to or shorter than the duration T of each transmission from the EUT and if those transmissions exhibit full power throughout their durations.

(ii) Method SA-2 or SA-2 Alternative (averaging across on and off times of the EUT transmissions, followed by duty cycle correction) shall be applied if the conditions of (i) cannot be achieved and the transmissions exhibit a constant duty cycle during the measurement duration. Duty cycle will be considered to be constant if variations are less than ± 2 percent.

(iii) Method SA-3 (RMS detection with max hold) or SA-3 Alternative (reduced VBW with max hold) shall be applied if the conditions of (i) and (ii) cannot be achieved.

b) Method SA-1 (trace averaging with the EUT transmitting at full power throughout each sweep): (i) Set span to encompass the entire emission bandwidth (EBW) (or, alternatively, the entire 99% occupied bandwidth) of the signal.

(ii) Set RBW = 1 MHz.

(iii) Set VBW ≥ 3 MHz.

(iv) Number of points in sweep ≥ 2 Span / RBW. (This ensures that bin-to-bin spacing is \leq RBW/2, so that narrowband signals are not lost between frequency bins.)

(v) Sweep time = auto.

(vi) Detector = RMS (i.e., power averaging), if available. Otherwise, use sample detector mode.

(vii) If transmit duty cycle < 98 percent, use a video trigger with the trigger level set to enable triggering only on full power pulses. Transmitter must operate at maximum power control level for the entire duration of every sweep. If the EUT transmits continuously (i.e., with no off intervals) or at duty cycle ≥ 98 percent, and if each transmission is entirely at the maximum power control level, then the trigger shall be set to "free run".

(viii) Trace average at least 100 traces in power averaging (i.e., RMS) mode.

(ix) Compute power by integrating the spectrum across the EBW (or, alternatively, the entire 99% occupied bandwidth) of the signal using the instrument's band power measurement function with band limits set equal to the EBW (or occupied bandwidth) band edges. If the instrument does not have a band power function, sum the spectrum

7.3 DEVIATION FROM STANDARD

No deviation.

7.4 TEST SETUP



7.5 EUT OPERATION CONDITIONS

The EUT tested system was configured as the statements of 2.4 Unless otherwise a special operating condition is specified in the follows during the testing.

7.6 TEST RESULTS

Mode	Frequency (MHz)	Conducted Power (dBm)	Limit (dBm)	Verdict
a	5180	-2.39	24	Pass
a	5200	-2.52	24	Pass
a	5240	-2.24	24	Pass
n20	5180	-3.1	24	Pass
n20	5200	-2.99	24	Pass
n20	5240	-2.57	24	Pass
n40	5190	-1.23	24	Pass
n40	5230	-0.91	24	Pass

Note: Duty cycle Correction Factor = 0 dB.

8.OUT OF BAND EMISSIONS

8.1 APPLICABLE STANDARD

According to FCC §15.407(b) FCC §15.407

For FCC Limit

Undesirable emission limits. Except as shown in paragraph (b)(7) of this section, the maximum emissions outside of the frequency bands of operation shall be attenuated in accordance with the following limits:

(1) For transmitters operating in the 5.15-5.25 GHz band: All emissions outside of the 5.15-5.35 GHz band shall not exceed an e.i.r.p. of -27 dBm/MHz.

(2) For transmitters operating in the 5.25-5.35 GHz band: All emissions outside of the 5.15-5.35 GHz band shall not exceed an e.i.r.p. of -27 dBm/MHz.

(3) For transmitters operating in the 5.47-5.725 GHz band: All emissions outside of the 5.47-5.725 GHz band shall not exceed an e.i.r.p. of -27 dBm/MHz.

(4) For transmitters operating in the 5.725-5.85 GHz band:

(i) All emissions shall be limited to a level of -27 dBm/MHz at 75 MHz or more above or below the band edge increasing linearly to 10 dBm/MHz at 25 MHz above or below the band edge, and from 25 MHz above or below the band edge increasing linearly to a level of 15.6 dBm/MHz at 5 MHz above or below the band edge, and from 5 MHz above or below the band edge increasing linearly to a level of 27 dBm/MHz at the band edge.

(ii) Devices certified before March 2, 2017 with antenna gain greater than 10 dBi may demonstrate compliance with the emission limits in §15.247(d), but manufacturing, marketing and importing of devices certified under this alternative must cease by March 2, 2018. Devices certified before March 2, 2018 with antenna gain of 10 dBi or less may demonstrate compliance with the emission limits in §15.247(d), but manufacturing, marketing and importing of devices certified under this alternative must cease before March 2, 2020.

Frequency Band (MHz)	Function	Resolution bandwidth	Video Bandwidth
30 to 1000	QP	120 kHz	300 kHz
Above 1000	Peak	1 MHz	1 MHz
	Average	1 MHz	10 Hz

8.2 TEST PROCEDURE

Refer to section 4.2.5

8.3 DEVIATION FROM STANDARD

No deviation.

8.4 TEST SETUP

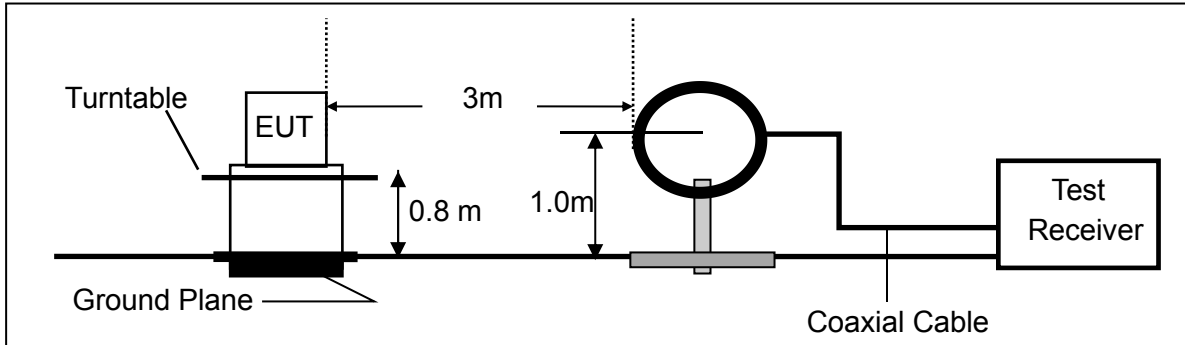

2. For radiated emissions from 30MHz to 1000MHz

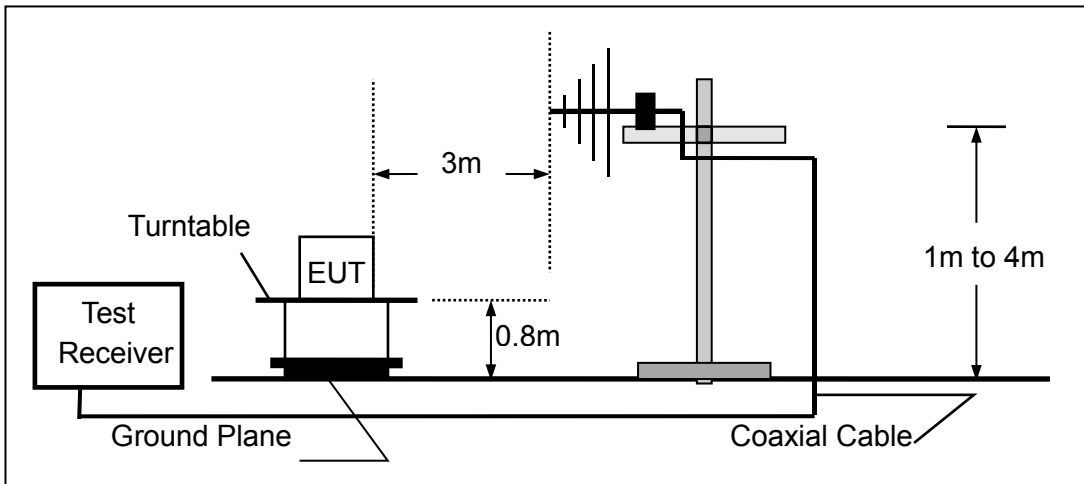

3. Radiated Emission Test-Up Frequency Above 1GHz

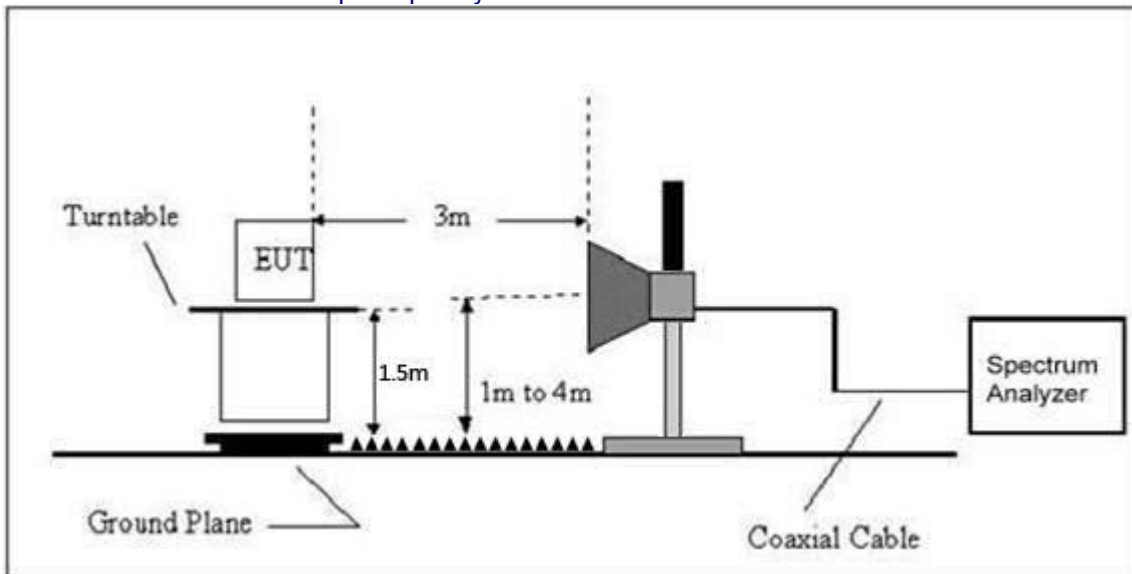

8.5 EUT OPERATION CONDITIONS

The EUT tested system was configured as the statements of 2.4 Unless otherwise a special operating condition is specified in the follows during the testing.

8.6 TEST RESULTS

Temperature:	26°C	Relative Humidity:	54%
Pressure:	101kPa	Polarization:	Horizontal
Test Voltage:	DC 3.8V	Test channel	5180MHz(802.11a Worst case)

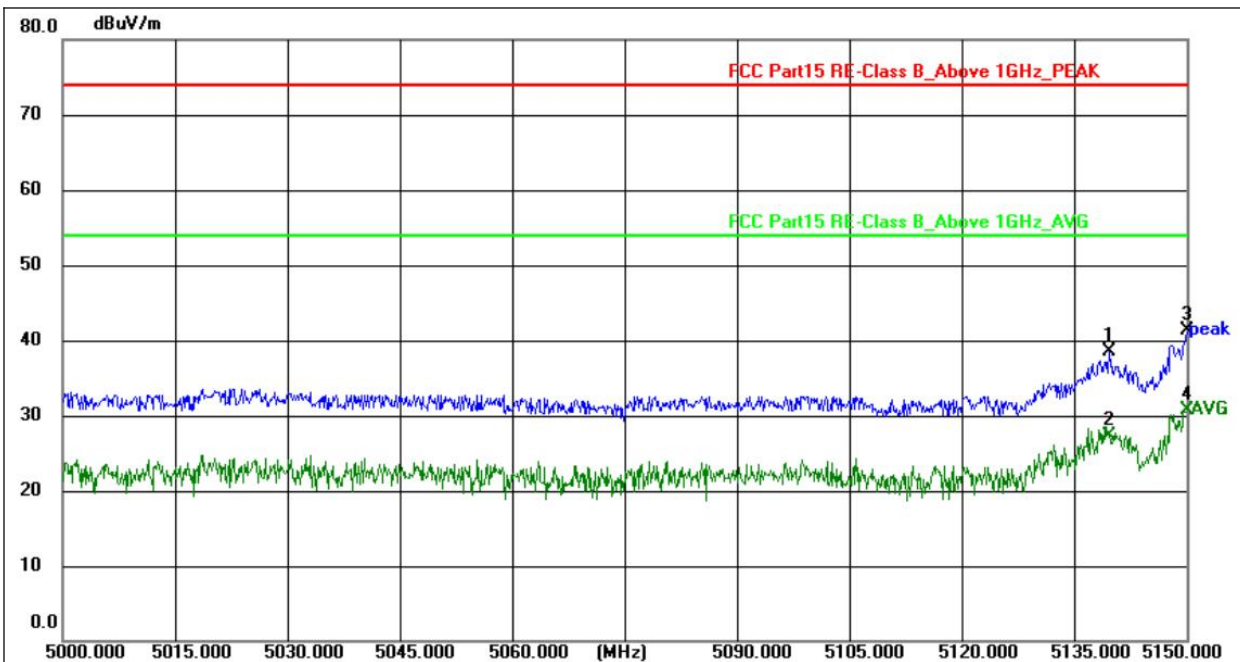

No.	Frequency (MHz)	Reading (dBuV)	Factor (dB/m)	Level (dBuV/m)	Limit (dBuV/m)	Margin (dB)	Detector
1	5139.650	35.91	2.65	38.56	74.00	-35.44	peak
2	5139.650	24.68	2.65	27.33	54.00	-26.67	AVG
3	5150.000	38.56	2.67	41.23	74.00	-32.77	peak
4 *	5150.000	27.99	2.67	30.66	54.00	-23.34	AVG

Temperature:	26°C	Relative Humidity:	54%
Pressure:	101kPa	Polarization:	Vertical
Test Voltage:	DC 3.8V	Test channel	5180MHz(802.11a Worst case)

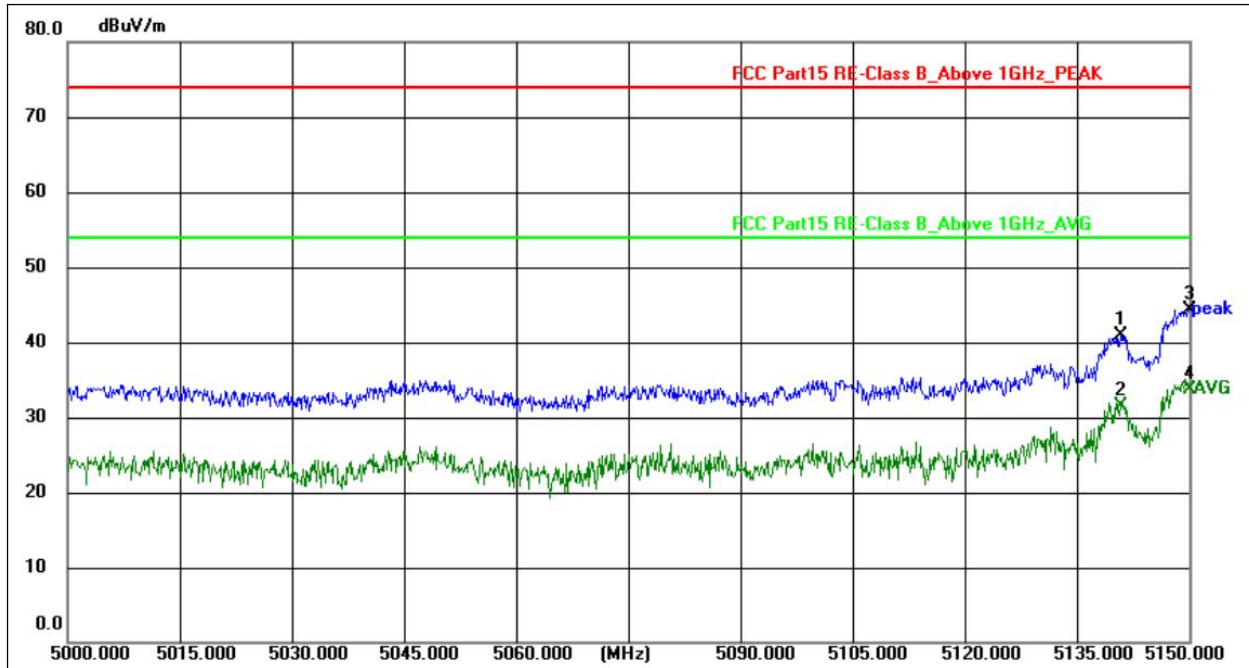

No.	Frequency (MHz)	Reading (dBuV)	Factor (dB/m)	Level (dBuV/m)	Limit (dBuV/m)	Margin (dB)	Detector
1	5140.850	38.28	2.65	40.93	74.00	-33.07	peak
2	5140.850	28.77	2.65	31.42	54.00	-22.58	AVG
3	5150.000	41.56	2.67	44.23	74.00	-29.77	peak
4 *	5150.000	30.99	2.67	33.66	54.00	-20.34	AVG

Temperature:	26°C	Relative Humidity:	54%
Pressure:	101kPa	Polarization:	Horizontal
Test Voltage:	DC 3.8V	Test channel	5240MHz(802.11a Worst case)

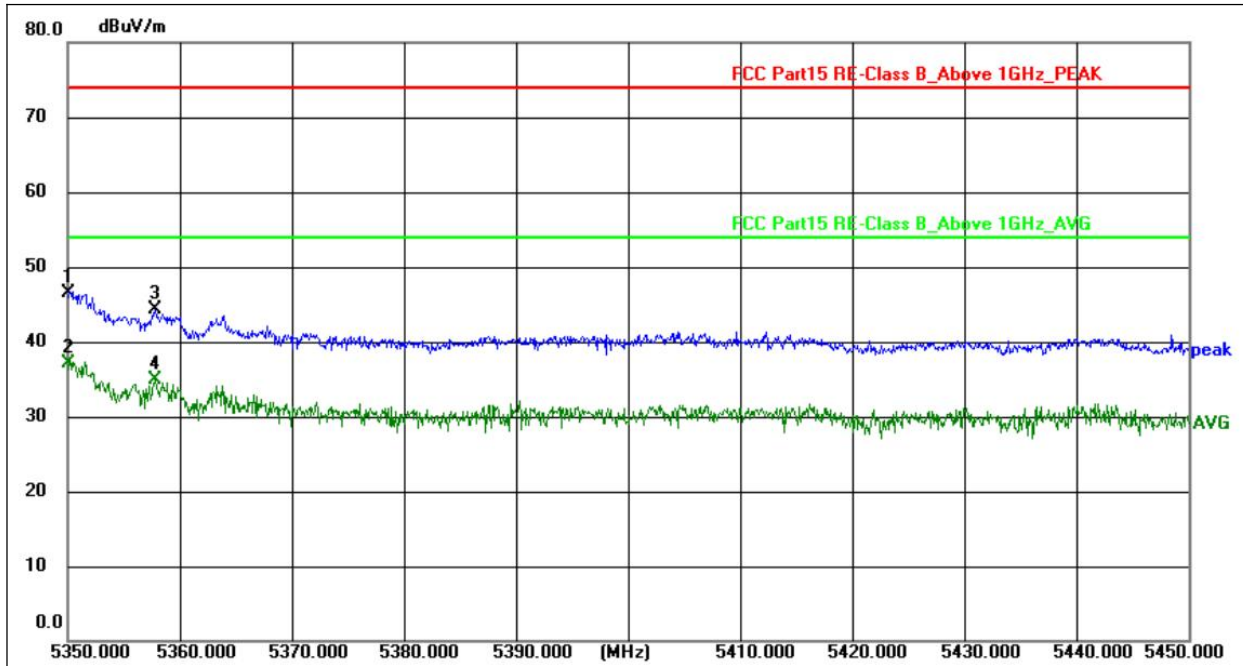

No.	Frequency (MHz)	Reading (dBuV)	Factor (dB/m)	Level (dBuV/m)	Limit (dBuV/m)	Margin (dB)	Detector
1	5350.000	42.79	3.72	46.51	74.00	-27.49	peak
2 *	5350.000	33.45	3.72	37.17	54.00	-16.83	AVG
3	5357.800	40.49	3.74	44.23	74.00	-29.77	peak
4	5357.800	31.13	3.74	34.87	54.00	-19.13	AVG

Temperature:	26°C	Relative Humidity:	54%
Pressure:	101kPa	Polarization:	Vertical
Test Voltage:	DC 3.8V	Test channel	5240MHz(802.11a Worst case)

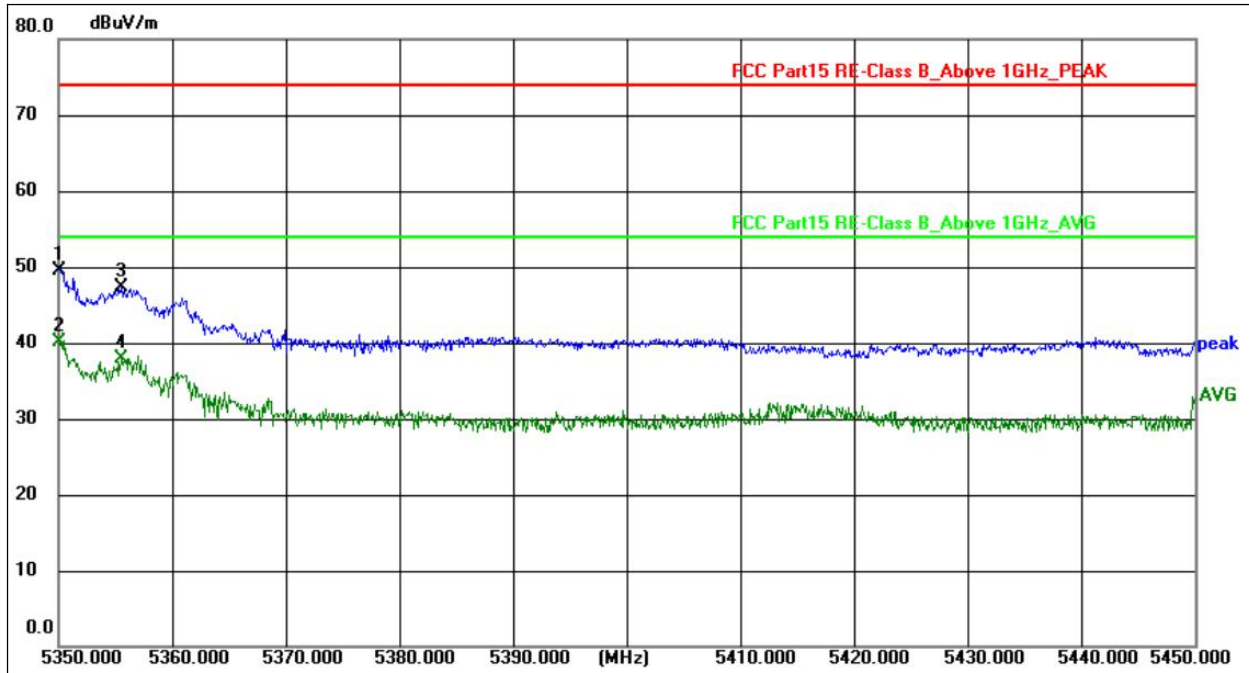

No.	Frequency (MHz)	Reading (dBuV)	Factor (dB/m)	Level (dBuV/m)	Limit (dBuV/m)	Margin (dB)	Detector
1	5350.000	45.79	3.72	49.51	74.00	-24.49	peak
2 *	5350.000	36.45	3.72	40.17	54.00	-13.83	AVG
3	5355.500	43.49	3.72	47.21	74.00	-26.79	peak
4	5355.500	34.14	3.72	37.86	54.00	-16.14	AVG

Temperature:	26°C	Relative Humidity:	54%
Pressure:	101kPa	Polarization:	Horizontal
Test Voltage:	DC 3.8V	Test channel	5190MHz(802.11 n40)

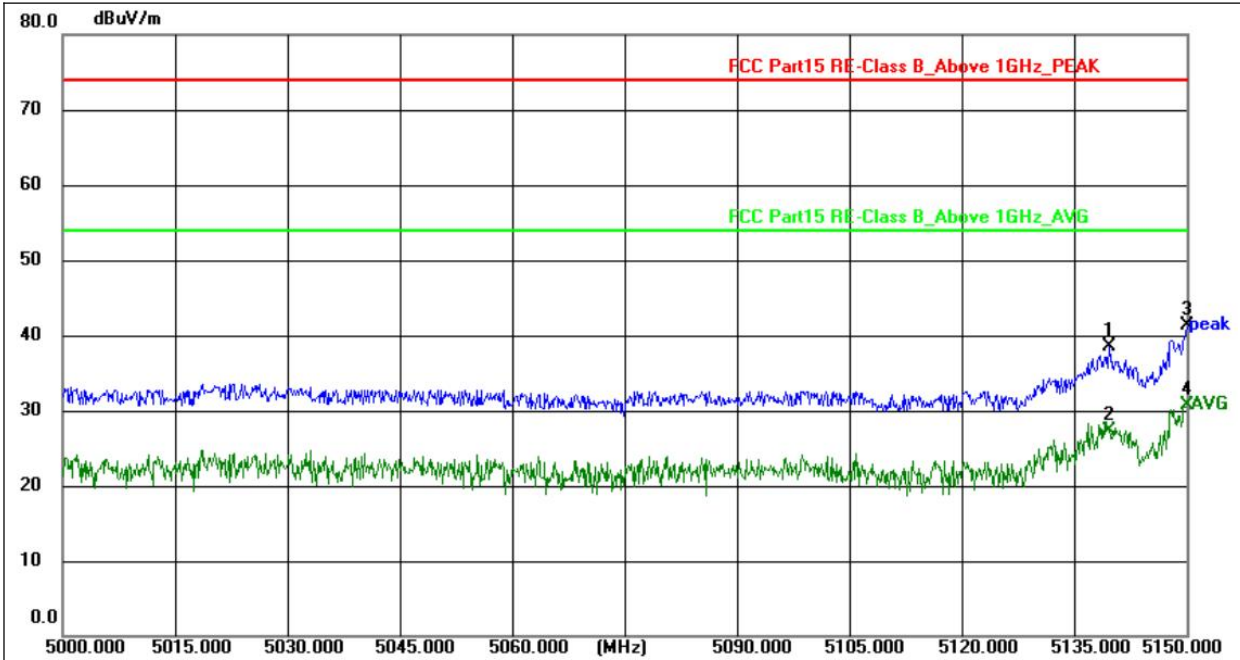

No.	Frequency (MHz)	Reading (dBuV)	Factor (dB/m)	Level (dBuV/m)	Limit (dBuV/m)	Margin (dB)	Detector
1	5139.650	35.91	2.65	38.56	74.00	-35.44	peak
2	5139.650	24.68	2.65	27.33	54.00	-26.67	AVG
3	5150.000	38.56	2.67	41.23	74.00	-32.77	peak
4 *	5150.000	27.99	2.67	30.66	54.00	-23.34	AVG

Temperature:	26°C	Relative Humidity:	54%
Pressure:	101kPa	Polarization:	Vertical
Test Voltage:	DC 3.8V	Test channel	5190MHz(802.11 n40)

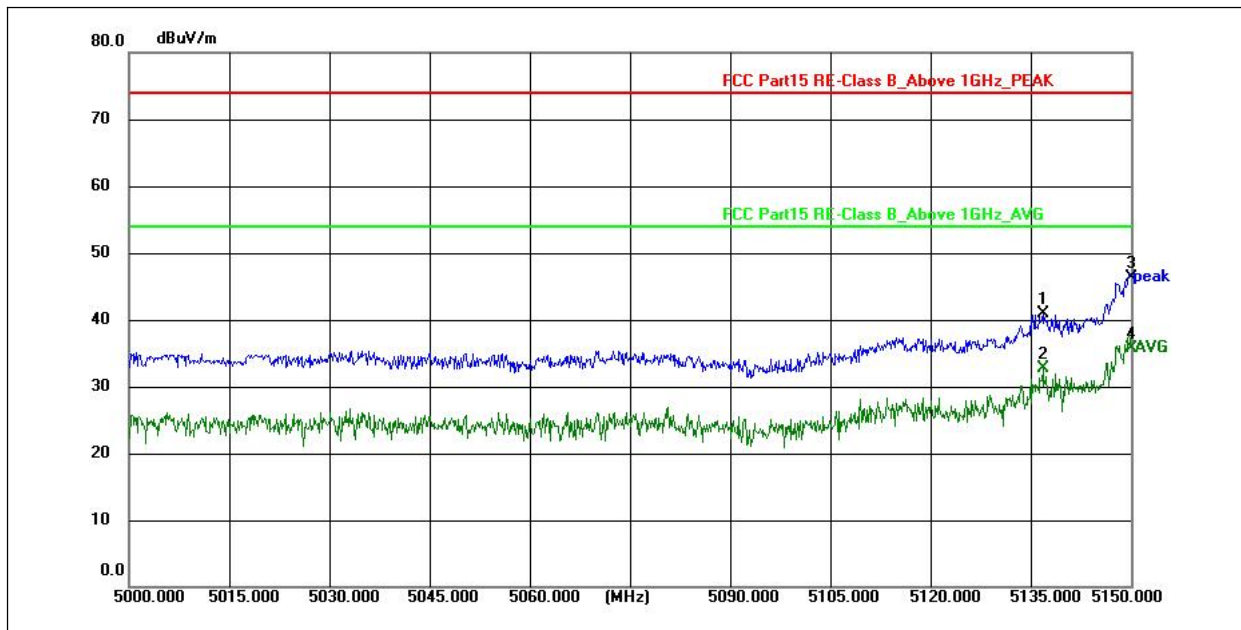

No.	Frequency (MHz)	Reading (dBuV)	Factor (dB/m)	Level (dBuV/m)	Limit (dBuV/m)	Margin (dB)	Detector
1	5136.800	38.25	2.65	40.90	74.00	-33.10	peak
2	5136.800	30.10	2.65	32.75	54.00	-21.25	AVG
3	5150.000	43.56	2.67	46.23	74.00	-27.77	peak
4 *	5150.000	32.99	2.67	35.66	54.00	-18.34	AVG

Temperature:	26°C	Relative Humidity:	54%
Pressure:	101kPa	Polarization:	Horizontal
Test Voltage:	DC 3.8V	Test channel	5230MHz(802.11 n40)

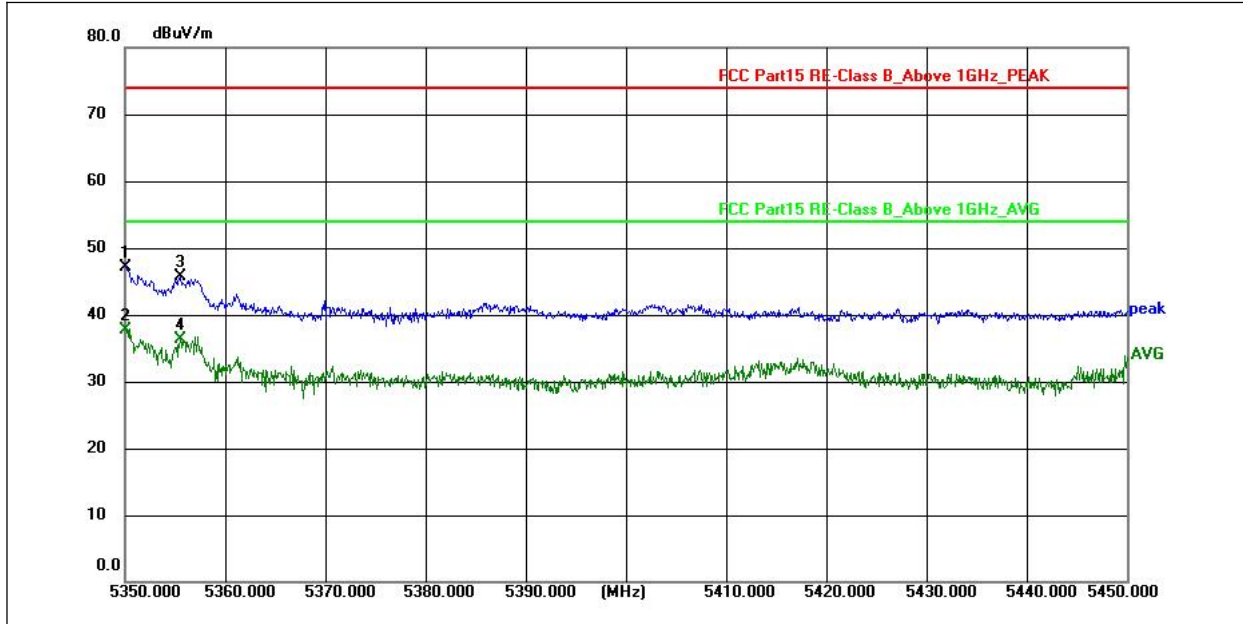

No.	Frequency (MHz)	Reading (dBuV)	Factor (dB/m)	Level (dBuV/m)	Limit (dBuV/m)	Margin (dB)	Detector
1	5350.000	43.29	3.72	47.01	74.00	-26.99	peak
2 *	5350.000	33.95	3.72	37.67	54.00	-16.33	AVG
3	5355.500	41.99	3.72	45.71	74.00	-28.29	peak
4	5355.500	32.64	3.72	36.36	54.00	-17.64	AVG

Temperature:	26°C	Relative Humidity:	54%
Pressure:	101kPa	Polarization:	Vertical
Test Voltage:	DC 3.8V	Test channel	5230MHz(802.11 n40)

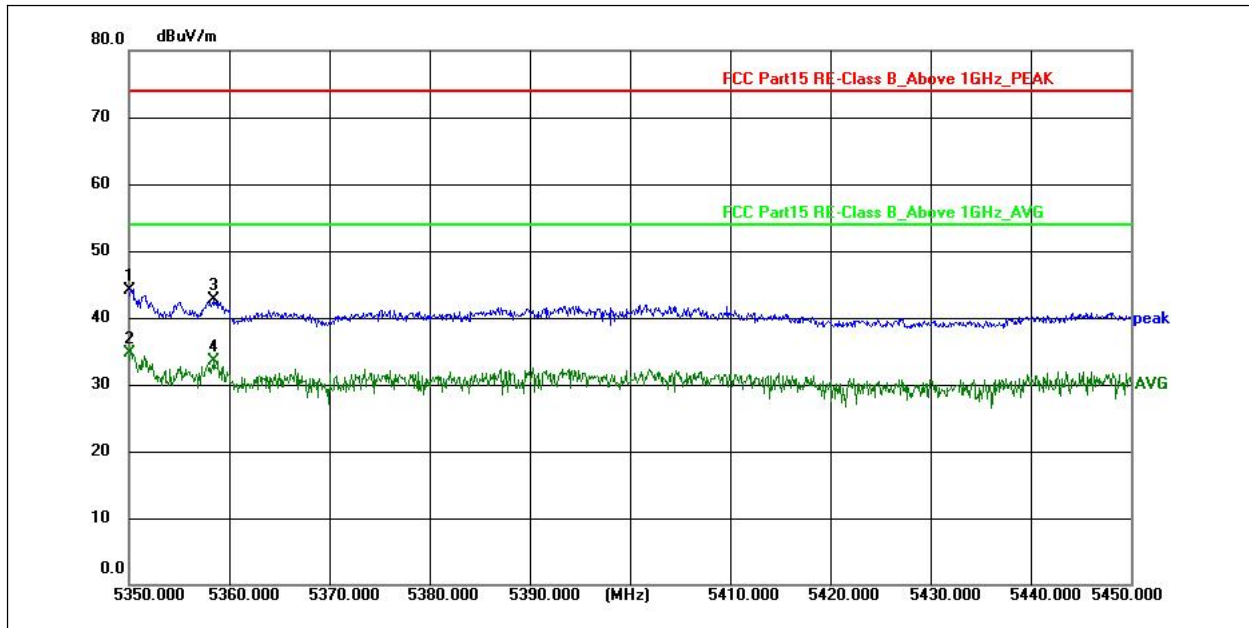

No.	Frequency (MHz)	Reading (dBuV)	Factor (dB/m)	Level (dBuV/m)	Limit (dBuV/m)	Margin (dB)	Detector
1	5350.000	40.29	3.72	44.01	74.00	-29.99	peak
2 *	5350.000	30.95	3.72	34.67	54.00	-19.33	AVG
3	5358.500	38.96	3.74	42.70	74.00	-31.30	peak
4	5358.500	29.69	3.74	33.43	54.00	-20.57	AVG

10.Frequency Stability Measurement

10.1 LIMIT

Manufactures of U-NII devices are responsible for ensuring frequency stability such that an emission is maintained within the band of operation under all conditions of normal operation as specified in the user's manual.

The transmitter center frequency tolerance shall be ± 20 ppm maximum for the 5 GHz band (IEEE 802.11n specification).

10.2 TEST PROCEDURES

1. The transmitter output (antenna port) was connected to the spectrum analyzer.
2. EUT have transmitted absence of modulation signal and fixed channelize.
3. Set the spectrum analyzer span to view the entire absence of modulation emissions bandwidth.
4. Set RBW = 10 kHz, VBW = 10 kHz with peak detector and max hold settings.
5. f_c is declaring of channel frequency. Then the frequency error formula is $(f_c - f)/f_c \times 10^6$ ppm and the limit is less than ± 20 ppm (IEEE 802.11n specification).
6. The test extreme voltage is to change the primary supply voltage from 85 to 115 percent of the nominal value
7. Extreme temperature is $-20^\circ\text{C} \sim 70^\circ\text{C}$.

10.3 TEST SETUP LAYOUT



10.4 EUT OPERATION DURING TEST

The EUT was programmed to be in continuously un-modulation transmitting mode.

10.5 TEST RESULTS

Mode	Frequency (MHz)	Measured Frequency (MHz)	Frequency Error (Hz)	Deviation (ppm)	Limit (ppm)	Verdict
a	5180	5179.96	-40000	-7.72	25	Pass
a	5200	5199.94	-60000	-11.54	25	Pass
a	5240	5239.96	-40000	-7.63	25	Pass
n20	5180	5179.96	-40000	-7.72	25	Pass
n20	5200	5199.94	-60000	-11.54	25	Pass
n20	5240	5239.96	-40000	-7.63	25	Pass
n40	5190	5190	0	0	25	Pass
n40	5230	5230	0	0	25	Pass

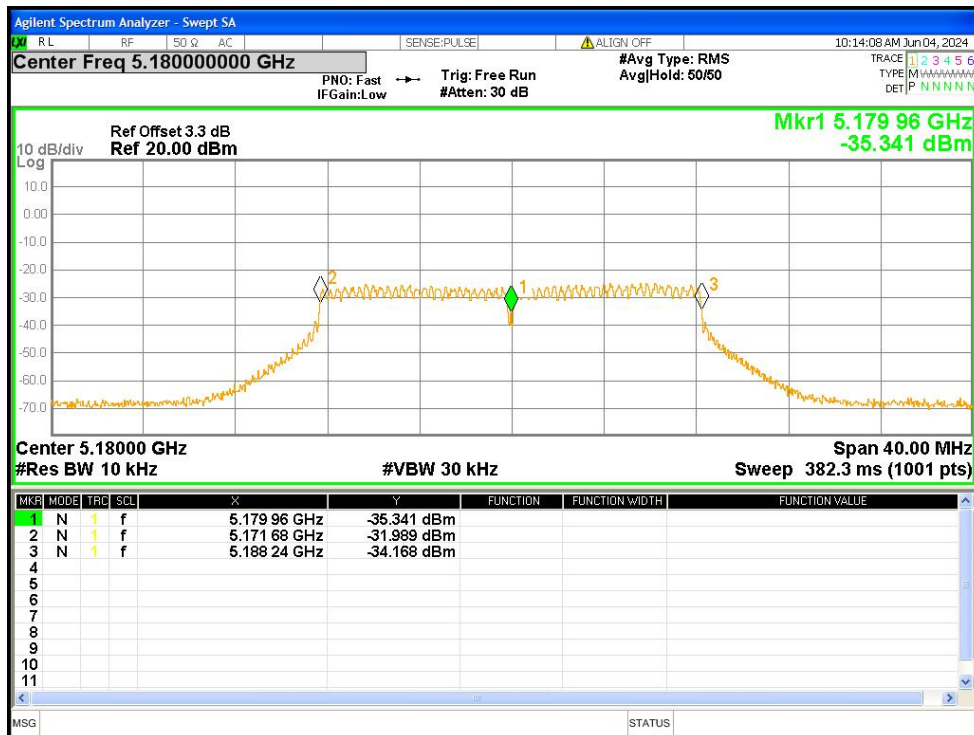

Freq. Stability NVNT a 5180MHz Ant1

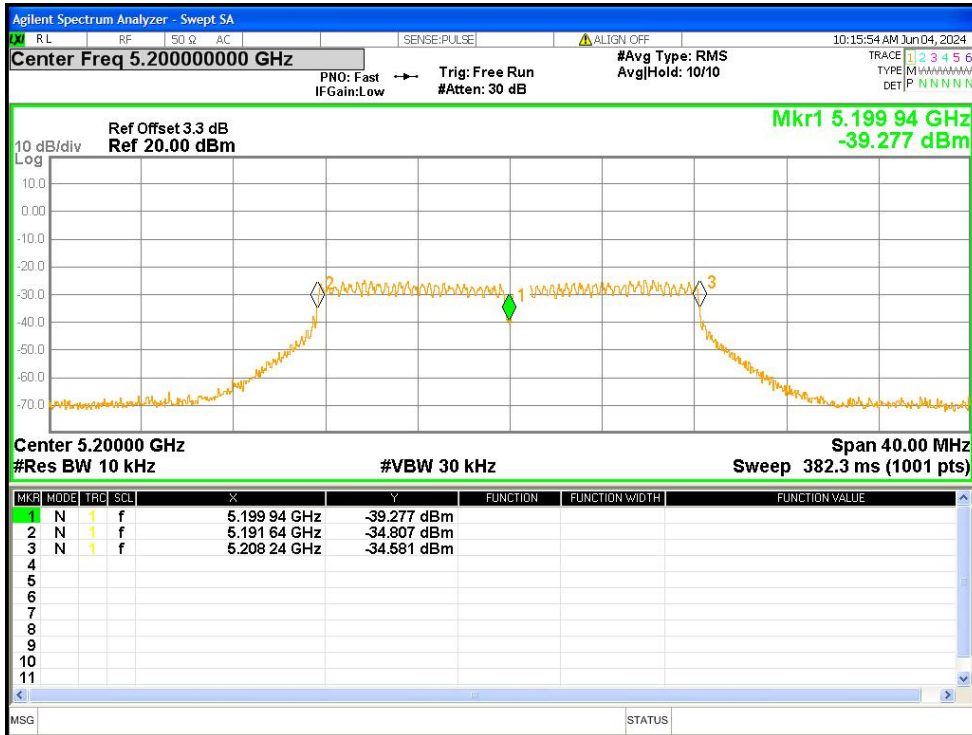

Freq. Stability NVNT a 5200MHz Ant1

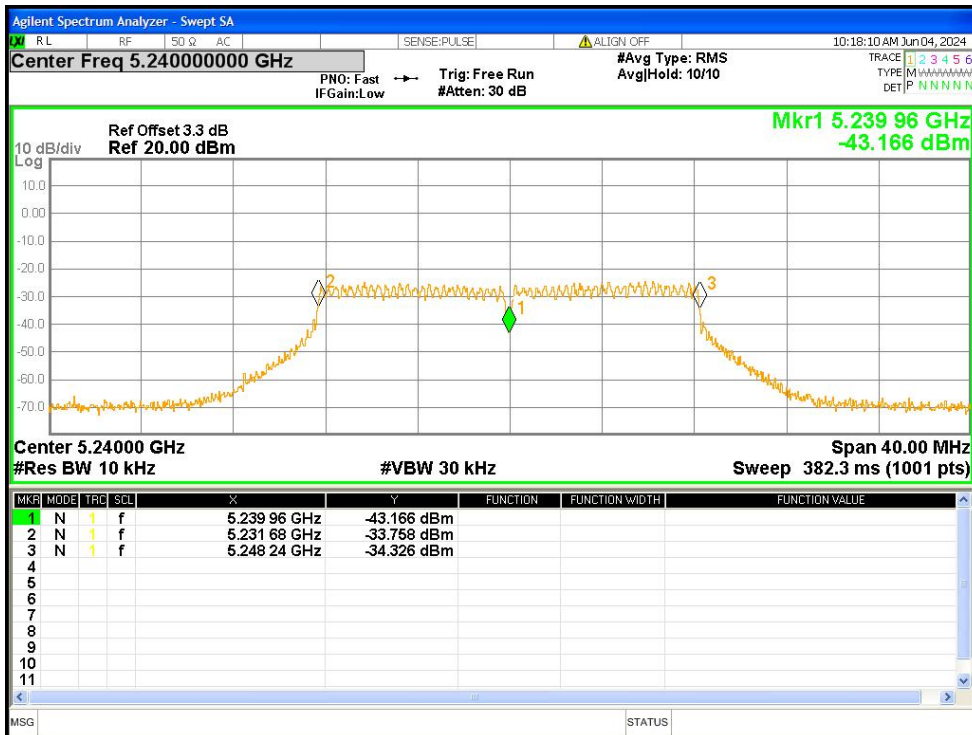

Freq. Stability NVNT a 5240MHz Ant1

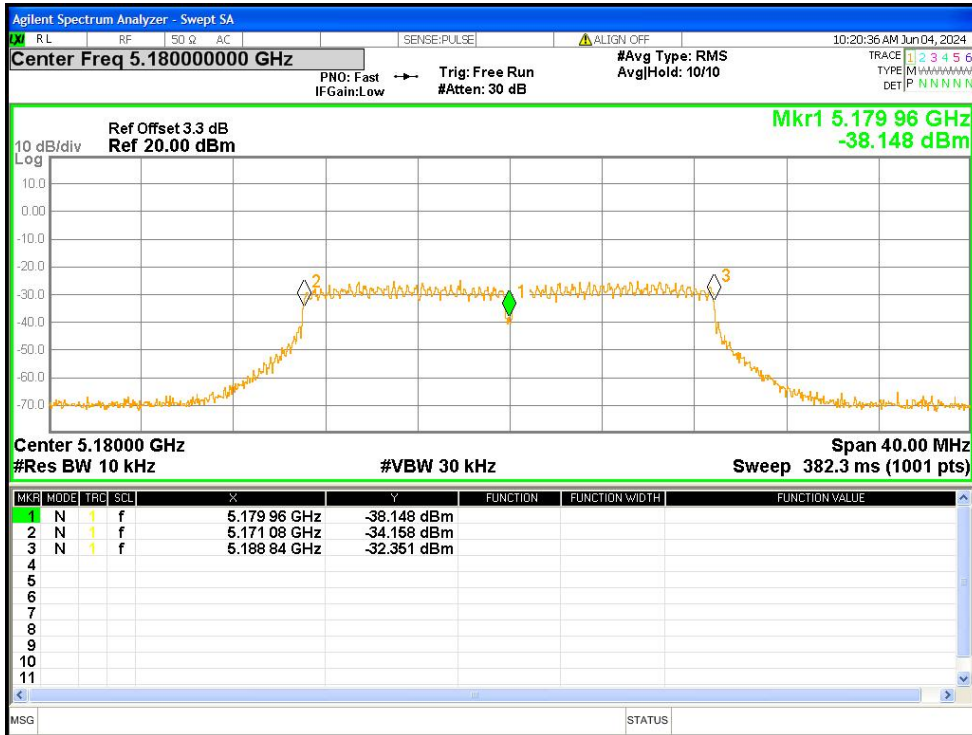

Freq. Stability NVNT n20 5180MHz Ant1

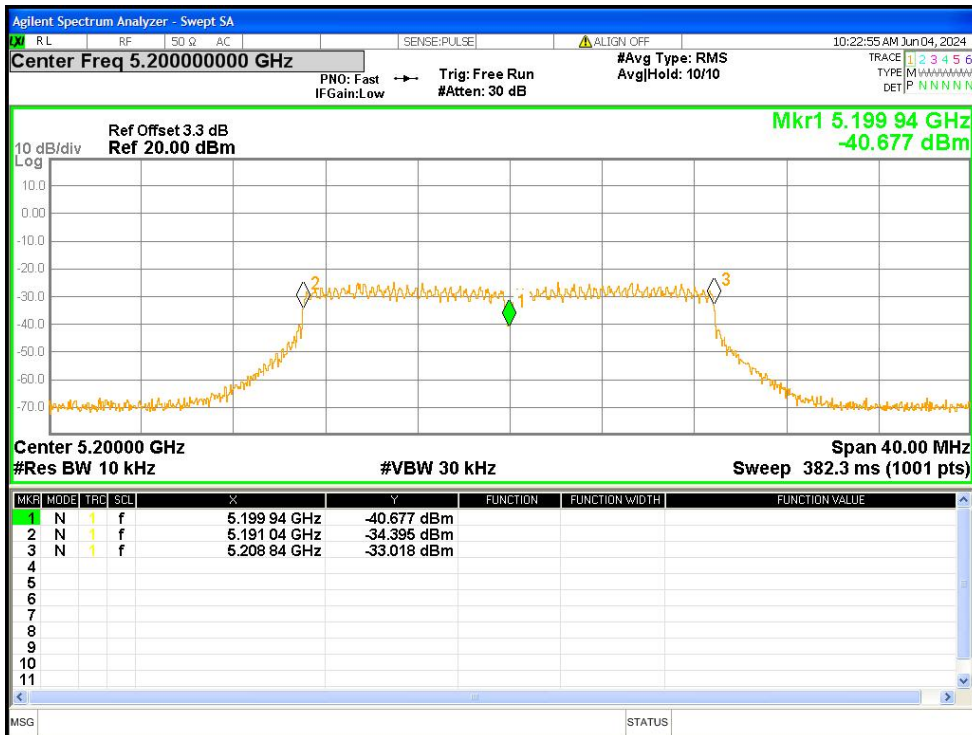

Freq. Stability NVNT n20 5200MHz Ant1

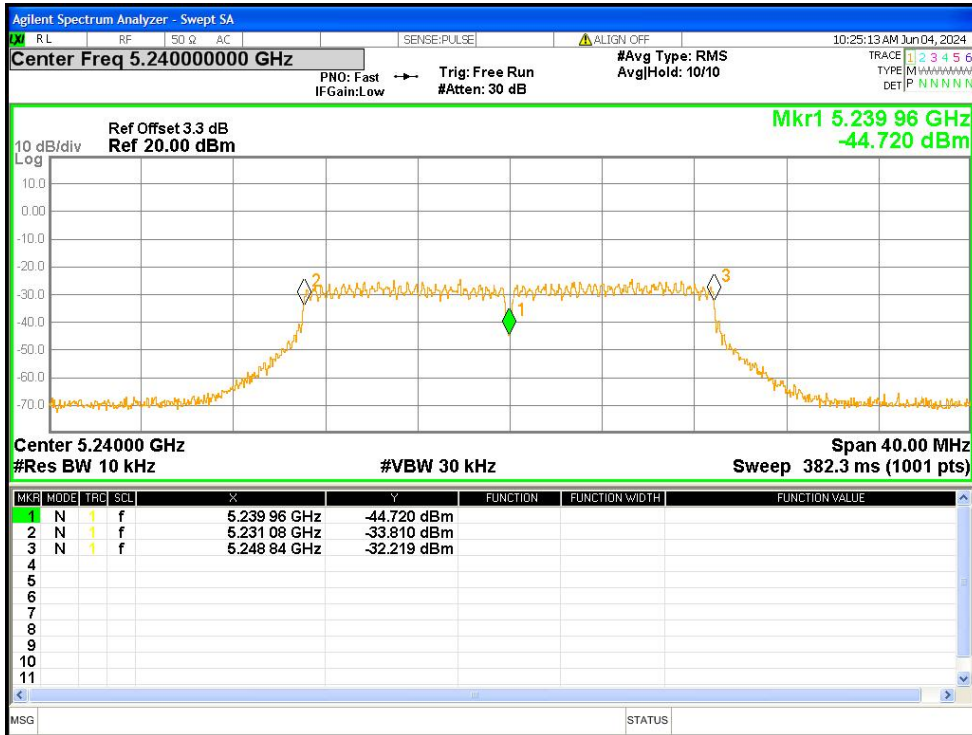

Freq. Stability NVNT n20 5240MHz Ant1

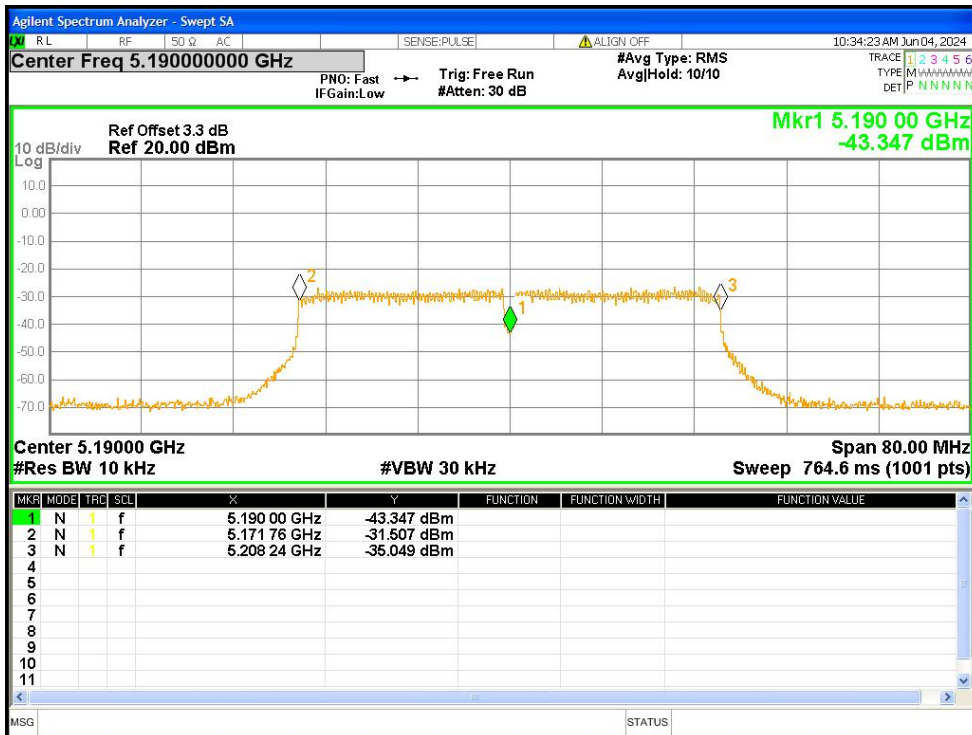

Freq. Stability NVNT n40 5190MHz Ant1

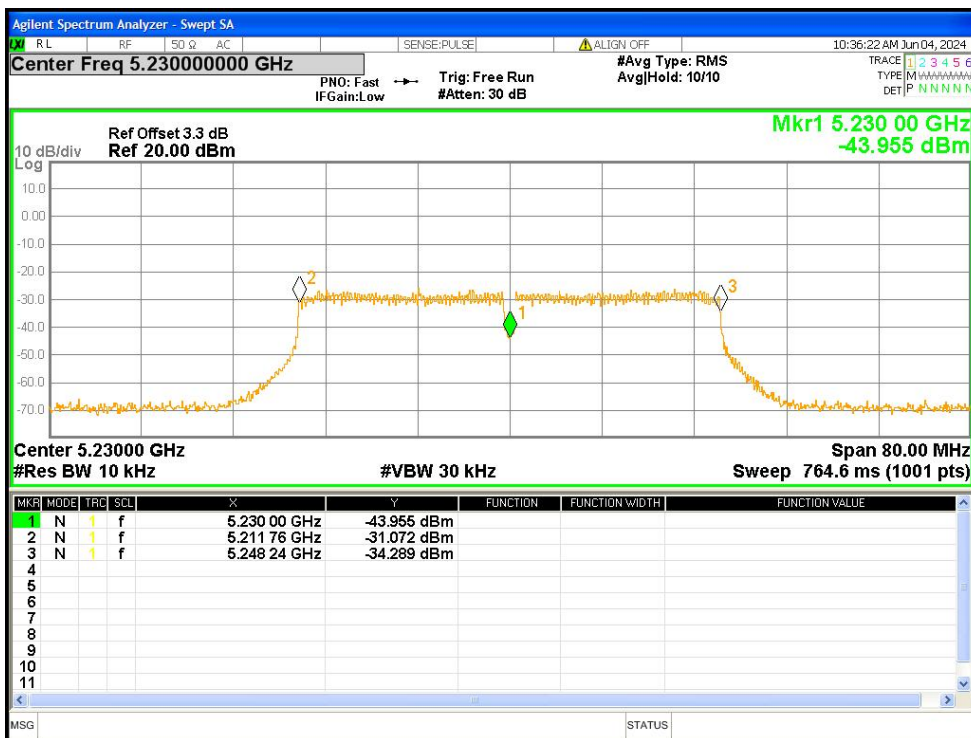

Freq. Stability NVNT n40 5230MHz Ant1

11. DUTY CYCLE

Test Requirement: 47 CFR Part 15E 15.407
KDB789033 D02 General U-NII Test Procedures New Rules v02r01,
Section (B)

Test Method: ANSI C63.10: 2013

Test Limit: N/A

Test Result: PASS

Remark: Through Pre-scan, The duty cycle set for channel low, middle and high are same, and the duty cycle test is performed at channel low only, The report only records the test data of antenna 1

Test Result:

Mode	Frequency (MHz)	Duty Cycle (%)	1/T (kHz)	Correction Factor (dB)
a	5180	100	0	0
a	5200	100	0	0
a	5240	100	0	0
n20	5180	100	0	0
n20	5200	100	0	0
n20	5240	100	0	0
n40	5190	100	0	0
n40	5230	100	0	0

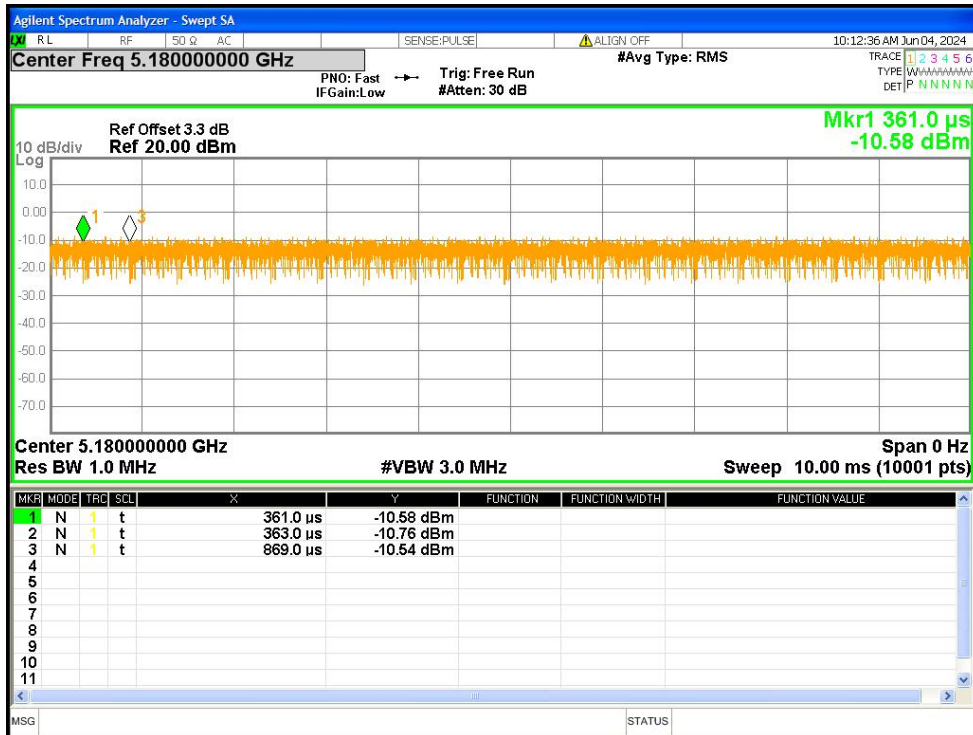

Duty Cycle NVNT a 5180MHz Ant1

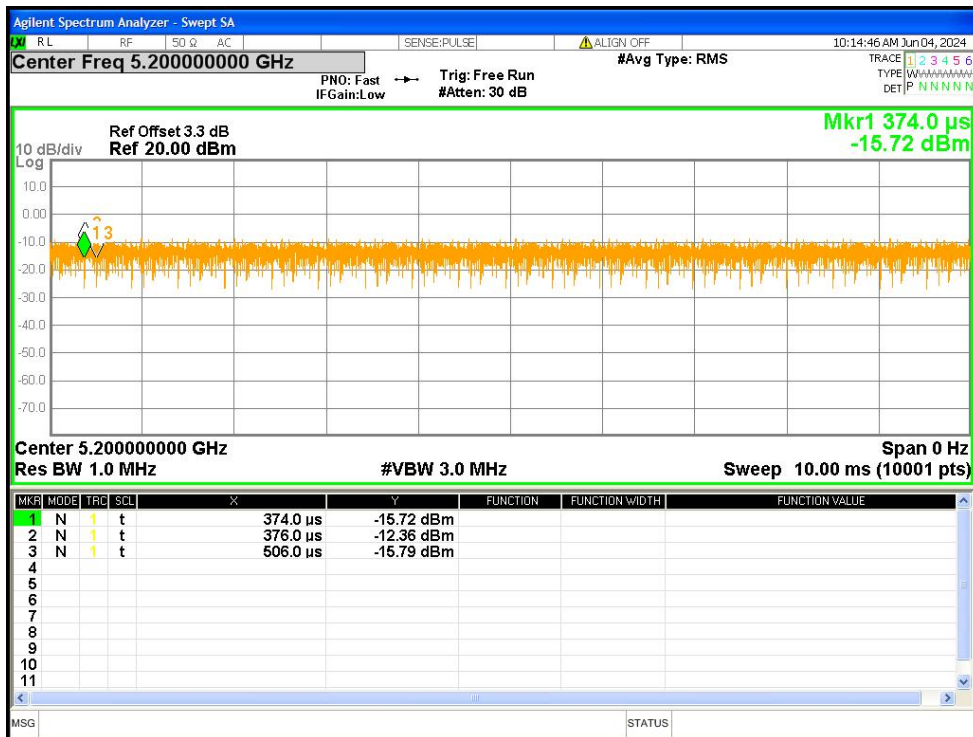

Duty Cycle NVNT a 5200MHz Ant1

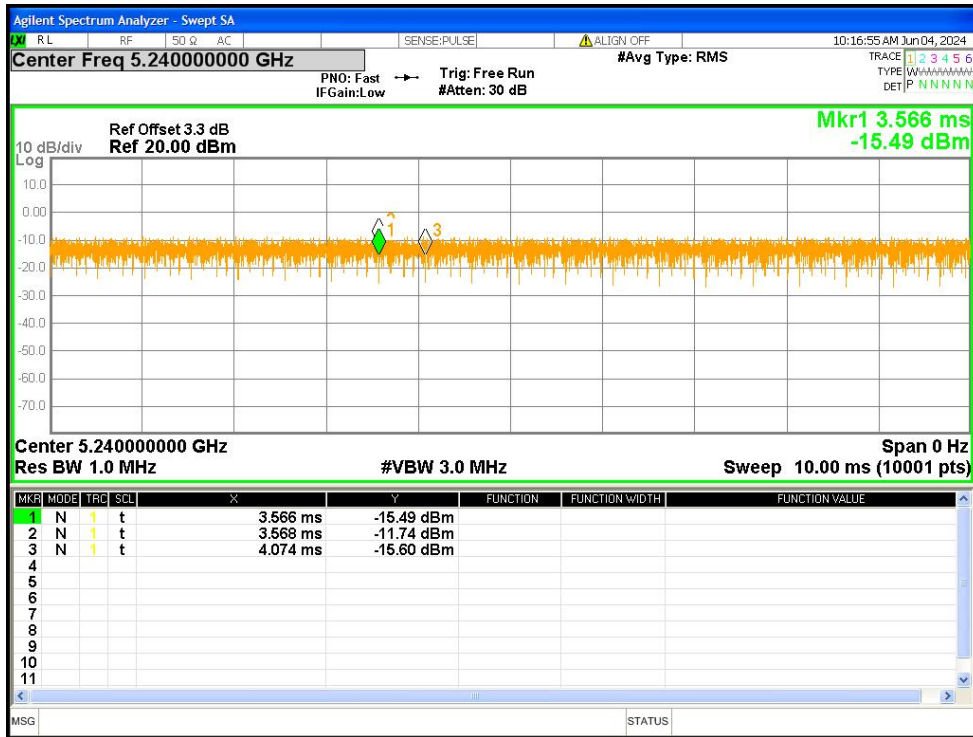

Duty Cycle NVNT a 5240MHz Ant1

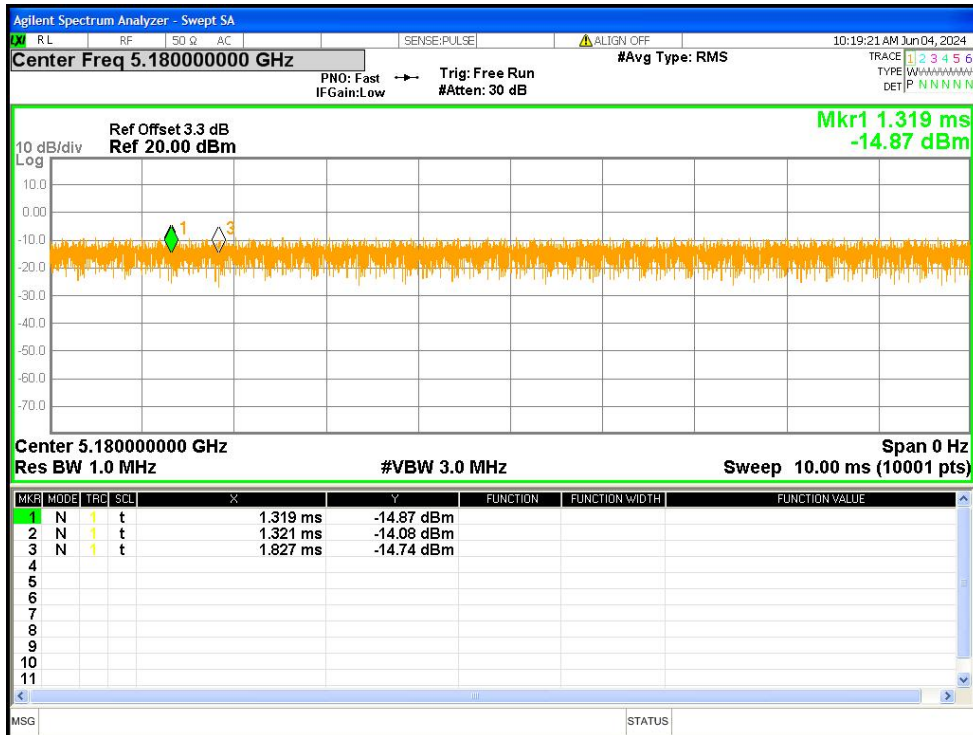

Duty Cycle NVNT n20 5180MHz Ant1

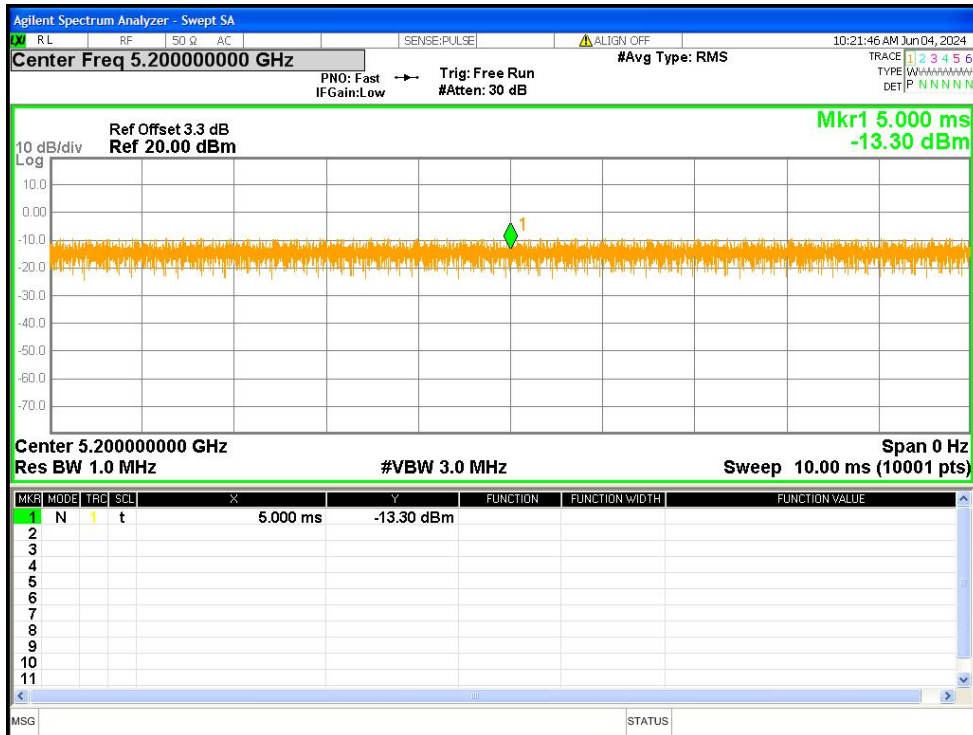

Duty Cycle NVNT n20 5200MHz Ant1

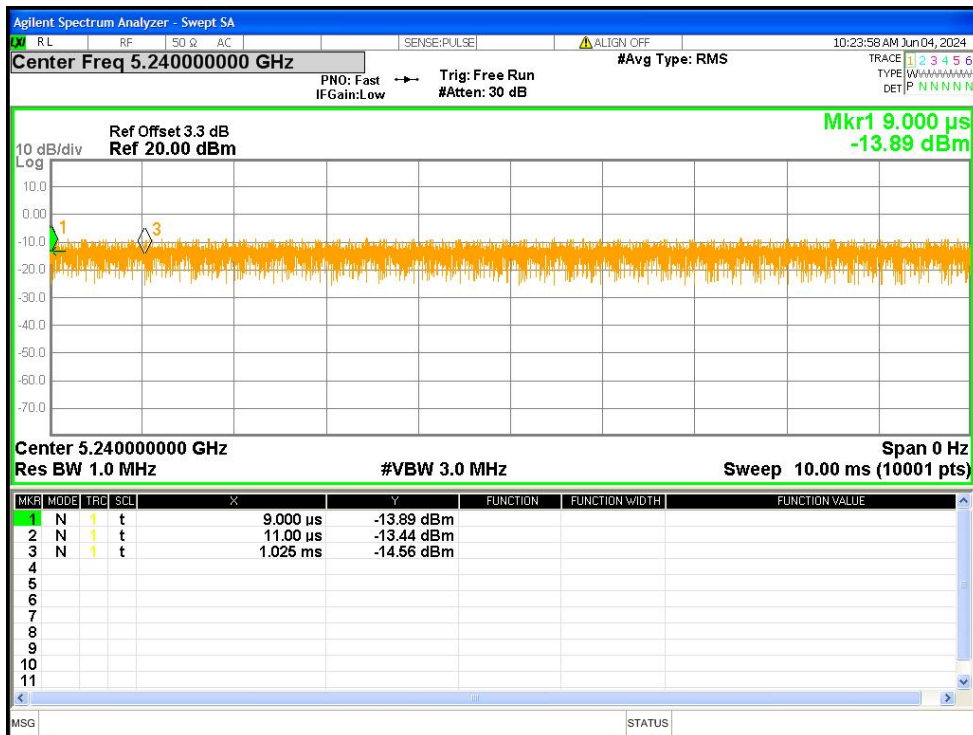

Duty Cycle NVNT n20 5240MHz Ant1

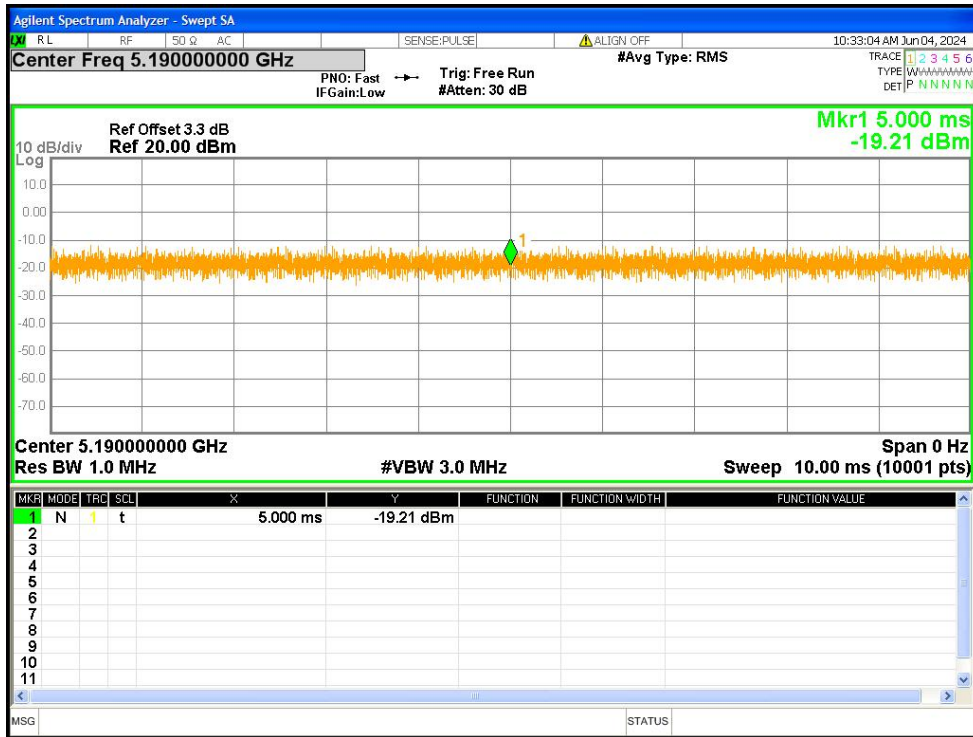

Duty Cycle NVNT n40 5190MHz Ant1

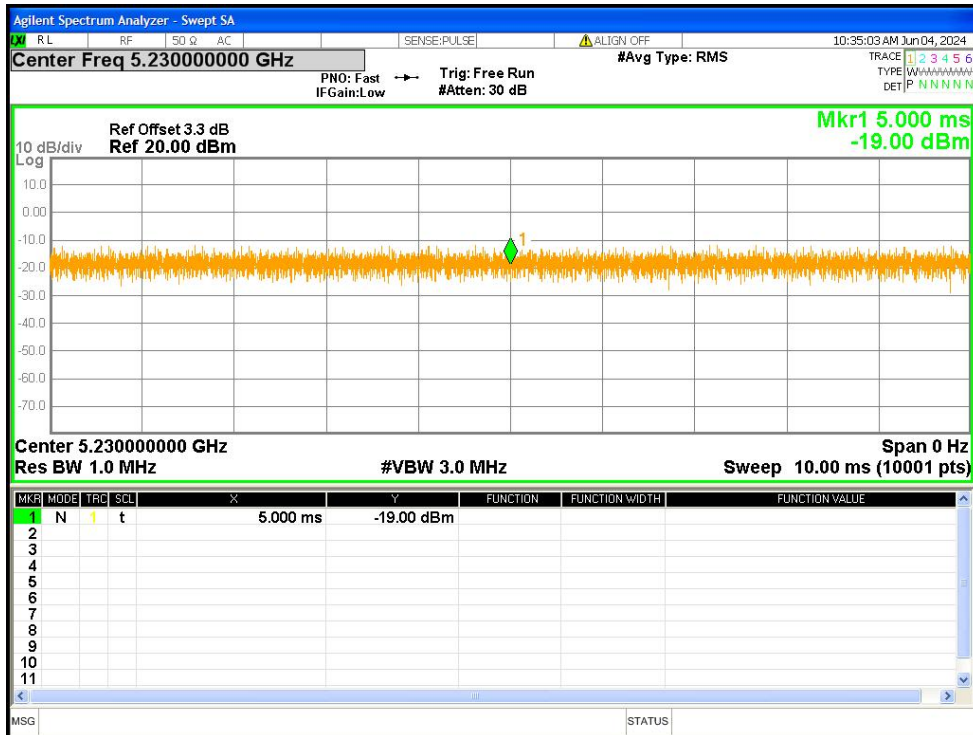

Duty Cycle NVNT n40 5230MHz Ant1

12.ANTENNA REQUIREMENT

Standard requirement:	FCC Section 15.203
<p>15.203 requirement: An intentional radiator shall be designed to ensure that no antenna other than that furnished by the responsible party shall be used with the device. The use of a permanently attached antenna or of an antenna that uses a unique coupling to the intentional radiator, the manufacturer may design the unit so that a broken antenna can be replaced by the user, but the use of a standard antenna jack or electrical connector is prohibited.</p> <p>RSS-Gen requirement: According to the RSS-Gen Section 6.8, an intentional radiator shall be designed to ensure that no antenna other than that furnished by the responsible party shall be used with the device.</p> <p>This device uses of Two antennas that uses a specified coupling to the intentional radiator. Antenna connectors complied with the requirement.</p>	
<p>EUT Antenna:</p>	
<p>The WIFI 5G antenna is a FPC antenna, the best case gain is 1.27dBi, reference to the appendixII fordetails</p>	

13. TEST SETUP PHOTO

Reference to the appendix I for details.

14. EUT CONSTRUCTIONAL DETAILS

Reference to the appendix II for details.

******* END OF REPORT *******