

# FCC Radio Test Report

## FCC ID: 2AL56GF-H100

### Original Grant

**Report No.** : TB-FCC153725  
**Applicant** : Shenzhen Goodflys Technology Co.,Ltd.  
**Equipment Under Test (EUT)**  
**EUT Name** : Smart Clock Camera  
**Model No.** : GF-H100base  
**Series Model No.** : GF-PH100pro, GF-PH100base, GF-PH100pro, GF-L100base, GF-L100pro, GF-T100base, GF-T100pro, GF-L200base, GF-L200pro  
**Brand Name** : Lizvie  
**Receipt Date** : 2017-05-02  
**Test Date** : 2017-05-03 to 2017-05-16  
**Issue Date** : 2017-05-17  
**Standards** : FCC Part 15, Subpart C (15.247:2016)  
**Test Method** : ANSI C63.10: 2013  
**Conclusions** : **PASS**

In the configuration tested, the EUT complied with the standards specified above,  
The EUT technically complies with the FCC and IC requirements

**Test/Witness Engineer** :

*Wan Su*

**Approved & Authorized** :

*Wan Su*



This report details the results of the testing carried out on one sample. The results contained in this test report do not relate to other samples of the same product. The manufacturer should ensure that all products in series production are in conformity with the product sample detailed in the report.

## Contents

<b>CONTENTS</b> .....	<b>2</b>
<b>1. GENERAL INFORMATION ABOUT EUT</b> .....	<b>4</b>
1.1 Client Information.....	4
1.2 General Description of EUT (Equipment Under Test) .....	4
1.3 Block Diagram Showing the Configuration of System Tested.....	5
1.4 Description of Support Units .....	5
1.5 Description of Test Mode.....	6
1.6 Description of Test Software Setting .....	7
1.7 Measurement Uncertainty .....	7
1.8 Test Facility.....	8
<b>2. TEST SUMMARY</b> .....	<b>9</b>
<b>3. TEST EQUIPMENT</b> .....	<b>10</b>
<b>4. CONDUCTED EMISSION TEST</b> .....	<b>11</b>
4.1 Test Standard and Limit.....	11
4.2 Test Setup.....	11
4.3 Test Procedure.....	11
4.4 EUT Operating Mode .....	12
4.5 Test Data.....	12
<b>5. RADIATED EMISSION TEST</b> .....	<b>17</b>
5.1 Test Standard and Limit.....	17
5.2 Test Setup.....	18
5.3 Test Procedure.....	19
5.4 EUT Operating Condition .....	19
5.5 Test Data.....	20
<b>6. RESTRICTED BANDS REQUIREMENT</b> .....	<b>47</b>
6.1 Test Standard and Limit.....	47
6.2 Test Setup.....	47
6.3 Test Procedure.....	47
6.4 EUT Operating Condition .....	48
6.5 Test Data.....	48
<b>7. BANDWIDTH TEST</b> .....	<b>69</b>
7.1 Test Standard and Limit.....	69
7.2 Test Setup.....	69
7.3 Test Procedure.....	69
7.4 EUT Operating Condition .....	69
7.5 Test Data.....	70
<b>8. PEAK OUTPUT POWER TEST</b> .....	<b>78</b>
8.1 Test Standard and Limit.....	78

8.2 Test Setup.....	78
8.3 Test Procedure.....	78
8.4 EUT Operating Condition .....	78
8.5 Test Data.....	79
<b>9. POWER SPECTRAL DENSITY TEST .....</b>	<b>82</b>
9.1 Test Standard and Limit.....	82
9.2 Test Setup.....	82
9.3 Test Procedure.....	82
9.4 EUT Operating Condition .....	82
9.5 Test Data.....	83
<b>10. ANTENNA REQUIREMENT.....</b>	<b>91</b>
10.1 Standard Requirement.....	91
10.2 Antenna Connected Construction.....	91

# 1. General Information about EUT

## 1.1 Client Information

**Applicant** : Shenzhen Goodflys Technology Co.,Ltd.  
**Address** : 308 Room 3th Floor Building A, Qinye Business Center, Xin an 6 Road, Xixiang Town, Baoan District, Shenzhen, Guangdong, China  
**Manufacturer** : Shenzhen Goodflys Technology Co.,Ltd.  
**Address** : 308 Room 3th Floor Building A, Qinye Business Center, Xin an 6 Road, Xixiang Town, Baoan District, Shenzhen, Guangdong, China

## 1.2 General Description of EUT (Equipment Under Test)

<b>EUT Name</b>	: Smart Clock Camera	
<b>Models No.</b>	: GF-H100base, GF-PH100pro, GF-PH100base, GF-PH100pro, GF-L100base, GF-L100pro, GF-T100base, GF-T100pro, GF-L200base, GF-L200pro	
<b>Model Difference</b>	: All these models are identical in the same PCB layout and electrical circuit, the only difference is model name for commercial.	
<b>Product Description</b>	Operation Frequency:	802.11b/g/n(HT20): 2412MHz~2462MHz 802.11n(HT40): 2422MHz~2452MHz
	Number of Channel:	802.11b/g/n(HT20):11 channels <i>see note(3)</i> 802.11n(HT40):9 channels <i>see note(3)</i>
	RF Output Power:	802.11b: 9.28 dBm 802.11g: 9.17 dBm 802.11n (HT20): 9.14 dBm 802.11n (HT40): 9.05 dBm
	Antenna Gain:	2 dBi Integral Antenna
	Modulation Type:	802.11b: DSSS(CCK, DQPSK, DBPSK) 802.11g/n:OFDM(BPSK,QPSK,16QAM, 64QAM)
	Bit Rate of Transmitter:	802.11b:11/5.5/2/1 Mbps 802.11g:54/48/36/24/18/12/9/6 Mbps 802.11n:up to 150Mbps
	<b>Power Supply</b>	: DC 5V by USB Cable. DC 3.6V by 9.0Wh Li-ion Battery.
<b>Connecting I/O Port(S)</b>	: Please refer to the User's Manual	

### Note:

- (1) This Test Report is FCC Part 15.247 for 802.11b/g/n, the test procedure follows the FCC KDB 558074 D01 DTS Meas Guidance v04.
- (2) For a more detailed features description, please refer to the manufacturer's specifications or

the User's Manual.

(3) Channel List:

Channel	Frequency (MHz)	Channel	Frequency (MHz)	Channel	Frequency (MHz)
01	2412	05	2432	09	2452
02	2417	06	2437	10	2457
03	2422	07	2442	11	2462
04	2427	08	2447		

Note:CH 01~CH 11 for 802.11b/g/n(HT20), CH 03~CH 09 for 802.11n(HT40)

(4) The Antenna information about the equipment is provided by the applicant.

### 1.3 Block Diagram Showing the Configuration of System Tested

#### USB Charging Mode

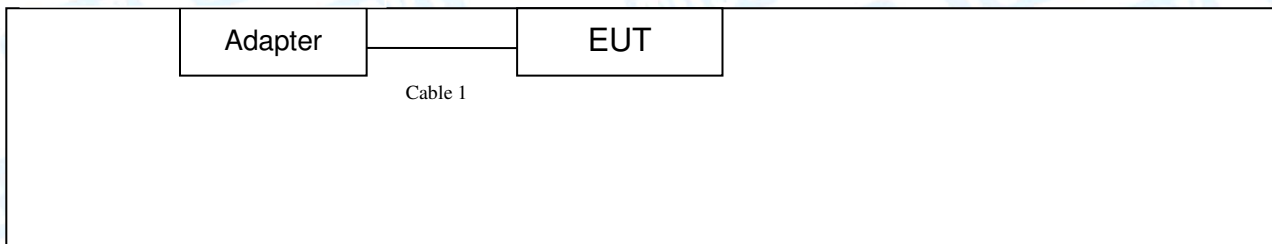

#### TX Mode

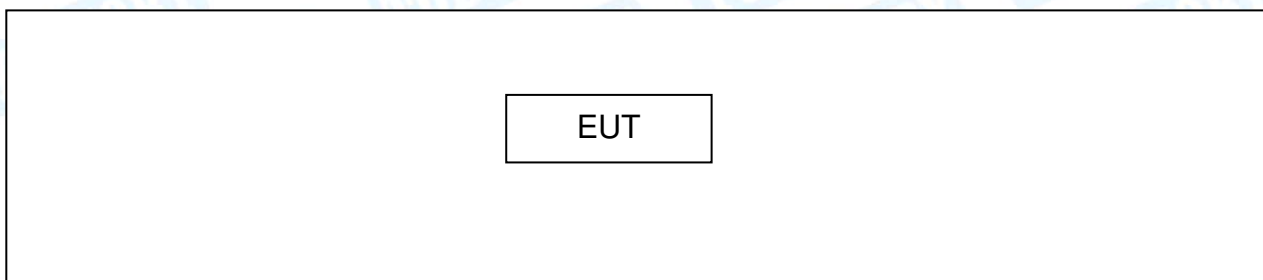

### 1.4 Description of Support Units

Equipment Information				
Name	Model	FCC ID/VOC	Manufacturer	Used “√”
AC/DC Adapter	TEKA012	VOC	TEKA	√
AC/DC Adapter: Input:100~240V, 50/60Hz, 0.2A. Output: 5V, 1A				
Cable Information				
Number	Shielded Type	Ferrite Core	Length	Note
Cable 1	YES	YES	1.2M	

## 1.5 Description of Test Mode

To investigate the maximum EMI emission characteristics generates from EUT, the test system was pre-scanning tested base on the consideration of following EUT operation mode or test configuration mode which possible have effect on EMI emission level. Each of these EUT operation mode(s) or test configuration mode(s) mentioned follow was evaluated respectively.

For Conducted Test	
Final Test Mode	Description
Mode 1	USB Charging with TX B Mode

For Radiated Test	
Final Test Mode	Description
Mode 2	TX Mode B Mode Channel 01/06/11
Mode 3	TX Mode G Mode Channel 01/06/11
Mode 4	TX Mode N(HT20) Mode Channel 01/06/11
Mode 5	TX Mode N(HT40) Mode Channel 03/06/09

**Note:**

- (1) For all test, we have verified the construction and function in typical operation. And all the test modes were carried out with the EUT in transmitting operation in maximum power with all kinds of data rate.  
According to ANSI C63.10 standards, the measurements are performed at the highest, Middle, lowest available channels, and the worst case data rate as follows:
  - 802.11b Mode: CCK (1 Mbps)
  - 802.11g Mode: OFDM (6 Mbps)
  - 802.11n (HT20) Mode: MCS 0 (6.5 Mbps)
  - 802.11n (HT40) Mode: MCS 0 (13 Mbps)
- (2) During the testing procedure, the continuously transmitting with the maximum power mode was programmed by the customer.
- (3) The EUT is considered a fixed unit; in normal use it was positioned on X-plane. The worst case was found positioned on X-plane. Therefore only the test data of this X-plane was used for radiated emission measurement test.

## 1.6 Description of Test Software Setting

During testing channel&Power controlling software provided by the customer was used to control the operating channel as well as the output power level. The RF output power selection is for the setting of RF output power expected by the customer and is going to be fixed on the firmware of the final end product power parameters of WLAN.

Test Software Version	MT7601USB.exe		
Channel	CH 01	CH 06	CH 11
IEEE 802.11b DSSS	DEF	DEF	DEF
IEEE 802.11g OFDM	DEF	DEF	DEF
IEEE 802.11n (HT20)	DEF	DEF	DEF
Channel	CH 03	CH 06	CH 09
IEEE 802.11n (HT40)	DEF	DEF	DEF

## 1.7 Measurement Uncertainty

The reported uncertainty of measurement  $y \pm U$ , where expanded uncertainty  $U$  is based on a standard uncertainty multiplied by a coverage factor of  $k=2$ , providing a level of confidence of approximately 95 %.

Test Item	Parameters	Expanded Uncertainty ( $U_{Lab}$ )
Conducted Emission	Level Accuracy: 9kHz~150kHz 150kHz to 30MHz	$\pm 3.42$ dB $\pm 3.42$ dB
Radiated Emission	Level Accuracy: 9kHz to 30 MHz	$\pm 4.60$ dB
Radiated Emission	Level Accuracy: 30MHz to 1000 MHz	$\pm 4.40$ dB
Radiated Emission	Level Accuracy: Above 1000MHz	$\pm 4.20$ dB

## 1.8 Test Facility

The testing report were performed by the Shenzhen Toby Technology Co., Ltd., in their facilities located at 1A/F., Bldg.6, Yusheng Industrial Zone, The National Road No.107 Xixiang Section 467, Xixiang, Bao'an, Shenzhen, Guangdong, China. At the time of testing, the following bodies accredited the Laboratory:

### **CNAS (L5813)**

The Laboratory has been accredited by CNAS to ISO/IEC 17025: 2005 General Requirements for the Competence of Testing and Calibration Laboratories for the competence in the field of testing. And the Registration No.: CNAS L5813.

### **FCC List No.: (811562)**

The Laboratory is listed in the United States of American Federal Communications Commission (FCC), and the registration number is 811562.

### **IC Registration No.: (11950A-1)**

The Laboratory has been registered by Certification and Engineering Bureau of Industry Canada for radio equipment testing. The site registration: Site# 11950A-1.

## 2. Test Summary

FCC Part 15 Subpart C(15.247)/ RSS 247 Issue 1				
Standard Section		Test Item	Judgment	Remark
FCC	IC			
15.203	/	Antenna Requirement	PASS	N/A
15.207	RSS-GEN 7.2.4	Conducted Emission	PASS	N/A
15.205	RSS-GEN 7.2.2	Restricted Bands	PASS	N/A
15.247(a)(2)	RSS 247 5.2 (1)	6dB Bandwidth	PASS	N/A
15.247(b)	RSS 247 5.4 (4)	Peak Output Power	PASS	N/A
15.247(e)	RSS 247 5.2 (2)	Power Spectral Density	PASS	N/A
15.247(d)	RSS 247 5.5	Band Edge	PASS	N/A
15.247(d)& 15.209	RSS 247 5.5	Transmitter Radiated Spurious Emission	PASS	N/A

**Note:** “/” for no requirement for this test item.  
N/A is an abbreviation for Not Applicable.

### 3. Test Equipment

Conducted Emission Test					
Equipment	Manufacturer	Model No.	Serial No.	Last Cal.	Cal. Due Date
EMI Test Receiver	Rohde & Schwarz	ESCI	100321	Jul. 22, 2016	Jul. 21, 2017
RF Switching Unit	Compliance Direction Systems Inc	RSU-A4	34403	Jul. 22, 2016	Jul. 21, 2017
AMN	SCHWARZBECK	NNBL 8226-2	8226-2/164	Jul. 22, 2016	Jul. 21, 2017
LISN	Rohde & Schwarz	ENV216	101131	Jul. 22, 2016	Jul. 21, 2017
Radiation Emission Test					
Equipment	Manufacturer	Model No.	Serial No.	Last Cal.	Cal. Due Date
Spectrum Analyzer	Agilent	E4407B	MY45106456	Jul. 22, 2016	Jul. 21, 2017
EMI Test Receiver	Rohde & Schwarz	ESPI	100010/007	Jul. 22, 2016	Jul. 21, 2017
Bilog Antenna	ETS-LINDGREN	3142E	00117537	Mar.25, 2017	Mar. 24, 2018
Bilog Antenna	ETS-LINDGREN	3142E	00117542	Mar.25, 2017	Mar. 24, 2018
Horn Antenna	ETS-LINDGREN	3117	00143207	Mar.24, 2017	Mar. 23, 2018
Horn Antenna	ETS-LINDGREN	3117	00143209	Mar.24, 2017	Mar. 23, 2018
Loop Antenna	Laplace instrument	RF300	0701	Mar.24, 2017	Mar. 23, 2018
Pre-amplifier	Sonoma	310N	185903	Mar.25, 2017	Mar. 24, 2018
Pre-amplifier	HP	8449B	3008A00849	Mar.26, 2016	Mar. 25, 2017
Cable	HUBER+SUHNER	100	SUCOFLEX	Mar.26, 2016	Mar. 25, 2017
Positioning Controller	ETS-LINDGREN	2090	N/A	N/A	N/A
Antenna Conducted Emission					
Equipment	Manufacturer	Model No.	Serial No.	Last Cal.	Cal. Due Date
Spectrum Analyzer	Agilent	E4407B	MY45106456	Jul. 22, 2016	Jul. 21, 2017
Spectrum Analyzer	Rohde & Schwarz	ESCI	100010/007	Jul. 22, 2016	Jul. 21, 2017
Power Meter	Anritsu	ML2495A	25406005	Jul. 22, 2016	Jul. 21, 2017
Power Sensor	Anritsu	ML2411B	25406005	Jul. 22, 2016	Jul. 21, 2017

## 4. Conducted Emission Test

### 4.1 Test Standard and Limit

#### 4.1.1 Test Standard

FCC Part 15.207

#### 4.1.2 Test Limit

**Conducted Emission Test Limit**

Frequency	Maximum RF Line Voltage (dB $\mu$ V)	
	Quasi-peak Level	Average Level
150kHz~500kHz	66 ~ 56 *	56 ~ 46 *
500kHz~5MHz	56	46
5MHz~30MHz	60	50

Notes:

(1) \*Decreasing linearly with logarithm of the frequency.

(2) The lower limit shall apply at the transition frequencies.

(3) The limit decrease in line with the logarithm of the frequency in the range of 0.15 to 0.50MHz.

### 4.2 Test Setup

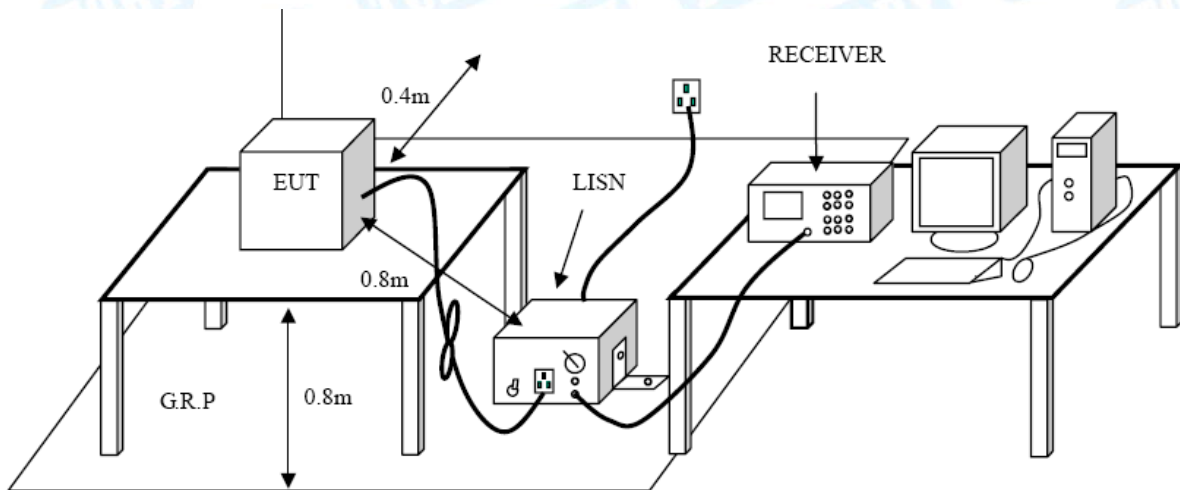

### 4.3 Test Procedure

The EUT was placed 0.8 meters from the horizontal ground plane with EUT being connected to the power mains through a line impedance stabilization network (LISN). All other support equipments powered from additional LISN(s). The LISN provide 50 Ohm/ 50uH of coupling impedance for the measuring instrument.

Interconnecting cables that hang closer than 40 cm to the ground plane shall be folded back and forth in the center forming a bundle 30 to 40 cm long.

I/O cables that are not connected to a peripheral shall be bundled in the center. The end of the cable may be terminated, if required, using the correct terminating impedance. The overall length shall not exceed 1 m.

LISN at least 80 cm from nearest part of EUT chassis.

The bandwidth of EMI test receiver is set at 9kHz, and the test frequency band is from 0.15MHz to 30MHz.

#### 4.4 EUT Operating Mode

Please refer to the description of test mode.

#### 4.5 Test Data

Please see the next page.

<b>EUT:</b>	Smart Clock Camera	<b>Model Name :</b>	GF-H100base
<b>Temperature:</b>	25 °C	<b>Relative Humidity:</b>	55%
<b>Test Voltage:</b>	AC 120V/60Hz		
<b>Terminal:</b>	Line		
<b>Test Mode:</b>	Charging with TX B Mode		
<b>Remark:</b>	Only worse case is reported		

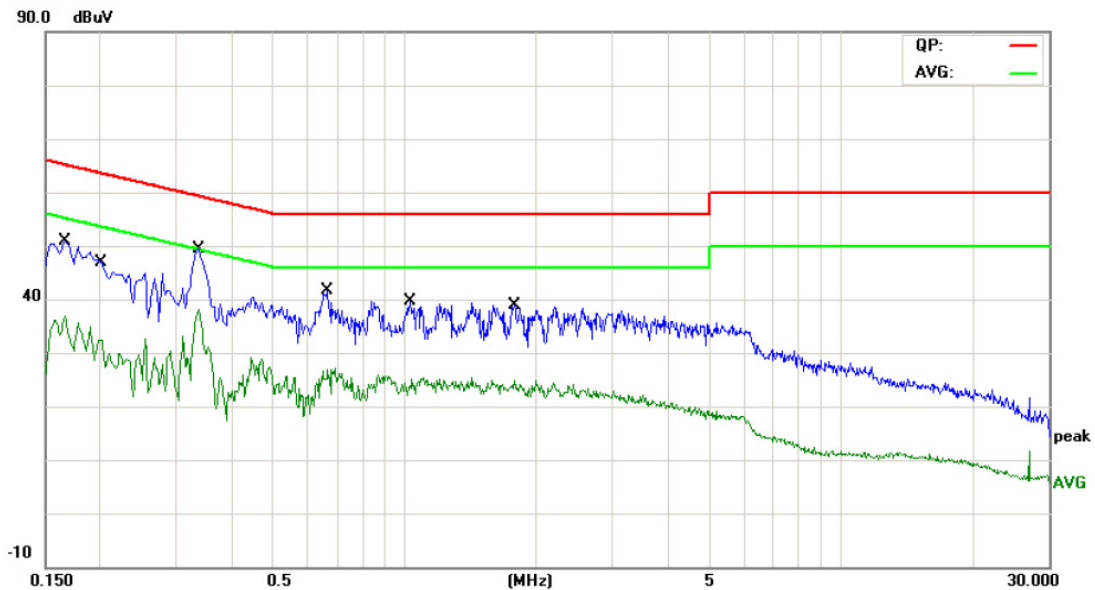

No.	Mk.	Freq. MHz	Reading Level dBuV	Correct Factor dB	Measure- ment dBuV	Limit dBuV	Over dB	Detector
1		0.1660	36.29	9.95	46.24	65.15	-18.91	QP
2		0.1660	18.61	9.95	28.56	55.15	-26.59	AVG
3		0.2029	31.70	10.02	41.72	63.49	-21.77	QP
4		0.2029	16.55	10.02	26.57	53.49	-26.92	AVG
5		0.3379	36.26	10.02	46.28	59.25	-12.97	QP
6	*	0.3379	26.62	10.02	36.64	49.25	-12.61	AVG
7		0.6660	26.96	10.10	37.06	56.00	-18.94	QP
8		0.6660	16.21	10.10	26.31	46.00	-19.69	AVG
9		1.0300	24.13	10.06	34.19	56.00	-21.81	QP
10		1.0300	13.39	10.06	23.45	46.00	-22.55	AVG
11		1.7900	22.81	10.06	32.87	56.00	-23.13	QP
12		1.7900	13.84	10.06	23.90	46.00	-22.10	AVG

Emission Level= Read Level+ Correct Factor

<b>EUT:</b>	Smart Clock Camera	<b>Model Name :</b>	GF-H100base
<b>Temperature:</b>	25 °C	<b>Relative Humidity:</b>	55%
<b>Test Voltage:</b>	AC 120V/60Hz		
<b>Terminal:</b>	Neutral		
<b>Test Mode:</b>	Charging with TX B Mode		
<b>Remark:</b>	Only worse case is reported		

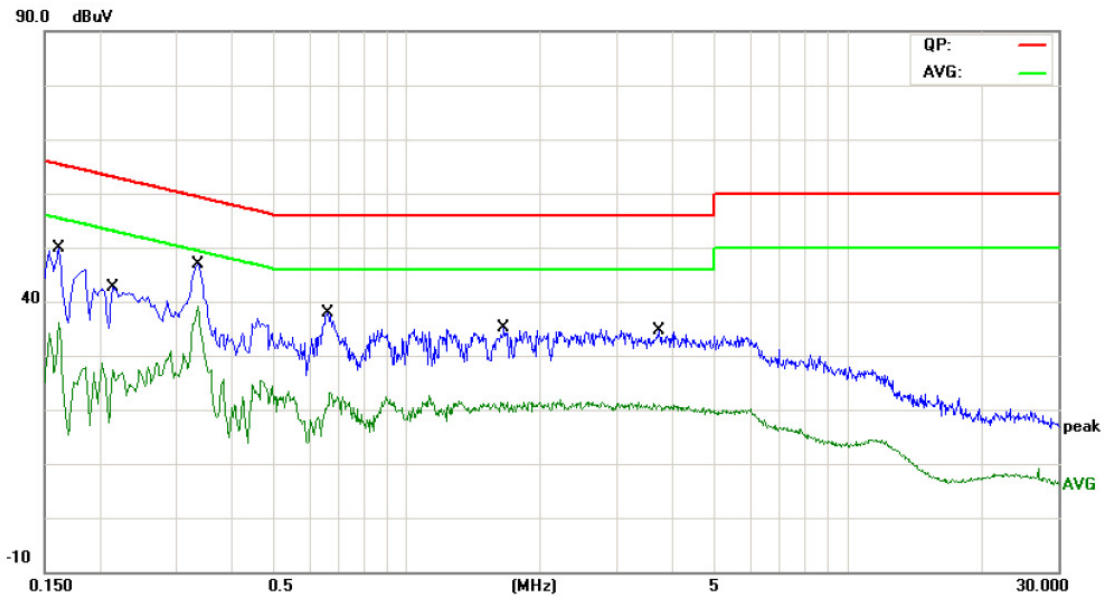

No.	Mk.	Freq. MHz	Reading Level dBuV	Correct Factor dB	Measure- ment dBuV	Limit dBuV	Over dB	Detector
1		0.1620	34.10	10.12	44.22	65.36	-21.14	QP
2		0.1620	19.35	10.12	29.47	55.36	-25.89	AVG
3		0.2140	27.65	10.12	37.77	63.04	-25.27	QP
4		0.2140	10.89	10.12	21.01	53.04	-32.03	AVG
5		0.3339	34.27	10.08	44.35	59.35	-15.00	QP
6	*	0.3339	27.52	10.08	37.60	49.35	-11.75	AVG
7		0.6580	23.51	10.02	33.53	56.00	-22.47	QP
8		0.6580	9.84	10.02	19.86	46.00	-26.14	AVG
9		1.6540	19.63	10.09	29.72	56.00	-26.28	QP
10		1.6540	10.14	10.09	20.23	46.00	-25.77	AVG
11		3.7380	16.85	10.06	26.91	56.00	-29.09	QP
12		3.7380	9.76	10.06	19.82	46.00	-26.18	AVG

Emission Level= Read Level+ Correct Factor

<b>EUT:</b>	Smart Clock Camera	<b>Model Name :</b>	GF-H100base
<b>Temperature:</b>	25 °C	<b>Relative Humidity:</b>	55%
<b>Test Voltage:</b>	AC 240V/60Hz		
<b>Terminal:</b>	Line		
<b>Test Mode:</b>	Charging with TX B Mode		
<b>Remark:</b>	Only worse case is reported		

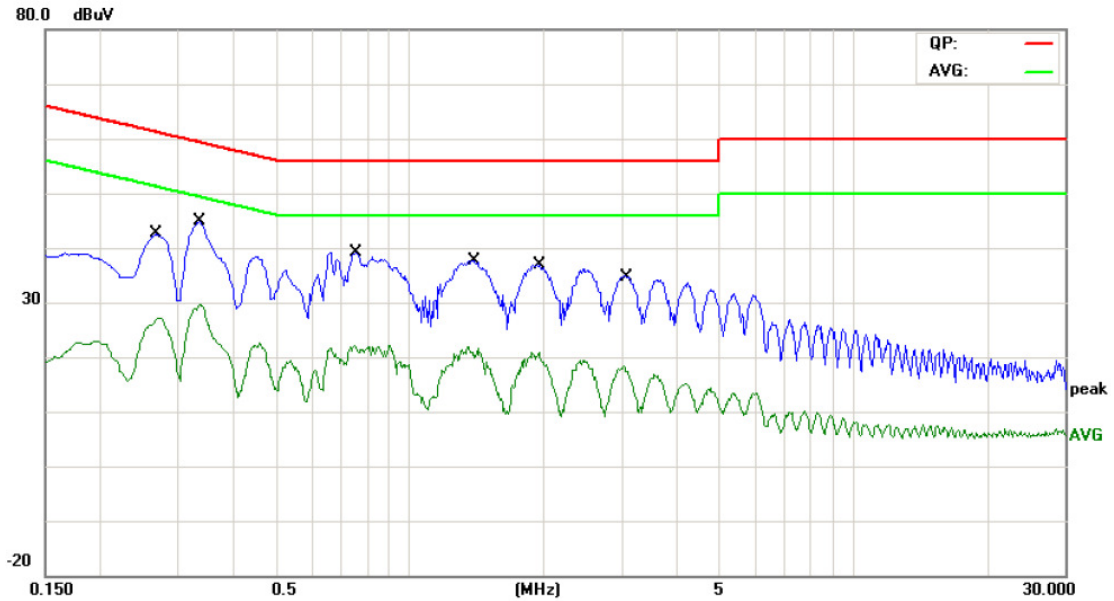

No.	Mk.	Freq. MHz	Reading Level dBuV	Correct Factor dB	Measure- ment dBuV	Limit dBuV	Over dB	Detector
1		0.2660	26.76	10.02	36.78	61.24	-24.46	QP
2		0.2660	15.99	10.02	26.01	51.24	-25.23	AVG
3	*	0.3339	29.83	10.02	39.85	59.35	-19.50	QP
4		0.3339	18.76	10.02	28.78	49.35	-20.57	AVG
5		0.7539	23.38	10.11	33.49	56.00	-22.51	QP
6		0.7539	10.71	10.11	20.82	46.00	-25.18	AVG
7		1.4020	21.63	10.06	31.69	56.00	-24.31	QP
8		1.4020	9.25	10.06	19.31	46.00	-26.69	AVG
9		1.9540	21.35	10.06	31.41	56.00	-24.59	QP
10		1.9540	9.65	10.06	19.71	46.00	-26.29	AVG
11		3.1260	18.73	10.02	28.75	56.00	-27.25	QP
12		3.1260	5.30	10.02	15.32	46.00	-30.68	AVG

Emission Level= Read Level+ Correct Factor

<b>EUT:</b>	Smart Clock Camera	<b>Model Name :</b>	GF-H100base
<b>Temperature:</b>	25 °C	<b>Relative Humidity:</b>	55%
<b>Test Voltage:</b>	AC 240V/60Hz		
<b>Terminal:</b>	Neutral		
<b>Test Mode:</b>	Charging with TX B Mode		
<b>Remark:</b>	Only worse case is reported		

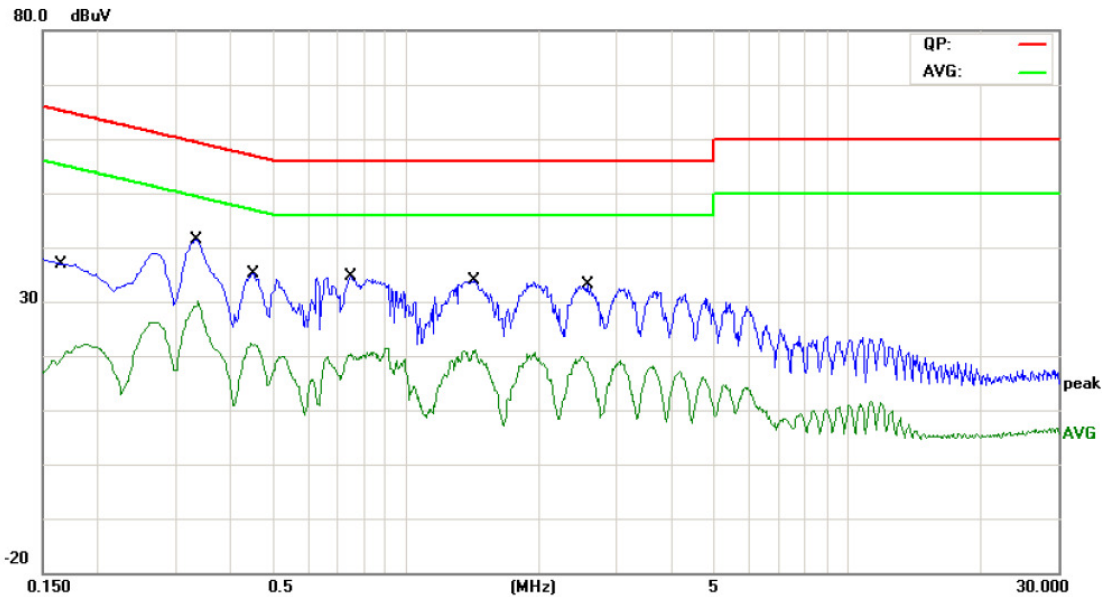

No.	Mk.	Freq.	Reading Level	Correct Factor	Measurement	Limit	Over	Detector
		MHz	dBuV	dB	dBuV	dBuV	dB	
1		0.1676	21.44	10.12	31.56	65.07	-33.51	QP
2		0.1676	9.76	10.12	19.88	55.07	-35.19	AVG
3		0.3339	26.68	10.08	36.76	59.35	-22.59	QP
4	*	0.3339	19.28	10.08	29.36	49.35	-19.99	AVG
5		0.4500	19.17	10.04	29.21	56.87	-27.66	QP
6		0.4500	11.85	10.04	21.89	46.87	-24.98	AVG
7		0.7500	18.73	10.04	28.77	56.00	-27.23	QP
8		0.7500	9.77	10.04	19.81	46.00	-26.19	AVG
9		1.4220	17.89	10.12	28.01	56.00	-27.99	QP
10		1.4220	10.63	10.12	20.75	46.00	-25.25	AVG
11		2.5740	16.51	10.06	26.57	56.00	-29.43	QP
12		2.5740	8.16	10.06	18.22	46.00	-27.78	AVG

Emission Level= Read Level+ Correct Factor

## 5. Radiated Emission Test

### 5.1 Test Standard and Limit

#### 5.1.1 Test Standard

FCC Part 15.209

#### 5.1.2 Test Limit

#### Radiated Emission Limits ( 9 kHz~1000 MHz)

Frequency (MHz)	Field Strength (microvolt/meter)	Measurement Distance (meters)
0.009~0.490	2400/F(KHz)	300
0.490~1.705	24000/F(KHz)	30
1.705~30.0	30	30
30~88	100	3
88~216	150	3
216~960	200	3
Above 960	500	3

#### Radiated Emission Limit (Above 1000MHz)

Frequency (MHz)	Distance of 3m (dBuV/m)	
	Peak	Average
Above 1000	74	54

**Note:**

- (1) The tighter limit applies at the band edges.
- (2) Emission Level(dBuV/m)=20log Emission Level(uV/m)

5.2 Test Setup

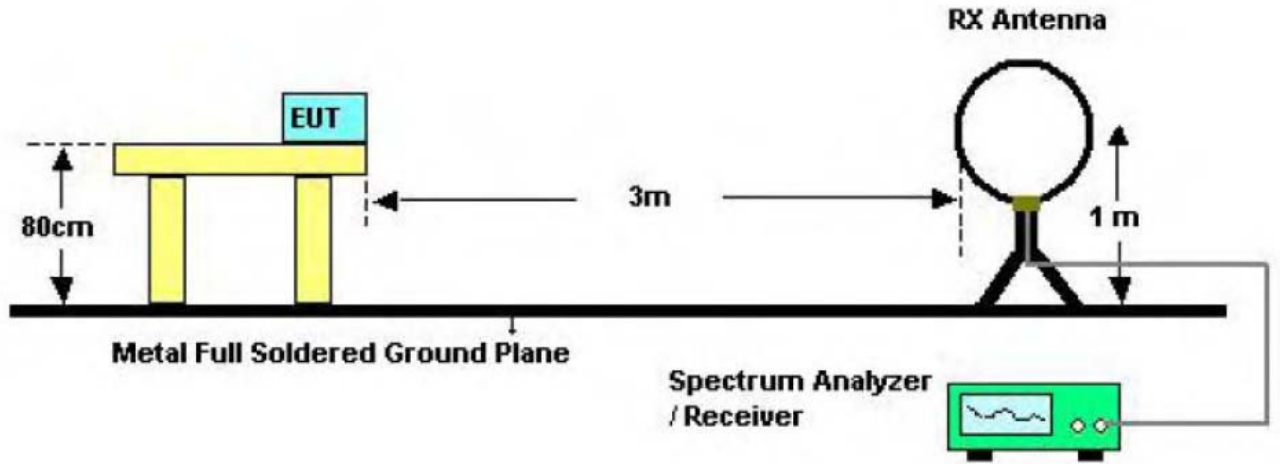

Below 30MHz Test Setup

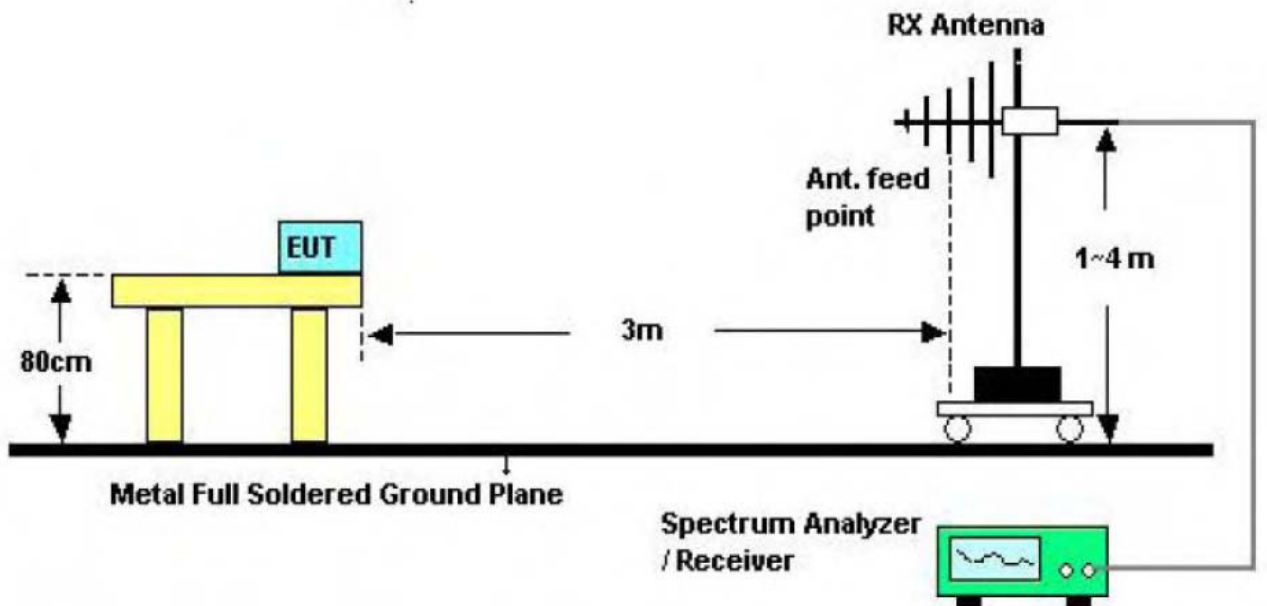

Below 1000MHz Test Setup

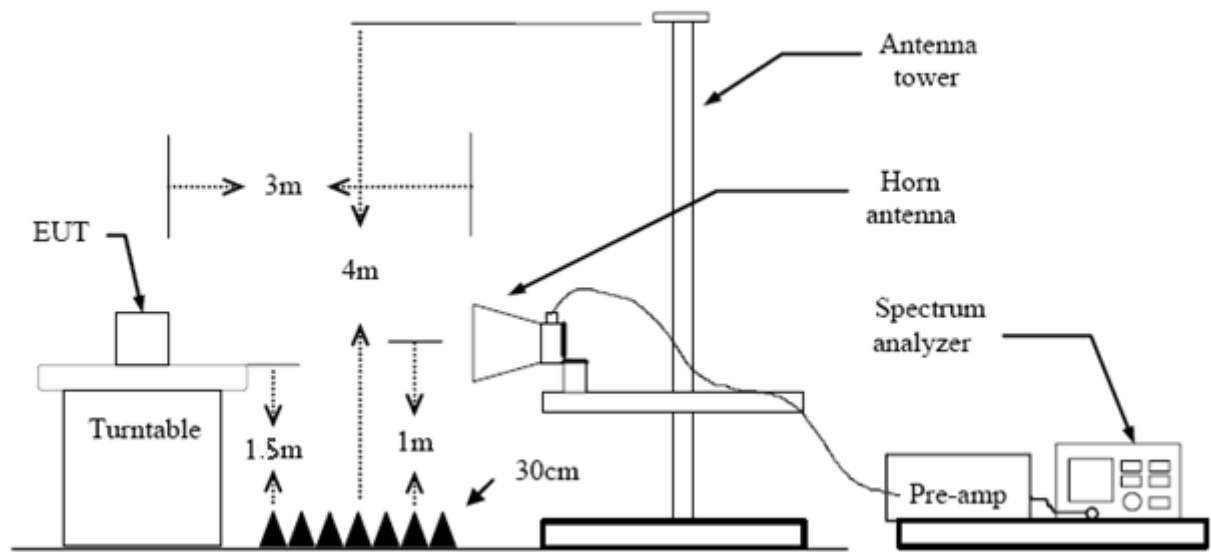

Above 1GHz Test Setup

### 5.3 Test Procedure

- (1) Measurements at frequency above 1GHz. The EUT was placed on a rotating 1.5m high above the ground. RF absorbers covered the ground plane with a minimum area of 3.0m by 3.0m between the EUT and measurement receiver antenna. The RF absorber shall not exceed 30cm in high above the conducting floor. The table was rotated 360 degrees to determine the position of the highest radiation.
- (2) The Test antenna shall vary between 1m and 4m, Both Horizontal and Vertical antenna are set to make measurement.
- (3) The initial step in collecting conducted emission data is a spectrum analyzer peak detector mode pre-scanning the measurement frequency range. Significant peaks are then marked and then Quasi Peak detector mode re-measured.
- (4) If the Peak Mode measured value compliance with and lower than Quasi Peak Mode Limit Bellow 1 GHz, the EUT shall be deemed to meet QP Limits and then no additional QP Mode measurement performed. But the Peak Value and average value both need to comply with applicable limit above 1 GHz.
- (5) Testing frequency range below 1GHz the measuring instrument use VBW=120 kHz with Quasi-peak detection.
- (6) Testing frequency range above 1GHz the measuring instrument use RBW=1 MHz and VBW=3 MHz with Peak Detector for Peak Values, and use RBW=1 MHz and VBW=10 Hz with Peak Detector for Average Values.
- (7) For the actual test configuration, please see the test setup photo.

### 5.4 EUT Operating Condition

The Equipment Under Test was set to Continual Transmitting in maximum power.

## 5.5 Test Data

Remark: During testing above 1GHz the measuring instrument use RBW=1 MHz and VBW=3 MHz with Peak Detector for Peak Values, and use RBW=1 MHz and VBW=10 Hz with Peak Detector for Average Values.

Test data please refer the following pages.

**9KHz~30MHz**

From 9KHz to 30MHz: Conclusion: PASS

Note: The amplitude of spurious emissions which are attenuated by more than 20dB below the permissible value has no need to be reported.

**30MHz~1GHz**

<b>EUT:</b>	Smart Clock Camera	<b>Model:</b>	GF-H100base
<b>Temperature:</b>	25 °C	<b>Relative Humidity:</b>	55%
<b>Test Voltage:</b>	DC 3.6V		
<b>Ant. Pol.</b>	Horizontal		
<b>Test Mode:</b>	TX B Mode 2412MHz		
<b>Remark:</b>	Only worse case is reported		

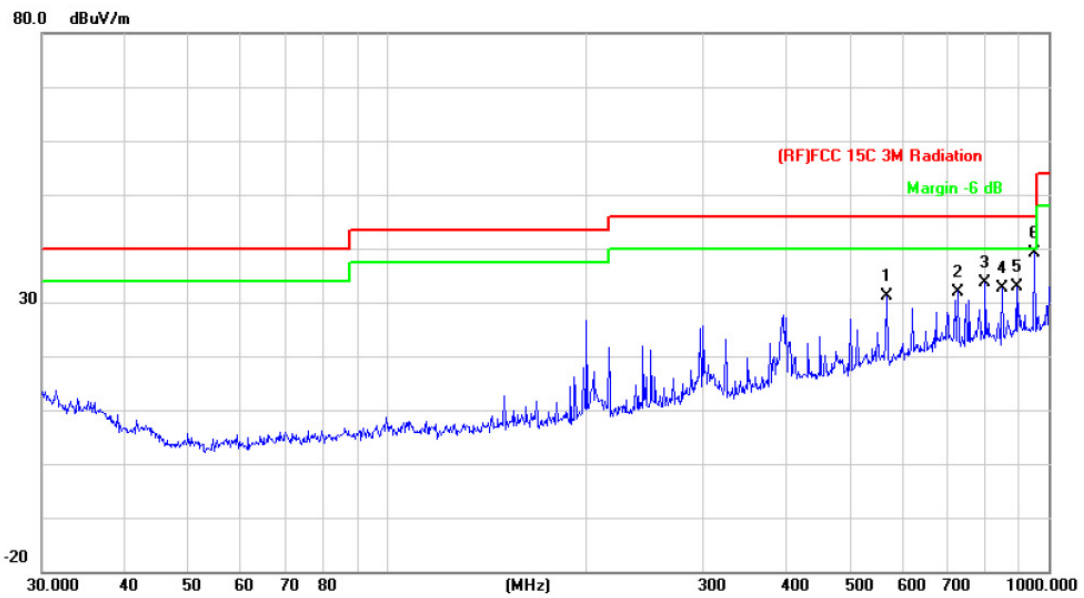

No.	Mk.	Freq.	Reading Level	Correct Factor	Measurement	Limit	Over	Detector
		MHz	dBuV	dB/m	dBuV/m	dBuV/m	dB	
1		568.6127	40.58	-9.47	31.11	46.00	-14.89	peak
2		729.3583	38.08	-6.08	32.00	46.00	-14.00	peak
3		801.7863	38.79	-5.27	33.52	46.00	-12.48	peak
4		851.0353	37.85	-5.31	32.54	46.00	-13.46	peak
5		893.8567	36.79	-3.85	32.94	46.00	-13.06	peak
6	*	952.0937	42.38	-3.25	39.13	46.00	-6.87	peak

\*:Maximum data    x:Over limit    !:over margin

**Emission Level= Read Level+ Correct Factor**

<b>EUT:</b>	Smart Clock Camera	<b>Model:</b>	GF-H100base
<b>Temperature:</b>	25 °C	<b>Relative Humidity:</b>	55%
<b>Test Voltage:</b>	DC 3.6V		
<b>Ant. Pol.</b>	Vertical		
<b>Test Mode:</b>	TX B Mode 2412MHz		
<b>Remark:</b>	Only worse case is reported		

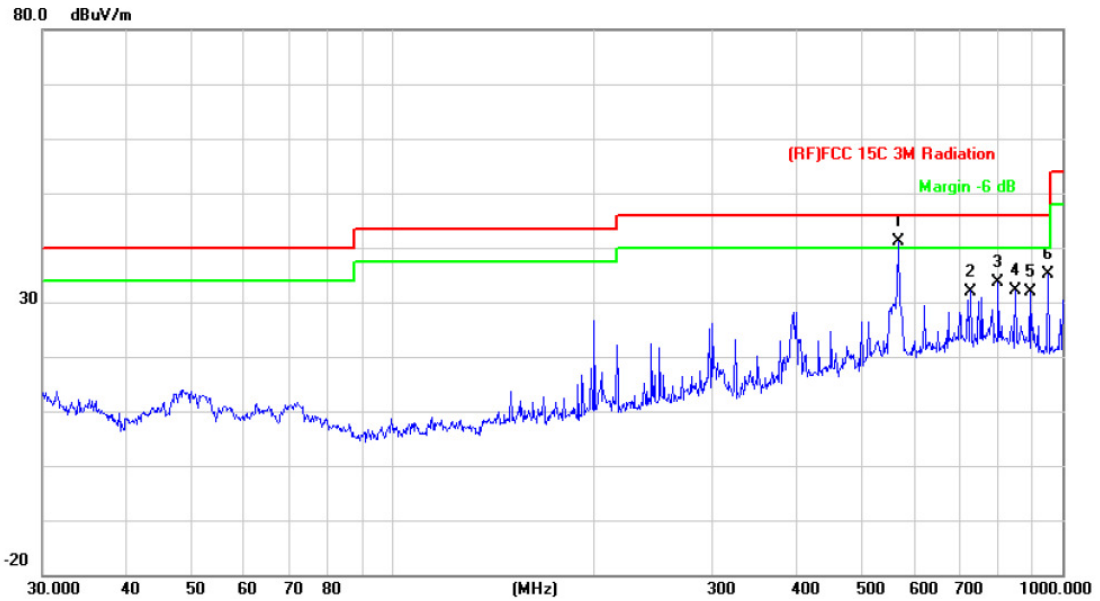

No.	Mk.	Freq.	Reading Level	Correct Factor	Measurement	Limit	Over	Detector
		MHz	dBuV	dB/m	dBuV/m	dBuV/m	dB	
1	*	568.6127	50.58	-9.47	41.11	46.00	-4.89	peak
2		729.3582	38.08	-6.08	32.00	46.00	-14.00	peak
3		801.7862	38.79	-5.27	33.52	46.00	-12.48	peak
4		851.0353	37.35	-5.31	32.04	46.00	-13.96	peak
5		893.8567	35.79	-3.85	31.94	46.00	-14.06	peak
6		952.0937	38.38	-3.25	35.13	46.00	-10.87	peak

\*:Maximum data    x:Over limit    !:over margin

**Emission Level= Read Level+ Correct Factor**

**Above 1GHz**

<b>EUT:</b>	Smart Clock Camera	<b>Model:</b>	GF-H100base
<b>Temperature:</b>	25 °C	<b>Relative Humidity:</b>	55%
<b>Test Voltage:</b>	DC 3.6V		
<b>Ant. Pol.</b>	Horizontal		
<b>Test Mode:</b>	TX B Mode 2412MHz		
<b>Remark:</b>	No report for the emission which more than 10 dB below the prescribed limit.		

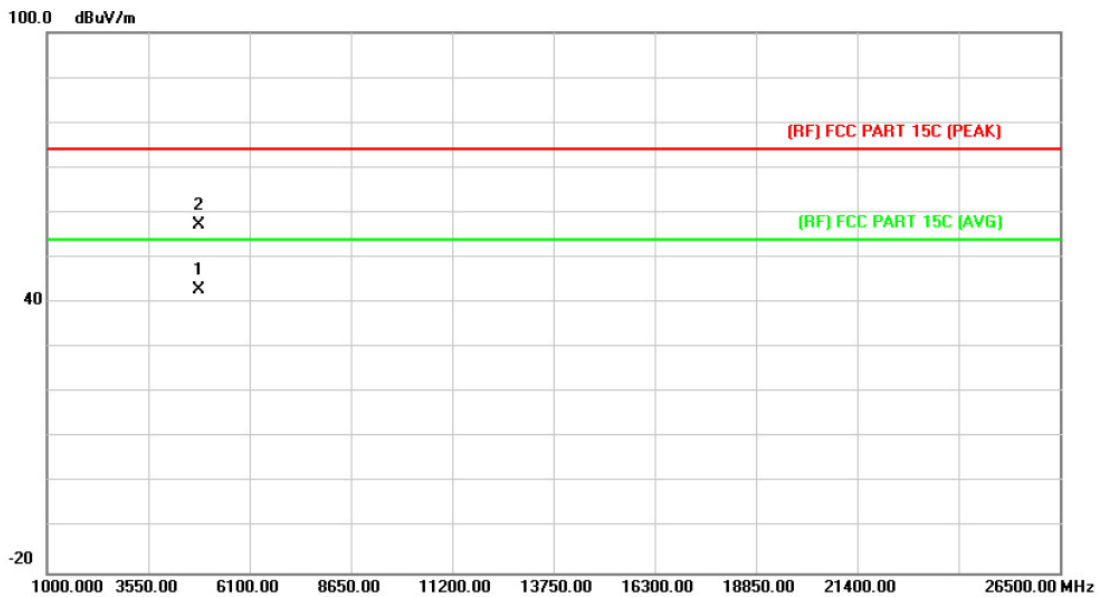

No.	Mk.	Freq.	Reading Level	Correct Factor	Measurement	Limit	Over	Detector
		MHz	dBuV	dB/m	dBuV/m	dBuV/m	dB	
1	*	4823.040	29.23	13.56	42.79	54.00	-11.21	AVG
2		4823.538	43.75	13.56	57.31	74.00	-16.69	peak

**Emission Level= Read Level+ Correct Factor**

<b>EUT:</b>	Smart Clock Camera	<b>Model:</b>	GF-H100base
<b>Temperature:</b>	25 °C	<b>Relative Humidity:</b>	55%
<b>Test Voltage:</b>	DC 3.6V		
<b>Ant. Pol.</b>	Vertical		
<b>Test Mode:</b>	TX B Mode 2412MHz		
<b>Remark:</b>	No report for the emission which more than 10 dB below the prescribed limit.		

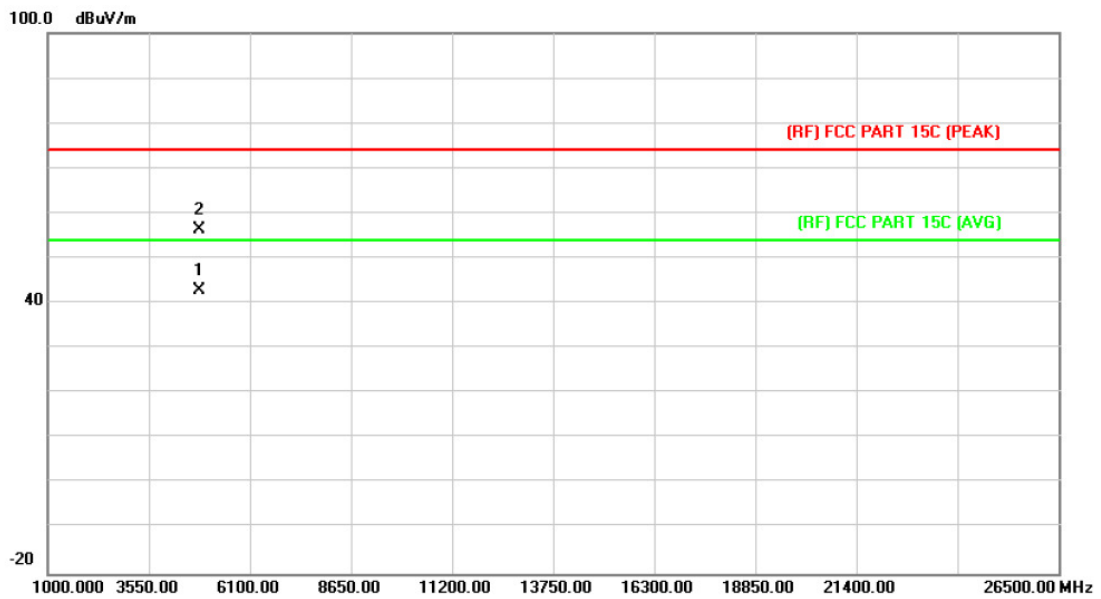

No.	Mk.	Freq. MHz	Reading Level dBuV	Correct Factor dB/m	Measure- ment dBuV/m	Limit dBuV/m	Over dB	Detector
1	*	4823.836	29.17	13.56	42.73	54.00	-11.27	AVG
2		4824.082	42.89	13.56	56.45	74.00	-17.55	peak

Emission Level= Read Level+ Correct Factor

<b>EUT:</b>	Smart Clock Camera	<b>Model:</b>	GF-H100base
<b>Temperature:</b>	25 °C	<b>Relative Humidity:</b>	55%
<b>Test Voltage:</b>	DC 3.6V		
<b>Ant. Pol.</b>	Horizontal		
<b>Test Mode:</b>	TX B Mode 2437MHz		
<b>Remark:</b>	No report for the emission which more than 10 dB below the prescribed limit.		

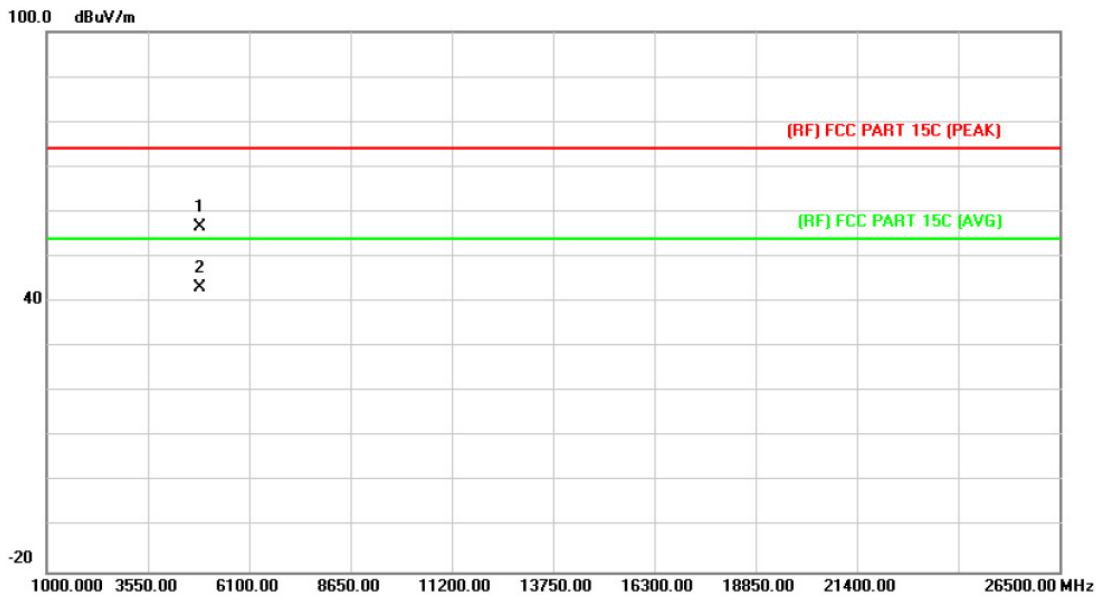

No.	Mk.	Freq. MHz	Reading Level dBuV	Correct Factor dB/m	Measure- ment dBuV/m	Limit dBuV/m	Over dB	Detector
1		4873.374	42.89	13.86	56.75	74.00	-17.25	peak
2	*	4873.928	29.32	13.86	43.18	54.00	-10.82	AVG

Emission Level= Read Level+ Correct Factor

<b>EUT:</b>	Smart Clock Camera	<b>Model:</b>	GF-H100base
<b>Temperature:</b>	25 °C	<b>Relative Humidity:</b>	55%
<b>Test Voltage:</b>	DC 3.6V		
<b>Ant. Pol.</b>	Vertical		
<b>Test Mode:</b>	TX B Mode 2437MHz		
<b>Remark:</b>	No report for the emission which more than 10 dB below the prescribed limit.		

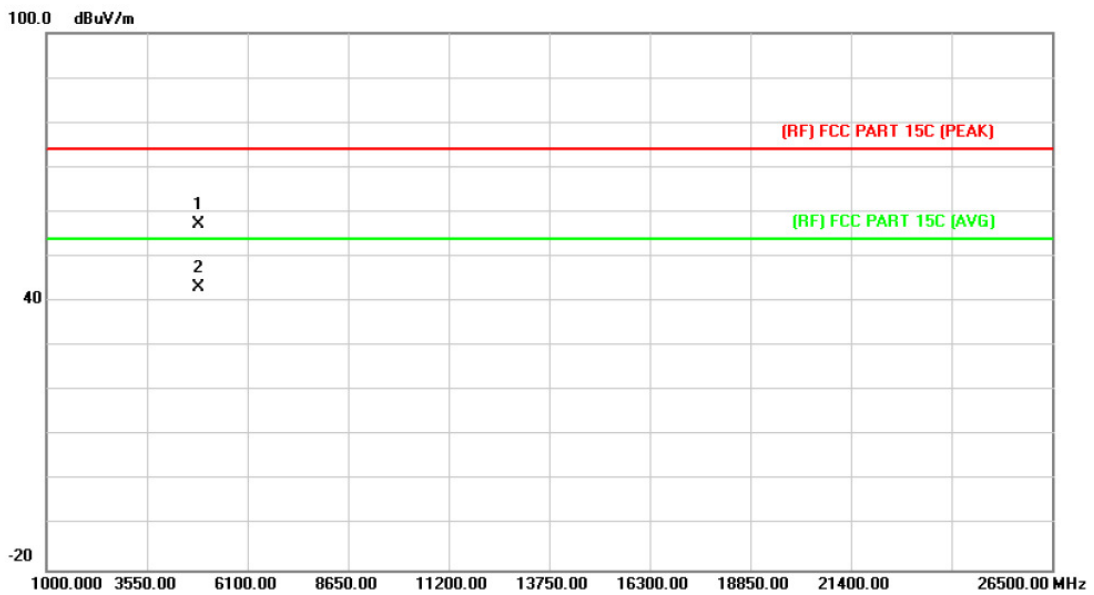

No.	Mk.	Freq.	Reading Level	Correct Factor	Measurement	Limit	Over	Detector
		MHz	dBuV	dB/m	dBuV/m	dBuV/m	dB	
1		4874.080	43.39	13.86	57.25	74.00	-16.75	peak
2	*	4874.434	29.37	13.86	43.23	54.00	-10.77	AVG

Emission Level= Read Level+ Correct Factor

<b>EUT:</b>	Smart Clock Camera	<b>Model:</b>	GF-H100base
<b>Temperature:</b>	25 °C	<b>Relative Humidity:</b>	55%
<b>Test Voltage:</b>	DC 3.6V		
<b>Ant. Pol.</b>	Horizontal		
<b>Test Mode:</b>	TX B Mode 2462MHz		
<b>Remark:</b>	No report for the emission which more than 10 dB below the prescribed limit.		

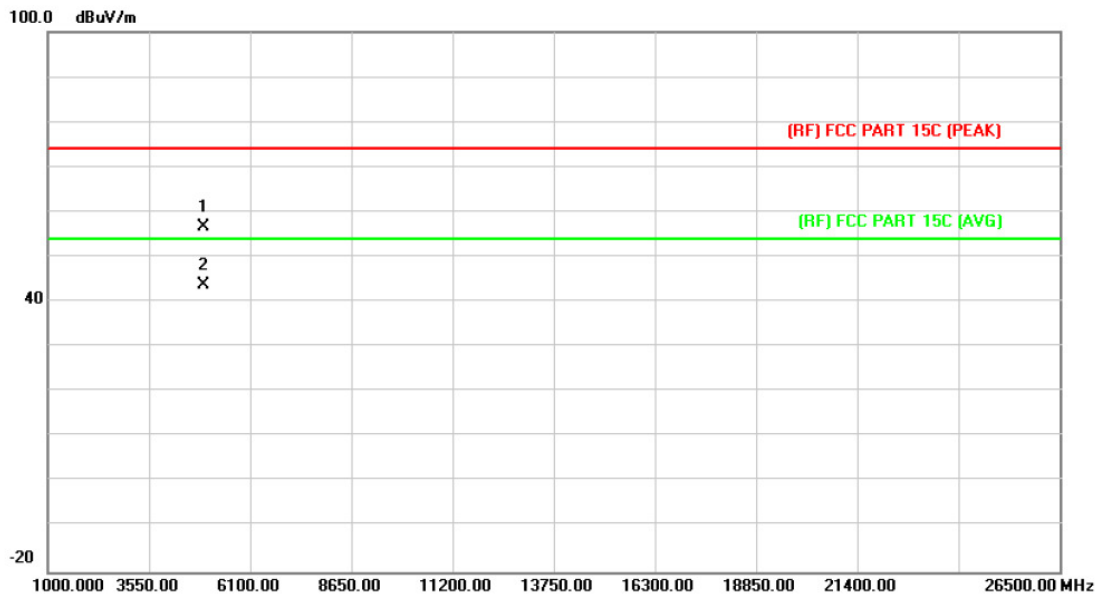

No.	Mk.	Freq. MHz	Reading Level dBuV	Correct Factor dB/m	Measure- ment dBuV/m	Limit dBuV/m	Over dB	Detector
1		4923.556	42.40	14.15	56.55	74.00	-17.45	peak
2	*	4924.778	29.67	14.15	43.82	54.00	-10.18	AVG

**Emission Level= Read Level+ Correct Factor**

<b>EUT:</b>	Smart Clock Camera	<b>Model:</b>	GF-H100base
<b>Temperature:</b>	25 °C	<b>Relative Humidity:</b>	55%
<b>Test Voltage:</b>	DC 3.6V		
<b>Ant. Pol.</b>	Vertical		
<b>Test Mode:</b>	TX B Mode 2462MHz		
<b>Remark:</b>	No report for the emission which more than 10 dB below the prescribed limit.		

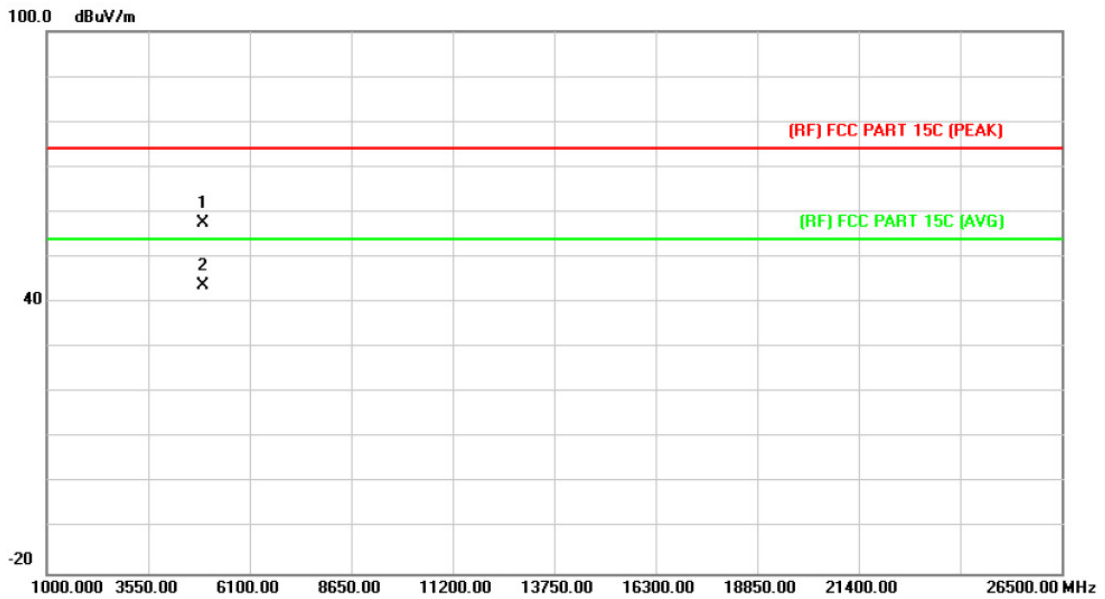

No.	Mk.	Freq. MHz	Reading Level dBuV	Correct Factor dB/m	Measure- ment dBuV/m	Limit dBuV/m	Over dB	Detector
1		4923.168	43.46	14.15	57.61	74.00	-16.39	peak
2	*	4924.718	29.66	14.15	43.81	54.00	-10.19	AVG

Emission Level= Read Level+ Correct Factor

<b>EUT:</b>	Smart Clock Camera	<b>Model:</b>	GF-H100base
<b>Temperature:</b>	25 °C	<b>Relative Humidity:</b>	55%
<b>Test Voltage:</b>	DC 3.6V		
<b>Ant. Pol.</b>	Horizontal		
<b>Test Mode:</b>	TX G Mode 2412MHz		
<b>Remark:</b>	No report for the emission which more than 10 dB below the prescribed limit.		

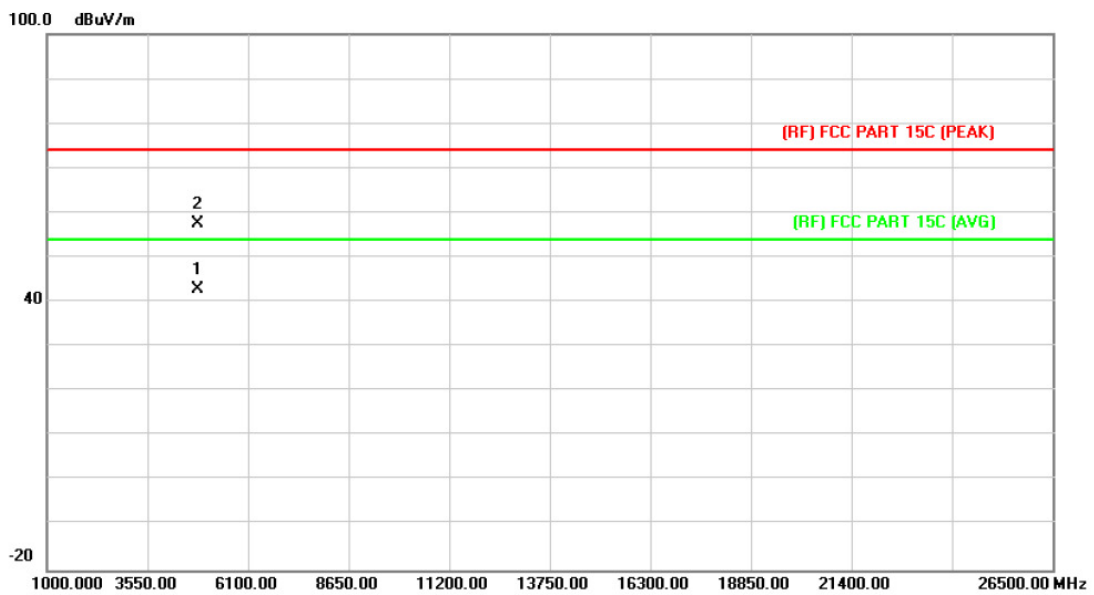

No.	Mk.	Freq.	Reading Level	Correct Factor	Measurement	Limit	Over	Detector
		MHz	dBuV	dB/m	dBuV/m	dBuV/m	dB	
1	*	4823.242	29.21	13.56	42.77	54.00	-11.23	AVG
2		4824.956	43.96	13.56	57.52	74.00	-16.48	peak

Emission Level= Read Level+ Correct Factor

<b>EUT:</b>	Smart Clock Camera	<b>Model:</b>	GF-H100base
<b>Temperature:</b>	25 °C	<b>Relative Humidity:</b>	55%
<b>Test Voltage:</b>	DC 3.6V		
<b>Ant. Pol.</b>	Vertical		
<b>Test Mode:</b>	TX G Mode 2412MHz		
<b>Remark:</b>	No report for the emission which more than 10 dB below the prescribed limit.		

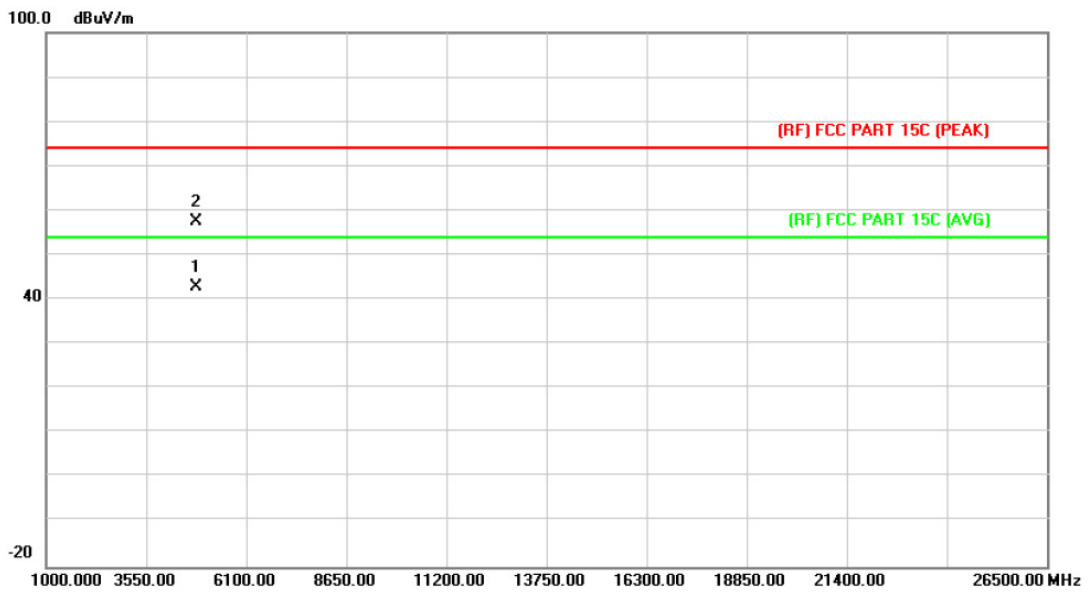

No.	Mk.	Freq.	Reading Level	Correct Factor	Measurement	Limit	Over	Detector
		MHz	dBuV	dB/m	dBuV/m	dBuV/m	dB	
1	*	4824.156	29.18	13.56	42.74	54.00	-11.26	AVG
2		4824.188	43.89	13.56	57.45	74.00	-16.55	peak

Emission Level= Read Level+ Correct Factor

<b>EUT:</b>	Smart Clock Camera	<b>Model:</b>	GF-H100base
<b>Temperature:</b>	25 °C	<b>Relative Humidity:</b>	55%
<b>Test Voltage:</b>	DC 3.6V		
<b>Ant. Pol.</b>	Horizontal		
<b>Test Mode:</b>	TX G Mode 2437MHz		
<b>Remark:</b>	No report for the emission which more than 10 dB below the prescribed limit.		

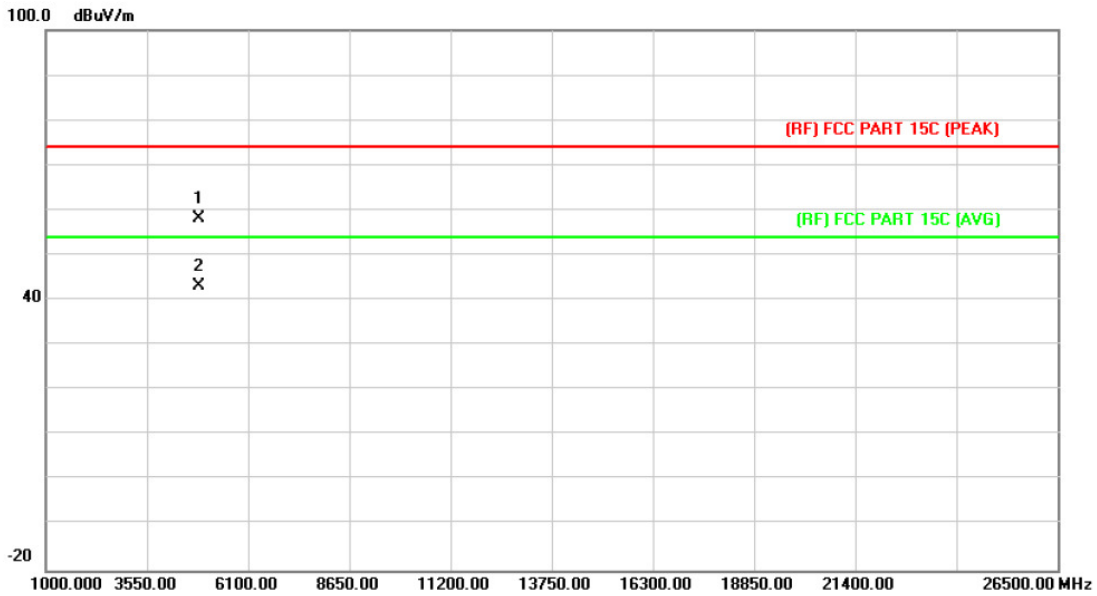

No.	Mk.	Freq. MHz	Reading Level dBuV	Correct Factor dB/m	Measure- ment dBuV/m	Limit dBuV/m	Over dB	Detector
1		4874.680	44.39	13.86	58.25	74.00	-15.75	peak
2	*	4874.838	29.37	13.86	43.23	54.00	-10.77	AVG

Emission Level= Read Level+ Correct Factor

<b>EUT:</b>	Smart Clock Camera	<b>Model:</b>	GF-H100base
<b>Temperature:</b>	25 °C	<b>Relative Humidity:</b>	55%
<b>Test Voltage:</b>	DC 3.6V		
<b>Ant. Pol.</b>	Vertical		
<b>Test Mode:</b>	TX G Mode 2437MHz		
<b>Remark:</b>	No report for the emission which more than 10 dB below the prescribed limit.		

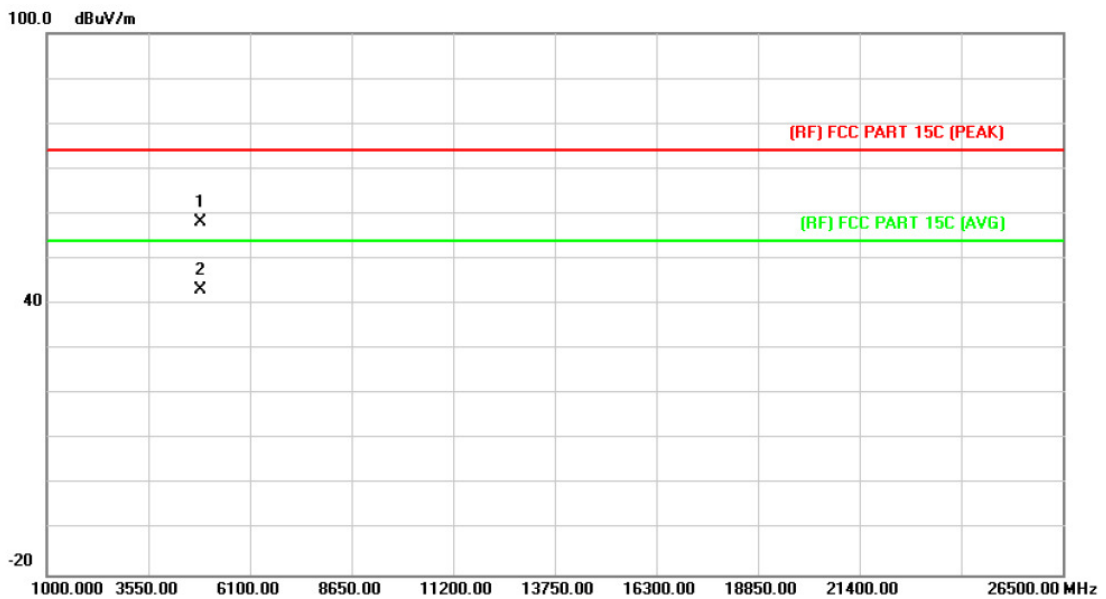

No.	Mk.	Freq.	Reading Level	Correct Factor	Measurement	Limit	Over	Detector
		MHz	dBuV	dB/m	dBuV/m	dBuV/m	dB	
1		4873.444	44.25	13.86	58.11	74.00	-15.89	peak
2	*	4874.554	29.35	13.86	43.21	54.00	-10.79	AVG

Emission Level= Read Level+ Correct Factor

<b>EUT:</b>	Smart Clock Camera	<b>Model:</b>	GF-H100base
<b>Temperature:</b>	25 °C	<b>Relative Humidity:</b>	55%
<b>Test Voltage:</b>	DC 3.6V		
<b>Ant. Pol.</b>	Horizontal		
<b>Test Mode:</b>	TX G Mode 2462MHz		
<b>Remark:</b>	No report for the emission which more than 10 dB below the prescribed limit.		

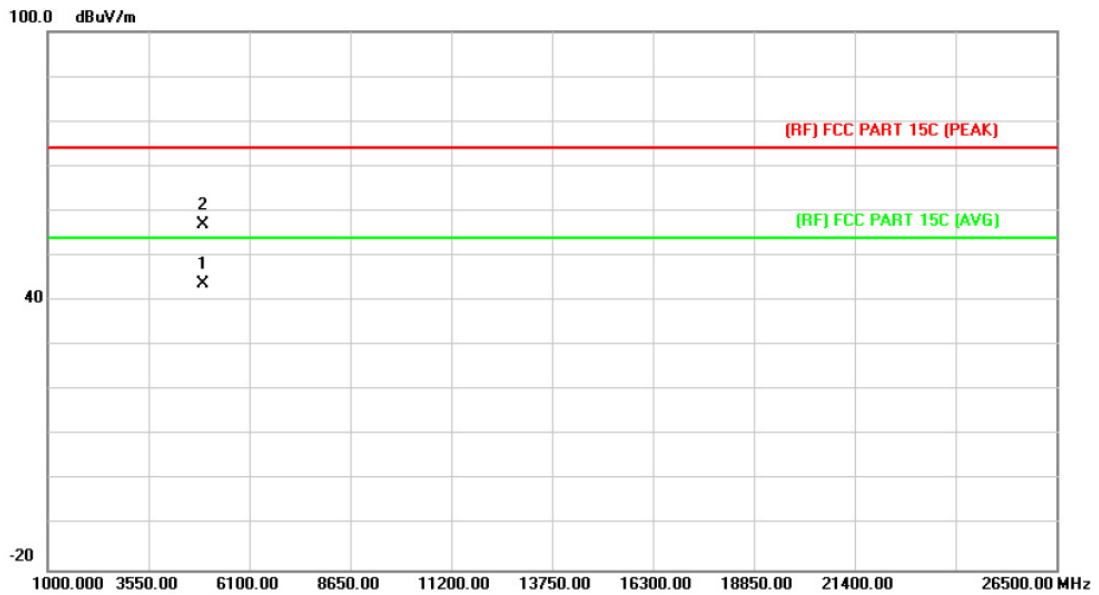

No.	Mk.	Freq. MHz	Reading Level dBuV	Correct Factor dB/m	Measure- ment dBuV/m	Limit dBuV/m	Over dB	Detector
1	*	4924.516	29.68	14.15	43.83	54.00	-10.17	AVG
2		4924.538	42.92	14.15	57.07	74.00	-16.93	peak

Emission Level= Read Level+ Correct Factor

<b>EUT:</b>	Smart Clock Camera	<b>Model:</b>	GF-H100base
<b>Temperature:</b>	25 °C	<b>Relative Humidity:</b>	55%
<b>Test Voltage:</b>	DC 3.6V		
<b>Ant. Pol.</b>	Vertical		
<b>Test Mode:</b>	TX G Mode 2462MHz		
<b>Remark:</b>	No report for the emission which more than 10 dB below the prescribed limit.		

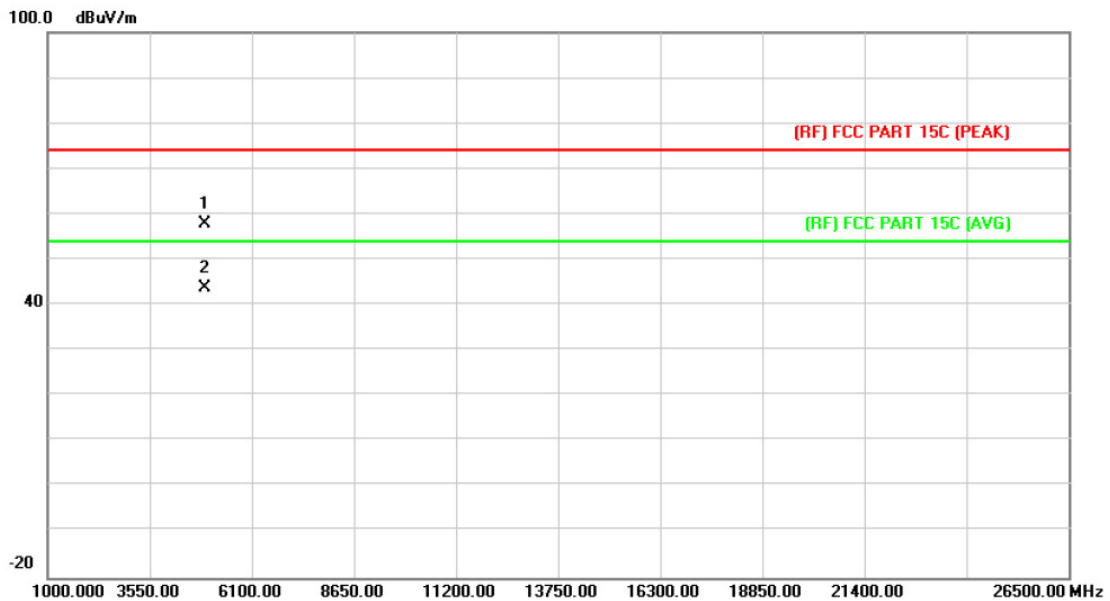

No.	Mk.	Freq. MHz	Reading Level dBuV	Correct Factor dB/m	Measure- ment dBuV/m	Limit dBuV/m	Over dB	Detector
1		4924.554	43.85	14.15	58.00	74.00	-16.00	peak
2	*	4924.720	29.65	14.15	43.80	54.00	-10.20	AVG

Emission Level= Read Level+ Correct Factor

<b>EUT:</b>	Smart Clock Camera	<b>Model:</b>	GF-H100base
<b>Temperature:</b>	25 °C	<b>Relative Humidity:</b>	55%
<b>Test Voltage:</b>	DC 3.6V		
<b>Ant. Pol.</b>	Horizontal		
<b>Test Mode:</b>	TX N(HT20) Mode 2412MHz		
<b>Remark:</b>	No report for the emission which more than 10 dB below the prescribed limit.		

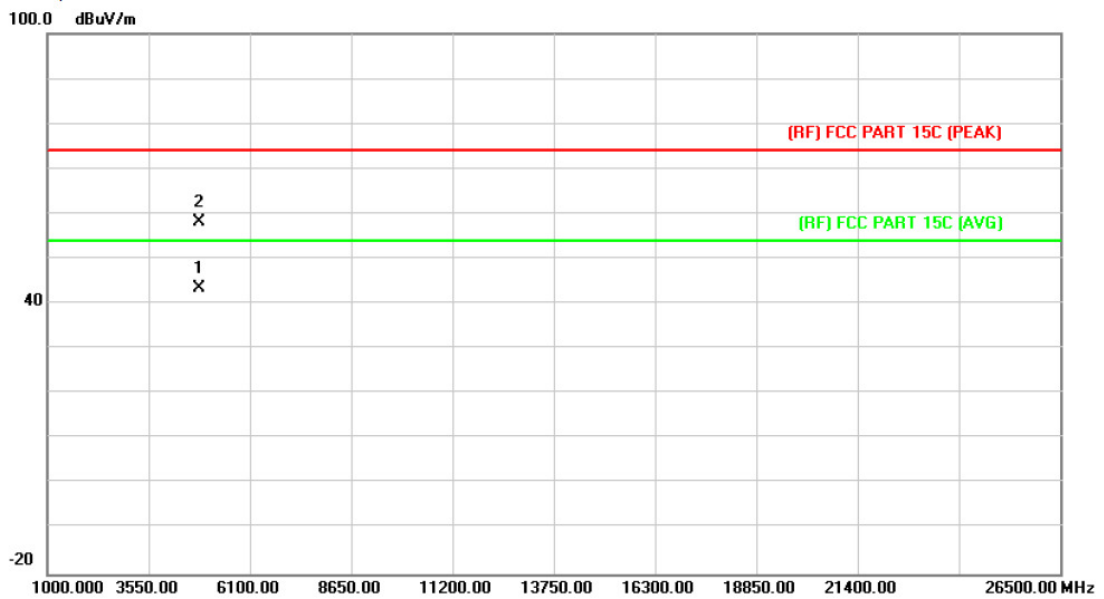

No.	Mk.	Freq.	Reading Level	Correct Factor	Measurement	Limit	Over	Detector
		MHz	dBuV	dB/m	dBuV/m	dBuV/m	dB	
1	*	4823.738	29.83	13.56	43.39	54.00	-10.61	AVG
2		4824.164	44.72	13.56	58.28	74.00	-15.72	peak

Emission Level= Read Level+ Correct Factor

<b>EUT:</b>	Smart Clock Camera	<b>Model:</b>	GF-H100base
<b>Temperature:</b>	25 °C	<b>Relative Humidity:</b>	55%
<b>Test Voltage:</b>	DC 3.6V		
<b>Ant. Pol.</b>	Vertical		
<b>Test Mode:</b>	TX N(HT20) Mode 2412MHz		
<b>Remark:</b>	No report for the emission which more than 10 dB below the prescribed limit.		

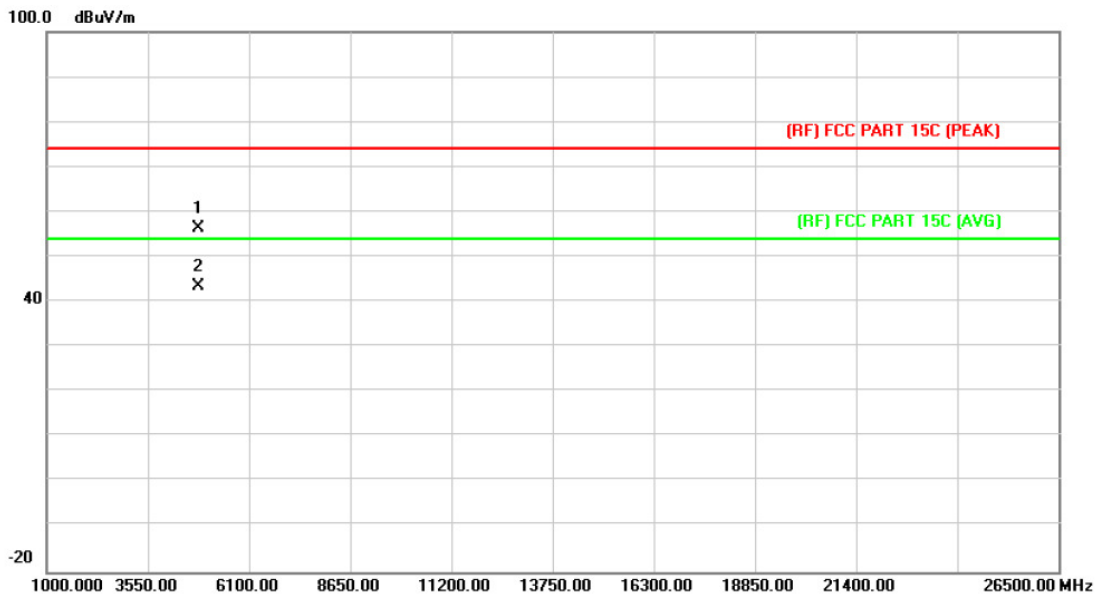

No.	Mk.	Freq.	Reading Level	Correct Factor	Measurement	Limit	Over	Detector
		MHz	dBuV	dB/m	dBuV/m	dBuV/m	dB	
1		4823.312	42.78	13.56	56.34	74.00	-17.66	peak
2	*	4823.888	29.96	13.56	43.52	54.00	-10.48	AVG

Emission Level= Read Level+ Correct Factor

<b>EUT:</b>	Smart Clock Camera	<b>Model:</b>	GF-H100base
<b>Temperature:</b>	25 °C	<b>Relative Humidity:</b>	55%
<b>Test Voltage:</b>	DC 3.6V		
<b>Ant. Pol.</b>	Horizontal		
<b>Test Mode:</b>	TX N(HT20) Mode 2437MHz		
<b>Remark:</b>	No report for the emission which more than 10 dB below the prescribed limit.		

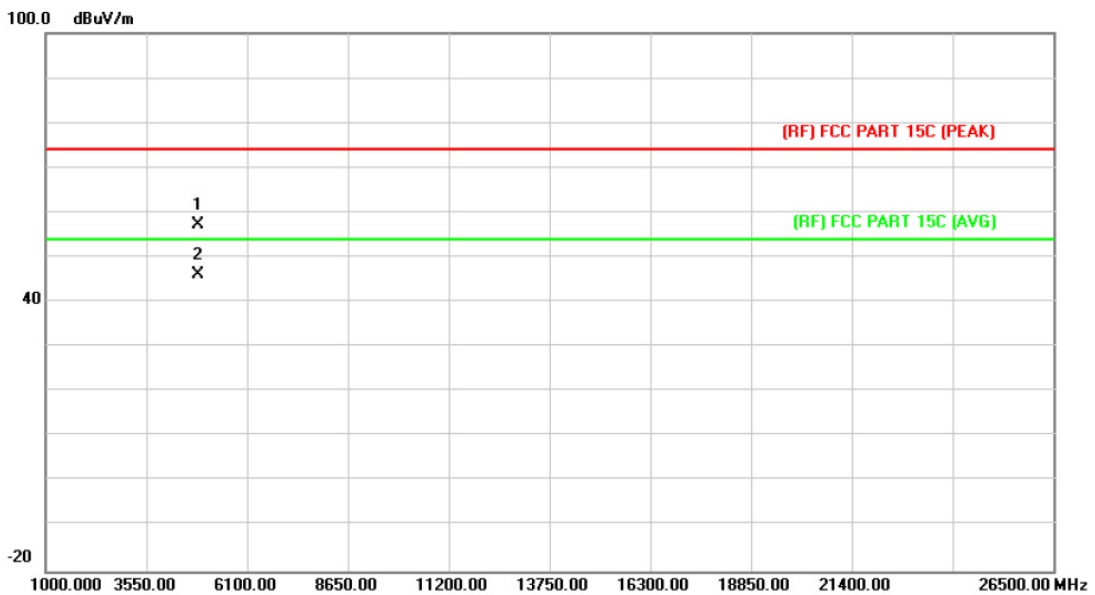

No.	Mk.	Freq.	Reading Level	Correct Factor	Measurement	Limit	Over	Detector
		MHz	dBuV	dB/m	dBuV/m	dBuV/m	dB	
1		4874.442	43.53	13.86	57.39	74.00	-16.61	peak
2	*	4874.720	32.21	13.86	46.07	54.00	-7.93	AVG

Emission Level= Read Level+ Correct Factor

<b>EUT:</b>	Smart Clock Camera	<b>Model:</b>	GF-H100base
<b>Temperature:</b>	25 °C	<b>Relative Humidity:</b>	55%
<b>Test Voltage:</b>	DC 3.6V		
<b>Ant. Pol.</b>	Vertical		
<b>Test Mode:</b>	TX N(HT20) Mode 2437MHz		
<b>Remark:</b>	No report for the emission which more than 10 dB below the prescribed limit.		

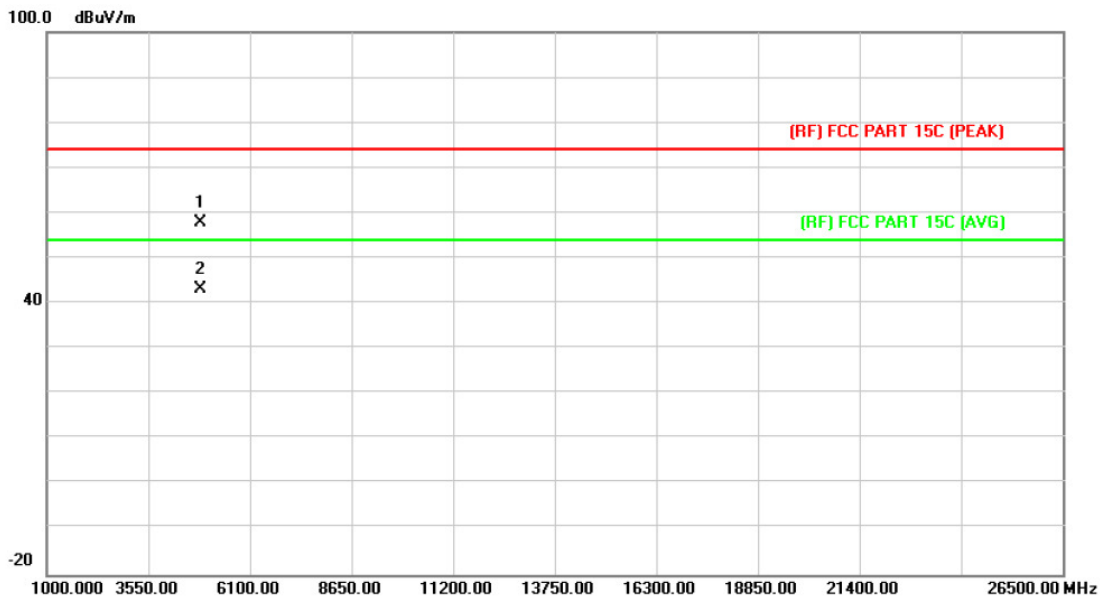

No.	Mk.	Freq. MHz	Reading Level dBuV	Correct Factor dB/m	Measure- ment dBuV/m	Limit dBuV/m	Over dB	Detector
1		4873.222	44.08	13.86	57.94	74.00	-16.06	peak
2	*	4874.494	29.34	13.86	43.20	54.00	-10.80	AVG

Emission Level= Read Level+ Correct Factor

<b>EUT:</b>	Smart Clock Camera	<b>Model:</b>	GF-H100base
<b>Temperature:</b>	25 °C	<b>Relative Humidity:</b>	55%
<b>Test Voltage:</b>	DC 3.6V		
<b>Ant. Pol.</b>	Horizontal		
<b>Test Mode:</b>	TX N(HT20) Mode 2462MHz		
<b>Remark:</b>	No report for the emission which more than 10 dB below the prescribed limit.		

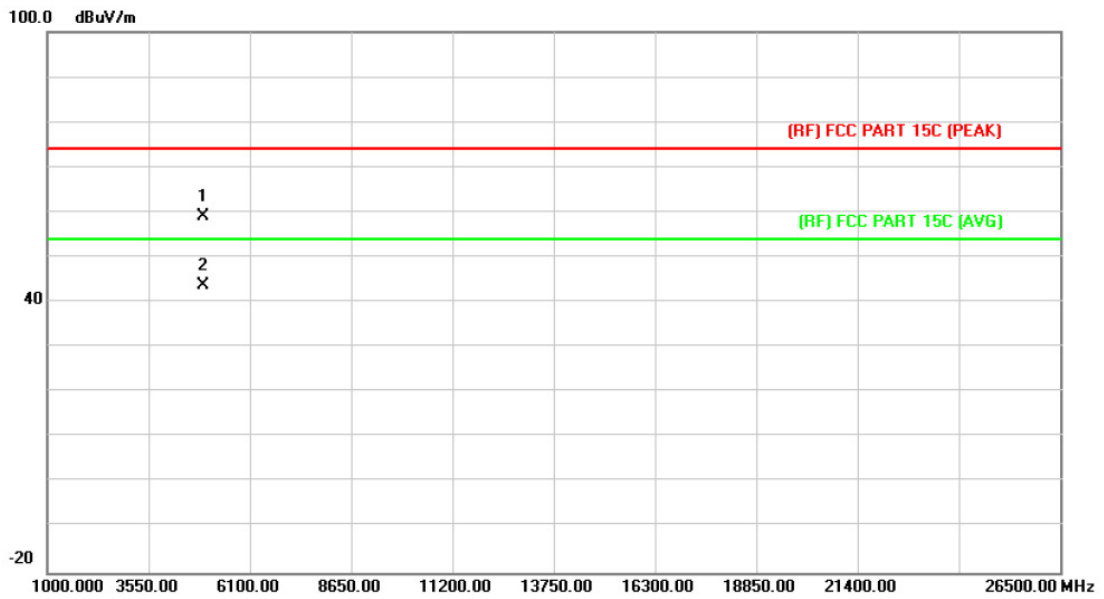

No.	Mk.	Freq. MHz	Reading Level dBuV	Correct Factor dB/m	Measure- ment dBuV/m	Limit dBuV/m	Over dB	Detector
1		4924.142	44.78	14.15	58.93	74.00	-15.07	peak
2	*	4924.374	29.66	14.15	43.81	54.00	-10.19	AVG

Emission Level= Read Level+ Correct Factor

<b>EUT:</b>	Smart Clock Camera	<b>Model:</b>	GF-H100base
<b>Temperature:</b>	25 °C	<b>Relative Humidity:</b>	55%
<b>Test Voltage:</b>	DC 3.6V		
<b>Ant. Pol.</b>	Vertical		
<b>Test Mode:</b>	TX N(HT20) Mode 2462MHz		
<b>Remark:</b>	No report for the emission which more than 10 dB below the prescribed limit.		

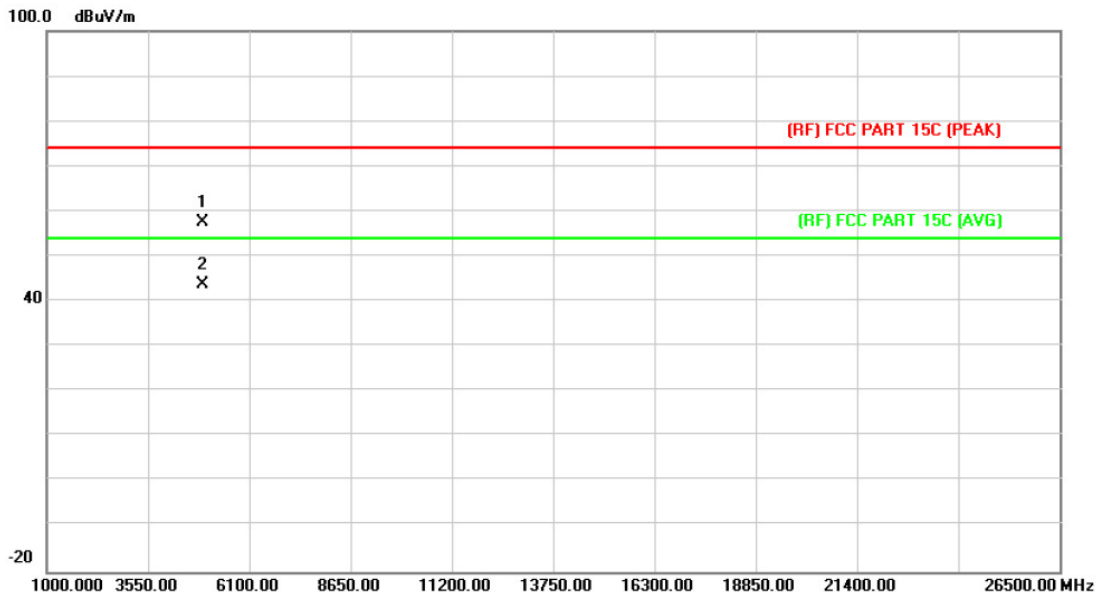

No.	Mk.	Freq. MHz	Reading Level dBuV	Correct Factor dB/m	Measure- ment dBuV/m	Limit dBuV/m	Over dB	Detector
1		4923.278	43.43	14.15	57.58	74.00	-16.42	peak
2	*	4924.708	29.62	14.15	43.77	54.00	-10.23	AVG

Emission Level= Read Level+ Correct Factor

<b>EUT:</b>	Smart Clock Camera	<b>Model:</b>	GF-H100base
<b>Temperature:</b>	25 °C	<b>Relative Humidity:</b>	55%
<b>Test Voltage:</b>	DC 3.6V		
<b>Ant. Pol.</b>	Horizontal		
<b>Test Mode:</b>	TX N(HT40) Mode 2422MHz		
<b>Remark:</b>	No report for the emission which more than 10 dB below the prescribed limit.		

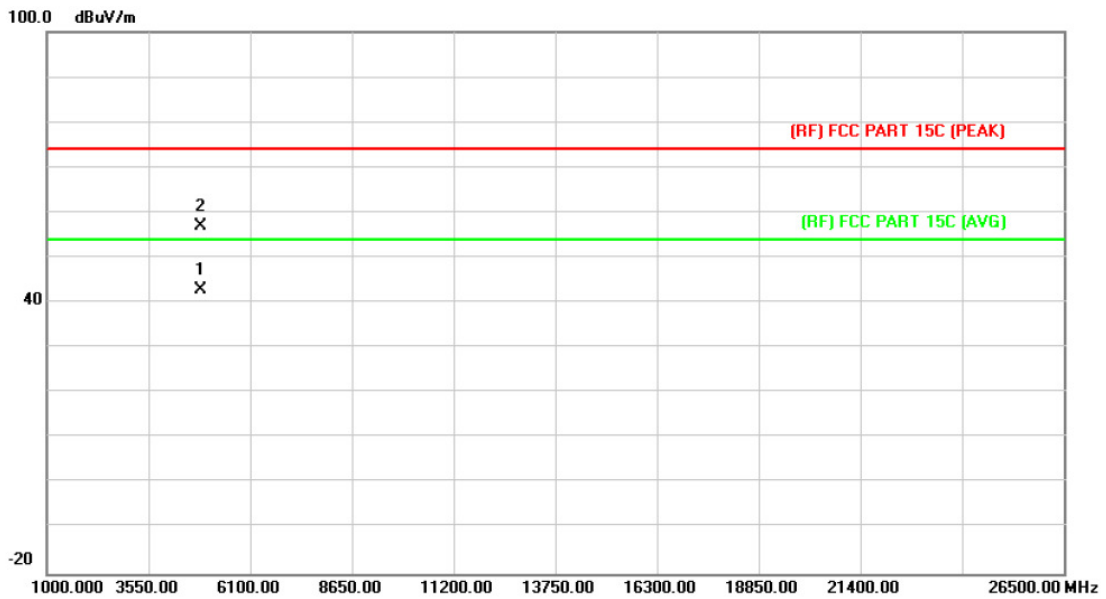

No.	Mk.	Freq.	Reading Level	Correct Factor	Measurement	Limit	Over	Detector
		MHz	dBuV	dB/m	dBuV/m	dBuV/m	dB	
1	*	4843.200	29.31	13.68	42.99	54.00	-11.01	AVG
2		4843.476	43.16	13.68	56.84	74.00	-17.16	peak

Emission Level= Read Level+ Correct Factor

<b>EUT:</b>	Smart Clock Camera	<b>Model:</b>	GF-H100base
<b>Temperature:</b>	25 °C	<b>Relative Humidity:</b>	55%
<b>Test Voltage:</b>	DC 3.6V		
<b>Ant. Pol.</b>	Vertical		
<b>Test Mode:</b>	TX N(HT40) Mode 2422MHz		
<b>Remark:</b>	No report for the emission which more than 10 dB below the prescribed limit.		

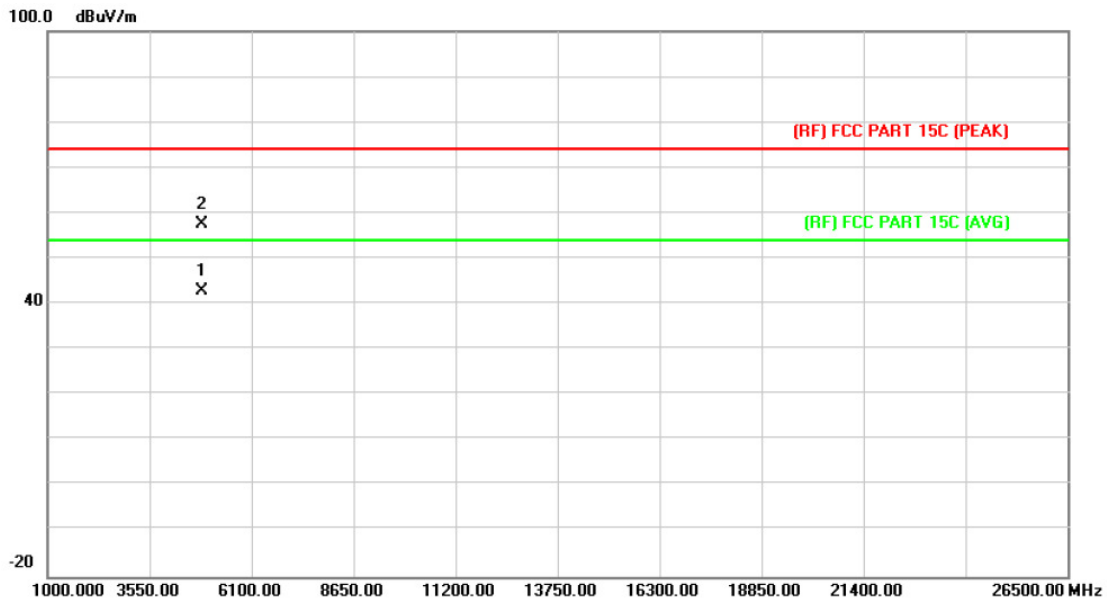

No.	Mk.	Freq.	Reading Level	Correct Factor	Measurement	Limit	Over	Detector
		MHz	dBuV	dB/m	dBuV/m	dBuV/m	dB	
1	*	4843.768	29.31	13.68	42.99	54.00	-11.01	AVG
2		4844.928	43.80	13.68	57.48	74.00	-16.52	peak

Emission Level= Read Level+ Correct Factor

<b>EUT:</b>	Smart Clock Camera	<b>Model:</b>	GF-H100base
<b>Temperature:</b>	25 °C	<b>Relative Humidity:</b>	55%
<b>Test Voltage:</b>	DC 3.6V		
<b>Ant. Pol.</b>	Horizontal		
<b>Test Mode:</b>	TX N(HT40) Mode 2437MHz		
<b>Remark:</b>	No report for the emission which more than 10 dB below the prescribed limit.		

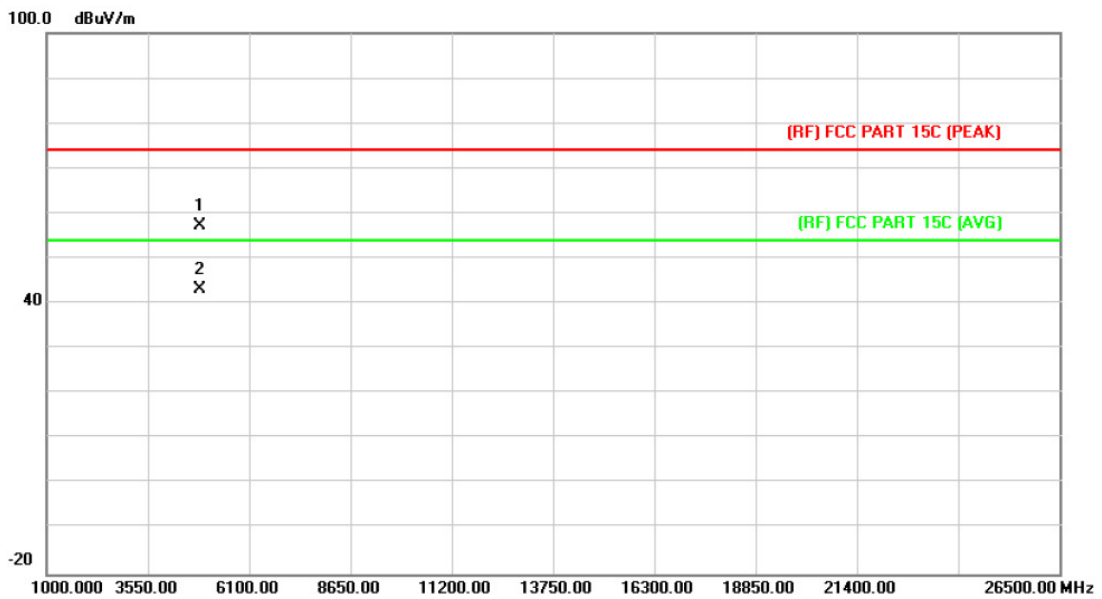

No.	Mk.	Freq. MHz	Reading Level dBuV	Correct Factor dB/m	Measure- ment dBuV/m	Limit dBuV/m	Over dB	Detector
1		4873.012	43.41	13.86	57.27	74.00	-16.73	peak
2	*	4874.354	29.36	13.86	43.22	54.00	-10.78	AVG

Emission Level= Read Level+ Correct Factor

<b>EUT:</b>	Smart Clock Camera	<b>Model:</b>	GF-H100base
<b>Temperature:</b>	25 °C	<b>Relative Humidity:</b>	55%
<b>Test Voltage:</b>	DC 3.6V		
<b>Ant. Pol.</b>	Vertical		
<b>Test Mode:</b>	TX N(HT40) Mode 2437MHz		
<b>Remark:</b>	No report for the emission which more than 10 dB below the prescribed limit.		

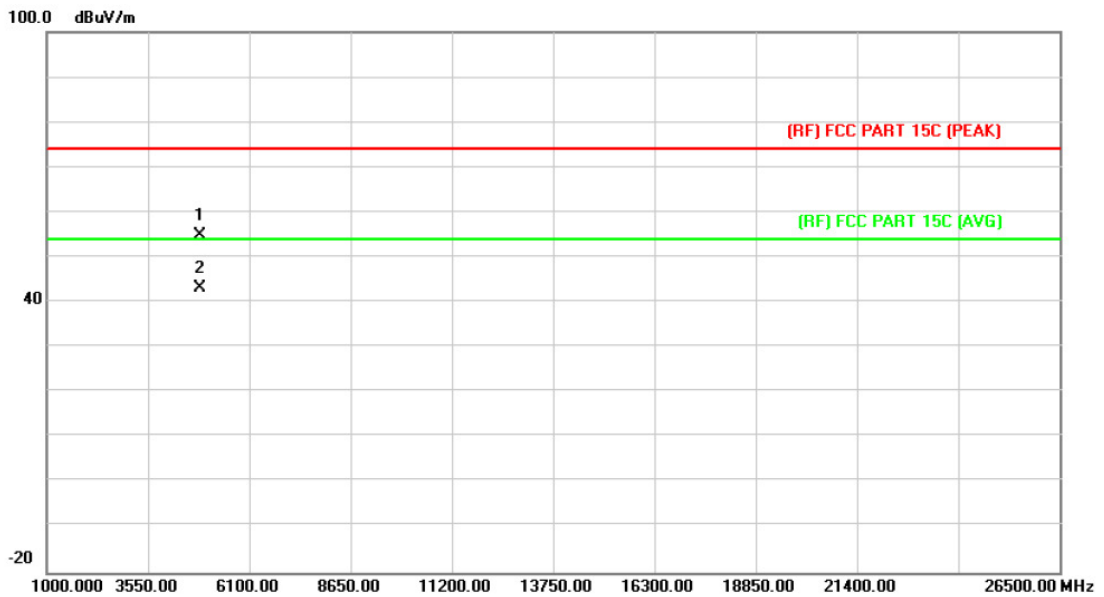

No.	Mk.	Freq.	Reading Level	Correct Factor	Measurement	Limit	Over	Detector
		MHz	dBuV	dB/m	dBuV/m	dBuV/m	dB	
1		4873.682	41.13	13.86	54.99	74.00	-19.01	peak
2	*	4874.516	29.36	13.86	43.22	54.00	-10.78	AVG

Emission Level= Read Level+ Correct Factor

<b>EUT:</b>	Smart Clock Camera	<b>Model:</b>	GF-H100base
<b>Temperature:</b>	25 °C	<b>Relative Humidity:</b>	55%
<b>Test Voltage:</b>	DC 3.6V		
<b>Ant. Pol.</b>	Horizontal		
<b>Test Mode:</b>	TX N(HT40) Mode 2452MHz		
<b>Remark:</b>	No report for the emission which more than 10 dB below the prescribed limit.		

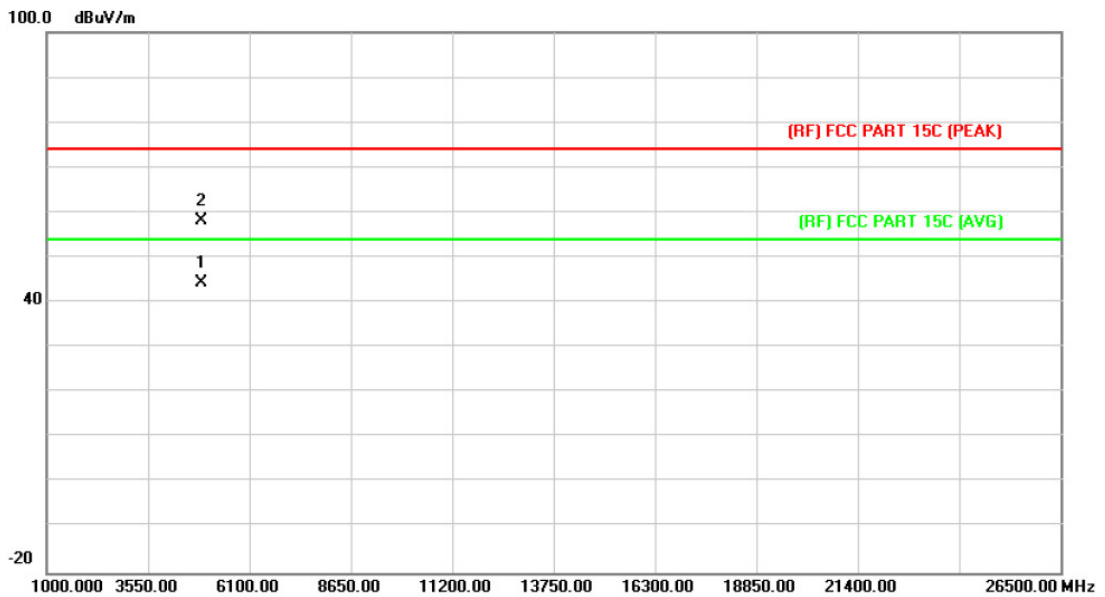

No.	Mk.	Freq.	Reading Level	Correct Factor	Measurement	Limit	Over	Detector
		MHz	dBuV	dB/m	dBuV/m	dBuV/m	dB	
1	*	4903.765	30.23	14.03	44.26	54.00	-9.74	AVG
2		4904.271	44.04	14.03	58.07	74.00	-15.93	peak

Emission Level= Read Level+ Correct Factor

<b>EUT:</b>	Smart Clock Camera	<b>Model:</b>	GF-H100base
<b>Temperature:</b>	25 °C	<b>Relative Humidity:</b>	55%
<b>Test Voltage:</b>	DC 3.6V		
<b>Ant. Pol.</b>	Vertical		
<b>Test Mode:</b>	TX N(HT40) Mode 2452MHz		
<b>Remark:</b>	No report for the emission which more than 10 dB below the prescribed limit.		

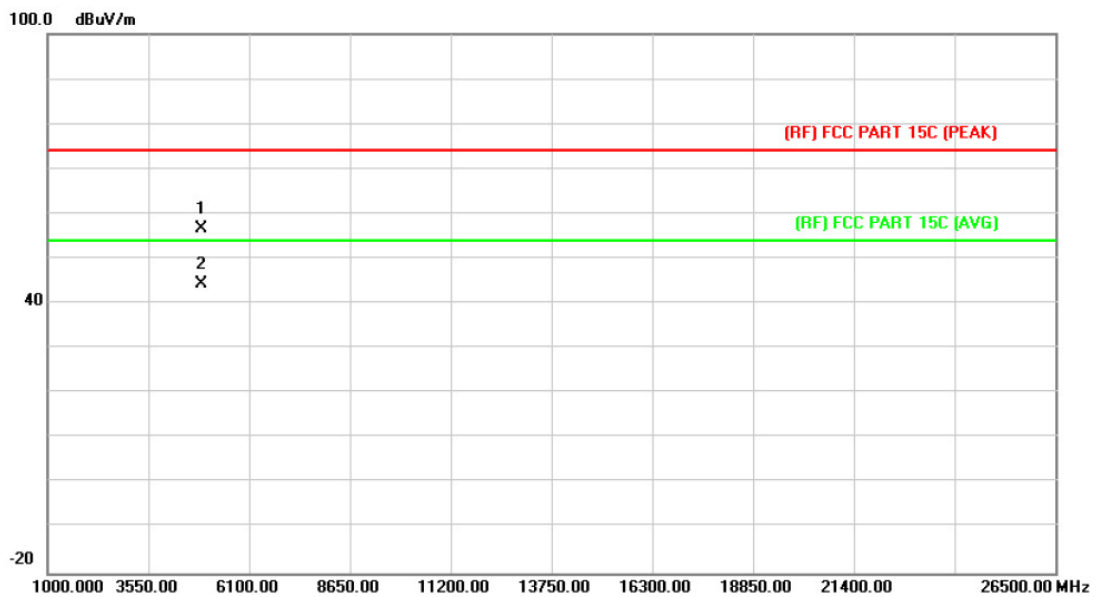

No.	Mk.	Freq. MHz	Reading Level dBuV	Correct Factor dB/m	Measure- ment dBuV/m	Limit dBuV/m	Over dB	Detector
1		4904.725	42.69	14.03	56.72	74.00	-17.28	peak
2	*	4905.672	30.22	14.05	44.27	54.00	-9.73	AVG

Emission Level= Read Level+ Correct Factor

## 6. Restricted Bands Requirement

### 6.1 Test Standard and Limit

#### 6.1.1 Test Standard

FCC Part 15.247(d)

FCC Part 15.209

FCC Part 15.205

#### 6.1.2 Test Limit

Restricted Frequency Band (MHz)	Distance of 3m (dBuV/m)	
	Peak	Average
2310 ~2390	74	54
2483.5 ~2500	74	54

### 6.2 Test Setup

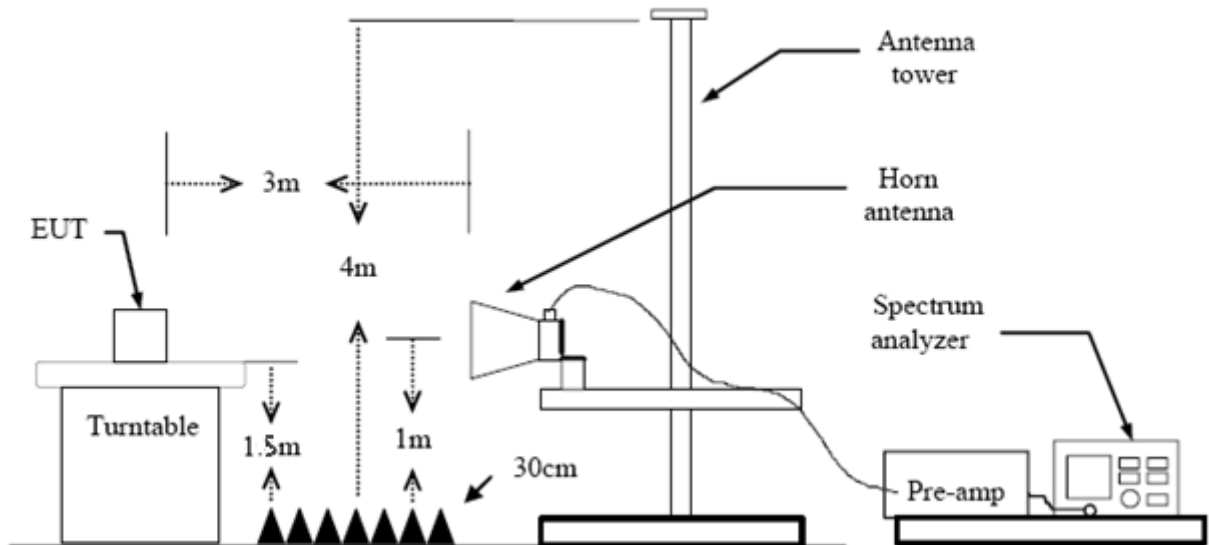

### 6.3 Test Procedure

- (1) The measuring distance of 3m shall be used for measurements at frequency up to 1GHz and above 1 GHz. The EUT was placed on a rotating 0.8m high above ground, the table was rotated 360 degrees to determine the position of the highest radiation.
- (2) Measurements at frequency above 1GHz. The EUT was placed on a rotating 1.5m high above the ground. RF absorbers covered the ground plane with a minimum area of 3.0m by 3.0m between the EUT and measurement receiver antenna. The RF absorber shall not exceed 30cm in high above the conducting floor. The table was rotated 360 degrees to determine the position of the highest radiation.

- (3) The Test antenna shall vary between 1m and 4m, Both Horizontal and Vertical antenna are set to make measurement.
- (4) The initial step in collecting conducted emission data is a spectrum analyzer peak detector mode pre-scanning the measurement frequency range. Significant peaks are then marked and then Quasi Peak detector mode re-measured.
- (5) If the Peak Mode measured value compliance with and lower than Quasi Peak Mode Limit Bellow 1 GHz, the EUT shall be deemed to meet QP Limits and then no additional QP Mode measurement performed. But the Peak Value and average value both need to comply with applicable limit above 1 GHz.
- (6) Testing frequency range below 1GHz the measuring instrument use VBW=120 kHz with Quasi-peak detection.
- (7) Testing frequency range above 1GHz the measuring instrument use RBW=1 MHz and VBW=3 MHz with Peak Detector for Peak Values, and use RBW=1 MHz and VBW=10 Hz with Peak Detector for Average Values.
- (8) For the actual test configuration, please see the test setup photo.

#### 6.4 EUT Operating Condition

The Equipment Under Test was set to Continual Transmitting in maximum power.

#### 6.5 Test Data

Please see the next page.

**(1) Radiation Test**

<b>EUT:</b>	Smart Clock Camera	<b>Model:</b>	GF-H100base
<b>Temperature:</b>	25 °C	<b>Relative Humidity:</b>	55%
<b>Test Voltage:</b>	DC 3.6V		
<b>Ant. Pol.</b>	Horizontal		
<b>Test Mode:</b>	TX B Mode 2412MHz		
<b>Remark:</b>	N/A		

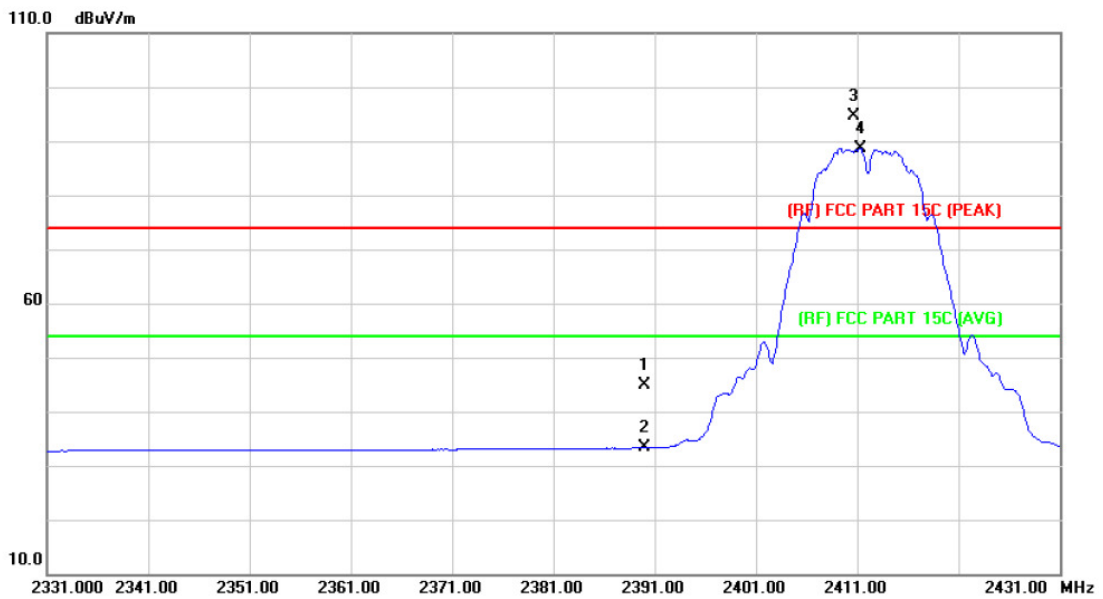

No.	Mk.	Freq. MHz	Reading Level dBuV	Correct Factor dB/m	Measure- ment dBuV/m	Limit dBuV/m	Over dB	Detector
1		2390.000	44.04	0.77	44.81	74.00	-29.19	peak
2		2390.000	32.58	0.77	33.35	54.00	-20.65	AVG
3	X	2410.700	93.86	0.86	94.72	Fundamental Frequency		peak
4	*	2411.300	87.77	0.86	88.63	Fundamental Frequency		AVG

Emission Level= Read Level+ Correct Factor

<b>EUT:</b>	Smart Clock Camera	<b>Model:</b>	GF-H100base
<b>Temperature:</b>	25 °C	<b>Relative Humidity:</b>	55%
<b>Test Voltage:</b>	DC 3.6V		
<b>Ant. Pol.</b>	Vertical		
<b>Test Mode:</b>	TX B Mode 2412MHz		
<b>Remark:</b>	N/A		

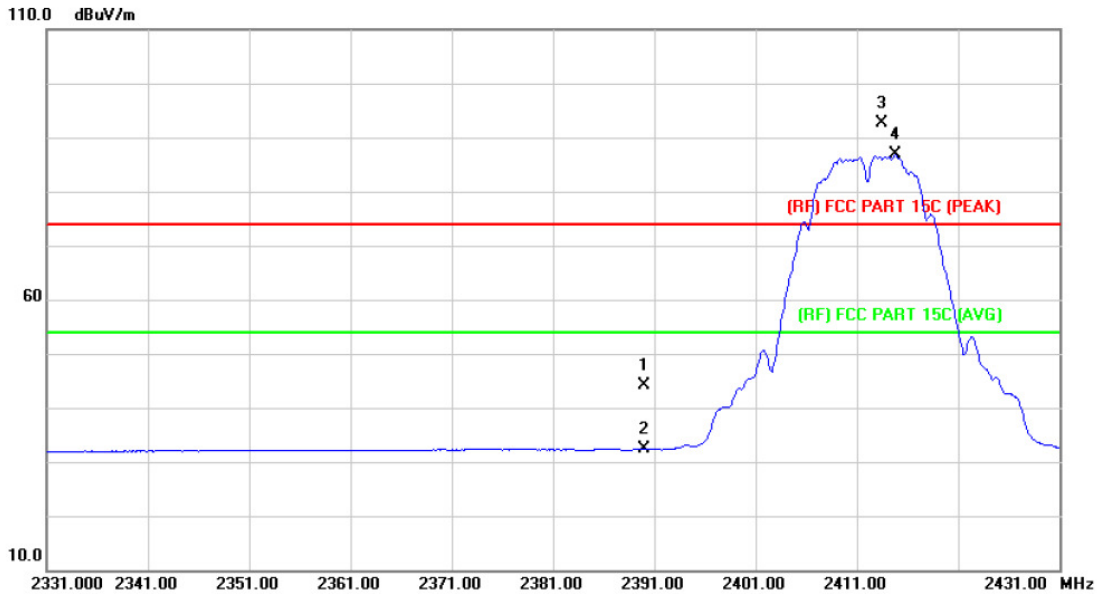

No.	Mk.	Freq. MHz	Reading Level dBuV	Correct Factor dB/m	Measure- ment dBuV/m	Limit dBuV/m	Over dB	Detector
1		2390.000	43.31	0.77	44.08	74.00	-29.92	peak
2		2390.000	31.56	0.77	32.33	54.00	-21.67	AVG
3	X	2413.500	91.76	0.86	92.62	Fundamental Frequency		peak
4	*	2414.800	85.94	0.88	86.82	Fundamental Frequency		AVG

**Emission Level= Read Level+ Correct Factor**

<b>EUT:</b>	Smart Clock Camera	<b>Model:</b>	GF-H100base
<b>Temperature:</b>	25 °C	<b>Relative Humidity:</b>	55%
<b>Test Voltage:</b>	DC 3.6V		
<b>Ant. Pol.</b>	Horizontal		
<b>Test Mode:</b>	TX B Mode 2462MHz		
<b>Remark:</b>	N/A		

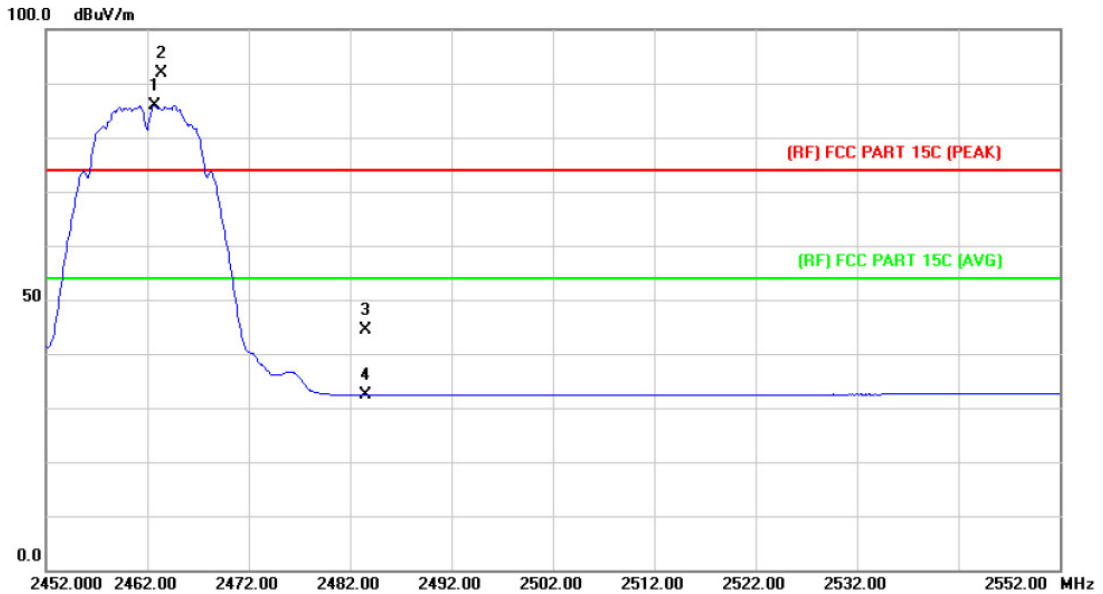

No.	Mk.	Freq. MHz	Reading Level dBuV	Correct Factor dB/m	Measure- ment dBuV/m	Limit dBuV/m	Over dB	Detector
1	*	2462.700	84.85	1.08	85.93	Fundamental Frequency		AVG
2	X	2463.400	90.85	1.08	91.93	Fundamental Frequency		peak
3		2483.500	43.32	1.17	44.49	74.00	-29.51	peak
4		2483.500	31.24	1.17	32.41	54.00	-21.59	AVG

**Emission Level= Read Level+ Correct Factor**

<b>EUT:</b>	Smart Clock Camera	<b>Model:</b>	GF-H100base
<b>Temperature:</b>	25 °C	<b>Relative Humidity:</b>	55%
<b>Test Voltage:</b>	DC 3.6V		
<b>Ant. Pol.</b>	Vertical		
<b>Test Mode:</b>	TX B Mode 2462MHz		
<b>Remark:</b>	N/A		

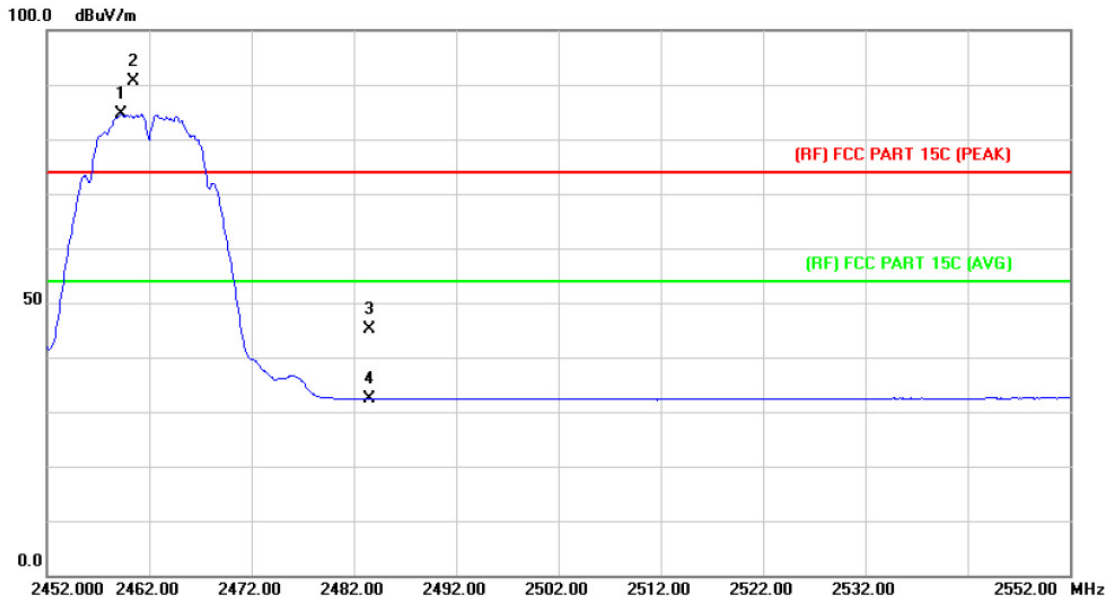

No.	Mk.	Freq.	Reading Level	Correct Factor	Measurement	Limit	Over	Detector
		MHz	dBuV	dB/m	dBuV/m	dBuV/m	dB	
1	*	2459.300	83.58	1.06	84.64	Fundamental Frequency		AVG
2	X	2460.500	89.45	1.06	90.51	Fundamental Frequency		peak
3		2483.500	44.06	1.17	45.23	74.00	-28.77	peak
4		2483.500	31.19	1.17	32.36	54.00	-21.64	AVG

Emission Level= Read Level+ Correct Factor

<b>EUT:</b>	Smart Clock Camera	<b>Model:</b>	GF-H100base
<b>Temperature:</b>	25 °C	<b>Relative Humidity:</b>	55%
<b>Test Voltage:</b>	DC 3.6V		
<b>Ant. Pol.</b>	Horizontal		
<b>Test Mode:</b>	TX G Mode 2412MHz		
<b>Remark:</b>	N/A		

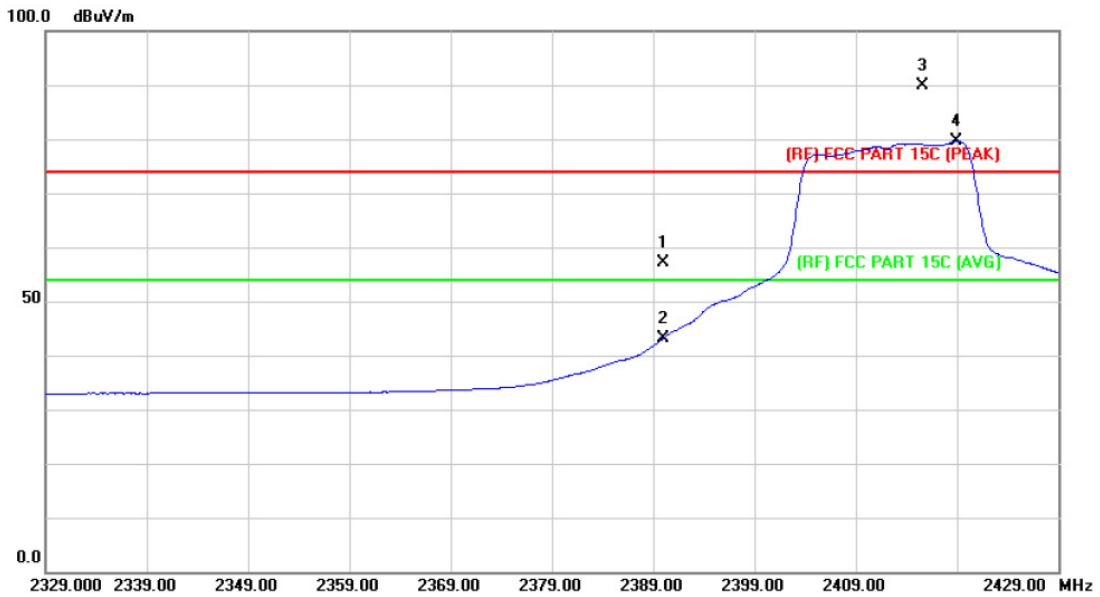

No.	Mk.	Freq. MHz	Reading Level dBuV	Correct Factor dB/m	Measure- ment dBuV/m	Limit dBuV/m	Over dB	Detector
1		2390.000	56.40	0.77	57.17	74.00	-16.83	peak
2		2390.000	42.43	0.77	43.20	54.00	-10.80	AVG
3	X	2415.600	88.91	0.88	89.79	Fundamental Frequency		peak
4	*	2418.900	78.67	0.89	79.56	Fundamental Frequency		AVG

Emission Level= Read Level+ Correct Factor

<b>EUT:</b>	Smart Clock Camera	<b>Model:</b>	GF-H100base
<b>Temperature:</b>	25 °C	<b>Relative Humidity:</b>	55%
<b>Test Voltage:</b>	DC 3.6V		
<b>Ant. Pol.</b>	Vertical		
<b>Test Mode:</b>	TX G Mode 2412MHz		
<b>Remark:</b>	N/A		

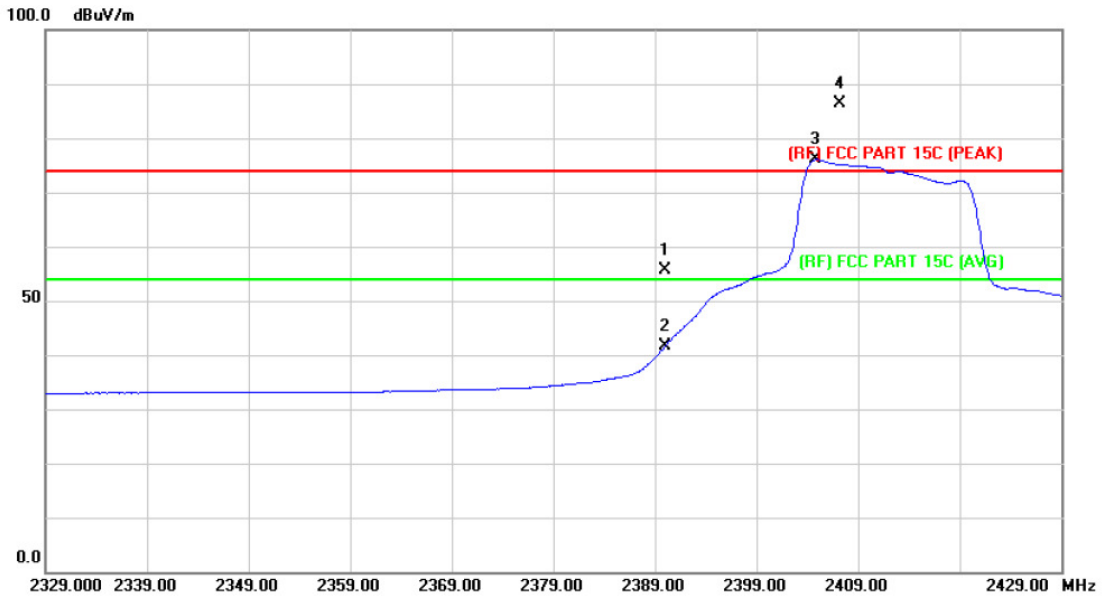

No.	Mk.	Freq. MHz	Reading Level dBuV	Correct Factor dB/m	Measure- ment dBuV/m	Limit dBuV/m	Over dB	Detector
1		2390.000	54.90	0.77	55.67	74.00	-18.33	peak
2		2390.000	40.85	0.77	41.62	54.00	-12.38	AVG
3	*	2404.800	75.20	0.84	76.04	Fundamental Frequency		AVG
4	X	2407.200	85.64	0.85	86.49	Fundamental Frequency		peak

**Emission Level= Read Level+ Correct Factor**

<b>EUT:</b>	Smart Clock Camera	<b>Model:</b>	GF-H100base
<b>Temperature:</b>	25 °C	<b>Relative Humidity:</b>	55%
<b>Test Voltage:</b>	DC 3.6V		
<b>Ant. Pol.</b>	Horizontal		
<b>Test Mode:</b>	TX G Mode 2462MHz		
<b>Remark:</b>	N/A		

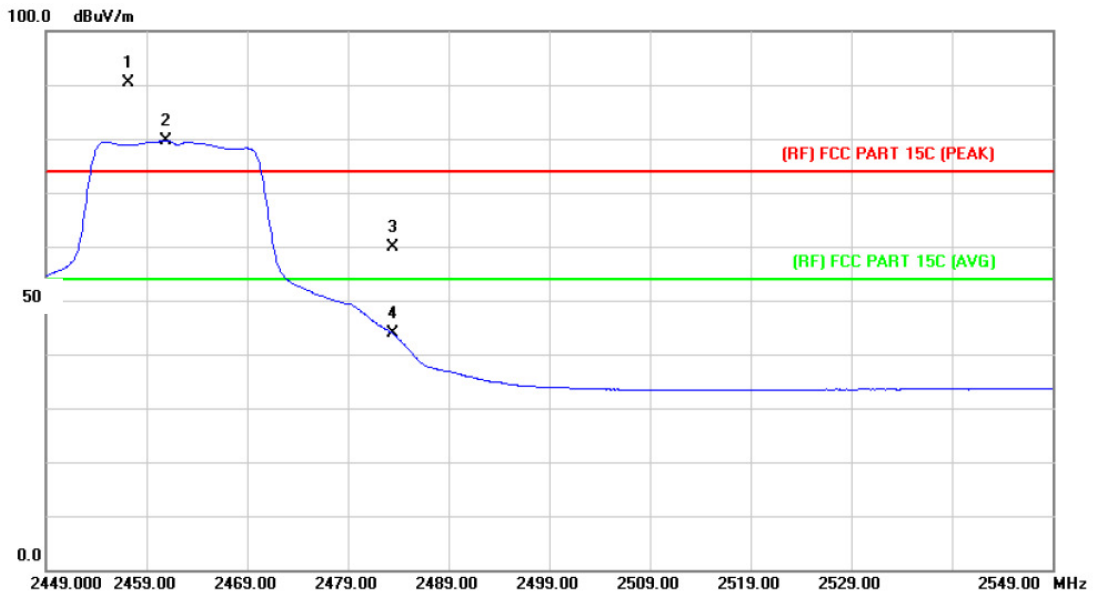

No.	Mk.	Freq. MHz	Reading Level dBuV	Correct Factor dB/m	Measure- ment dBuV/m	Limit dBuV/m	Over dB	Detector
1	X	2457.200	89.43	1.05	90.48	Fundamental Frequency		peak
2	*	2460.900	78.66	1.06	79.72	Fundamental Frequency		AVG
3		2483.500	58.70	1.17	59.87	74.00	-14.13	peak
4		2483.500	42.63	1.17	43.80	54.00	-10.20	AVG

Emission Level= Read Level+ Correct Factor

<b>EUT:</b>	Smart Clock Camera	<b>Model:</b>	GF-H100base
<b>Temperature:</b>	25 °C	<b>Relative Humidity:</b>	55%
<b>Test Voltage:</b>	DC 3.6V		
<b>Ant. Pol.</b>	Vertical		
<b>Test Mode:</b>	TX G Mode 2462MHz		
<b>Remark:</b>	N/A		

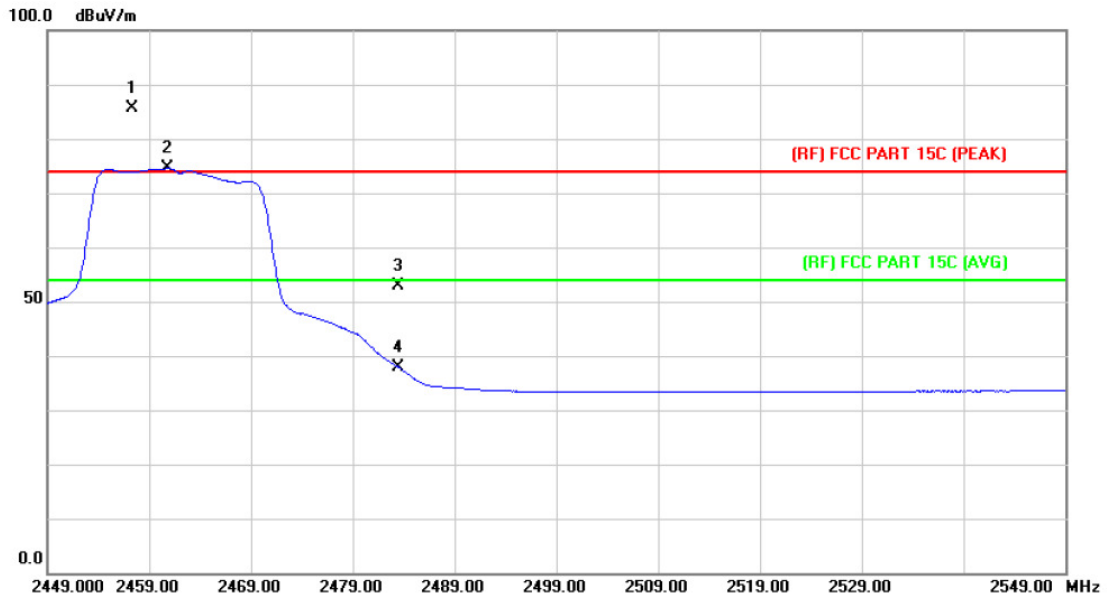

No.	Mk.	Freq. MHz	Reading Level dBuV	Correct Factor dB/m	Measure- ment dBuV/m	Limit dBuV/m	Over dB	Detector
1	X	2457.300	84.55	1.05	85.60	Fundamental Frequency		peak
2	*	2460.800	73.49	1.06	74.55	Fundamental Frequency		AVG
3		2483.500	51.67	1.17	52.84	74.00	-21.16	peak
4		2483.500	36.72	1.17	37.89	54.00	-16.11	AVG

Emission Level= Read Level+ Correct Factor

<b>EUT:</b>	Smart Clock Camera	<b>Model:</b>	GF-H100base
<b>Temperature:</b>	25 °C	<b>Relative Humidity:</b>	55%
<b>Test Voltage:</b>	DC 3.6V		
<b>Ant. Pol.</b>	Horizontal		
<b>Test Mode:</b>	TX N(HT20) Mode 2412MHz		
<b>Remark:</b>	N/A		

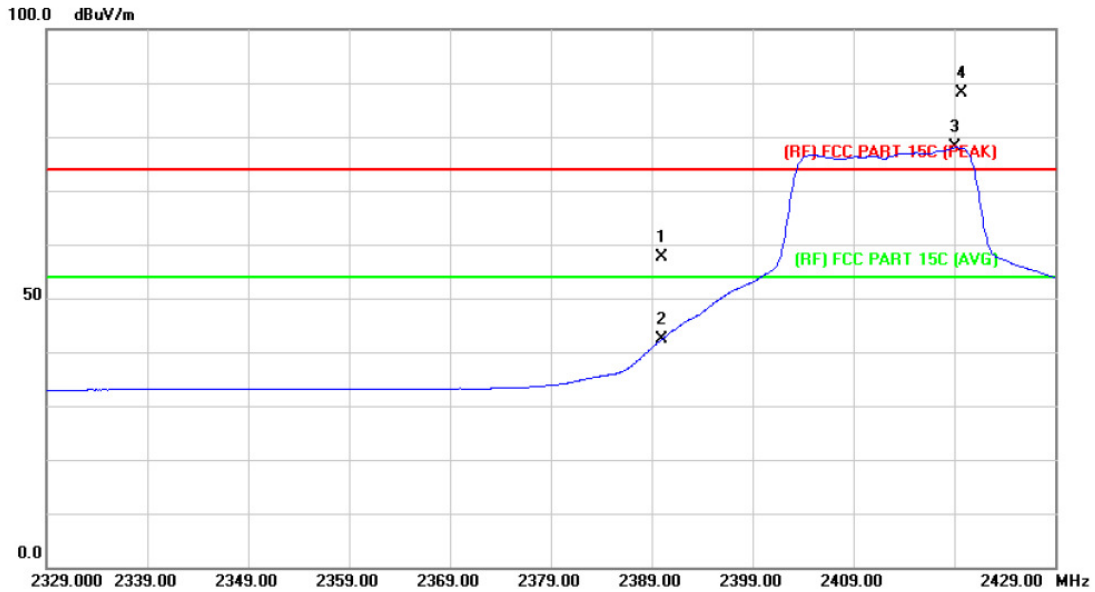

No.	Mk.	Freq. MHz	Reading Level dBuV	Correct Factor dB/m	Measure- ment dBuV/m	Limit dBuV/m	Over dB	Detector
1		2390.000	56.95	0.77	57.72	74.00	-16.28	peak
2		2390.000	41.57	0.77	42.34	54.00	-11.66	AVG
3	*	2419.000	77.14	0.89	78.03	Fundamental Frequency		AVG
4	X	2419.700	87.24	0.89	88.13	Fundamental Frequency		peak

Emission Level= Read Level+ Correct Factor

<b>EUT:</b>	Smart Clock Camera	<b>Model:</b>	GF-H100base
<b>Temperature:</b>	25 °C	<b>Relative Humidity:</b>	55%
<b>Test Voltage:</b>	DC 3.6V		
<b>Ant. Pol.</b>	Vertical		
<b>Test Mode:</b>	TX N(HT20) Mode 2412MHz		
<b>Remark:</b>	N/A		

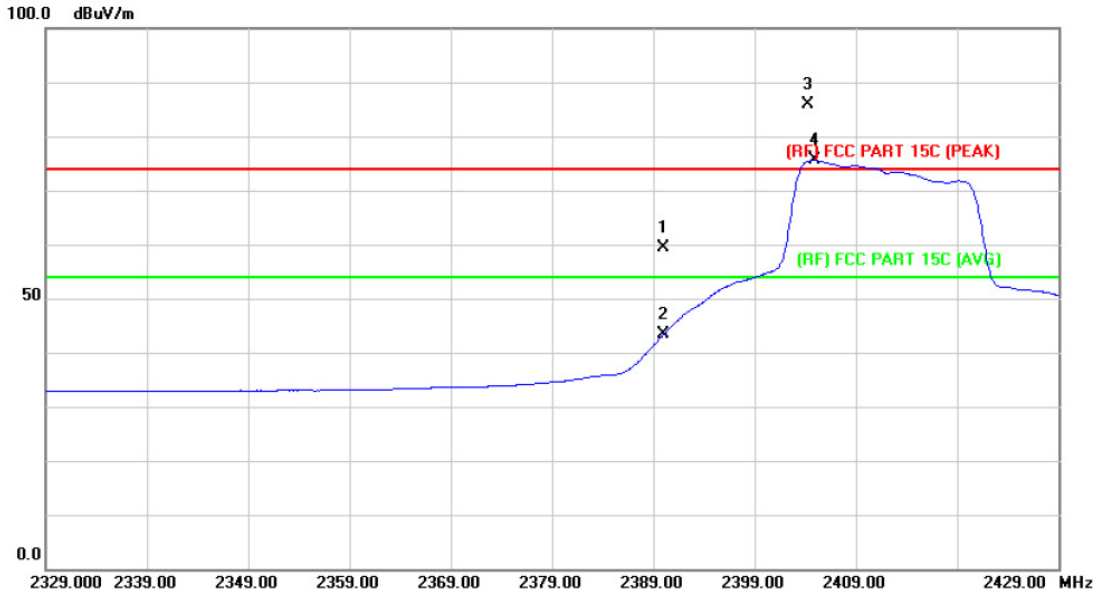

No.	Mk.	Freq. MHz	Reading Level dBuV	Correct Factor dB/m	Measurement dBuV/m	Limit dBuV/m	Over dB	Detector
1		2390.000	58.53	0.77	59.30	74.00	-14.70	peak
2		2390.000	42.56	0.77	43.33	54.00	-10.67	AVG
3	X	2404.300	84.96	0.83	85.79	Fundamental Frequency		peak
4	*	2404.900	74.76	0.84	75.60	Fundamental Frequency		AVG

**Emission Level= Read Level+ Correct Factor**

<b>EUT:</b>	Smart Clock Camera	<b>Model:</b>	GF-H100base
<b>Temperature:</b>	25 °C	<b>Relative Humidity:</b>	55%
<b>Test Voltage:</b>	DC 3.6V		
<b>Ant. Pol.</b>	Horizontal		
<b>Test Mode:</b>	TX N(HT20) Mode 2462MHz		
<b>Remark:</b>	N/A		

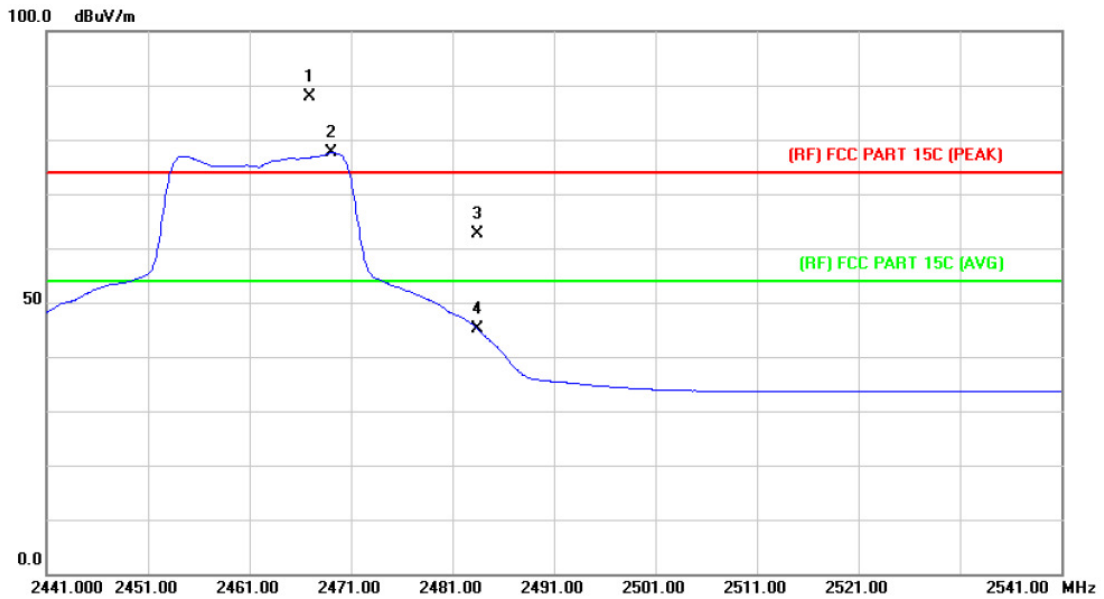

No.	Mk.	Freq. MHz	Reading Level dBuV	Correct Factor dB/m	Measure- ment dBuV/m	Limit dBuV/m	Over dB	Detector
1	X	2466.900	86.88	1.10	87.98			peak
2	*	2469.100	76.47	1.11	77.58			AVG
3		2483.500	61.45	1.17	62.62	74.00	-11.38	peak
4		2483.500	43.88	1.17	45.05	54.00	-8.95	AVG

Emission Level= Read Level+ Correct Factor

<b>EUT:</b>	Smart Clock Camera	<b>Model:</b>	GF-H100base
<b>Temperature:</b>	25 °C	<b>Relative Humidity:</b>	55%
<b>Test Voltage:</b>	DC 3.6V		
<b>Ant. Pol.</b>	Vertical		
<b>Test Mode:</b>	TX N(HT20) Mode 2462MHz		
<b>Remark:</b>	N/A		

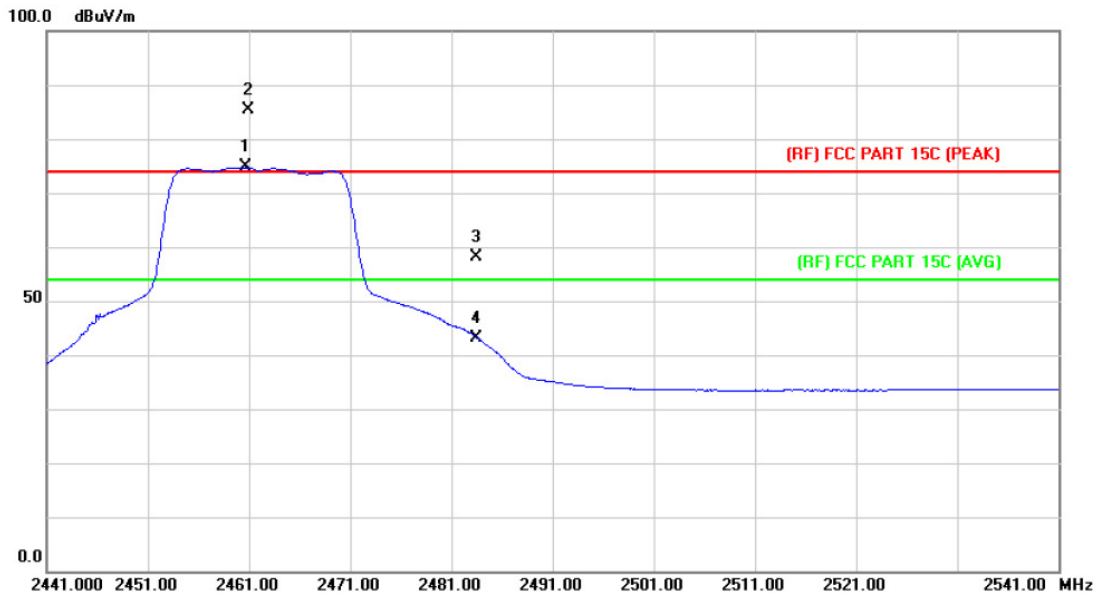

No.	Mk.	Freq.	Reading Level	Correct Factor	Measurement	Limit	Over	Detector
		MHz	dBuV	dB/m	dBuV/m	dBuV/m	dB	
1	*	2460.700	73.70	1.06	74.76	Fundamental Frequency		AVG
2	X	2460.900	84.27	1.06	85.33	Fundamental Frequency		peak
3		2483.500	57.06	1.17	58.23	74.00	-15.77	peak
4		2483.500	42.06	1.17	43.23	54.00	-10.77	AVG

Emission Level= Read Level+ Correct Factor

<b>EUT:</b>	Smart Clock Camera	<b>Model:</b>	GF-H100base
<b>Temperature:</b>	25 °C	<b>Relative Humidity:</b>	55%
<b>Test Voltage:</b>	DC 3.6V		
<b>Ant. Pol.</b>	Horizontal		
<b>Test Mode:</b>	TX N(HT40) Mode 2452MHz		
<b>Remark:</b>	N/A		

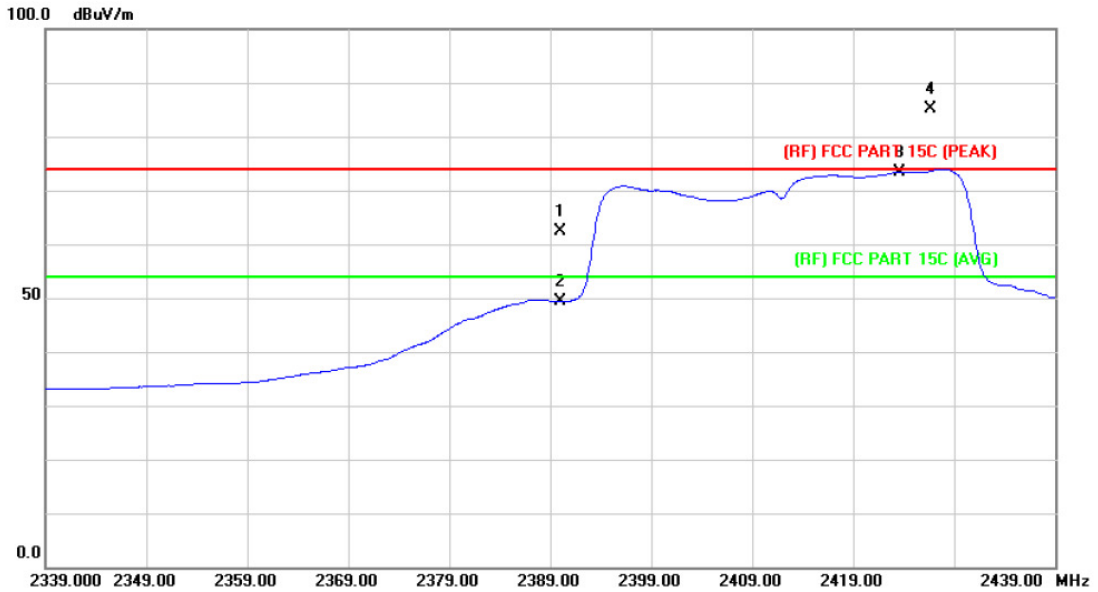

No.	Mk.	Freq.	Reading Level	Correct Factor	Measurement	Limit	Over	Detector
		MHz	dBuV	dB/m	dBuV/m	dBuV/m	dB	
1		2390.000	61.64	0.77	62.41	74.00	-11.59	peak
2		2390.000	48.60	0.77	49.37	54.00	-4.63	AVG
3	*	2423.600	72.51	0.91	73.42	Fundamental Frequency		AVG
4	X	2426.700	84.27	0.93	85.20	Fundamental Frequency		peak

Emission Level= Read Level+ Correct Factor

<b>EUT:</b>	Smart Clock Camera	<b>Model:</b>	GF-H100base
<b>Temperature:</b>	25 °C	<b>Relative Humidity:</b>	55%
<b>Test Voltage:</b>	DC 3.6V		
<b>Ant. Pol.</b>	Vertical		
<b>Test Mode:</b>	TX N(HT40) Mode 2422MHz		
<b>Remark:</b>	N/A		

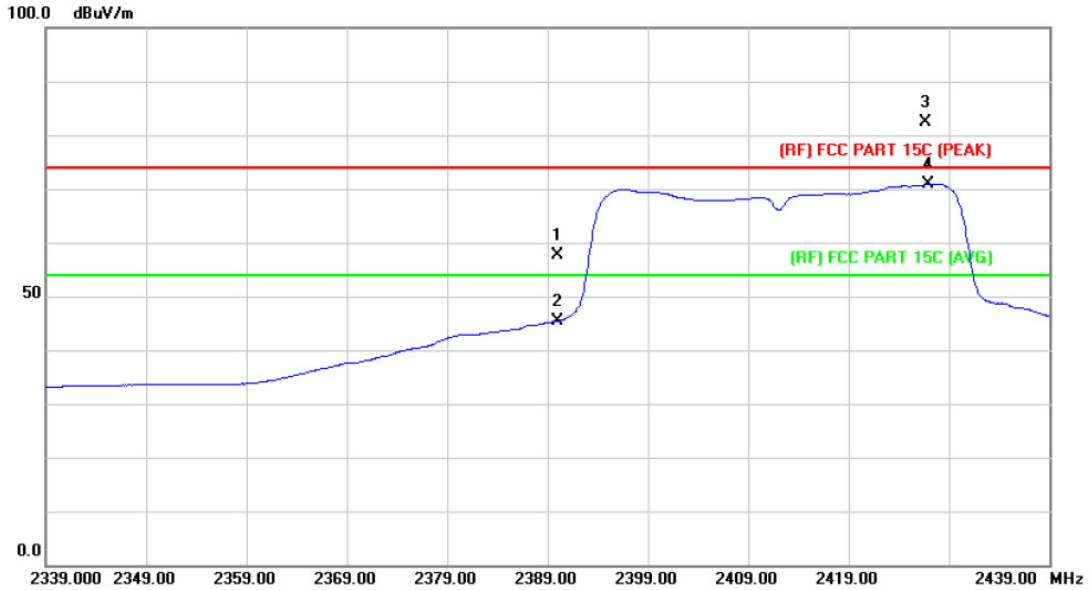

No.	Mk.	Freq. MHz	Reading Level dBuV	Correct Factor dB/m	Measure- ment dBuV/m	Limit dBuV/m	Over dB	Detector
1		2390.000	56.88	0.77	57.65	74.00	-16.35	peak
2		2390.000	44.69	0.77	45.46	54.00	-8.54	AVG
3	X	2426.700	81.47	0.93	82.40	Fundamental Frequency		peak
4	*	2426.900	69.97	0.93	70.90	Fundamental Frequency		AVG

Emission Level= Read Level+ Correct Factor

<b>EUT:</b>	Smart Clock Camera	<b>Model:</b>	GF-H100base
<b>Temperature:</b>	25 °C	<b>Relative Humidity:</b>	55%
<b>Test Voltage:</b>	DC 3.6V		
<b>Ant. Pol.</b>	Horizontal		
<b>Test Mode:</b>	TX N(HT40) Mode 2452MHz		
<b>Remark:</b>	N/A		

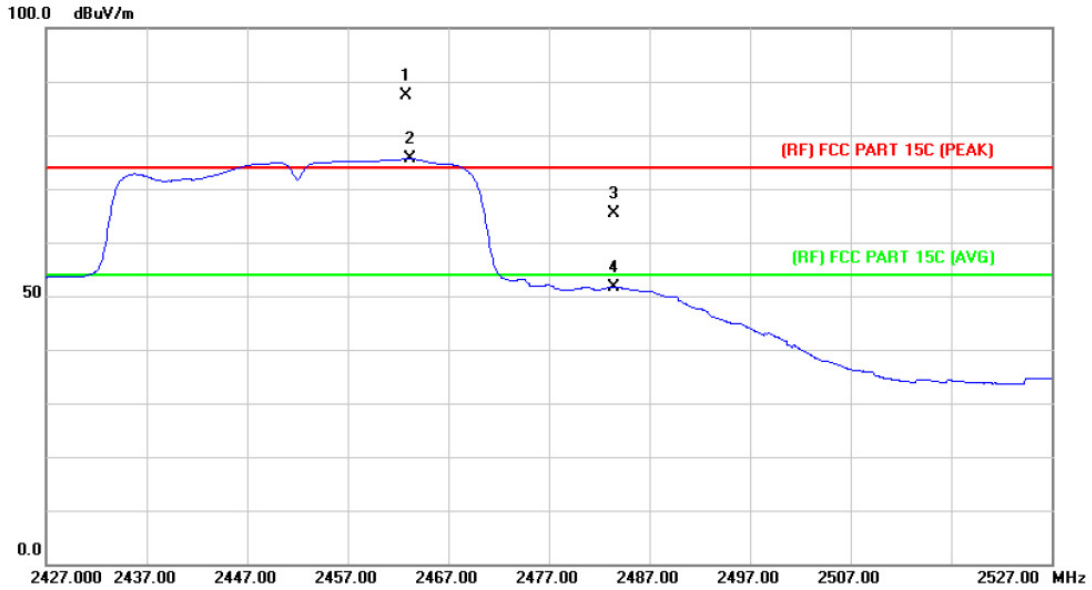

No.	Mk.	Freq. MHz	Reading Level dBuV	Correct Factor dB/m	Measure- ment dBuV/m	Limit dBuV/m	Over dB	Detector
1	X	2462.800	86.19	1.08	87.27	Fundamental Frequency		peak
2	*	2463.200	74.59	1.08	75.67	Fundamental Frequency		AVG
3		2483.500	64.30	1.17	65.47	74.00	-8.53	peak
4		2483.500	50.48	1.17	51.65	54.00	-2.35	AVG

Emission Level= Read Level+ Correct Factor

<b>EUT:</b>	Smart Clock Camera	<b>Model:</b>	GF-H100base
<b>Temperature:</b>	25 °C	<b>Relative Humidity:</b>	55%
<b>Test Voltage:</b>	DC 3.6V		
<b>Ant. Pol.</b>	Vertical		
<b>Test Mode:</b>	TX N(HT40) Mode 2452MHz		
<b>Remark:</b>	N/A		

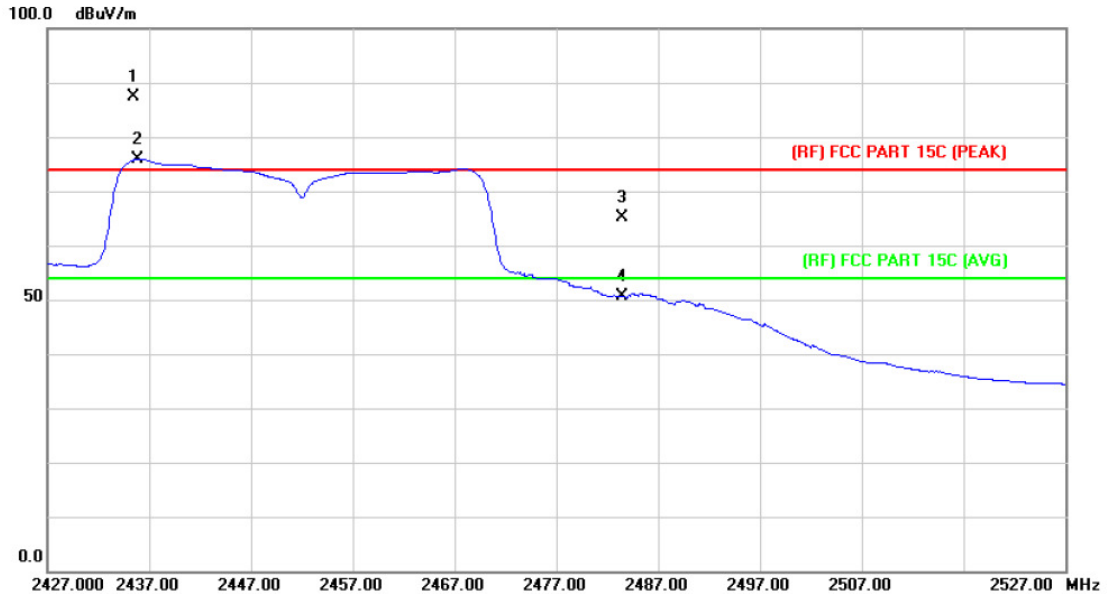

No.	Mk.	Freq. MHz	Reading Level dBuV	Correct Factor dB/m	Measure- ment dBuV/m	Limit dBuV/m	Over dB	Detector
1	X	2435.500	86.31	0.97	87.28	Fundamental Frequency		peak
2	*	2435.800	74.95	0.97	75.92	Fundamental Frequency		AVG
3		2483.500	64.01	1.17	65.18	74.00	-8.82	peak
4		2483.500	49.47	1.17	50.64	54.00	-3.36	AVG

**Emission Level= Read Level+ Correct Factor**

**(2) Conducted Test**

<b>EUT:</b>	Smart Clock Camera	<b>Model:</b>	GF-H100base
<b>Temperature:</b>	25 °C	<b>Relative Humidity:</b>	55%
<b>Test Voltage:</b>	DC 3.6V		
<b>Test Mode:</b>	TX B Mode 2412MHz / TX B Mode 2462MHz		
<b>Remark:</b>	The EUT is programed in continuously transmitting mode		

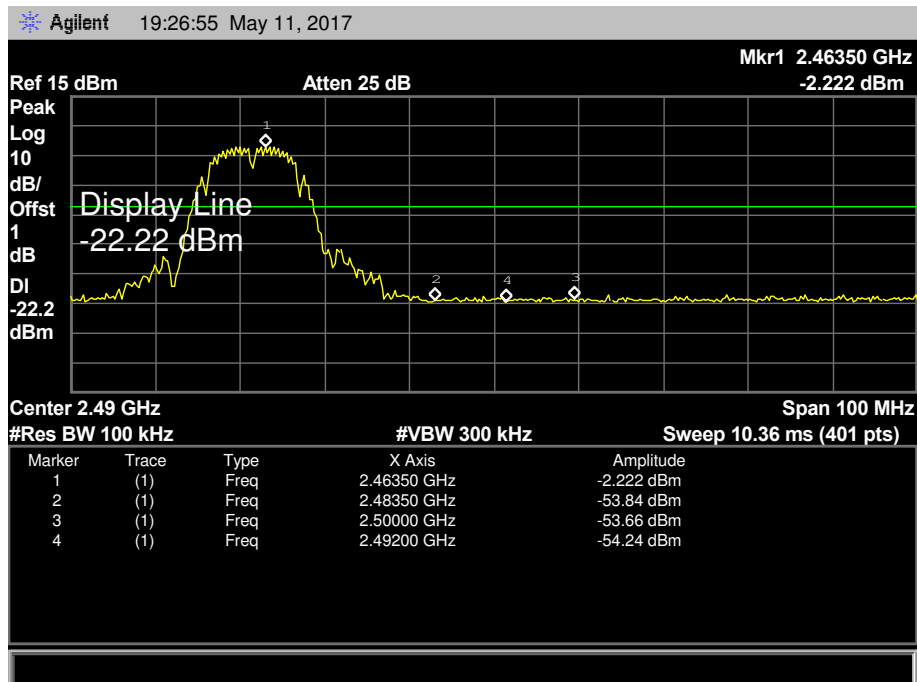
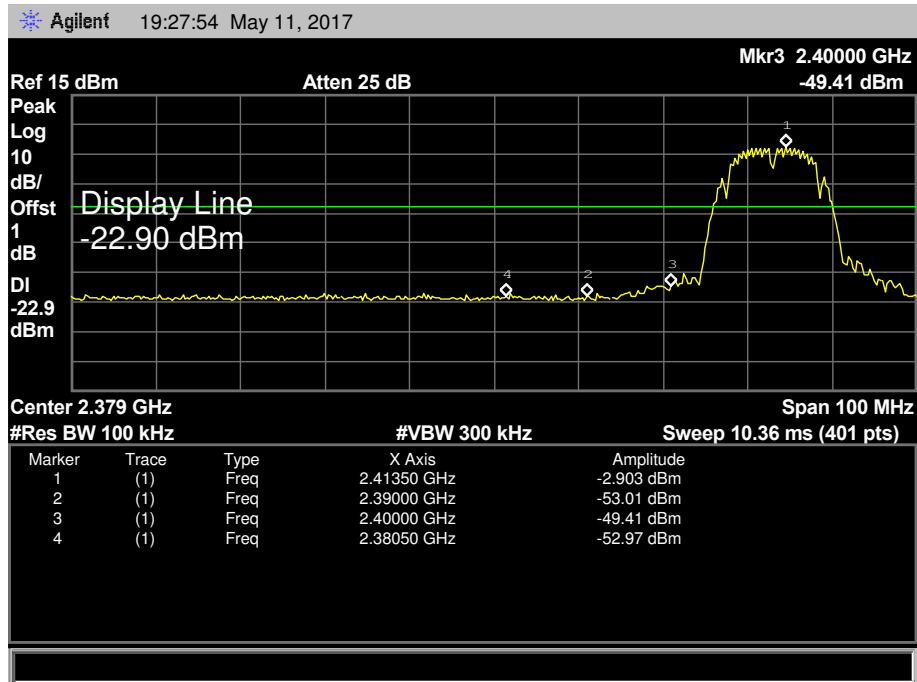

<b>EUT:</b>	Smart Clock Camera	<b>Model:</b>	GF-H100base
<b>Temperature:</b>	25 °C	<b>Relative Humidity:</b>	55%
<b>Test Voltage:</b>	DC 3.6V		
<b>Test Mode:</b>	TX G Mode 2412MHz / TX G Mode 2462MHz		
<b>Remark:</b>	The EUT is programed in continuously transmitting mode		

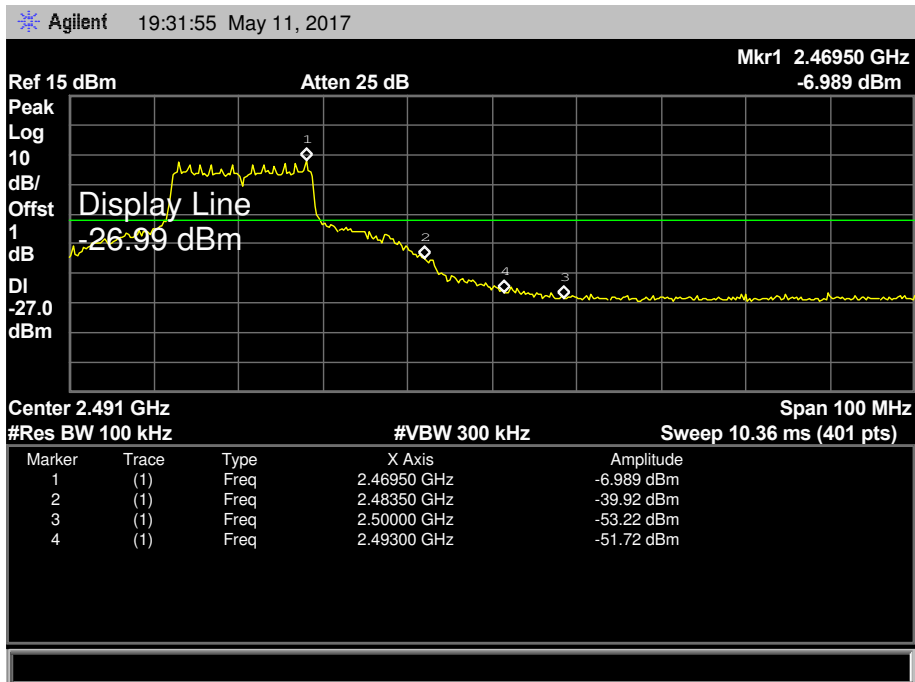
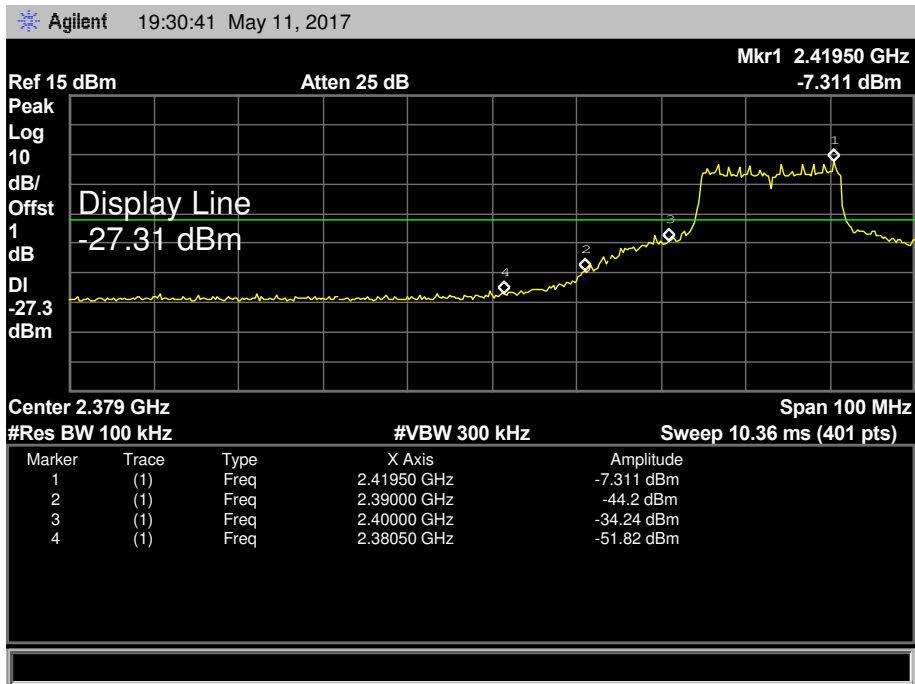

<b>EUT:</b>	Smart Clock Camera	<b>Model:</b>	GF-H100base
<b>Temperature:</b>	25 °C	<b>Relative Humidity:</b>	55%
<b>Test Voltage:</b>	DC 3.6V		
<b>Test Mode:</b>	TX N(HT20) Mode 2412MHz / TX N(HT20) Mode 2462MHz		
<b>Remark:</b>	The EUT is programed in continuously transmitting mode		

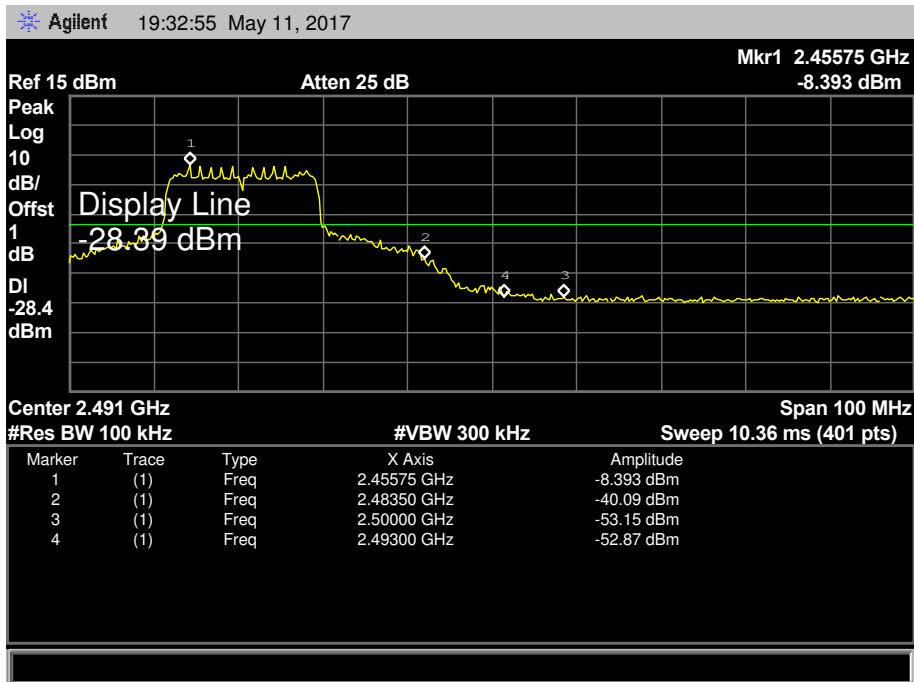
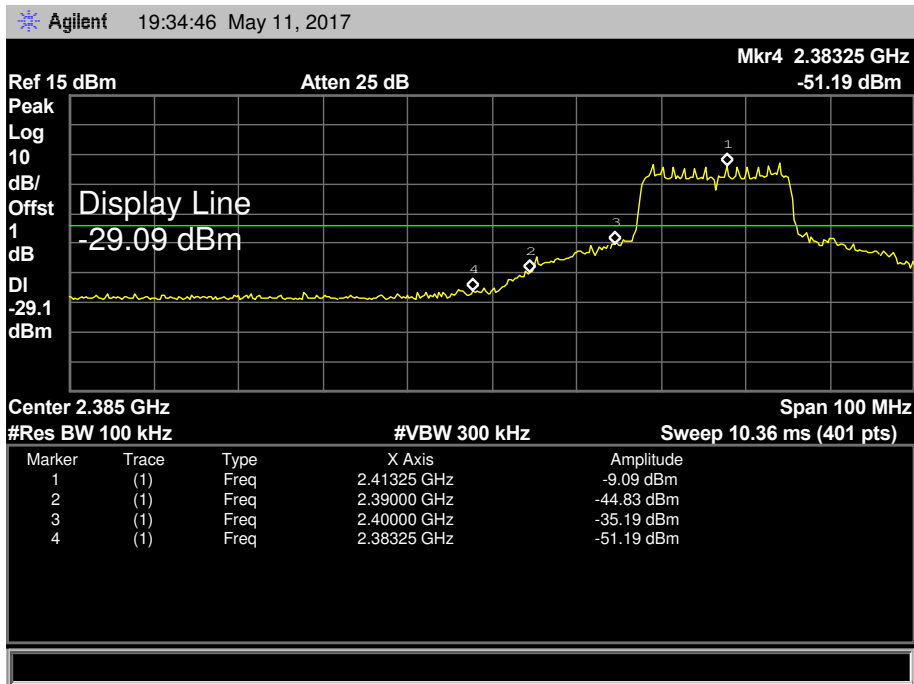

<b>EUT:</b>	Smart Clock Camera	<b>Model:</b>	GF-H100base
<b>Temperature:</b>	25 °C	<b>Relative Humidity:</b>	55%
<b>Test Voltage:</b>	DC 3.6V		
<b>Test Mode:</b>	TX N(HT40) Mode 2422MHz / TX N(HT40) Mode 2452MHz		
<b>Remark:</b>	The EUT is programed in continuously transmitting mode		

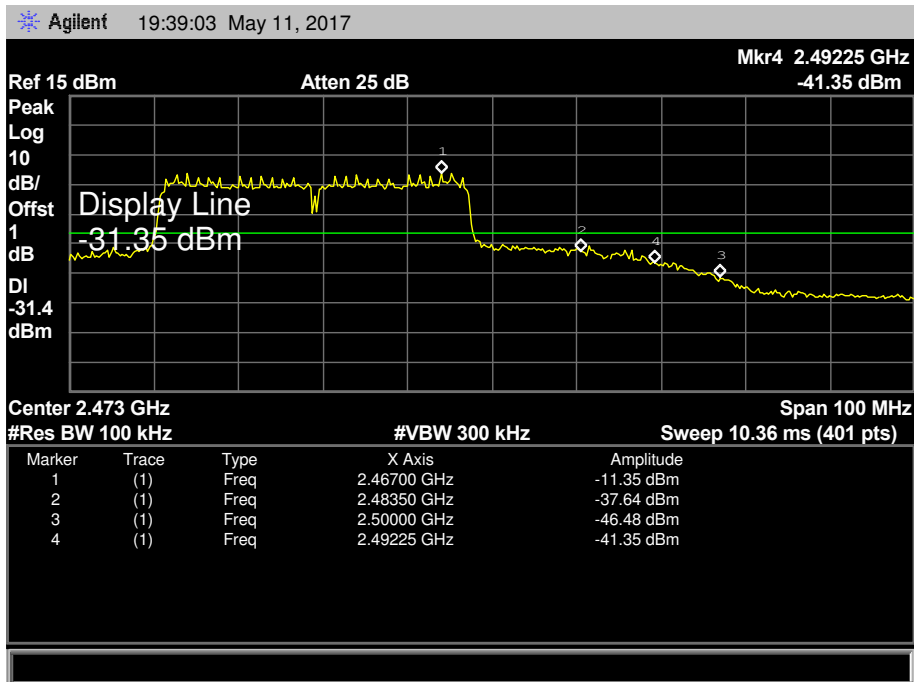
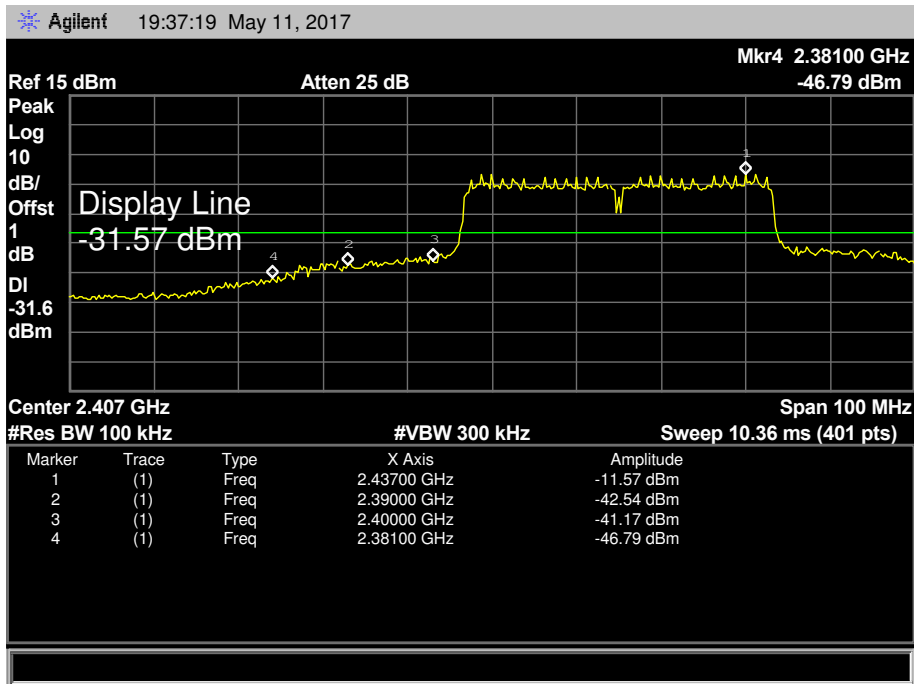

## 7. Bandwidth Test

### 7.1 Test Standard and Limit

#### 7.1.1 Test Standard

FCC Part 15.247 (a)(2)

#### 7.1.2 Test Limit

FCC Part 15 Subpart C(15.247)/RSS-210		
Test Item	Limit	Frequency Range(MHz)
Bandwidth	$\geq 500$ KHz (6dB bandwidth)	2400~2483.5

### 7.2 Test Setup

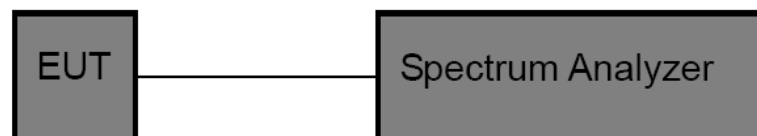

### 7.3 Test Procedure

- (1) The EUT was directly connected to the spectrum analyzer and antenna output port as show in the block diagram above.
- (2) The bandwidth is measured at an amplitude level reduced 6dB from the reference level. The reference level is the level of the highest amplitude signal observed from the transmitter at the fundamental frequency. Once the reference level is established, the equipment is conditioned with typical modulating signal to produce the worst -case (i.e the widest) bandwidth.
- (3) Measure the channel separation the spectrum analyzer was set to Resolution Bandwidth:100 kHz, and Video Bandwidth:300 kHz, Detector: Peak, Sweep Time set auto.

### 7.4 EUT Operating Condition

The EUT was set to continuously transmitting in each mode and low, Digital photo framesdle and high channel for the test.

### 7.5 Test Data

<b>EUT:</b>	Smart Clock Camera	<b>Model:</b>	GF-H100base
<b>Temperature:</b>	25 °C	<b>Relative Humidity:</b>	55%
<b>Test Voltage:</b>	DC 3.6V		
<b>Test Mode:</b>	TX 802.11B Mode		
<b>Channel frequency (MHz)</b>	<b>6dB Bandwidth (MHz)</b>	<b>99% Bandwidth (MHz)</b>	<b>Limit (MHz)</b>
2412	10.084	14.6322	≥0.5
2437	10.070	14.5797	
2462	10.069	14.5493	

**802.11B Mode**

**2412 MHz**

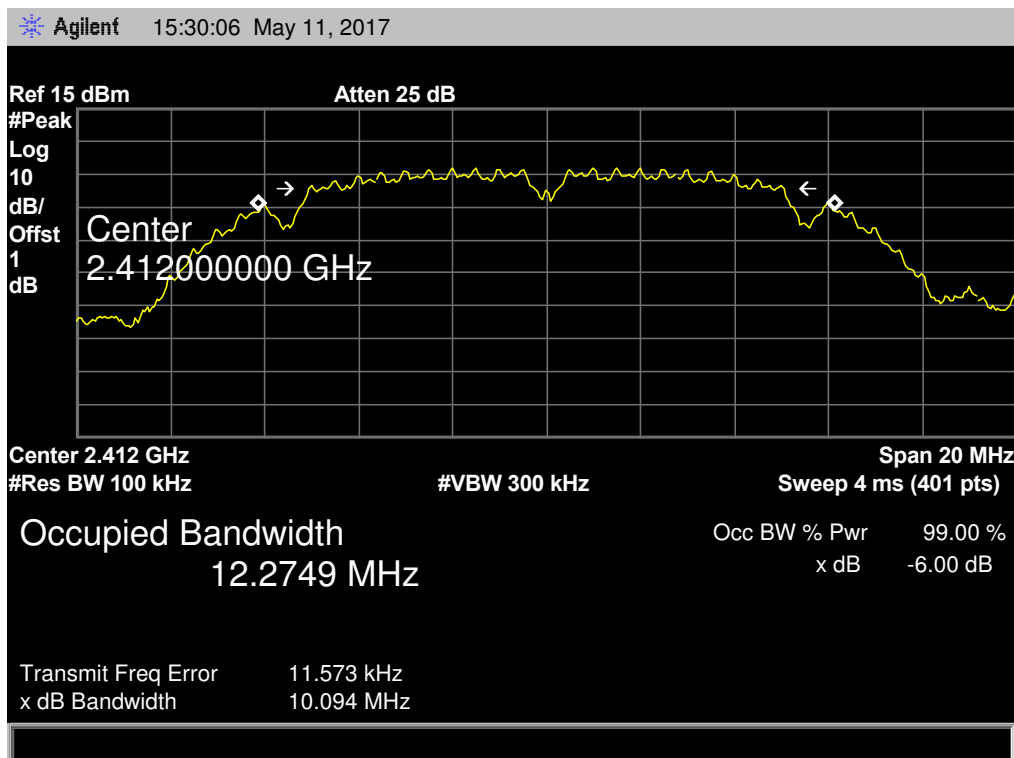

**802.11B Mode**

**2437 MHz**

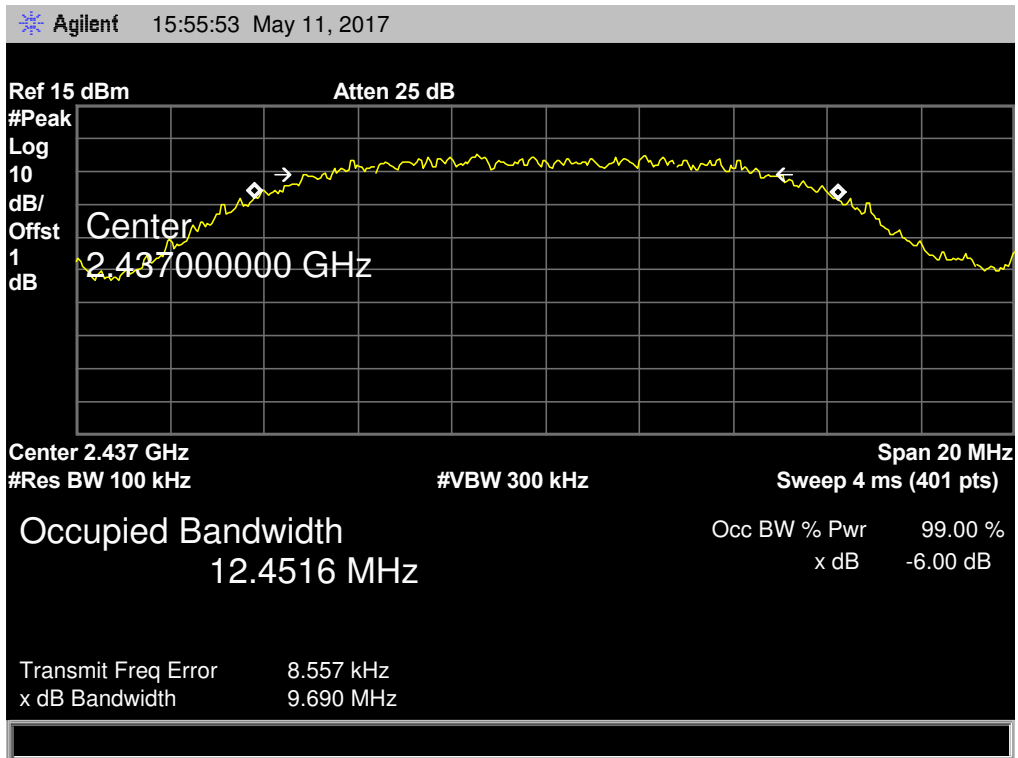

**802.11B Mode**

**2462 MHz**

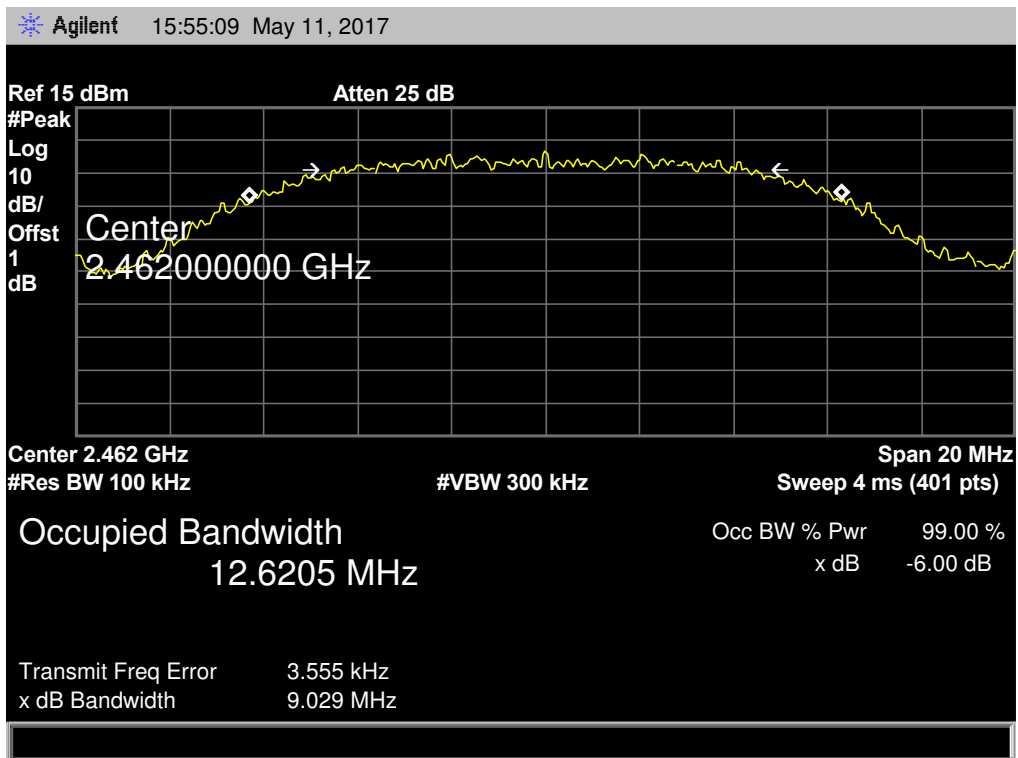

<b>EUT:</b>	Smart Clock Camera	<b>Model:</b>	GF-H100base
<b>Temperature:</b>	25 °C	<b>Relative Humidity:</b>	55%
<b>Test Voltage:</b>	DC 3.6V		
<b>Test Mode:</b>	TX 802.11G Mode		
<b>Channel frequency (MHz)</b>	<b>6dB Bandwidth (MHz)</b>	<b>99% Bandwidth (MHz)</b>	<b>Limit (MHz)</b>
2412	16.573	16.4726	>=0.5
2437	16.593	16.5164	
2462	15.692	16.3885	

**802.11G Mode**

**2412 MHz**

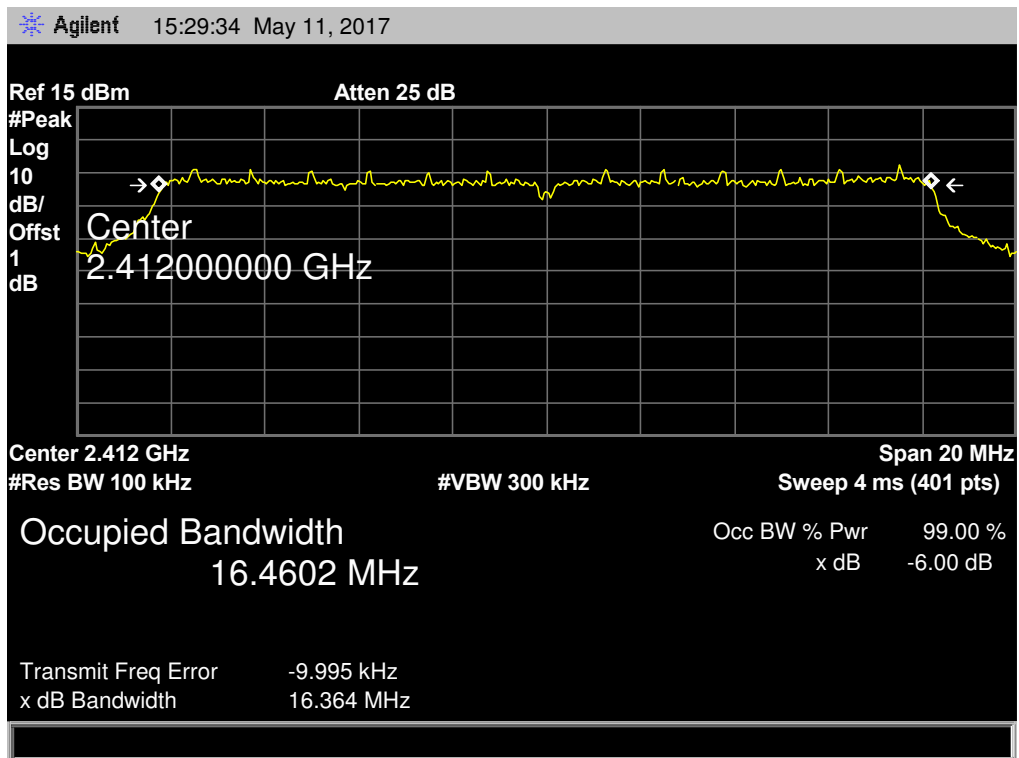

**802.11G Mode**

**2437 MHz**

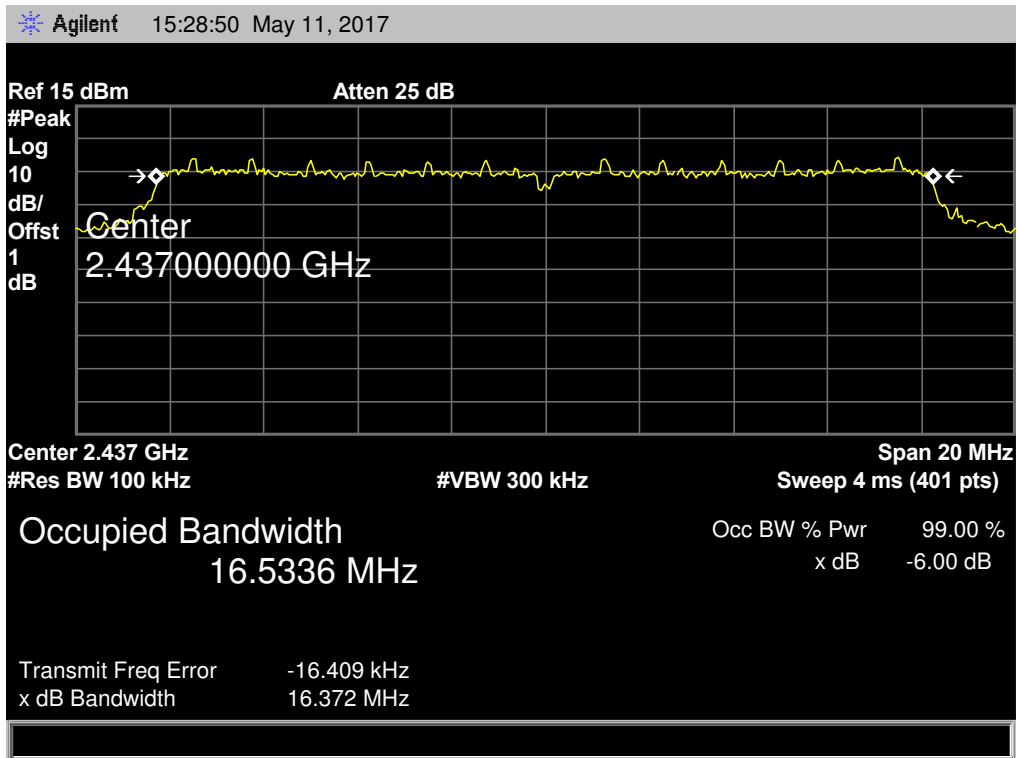

**802.11G Mode**

**2462 MHz**

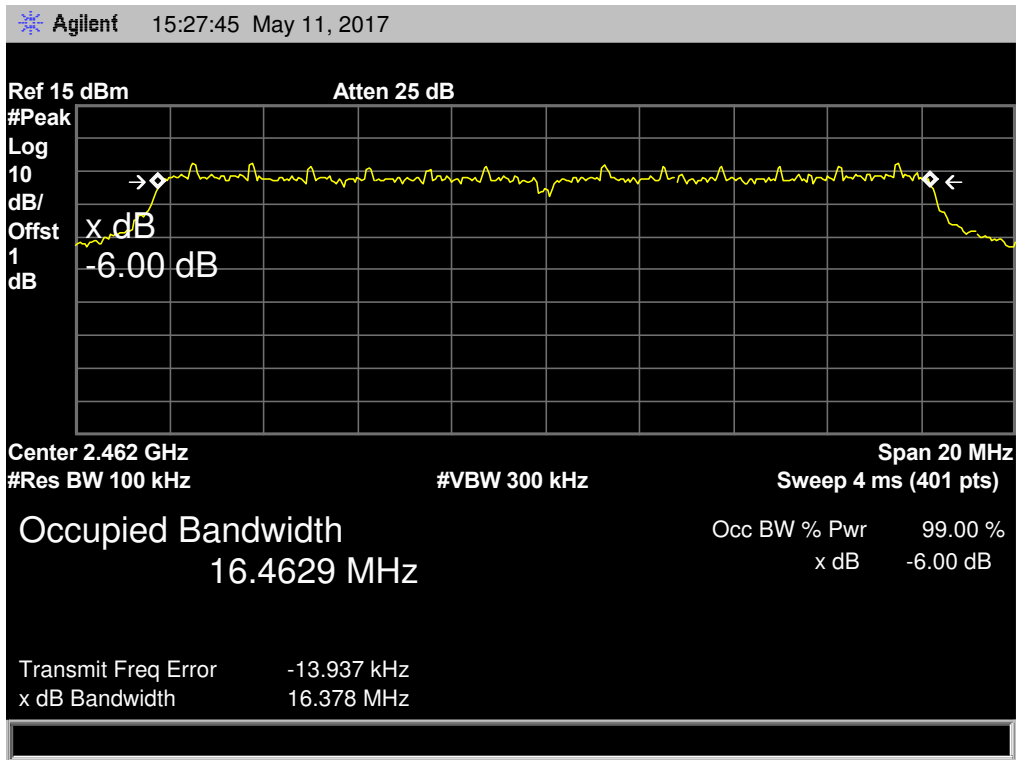

<b>EUT:</b>	Smart Clock Camera	<b>Model:</b>	GF-H100base
<b>Temperature:</b>	25 °C	<b>Relative Humidity:</b>	55%
<b>Test Voltage:</b>	DC 3.6V		
<b>Test Mode:</b>	TX 802.11N(HT20) Mode		
<b>Channel frequency (MHz)</b>	<b>6dB Bandwidth (MHz)</b>	<b>99% Bandwidth (MHz)</b>	<b>Limit (MHz)</b>
2412	17.840	17.6397	≥0.5
2437	17.858	17.6415	
2462	17.823	17.6304	

**802.11N(HT20) Mode**

**2412 MHz**

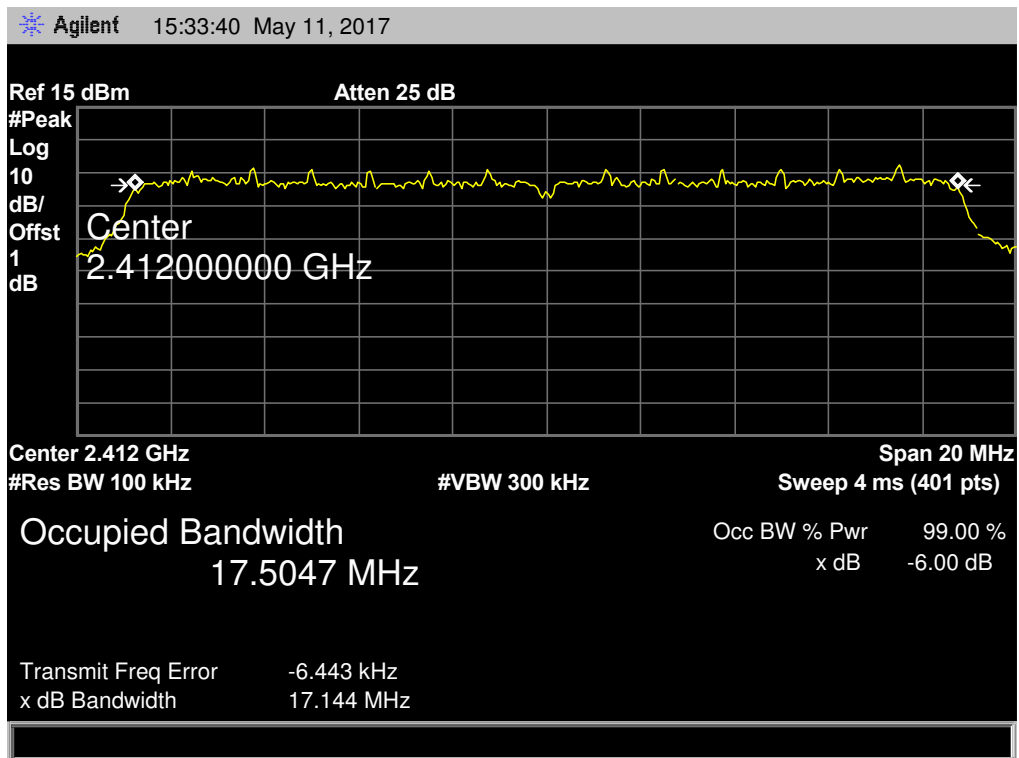

**802.11N(HT20) Mode**

**2437 MHz**

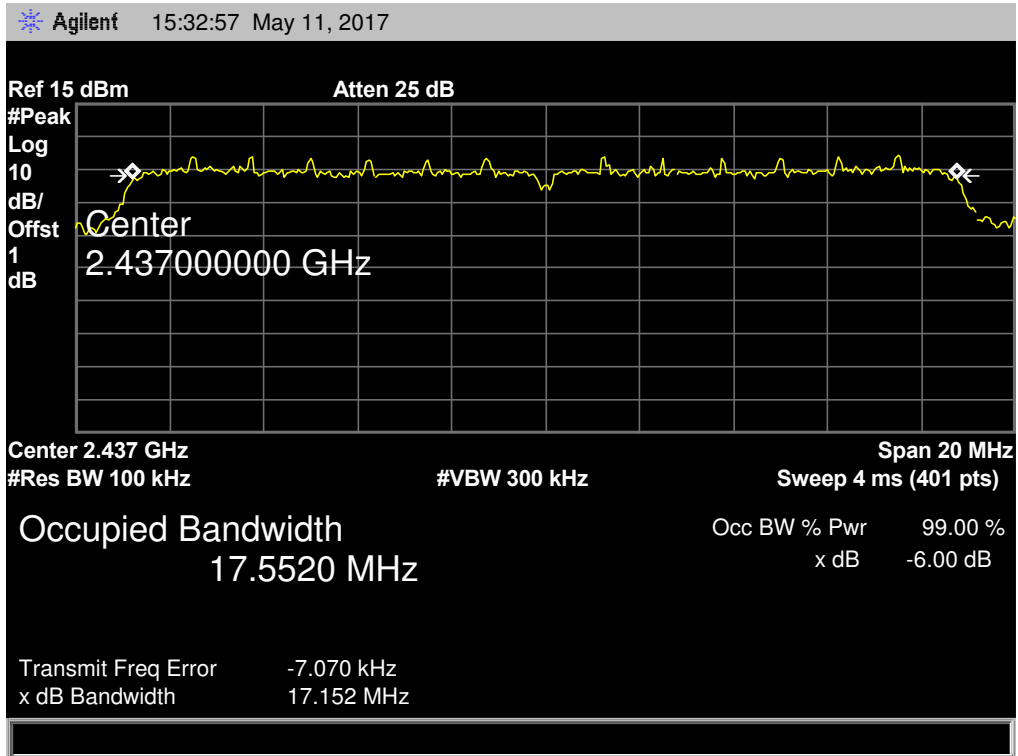

**802.11N(HT20) Mode**

**2462 MHz**

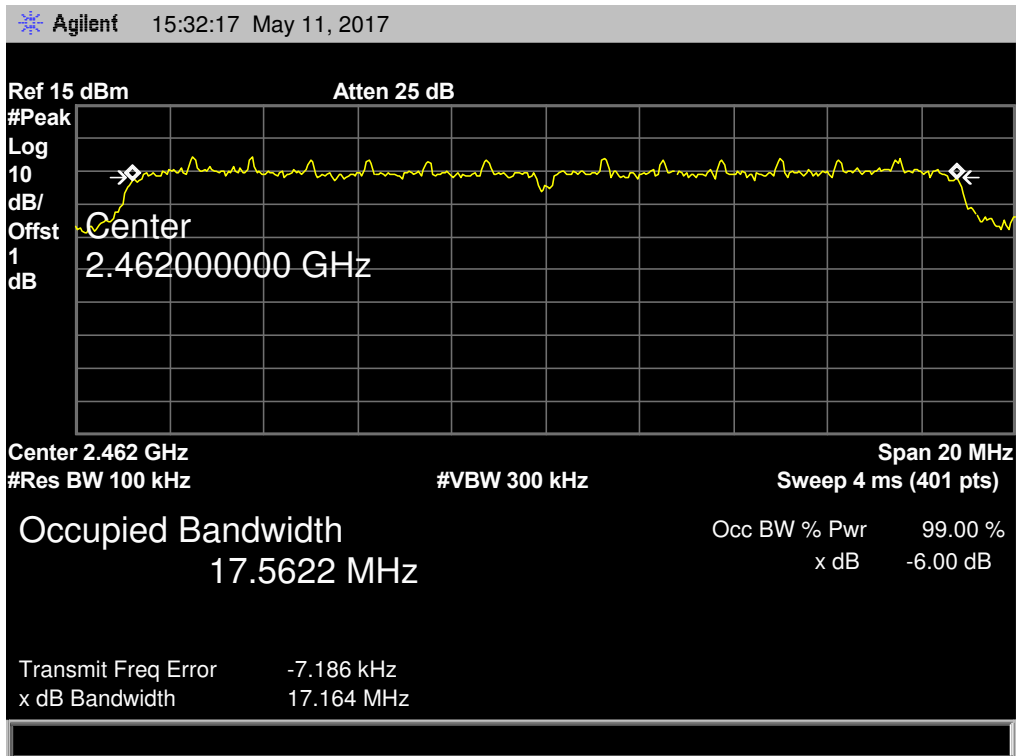

<b>EUT:</b>	Smart Clock Camera	<b>Model:</b>	GF-H100base
<b>Temperature:</b>	25 °C	<b>Relative Humidity:</b>	55%
<b>Test Voltage:</b>	DC 3.6V		
<b>Test Mode:</b>	TX 802.11N(HT40) Mode		
<b>Channel frequency (MHz)</b>	<b>6dB Bandwidth (MHz)</b>	<b>99% Bandwidth (MHz)</b>	<b>Limit (MHz)</b>
2422	36.314	35.7600	≥0.5
2437	36.547	36.0023	
2452	36.513	36.0041	

**802.11N(HT40) Mode**

**2422 MHz**

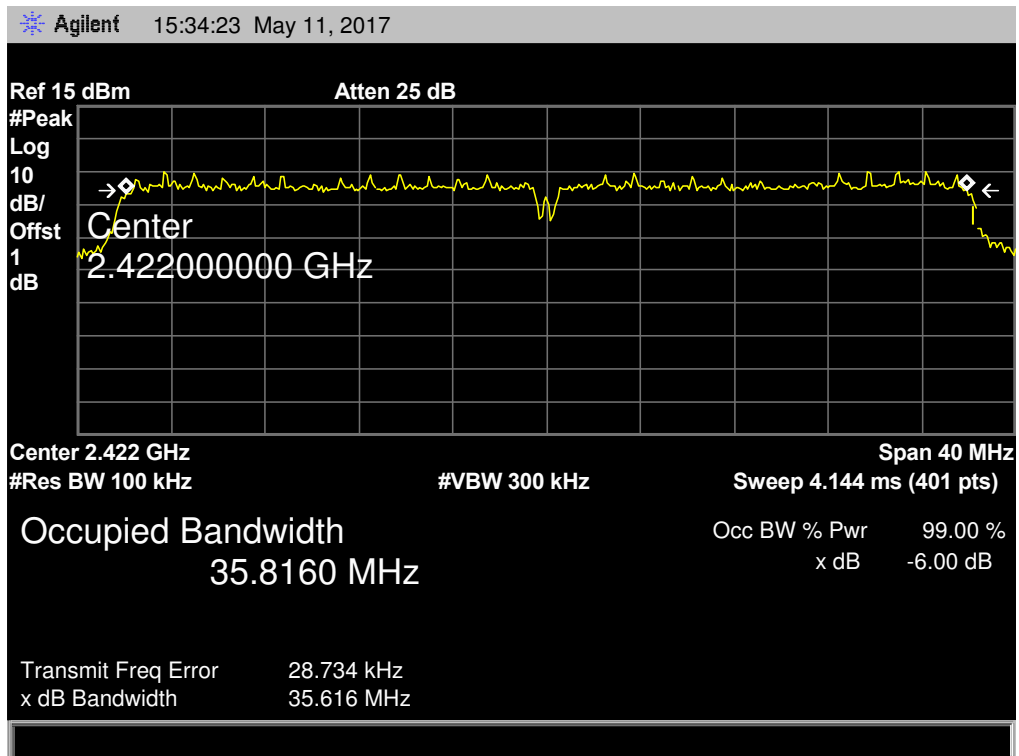

**802.11N(HT40) Mode**

**2437 MHz**

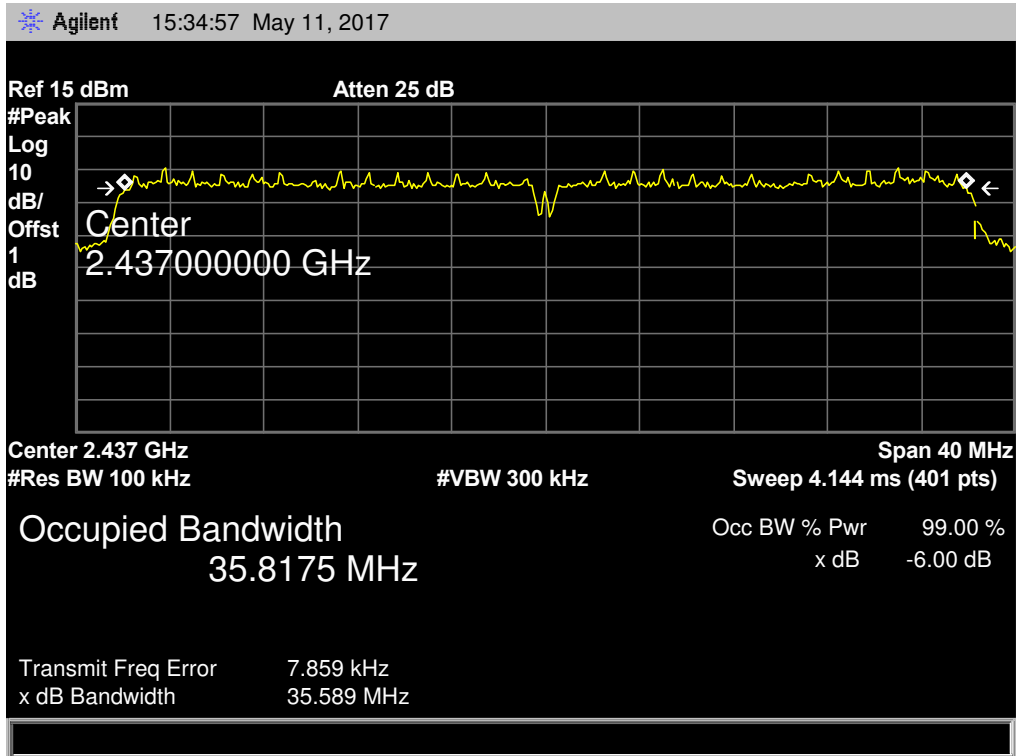

**802.11N(HT40) Mode**

**2452 MHz**

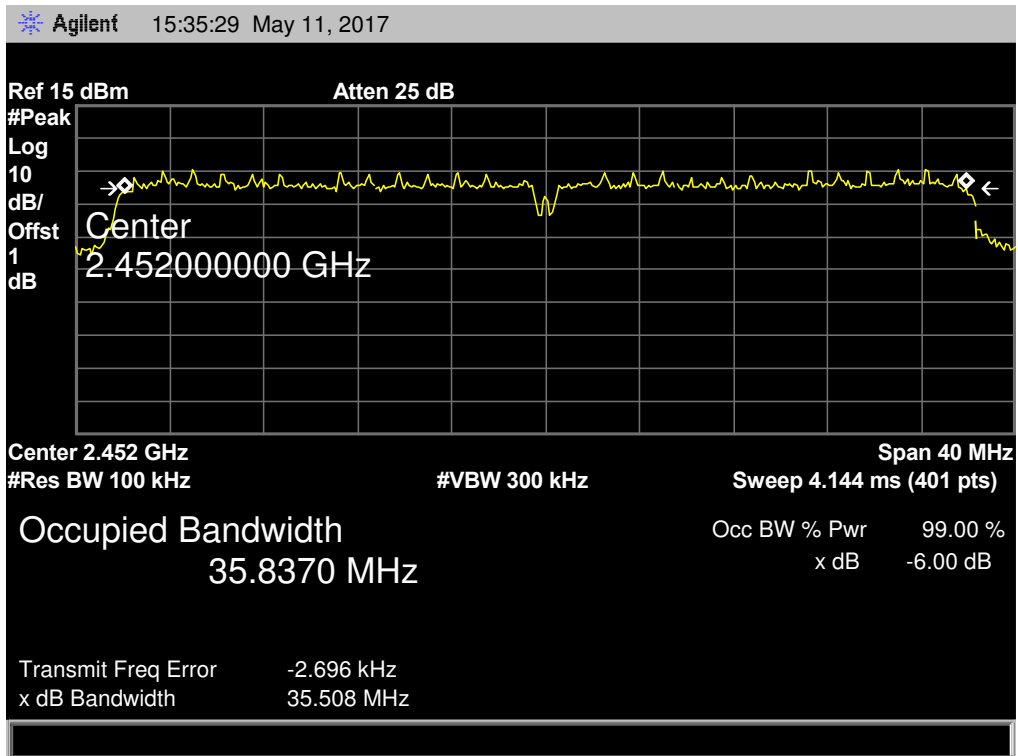

## 8. Peak Output Power Test

### 8.1 Test Standard and Limit

#### 8.1.1 Test Standard

FCC Part 15.247 (b)

#### 8.1.2 Test Limit

FCC Part 15 Subpart C(15.247)/RSS-210		
Test Item	Limit	Frequency Range(MHz)
Peak Output Power	1 Watt or 30 dBm	2400~2483.5

### 8.2 Test Setup

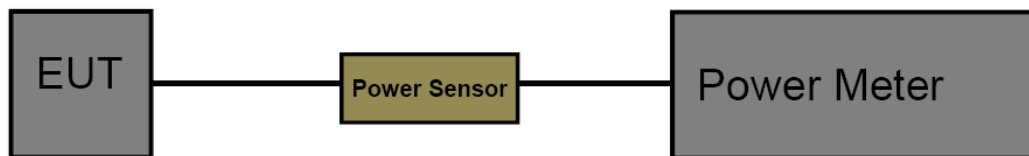

### 8.3 Test Procedure

The measurement is according to section 9.1.2 of KDB 558074 D01 DTS Meas Guidance v04. The EUT was connected to RF power meter via a broadband power sensor as show the block above. The power sensor video bandwidth is greater than or equal to the DTS bandwidth of the equipment.

### 8.4 EUT Operating Condition

The EUT was set to continuously transmitting in the max power during the test.

### 8.5 Test Data

<b>EUT:</b>	Smart Clock Camera	<b>Model:</b>	GF-H100base
<b>Temperature:</b>	25 °C	<b>Relative Humidity:</b>	55%
<b>Test Voltage:</b>	DC 3.6V		
Mode	Channel frequency (MHz)	Test Result (dBm)	Limit (dBm)
802.11b	2412	9.26	30
	2437	9.28	
	2462	9.24	
802.11g	2412	9.15	
	2437	9.13	
	2462	9.17	
802.11n (HT20)	2412	9.12	
	2437	9.11	
	2462	9.14	
802.11n (HT40)	2422	9.02	
	2437	9.05	
	2452	9.04	
<b>Result: PASS</b>			

Duty Cycle		
Mode	Channel frequency (MHz)	Test Result
802.11b	2412	>98%
	2437	
	2462	
802.11g	2412	
	2437	
	2462	
802.11n (HT20)	2412	
	2437	
	2462	
802.11n (HT40)	2422	
	2437	
	2452	
Please see below plots		

**802.11 B Mode 2437 MHz**

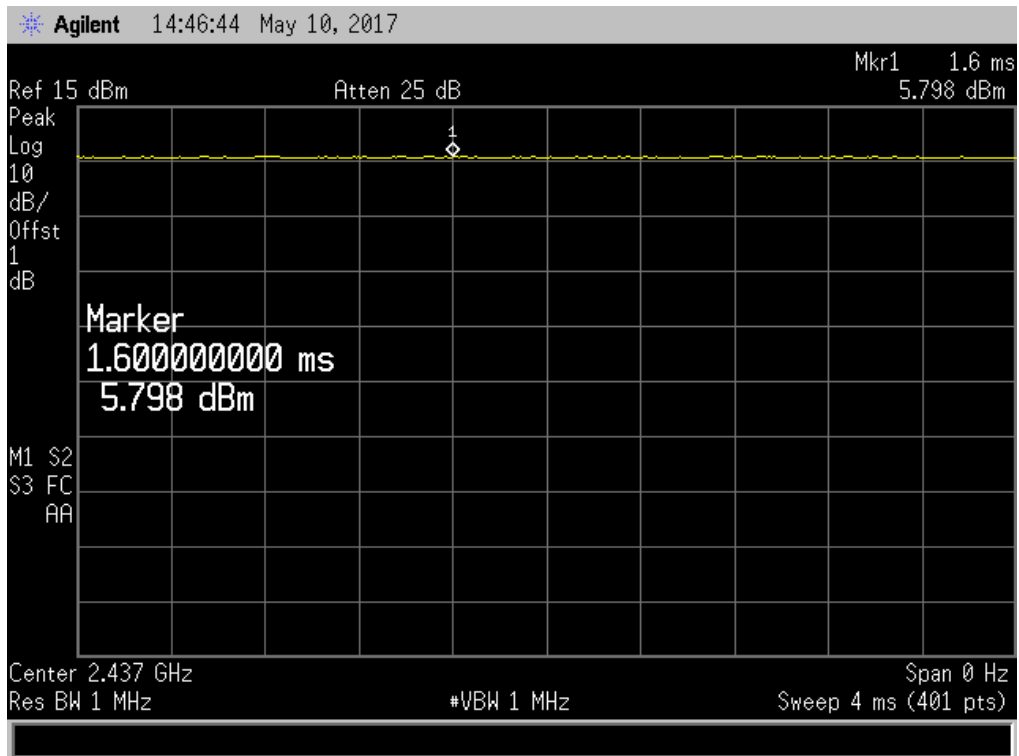

**802.11 G Mode 2437 MHz**



**802.11 N(HT20) Mode 2437 MHz**

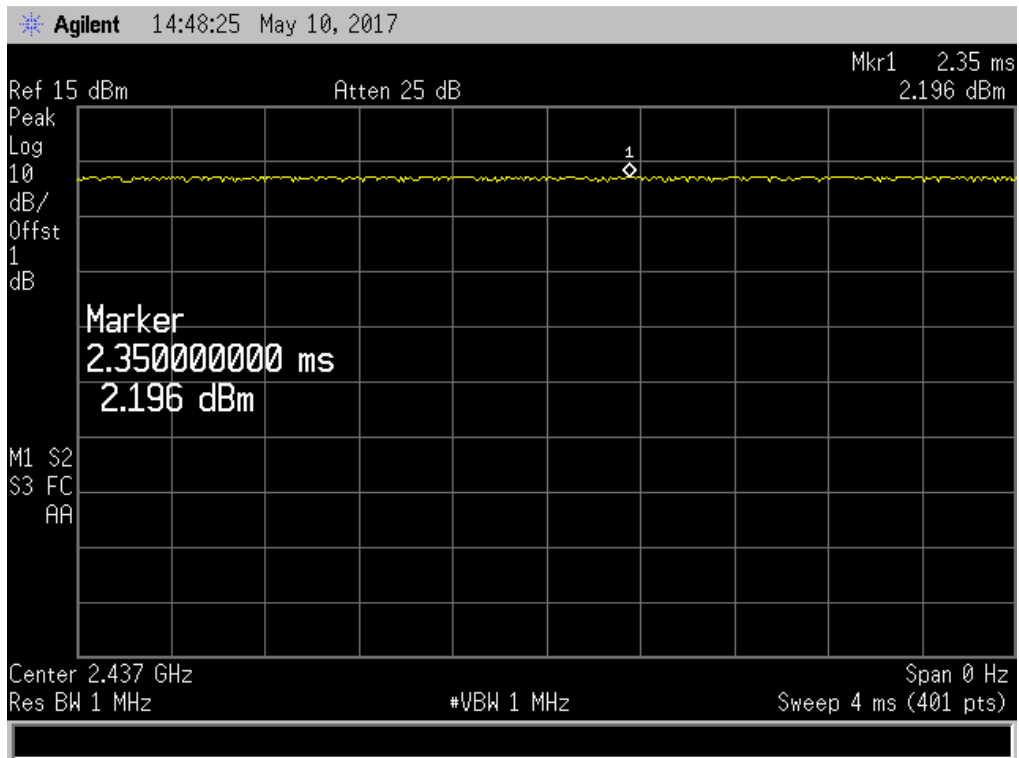

**802.11 N(HT40) Mode 2437 MHz**

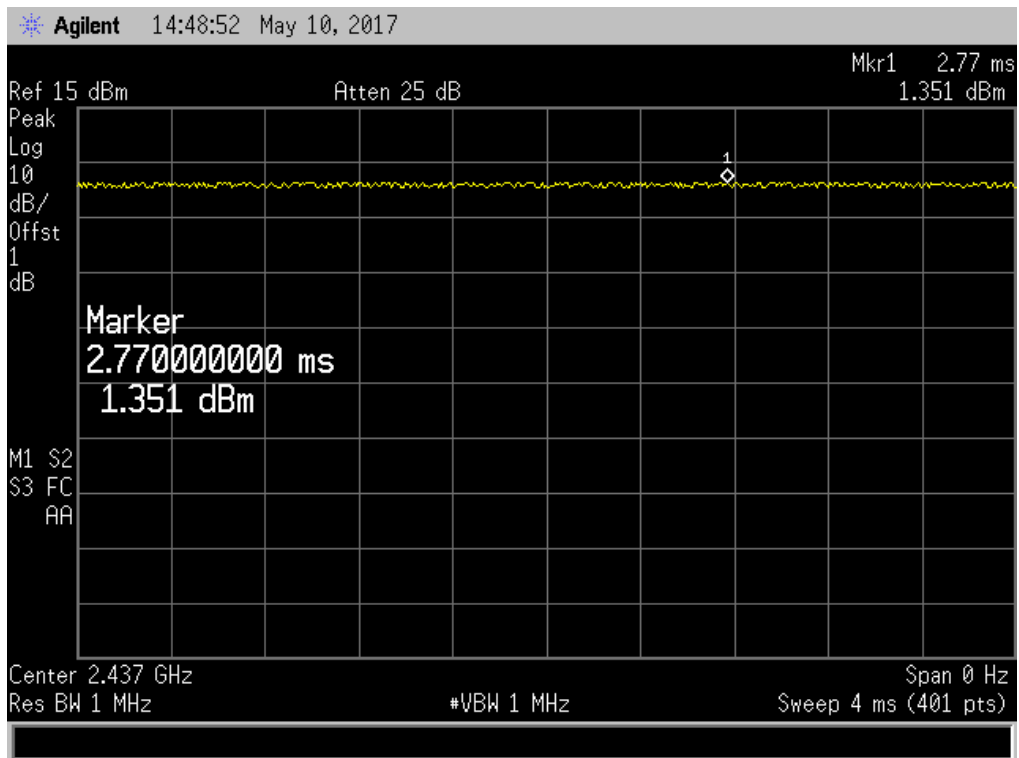

## 9. Power Spectral Density Test

### 9.1 Test Standard and Limit

#### 9.1.1 Test Standard

FCC Part 15.247 (e)

#### 9.1.2 Test Limit

FCC Part 15 Subpart C(15.247)		
Test Item	Limit	Frequency Range(MHz)
Power Spectral Density	8dBm(in any 3 kHz)	2400~2483.5

### 9.2 Test Setup

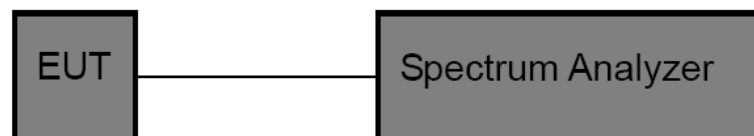

### 9.3 Test Procedure

The EUT was directly connected to the Spectrum Analyzer and antenna output port as show in the block diagram above. The measurement according to section 10.2 of KDB 558074 D01 DTS Meas Guidance v04.

- (1) The EUT was directly connected to the spectrum analyzer and antenna output port as show in the block diagram above.
- (2) Set analyser center frequency to DTS channel center frequency.
- (3) Set the span to 1.5 times the DTS bandwidth.
- (4) Set the RBW to: 3 kHz
- (5) Set the VBW to: 10 kHz
- (6) Detector: peak
- (7) Sweep time: auto
- (8) Allow trace to fully stabilize. Then use the peak marker function to determine the maximum amplitude level.

### 9.4 EUT Operating Condition

The EUT was set to continuously transmitting in each mode and low, Digital photo framesdle and high channel for the test.

9.5 Test Data

<b>EUT:</b>	Smart Clock Camera	<b>Model:</b>	GF-H100base
<b>Temperature:</b>	25 °C	<b>Relative Humidity:</b>	55%
<b>Test Voltage:</b>	DC 3.6V		
<b>Test Mode:</b>	TX 802.11B Mode		
<b>Channel Frequency (MHz)</b>	<b>Power Density (3 kHz/dBm)</b>	<b>Limit (dBm)</b>	
2412	-16.01	<b>8</b>	
2437	-16.73		
2462	-13.88		

**802.11B Mode**

**2412 MHz**

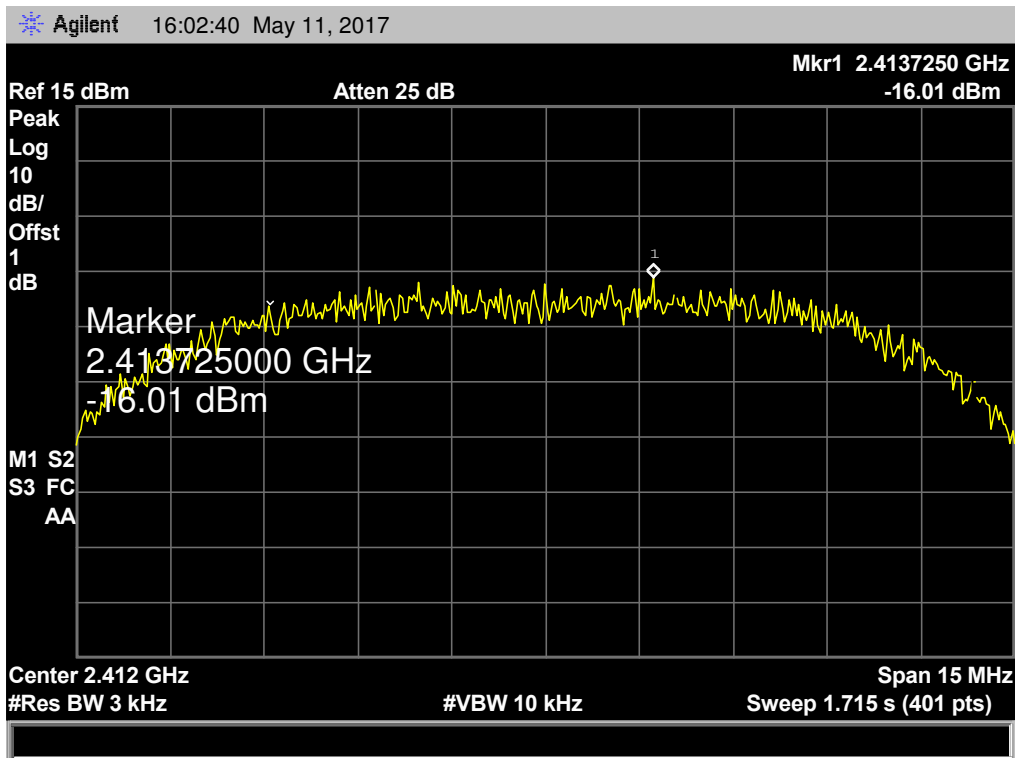

**802.11B Mode**

**2437 MHz**

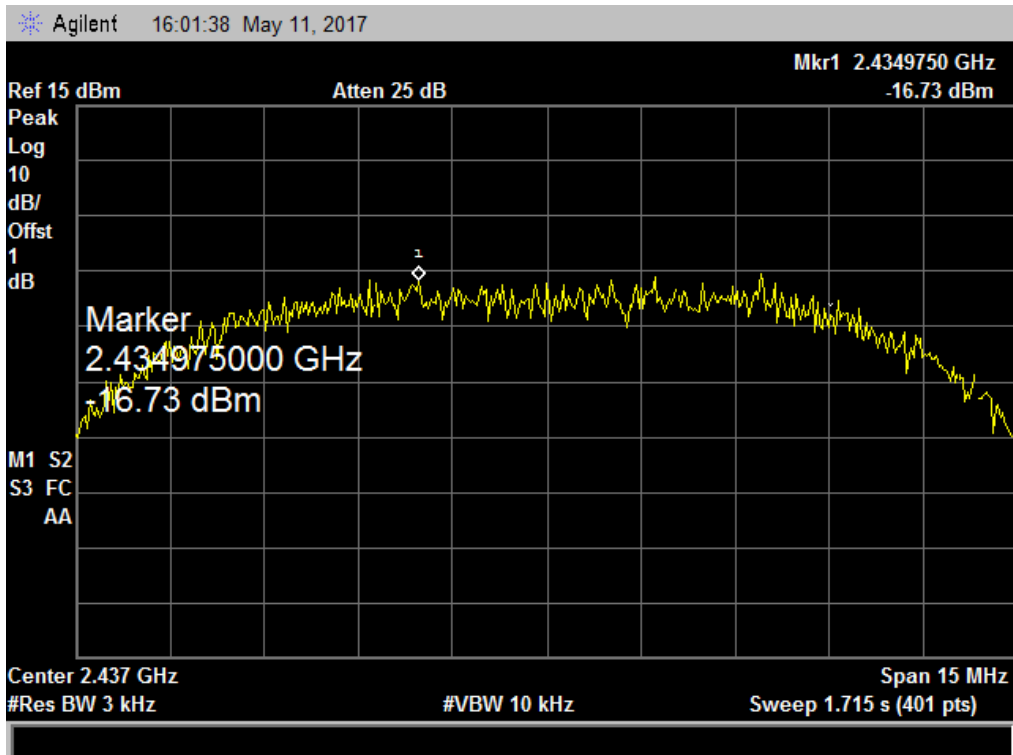

**802.11B Mode**

**2462 MHz**

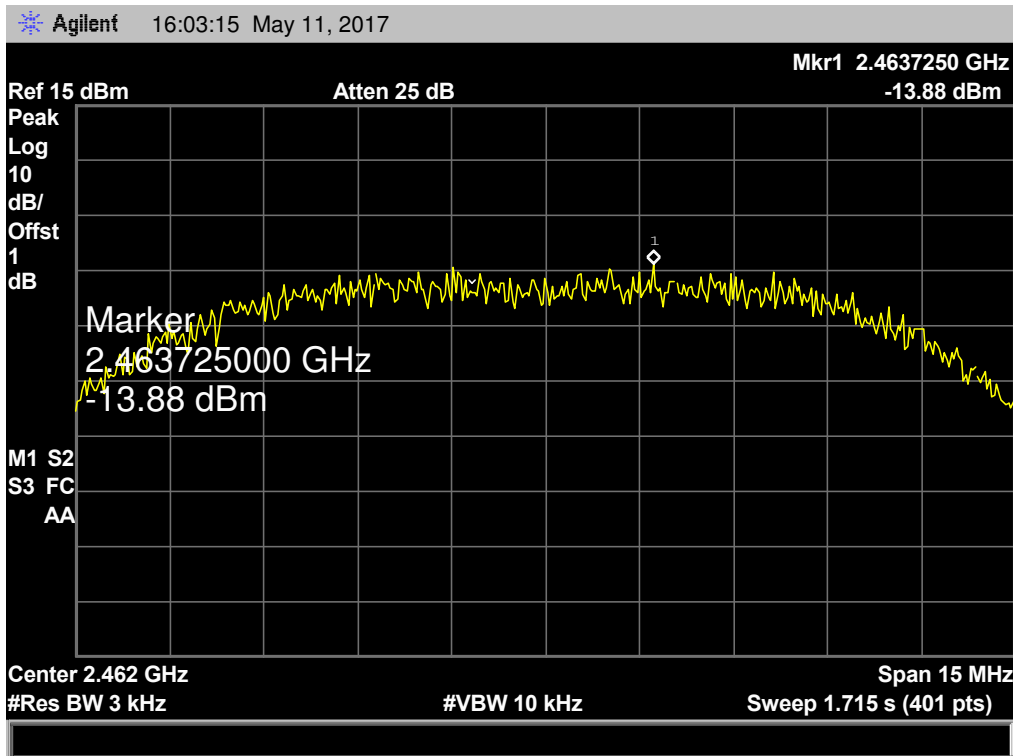

<b>EUT:</b>	Smart Clock Camera	<b>Model:</b>	GF-H100base
<b>Temperature:</b>	25 °C	<b>Temperature:</b>	25 °C
<b>Test Voltage:</b>	DC 3.6V		
<b>Test Mode:</b>	TX 802.11G Mode		
<b>Channel Frequency (MHz)</b>	<b>Power Density (3 kHz/dBm)</b>	<b>Limit (dBm)</b>	
2412	-16.33	<b>8</b>	
2437	-15.99		
2462	-16.01		
<b>802.11G Mode</b>			
<b>2412 MHz</b>			

Agilent 16:08:03 May 11, 2017

Ref 15 dBm      Atten 25 dB      Mkr1 2.41200 GHz  
 Peak      -16.33 dBm  
 Log  
 10  
 dB/  
 Offst  
 1  
 dB

Marker  
 2.41200000 GHz  
 -16.33 dBm

M1 S2  
 S3 FC  
 AA

Center 2.412 GHz      Span 25.5 MHz  
 #Res BW 3 kHz      #VBW 10 kHz      Sweep 2.916 s (401 pts)

**802.11G Mode**

**2437 MHz**

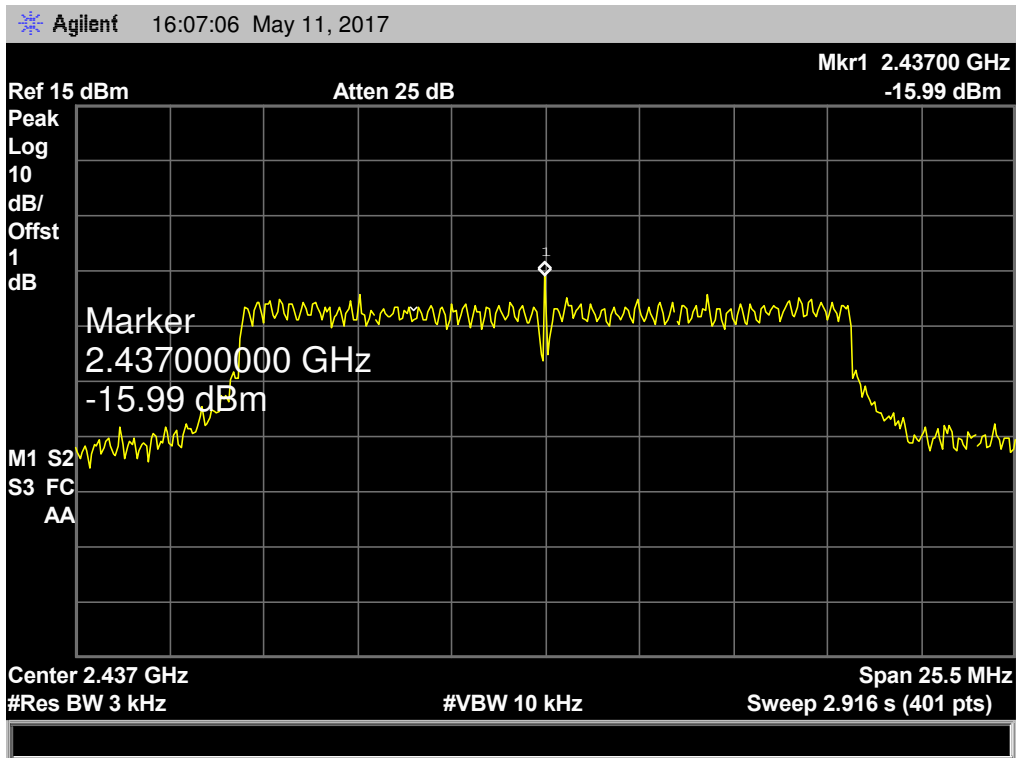

**802.11G Mode**

**2462 MHz**

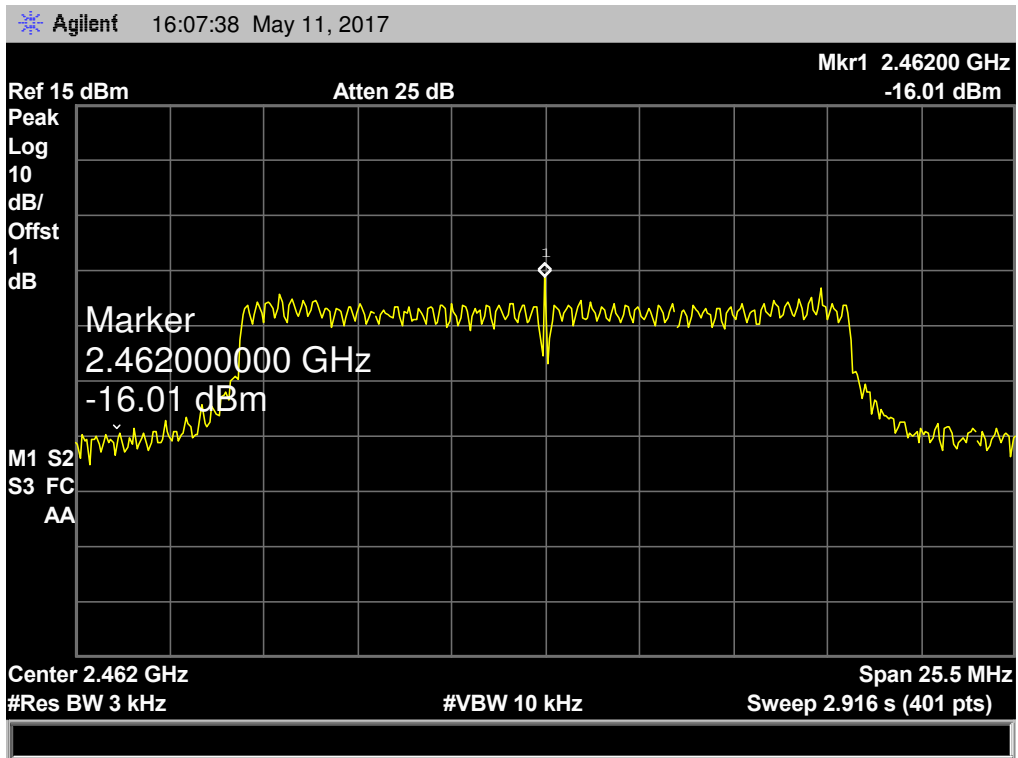

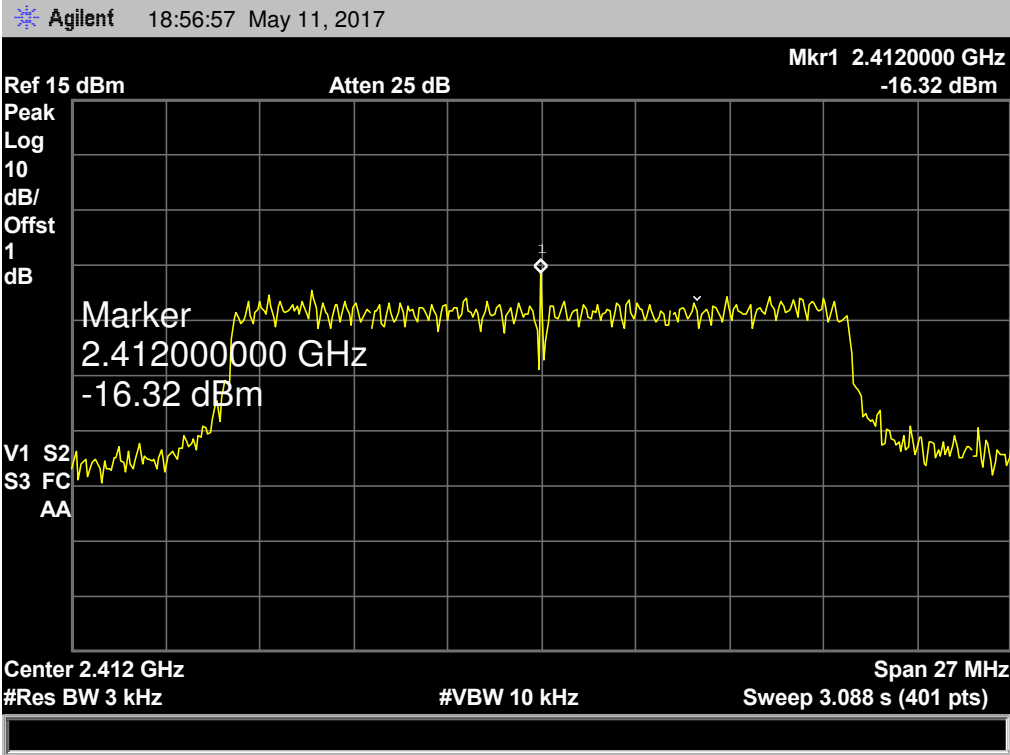
<b>EUT:</b>	Smart Clock Camera	<b>Model:</b>	GF-H100base
<b>Temperature:</b>	25 °C	<b>Temperature:</b>	25 °C
<b>Test Voltage:</b>	DC 3.6V		
<b>Test Mode:</b>	TX 802.11N(HT20) Mode		
<b>Channel Frequency (MHz)</b>	<b>Power Density (3 kHz/dBm)</b>	<b>Limit (dBm)</b>	
2412	-16.32	<b>8</b>	
2437	-19.31		
2462	-19.06		
<b>802.11N(HT20) Mode</b>			
<b>2412 MHz</b>			
			

**802.11N(HT20) Mode**

**2437 MHz**

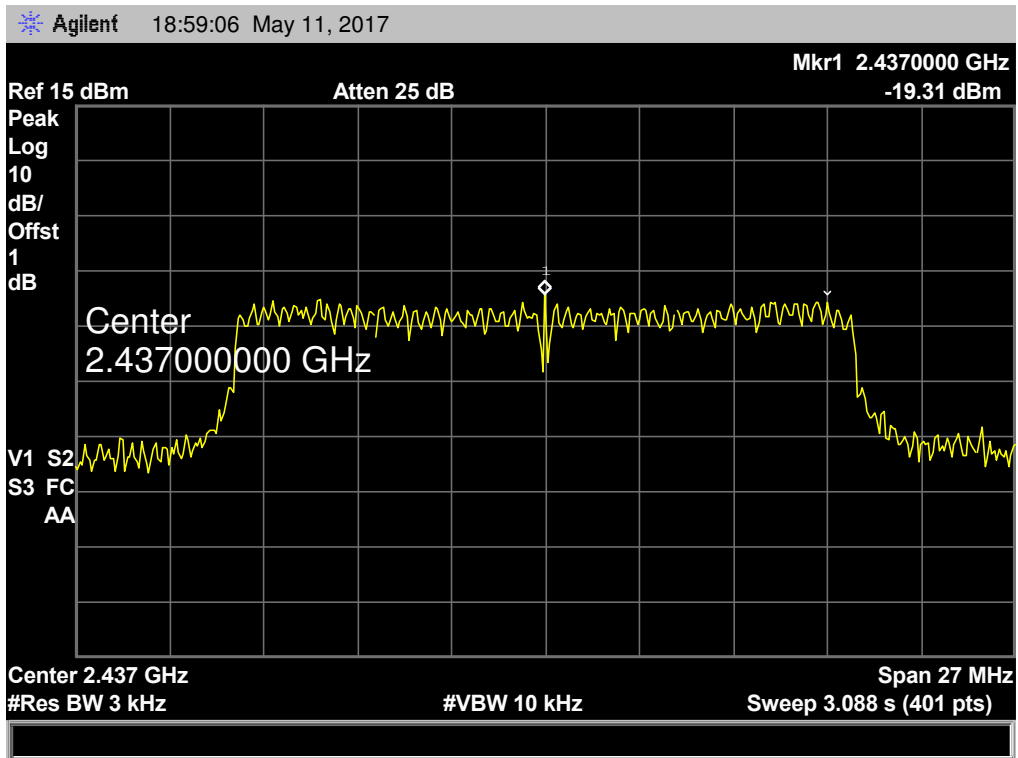

**802.11N(HT20) Mode**

**2462 MHz**

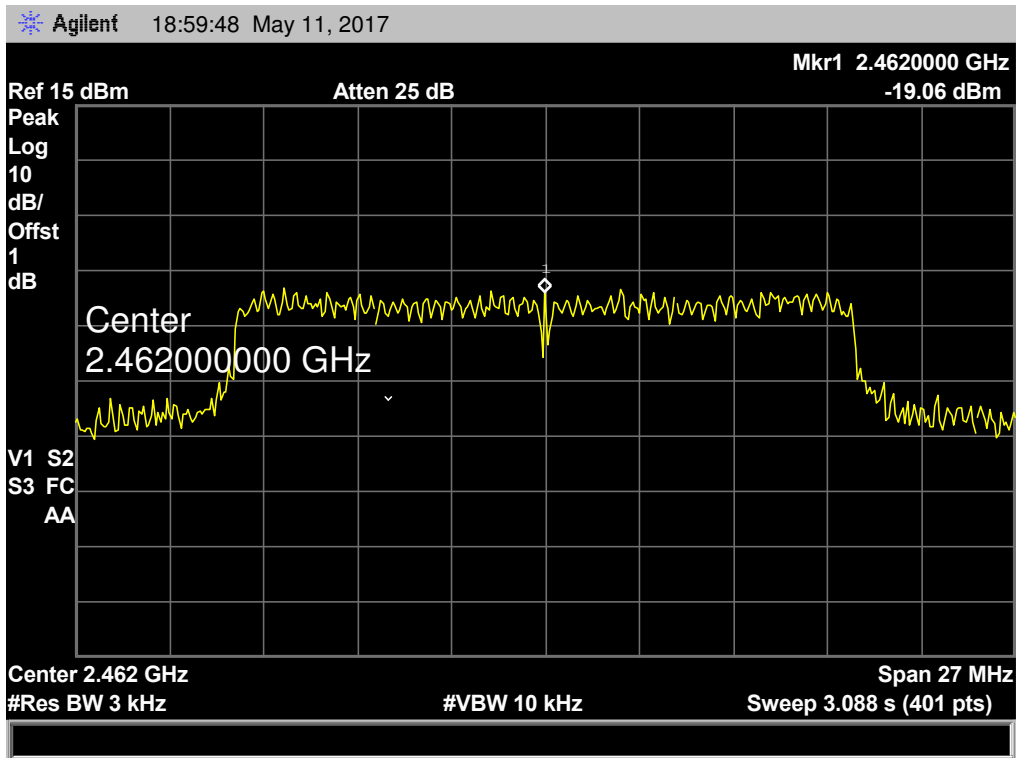

<b>EUT:</b>	Smart Clock Camera	<b>Model:</b>	GF-H100base
<b>Temperature:</b>	25 °C	<b>Temperature:</b>	25 °C
<b>Test Voltage:</b>	DC 3.6V		
<b>Test Mode:</b>	TX 802.11N(HT40) Mode		
Channel Frequency (MHz)	Power Density (3 kHz/dBm)	Limit (dBm)	
2422	-22.11	8	
2437	-22.35		
2452	-22.18		
<b>802.11N(HT40) Mode</b>			
<b>2422 MHz</b>			
<p>Agilent 19:17:13 May 11, 2017</p> <p>Ref 15 dBm Atten 25 dB Mkr1 2.422000 GHz -22.11 dBm</p> <p>Peak Log 10 dB/Offst 1 dB</p> <p>Marker 2.422000000 GHz -22.11 dBm</p> <p>M1 S2 S3 FC AA</p> <p>Center 2.422 GHz Span 54 MHz</p> <p>#Res BW 3 kHz #VBW 10 kHz Sweep 6.176 s (401 pts)</p>			

**802.11N(HT40) Mode**

**2437 MHz**

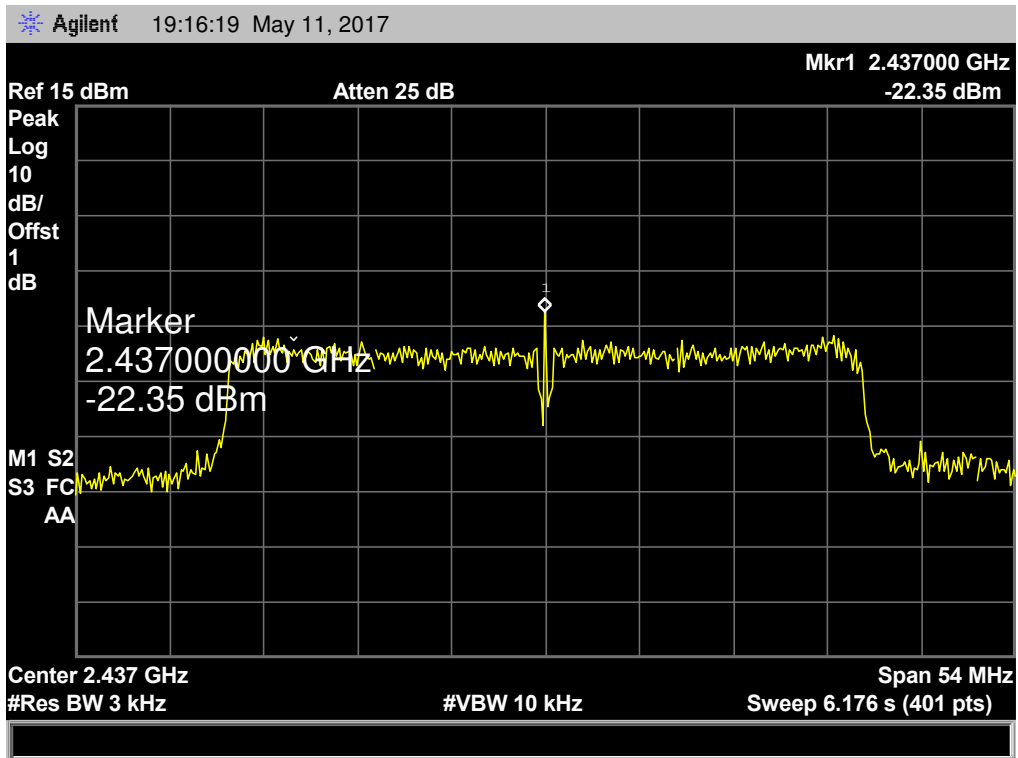

**802.11N(HT40) Mode**

**2452 MHz**

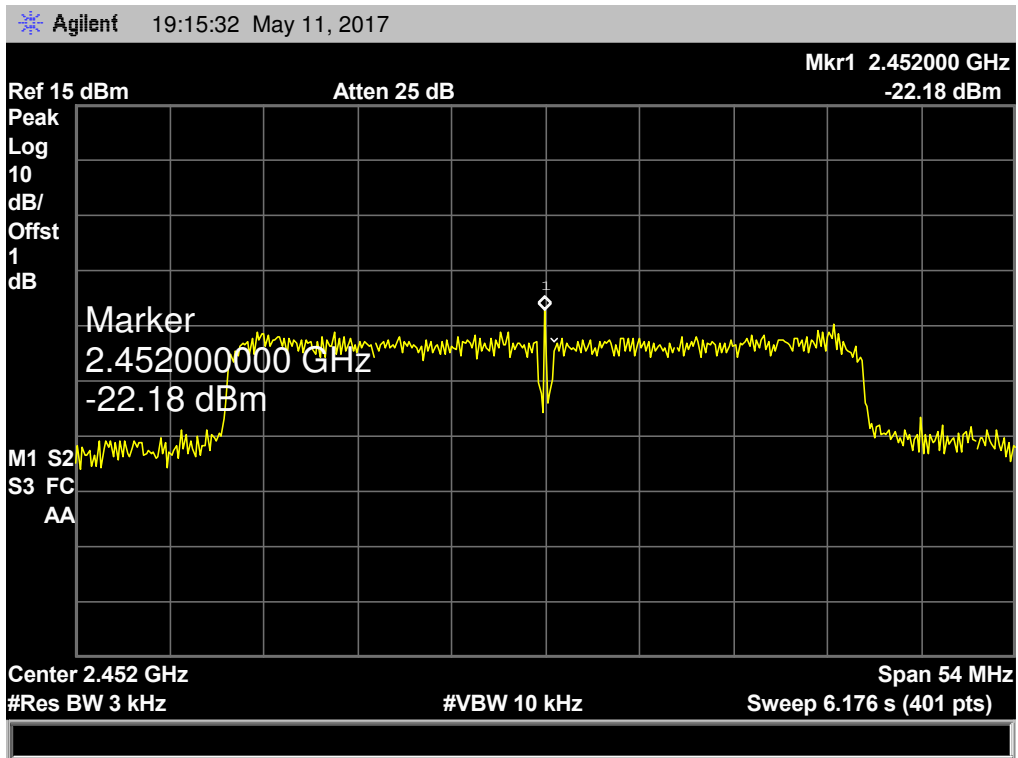

## 10. Antenna Requirement

### 10.1 Standard Requirement

#### 10.1.1 Standard

FCC Part 15.203

#### 10.1.2 Requirement

An intentional radiator shall be designed to ensure that no antenna other than that furnished by the responsible party shall be used with the device. The use of a permanently attached antenna or of an antenna that uses a unique coupling to the intentional radiator shall be considered sufficient to comply with the provisions of this Section. The manufacturer may design the unit so that a broken antenna can be replaced by the user, but the use of a standard antenna jack or electrical connector is prohibited.

### 10.2 Antenna Connected Construction

The directional gains of the antenna used for transmitting is 2 dBi, and the antenna de-signed with permanent attachment and no consideration of replacement. Please see the EUT photo for details.

#### Result

The EUT antenna is a Integral Antenna. It complies with the standard requirement.

Antenna Type
<input type="checkbox"/> Permanent attached antenna
<input checked="" type="checkbox"/> Unique connector antenna
<input type="checkbox"/> Professional installation antenna

-----END OF REPORT-----