

XT-ZB6

—Zigbee3.0 and BLE5.0 Coexistence Module

Product Specification

Version: 1.0

Date: June.23, 2022

Features

■ General

- Chip: BL706C-22
- Optional: 16M bit Flash, 16M bit pSRAM
- Module Size: 16mm x 24mm x 3mm
- Bluetooth® Specification v5.0
- Zigbee 3.0, Base Device Behavior, Core Stack R21, Green Power
- 2.4 GHz RF transceiver
- Support BLE/Zigbee coexistence

■ Standards Supported

- IEEE 802.15.4 MAC/PHY
- Bluetooth® Low Energy 1Mbps and 2Mbps
- Bluetooth® Long Range Coded 500Kbps and 125Kbps
- Integrated balun, PA/LNA

■ MCU Features

- 32-bit RISC CPU with FPU
- One RTC timer update to one year
- CPU frequency configurable from 1MHz to 144MHz
- JTAG development support
- XIP QSPI Flash/pSRAM with hardware encryption support
- 132KB RAM
- 192KB ROM
- 1Kb eFuse

■ Peripheral Interfaces

- USB2.0 Full-Speed interface
- GPIO * 31;
- UART * 2;
- IIC * 1;
- IIS * 1

- Ethernet RMII interface
- Camera interface
- SPI * 1;
- EN * 1;
- PWM *5;
- 10-bit DAC ;
- 12-bit ADC;
- PIR * 1;
- IR remote control interface

■ Working temperature: -40°C-85°C

Applications

- Serial transparent transmission;
- Smart power plug/Smart LED light;
- Sensor networks;
- Industrial wireless control;

Module Type

Name	Antenna Type
XT-ZB6	PCB ANT
XT-ZB6-E	IPEX V1

Module Structure

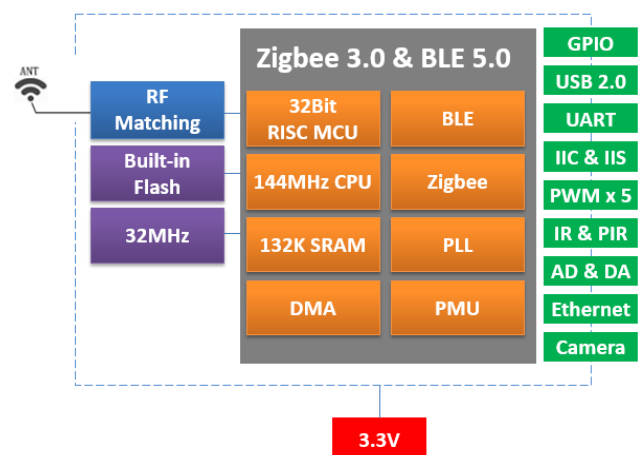

Update Record

Date	Version	Update
2022-06-23	V1.0	First released

廣東通智數

Table of Contents

1. Introduction	1
2. Interface Definition	3
3. Size and Layout.....	5
4. Electrical Characteristics.....	6
5. Power Consumption	7
6. RF Characteristics	7
7. Recommended Reflow Profile.....	8
8. Minimum User System.....	8
9. Recommended Layout Design	9
10. Peripheral Design Suggestion	10
11. Product Handling.....	10
12. U.F.L RF Connector.....	11
13. Packing Instruction.....	11

1. Introduction

XT-ZB6 is highly integrated BLE and Zigbee combo module for IoT applications.

XT-ZB6's wireless subsystem contains 2.4G radio, BLE + Zigbee baseband and MAC designs. Microcontroller subsystem contains 32-bit RISC CPU, high-speed cache and memories. Power Management Unit controls ultra-low-power modes. Moreover, varieties of security features are supported.

Peripheral interfaces include UART, PWM, USB, I2C, ADC, DAC and GPIOs.

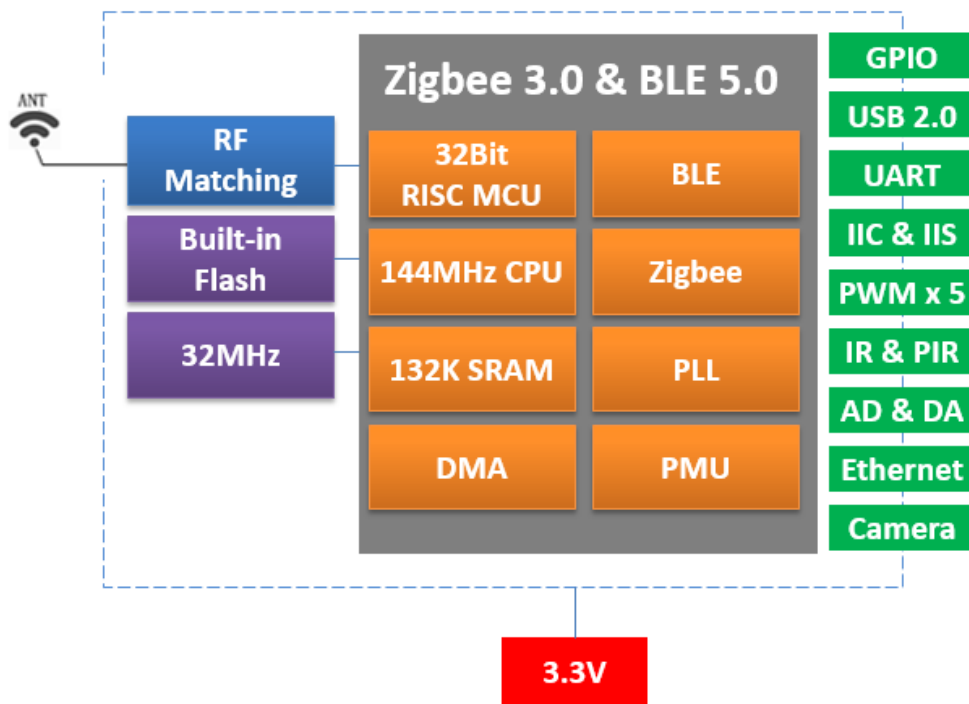

Fig.1.1 XT-ZB6 Module Structure

Technical parameters for XT-ZB6 are listed as follows.

Table 1.1 XT-ZB6 Parameters

Types	Items	Parameters
RF	Zigbee Sensitivity	-104 dBm @250Kbps
	BLE Sensitivity	-104 dBm @120Kbps
		-100 dBm @500Kbps
		-97 dBm @1Mbps
		-94 dBm @2Mbps
	TX Power	0-14 dBm
	TX EVM	11%
Antenna	PCB antenna / U.F.L IPEX V1	
Hardware	CPU	32-bit RISC CPU
	Interface	UART/GPIO/PWM
	Working voltage	2.5V ~ 3.6V
	Working current	3.5mA @RF only
		17mA @TX 10dBm
		45mA @TX 14dBm
	Working temperature	-40°C ~85°C
	Storage temperature	-45°C ~ 135°C
Shape	16mm x 24mm x 3mm	
Software	Encryption type	AES 128/192/256
	Update firmware	UART Download
	Software develop	SDK

2. Interface Definition

XT-ZB6 module interface definition is shown as below.

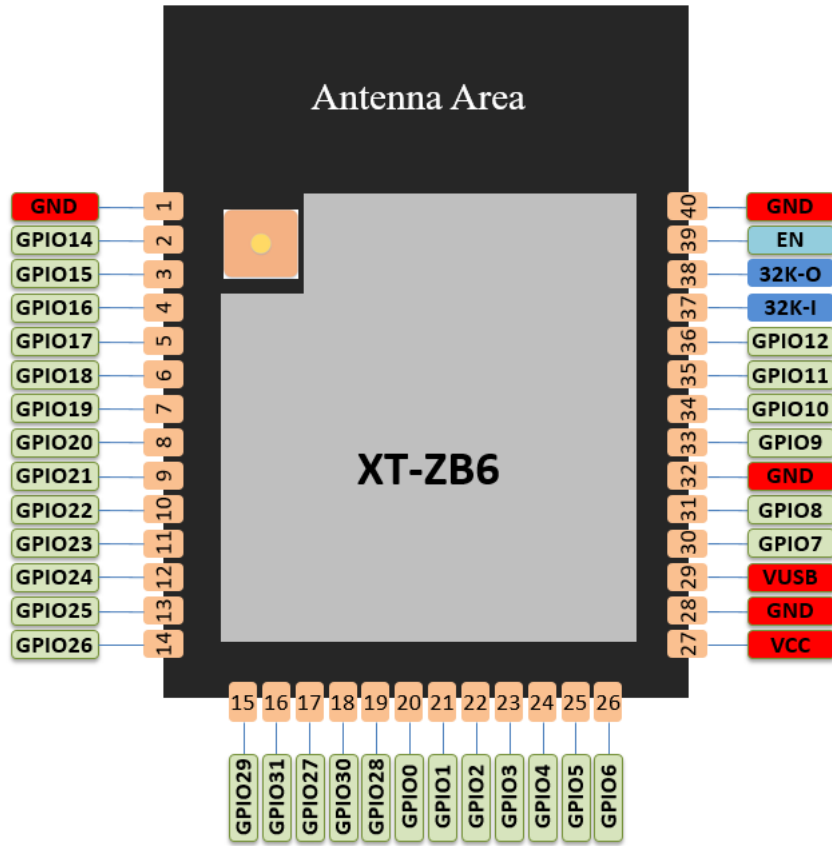

Fig.2.1 XT-ZB6 Pin Definition

Working mode and pins function are shown in Table 2.1.

Table.2.1 Working mode

Mode	GPIO31
UART Download Mode	High
Flash Boot Mode	LOW (default)

Table.2.2 Pins Function Definition

Num.	Pin Name	Type	Function
1,28. 32,40	GND	P	POWER GROUND
2	GPIO14	I/O	TXD (download),SS,SCL,ADC_CH5,I2S_DIO,PWM_CH4
3	GPIO15	I/O	RXD(download), SCLK,SDA,ADC_CH1,I2S_DIO,PWM_CH0
4	GPIO16	I/O	MOSI,SCL,PWM_CH1
5	GPIO17	I/O	MISO/MOSI,SDA,I2S_FS,PWM_CH2,DAC,PIX_DAT4
6	GPIO18	I/O	SF1_IO1,SS,PIX_DAT5,RMII_MDC
7	GPIO19	I/O	SF1_CS,SCLK,SDA,PIX_DAT6,RMII_MDIO

8	GPIO20	I/O	SF1_IO3,PIX_DAT7,SCL,RMII_RXERR
9	GPIO21	I/O	SF1_CLK,SDA,RMII_TX_EN
10	GPIO22	I/O	SF1_IO2,SS,PWM_CH2,RMII_RX_DV
11	GPIO23	I/O	SCLK, I2S_DI, SPI,SDA,PWM_CH3,IRTX
12	GPIO24	I/O	SF2_IO1,PIX_DAT5,SCL,RMII_MDC
13	GPIO25	I/O	MISO/MOSI,SDA,I2S_FS,PWM_CH0
14	GPIO26	I/O	SF2_IO3,SS,PIX_DAT7,RMII_RXERR
15	GPIO29	I/O	PIX_DAT5,PEM_CH4
16	GPIO28	I/O	MISO/MOSI,SCL,I2S_BCLK,PWM_CH3,RMII_RX_DV
17	GPIO27	I/O	SF2_CLK,SCLK, RMII_TX_EN
18	GPIO30	I/O	PIX_DAT6,SCL,PWM_CH0
19	GPIO31	I/O	PIX_DAT7,SDA,PWM_CH1,,PULL-DOWN
20	GPIO0	I/O	MISO/MOSI,SCL,I2S_BCLK,PWM_CH0
21	GPIO1	I/O	MISO/MOSI,SDA,I2S_FS,PWM_CH1
22	GPIO2	I/O	MISO/MOSI,SCL,I2S_DIO,PWM_CH2
23	GPIO3	I/O	PIX_DAT0,SDA
24	GPIO4	I/O	PIX_DAT1,SCL
25	GPIO5	I/O	PIX_DAT2,SDA
26	GPIO6	I/O	PIX_DAT3,SCL
27	VCC	P	POWER IN,3.3V
29	VUSB	P	USB power
30	GPIO7	I/O	USB_DP,SCLK,SDA,PWM_CH2,ADC_CH6
31	GPIO8	I/O	USB_DM, MISO/MOSI,SCL,PWM_CH3,ADC_CH0
33	GPIO9	I/O	MISO/MOSI,SDA,I2S_FS,PWM_CH4,ADC_CH7
34	GPIO10	I/O	SS,SCL,
35	GPIO11	I/O	SCLK,SDA
36	GPIO12	I/O	PIX_DAT4,SCL
37	32K-I	A	CRYSTAL:32.768K INPUT
38	32K-O	A	CRYSTAL:32.768K OUTPUT
39	EN	-	Chip enable; Built-in Pull-up

3. Size and Layout

Shape for XT-ZB6 can be shown as follows.



Fig.3.1 Shape for XT-ZB6

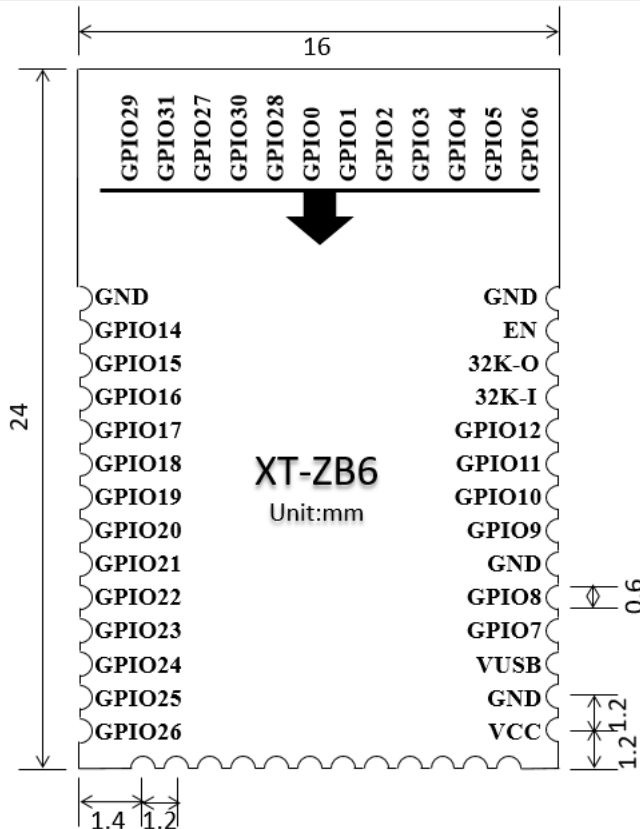

(a) Vertical View

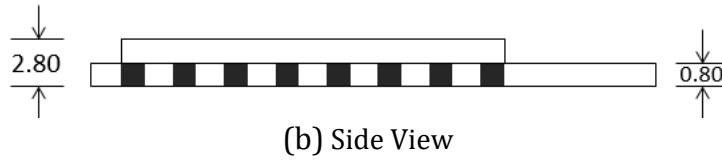

Fig.3.2 Size for XT-ZB6

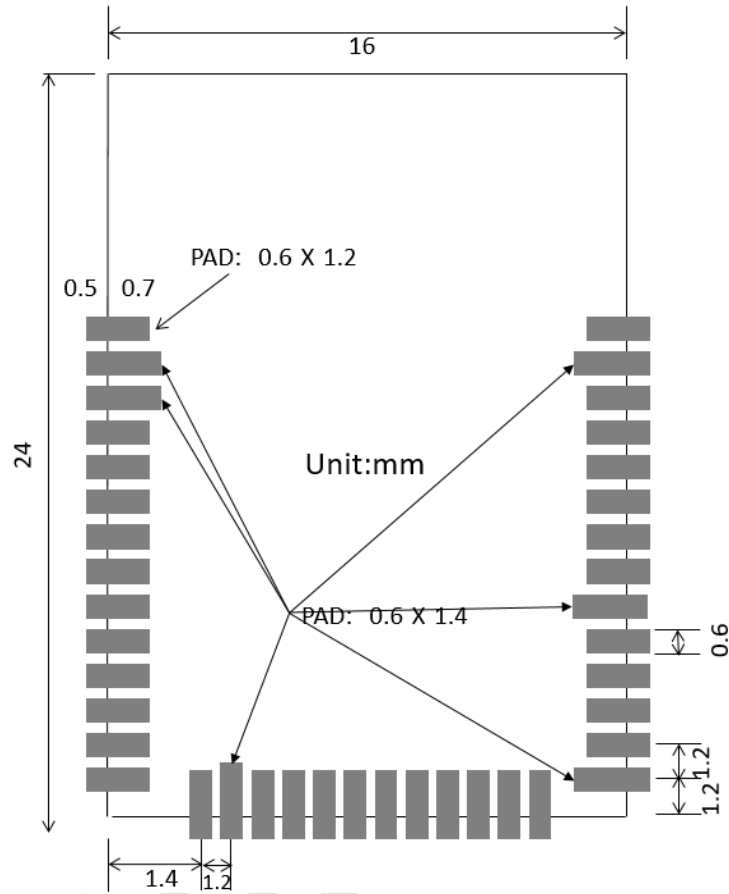

Fig.3.3 PCB Layout for XT-ZB6

4. Electrical Characteristics

Table 4.1 Electrical Characteristics

Parameters	Condition	Min	Classical	Max	Unit	
Store Temperature	-	-40	Normal	125	°C	
Sold Temperature	IPC/JEDEC J-STD-020	-	-	260	°C	
Working Voltage	-	2.5	3.3	3.6	V	
I/O	V _{IL} /V _{IH}	-	-2.0	-	0.8/-	V
	V _{OL} /V _{OH}	-	-2.4	-	0.4/-	
Electrostatic release quantity (Human model)	TAMB=25°C	-	-	2	KV	
Electrostatic release quantity (Human model)	TAMB=25°C	-	-	0.5	KV	

5. Power Consumption

Table 5.1 Power Consumption

Parameters	Min	Classical	Max	Unit
RX only	-	3.5	-	mA
TX 0dbm	-	4.8	-	mA
TX 10dbm	-	17	-	mA
TX 14dbm	-	45	-	mA
Run in RAM @RC32M 144MHz	-	8.44	-	mA
Run in RAM @RC32M 32MHz	-	3.36	-	mA
Run in FLASH @RC32M 144MHz	-	7.72	-	mA
Run in FLASH @RC32M 32MHz	-	3.39	-	mA
Hibernate Mode	-	1.2	-	uA
Shut Down	-	0.1	0	uA

6. RF Characteristics

The data in the following Table are gotten when voltage is 3.3V in the indoor temperature environment.

Table 6.1 RF Characteristics

Parameters	Min	Classical	Max	Unit
TX				
TX Power	0	0	14	dBm
TX EVM	-	11	13	%
Sensibility				
Zigbee @250Kbps	-	-104	-	dBm
BLE @125Kbps	-	-104	-	dBm
BLE @500Kbps	-	-100	-	dBm
BLE @1Mbps	-	-97	-	dBm
BLE @2Mbps	-	-94	-	dBm

7. Recommended Reflow Profile

- (1) Reflow Times ≤ 2 times (Max.)
- (2) Max Rising Slope: $3^{\circ}\text{C}/\text{sec}$
- (3) Max Falling Slope: $-3^{\circ}\text{C}/\text{sec}$
- (4) Over 217°C Time: $60\sim 120\text{sec}$
- (5) Peak Temp: $240^{\circ}\text{C}\sim 250^{\circ}\text{C}$

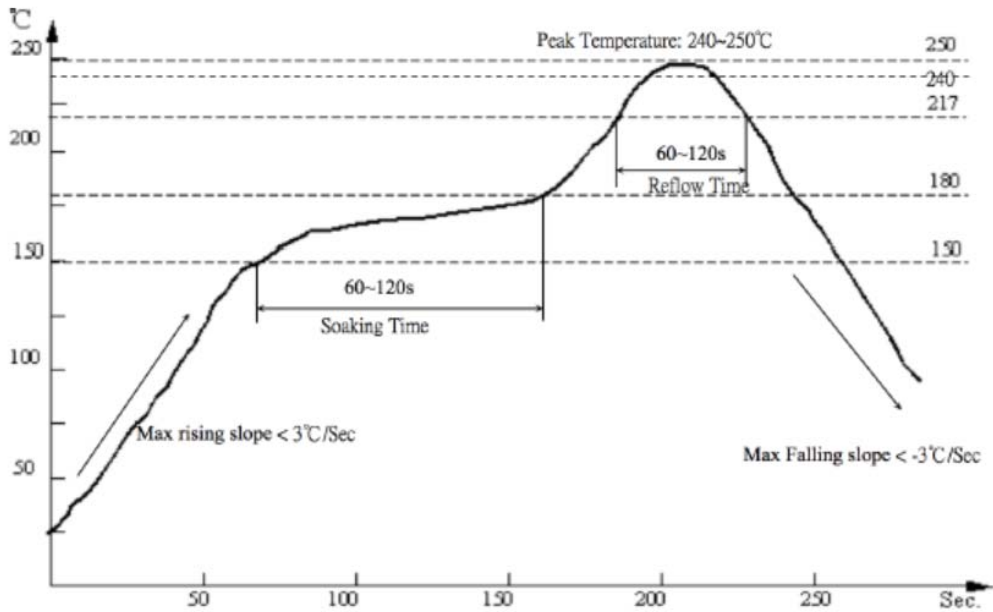

Fig.7.1 Recommended Reflow Profile

8. Minimum User System

This module can work just at 3.3V working voltage:

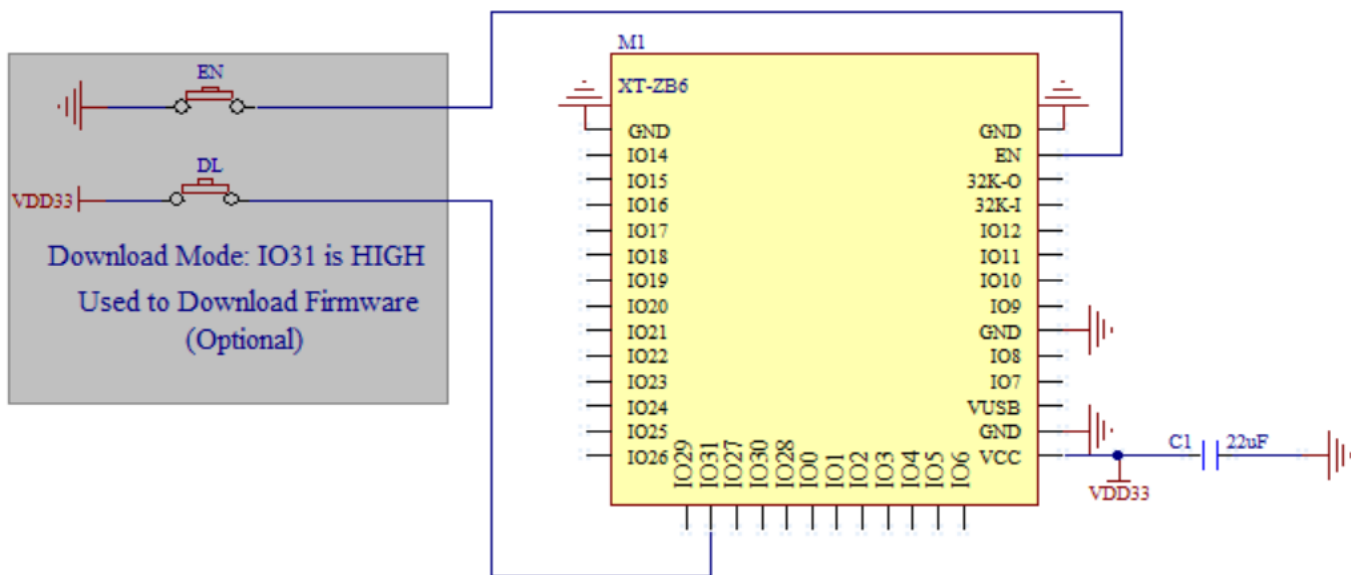

Fig.8.1 Minimum User System

Note:

- (1) The working voltage for module is DC 3.3V;
- (2) The max current from IO of this module is 12mA;
- (3) Zigbee module is at download mode: GPIO31 are HIGH level, then module reset to power on;
- (4) Zigbee module is connected to RXD of the other MCU, and TXD is connected to RXD of the other MCU.

9. Recommended Layout Design

XT-ZB6 Wi-Fi module can be sold on PCB board directly. For the high RF performance for the device, please notice the placement of the module. There are three ways to use the module for Wi-Fi Module with PCB antenna.

Solution 1: optical solution. The Wi-Fi module is placed on the side of the board, and the antennas are all exposed, and there is no metal material around the antenna, including wires, metal casings, weight plates, and the like.

Solution 2: sub-optical solution. The Wi-Fi module is placed on the side of the board, and the antenna below is hollowed out. There is a gap of not less than 5 mm reserved with the PCB, and there is no metal material around the antenna, including wires, metal casings, weight plates, and the like.

Solution 3: The Wi-Fi module is placed on the side of the board, and the PCB area under the antenna is empty, and copper cannot be laid.

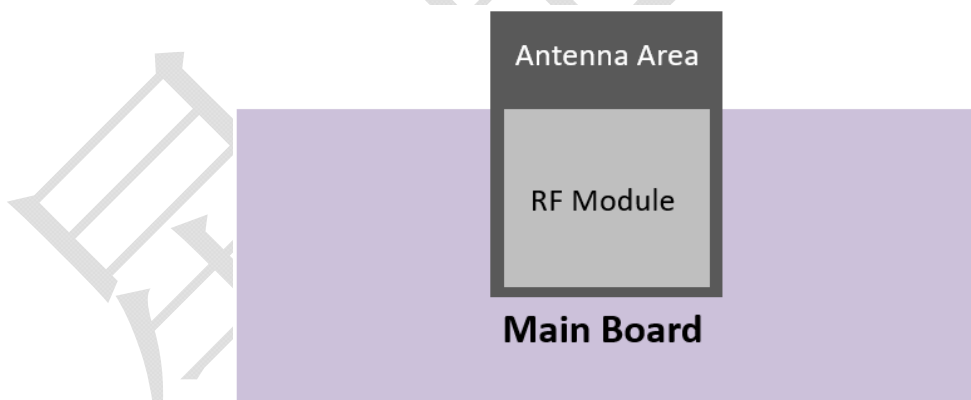

Fig.9.1 Solution 1

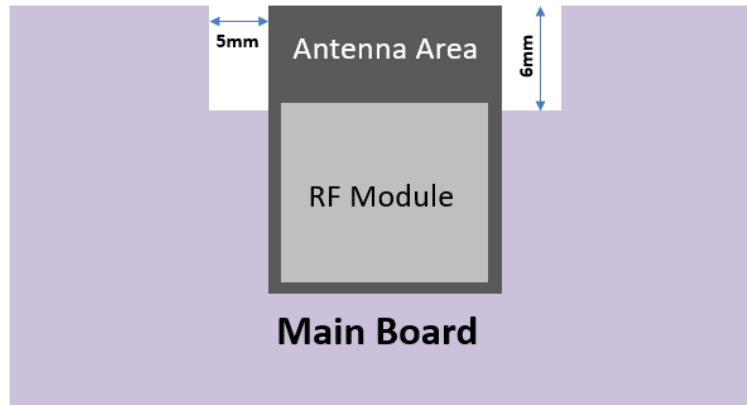

Fig.9.2 Solution 2

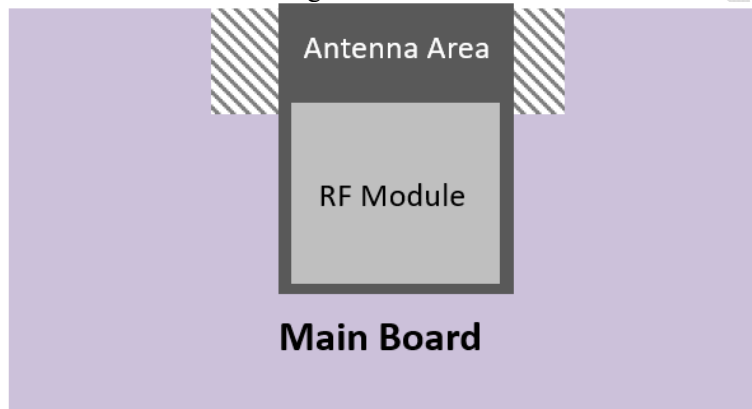

Fig.9.3 Solution 3

10. Peripheral Design Suggestion

XT-ZB6 module is already integrated into high-speed GPIO and Peripheral interface, which may be generated the switch noise. If there is a high request for the power consumption and EMI characteristics, it is suggested to connect a serial 10~100 ohm resistance, which can suppress overshoot when switching power supply, and can smooth signal. At the same time, it also can prevent electrostatic discharge (ESD).

11. Product Handling

11.1 Storage Conditions

The products sealed in moisture barrier bags (MBB) should be stored in a non-condensing atmospheric environment of $< 40\text{ }^{\circ}\text{C}$ and $/90\%\text{RH}$. The module is rated at the moisture sensitivity level (MSL) of 3. After unpacking, the module must be soldered within 168 hours with the factory conditions $25\pm 5\text{ }^{\circ}\text{C}$ and $/60\%\text{RH}$. If the above conditions are not met, the module needs to be baked.

11.2 Electrostatic Discharge (ESD)

- Human body model (HBM): $\pm 2000\text{ V}$

- Charged-device model (CDM): ± 500 V

12. U.F.L RF Connector

XT-ZB6-E module use U.F.L type RF connector for external antenna connection. (IPEX V1.0).

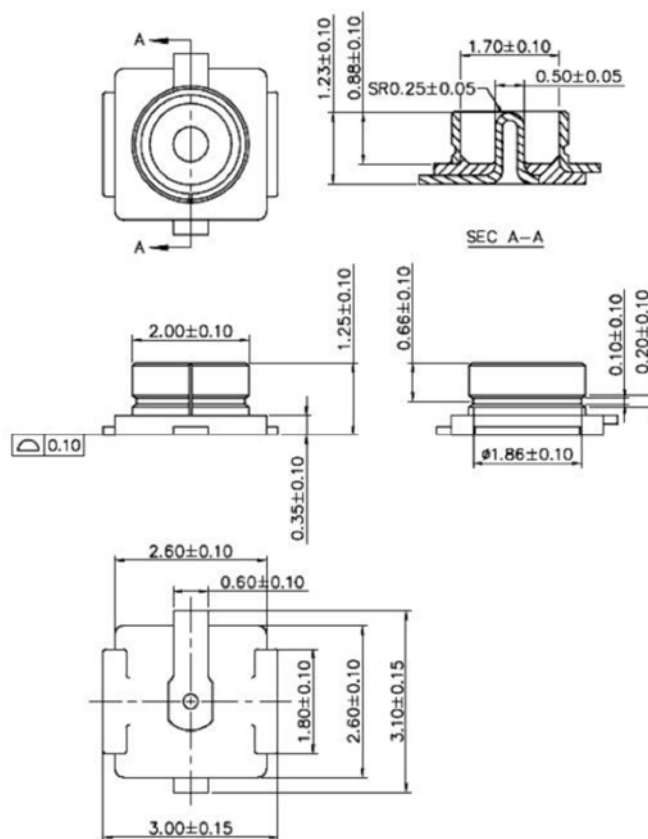

Fig.12.1 U.F.L RF Connector

13. Packing Instruction

The product is packed in a tray, as shown in the following figure.

The size of the single box is: 340 x 360 x 60mm, and 800 pieces module is in the box. And the outer box size is 355 x 375 x 325mm, including 5 single box which include 4000 pieces module.



Fig.13.1 Module Package

FCC WARNING

FCC Caution: Any changes or modifications not expressly

Approved by the party responsible for compliance could void the user's authority to operate this equipment.

This device complies with Part 15 of the FCC Rules.

Operation is subject to the following two conditions: (1) This device may not cause harmful interference, and (2) this device must accept any interference received, including interference that may cause undesired operation.

This device and its antenna(s) must not be co-located or operating in conjunction with any other antenna or transmitter.

15.105 Information to the user.

(b) For a Class B digital device or peripheral, the instructions furnished the user shall include the following or similar statement, placed in a prominent location in the text of the manual:

Note: This equipment has been tested and found to comply with the limits for a Class B digital device, pursuant to part 15 of the FCC Rules. These limits are designed to provide reasonable protection against harmful interference in a residential installation. This equipment generates, uses and can radiate radio frequency energy and, if not installed and used in accordance with the instructions, may cause harmful interference to radio communications. However, there is no guarantee that interference will not occur in a particular installation. If this equipment does cause harmful interference to radio or television reception, which can be determined by turning the equipment off and on, the user is encouraged to try to correct the interference by one or more of the following measures:

- Reorient or relocate the receiving antenna.
- Increase the separation between the equipment and receiver.
- Connect the equipment into an outlet on a circuit different from that to which the receiver is connected.
- Consult the dealer or an experienced radio/TV technician for help.

This equipment complies with FCC radiation exposure limits set forth for an uncontrolled environment. This equipment should be installed and operated with minimum distance 20 cm between the radiator and your body. Radiation Exposure Statement:

This equipment complies with FCC radiation exposure limits set forth for an uncontrolled environment.

This transmitter must not be co-located or operating in conjunction with any other antenna or transmitter.

The availability of some specific channels and/or operational frequency bands are country dependent and are firmware programmed at the factory to match the intended destination. The firmware setting is not accessible by the end user.

The final end product must be labelled in a visible area with the following:

“Contains Transmitter Module “2AL3B-XT-ZB6”

Requirement per KDB996369 D03

2.2 List of applicable FCC rules

List the FCC rules that are applicable to the modular transmitter. These are the rules that specifically establish the bands of operation, the power, spurious emissions, and operating fundamental frequencies. DO NOT list compliance to unintentional-radiator rules (Part 15 Subpart B) since that is not a condition of a module grant that is extended to a host manufacturer. See also Section

2.10 below concerning the need to notify host manufacturers that further testing is required.³

Explanation: This module meets the requirements of FCC part 15C (15.247).it Specifically identified AC Power Line Conducted Emission, Radiated Spurious emissions, Band edge and RF Conducted Spurious Emissions, Conducted Peak Output Power, Bandwidth, Power Spectral Density, Antenna Requirement.

2.3 Summarize the specific operational use conditions

Describe use conditions that are applicable to the modular transmitter, including for example any limits on antennas, etc. For example, if point-to-point antennas are used that require reduction in power or compensation for cable loss, then this information must be in the instructions. If the use condition limitations extend to professional users, then instructions must state that this information also extends to the host manufacturer's instruction manual. In addition, certain information may also be needed, such as peak gain per frequency band and minimum gain, specifically for master devices in 5 GHz DFS bands.

Explanation: The product antenna uses an irreplaceable antenna with a gain of 1dBi

2.4 Single Modular

If a modular transmitter is approved as a "Single Module," then the module manufacturer is responsible for approving the host environment that the Single Modular is used with. The manufacturer of a Single Modular must describe, both in the filing and in the installation instructions, the alternative means that the Single Modular manufacturer uses to verify that the host meets the necessary requirements to satisfy the module limiting conditions.

A Single Modular manufacturer has the flexibility to define its alternative method to address the conditions that limit the initial approval, such as: shielding, minimum signaling amplitude, buffered modulation/data inputs, or power supply regulation. The alternative method could include that the limited module manufacturer reviews detailed test data or host designs prior to giving the host manufacturer approval.

This Single Modular procedure is also applicable for RF exposure evaluation when it is necessary to demonstrate compliance in a specific host. The module manufacturer must state how control of the product into which the modular transmitter will be installed will be maintained such that full compliance of the product is always ensured. For additional hosts other than the specific host originally granted with a limited module, a Class II permissive change is required on the module grant to register the additional host as a specific host also approved with the module. Explanation: The module is a single module.

2.5 Trace antenna designs

For a modular transmitter with trace antenna designs, see the guidance in Question 11 of

KDB Publication 996369 D02 FAQ – Modules for Micro-Strip Antennas and traces. The integration information shall include for the TCB review the integration instructions for the following aspects: layout of trace design, parts list (BOM), antenna, connectors, and isolation requirements.

a) Information that includes permitted variances (e.g., trace boundary limits, thickness, length, width, shape(s), dielectric constant, and impedance as applicable for each type of antenna); b) Each design shall be considered a different type (e.g., antenna length in multiple(s) of frequency, the wavelength, and antenna shape (traces in phase) can affect antenna gain and must be considered); c) The parameters shall be provided in a manner permitting host manufacturers to design the printed circuit (PC) board layout; d) Appropriate parts by manufacturer and specifications; e) Test procedures for design verification; and f) Production test procedures for ensuring compliance

The module grantee shall provide a notice that any deviation(s) from the defined parameters of the antenna trace, as described by the instructions, require that the host product manufacturer must notify the module grantee that they wish to change the antenna trace design. In this case, a Class II permissive change application is required to be filed by the grantee, or the host manufacturer can take responsibility through the change in FCC ID (new application) procedure followed by a Class II permissive change application

2.6 RF exposure considerations

It is essential for module grantees to clearly and explicitly state the RF exposure conditions that permit a host product manufacturer to use the module. Two types of instructions are required for RF exposure information: (1) to the host product manufacturer, to define the application conditions

(Mobile, portable – xx cm from a person's body); and (2) additional text needed for the host product manufacturer to provide to end users in their end-product manuals. If RF exposure statements and use conditions are not provided, then the host product manufacturer is required to take responsibility of the module through a change in FCC ID (new application). Explanation: The module complies with FCC radiofrequency radiation exposure limits for uncontrolled environments. The device is installed and operated with a distance of more than 20 cm between the radiator and your body." This module follows FCC statement design, FCC ID: 2AL3B-XT-ZB6

2.7 Antennas

A list of antennas included in the application for certification must be provided in the instructions. For modular transmitters approved as limited modules, all applicable professional installer instructions must be included as part of the information to the host product manufacturer. The antenna list shall also identify the antenna types (monopole, PIFA, dipole, etc. (note that for example an "omni-directional antenna" is not considered to be a specific "antenna type").

For situations where the host product manufacturer is responsible for an external connector, for example with an RF pin and antenna trace design, the integration instructions shall inform the installer that unique antenna connector must be used on the Part 15 authorized transmitters used in the host product.

The module manufacturers shall provide a list of acceptable unique connectors.

Explanation: The product antenna uses an irreplaceable antenna with a gain of 1dBi

2.8 Label and compliance information

Grantees are responsible for the continued compliance of their modules to the FCC rules. This includes advising host product manufacturers that they need to provide a physical or e-label stating "Contains FCC ID" with their finished product. See Guidelines for Labeling and User Information for RF Devices – KDB Publication 784748.

Explanation: The host system using this module, should have label in a visible area indicated the following texts: "Contains FCC ID: 2AL3B-XT-ZB6

2.9 Information on test modes and additional testing requirements

5 Additional guidance for testing host products is given in KDB Publication 996369 D04 Module Integration Guide. Test modes should take into consideration different operational conditions for a stand-alone modular transmitter in a host, as well as for multiple simultaneously transmitting modules or other transmitters in a host product.

The grantee should provide information on how to configure test modes for host product evaluation for different operational conditions for a stand-alone modular transmitter in a host, versus with multiple, simultaneously transmitting modules or other transmitters in a host.

Grantees can increase the utility of their modular transmitters by providing special means, modes, or instructions that simulates or characterizes a connection by enabling a transmitter. This can greatly simplify a host manufacturer's determination that a module as installed in a host complies with FCC requirements.

Explanation: Hinged ling yang Electronic Technology Co., Ltd. can increase the utility of our modular transmitters by providing instructions that simulates or characterizes a connection by enabling a transmitter.

2.10 Additional testing, Part 15 Subpart B disclaimer

The grantee should include a statement that the modular transmitter is only FCC authorized for the specific rule parts (i.e., FCC transmitter rules) listed on the grant, and that the host product manufacturer is responsible for compliance to any other FCC rules that apply to the host not covered by the modular transmitter grant of certification. If the grantee markets their product as being Part 15

Subpart B compliant (when it also contains unintentional-radiator digital circuitry), then the grantee shall provide a notice stating that the final host product still requires Part 15 Subpart B compliance testing with the modular transmitter installed.

Explanation: The module without unintentional-radiator digital circuitry, so the module does not require an evaluation by FCC Part 15 Subpart B. The host should be evaluated by the FCC Subpart B.