

Note: The 8-DPSK (3DH5) modulation is the worst case and recorded in the report.

3.6. Dwell Time

Limit

Section	Test Item	Limit
15.247(a)(1)	Average Time of Occupancy	0.4 sec

Test Configuration

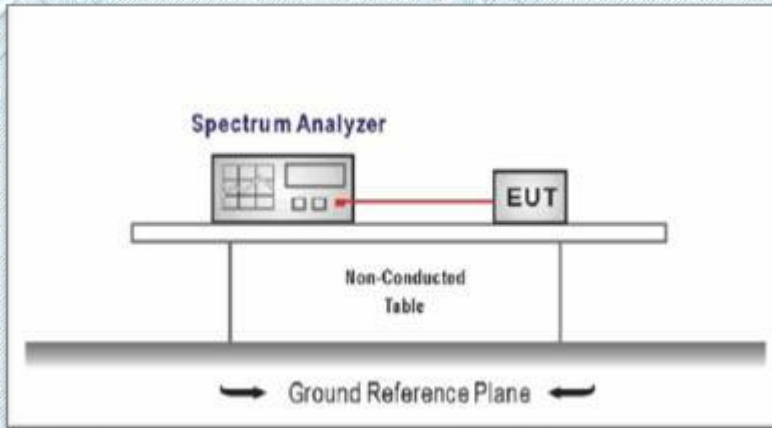

Test Procedure

1. Connect EUT RF output port to the Spectrum Analyzer through an RF attenuator.
2. Spectrum Setting:
 - (1) Spectrum Setting: RBW=1MHz, VBW ≥ RBW.
 - (2) Use video trigger with the trigger level set to enable triggering only on full pulses.
 - (3) Sweep Time is more than once pulse time.
 - (4) Set the center frequency on any frequency would be measure and set the frequency span to zero.
 - (5) Measure the maximum time duration of one single pulse.
 - (6) Set the EUT for packet transmitting.

Test Mode

Please refer to the clause 2.3

Test Result

The 3DH5 modulation is the worst case and recorded in the report.

Test Mode	Channel (MHz)	Pulse Time (ms)	Total of Dwell (ms)	Period Time (s)	Limit (ms)	Result
3DH5	2402	2.87	306.539	31.6	400	PASS

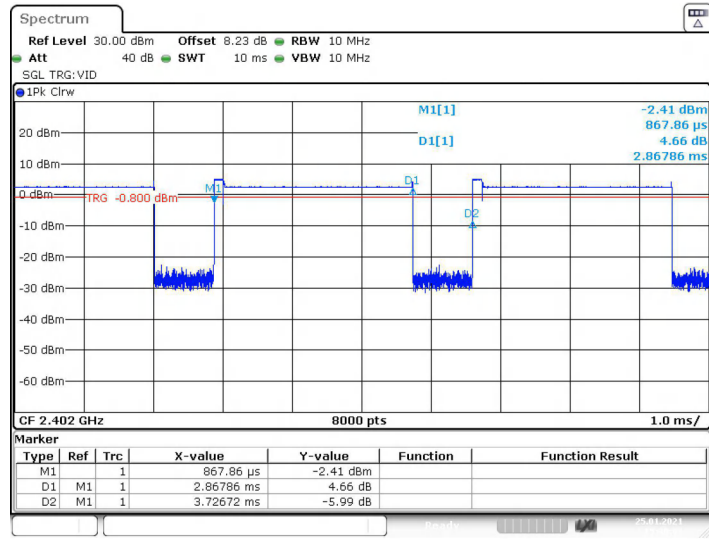

Date: 25.JAN.2021 15:30:03

Test Mode	Channel (MHz)	Pulse Time (ms)	Total of Dwell (ms)	Period Time (s)	Limit (ms)	Result
3DH5	2441	2.87	306.539	31.6	400	PASS

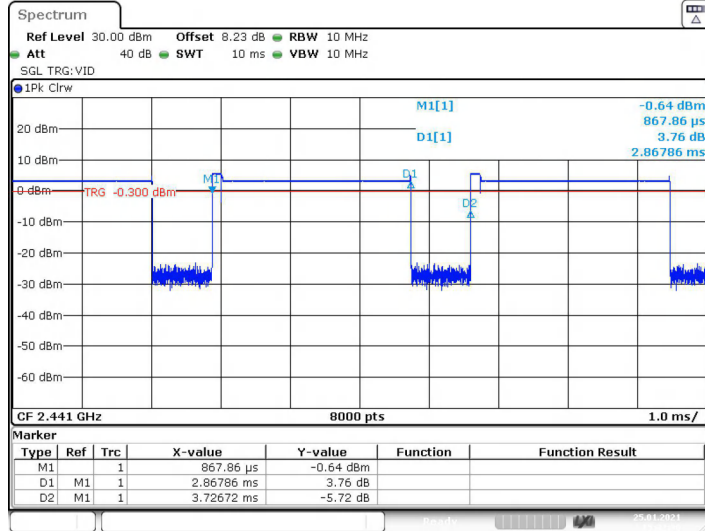

Date: 25.JAN.2021 15:32:29

Test Mode	Channel (MHz)	Pulse Time (ms)	Total of Dwell (ms)	Period Time (s)	Limit (ms)	Result
3DH5	2480	2.87	306.539	31.6	400	PASS

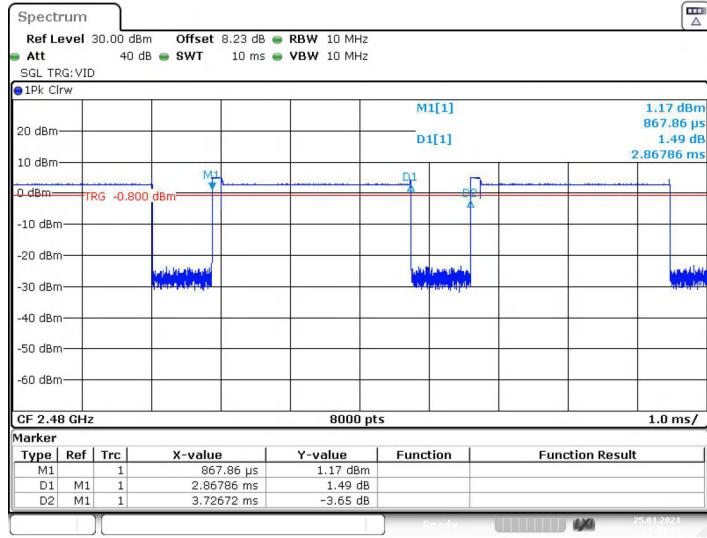

Date: 25.JAN.2021 15:34:09

3.7. Band Edge and Spurious Emission (conducted)

LIMIT

FCC CFR Title 47 Part 15 Subpart C Section 15.247 (d):

In any 100 kHz bandwidth outside the frequency band in which the spread spectrum intentional radiator is operating, the radio frequency power that is produced by the intentional radiator shall be at least 20 dB below that in the 100 kHz bandwidth within the band that contains the highest level of the desired power, based on either an RF conducted or a radiated measurement.

TEST CONFIGURATION

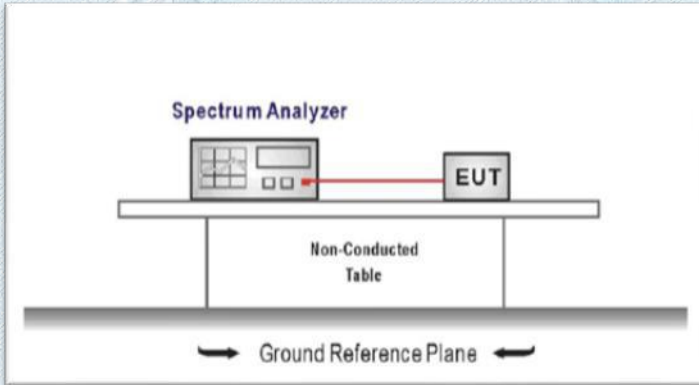

TEST PROCEDURE

1. Connect EUT RF Output port to the Spectrum Analyzer through an RF attenuator.

2. Spectrum Setting:

RBW=100KHz

VBW=3*RBW.

Detector function: Peak.

Trace: Max hold.

Sweep = Auto couple.

Allow the trace to stabilize.

TEST MODE:

Please refer to the clause 2.3.

TEST RESULTS

DH5

CH00-Bandedge

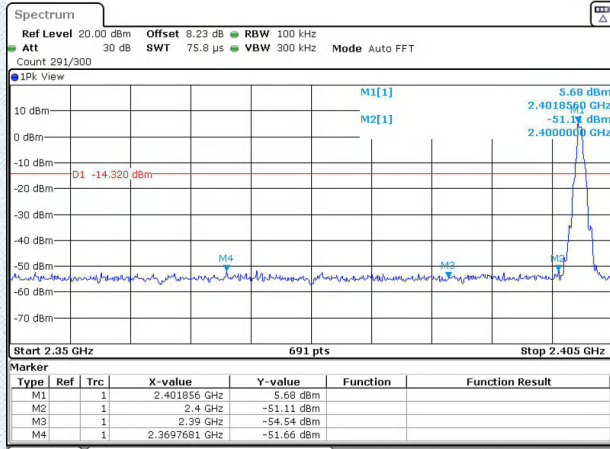

Date: 25.JAN.2021 15:14:53

CH78-Bandedge

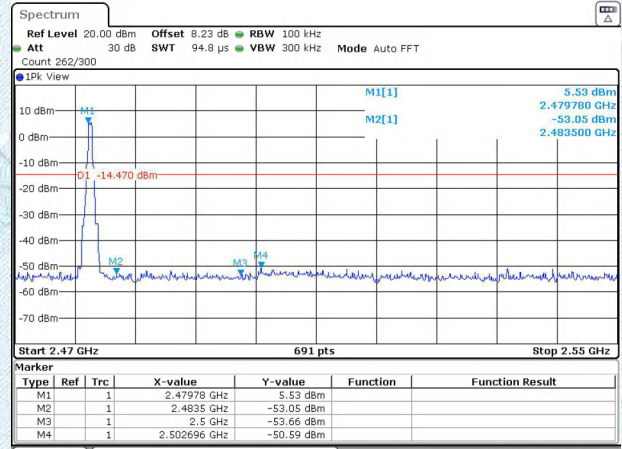

Date: 25.JAN.2021 15:20:27

DH5

CH00-SE

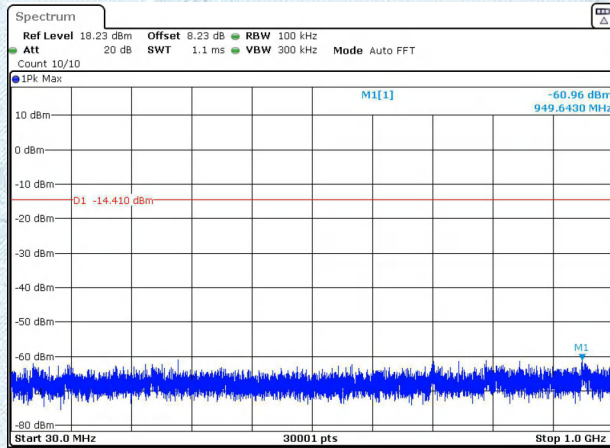

Date: 25.JAN.2021 15:15:57

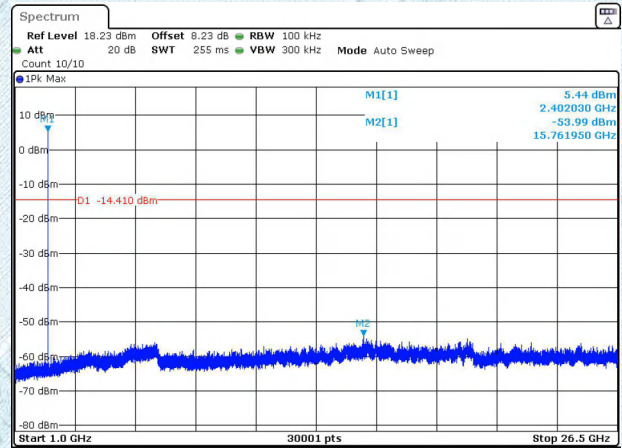

Date: 25.JAN.2021 15:16:20

CH39-SE

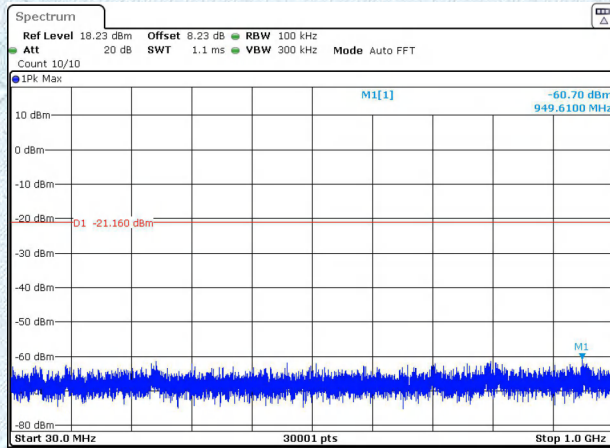

Date: 25.JAN.2021 15:18:27

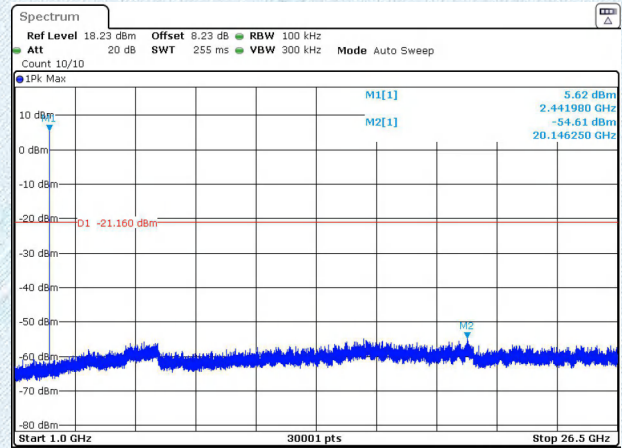

Date: 25.JAN.2021 15:18:49

CH78-SE

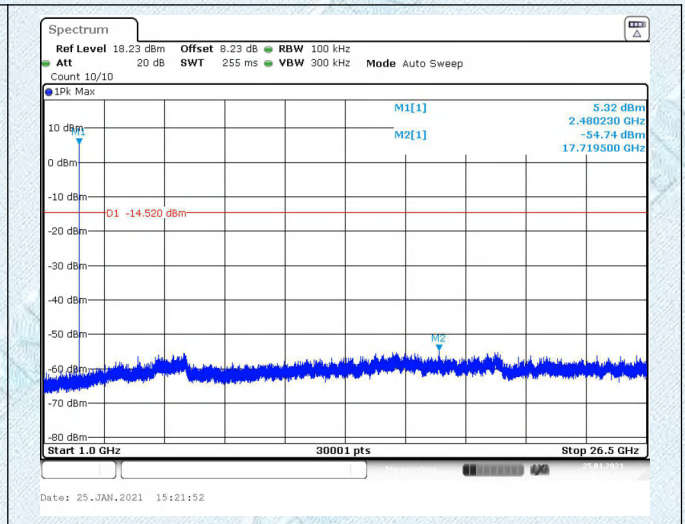
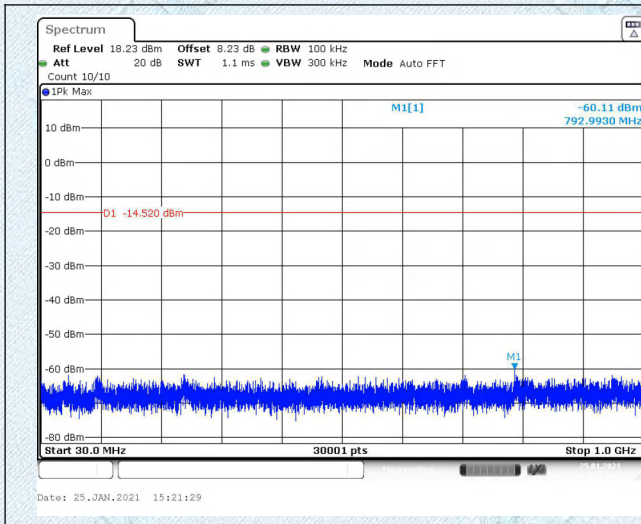

2DH5

CH00-Bandedge

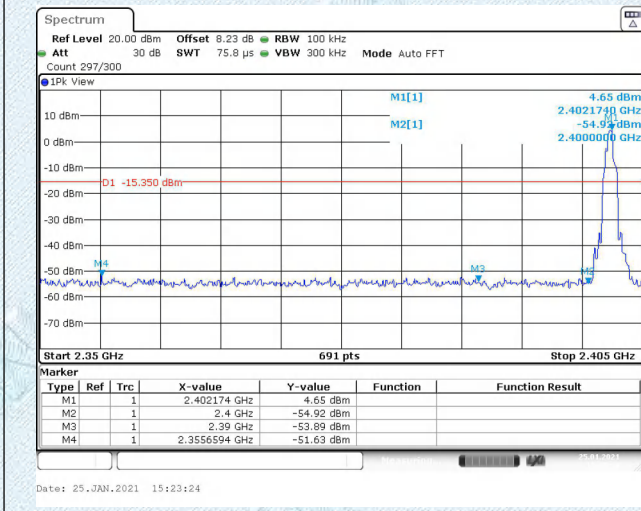

CH78-Bandedge

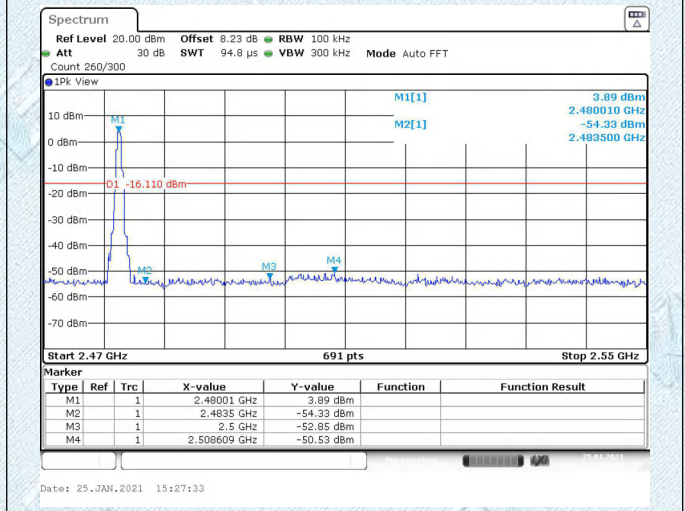

2DH5

CH00-SE

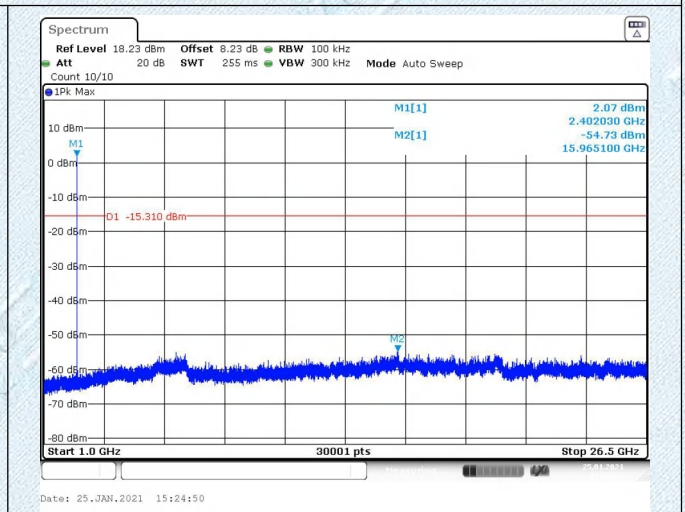
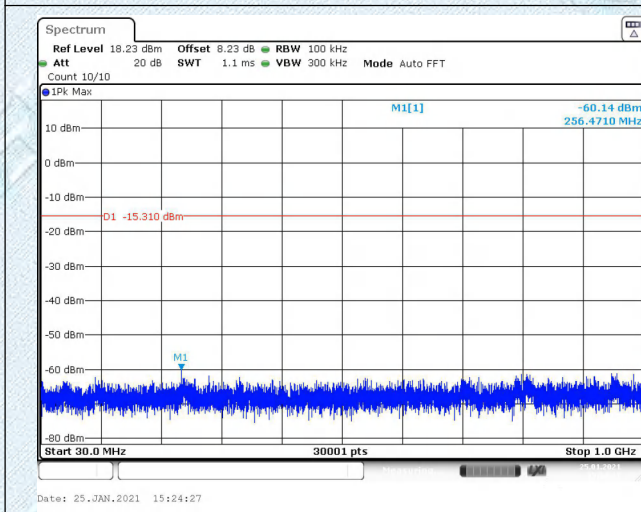

CH39-SE

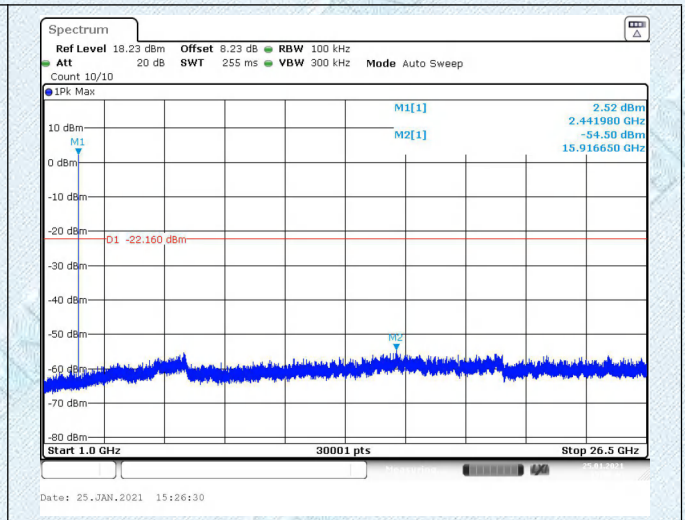
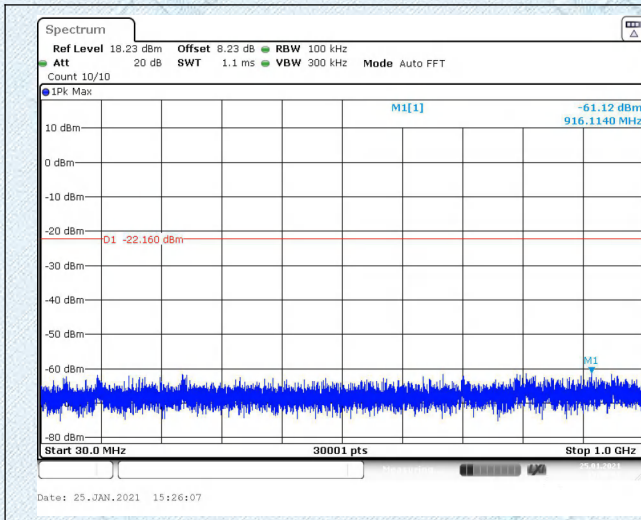

CH78-SE

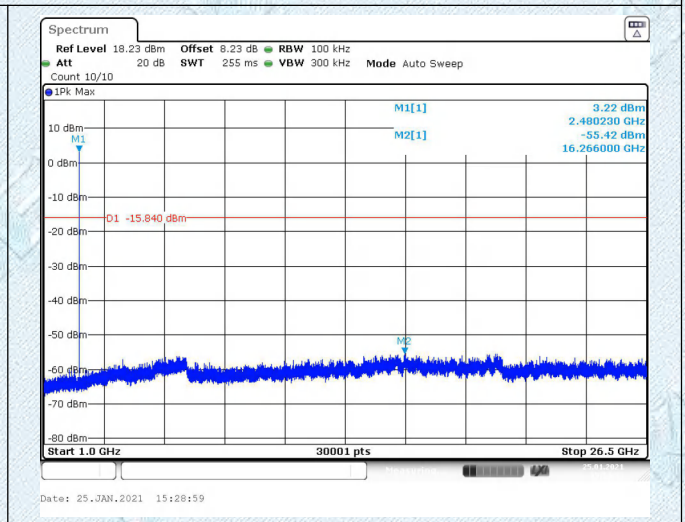
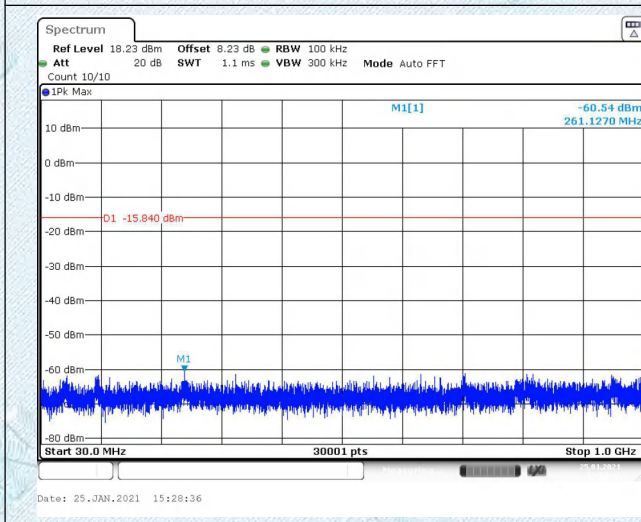

3DH5

CH00-Bandedge

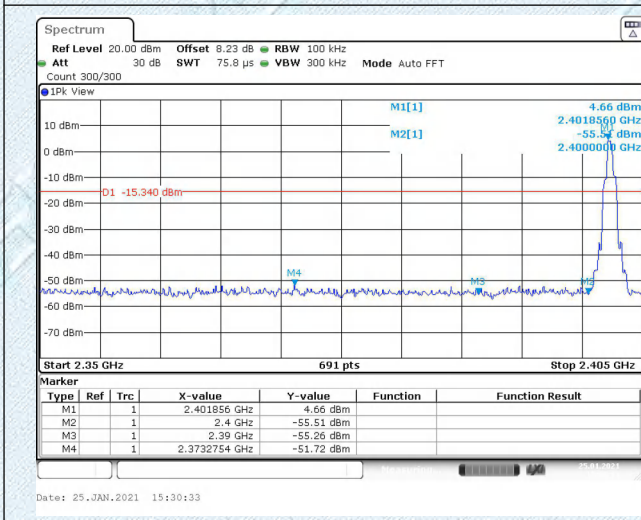

CH78-Bandedge

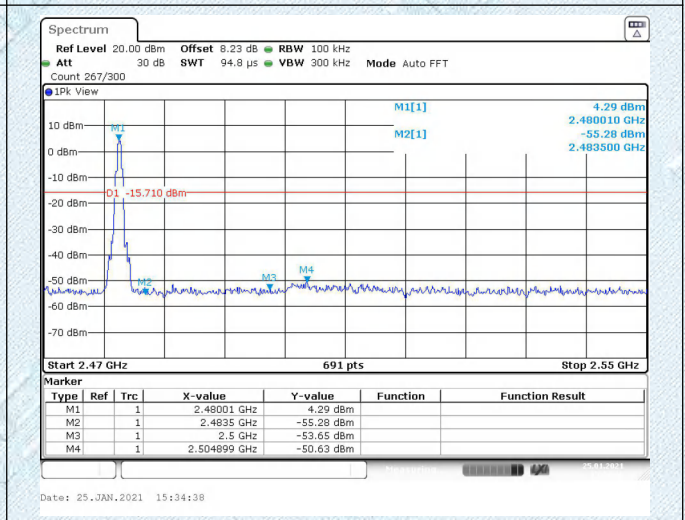

3DH5

CH00-SE

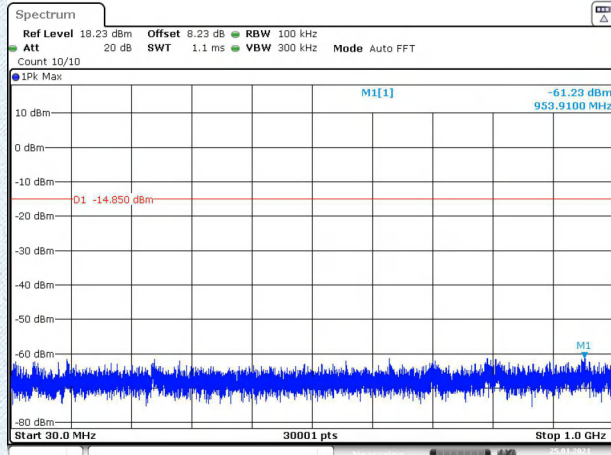

Date: 25.JAN.2021 15:31:35

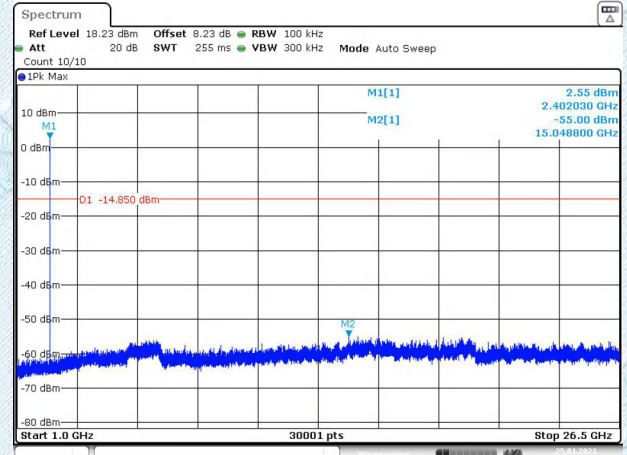

Date: 25.JAN.2021 15:31:58

CH39-SE

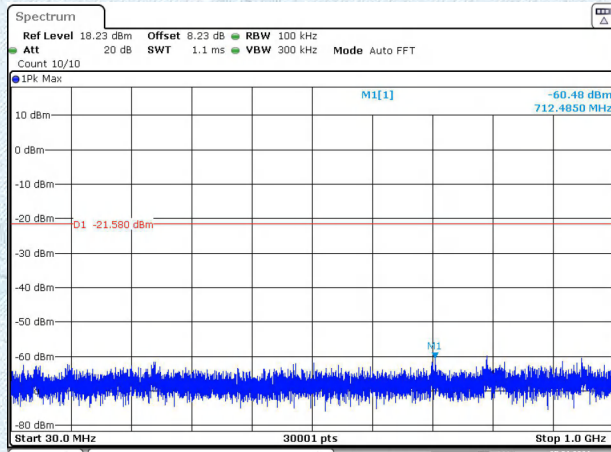

Date: 25.JAN.2021 15:33:01

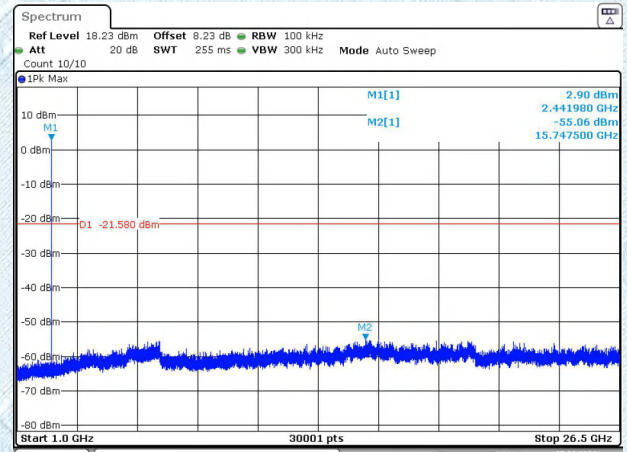

Date: 25.JAN.2021 15:33:24

CH78-SE

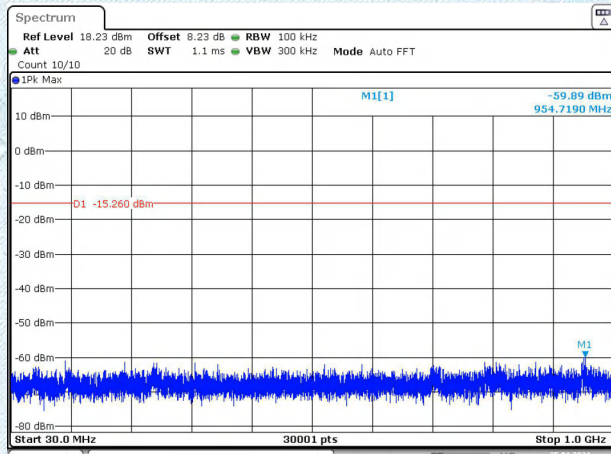

Date: 25.JAN.2021 15:35:43

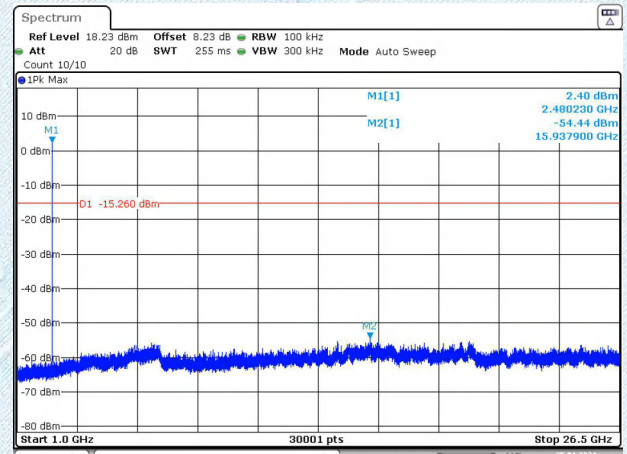

Date: 25.JAN.2021 15:36:04

DH5(2402)-Hopping on

DH5(2480)-Hopping on

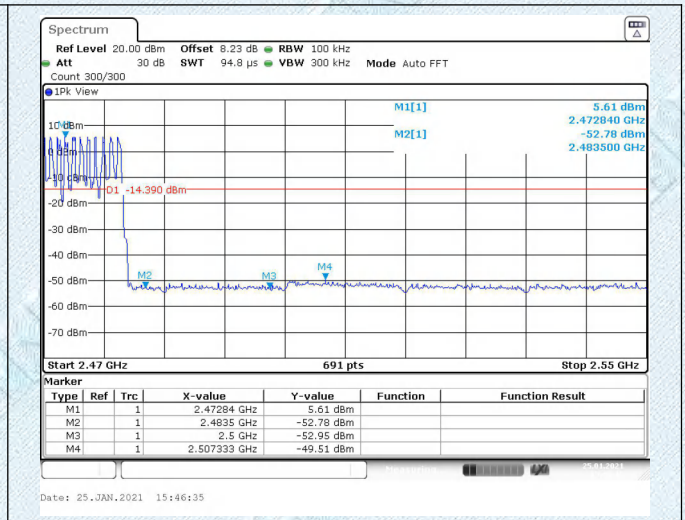
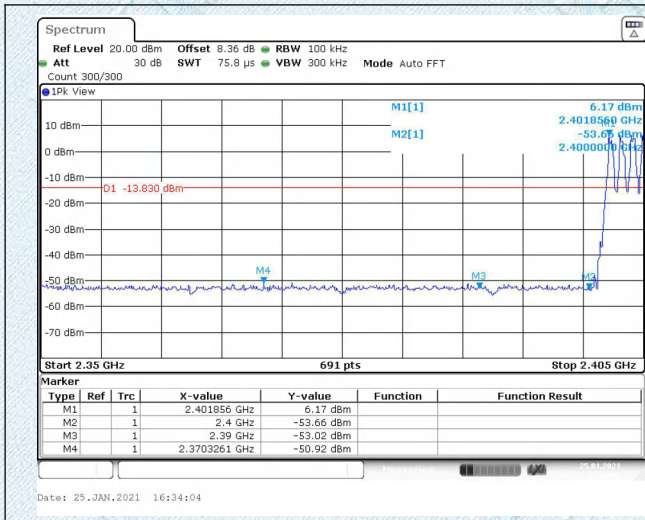

2DH5(2402)-Hopping on

2DH5(2480)-Hopping on

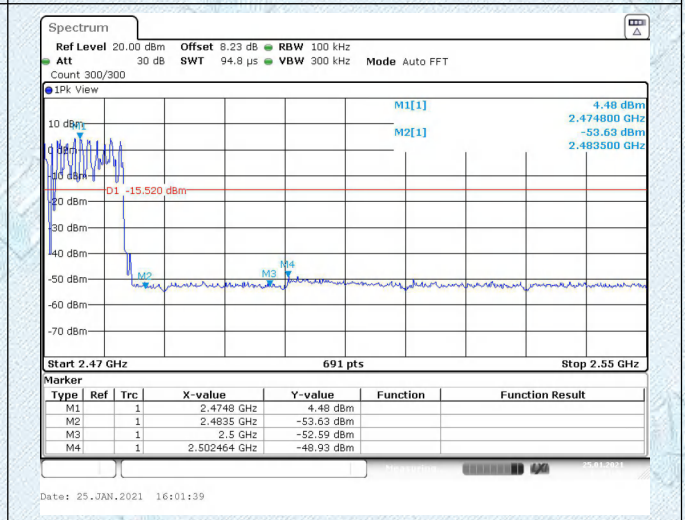
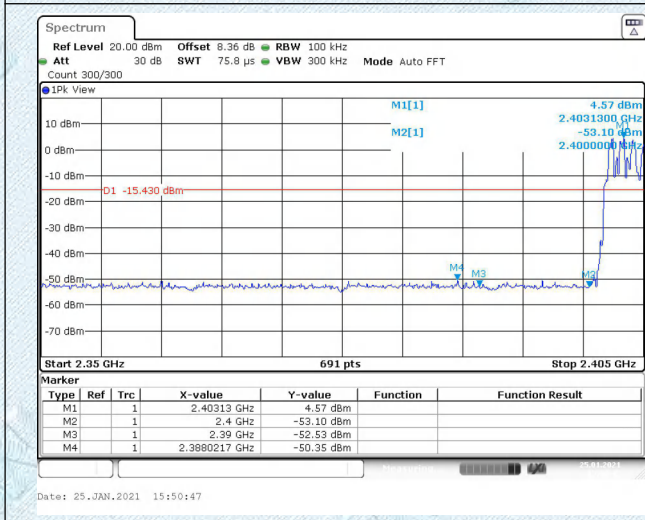

3DH5(2402)-Hopping on

3DH5(2480)-Hopping on

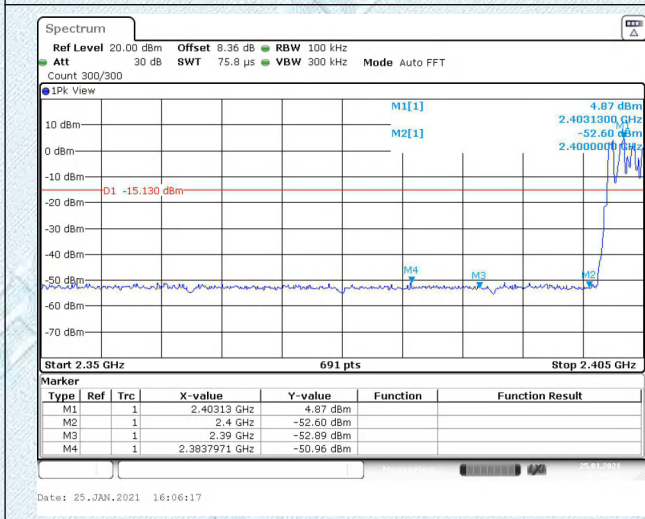

3.8. Band Edge Emissions(Radiated)

Limit

Restricted Frequency Band (MHz)	(dBuV/m)(at 3m)	
	Peak	Average
2310 ~2390	74	54
2483.5 ~2500	74	54

Note: All restriction bands have been tested, only the worst case is reported.

Test Configuration

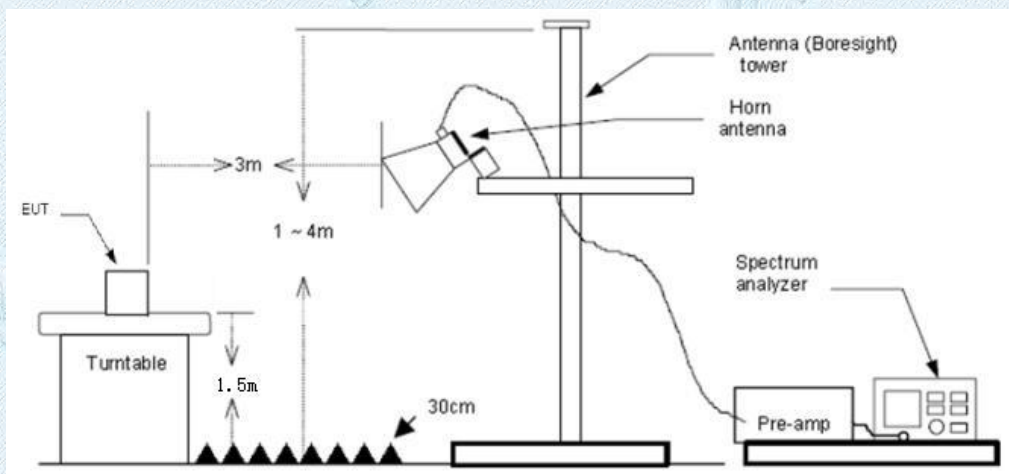

Test Procedure

1. The EUT was setup and tested according to ANSI C63.10:2013 requirements.
2. The EUT is placed on a turn table which is 1.5 meter above ground. The turn table is rotated 360 degrees to determine the position of the maximum emission level.
3. The EUT was positioned such that the distance from antenna to the EUT was 3 meters.
4. The antenna is scanned from 1 meter to 4 meters to find out the maximum emission level. This is repeated for both horizontal and vertical polarization of the antenna. In order to find the maximum emission, all of the interface cables were manipulated according to ANSI C63.10:2013 on radiated measurement.
5. The receiver set as follow:
 RBW=1MHz, VBW=3MHz PEAK detector for Peak value.
 RBW=1MHz, VBW=10Hz with PEAK Detector for Average Value.

Test Mode

Please refer to the clause 2.3.

Test Results

Note:

1. Measurement = Reading level + Correct Factor
2. Correct Factor=Antenna Factor + Cable Loss -Preamplifier Factor
3. Pre-scan DH5, 2DH5 and 3DH5 modulation, and found the DH5 modulation which it is worse case, so only show the test data for worse case.

Test Voltage	3.7V
Ant. Pol.	Horizontal
Test Mode:	DH5 Mode 2402MHz

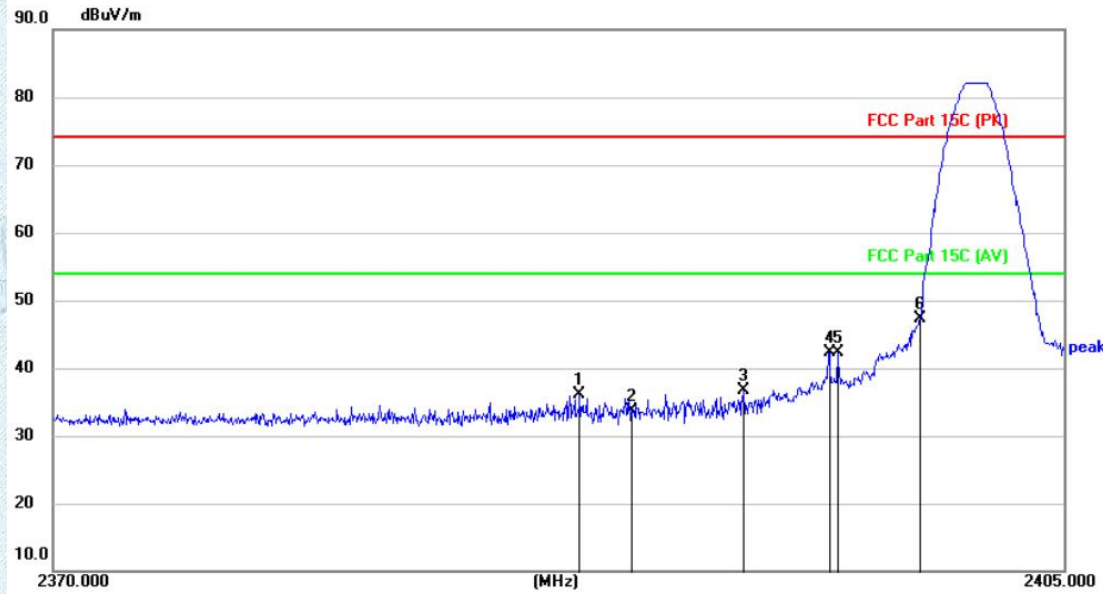

No.	Mk.	Freq. MHz	Reading Level (dBuV)	Correct Factor (dB/m)	Measure- ment (dBuV/m)	Limit (dBuV/m)	Over (dB)	Detector
1		2388.175	47.00	-10.92	36.08	74.00	37.92	peak
2		2390.000	44.66	-10.92	33.74	74.00	40.26	peak
3		2393.856	47.63	-10.92	36.71	74.00	37.29	peak
4		2396.841	53.19	-10.92	42.27	74.00	31.73	peak
5		2397.135	53.18	-10.92	42.26	74.00	31.74	peak
6	*	2400.000	58.27	-10.92	47.35	74.00	26.65	peak

Measurement = Reading level + Correct Factor

Test Voltage	3.7V
Ant. Pol.	Vertical
Test Mode:	DH5 Mode 2402 MHz

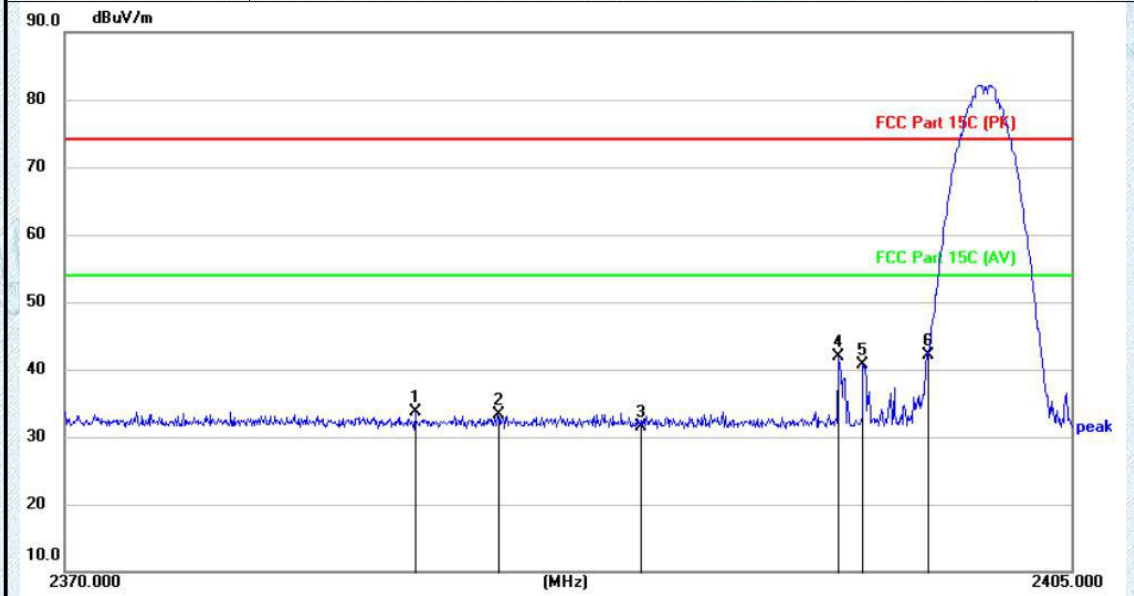

No.	Mk.	Freq. MHz	Reading Level (dBuV)	Correct Factor (dB/m)	Measure- ment (dBuV/m)	Limit (dBuV/m)	Over (dB)	Detector
1		2382.135	44.53	-10.92	33.61	74.00	40.39	peak
2		2385.012	44.17	-10.92	33.25	74.00	40.75	peak
3		2390.000	42.42	-10.92	31.50	74.00	42.50	peak
4		2396.869	52.87	-10.92	41.95	74.00	32.05	peak
5		2397.744	51.65	-10.92	40.73	74.00	33.27	peak
6	*	2400.000	53.06	-10.92	42.14	74.00	31.86	peak

Measurement = Reading level + Correct Factor

Test Voltage	3.7V
Ant. Pol.	Horizontal
Test Mode:	DH5 Mode 2480MHz

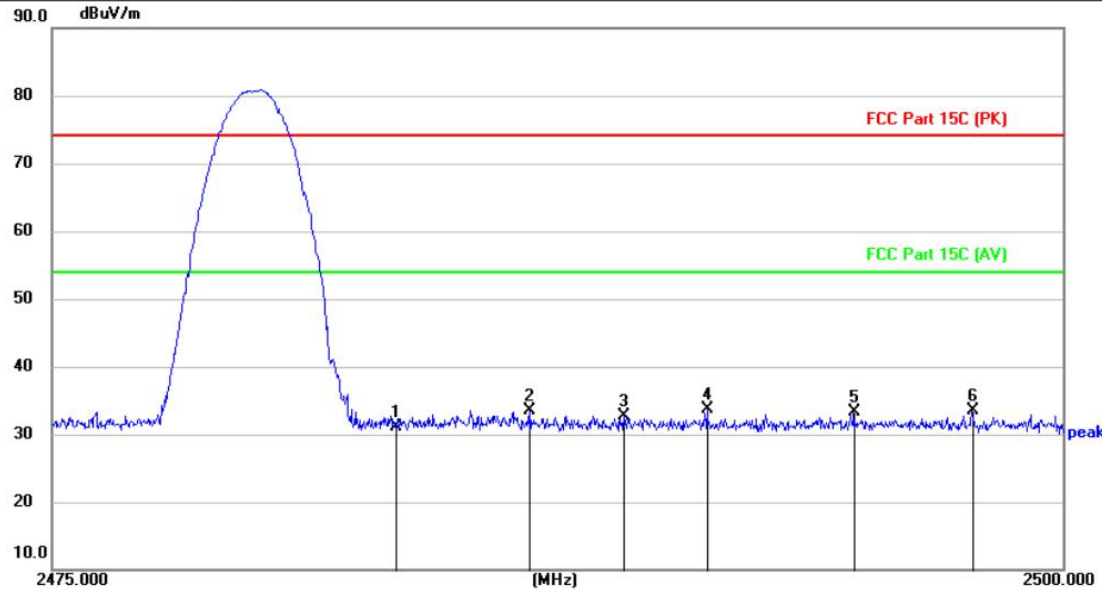

No.	Mk.	Freq. MHz	Reading Level (dBuV)	Correct Factor (dB/m)	Measure- ment (dBuV/m)	Limit (dBuV/m)	Over (dB)	Detector
1		2483.500	42.07	-10.88	31.19	74.00	42.81	peak
2		2486.802	44.41	-10.88	33.53	74.00	40.47	peak
3		2489.122	43.63	-10.89	32.74	74.00	41.26	peak
4	*	2491.193	44.65	-10.89	33.76	74.00	40.24	peak
5		2494.813	44.12	-10.87	33.25	74.00	40.75	peak
6		2497.745	44.42	-10.88	33.54	74.00	40.46	peak

Measurement = Reading level + Correct Factor

Test Voltage	3.7V
Ant. Pol.	Vertical
Test Mode:	DH5 Mode 2480 MHz

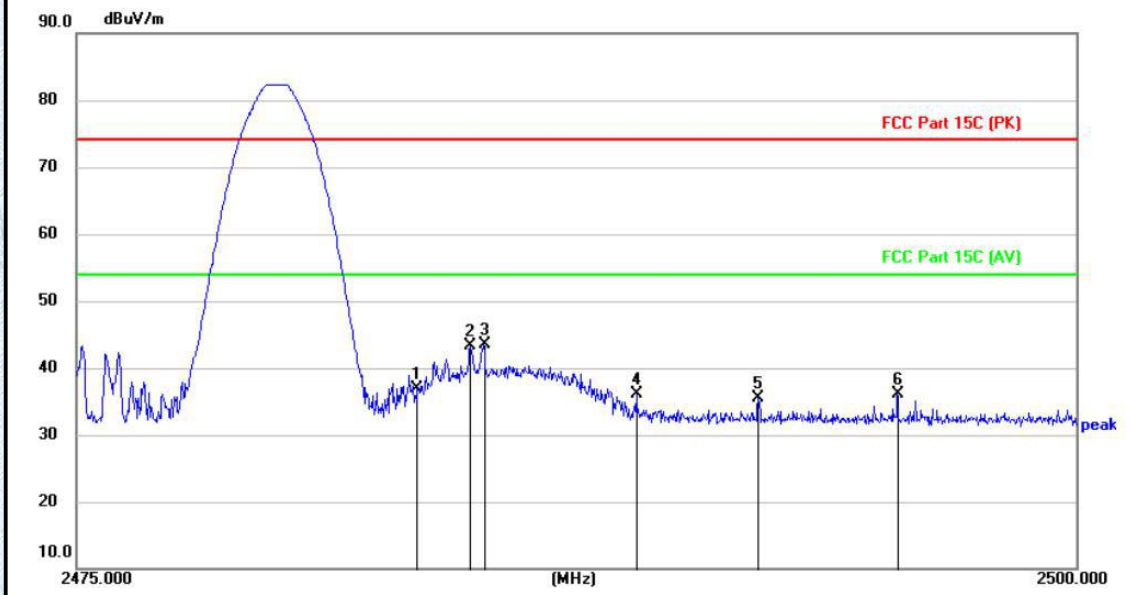

No.	Mk.	Freq. MHz	Reading Level (dBuV)	Correct Factor (dB/m)	Measure- ment (dBuV/m)	Limit (dBuV/m)	Over (dB)	Detector
1		2483.500	47.75	-10.88	36.87	74.00	37.13	peak
2		2484.832	54.28	-10.88	43.40	74.00	30.60	peak
3	*	2485.153	54.34	-10.88	43.46	74.00	30.54	peak
4		2488.970	47.04	-10.89	36.15	74.00	37.85	peak
5		2492.040	46.33	-10.89	35.44	74.00	38.56	peak
6		2495.528	46.94	-10.87	36.07	74.00	37.93	peak

Measurement = Reading level + Correct Factor

3.9. Radiated Spurious Emissions

Limit

Radiated Emission Limits (9 kHz~1000 MHz)

Frequency (MHz)	Field Strength (microvolt/meter)	Measurement Distance (meters)
0.009~0.490	2400/F(KHz)	300
0.490~1.705	24000/F(KHz)	30
1.705~30.0	30	30
30~88	100	3
88~216	150	3
216~960	200	3
Above 960	500	3

Radiated Emission Limit (Above 1000MHz)

Frequency (MHz)	Distance Meters(at 3m)	
	Peak	Average
Above 1000	74	54

Note:

- (1) The tighter limit applies at the band edges.
- (2) Emission Level (dBuV/m)=20log Emission Level (uV/m).

Test Configuration

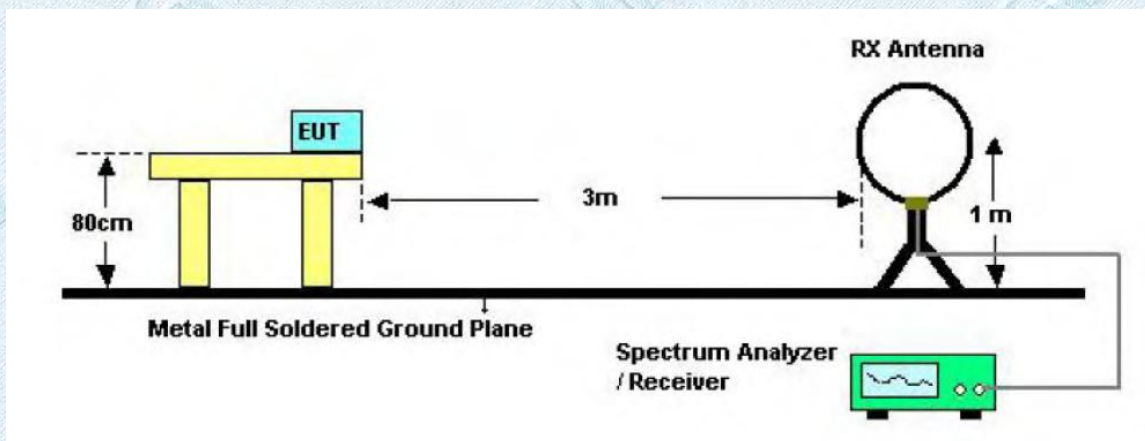

Below 30MHz Test Setup

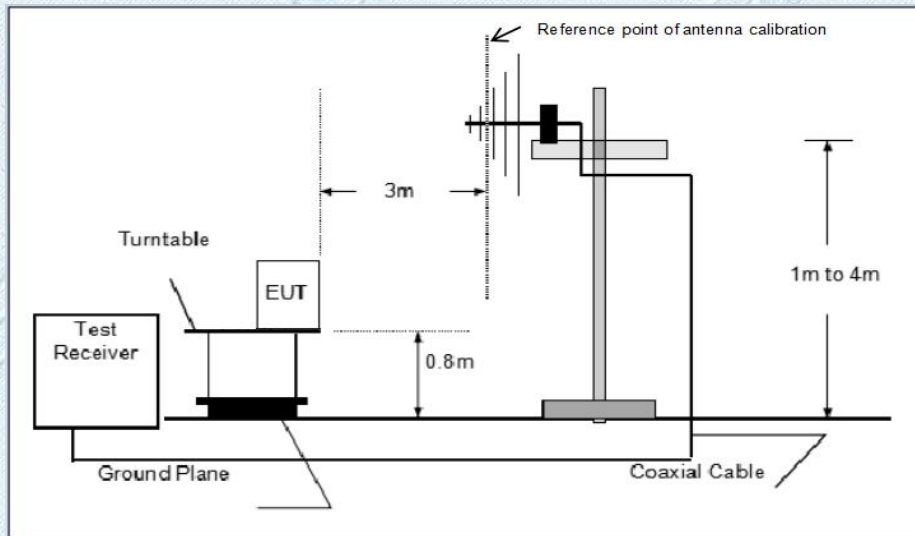

Below 1000MHz Test Setup

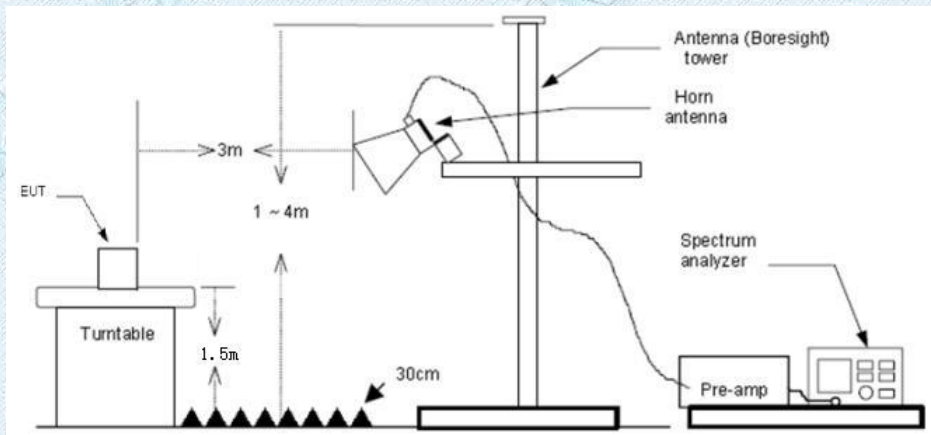

Above 1GHz Test Setup

Test Procedure

1. The EUT was setup and tested according to ANSI C63.10:2013
2. The EUT is placed on a turn table which is 0.8 meter above ground for below 1 GHz, and 1.5 m for above 1 GHz. The turn table is rotated 360 degrees to determine the position of the maximum emission level.
3. The EUT was set 3 meters from the receiving antenna, which was mounted on the top of a variable height antenna tower.
4. For each suspected emission, the EUT was arranged to its worst case and then tune the Antenna tower (from 1 m to 4 m) and turntable (from 0 degree to 360 degrees) to find the maximum reading. A pre-amp and a high pass filter are used for the test in order to get better signal level to comply with the guidelines.
5. Set to the maximum power setting and enable the EUT transmit continuously.
6. Use the following spectrum analyzer settings
 - (1) Span shall wide enough to fully capture the emission being measured;
 - (2) Below 1 GHz:
 RBW=120 kHz, VBW=300 kHz, Sweep=auto, Detector function=peak, Trace=max hold;
 If the emission level of the EUT measured by the peak detector is 3 dB lower than the applicable limit, the peak emission level will be reported. Otherwise, the emission measurement will be repeated using the quasi-peak detector and reported.
 - (3) From 1 GHz to 10th harmonic:
 RBW=1MHz, VBW=3MHz Peak detector for Peak value.
 RBW=1MHz, VBW=10Hz Peak detector for Average value.

Test Mode

Please refer to the clause 2.3.

Test Result**9 KHz~30 MHz and 18GHz~25GHz**

From 9 KHz~30 MHz and 18GHz~25GHz: Conclusion: PASS

Note:

- 1) Measurement = Reading level + Correct Factor
Correct Factor=Antenna Factor + Cable Loss -Preamplifier Factor
- 2) The peak level is lower than average limit(54 dBuV/m), this data is the too weak instrument of signal is unable to test.
- 3) The emission levels of other frequencies are very lower than the limit and not show in test report.
- 4) The amplitude of spurious emissions which are attenuated by more than 20dB below the permissible value has no need to be reported.
- 5) Pre-scan DH5, 2DH5 and 3DH5 modulation, found the DH5-CH39 Channel Below 1GHz and found the DH5 modulation which it is worse case for above 1GHz, so only show the test data for worse case.

RADIATED EMISSION BELOW 30MHZ

No emission found between lowest internal used/generated frequencies to 30MHz.

30MHz-1GHz

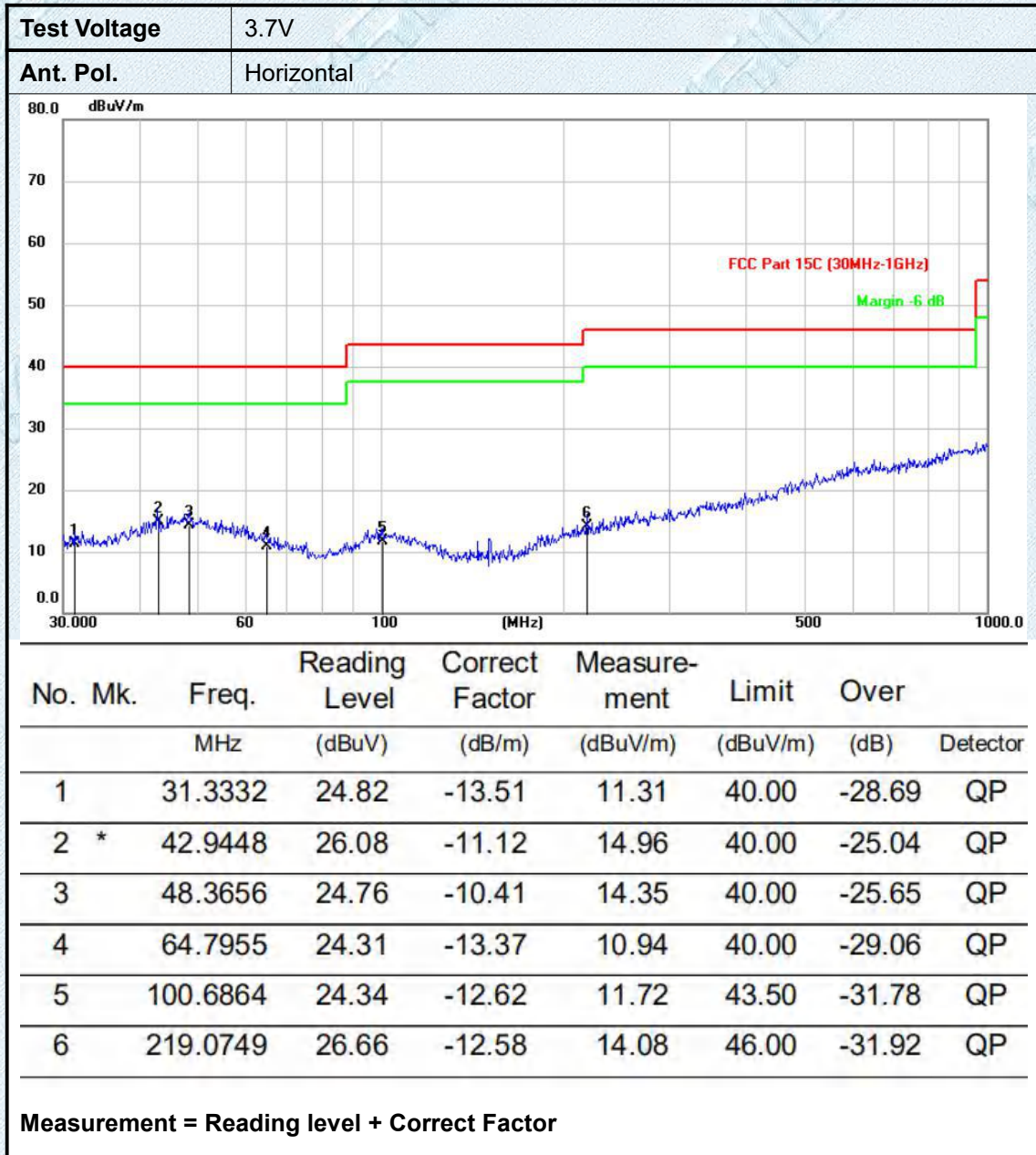

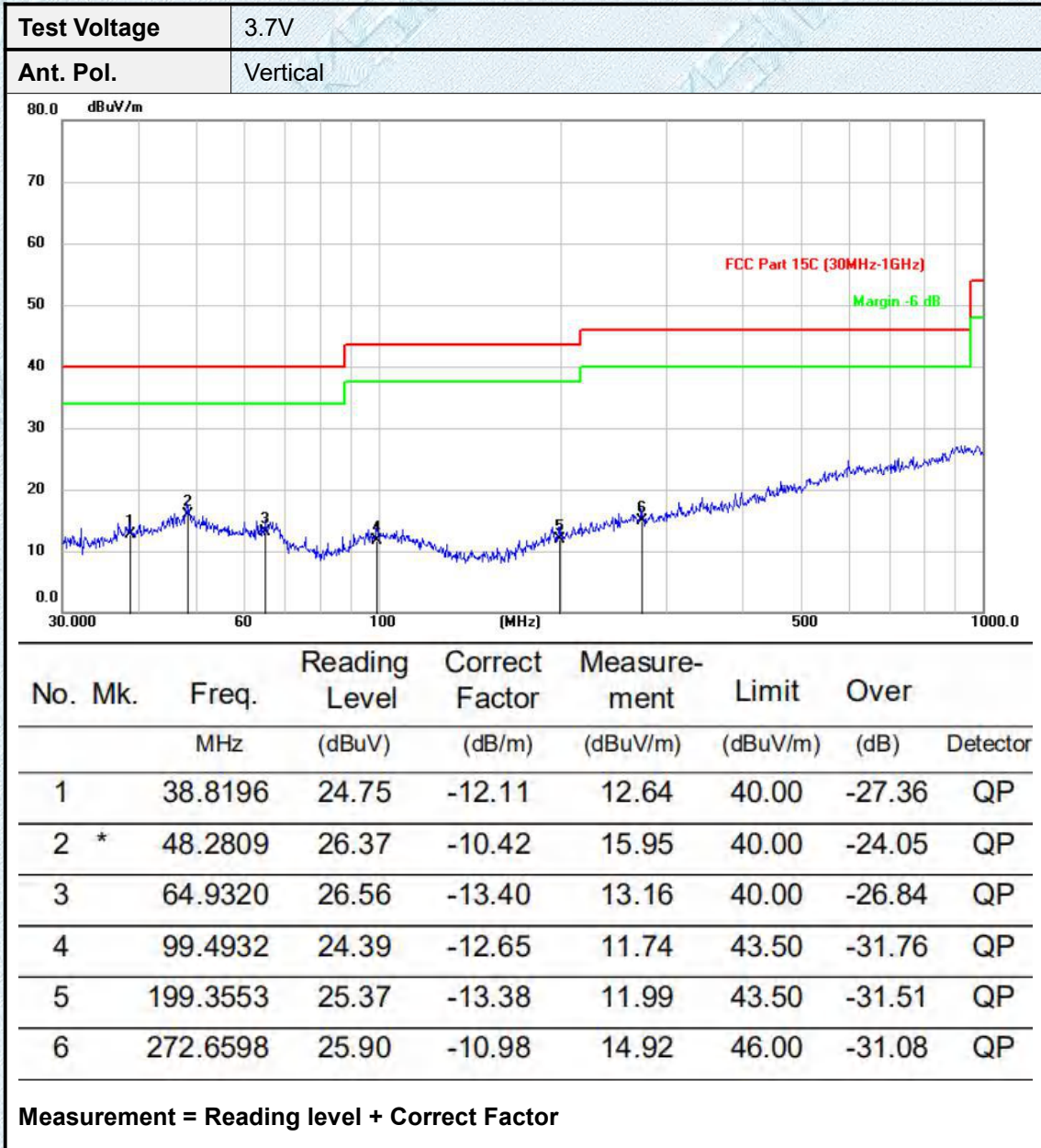

Adobe 1GHz

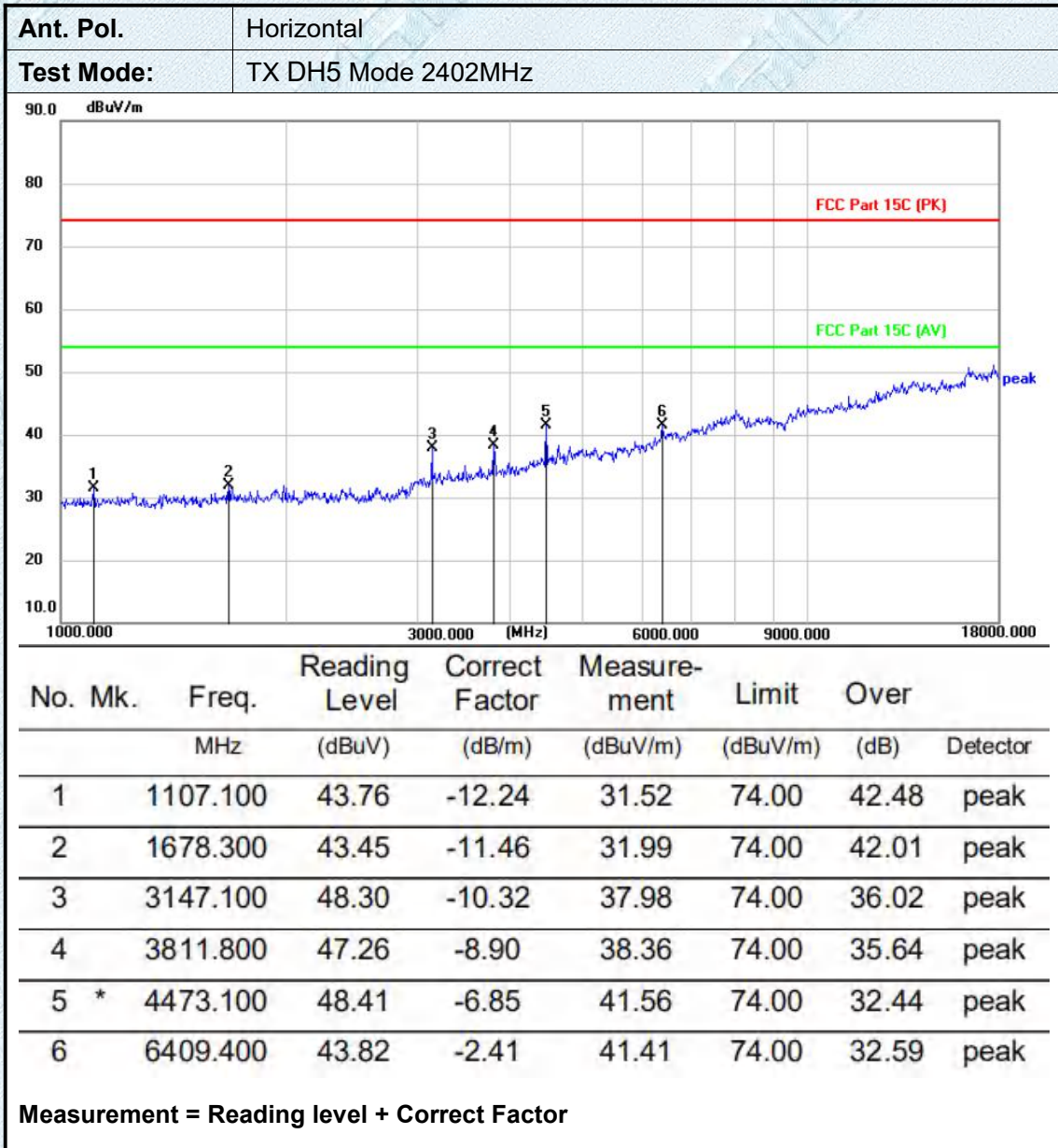

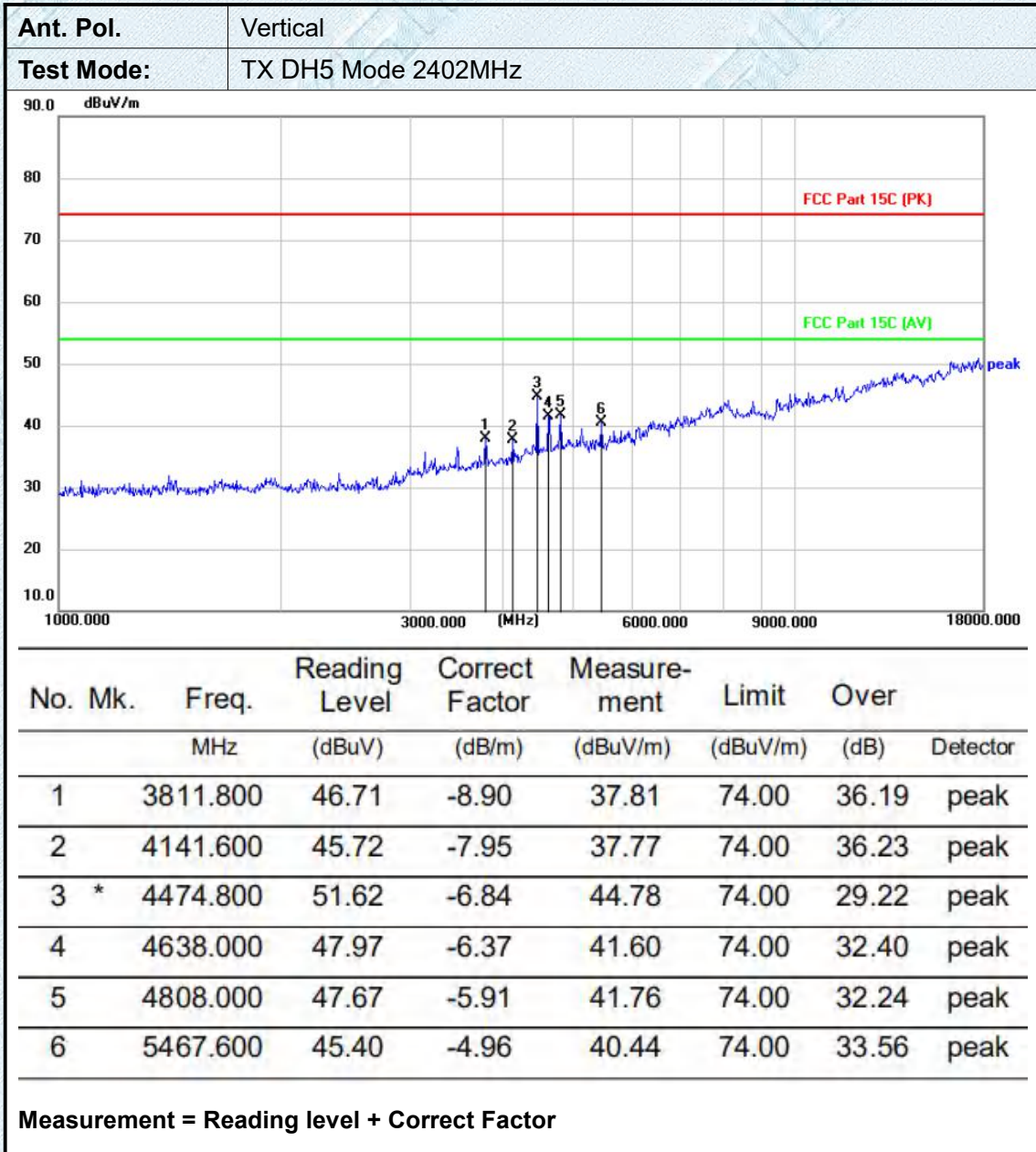

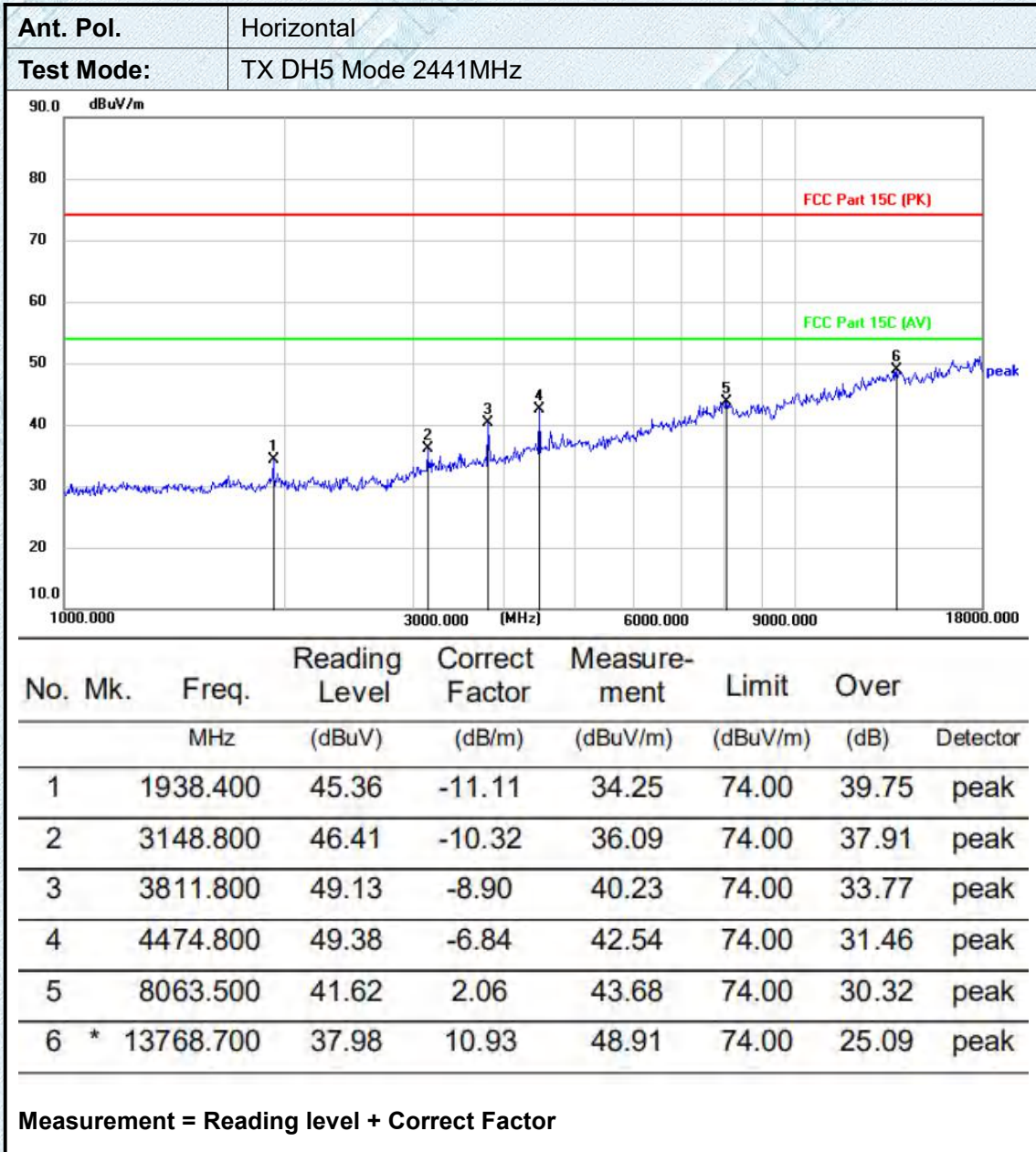

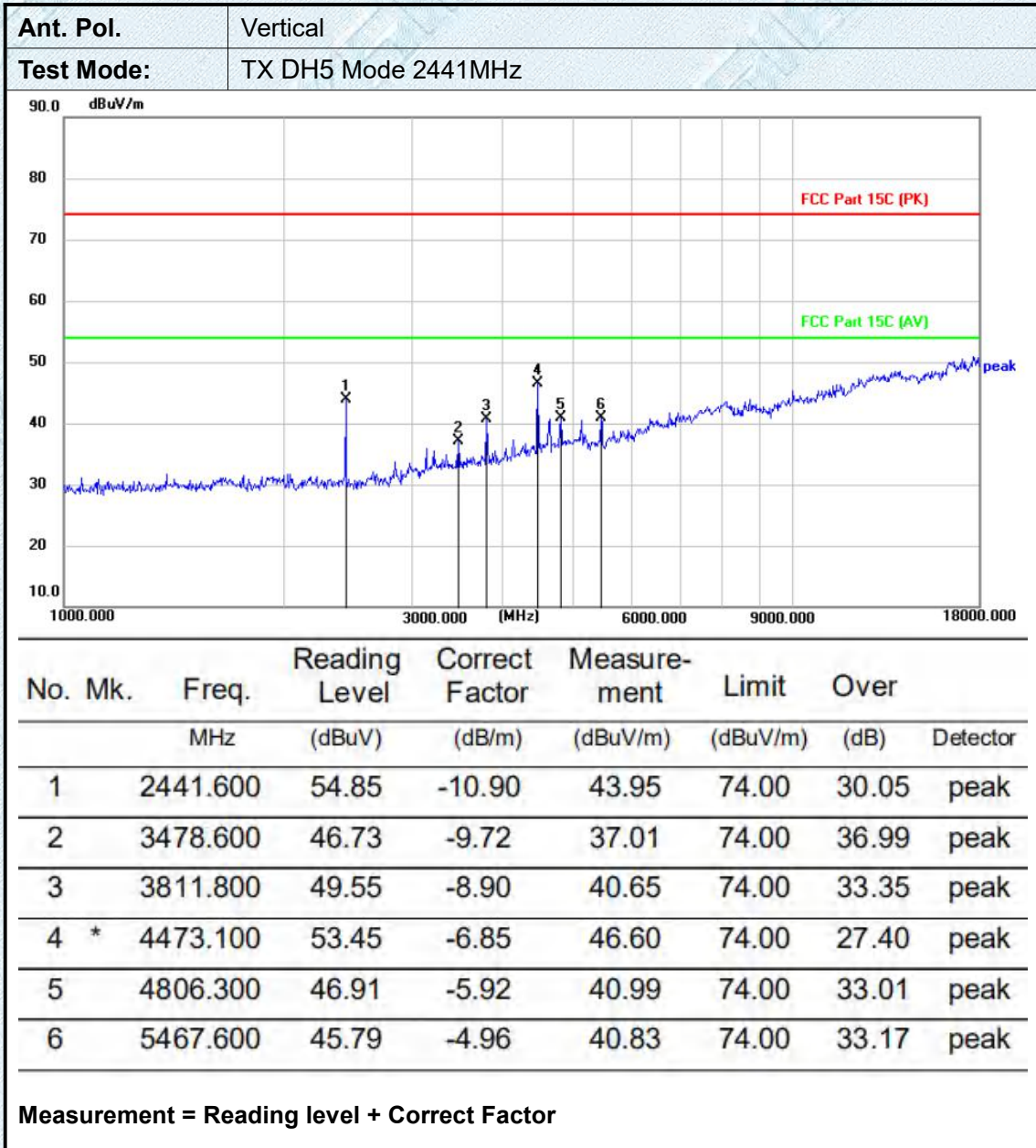

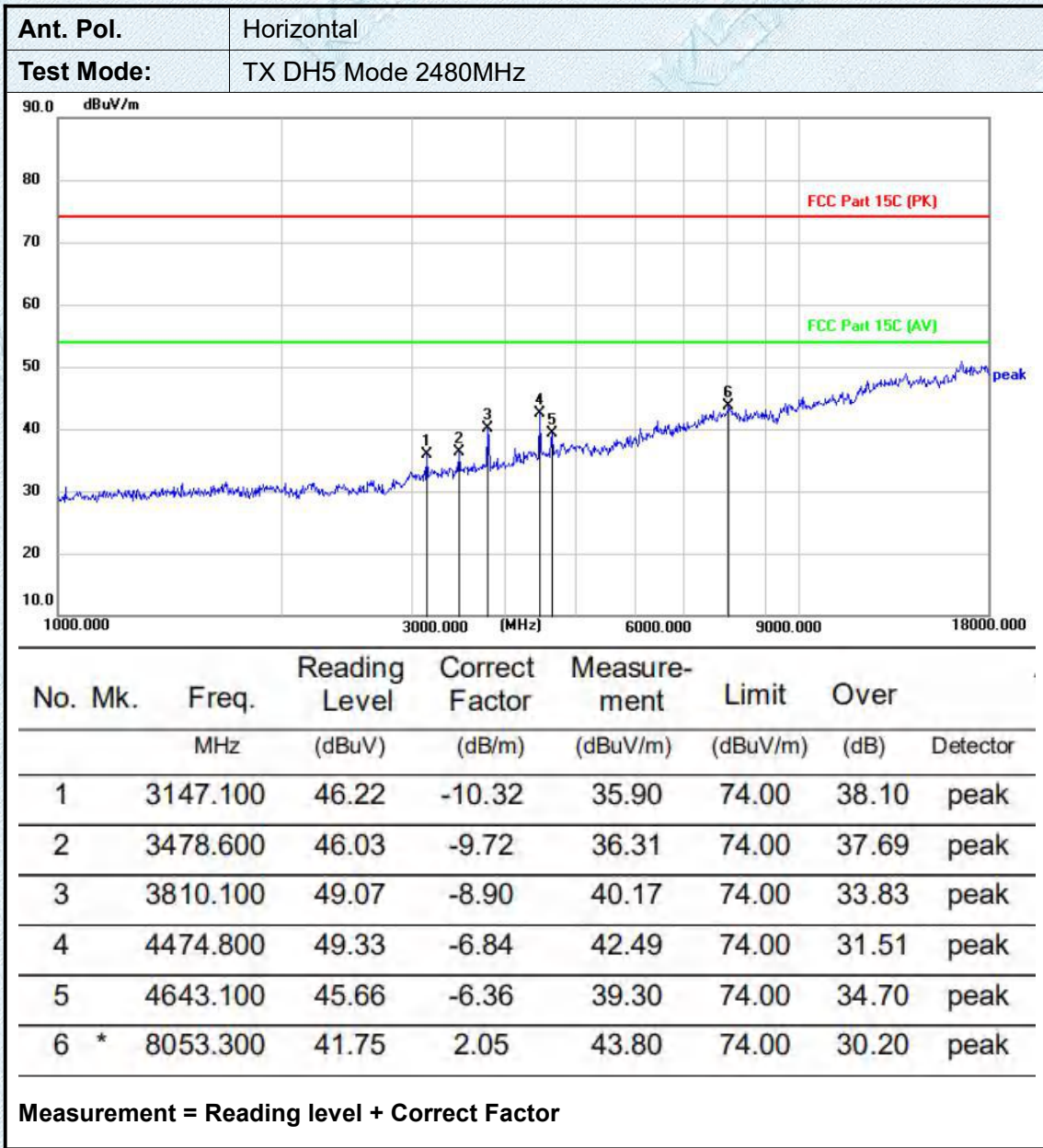

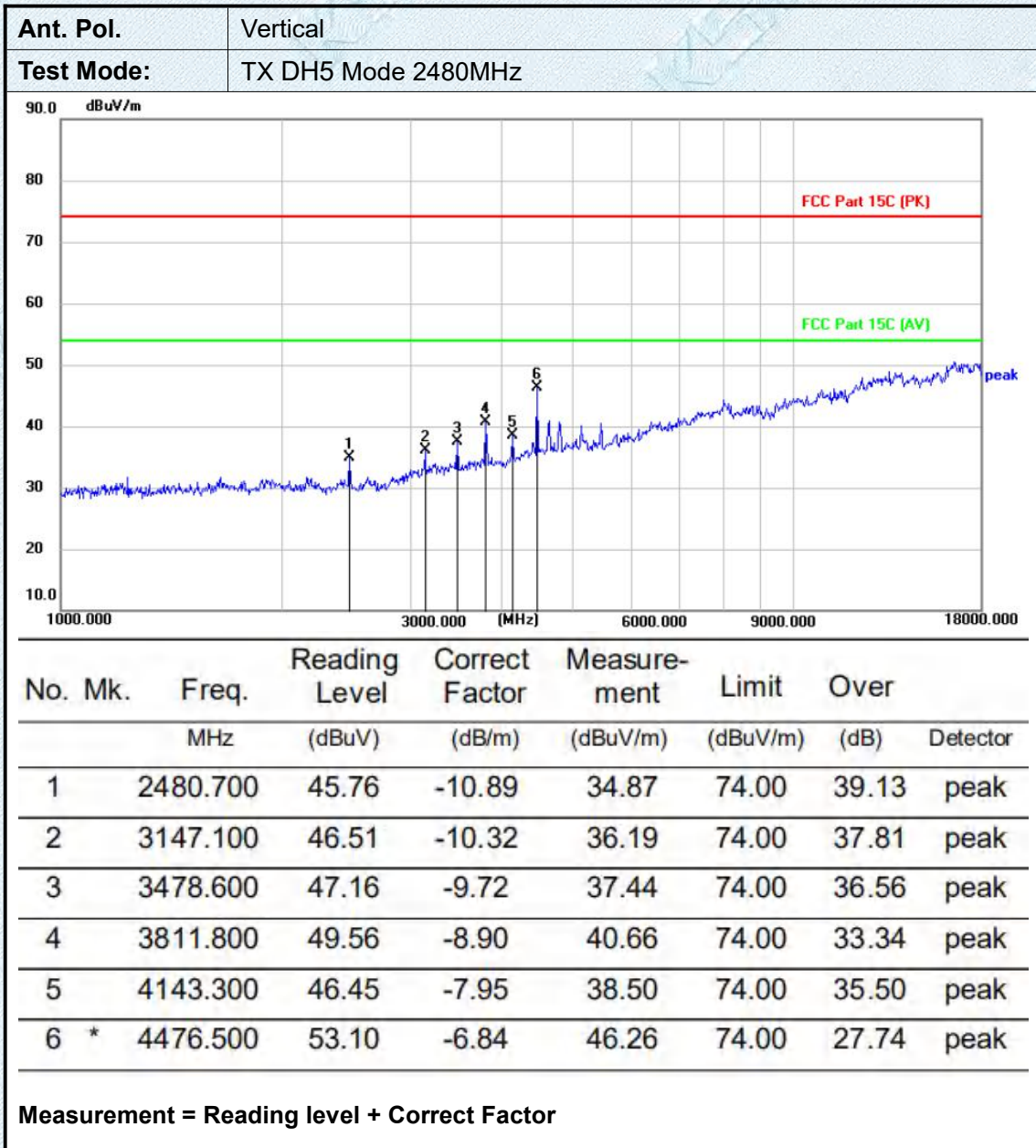

Note:

1. All test modes had been tested. The GFSK(DH5) modulation is the worst case and recorded in the report.
2. The main frequency has been screened by the filter.

3.10. Conducted Emission

Limit

Conducted Emission Test Limit

Frequency	Maximum RF Line Voltage (dB μ V)	
	Quasi-peak Level	Average Level
150kHz~500kHz	66 ~ 56 *	56 ~ 46 *
500kHz~5MHz	56	46
5MHz~30MHz	60	50

Notes:

- (1) *Decreasing linearly with logarithm of the frequency.
- (2) The lower limit shall apply at the transition frequencies.
- (3) The limit decrease in line with the logarithm of the frequency in the range of 0.15 to 0.50MHz.

Test Configuration

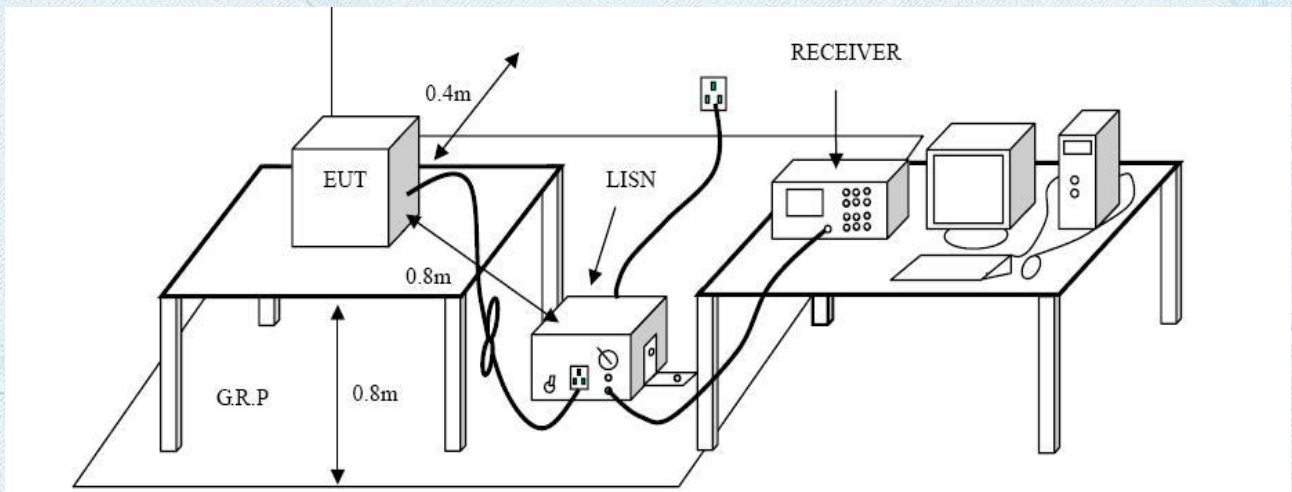

Test Procedure

1. The EUT was setup according to ANSI C63.10:2013 requirements.
2. The EUT was placed on a platform of nominal size, 1 m by 1.5 m, raised 80 cm above the conducting ground plane. The vertical conducting plane was located 40 cm to the rear of the EUT. All other surfaces of EUT were at least 80 cm from any other grounded conducting surface.
3. The EUT and simulators are connected to the main power through a line impedances stabilization network (LISN). The LISN provides a 50ohm /50uH coupling impedance for the measuring equipment. The peripheral devices are also connected to the main power through a LISN. (Please refer to the block diagram of the test setup and photographs)
4. Each current-carrying conductor of the EUT power cord, except the ground (safety) conductor, was individually connected through a LISN to the input power source.
5. The excess length of the power cord between the EUT and the LISN receptacle were folded back and forth at the center of the lead to form a bundle not exceeding 40 cm in length.
6. Conducted Emissions were investigated over the frequency range from 0.15MHz to 30MHz using a receiver bandwidth of 9 kHz.
7. During the above scans, the emissions were maximized by cable manipulation.

Test Mode:

Please refer to the clause 2.3.

Test Results

Pre-scan DH5, 2DH5,3DH5 modulation, and found the DH5 modulation 2402MHz which it is worse case, so only show the test data for worse case.

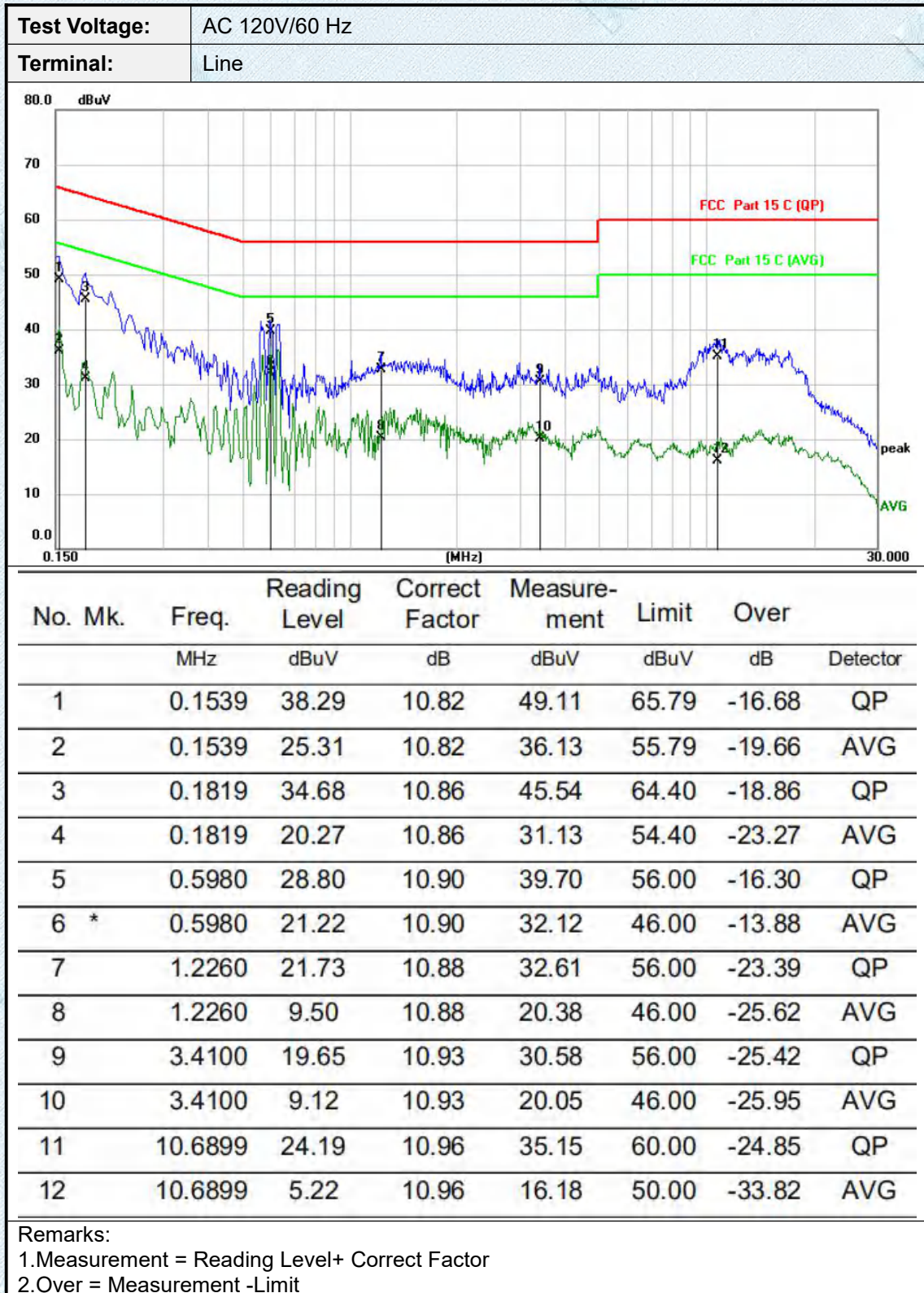

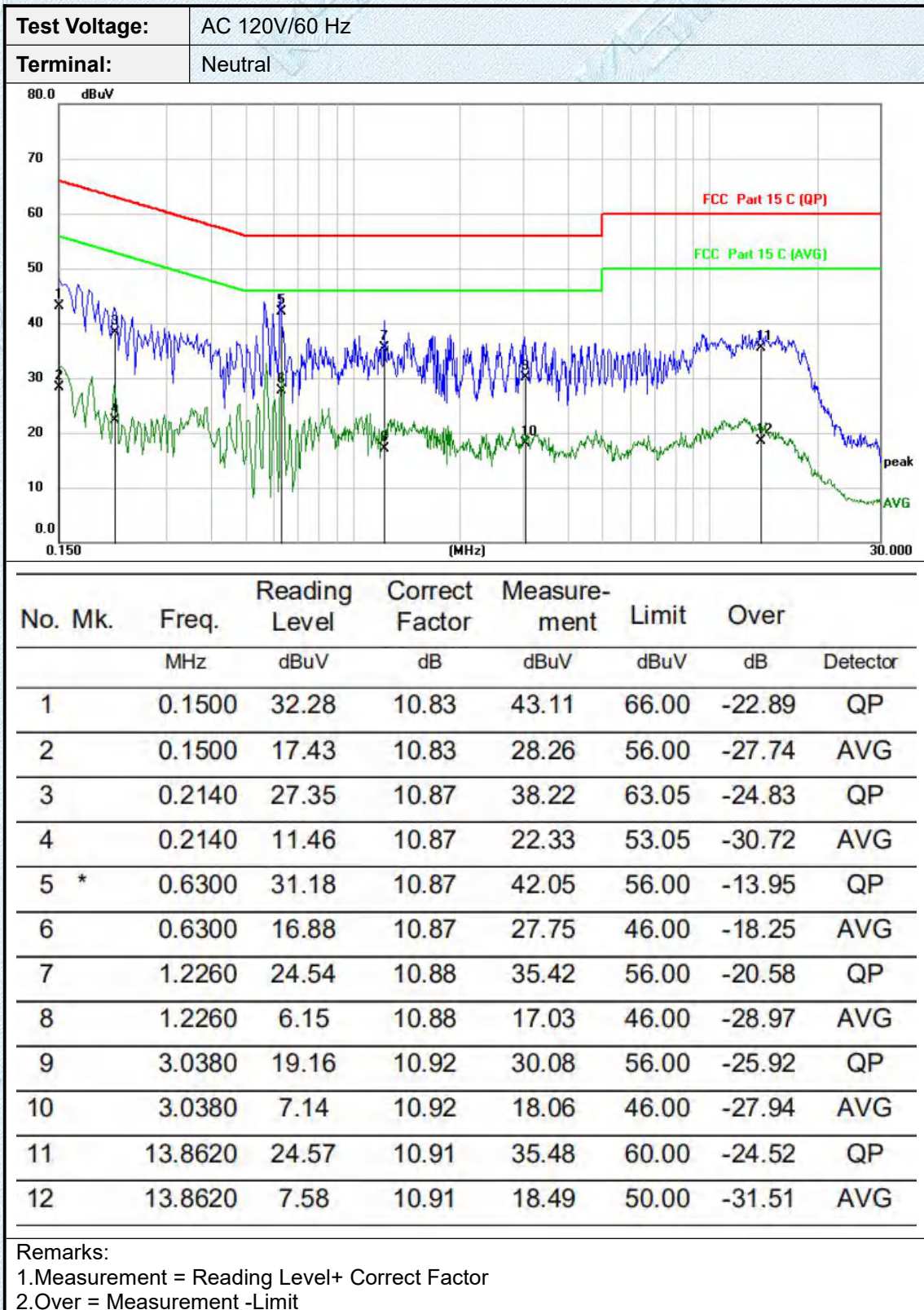

3.11. Pseudorandom Frequency Hopping Sequence

LIMIT

FCC CFR Title 47 Part 15 Subpart C Section 15.247 (a)(1):

Frequency hopping systems shall have hopping channel carrier frequencies separated by a minimum of 25 kHz or the 20 dB bandwidth of the hopping channel, whichever is greater. Alternatively, frequency hopping systems operating in the 2400–2483.5 MHz band may have hopping channel carrier frequencies that are separated by 25 kHz or two-thirds of the 20 dB bandwidth of the hopping channel, whichever is greater, provided the systems operate with an output power no greater than 125 mW. The system shall hop to channel frequencies that are selected at the system hopping rate from a pseudo randomly ordered list of hopping frequencies. Each frequency must be used equally on the average by each transmitter. The system receivers shall have input bandwidths that match the hopping channel bandwidths of their corresponding transmitters and shall shift frequencies in synchronization with the transmitted signals.

TEST RESULTS

The pseudorandom frequency hopping sequence may be generated in a nine-stage shift register whose 5th and 9th stage outputs are added in a modulo-two addition stage. And the result is fed back to the input of the first stage. The sequence begins with the first one of 9 consecutive ones, for example: the shift register is initialized with nine ones.

- Number of shift register stages: 9
- Length of pseudo-random sequence: $2^9 - 1 = 511$ bits
- Longest sequence of zeros: 8 (non-inverted signal)

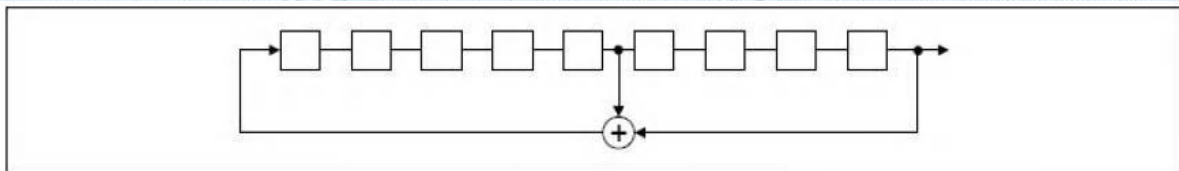

Linear Feedback Shift Register for Generation of the PRBS sequence

An example of pseudorandom frequency hopping sequence as follows:

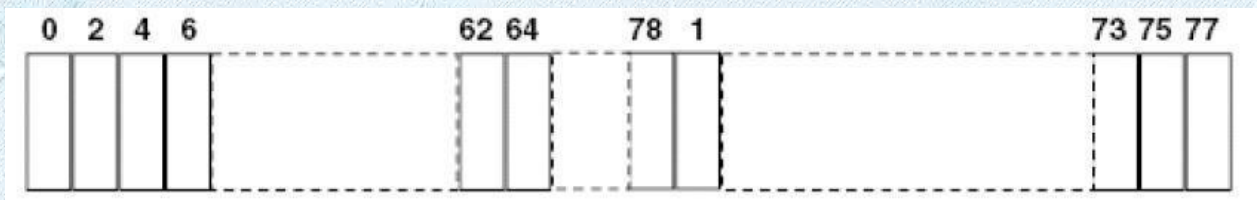

Each frequency used equally one the average by each transmitter.

The system receiver have input bandwidths that match the hopping channel bandwidths of their corresponding transmitter and shift frequencies in synchronization with the transmitted signals.

4.EUT TEST PHOTOS

Radiated Measurement (Below 1GHz)



Radiated Measurement (Above 1GHz)

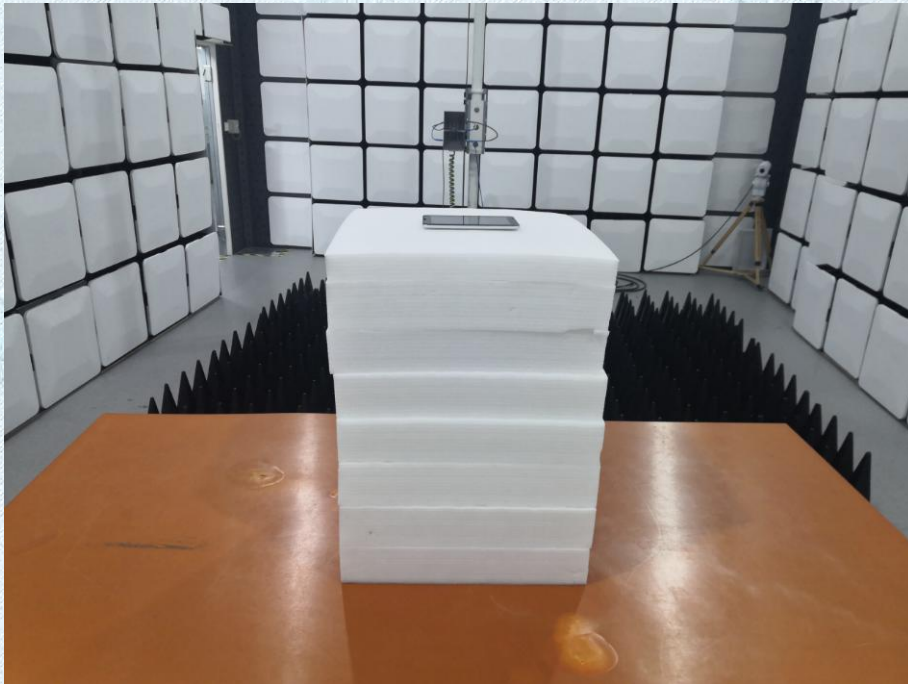

CONDUCTED EMISSION TEST SETUP

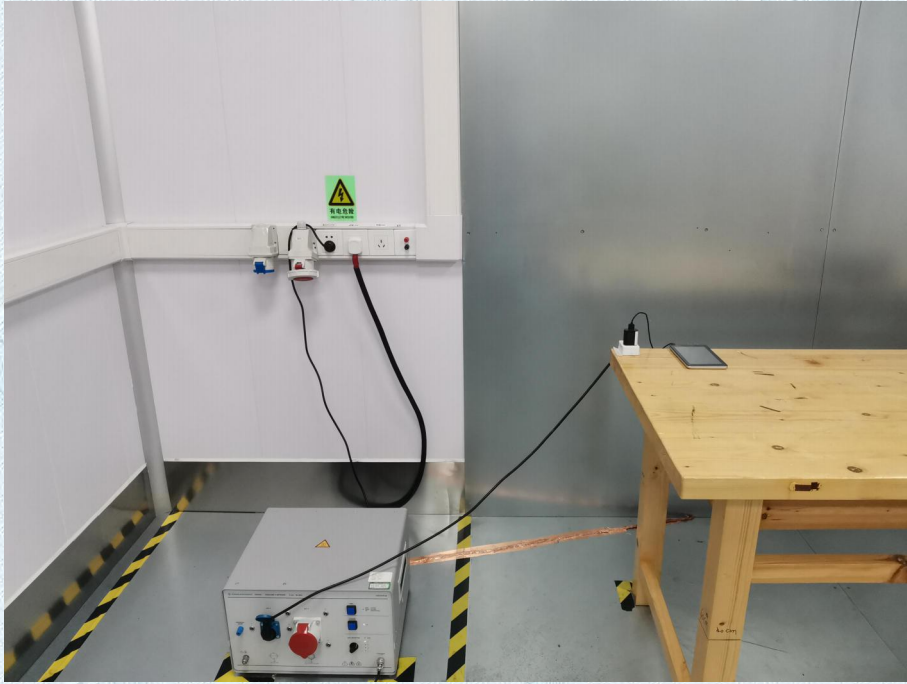

RF Conducted



5. PHOTOGRAPHS OF EUT CONSTRUCTIONAL

Please refer to Report No : KS2101S0424E01

*****THE END*****