

TABLE OF CONTENTS**Page**

1. TEST SUMMARY.....	3
1.1. TEST STANDARDS.....	3
1.2. REPORT VERSION.....	3
1.3. TEST DESCRIPTION.....	4
1.4. TEST FACILITY.....	5
1.5. MEASUREMENT UNCERTAINTY.....	6
1.6. ENVIRONMENTAL CONDITIONS.....	6
2. GENERAL INFORMATION.....	7
2.1. GENERAL DESCRIPTION OF EUT.....	7
2.2. OPERATION STATE.....	8
2.3. MEASUREMENT INSTRUMENTS LIST.....	9
2.5. TEST SOFTWARE.....	10
3. TEST ITEM AND RESULTS.....	11
3.1. ANTENNA REQUIREMENT.....	11
3.2. PEAK OUTPUT POWER.....	12
3.3. 20DB BANDWIDTH.....	19
3.4. CARRIER FREQUENCIES SEPARATION.....	32
3.5. NUMBER OF HOPPING CHANNEL.....	35
3.6. DWELL TIME.....	37
3.7. BAND EDGE AND SPURIOUS EMISSION (CONDUCTED).....	41
3.8. BAND EDGE EMISSIONS(RADIATED).....	47
3.9. RADIATED SPURIOUS EMISSIONS.....	52
3.10. CONDUCTED EMISSION.....	63
3.11. PSEUDORANDOM FREQUENCY HOPPING SEQUENCE.....	66
4. EUT TEST PHOTOS.....	67
5. PHOTOGRAPHS OF EUT CONSTRUCTIONAL.....	69

1. TEST SUMMARY

1.1. Test Standards

The tests were performed according to following standards:

FCC Rules Part 15.247: Operation within the bands of 902-928MHz, 2400-2483.5MHz, and 5725-5850MHz.

KDB 558074 D01 : The measurement guidance provided herein is applicable only to Digital Transmission System (DTS) devices operating in the 902-928 MHz. 2400-2483.5 MHz and/or 5725-5850 MHz bands under §15.247 of the FCC rules (Title 47 of the Code of Federal Regulations).

ANSI C63.10-2013: American National Standard for Testing Unlicensed Wireless Devices.

1.2. Report version

Revised No.	Date of issue	Description
01	Jan. 29, 2020	Original

1.3. Test Description

FCC Part 15 Subpart C(15.247)			
Test Item	Standard Section	Result	Test Engineer
	FCC		
Antenna Requirement	15.203	Pass	Rory Huang
Conducted Emission	15.207	Pass	Rory Huang
Restricted Bands	15.205	Pass	Rory Huang
Hopping Channel Separation	15.247(a)(1)	Pass	Rory Huang
Dwell Time	15.247(a)(1)	Pass	Rory Huang
Peak Output Power	15.247(b)(1)	Pass	Rory Huang
Number of Hopping Frequency	15.247 (a)(1)	Pass	Rory Huang
Band Edge Emissions	15.247(d)	Pass	Rory Huang
Radiated Spurious Emission	15.247(c)&15.209	Pass	Rory Huang
99% Occupied Bandwidth & 20dB Bandwidth	15.247(a)(1)	Pass	Rory Huang
Pseudorandom Frequency Hopping Sequence	15.247 (a)(1)	Pass	Rory Huang

Note: The measurement uncertainty is not included in the test result.

1.4. Test Facility

Address of the report laboratory

KSIGN(Guangdong) Testing Co., Ltd.

West Side of 1/F., Building C, Zone A, Fuyuan New Factory, Jiujiu Industrial Park, Minzhu, Shatou, Shajing, Bao'an District, Shenzhen, Guangdong, People's Republic of China

Laboratory accreditation

The test facility is recognized, certified, or accredited by the following organizations:

CNAS-Lab Code: L13261

KSIGN(Guangdong) Testing Co., Ltd. has been assessed and proved to be in Compliance with CNAS-CL01 Accreditation Criteria for Testing and Calibration Laboratories (identical to ISO/IEC17025: 2017 General Requirements) for the Competence of Testing and Calibration Laboratories.

A2LA-Lab Cert. No.: 5457.01

KSIGN(Guangdong) Testing Co., Ltd. EMC Laboratory has been accredited by A2LA for technical competence in the field of electrical testing, and proved to be in compliance with ISO/IEC 17025:2017 General Requirements for the Competence of Testing and Calibration Laboratories and any additional program requirements in the identified field of testing.

IC Registration No.: CN0096

The 3m alternate test site of KSIGN(Guangdong) Testing Co., Ltd. EMC Laboratory has been registered by Certification and Engineer Bureau of Industry Canada for the performance of with Registration NO.: CN0096

FCC-Registration No.: CN1272

KSIGN(Guangdong) Testing Co., Ltd. EMC Laboratory has been registered and fully described in a report filed with the (FCC) Federal Communications Commission. The acceptance letter from the FCC is maintained in our files.

1.5. Measurement Uncertainty

The data and results referenced in this document are true and accurate. The reader is cautioned that there may be errors within the calibration limits of the equipment and facilities. The measurement uncertainty was calculated for all measurements listed in this test report acc. to TR-100028-01” Electromagnetic compatibility and Radio spectrum Matters (ERM);Uncertainties in the measurement of mobile radio equipment characteristics; Part 1” and TR-100028-02 “Electromagnetic compatibility and Radio spectrum Matters (ERM);Uncertainties in the measurement of mobile radio equipment characteristics; Part 2 “ and is documented in the KSIGN(Guangdong) Testing Co., Ltd. system acc. to DIN EN ISO/IEC 17025. Furthermore, component and process variability of devices similar to that tested may result in additional deviation. The manufacturer has the sole responsibility of continued compliance of the device. Below is the best measurement capability for KSIGN(Guangdong) Testing Co., Ltd.

Test Items	Measurement Uncertainty	Notes
Transmitter power conducted	0.42 dB	(1)
Transmitter power Radiated	2.14 dB	(1)
Conducted spurious emissions 9kHz~40GHz	1.60 dB	(1)
Radiated spurious emissions 9kHz~40GHz	2.20 dB	(1)
Conducted Emissions 9kHz~30MHz	3.20 dB	(1)
Radiated Emissions 30~1000MHz	4.70 dB	(1)
Radiated Emissions 1~18GHz	5.00 dB	(1)
Radiated Emissions 18~40GHz	5.54 dB	(1)
Occupied Bandwidth	2.80 dB	(1)

Note (1): This uncertainty represents an expanded uncertainty expressed at approximately the 95% confidence level using a coverage factor of k=1.96.

1.6. Environmental conditions

During the measurement the environmental conditions were within the listed ranges:

Temperature:	15~35°C
Relative Humidity:	30~60 %
Air Pressure:	950~1050mba

2. GENERAL INFORMATION

2.1. General Description of EUT

Test Sample Number:	1-1-1(Normal Sample),1-1-2(Engineering Sample)
Product Name:	Tablet PC
Marketing Name:	/
Model/Type reference:	JZ708
Listed Model(s):	AMICUS-Prime,PowerPong-Omega , JZ807, JZ100
Model Difference:	The difference of product model only depends on the screen size, model name and appearance color vary according to market demand. Other power supply methods, safety structure and key components are the same, which do not affect the safety and electromagnetic compatibility performance.
Power supply(Adapter):	INPUT:100-240V~50/60Hz 0.3A Max OUTPUT:5V==2A
Power supply(Battery):	DC 3.7V 3000mAh 11.1Wh
Hardware version:	BND-MT8168-P863 V1.1
Software version:	V1.0
Bluetooth V4.1	
Modulation:	GFSK(DH5), π /4-DQPSK(2DH5), 8DPSK(3DH5)
Operation frequency:	2402MHz~2480MHz
Max Peak Output Power:	DH5: 6.33dBm 2DH5: 5.2dBm 3DH5: 5.01dBm
Channel number:	79
Channel separation:	1MHz
Antenna type:	PIFA Antenna
Antenna gain:	0.8dBi

2.2. Operation state

Operation Frequency List: The EUT has been tested under typical operating condition. The Applicant provides communication tools software to control the EUT for staying in continuous transmitting and receiving mode for testing. BT EDR, 79 channels are provided to the EUT. Channels 00/39/78 were selected for testing.

Operation Frequency List:

Channel	Frequency (MHz)
00	2402
01	2403
:	:
38	2440
39	2441
40	2442
:	:
77	2479
78	2480

Note: The display in grey were the channel selected for testing.

Test mode

For RF test items:
The engineering test program was provided and enabled to make EUT continuous transmit
For AC power line conducted emissions:
The EUT was set to connect with the Bluetooth instrument under large package sizes transmission.
For Radiated spurious emissions test item:
The engineering test program was provided and enabled to make EUT continuous transmit. The EUT in each of three orthogonal axis emissions had been tested, but only the worst case (X axis) data recorded in the report.

2.3. Measurement Instruments List

Tonscend JS0806-2 Test system					
Item	Test Equipment	Manufacturer	Model No.	Serial No.	Cal. Until
1	Spectrum Analyzer	R&S	FSV40-N	101798	04/07/2021
2	Vector Signal Generator	Agilent	N5182A	MY50142520	04/07/2021
3	Analog Signal Generator	HP	83752A	3344A00337	04/07/2021
4	Power Sensor	Agilent	E9304A	MY50390009	04/07/2021
5	Power Sensor	Agilent	E9300A	MY41498315	04/07/2021
6	Wideband Radio Communication Tester	R&S	CMW500	157282	04/07/2021
7	Climate Chamber	Angul	AGNH80L	1903042120	04/07/2021
8	Dual Output DC Power Supply	Agilent	E3646A	MY40009992	04/07/2021
9	RF Control Unit	Tonscend	JS0806-2	/	04/07/2021

Transmitter spurious emissions & Receiver spurious emissions					
Item	Test Equipment	Manufacturer	Model No.	Serial No.	Cal. Until
1	EMI Test Receiver	R&S	ESR	102525	04/07/2021
2	High Pass Filter	Chengdu E-Microwave	OHF-3-18-S	0E01901038	03/27/2021
3	High Pass Filter	Chengdu E-Microwave	OHF-6.5-18-S	0E01901039	03/27/2021
4	Spectrum Analyzer	HP	8593E	3831U02087	04/07/2021
5	Ultra-Broadband logarithmic period Antenna	Schwarzbeck	VULB 9163	01230	03/29/2023
6	Loop Antenna	Beijin ZHINAN	ZN30900C	18050	03/25/2021
7	Spectrum Analyzer	R&S	FSV40-N	101798	04/07/2021
8	Horn Antenna	Schwarzbeck	BBHA 9120 D	2023	03/29/2023
9	Pre-Amplifier	Schwarzbeck	BBV 9745	9745#129	04/07/2021
10	Pre-Amplifier	EMCI	EMC051835SE	980662	04/07/2021
11	Pre-Amplifier	Schwarzbeck	BBV-9721	57	04/07/2021
12	Horn Antenna	Schwarzbeck	BBHA 9170	00939	03/29/2021

Item	Test Equipment	Manufacturer	Model No.	Serial No.	Calibrated until
1	LISN	R&S	ENV432	1326.6105.02	03/27/2021
2	EMI Test Receiver	R&S	ESR	102524	04/07/2021
3	Manual RF Switch	JS TOYO	/	MSW-01/002	04/07/2021

Note:

- 1)The Cal. Interval was one year.
- 2)The cable loss has calculated in test result which connection between each test instruments.

2.5. Test Software

Software name	Model	Version
Conducted emission Measurement Software	EZ-EMC	EMC-Con 3A1.1
Radiated emission Measurement Software	EZ-EMC	FA-03A.2.RE
Bluetooth and WIFI Test System	JS1120-3	2.5.77.0418

3.2. Peak Output Power

Limit

Test Item	Limit	Frequency Range(MHz)
Peak Output Power	Hopping Channels>75 Power<1W(30dBm) Other <125mW(21dBm)	2400~2483.5

Test Configuration

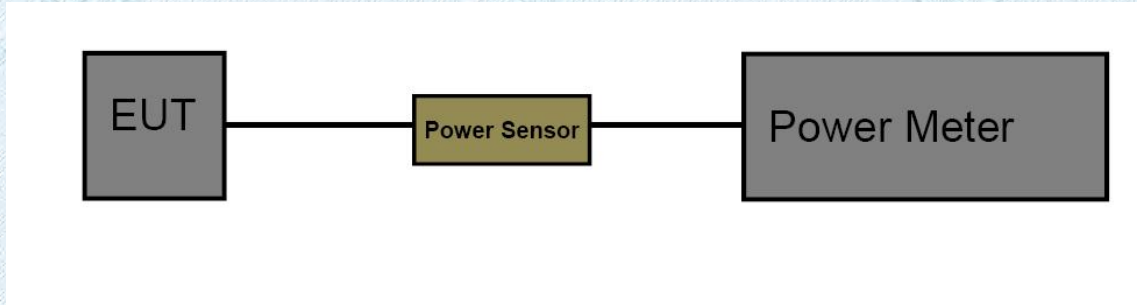

Test Procedure

1. Connect EUT RF output port to the Spectrum Analyzer through an RF attenuator.
2. Spectrum Setting:
Peak Detector: RBW=1 MHz, VBW=3 MHz for bandwidth less than 1MHz.
RBW=3 MHz, VBW=10 MHz for bandwidth more than 1MHz.

Test Mode

Please refer to the clause 2.3

Test Result

Test Mode:	DH5		
Channel frequency (MHz)	Test Result (dBm)	Limit (dBm)	
2402	6.04	30	
2441	6.33		
2480	5.63		

2402 MHz

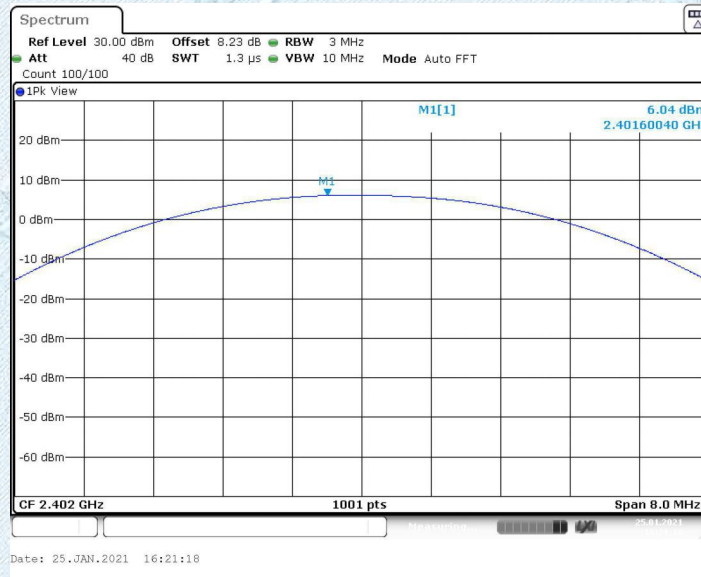

2441 MHz



Date: 25.JAN.2021 16:25:49

2480 MHz

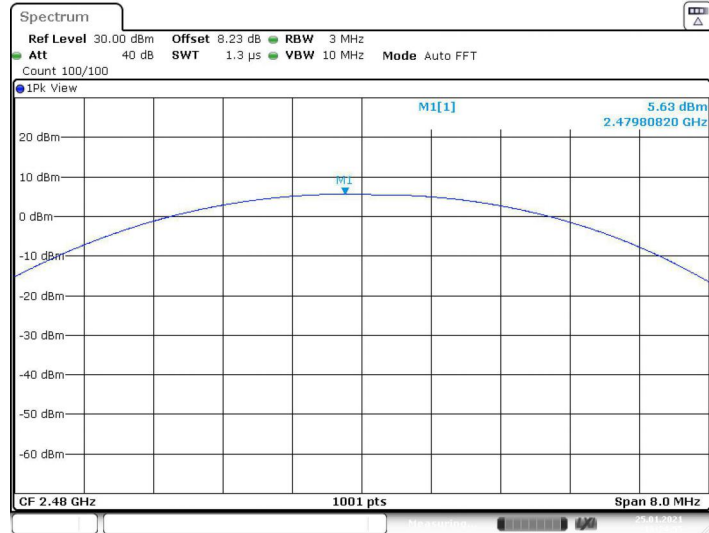

Date: 25.JAN.2021 16:24:56

Test Mode:	2DH5	
Channel frequency (MHz)	Test Result (dBm)	Limit (dBm)
2402	5.2	30
2441	5.09	
2480	4.53	

2402 MHz

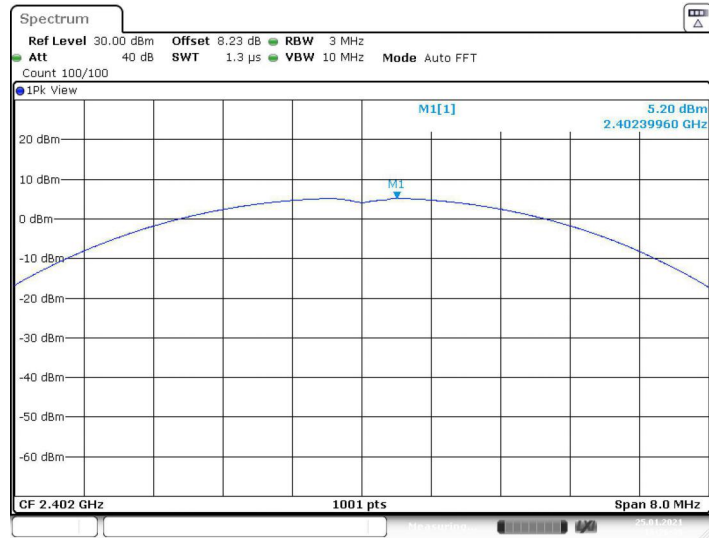

Date: 25.JAN.2021 16:26:39

2441 MHz

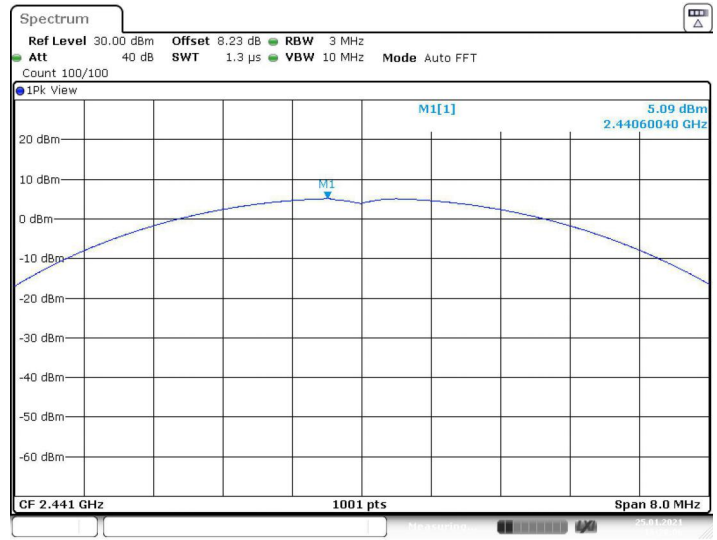

Date: 25.JAN.2021 16:28:06

2480 MHz

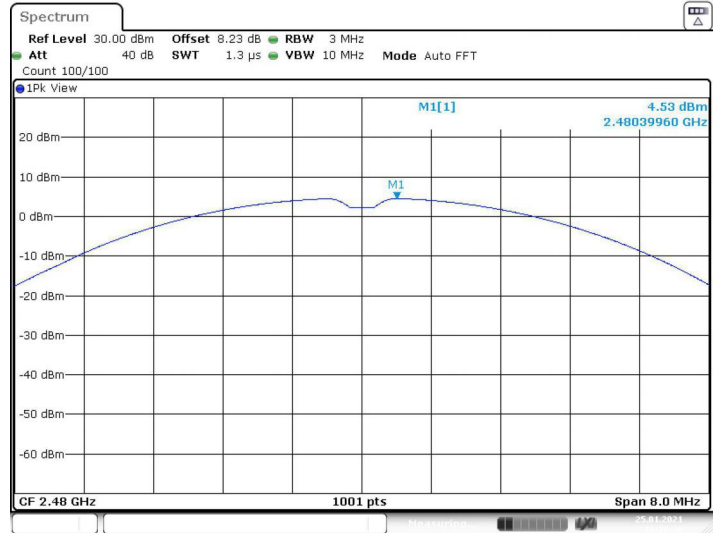

Date: 25.JAN.2021 16:28:36

Test Mode:	3DH5	
Channel frequency (MHz)	Test Result (dBm)	Limit (dBm)
2402	4.81	30
2441	5.01	
2480	4.86	

2402 MHz



Date: 25.JAN.2021 16:29:47

2441 MHz

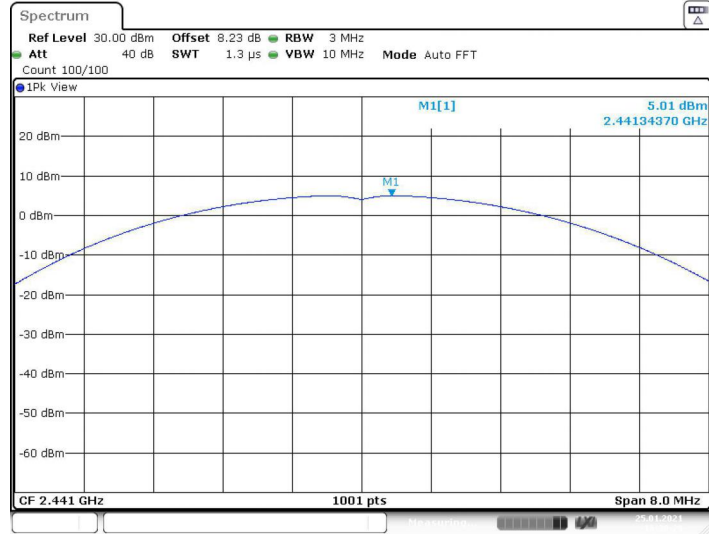

2480 MHz

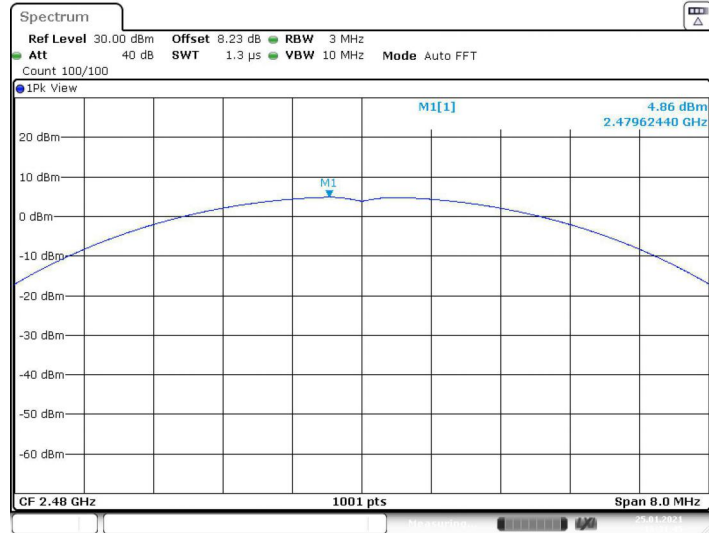

3.3. 20dB Bandwidth

Limit

Test Item	Limit	Frequency Range(MHz)
Bandwidth	N/A	2400~2483.5

Test Configuration

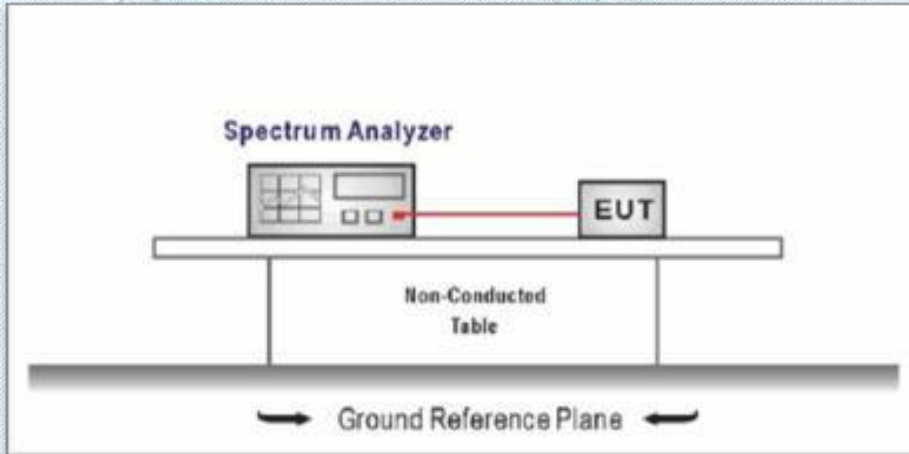

Test Procedure

1. Connect EUT RF output port to the Spectrum Analyzer through an RF attenuator.
2. Spectrum Setting:
 - (1) Set RBW = 30 kHz.
 - (2) Set the video bandwidth (VBW) $\geq 3 \times$ RBW.
 - (3) Detector = Peak.
 - (4) Trace mode = Max hold.
 - (5) Sweep = Auto couple.

NOTE: The EUT was set to continuously transmitting in each mode and low, Middle and high channel for the test.

Test Mode

Please refer to the clause 2.3.

Test Results

Test Mode:	DH5			
Channel frequency (MHz)	20dB Bandwidth [MHz]	FL[MHz]	FH[MHz]	Verdict
2402	0.810	2401.559	2402.369	PASS
2441	0.810	2440.559	2441.369	PASS
2480	0.807	2479.559	2480.366	PASS

2402 MHz



2441 MHz



2480 MHz

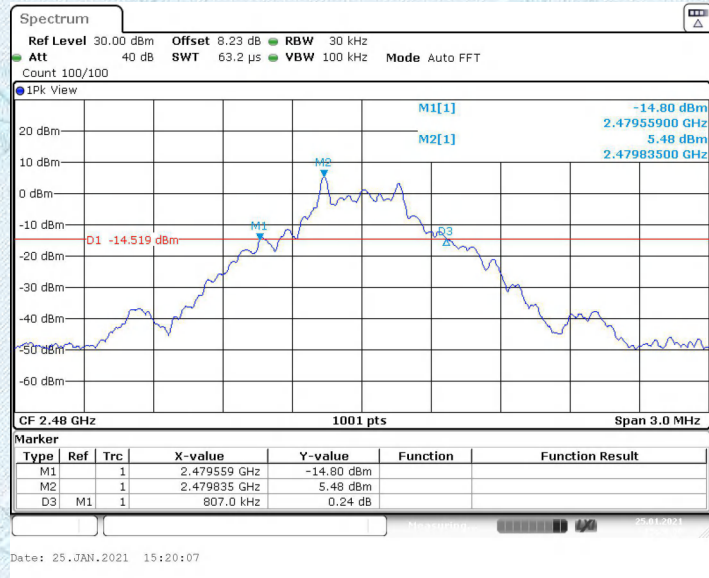

Test Mode:	2DH5			
Channel frequency (MHz)	20dB Bandwidth [MHz]	FL[MHz]	FH[MHz]	Verdict
2402	1.122	2401.427	2402.549	PASS
2441	1.122	2440.427	2441.549	PASS
2480	1.122	2479.427	2480.549	PASS

2402 MHz

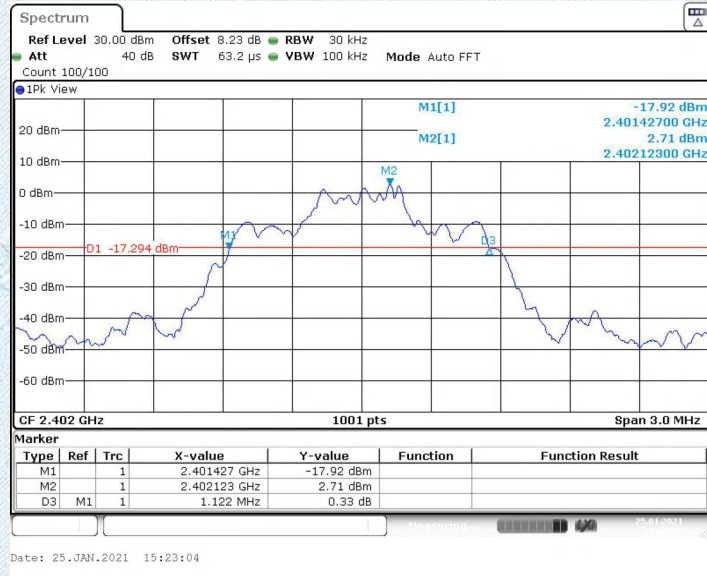

2441 MHz

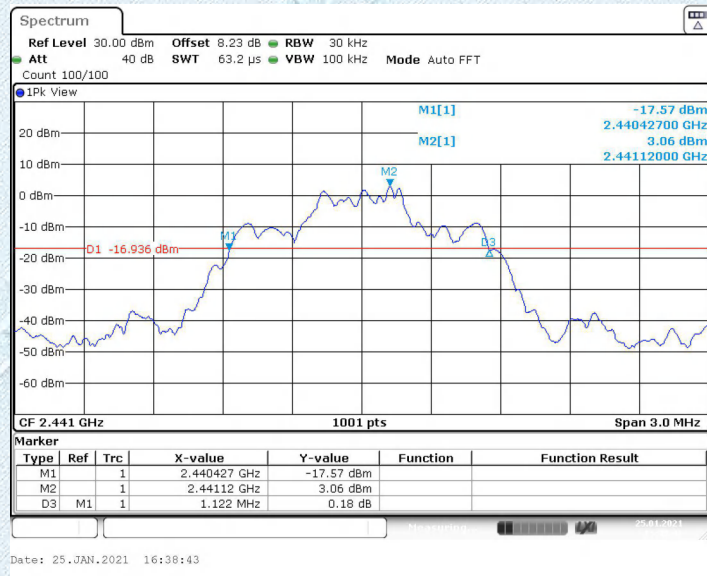

2480 MHz



Test Mode:	3DH5			
Channel frequency (MHz)	20dB Bandwidth [MHz]	FL[MHz]	FH[MHz]	Verdict
2402	1.113	2401.433	2402.546	PASS
2441	1.116	2440.433	2441.549	PASS
2480	1.113	2479.433	2480.546	PASS

2402 MHz

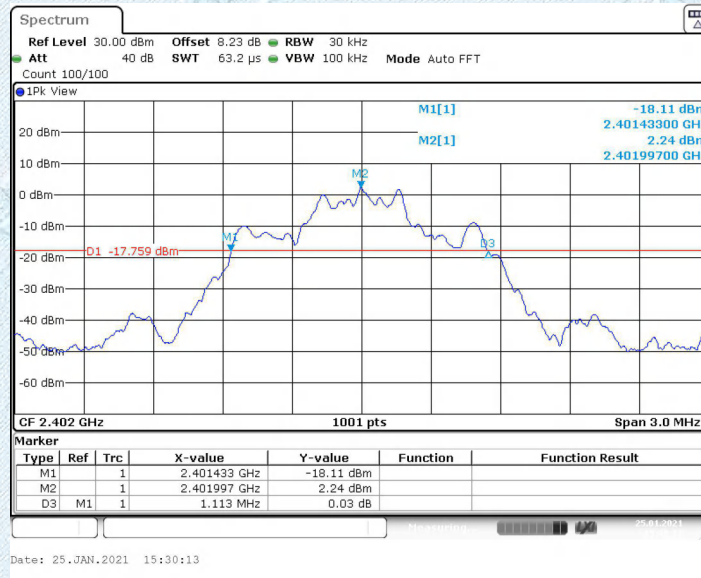

2441 MHz



2480 MHz

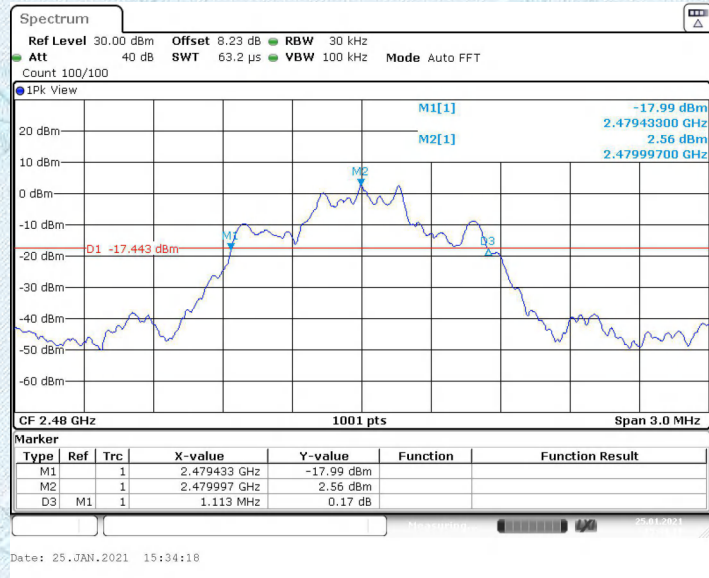

Test Mode:	DH5			
Channel frequency (MHz)	99% OCB [MHz]	FL[MHz]	FH[MHz]	Verdict
2402	0.863	2401.562	2402.426	PASS
2441	0.863	2440.562	2441.426	PASS
2480	0.86	2479.565	2480.426	PASS

2402 MHz



2441 MHz

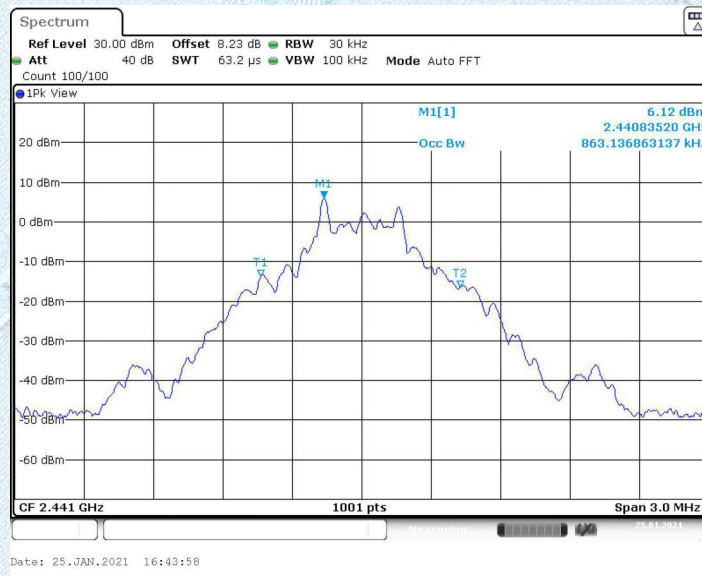

2480 MHz

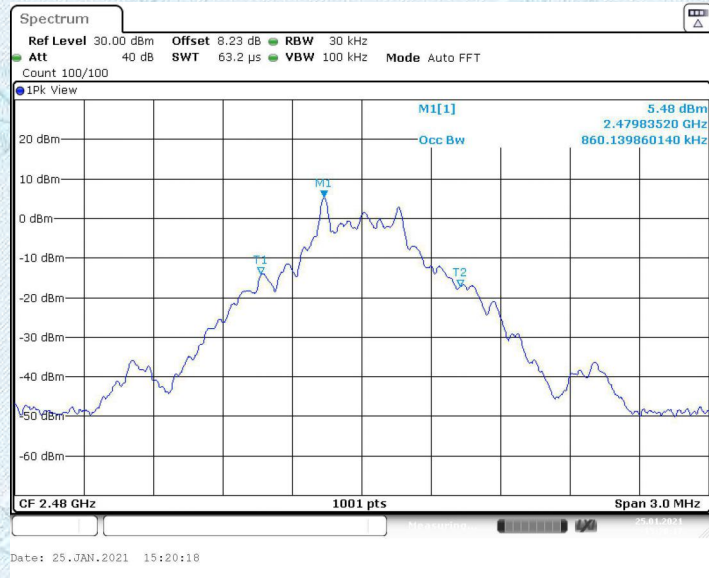

Test Mode:	2DH5			
Channel frequency (MHz)	99% OCB [MHz]	FL[MHz]	FH[MHz]	Verdict
2402	1.064	2401.464	2402.527	PASS
2441	1.064	2440.464	2441.527	PASS
2480	1.064	2479.464	2480.527	PASS

2402 MHz

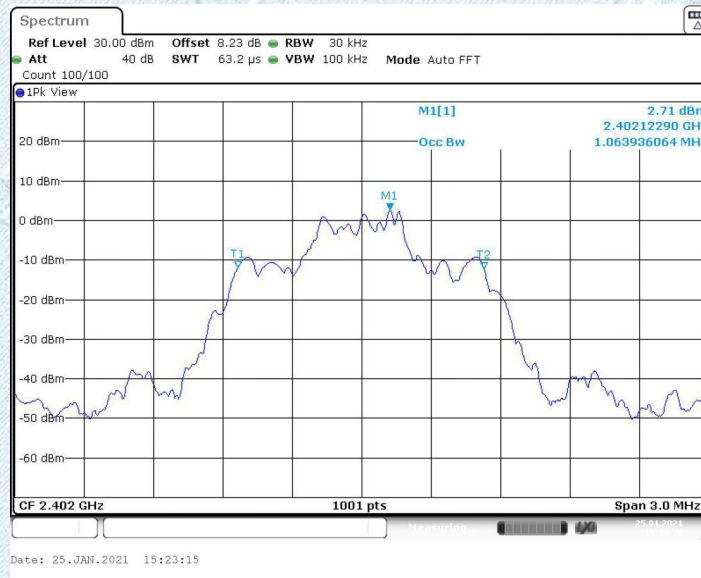

2441 MHz

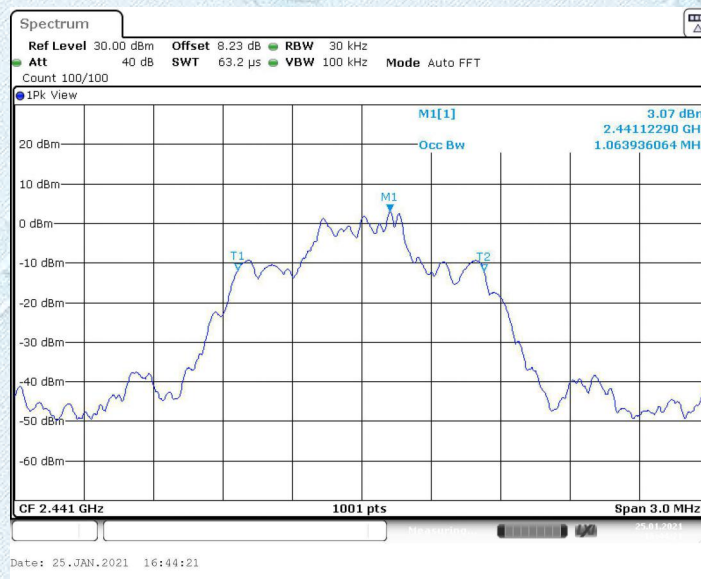

2480 MHz

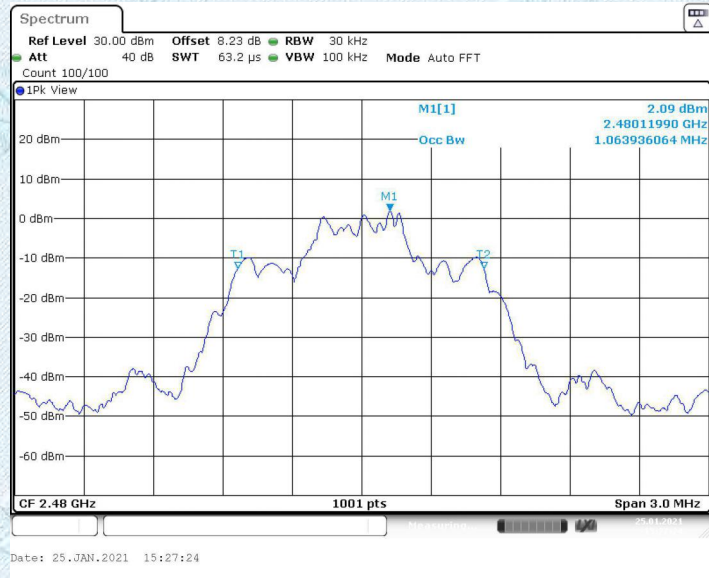

Test Mode:	3DH5			
Channel frequency (MHz)	99% OCB [MHz]	FL[MHz]	FH[MHz]	Verdict
2402	1.055	2401.464	2402.518	PASS
2441	1.055	2440.464	2441.518	PASS
2480	1.055	2479.464	2480.518	PASS

2402 MHz

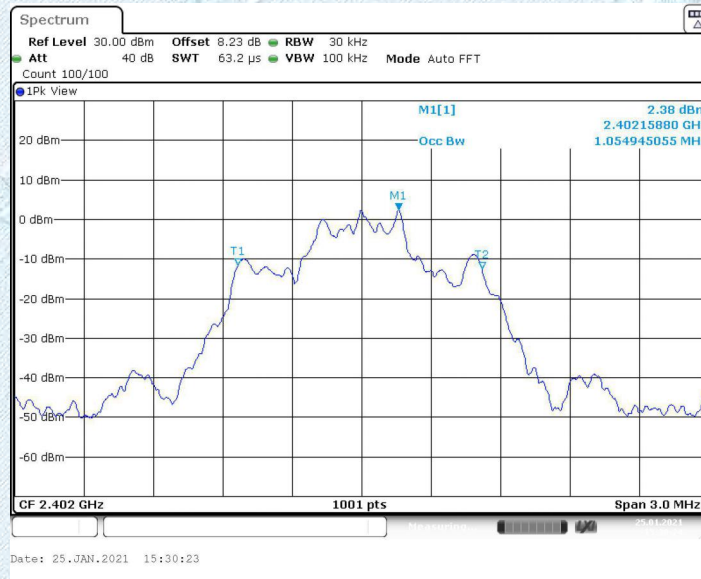

2441 MHz



2480 MHz

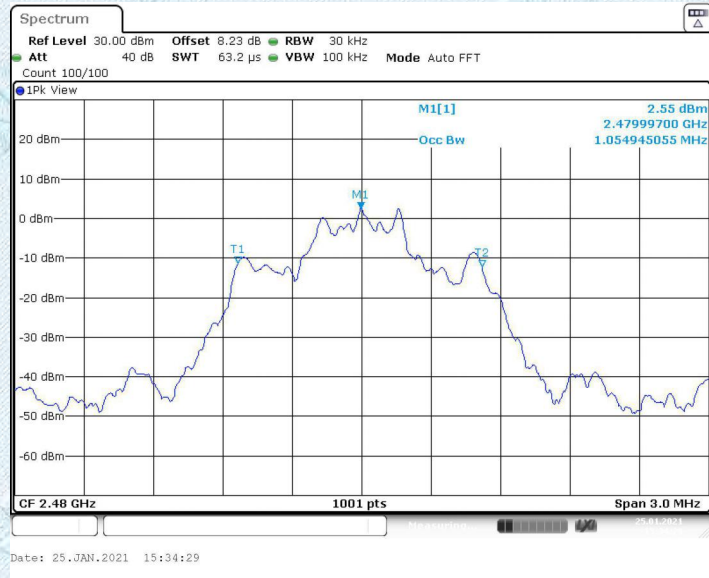

3.4. Carrier Frequencies Separation

LIMIT

FCC CFR Title 47 Part 15 Subpart C Section 15.247 (a)(1):

frequency hopping systems shall have hopping channel carrier frequencies separated by minimum of 25kHz or the $\frac{2}{3} \times 20\text{dB}$ bandwidth of the hopping channel, whichever is greater.

Test Item	Limit	Frequency Range(MHz)
Channel Separation	>25KHz or >two-thirds of the 20 dB bandwidth Which is greater	2400~2483.5

Test Configuration

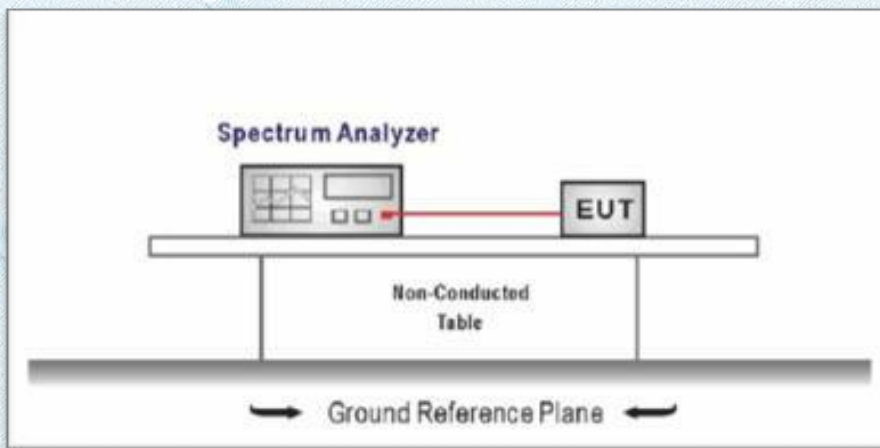

Test Procedure

1. Connect EUT RF output port to the Spectrum Analyzer through an RF attenuator.

2. Spectrum Setting:

- (1) Set RBW = 100 kHz.
- (2) Set the video bandwidth (VBW) ≥ 3 RBW.
- (3) Detector = Peak.
- (4) Trace mode = Max hold.
- (5) Sweep = Auto couple.

NOTE: The EUT was set to continuously transmitting in each mode and low, Middle and high channel for the test.

Test Mode

Please refer to the clause 2.3.

Test Results

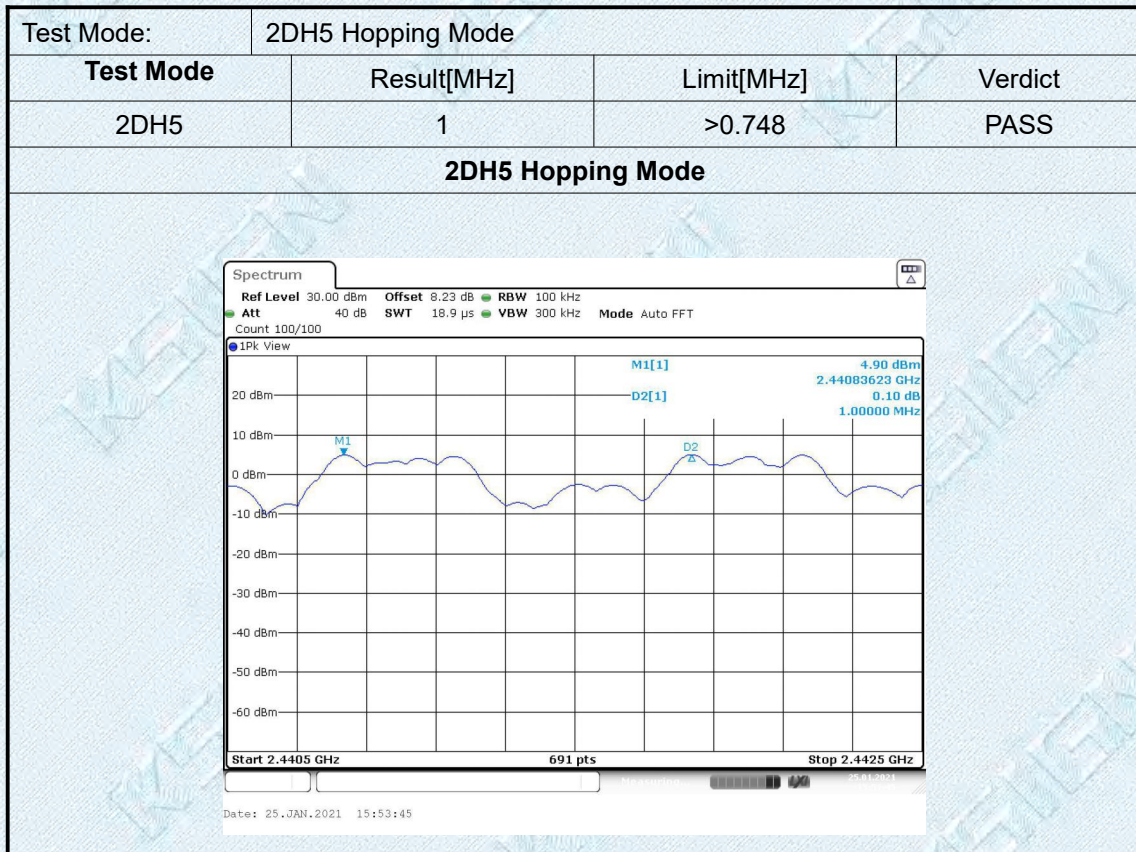
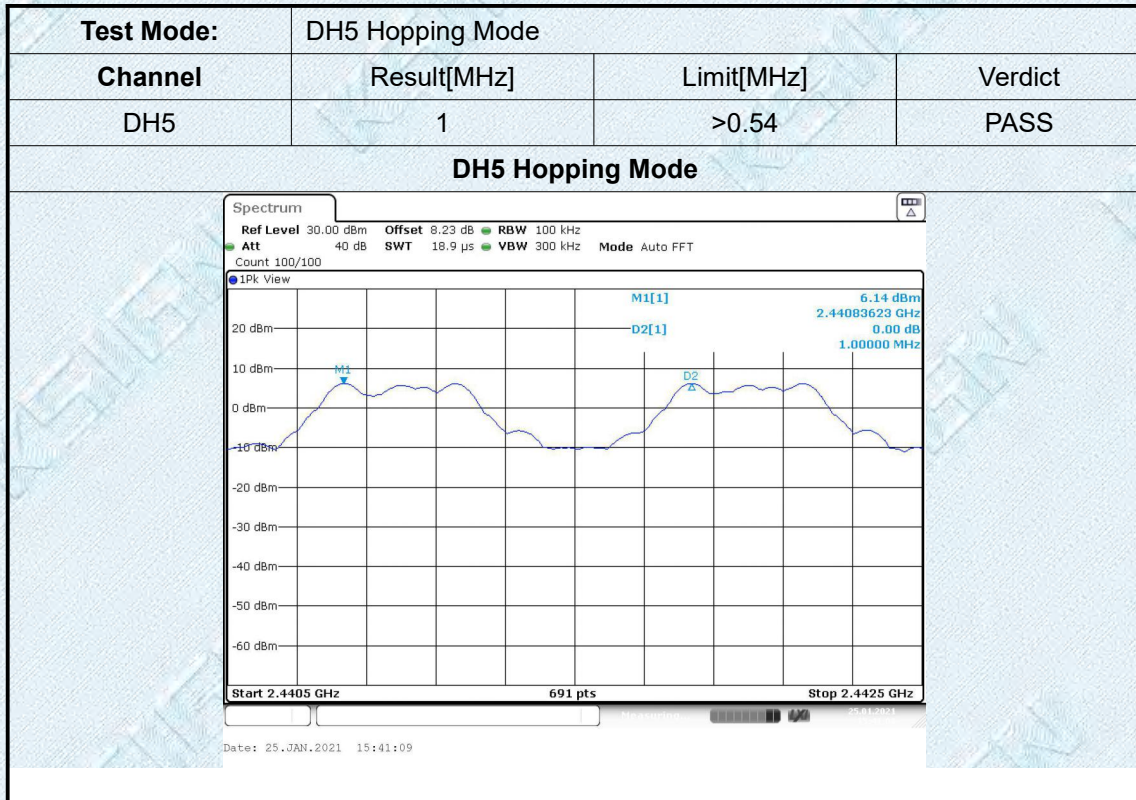

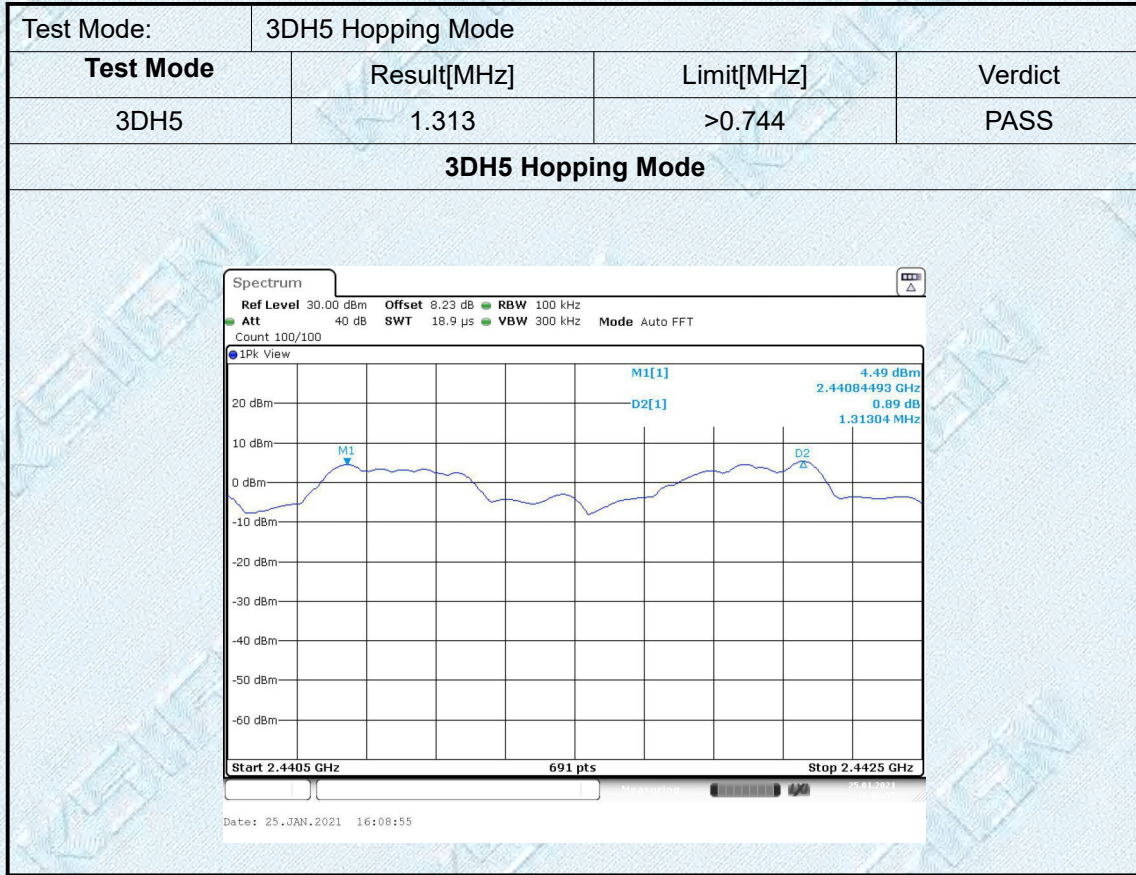

3.5. Number of Hopping Channel

Limit

Section	Test Item	Limit
15.247	Number of Hopping Channel	>15

Test Configuration

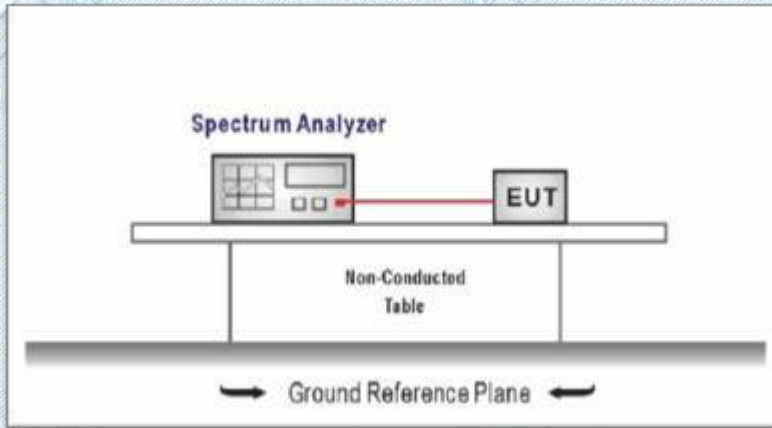

Test Procedure

1. Connect EUT RF output port to the Spectrum Analyzer through an RF attenuator.
2. Spectrum Setting:
 - (1) Peak Detector: RBW=100 kHz, VBW ≥ RBW, Sweep time= Auto.

Test Mode

Please refer to the clause 2.3.

Test Result