

FCC ID: 2AKZA-QCA9377
Report No.: T180627D11-RP4

Page: 1 / 185
Rev: 02

RADIO TEST REPORT

FCC 47 CFR PART 15 SUBPART E

Test Standard	FCC Part 15.407
Brand name	TechNexion
Applicant	TechNexion Ltd.
Product name	WiFi+Bluetooth 4.1(HS) System on Module
Model No.	PIXI-9377
Test Result	Pass

The test Result was tested by Compliance Certification Services Inc. The test data, data evaluation, test procedures, and equipment configurations shown in this report were given in ANSI C63.10: 2013 and compliance standards.

The test results of this report relate only to the tested sample (EUT) identified in this report.

The test Report of full or partial shall not copy. Without written approval of Compliance Certification Services Inc. (Wugu Laboratory)

Approved by:

Reviewed by:

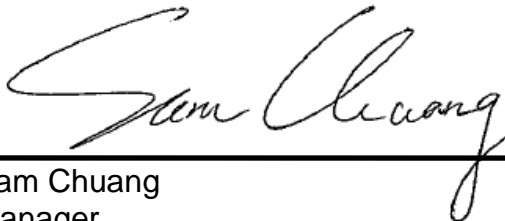

Sam Chuang
Manager



Jerry Chuang
Engineer

Unless otherwise stated the results shown in this test report refer only to the sample(s) tested and such sample(s) are retained for 90 days only.
除非另有說明，此報告結果僅對測試之樣品負責，同時此樣品僅保留90天。本報告未經本公司書面許可，不可部分複製。

This document is issued by the Company subject to its General Conditions of Service printed overleaf, available on request or accessible at www.sgs.com/terms_and_conditions.htm and for electronic format documents, subject to Terms and Conditions for Electronic Documents at www.sgs.com/terms_e-document.htm. Attention is drawn to the limitation of liability, indemnification and jurisdiction issues defined therein. Any holder of this document is advised that information contained hereon reflects the Company's findings at the time of its intervention only and within the limits of Client's instructions, if any. The Company's sole responsibility is to its Client and this document does not exonerate parties to a transaction from exercising all their rights and obligations under the transaction documents. This document cannot be reproduced except in full, without prior written approval of the Company. Any unauthorized alteration, forgery or falsification of the content or appearance of this document is unlawful and offenders may be prosecuted to the fullest extent of the law.

Revision History

Rev.	Issue Date	Revisions	Effect Page	Revised By
00	August 28, 2018	Initial Issue	ALL	May Lin
01	September 20, 2018	<ol style="list-style-type: none"> 1. Revised EUT information 、 antenna information and test summary. 2. Remove "For PIFA Antenna". 3. Update KDB 937606 to KDB 414788. 4. Revised the test data and test result. 5. Modify the test mode frequency. 	P.5, P.9, P.13, P.34-35 P.48, P.61, P.95, P.131-132, P.167-168, P.184-185	May Lin
02	September 27, 2018	<ol style="list-style-type: none"> 1. Revised the worst mode of measurement. 	P.11	May Lin

Table of contents

1. GENERAL INFORMATION	4
1.1 EUT INFORMATION	4
1.2 EUT CHANNEL INFORMATION	5
1.3 ANTENNA INFORMATION	5
1.4 MEASUREMENT UNCERTAINTY	6
1.5 FACILITIES AND TEST LOCATION	6
1.6 INSTRUMENT CALIBRATION	7
1.7 SUPPORT AND EUT ACCESSORIES EQUIPMENT	8
1.8 TEST METHODOLOGY AND APPLIED STANDARDS	8
2. TEST SUMMERY	9
3. DESCRIPTION OF TEST MODES	10
3.1 THE WORST MODE OF OPERATING CONDITION	10
3.2 THE WORST MODE OF MEASUREMENT	11
3.3 EUT DUTY CYCLE	13
4. TEST RESULT	14
4.1 AC POWER LINE CONDUCTED EMISSION	14
4.2 26dB BANDWIDTH, 6dB BANDWIDTH AND OCCUPIED BANDWIDTH (99%)	17
4.3 OUTPUT POWER MEASUREMENT	32
4.4 POWER SPECTRAL DENSITY	36
4.5 RADIATION BANDEDGE AND SPURIOUS EMISSION	47
4.6 FREQUENCY STABILITY	183
APPENDIX 1 - PHOTOGRAPHS OF EUT	

1. GENERAL INFORMATION

1.1 EUT INFORMATION

Applicant	TechNexion Ltd. 16f-5, No.736, Zhongzheng Road, Zhonghe Dist., New Taipei City, 23511 Taiwan ROC																																
Manufacturer	TechNexion Ltd. 16f-5, No.736, Zhongzheng Road, Zhonghe Dist., New Taipei City, 23511 Taiwan ROC																																
Equipment	WiFi+Bluetooth 4.1(HS) System on Module																																
Model Name	PIXI-9377																																
Model Discrepancy	N/A																																
Received Date	June 27, 2018																																
Date of Test	July 13 ~ August 8, 2018																																
Power Supply	Power by host system																																
HW Version	A1																																
FW Version	A1																																
Output Power(W)	<table border="1"> <thead> <tr> <th>Band</th> <th>Mode</th> <th>Frequency Range (MHz)</th> <th>Output Power (W)</th> </tr> </thead> <tbody> <tr> <td rowspan="4">U-NII-1</td> <td>IEEE 802.11a</td> <td>5180 ~ 5240</td> <td>0.0236</td> </tr> <tr> <td>IEEE 802.11n HT 20 MHz</td> <td>5180 ~ 5240</td> <td>0.0236</td> </tr> <tr> <td>IEEE 802.11n HT 40 MHz</td> <td>5190 ~ 5230</td> <td>0.0447</td> </tr> <tr> <td>IEEE 802.11ac VHT 80 MHz</td> <td>5210</td> <td>0.0048</td> </tr> <tr> <td rowspan="4">U-NII-3</td> <td>IEEE 802.11a</td> <td>5745 ~ 5825</td> <td>0.0187</td> </tr> <tr> <td>IEEE 802.11n HT 20 MHz</td> <td>5745 ~ 5825</td> <td>0.0209</td> </tr> <tr> <td>IEEE 802.11n HT 40 MHz</td> <td>5755 ~ 5795</td> <td>0.0378</td> </tr> <tr> <td>IEEE 802.11ac VHT 80 MHz</td> <td>5775</td> <td>0.0187</td> </tr> </tbody> </table>			Band	Mode	Frequency Range (MHz)	Output Power (W)	U-NII-1	IEEE 802.11a	5180 ~ 5240	0.0236	IEEE 802.11n HT 20 MHz	5180 ~ 5240	0.0236	IEEE 802.11n HT 40 MHz	5190 ~ 5230	0.0447	IEEE 802.11ac VHT 80 MHz	5210	0.0048	U-NII-3	IEEE 802.11a	5745 ~ 5825	0.0187	IEEE 802.11n HT 20 MHz	5745 ~ 5825	0.0209	IEEE 802.11n HT 40 MHz	5755 ~ 5795	0.0378	IEEE 802.11ac VHT 80 MHz	5775	0.0187
Band	Mode	Frequency Range (MHz)	Output Power (W)																														
U-NII-1	IEEE 802.11a	5180 ~ 5240	0.0236																														
	IEEE 802.11n HT 20 MHz	5180 ~ 5240	0.0236																														
	IEEE 802.11n HT 40 MHz	5190 ~ 5230	0.0447																														
	IEEE 802.11ac VHT 80 MHz	5210	0.0048																														
U-NII-3	IEEE 802.11a	5745 ~ 5825	0.0187																														
	IEEE 802.11n HT 20 MHz	5745 ~ 5825	0.0209																														
	IEEE 802.11n HT 40 MHz	5755 ~ 5795	0.0378																														
	IEEE 802.11ac VHT 80 MHz	5775	0.0187																														

Report No.: T180627D11-RP4

1.2 EUT CHANNEL INFORMATION

Frequency Range	UNII-1	
	IEEE 802.11a	5180 ~ 5240 MHz
	IEEE 802.11n HT 20 MHz	5180 ~ 5240 MHz
	IEEE 802.11n HT 40 MHz	5190 ~ 5230 MHz
	IEEE 802.11ac VHT 80 MHz	5210 MHz
	UNII-3	
	IEEE 802.11a	5745 ~ 5825 MHz
	IEEE 802.11n HT 20 MHz	5745 ~ 5825 MHz
	IEEE 802.11n HT 40 MHz	5755 ~ 5795 MHz
	IEEE 802.11ac VHT 80 MHz	5775 MHz
Modulation Type	1. IEEE 802.11a mode: OFDM 2. IEEE 802.11n HT 20 MHz mode: OFDM 3. IEEE 802.11n HT 40 MHz mode: OFDM 4. IEEE 802.11ac VHT 80 MHz mode: OFDM	

Remark:

Refer as ANSI 63.10:2013 clause 5.6.1 Table 4 for test channels

Number of frequencies to be tested		
Frequency range in which device operates	Number of frequencies	Location in frequency range of operation
<input type="checkbox"/> 1 MHz or less	1	Middle
<input type="checkbox"/> 1 MHz to 10 MHz	2	1 near top and 1 near bottom
<input checked="" type="checkbox"/> More than 10 MHz	3	1 near top, 1 near middle, and 1 near bottom

1.3 ANTENNA INFORMATION

Antenna Type	<input checked="" type="checkbox"/> PIFA <input type="checkbox"/> PCB <input checked="" type="checkbox"/> Dipole <input type="checkbox"/> Coils					
Antenna Gain		Brand	P/N	Type	Peak Gain	Worst Mode
	Antenna 1	TechNexion	VM2450-25523-OOX-180	PIFA	3dBi	X
	Antenna 2	TechNexion	VM2450-ASSY1005	Dipole	6dBi	O

1.4 MEASUREMENT UNCERTAINTY

PARAMETER	UNCERTAINTY
AC Powerline Conducted Emission	+/- 1.2575
Emission bandwidth, 20dB bandwidth	+/- 1.4003
RF output power, conducted	+/- 1.1372
Power density, conducted	+/- 1.4003
3M Semi Anechoic Chamber / 30M~200M	+/- 4.0138
3M Semi Anechoic Chamber / 200M~1000M	+/- 3.9483
3M Semi Anechoic Chamber / 1G~8G	+/- 2.5975
3M Semi Anechoic Chamber / 8G~18G	+/- 2.6112
3M Semi Anechoic Chamber / 18G~26G	+/- 2.7389
3M Semi Anechoic Chamber / 26G~40G	+/- 2.9683

Remark:

1. This uncertainty represents an expanded uncertainty expressed at approximately the 95% confidence level using a coverage factor of $k=2$
2. ISO/IEC 17025 requires that an estimate of the measurement uncertainties associated with the emissions test results be included in the report.

1.5 FACILITIES AND TEST LOCATION

All measurement facilities used to collect the measurement data are located at

No.11, Wugong 6th Rd., Wugu Dist., New Taipei City 24891, Taiwan. (R.O.C.)

Test site	Test Engineer	Remark
AC Conduction Room	Dally Hong	-
Radiation	Jerry Chuang	-
RF Conducted	Jerry Chuang	-

Remark: The sites are constructed in conformance with the requirements of ANSI C63.7, ANSI C63.4 and CISPR Publication 22.

1.6 INSTRUMENT CALIBRATION

RF Conducted Test Site					
Equipment	Manufacturer	Model	S/N	Cal Date	Cal Due
Cable	HUBER SUHNER	SUCOFLEX 104PEA	25157	06/29/2018	06/28/2019
Power Meter	Anritsu	ML2495A	1012009	09/18/2017	09/17/2018
Power Sensor	Anritsu	MA2411B	1126148	02/06/2018	02/05/2019
Signal Analyzer	R&S	FSV 40	101073	10/02/2017	10/01/2018

3M 966 Chamber Test Site					
Equipment	Manufacturer	Model	S/N	Cal Date	Cal Due
Bilog Antenna	Sunol Sciences	JB3	A030105	07/13/2018	07/12/2019
Cable	HUBER SUHNER	SUCOFLEX 104PEA	25157	07/31/2017	07/30/2018
Cable	HUBER SUHNER	SUCOFLEX 104PEA	20995	07/31/2017	07/30/2018
Digital Thermo-Hygro Meter	WISEWIND	1206	D07	02/08/2018	02/07/2019
Double Ridged Guide Horn Antenna	ETC	MCTD 1209	DRH13M02003	08/25/2017	08/24/2018
High Pass Filters	MICRO TRONICS	HPM13195	003	05/14/2018	05/13/2019
Horn Antenna	ETS LINDGREN	3116	00026370	01/04/2018	01/03/2019
Loop Ant	COM-POWER	AL-130	121051	03/21/2018	03/20/2019
Pre-Amplifier	EMEC	EM330	060609	06/29/2018	06/28/2019
Pre-Amplifier	MITEQ	AMF-6F-260400-40-8P	985646	06/21/2018	06/20/2019
Pre-Amplifier	HP	8449B	3008A00965	06/29/2018	06/28/2019
PSA Series Spectrum Analyzer	Agilent	E4446A	MY46180323	05/31/2018	05/30/2019
Antenna Tower	CCS	CC-A-1F	N/A	N.C.R	N.C.R
Controller	CCS	CC-C-1F	N/A	N.C.R	N.C.R
Turn Table	CCS	CC-T-1F	N/A	N.C.R	N.C.R

AC Conducted Emissions Test Site					
Equipment	Manufacturer	Model	S/N	Cal Date	Cal Due
LISN	R&S	ENV216	101054	02/06/2018	02/05/2019
LISN	SCHWARZBECK	NSLK 8127	8127-541	02/09/2018	02/08/2019
EMI Test Receiver	R&S	ESCI	101203	11/02/2017	11/01/2018
CABLE	EMCI	CFD300-NL	CERF	07/03/2018	07/02/2019

Remark: Each piece of equipment is scheduled for calibration once a year.

1.7 SUPPORT AND EUT ACCESSORIES EQUIPMENT

EUT Accessories Equipment					
No.	Equipment	Brand	Model	Series No.	FCC ID
	N/A				

Support Equipment					
No.	Equipment	Brand	Model	Series No.	FCC ID
1	NB(K)	Toshiba	voyager	ZD 154034s	N/A
2	NB	Lenovo	TP00056A	R33B65	PD97260HU

1.8 TEST METHODOLOGY AND APPLIED STANDARDS

The test methodology, setups and results comply with all requirements in accordance with ANSI C63.10:2013, FCC Part 2, FCC Part 15.407, KDB 789033 D02.

2. TEST SUMMERY

FCC Standard Sec.	Chapter	Test Item	Result
15.203	1.3	Antenna Requirement	Pass
15.207	4.1	AC Conducted Emission	Pass
15.403(i)	4.2	26dB Bandwidth	Pass
15.407(e)	4.2	6dB Bandwidth	Pass
2.1049	4.2	Occupied Bandwidth (99%)	Pass
15.407(a)	4.3	Output Power Measurement	Pass
15.407(a)	4.4	Power Spectral Density	Pass
15.407(b)	4.5	Radiation Band Edge	Pass
15.407(b)	4.5	Radiation Spurious Emission	Pass
15.407(g)	4.6	Frequency Stability	Pass

3. DESCRIPTION OF TEST MODES

3.1 THE WORST MODE OF OPERATING CONDITION

<p>Operation mode</p>	<p>1. IEEE 802.11a mode: 6Mbps 2. IEEE 802.11n HT 20 MHz mode: MCS0 3. IEEE 802.11n HT 40 MHz mode: MCS0 4. IEEE 802.11ac VHT 80 MHz mode: MCS0</p>																														
<p>Operating Frequency Range & Number of Channels</p>	<table border="1"> <thead> <tr> <th></th> <th>Mode</th> <th>Frequency Range (MHz)</th> <th>Number of Channels</th> </tr> </thead> <tbody> <tr> <td rowspan="4">U-NII-1</td> <td>IEEE 802.11a</td> <td>5180 ~ 5240</td> <td>4 Channels</td> </tr> <tr> <td>IEEE 802.11n HT 20 MHz</td> <td>5180 ~ 5240</td> <td>4 Channels</td> </tr> <tr> <td>IEEE 802.11n HT 40 MHz</td> <td>5190 ~ 5230</td> <td>2 Channels</td> </tr> <tr> <td>IEEE 802.11ac VHT 80 MHz</td> <td>5210</td> <td>1 Channels</td> </tr> <tr> <td rowspan="4">U-NII-3</td> <td>IEEE 802.11a</td> <td>5745 ~ 5825</td> <td>5 Channels</td> </tr> <tr> <td>IEEE 802.11n HT 20 MHz</td> <td>5745 ~ 5825</td> <td>5 Channels</td> </tr> <tr> <td>IEEE 802.11n HT 40 MHz</td> <td>5755 ~ 5795</td> <td>2 Channels</td> </tr> <tr> <td>IEEE 802.11ac VHT 80 MHz</td> <td>5775</td> <td>1 Channels</td> </tr> </tbody> </table>		Mode	Frequency Range (MHz)	Number of Channels	U-NII-1	IEEE 802.11a	5180 ~ 5240	4 Channels	IEEE 802.11n HT 20 MHz	5180 ~ 5240	4 Channels	IEEE 802.11n HT 40 MHz	5190 ~ 5230	2 Channels	IEEE 802.11ac VHT 80 MHz	5210	1 Channels	U-NII-3	IEEE 802.11a	5745 ~ 5825	5 Channels	IEEE 802.11n HT 20 MHz	5745 ~ 5825	5 Channels	IEEE 802.11n HT 40 MHz	5755 ~ 5795	2 Channels	IEEE 802.11ac VHT 80 MHz	5775	1 Channels
	Mode	Frequency Range (MHz)	Number of Channels																												
U-NII-1	IEEE 802.11a	5180 ~ 5240	4 Channels																												
	IEEE 802.11n HT 20 MHz	5180 ~ 5240	4 Channels																												
	IEEE 802.11n HT 40 MHz	5190 ~ 5230	2 Channels																												
	IEEE 802.11ac VHT 80 MHz	5210	1 Channels																												
U-NII-3	IEEE 802.11a	5745 ~ 5825	5 Channels																												
	IEEE 802.11n HT 20 MHz	5745 ~ 5825	5 Channels																												
	IEEE 802.11n HT 40 MHz	5755 ~ 5795	2 Channels																												
	IEEE 802.11ac VHT 80 MHz	5775	1 Channels																												

Remark:

1. EUT pre-scanned data rate of output power for each mode, the worst data rate were recorded in this report.
2. Covered modes are test reduction modes. The output powers on the covered modes are equal to or less than the mode referenced and use the same module

3.2 THE WORST MODE OF MEASUREMENT

For PIFA Antenna

Radiated Emission Measurement Above 1G	
Test Condition	Band edge, Emission for Unwanted and Fundamental
Power supply Mode	Mode 1: EUT power by host system
Worst Mode	<input checked="" type="checkbox"/> Mode 1 <input type="checkbox"/> Mode 2 <input type="checkbox"/> Mode 3 <input type="checkbox"/> Mode 4
Worst Position	<input type="checkbox"/> Placed in fixed position. <input checked="" type="checkbox"/> Placed in fixed position at X-Plane (E2-Plane) <input type="checkbox"/> Placed in fixed position at Y-Plane (E1-Plane) <input type="checkbox"/> Placed in fixed position at Z-Plane (H-Plane)
Worst Polarity	<input checked="" type="checkbox"/> Horizontal <input type="checkbox"/> Vertical

Radiated Emission Measurement Below 1G	
Test Condition	Radiated Emission Below 1G
Power supply Mode	Mode 1: EUT power by host system
Worst Mode	<input checked="" type="checkbox"/> Mode 1 <input type="checkbox"/> Mode 2 <input type="checkbox"/> Mode 3 <input type="checkbox"/> Mode 4

Remark:

1. The worst mode was record in this test report.
2. EUT pre-scanned in three axis, X, Y, Z and two polarity, Horizontal and Vertical for radiated measurement. The worst case (X-Plane and Horizontal) were recorded in this report
3. AC power line conducted emission and for below 1G radiation emission were performed the EUT transmit at the highest output power channel as worse case.

For Dipole Antenna

AC Power Line Conducted Emission	
Test Condition	AC Power line conducted emission for line and neutral
Power supply Mode	Mode 1: EUT power by host system
Worst Mode	<input checked="" type="checkbox"/> Mode 1 <input type="checkbox"/> Mode 2 <input type="checkbox"/> Mode 3 <input type="checkbox"/> Mode 4

Radiated Emission Measurement Above 1G	
Test Condition	Band edge, Emission for Unwanted and Fundamental
Power supply Mode	Mode 1: EUT power by host system
Worst Mode	<input checked="" type="checkbox"/> Mode 1 <input type="checkbox"/> Mode 2 <input type="checkbox"/> Mode 3 <input type="checkbox"/> Mode 4
Worst Position	<input type="checkbox"/> Placed in fixed position. <input type="checkbox"/> Placed in fixed position at X-Plane (E2-Plane) <input type="checkbox"/> Placed in fixed position at Y-Plane (E1-Plane) <input checked="" type="checkbox"/> Placed in fixed position at Z-Plane (H-Plane)
Worst Polarity	<input type="checkbox"/> Horizontal <input checked="" type="checkbox"/> Vertical

Radiated Emission Measurement Below 1G	
Test Condition	Radiated Emission Below 1G
Power supply Mode	Mode 1: EUT power by host system
Worst Mode	<input checked="" type="checkbox"/> Mode 1 <input type="checkbox"/> Mode 2 <input type="checkbox"/> Mode 3 <input type="checkbox"/> Mode 4

Remark:

1. The worst mode was record in this test report.
2. EUT pre-scanned in three axis, X, Y, Z and two polarity, Horizontal and Vertical for radiated measurement. The worst case (Z-Plane and Vertical) were recorded in this report
3. AC power line conducted emission and for below 1G radiation emission were performed the EUT transmit at the highest output power channel as worse case.

Report No.: T180627D11-RP4

3.3 EUT DUTY CYCLE

Duty Cycle				
Configuration	TX ON (ms)	TX ALL (ms)	Duty Cycle (%)	Duty Factor(dB)
802.11a	1.4600	1.5200	96.05%	-0.17
802.11n HT20	1.3600	1.4100	96.45%	-0.16
802.11n HT40	0.7000	0.7400	94.59%	-0.24
802.11ac VHT80	0.3600	0.4000	90.00%	-0.46

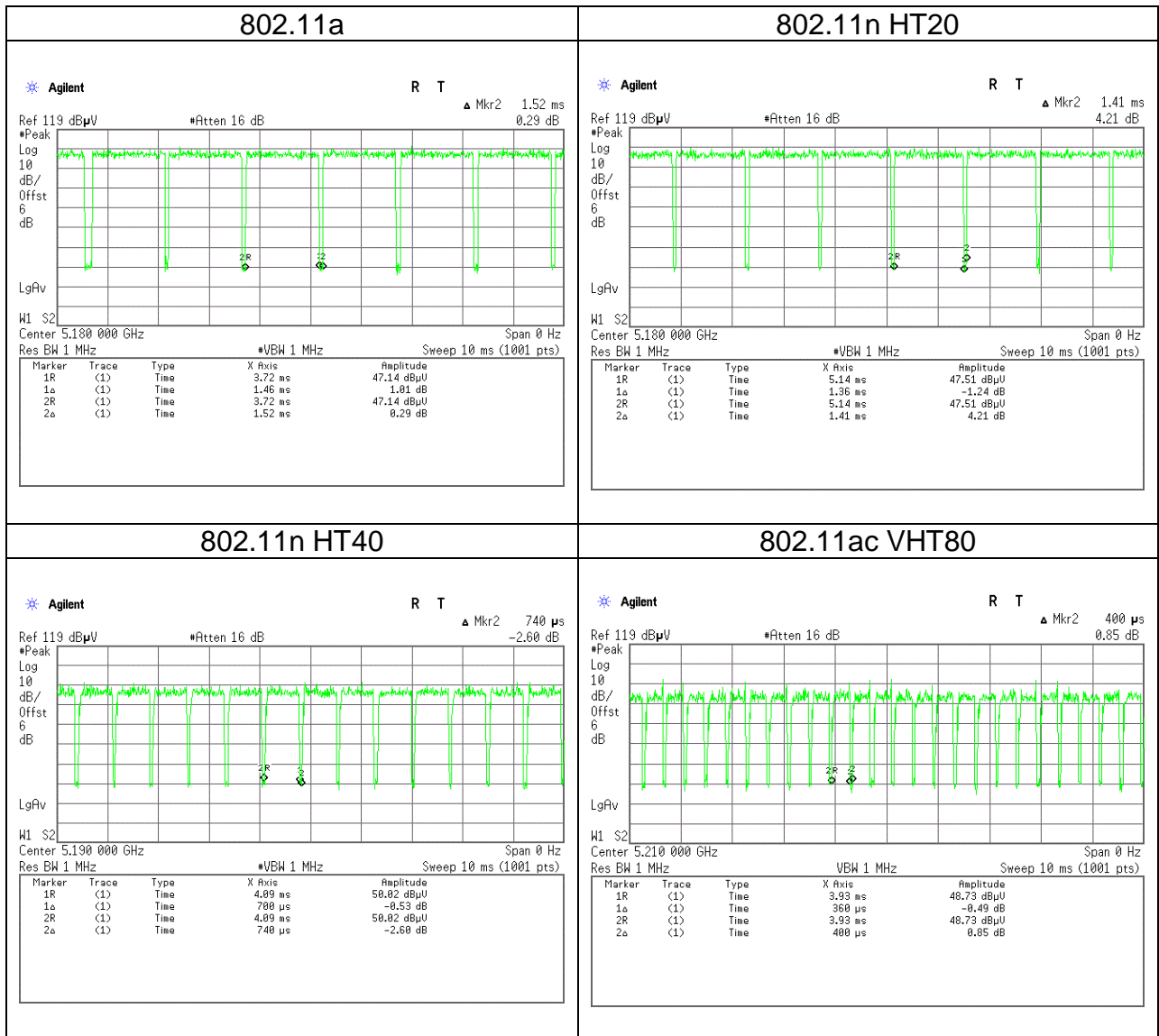

Report No.: T180627D11-RP4

4. TEST RESULT

4.1 AC POWER LINE CONDUCTED EMISSION

4.1.1 Test Limit

According to §15.207(a)

Frequency Range (MHz)	Limits(dBµV)	
	Quasi-peak	Average
0.15 to 0.50	66 to 56*	56 to 46*
0.50 to 5	56	46
5 to 30	60	50

* Decreases with the logarithm of the frequency.

4.1.2 Test Procedure

Test method Refer as ANSI 63.10:2013 clause 6.2,

1. The EUT was placed on a non-conducted table, which is 0.8m above horizontal ground plane and 0.4m above vertical ground plane.
2. EUT connected to the line impedance stabilization network (LISN)
3. Receiver set RBW of 9kHz and Detector Peak, and note as quasi-peak and average.
4. Maximum procedure was performed on the six highest emissions to ensure EUT compliance.
5. Recorded Line for Neutral and Line.

4.1.3 Test Setup

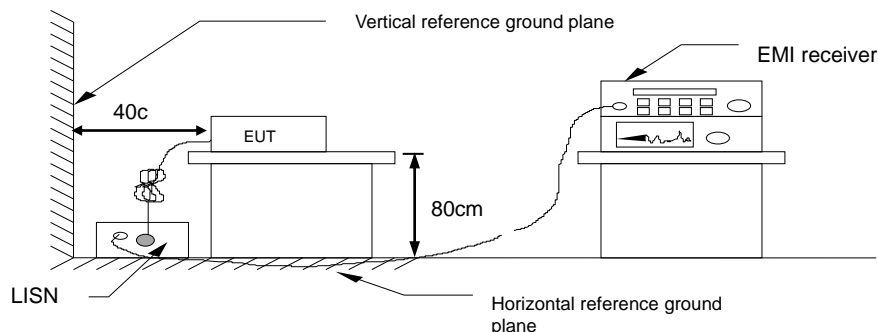

4.1.4 Test Result

Pass.

Test Data

Test Mode:	Mode 1	Temp/Hum	24(°C)/ 50%RH
Phase:	Line	Test Date	July 19, 2018
Test Voltage:	120Vac	Test Engineer	Dally Hong

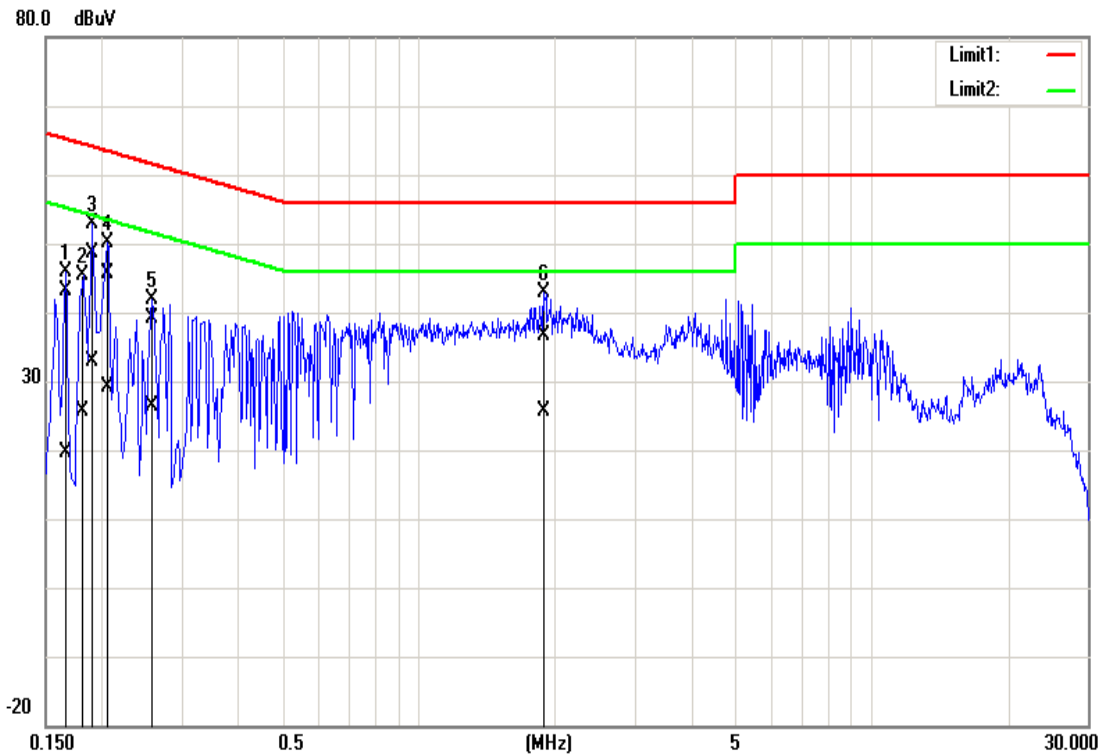

Frequency (MHz)	Quasi Peak reading (dBuV)	Average reading (dBuV)	Correction factor (dB)	Quasi Peak result (dBuV)	Average result (dBuV)	Quasi Peak limit (dBuV)	Average limit (dBuV)	Quasi Peak margin (dB)	Average margin (dB)	Remark
0.1660	43.06	19.41	0.11	43.17	19.52	65.16	55.16	-21.99	-35.64	Pass
0.1820	45.33	25.48	0.11	45.44	25.59	64.39	54.39	-18.95	-28.80	Pass
0.1900	48.46	32.72	0.11	48.57	32.83	64.04	54.04	-15.47	-21.21	Pass
0.2060	45.57	28.98	0.11	45.68	29.09	63.37	53.37	-17.69	-24.28	Pass
0.2580	39.04	26.23	0.11	39.15	26.34	61.50	51.50	-22.35	-25.16	Pass
1.8940	36.51	25.54	0.15	36.66	25.69	56.00	46.00	-19.34	-20.31	Pass

Test Mode:	Mode 1	Temp/Hum	24(°C)/ 50%RH
Phase:	Neutral	Test Date	July 19, 2018
Test Voltage:	120Vac	Test Engineer	Dally Hong

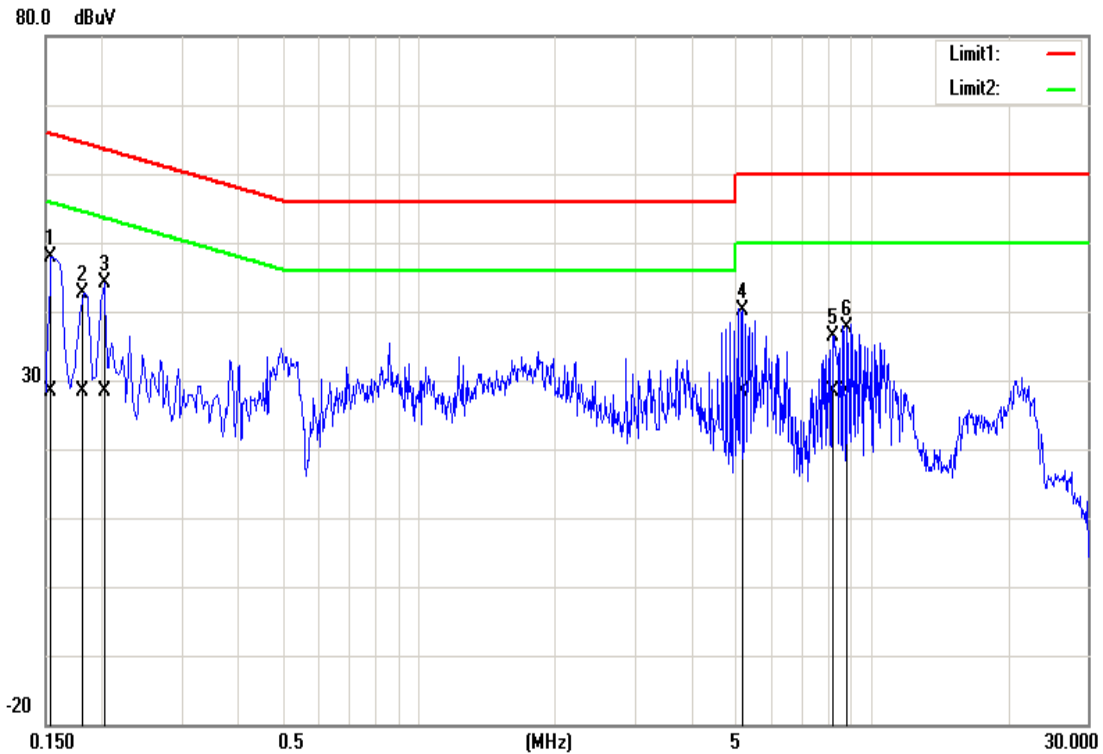

Frequency (MHz)	Quasi Peak reading (dBuV)	Average reading (dBu)	Correction factor (dB)	Quasi Peak result (dBuV)	Average result (dBuV)	Quasi Peak limit (dBuV)	Average limit (dBuV)	Quasi Peak margin (dB)	Average margin (dB)	Remark
1.8940	31.03	22.97	0.16	31.19	23.13	56.00	46.00	-24.81	-22.87	Pass
0.1825	40.91	28.44	0.13	41.04	28.57	64.37	54.37	-23.33	-25.80	Pass
0.2007	40.02	26.02	0.13	40.15	26.15	63.58	53.58	-23.43	-27.43	Pass
5.1660	39.14	35.87	0.22	39.36	36.09	60.00	50.00	-20.64	-13.91	Pass
8.2300	34.97	30.49	0.27	35.24	30.76	60.00	50.00	-24.76	-19.24	Pass
8.7020	35.42	26.13	0.28	35.70	26.41	60.00	50.00	-24.30	-23.59	Pass

4.2 26dB BANDWIDTH, 6dB BANDWIDTH AND OCCUPIED BANDWIDTH (99%)

4.2.1 Test Limit

26 dB Bandwidth : For reporting purposes only.

6 dB Bandwidth : Least 500kHz.

Occupied Bandwidth(99%) : For reporting purposes only.

4.2.2 Test Procedure

Test method Refer as KDB 789033 D02 Section C, D, and ANSI 63.10:2013 clause 6.9.2,

1. The EUT RF output connected to the spectrum analyzer by RF cable.
2. Setting maximum power transmit of EUT
3. UNII-1
 - (1) BW=20MHz : SA set RBW = 300kHz, VBW = 1MHz and Detector = Peak, to measurement 26 dB Bandwidth and 99% Bandwidth
 - (2) BW=40MHz : SA set RBW = 1MHz, VBW = 3MHz and Detector = Peak, to measurement 26 dB Bandwidth and 99% Bandwidth
 - (3) BW=80MHz : SA set RBW = 1MHz, VBW = 3MHz and Detector = Peak, to measurement 26 dB Bandwidth and 99% Bandwidth
4. UNII-3, SA set RBW = 100kHz, VBW = 300kHz and Detector = Peak, to measurement 6 dB Bandwidth and 99% Bandwidth
5. SA set RBW = 1% ~ 5% OBW, VBW = three times the RBW and Detector = Peak, to measurement 99% Bandwidth
6. Measure and record the result of 6 dB Bandwidth and 99% Bandwidth. in the test report.

4.2.3 Test Setup



Report No.: T180627D11-RP4

4.2.4 Test Result

UNII-1 5150-5250 MHz			
Test mode: IEEE 802.11a mode			
Channel	Frequency (MHz)	OBW (99%) (MHz)	26dB BW (MHz)
Low	5180	16.2807	19.8551
Mid	5220	16.2807	19.8551
High	5240	16.3531	19.9275
Test mode: IEEE 802.11n HT20 mode			
Channel	Frequency (MHz)	OBW (99%) (MHz)	26dB BW (MHz)
Low	5180	17.3661	19.682
Mid	5220	17.3661	19.247
High	5240	17.3661	19.247
Test mode: IEEE 802.11n HT40 mode			
Channel	Frequency (MHz)	OBW (99%) (MHz)	26dB BW (MHz)
Low	5190	36.0057	39.02
High	5230	35.8900	39.13
Test mode: IEEE 802.11ac VHT80 mode			
Channel	Frequency (MHz)	OBW (99%) (MHz)	26dB BW (MHz)
Mid	5210	75.0217	79.88

UNII-3 5725-5825MHz			
Test mode: IEEE 802.11a mode			
Channel	Frequency (MHz)	OBW(99%) (MHz)	6dB BW (MHz)
Low	5745	16.2807	15.1739
Mid	5785	16.2807	15.1739
High	5825	16.2807	15.1739
Test mode: IEEE 802.11n HT20 mode			
Channel	Frequency (MHz)	OBW(99%) (MHz)	6dB BW (MHz)
Low	5745	17.4384	15.1739
Mid	5785	17.3661	15.087
High	5825	17.4384	15.1304
Test mode: IEEE 802.11n HT40 mode			
Channel	Frequency (MHz)	OBW(99%) (MHz)	6dB BW (MHz)
Low	5755	36.0057	35.13
High	5795	37.6266	35.13
Test mode: IEEE 802.11ac VHT80 mode			
Channel	Frequency (MHz)	OBW(99%) (MHz)	6dB BW (MHz)
Mid	5775	75.4848	75.13

Report No.: T180627D11-RP4

Test Data (26dB BANDWIDTH)

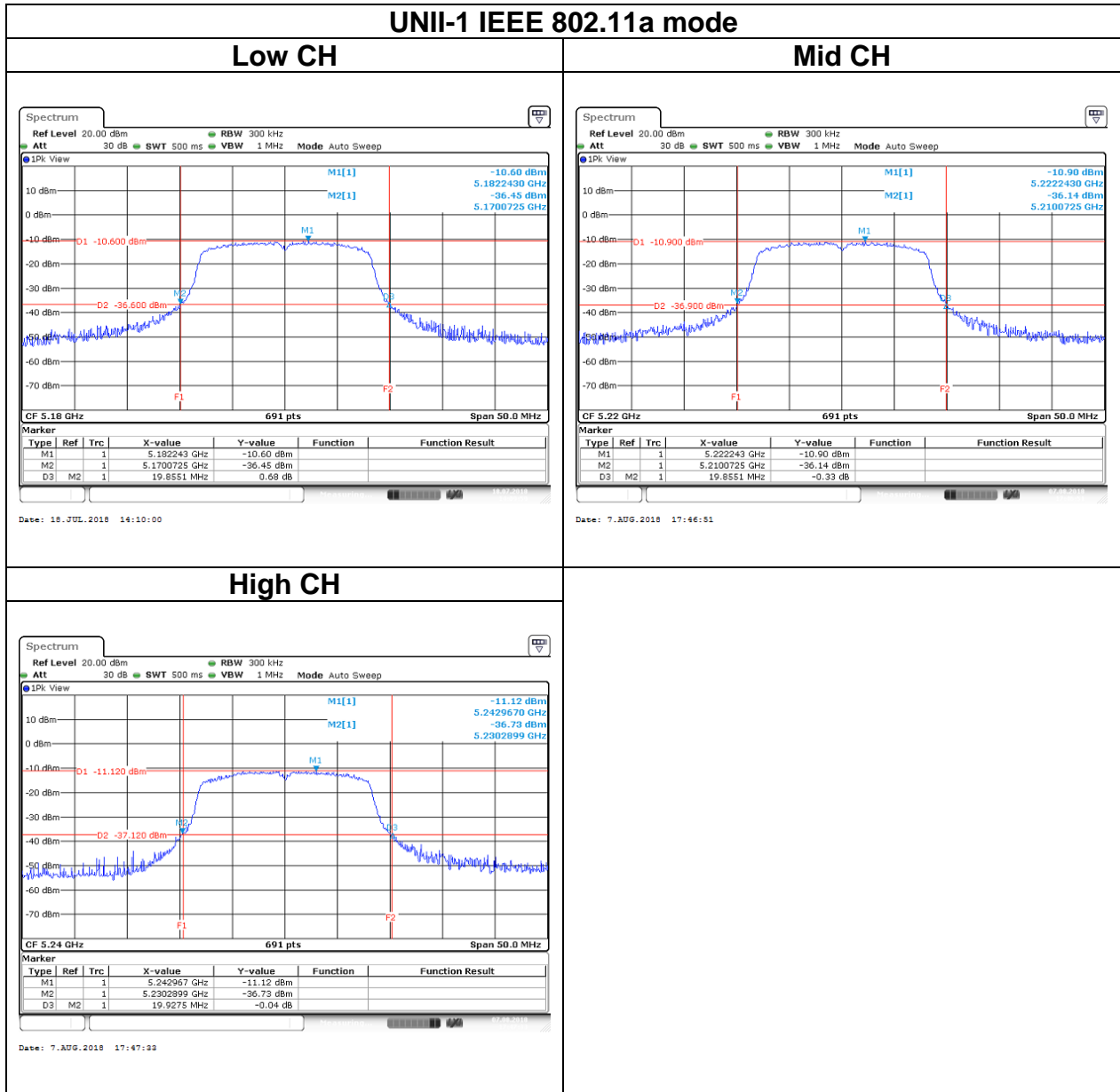

Report No.: T180627D11-RP4

UNII-1 IEEE 802.11n HT20 mode

Low CH

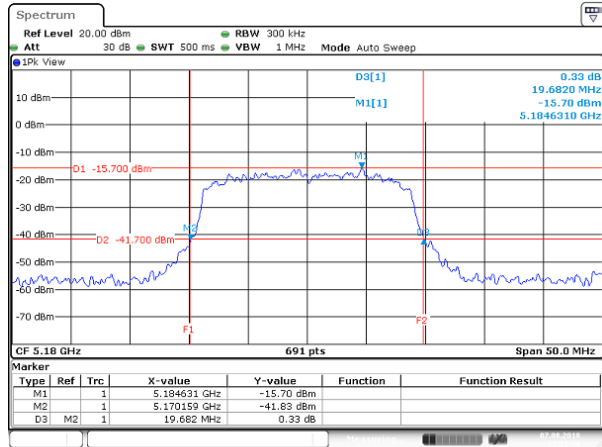

Mid CH

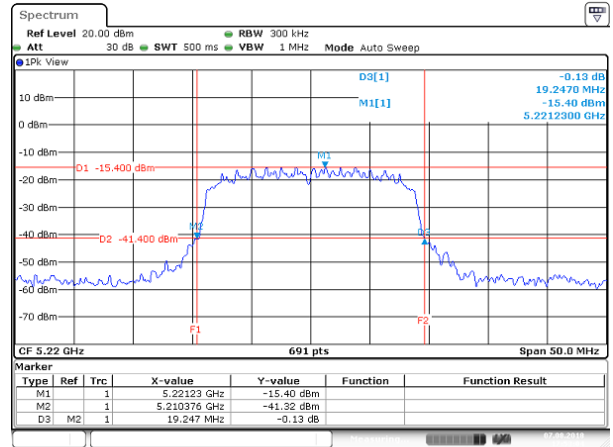

High CH

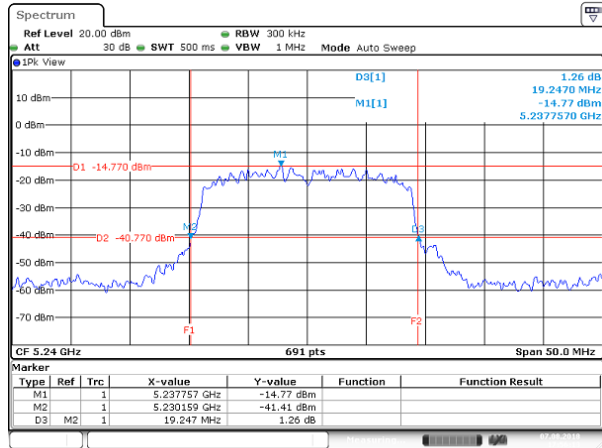

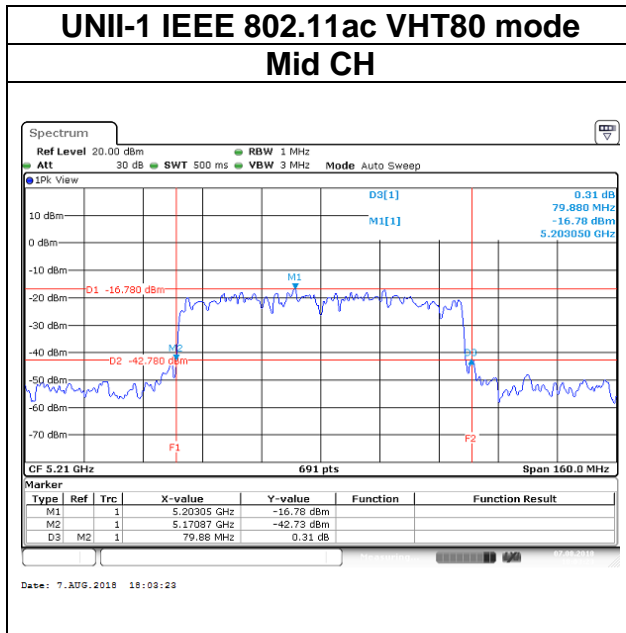
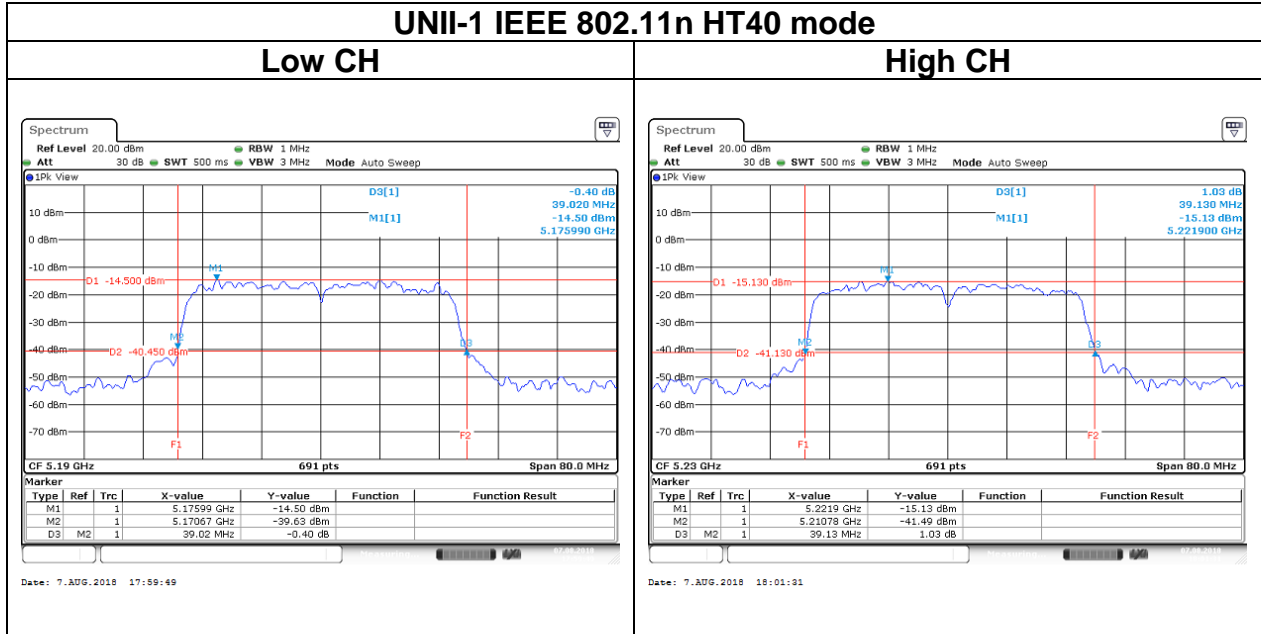

Report No.: T180627D11-RP4

Test Data (6dB BANDWIDTH)

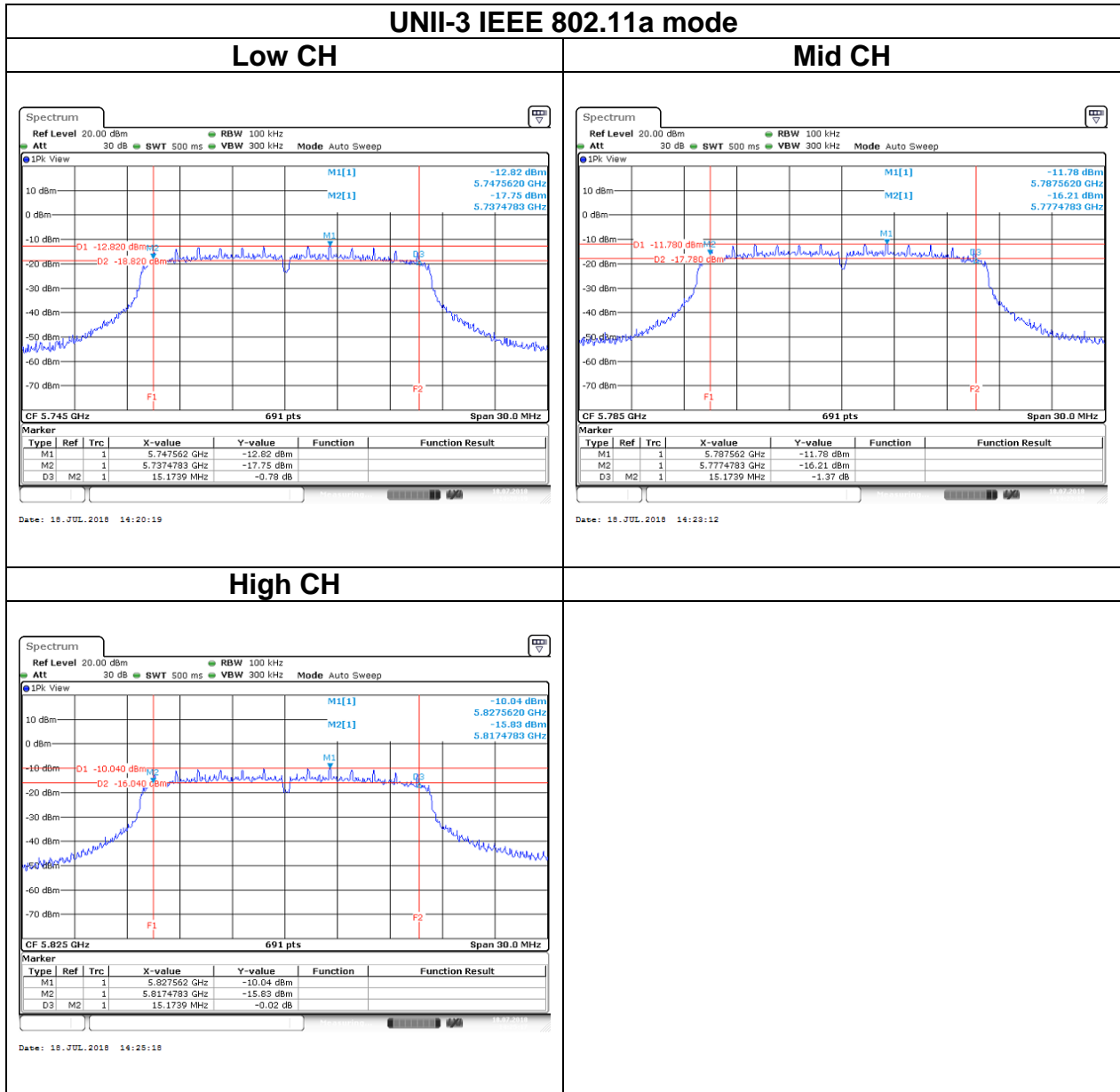

Report No.: T180627D11-RP4

UNII-3 IEEE 802.11n HT20 mode

Low CH

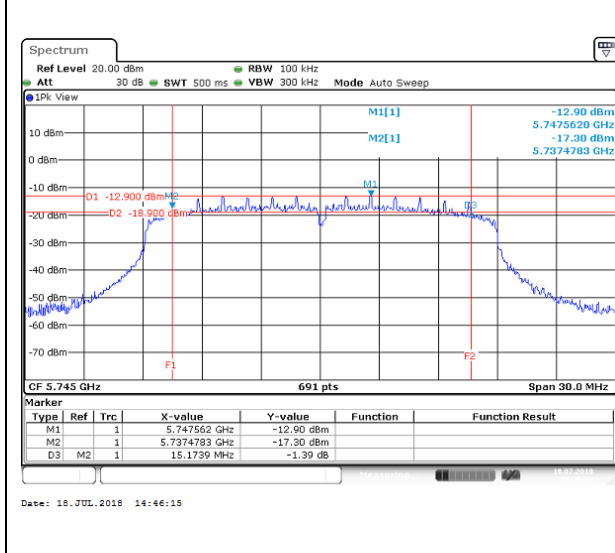

Mid CH

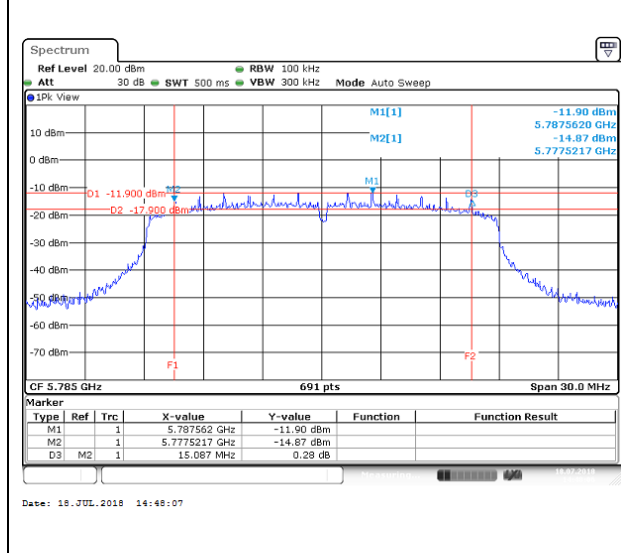

High CH

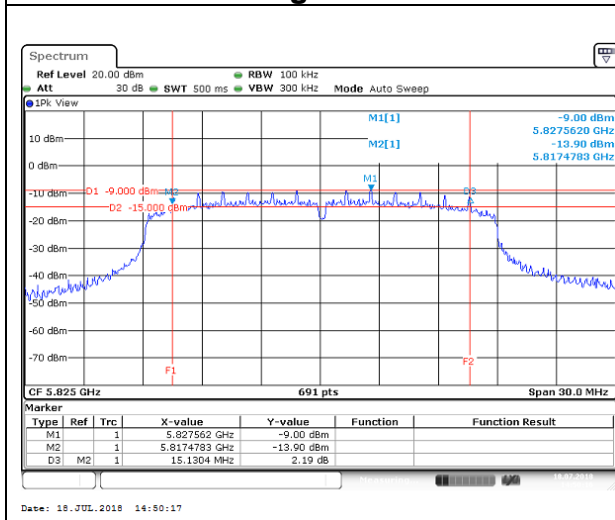

Report No.: T180627D11-RP4

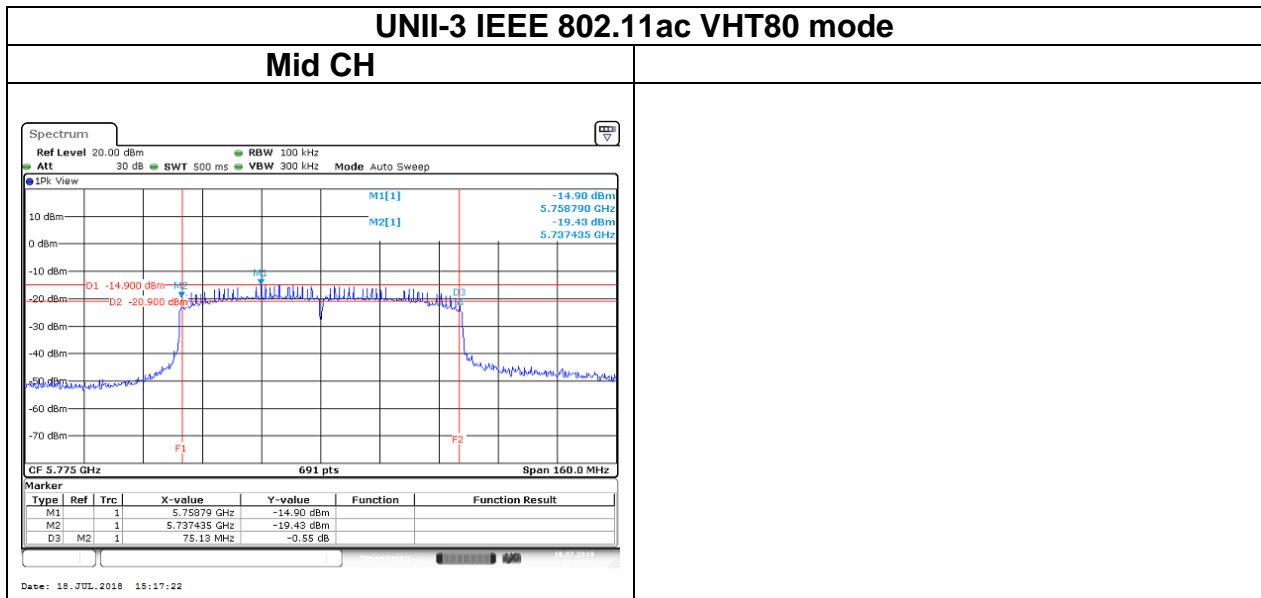
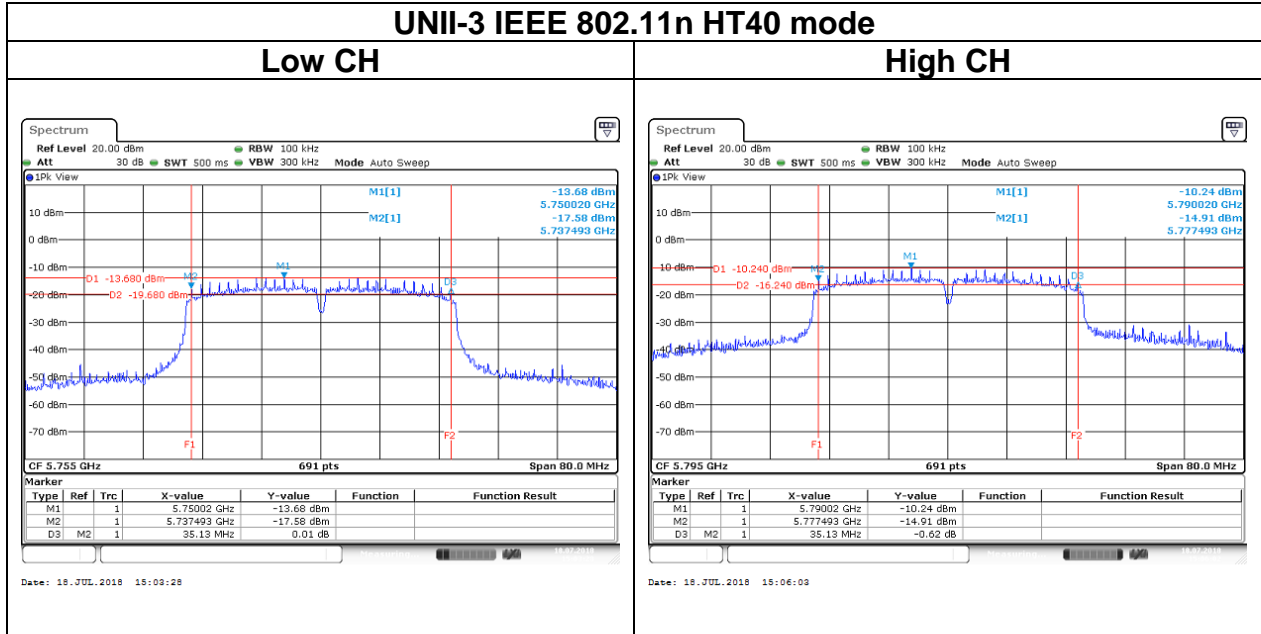

Test Data (BANDWIDTH 99%)

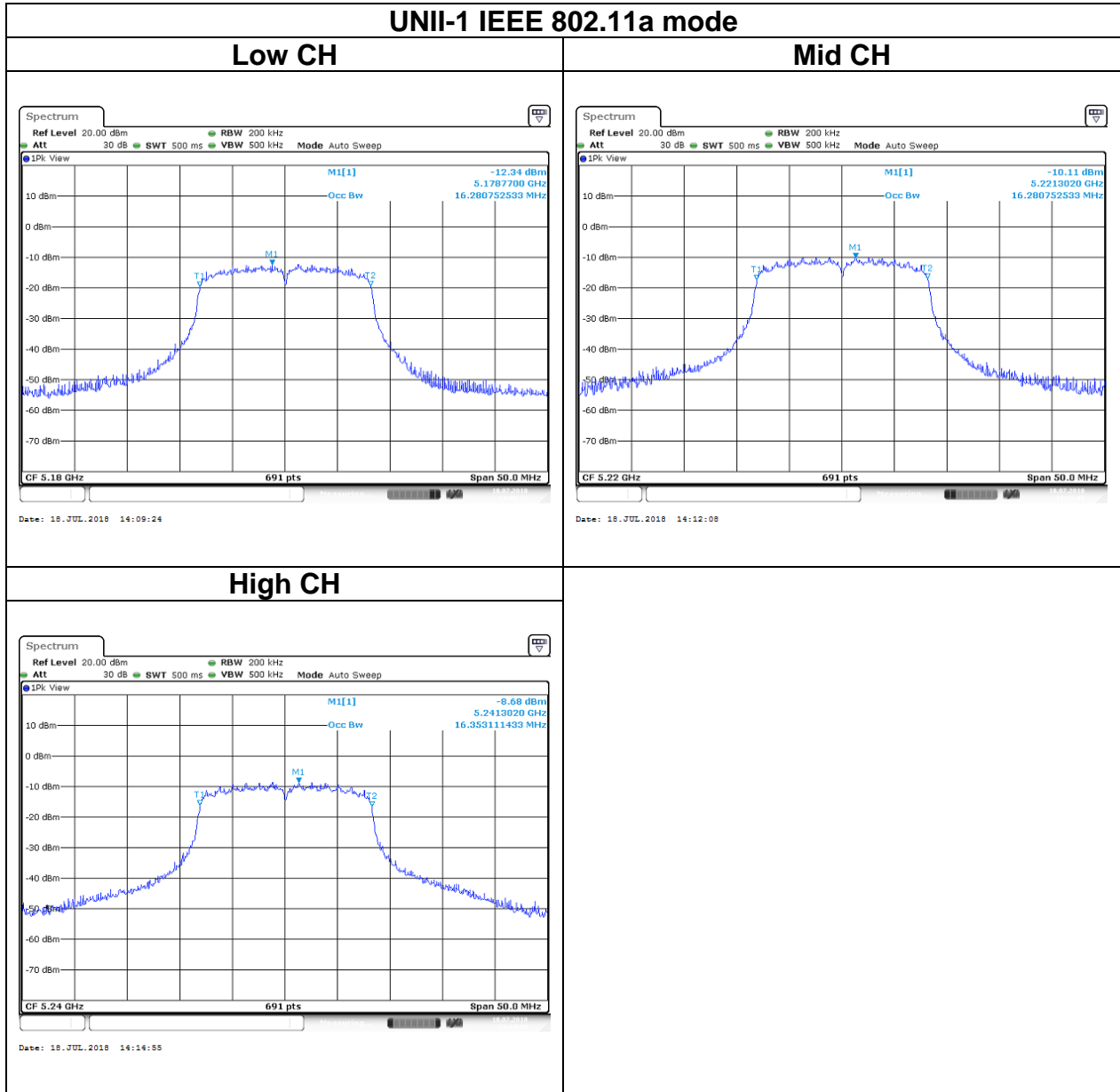

Report No.: T180627D11-RP4

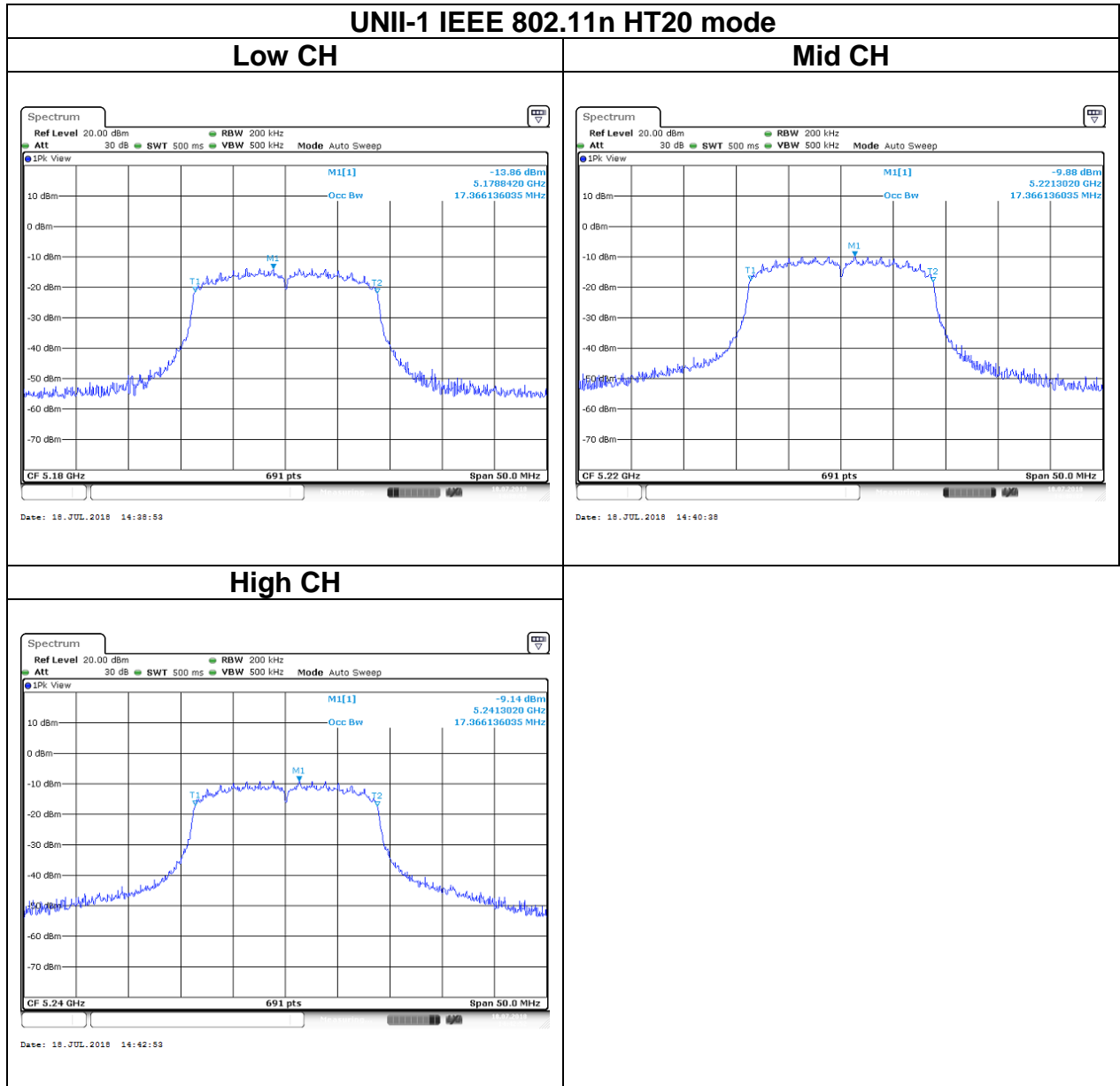

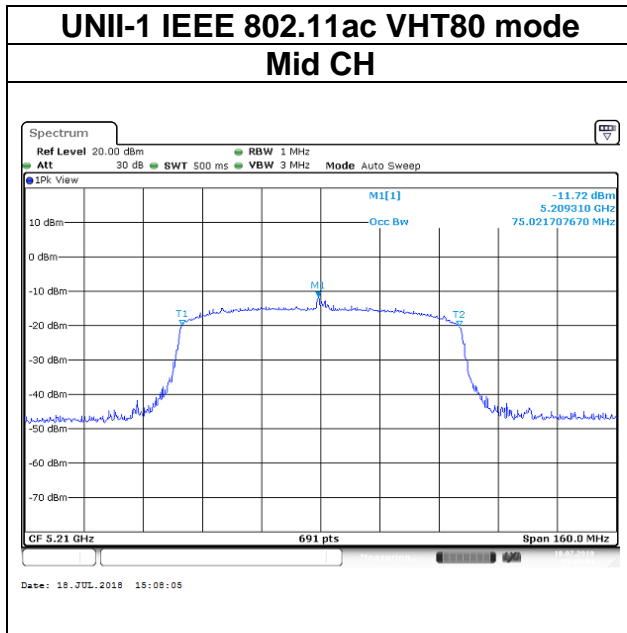
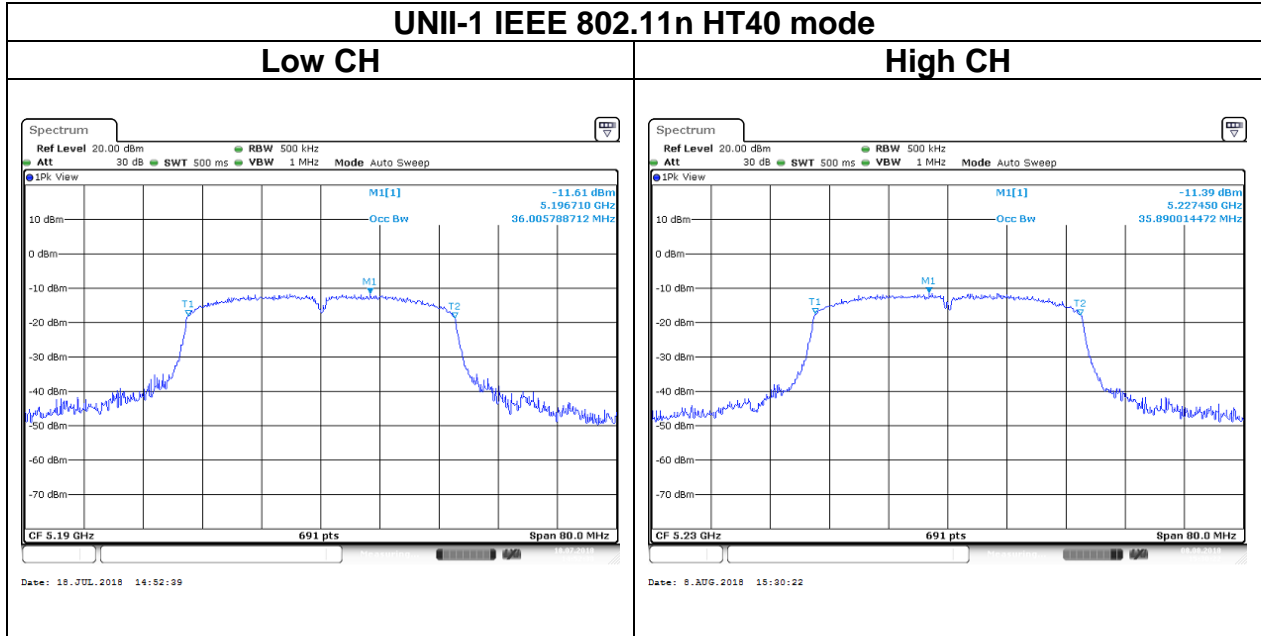

Report No.: T180627D11-RP4

UNII-3 IEEE 802.11a mode

Low CH

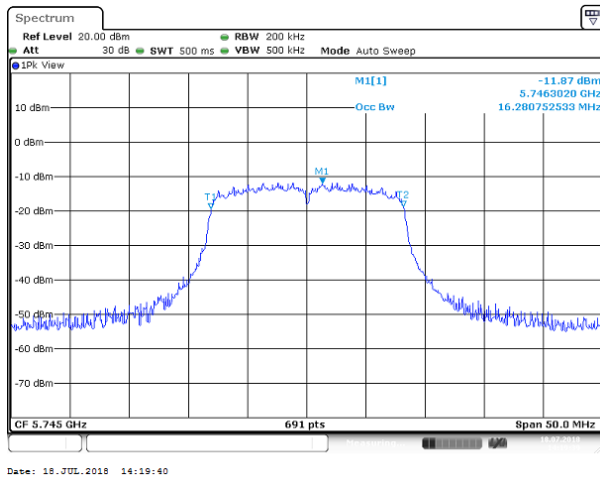

Date: 18 JUL 2018 14:19:40

Mid CH

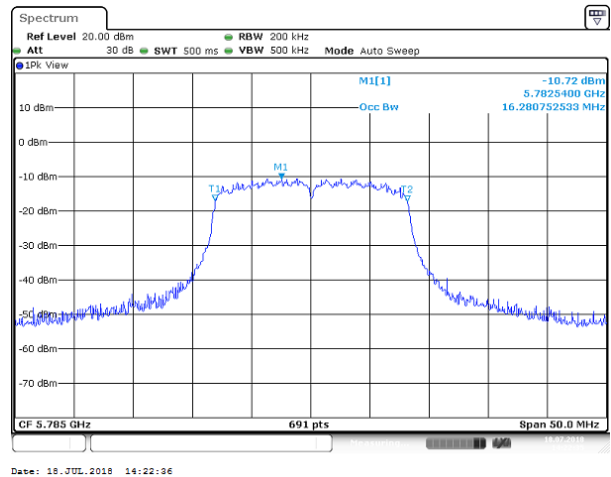

Date: 18 JUL 2018 14:22:36

High CH

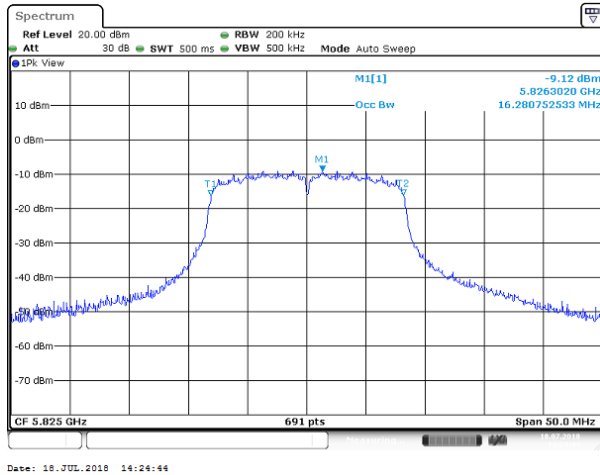

Date: 18 JUL 2018 14:24:44

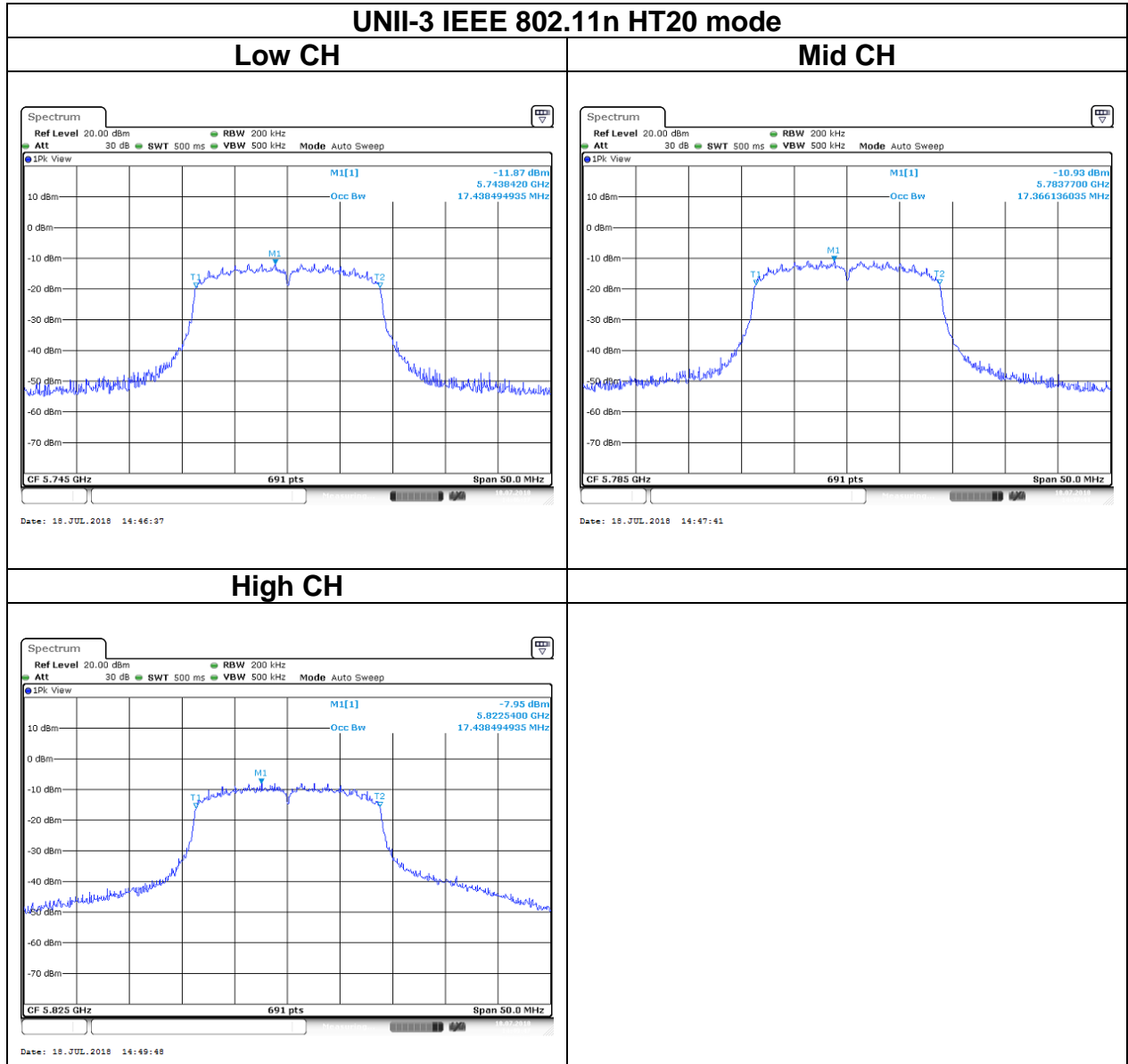

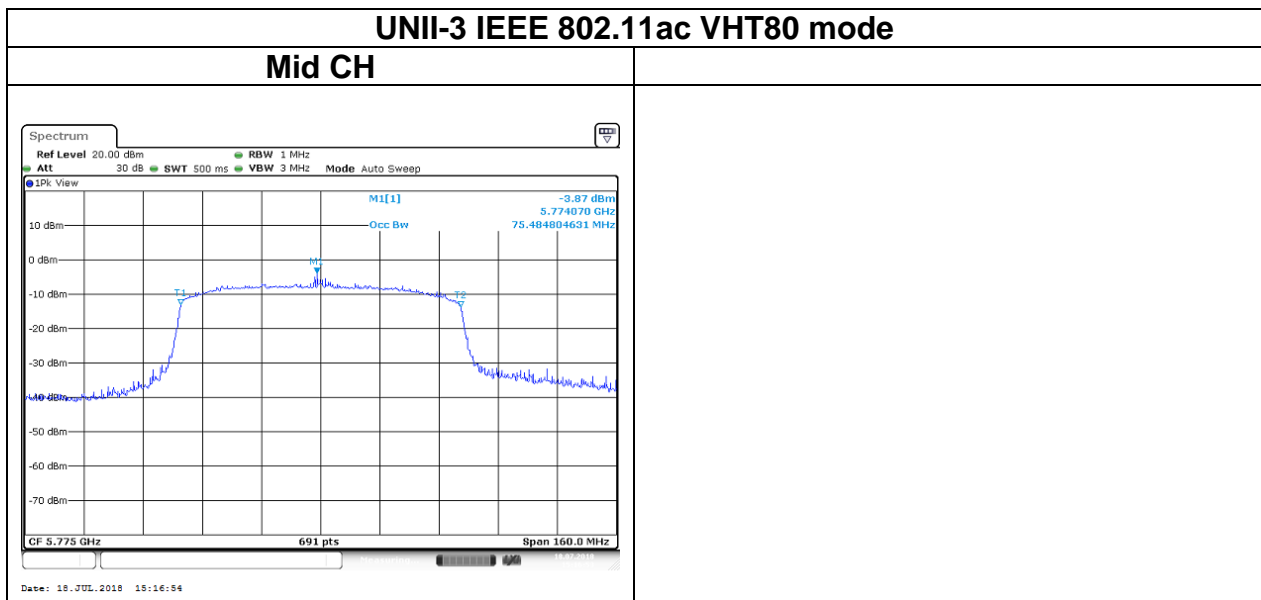
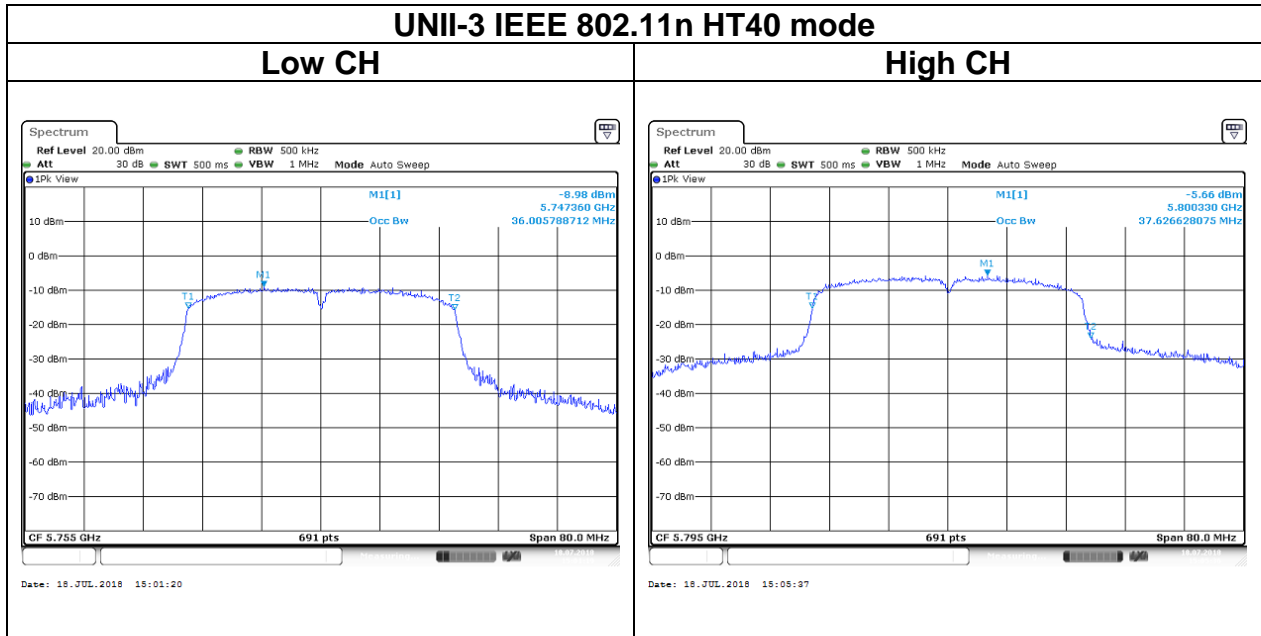

4.3 OUTPUT POWER MEASUREMENT

4.3.1 Test Limit

According to §15.407 (a)(1), 15.407(a)(3)

UNII-1 :

For client devices in the 5.15-5.25 GHz band, the maximum conducted output power over the frequency band of operation shall not exceed 250 mW provided the maximum antenna gain does not exceed 6 dBi. In addition, the maximum power spectral density shall not exceed 11 dBm in any 1 megahertz band. If transmitting antennas of directional gain greater than 6 dBi are used, both the maximum conducted output power and the maximum power spectral density shall be reduced by the amount in dB that the directional gain of the antenna exceeds 6 dBi.

UNII-3:

For the band 5.725-5.85 GHz, the maximum conducted output power over the frequency band of operation shall not exceed 1 W. In addition, the maximum power spectral density shall not exceed 30 dBm in any 500-kHz band. If transmitting antennas of directional gain greater than 6 dBi are used, both the maximum conducted output power and the maximum power spectral density shall be reduced by the amount in dB that the directional gain of the antenna exceeds 6 dBi.

UNII-1 Limit	<input checked="" type="checkbox"/> Antenna not exceed 6 dBi : 24dBm <input type="checkbox"/> Antenna with DG greater than 6 dBi : [Limit = 24 – (DG – 6)]
UNII-3 Limit	<input checked="" type="checkbox"/> Antenna not exceed 6 dBi : 30dBm <input type="checkbox"/> Antenna with DG greater than 6 dBi : [Limit = 30 – (DG – 6)]

4.3.2 Test Procedure

Test method Refer as KDB 789033 D02, Section E.3.b.

1. The EUT RF output connected to the power meter by RF cable.
2. Setting maximum power transmit of EUT.
3. The path loss was compensated to the results for each measurement.
4. Measure and record the result of Average output power. in the test report.

4.3.3 Test Setup

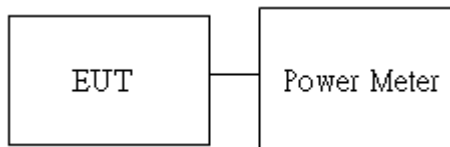

Report No.: T180627D11-RP4

4.3.4 Test Result

Conducted output power :

UNII-1							
Config	CH	Freq. (MHz)	Power Set	AV Power (dBm)	AV Total Power (dBm)	AV Total Power (W)	Limit (dBm)
IEEE 802.11a Data rate: 6Mbps	36	5180	11	9.76	9.76	0.0095	24
	44	5220	13	12.90	12.90	0.0195	
	48	5240	14	13.73	13.73	0.0236	
IEEE 802.11n HT20 Data rate: MCS0	36	5180	10	8.61	8.61	0.0073	
	44	5220	13	12.90	12.90	0.0195	
	48	5240	14	13.73	13.73	0.0236	
IEEE 802.11n HT40 Data rate: MCS0	38	5190	11	10.08	10.08	0.0102	
	46	5230	18	16.50	16.50	0.0447	
IEEE 802.11ac VHT80 Data rate: MCS0	42	5210	8	6.82	6.82	0.0048	

UNII-3							
Config	CH	Freq. (MHz)	Power Set	AV Power (dBm)	AV Total Power (dBm)	AV Total Power (W)	Limit (dBm)
IEEE 802.11a Data rate: 6Mbps	149	5745	9	10.12	10.12	0.0103	30
	157	5785	11	11.05	11.05	0.0127	
	165	5825	14	12.73	12.73	0.0187	
IEEE 802.11n HT20 Data rate: MCS0	149	5745	9	9.90	9.90	0.0098	
	157	5785	11	10.87	10.87	0.0122	
	165	5825	15	13.20	13.20	0.0209	
IEEE 802.11n HT40 Data rate: MCS0	151	5755	11	11.64	11.64	0.0146	
	159	5795	16	15.77	15.77	0.0378	
IEEE 802.11ac VHT80 Data rate: MCS0	155	5775	13.00	12.72	12.72	0.0187	

4.4 POWER SPECTRAL DENSITY

4.4.1 Test Limit

According to §15.407 (a)(1), 15.407(a)(3)

UNII-1 :

For client devices in the 5.15-5.25 GHz band, the maximum conducted output power over the frequency band of operation shall not exceed 250 mW provided the maximum antenna gain does not exceed 6 dBi. In addition, the maximum power spectral density shall not exceed 11 dBm in any 1 megahertz band. If transmitting antennas of directional gain greater than 6 dBi are used, both the maximum conducted output power and the maximum power spectral density shall be reduced by the amount in dB that the directional gain of the antenna exceeds 6 dBi.

UNII-3:

For the band 5.725-5.85 GHz, the maximum conducted output power over the frequency band of operation shall not exceed 1 W. In addition, the maximum power spectral density shall not exceed 30 dBm in any 500-kHz band. If transmitting antennas of directional gain greater than 6 dBi are used, both the maximum conducted output power and the maximum power spectral density shall be reduced by the amount in dB that the directional gain of the antenna exceeds 6 dBi.i.

UNII-1 Limit	<input checked="" type="checkbox"/> Antenna not exceed 6 dBi : 11 dBm <input type="checkbox"/> Antenna with DG greater than 6 dBi : [Limit = 11 – (DG – 6)]
UNII-3 Limit	<input checked="" type="checkbox"/> Antenna not exceed 6 dBi : 30 dBm <input type="checkbox"/> Antenna with DG greater than 6 dBi : [Limit = 30 – (DG – 6)]

4.4.2 Test Procedure

Test method Refer as KDB 789033 D02, Section F

1. The EUT RF output connected to the spectrum analyzer by RF cable.
2. Setting maximum power transmit of EUT
3. UNII-1, SA set RBW = 1MHz, VBW = 3MHz and Detector = RMS, to measurement Power Density.
4. UNII-3, SA set RBW = 500kHz, VBW = 2MHz and Detector = RMS, to measurement Power Density
5. The path loss and Duty Factor were compensated to the results for each measurement by SA.
6. Mark the maximum level.
7. Measure and record the result of power spectral density. in the test report.

4.4.3 Test Setup

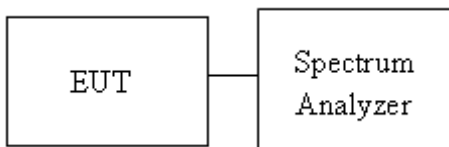

4.4.4 Test Result

UNII-1 5150-5250 MHz			
Test mode: IEEE 802.11a mode			
Channel	Frequency (MHz)	PPSD (dBm)	Limit (dBm)
Low	5180	-13.88	11
Mid	5220	-11.80	
High	5240	-10.37	
Test mode: IEEE 802.11n HT20 mode			
Channel	Frequency (MHz)	PPSD (dBm)	Limit (dBm)
Low	5180	-15.86	11
Mid	5220	-12.01	
High	5240	-11.18	
Test mode: IEEE 802.11n HT40 mode			
Channel	Frequency (MHz)	PPSD (dBm)	Limit (dBm)
Low	5190	-17.56	11
High	5230	-11.80	
Test mode: IEEE 802.11ac VHT80 mode			
Channel	Frequency (MHz)	PPSD (dBm)	Limit (dBm)
Mid	5210	-24.00	11

UNII-3 5725-5825 MHz			
Test mode: IEEE 802.11a mode			
Channel	Frequency (MHz)	PPSD (dBm)	Limit (dBm)
Low	5745	-7.55	30
Mid	5785	-6.38	
High	5825	-4.99	
Test mode: IEEE 802.11n HT20 mode			
Channel	Frequency (MHz)	PPSD (dBm)	Limit (dBm)
Low	5745	-8.16	30
Mid	5785	-6.48	
High	5825	-4.30	
Test mode: IEEE 802.11n HT40 mode			
Channel	Frequency (MHz)	PPSD (dBm)	Limit (dBm)
Low	5755	-0.09	30
High	5795	-0.26	
Test mode: IEEE 802.11ac VHT80 mode			
Channel	Frequency (MHz)	PPSD (dBm)	Limit (dBm)
Mid	5775	-9.75	30

Test Data

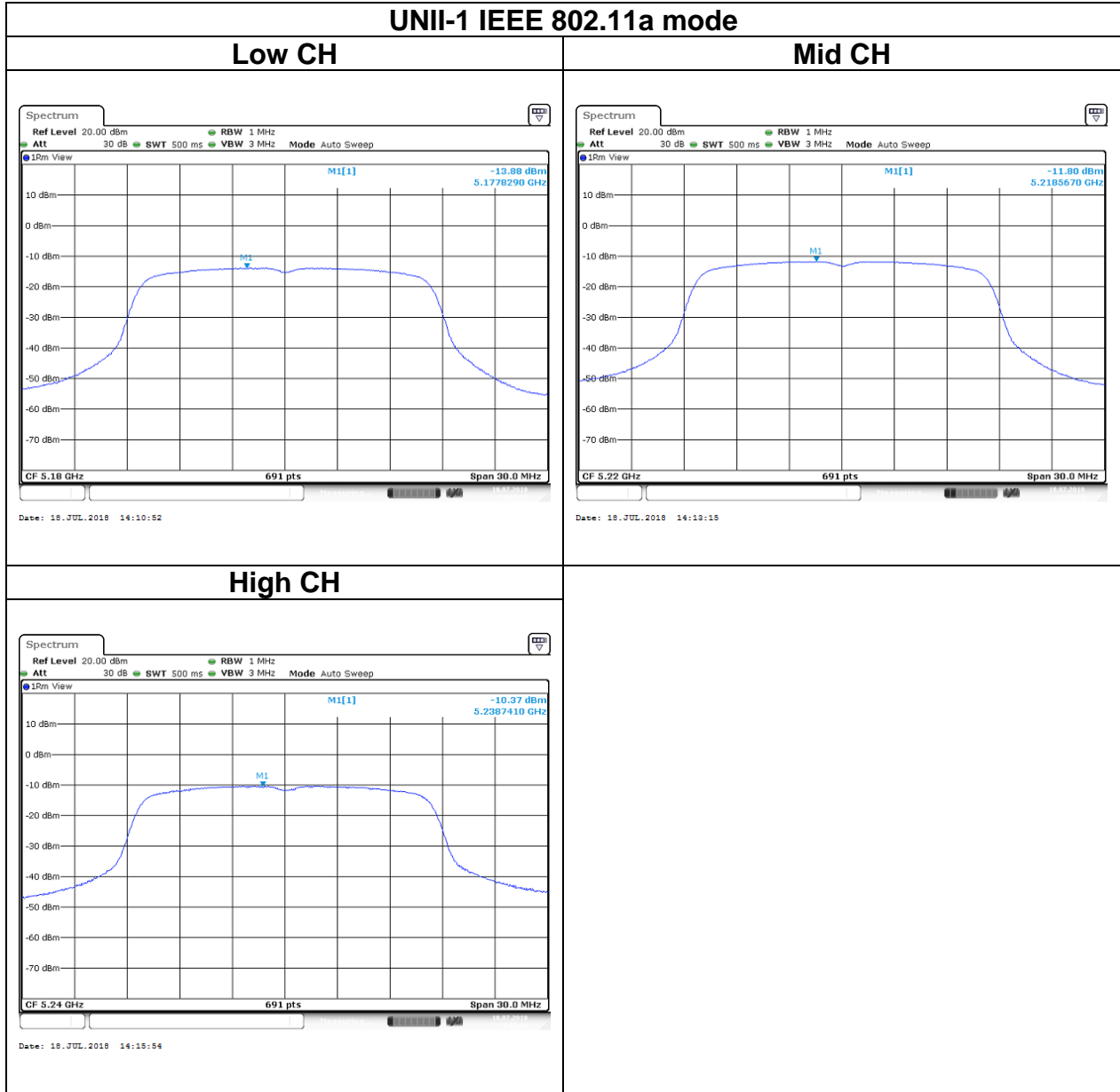

Report No.: T180627D11-RP4

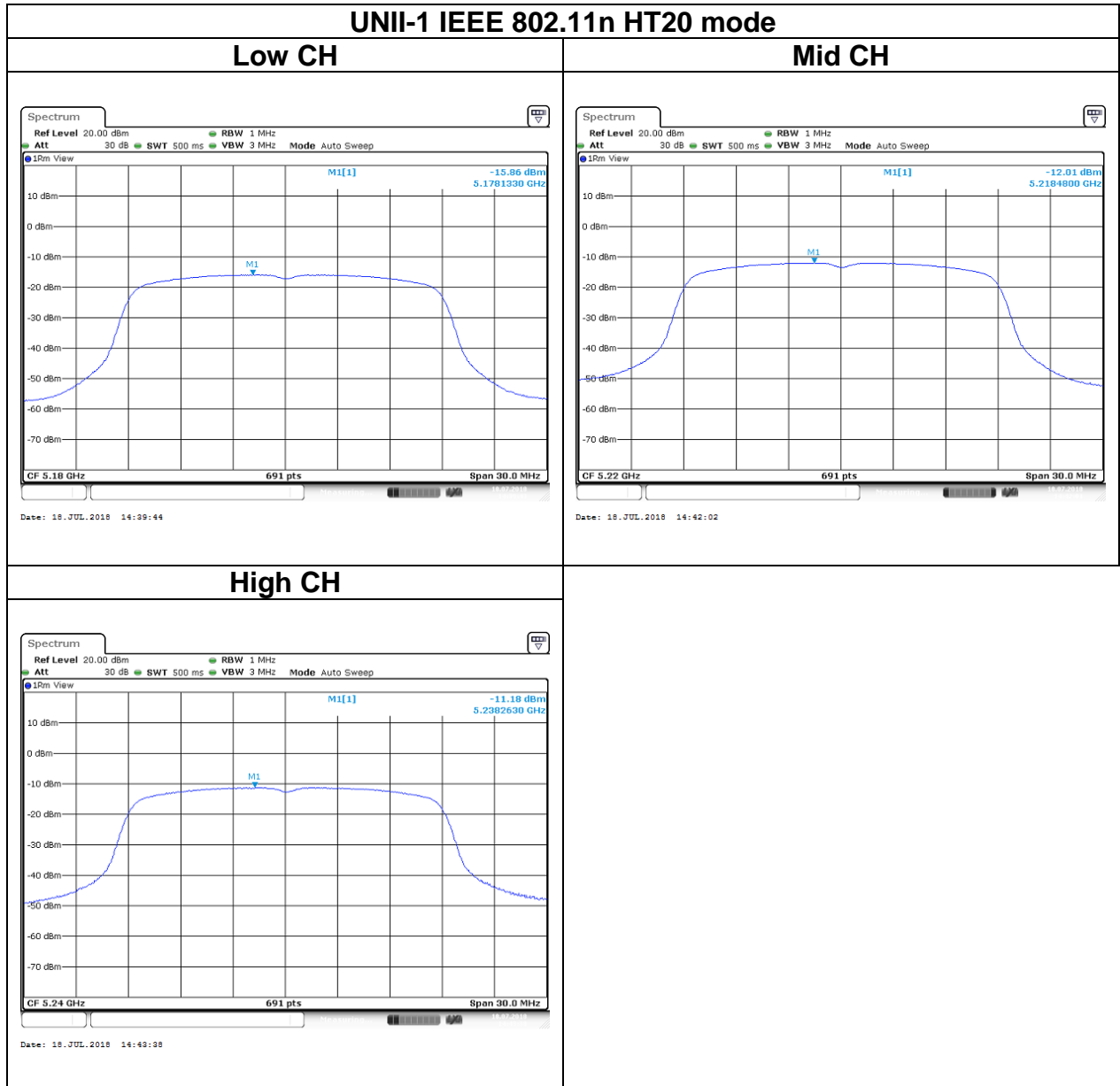

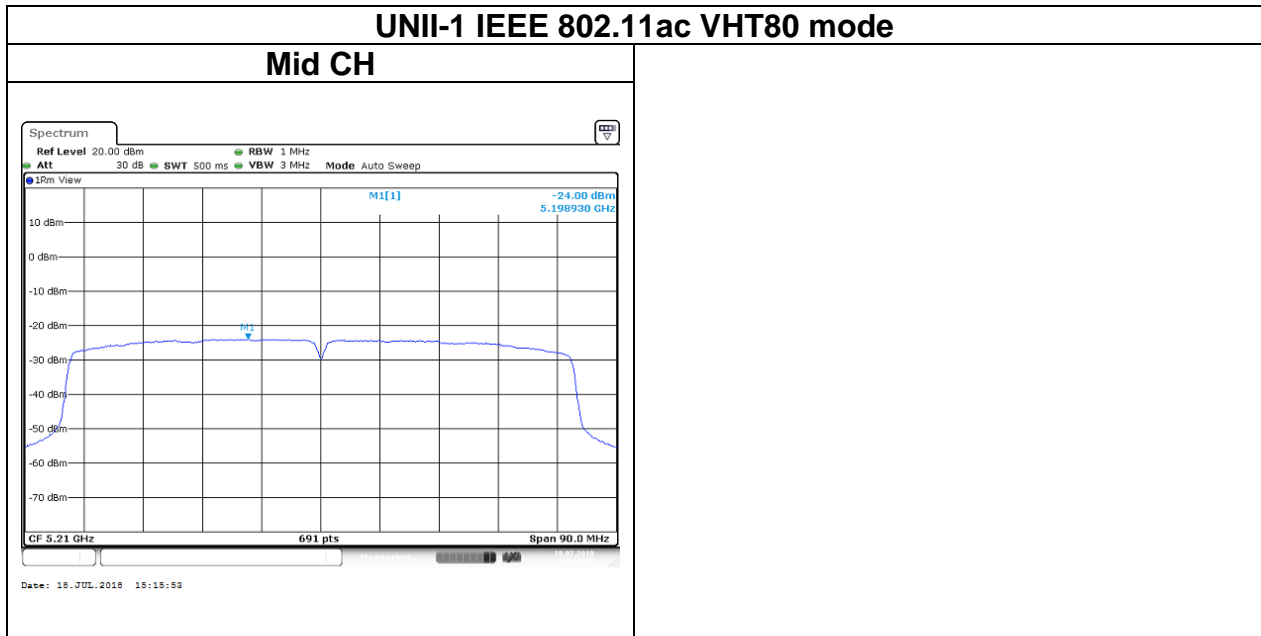
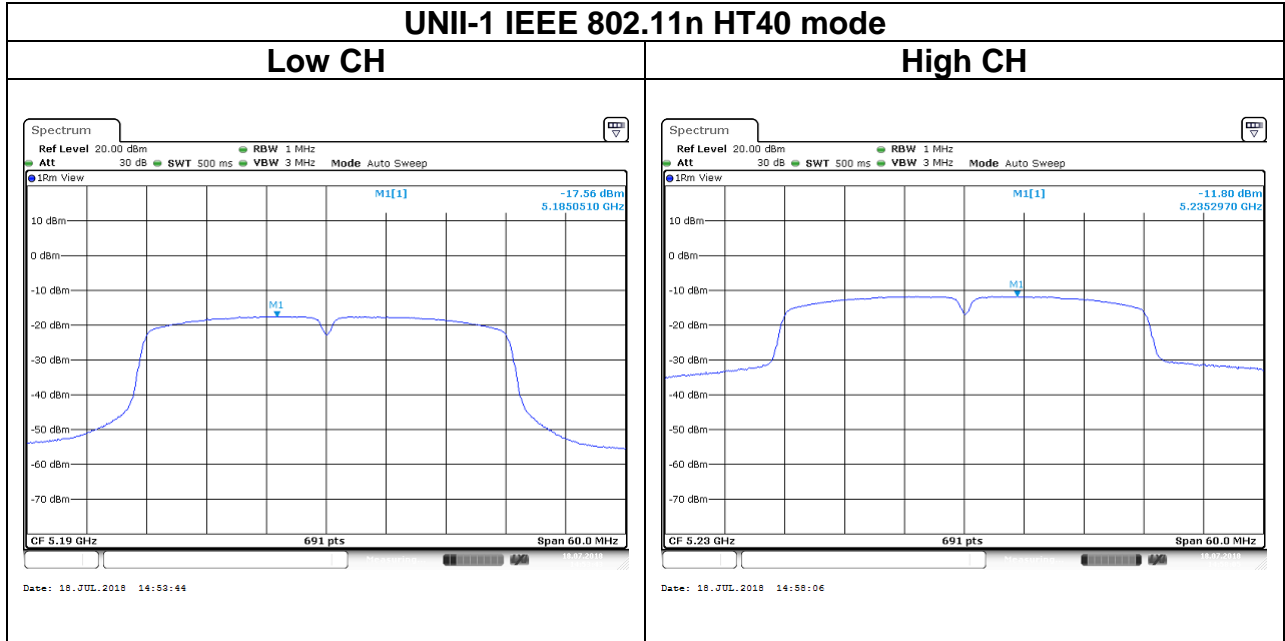

Report No.: T180627D11-RP4

Test Data

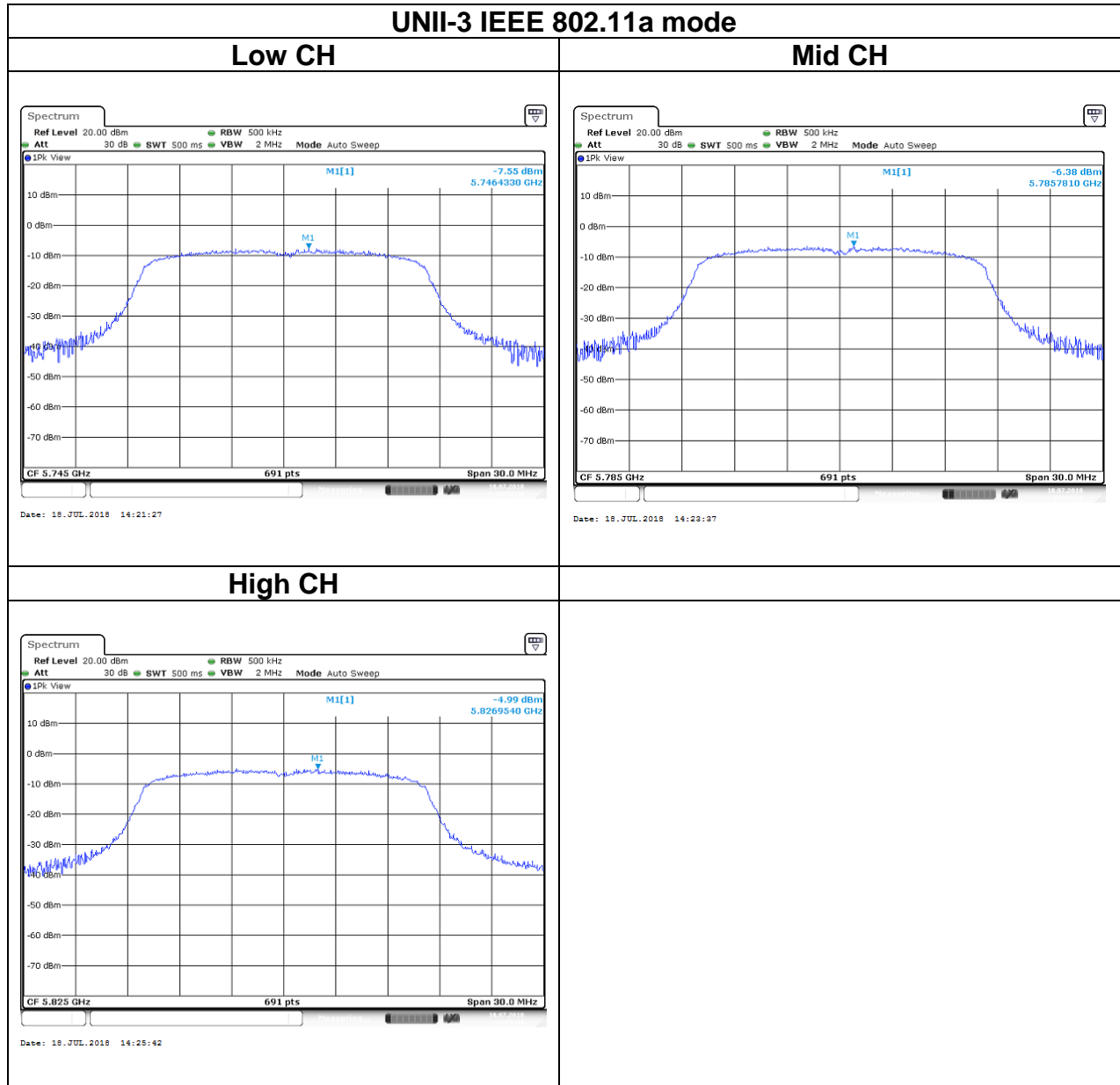

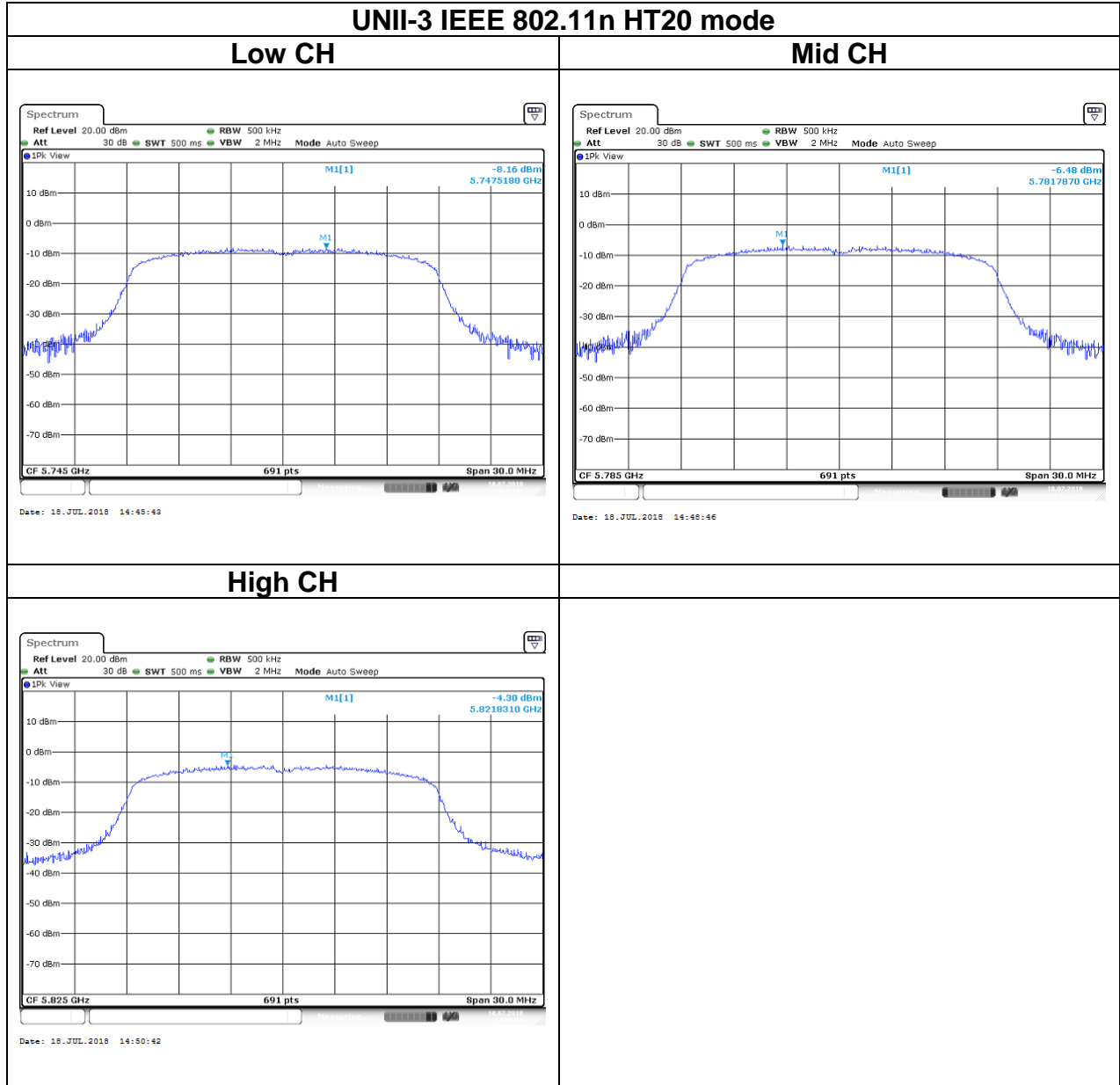

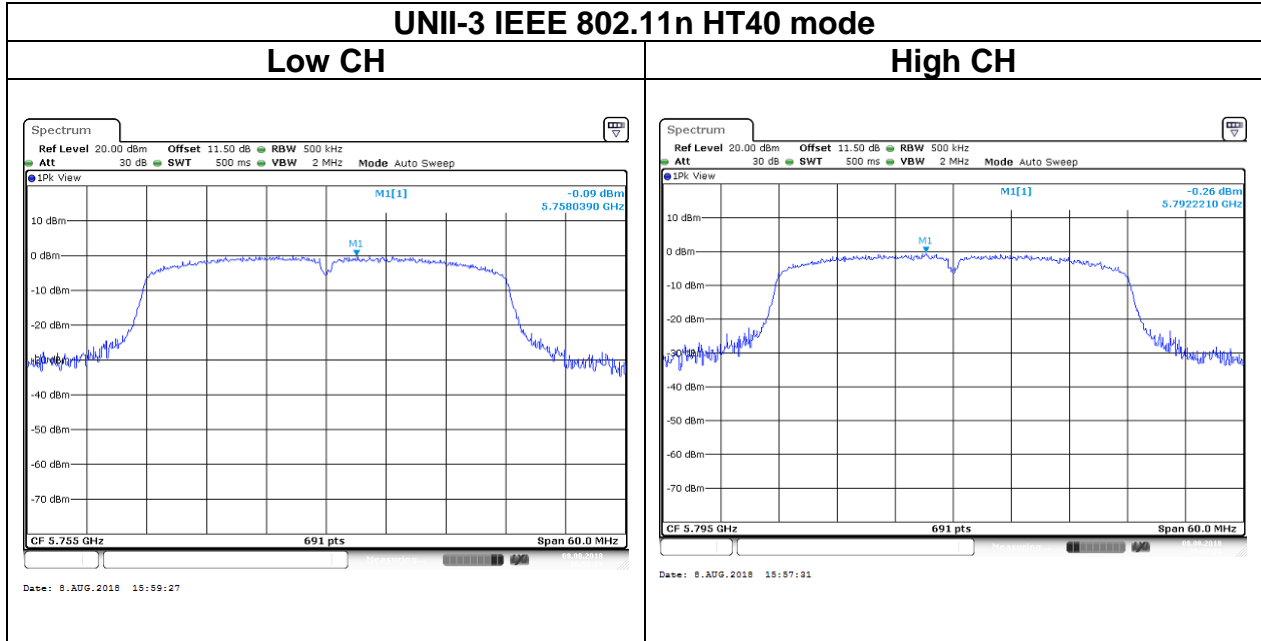

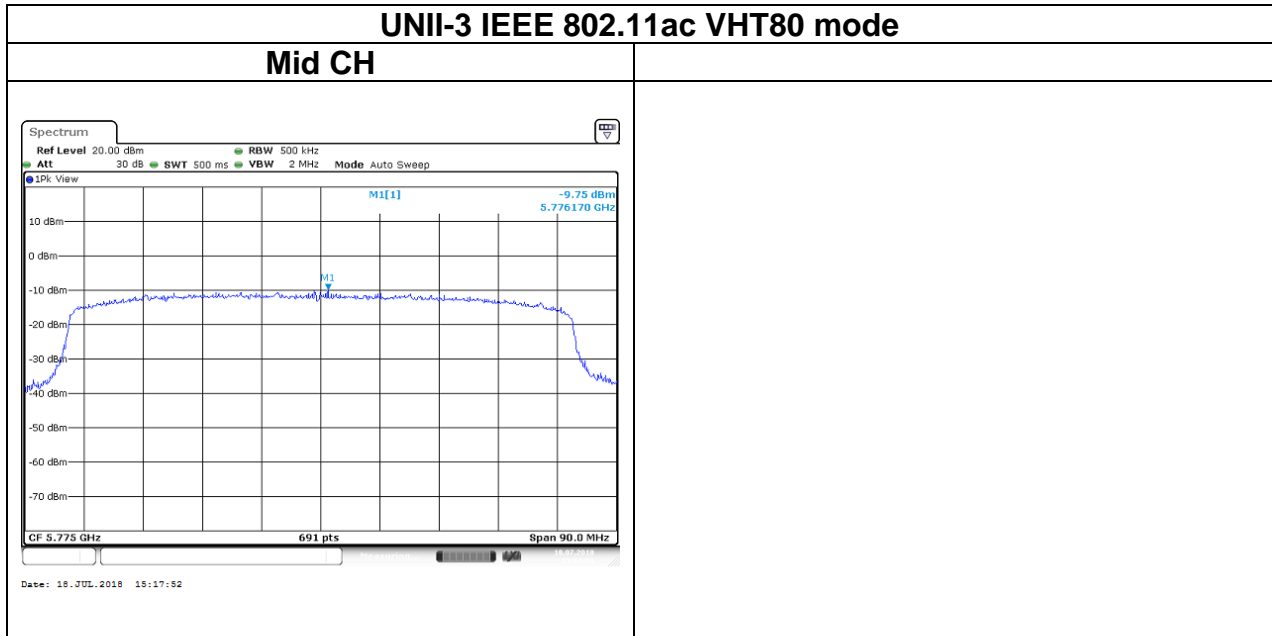

4.5 RADIATION BANDEDGE AND SPURIOUS EMISSION

4.5.1 Test Limit

FCC according to §15.407, §15.209 and §15.205,

Below 30 MHz

Frequency	Field Strength (microvolts/m)	Magnetic H-Field (microamperes/m)	Measurement Distance (metres)
9-490 kHz	2,400/F (F in kHz)	2,400/F (F in kHz)	300
490-1,705 kHz	24,000/F (F in kHz)	24,000/F (F in kHz)	30
1.705-30 MHz	30	N/A	30

Above 30 MHz

Frequency (MHz)	Field Strength microvolts/m at 3 metres (watts, e.i.r.p.)	
	Transmitters	Receivers
30-88	100 (3 nW)	100 (3 nW)
88-216	150 (6.8 nW)	150 (6.8 nW)
216-960	200 (12 nW)	200 (12 nW)
Above 960	500 (75 nW)	500 (75 nW)

UNII-1 :

For transmitters operating in the band 5150-5250 MHz, all emissions outside the band 5150-5350 MHz shall not exceed -27 dBm/MHz e.i.r.p. However, any unwanted emissions that fall into the band 5250-5350 MHz must be 26 dBc, when measured using a resolution bandwidth between 1 and 5% of the occupied bandwidth, above 5.25 GHz. Otherwise, the transmission is considered as intentional and the devices shall implement dynamic frequency selection (DFS) and transmitter power control (TPC) as per the requirements for the band 5250-5350 MHz

UNII-3:

All emissions shall be limited to a level of -27 dBm/MHz at 75 MHz or more above or below the band edge increasing linearly to 10 dBm/MHz at 25 MHz above or below the band edge, and from 25 MHz above or below the band edge increasing linearly to a level of 15.6 dBm/MHz at 5 MHz above or below the band edge, and from 5 MHz above or below the band edge increasing linearly to a level of 27 dBm/MHz at the band edge.

4.5.2 Test Procedure

Test method Refer as KDB 789033 D02, Section G.3, G.4, G.5, and G.6,.

1. The EUT is placed on a turntable, Above 1 GHz is 1.5m and below 1 GHz is 0.8m above ground plane. The EUT Configured un accordance with ANSI C63.10, and the EUT set in a continuous mode.
2. The turntable shall be rotated for 360 degrees to determine the position of maximum emission level. And EUT is set 3m away from the receiving antenna, which is scanned from 1m to 4m above the ground plane to find out the highest emissions. Measurement are made polarized in both the vertical and the horizontal positions with antenna.
3. Span shall wide enough to full capture the emission measured. The SA from 9kHz to 26.5GHz set to the low, Mid and High channels with the EUT transmit.

Remark:

1. Although these tests were performed other than open area test site, adequate comparison measurements were confirmed against 30 m open are test site. Therefore sufficient tests were made to demonstrate that the alternative site produces results that correlate with the ones of tests made in an open field based on KDB 414788.
2. No emission found between lowest internal used/generated frequency to 30MHz (9kHz~30MHz).

4. The SA setting following :

- (1) Below 1G : RBW = 100kHz, VBW $\geq 3 \cdot$ RBW, Sweep = Auto, Detector = Peak, Trace = Max hold.
- (2) Above 1G :
 - (2.1) For Peak measurement : RBW = 1MHz, VBW ≥ 3 RBW, Sweep = Auto, Detector = Peak, Trace = Max hold.
 - (2.2) For Average measurement : RBW = 1MHz, VBW
 - If Duty Cycle $\geq 98\%$, VBW=10Hz.
 - If Duty Cycle $< 98\%$, VBW=1/T.

Configuration	Duty Cycle (%)	T(ms)	1/T (Hz)	VBW Setting
802.11a	96.05%	1.4600	684.932	750Hz
802.11n HT20	96.45%	1.3600	735.294	750Hz
802.11n HT40	94.59%	0.7000	1428.571	1.5KHz
802.11ac VHT80	90.00%	0.3600	2777.778	3KHz

4.5.3 Test Setup

9kHz ~ 30MHz

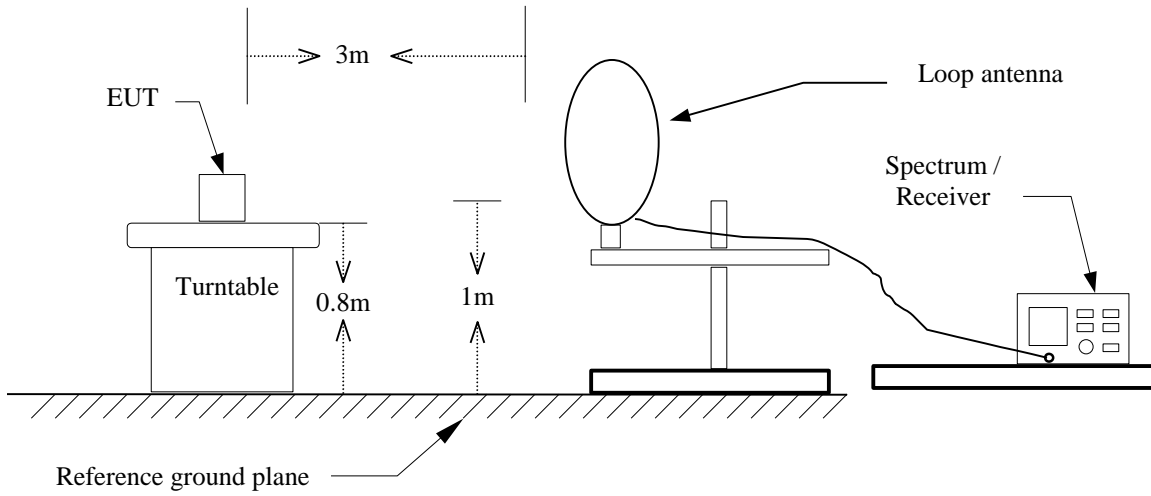

30MHz ~ 1GHz

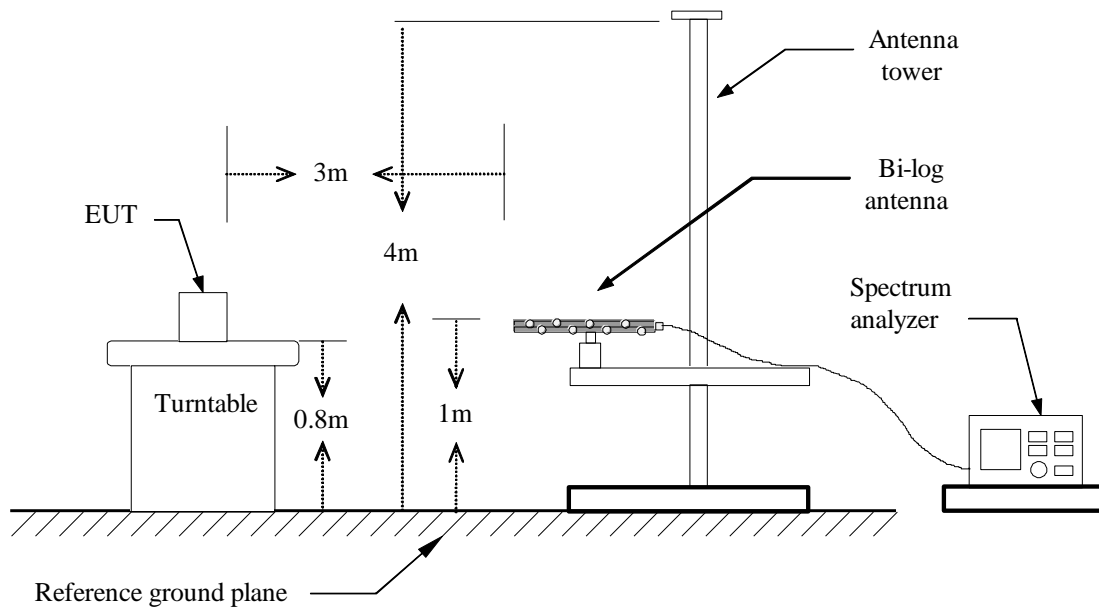

Above 1 GHz

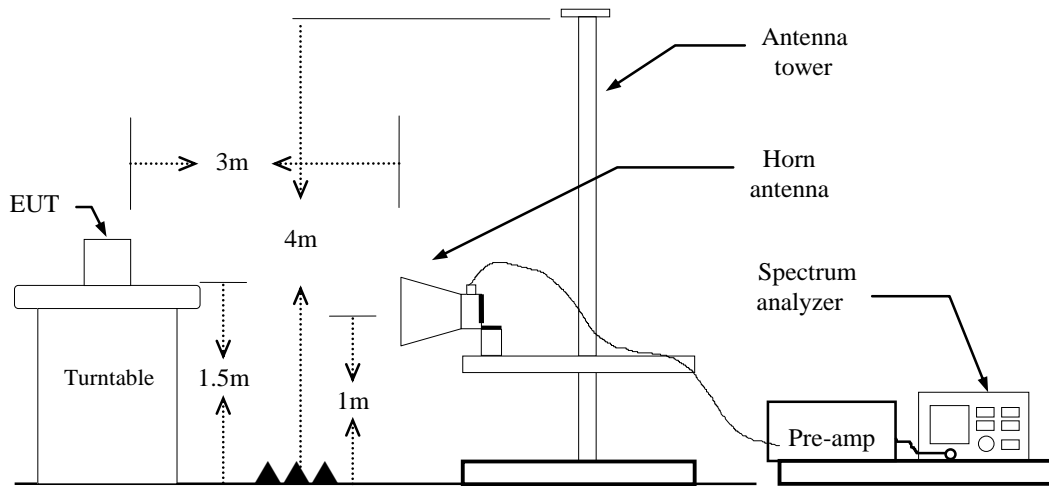

4.5.4 Test Result

Test Data

Band Edge Test Data for UNII-1

For PIFA Antenna

Test Mode	IEEE 802.11a / 5180MHZ	Temp/Hum	22(°C)/ 34%RH
Test Item	Band Edge	Test Date	July 17, 2018
Polarize	Vertical	Test Engineer	Jerry Chuang
Detector	Peak		

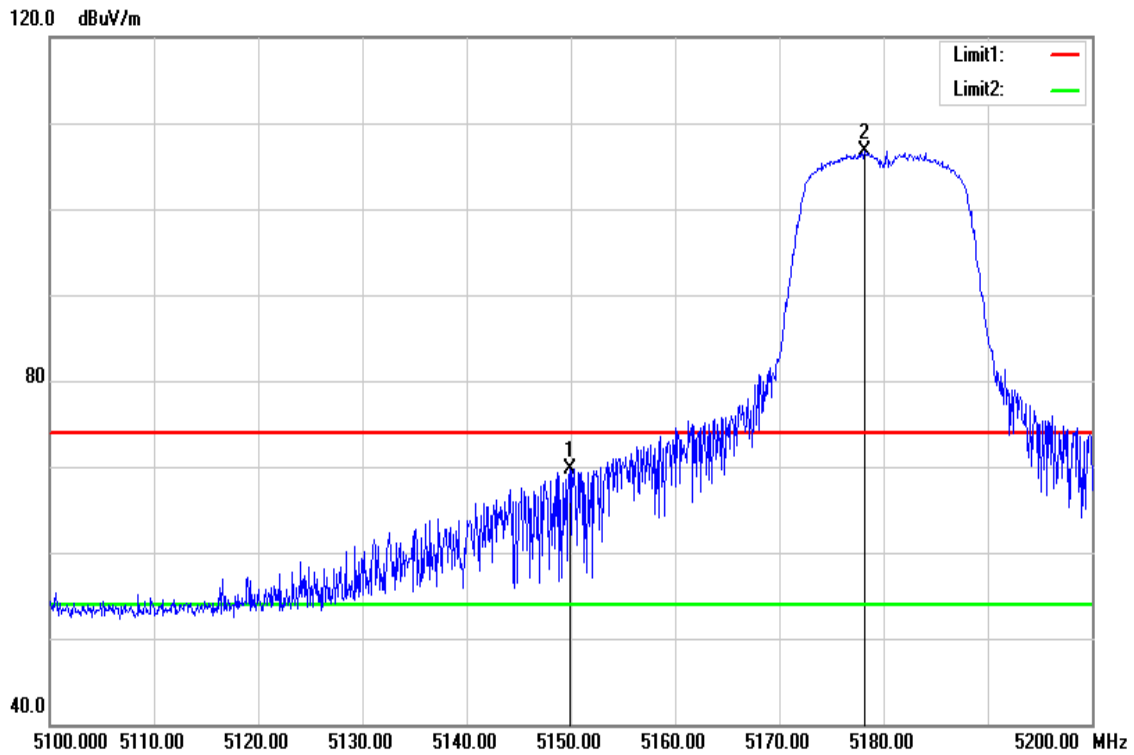

Frequency (MHz)	Reading (dBuV)	Correct Factor (dB/m)	Result (dBuV/m)	Limit (dBuV/m)	Margin (dB)	Remark
5149.900	64.66	5.06	69.72	74.00	-4.28	peak
5178.200	101.61	5.14	106.75	-	-	peak

Test Mode	IEEE 802.11a / 5180MHZ	Temperature	22(°C)/ 34%RH
Test Item	Band Edge	Test Date	July 17, 2018
Polarize	Vertical	Test Engineer	Jerry Chuang
Detector	Average		

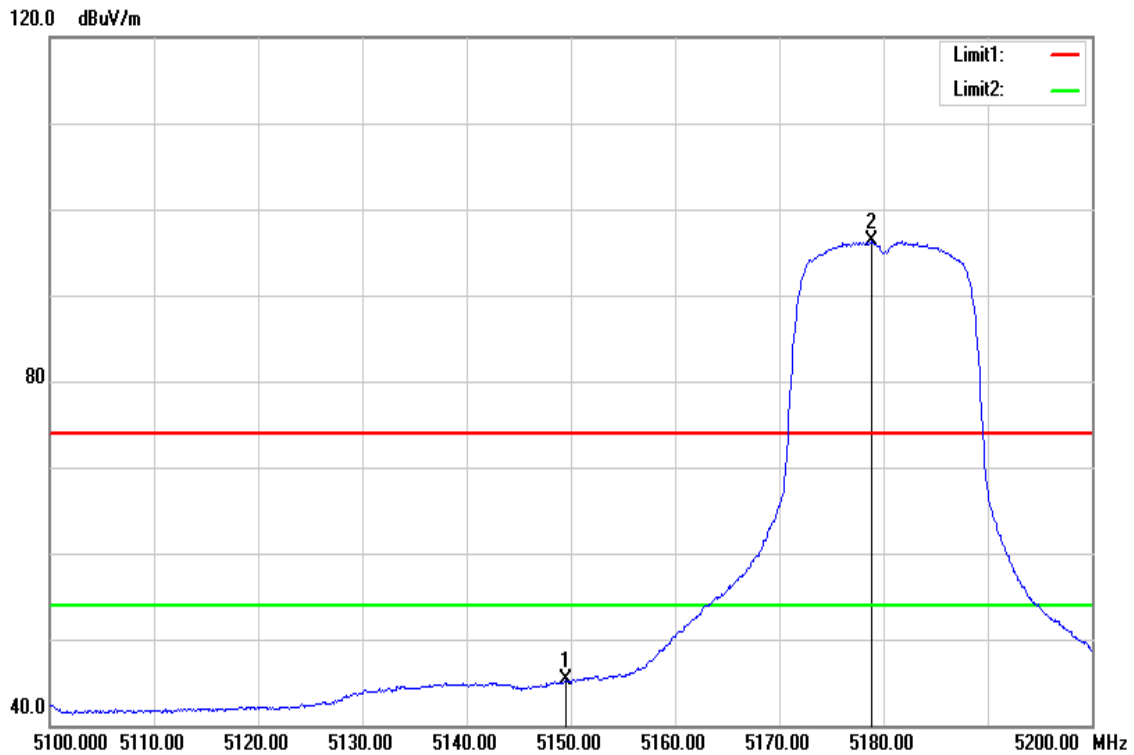

Frequency (MHz)	Reading (dBuV)	Correct Factor (dB/m)	Result (dBuV/m)	Limit (dBuV/m)	Margin (dB)	Remark
5149.500	40.16	5.06	45.22	54.00	-8.78	AVG
5178.900	91.13	5.14	96.27	-	-	AVG

Test Mode	IEEE 802.11a / 5240MHZ	Temp/Hum	22(°C)/ 34%RH
Test Item	Band Edge	Test Date	July 17, 2018
Polarize	Vertical	Test Engineer	Jerry Chuang
Detector	Peak		

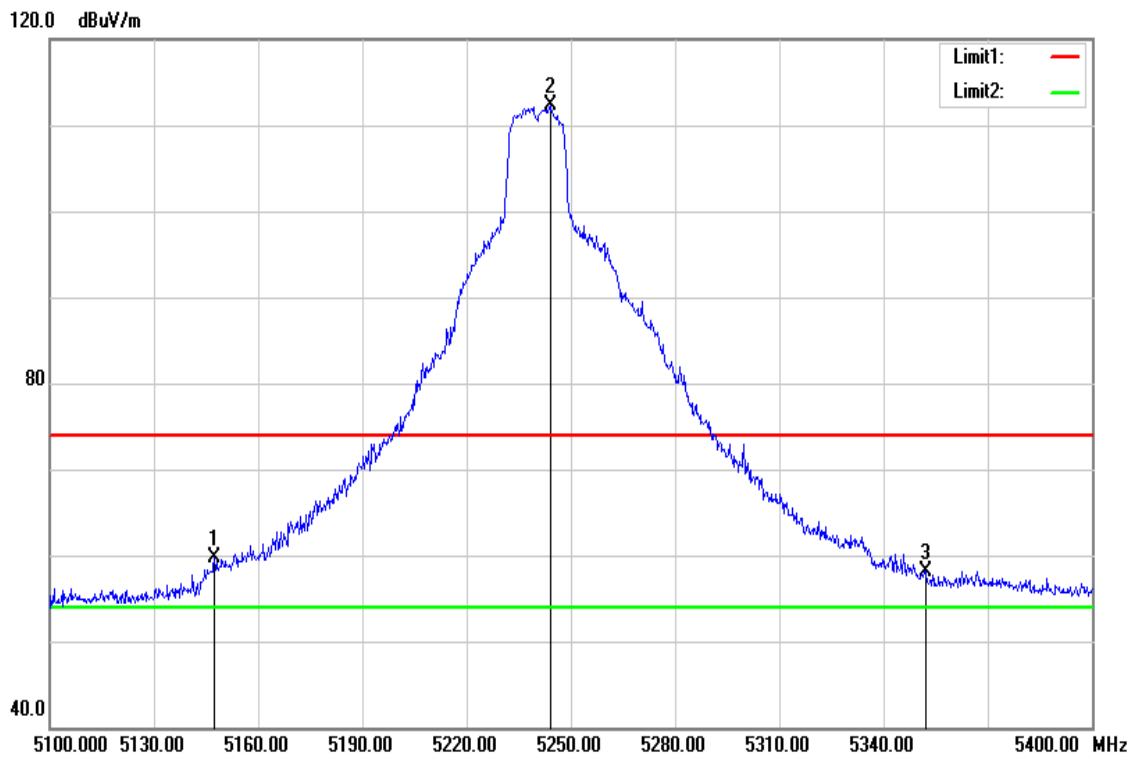

Frequency (MHz)	Reading (dBuV)	Correct Factor (dB/m)	Result (dBuV/m)	Limit (dBuV/m)	Margin (dB)	Remark
5147.400	54.58	5.06	59.64	74.00	-14.36	peak
5244.000	107.07	5.29	112.36	-	-	peak
5352.000	52.54	5.56	58.10	74.00	-15.90	peak

Test Mode	IEEE 802.11a / 5240MHZ	Temp/Hum	22(°C)/ 34%RH
Test Item	Band Edge	Test Date	July 17, 2018
Polarize	Vertical	Test Engineer	Jerry Chuang
Detector	Average		

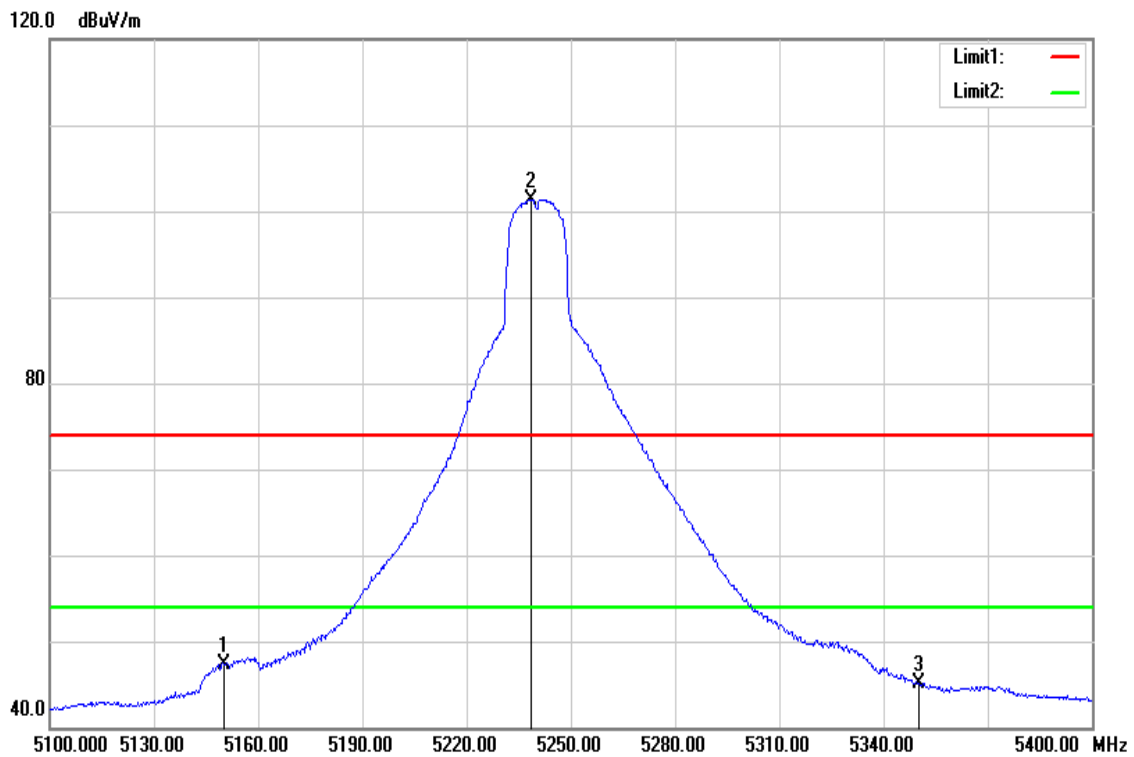

Frequency (MHz)	Reading (dBuV)	Correct Factor (dB/m)	Result (dBuV/m)	Limit (dBuV/m)	Margin (dB)	Remark
5150.000	42.28	5.06	47.34	54.00	-6.66	AVG
5238.600	96.08	5.28	101.36	-	-	AVG
5350.000	39.46	5.56	45.02	54.00	-8.98	AVG

Test Mode	IEEE 802.11n HT20 / 5180MHz	Temp/Hum	22(°C)/ 34%RH
Test Item	Band Edge	Test Date	July 17, 2018
Polarize	Vertical	Test Engineer	Jerry Chuang
Detector	Peak		

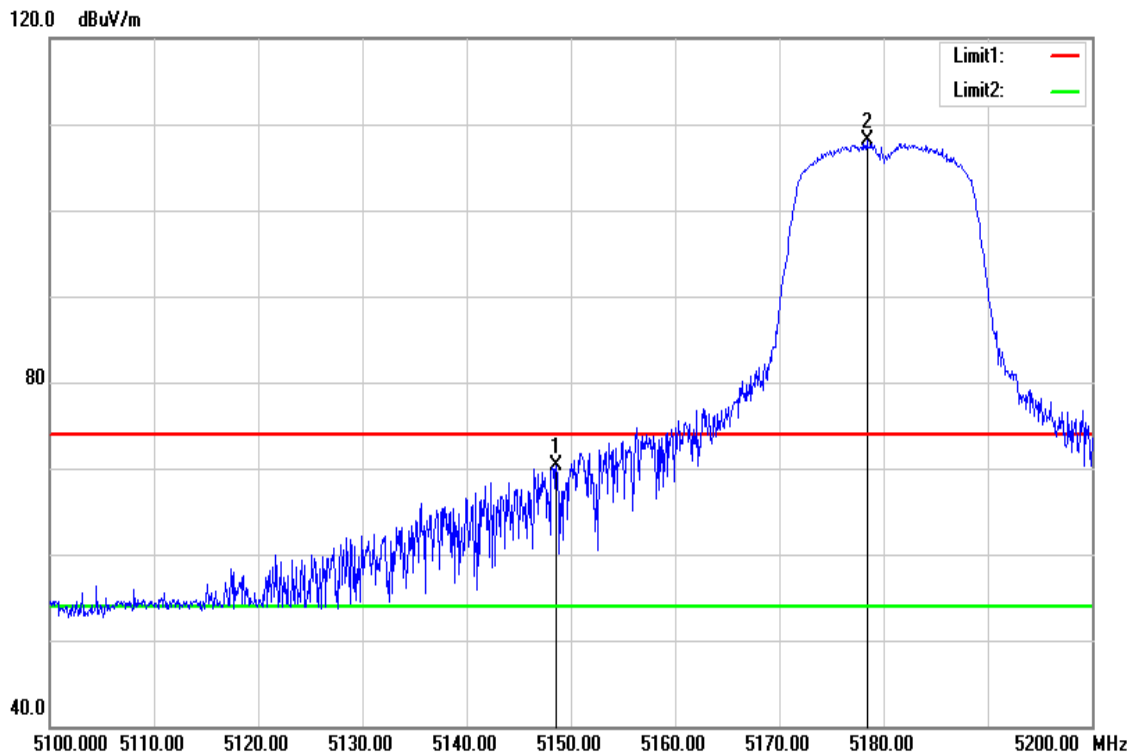

Frequency (MHz)	Reading (dBuV)	Correct Factor (dB/m)	Result (dBuV/m)	Limit (dBuV/m)	Margin (dB)	Remark
5148.600	65.26	5.06	70.32	74.00	-3.68	peak
5178.400	103.06	5.14	108.20	-	-	peak

Test Mode	IEEE 802.11n HT20 / 5180MHZ	Temp/Hum	22(°C)/ 34%RH
Test Item	Band Edge	Test Date	July 17, 2018
Polarize	Vertical	Test Engineer	Jerry Chuang
Detector	Average		

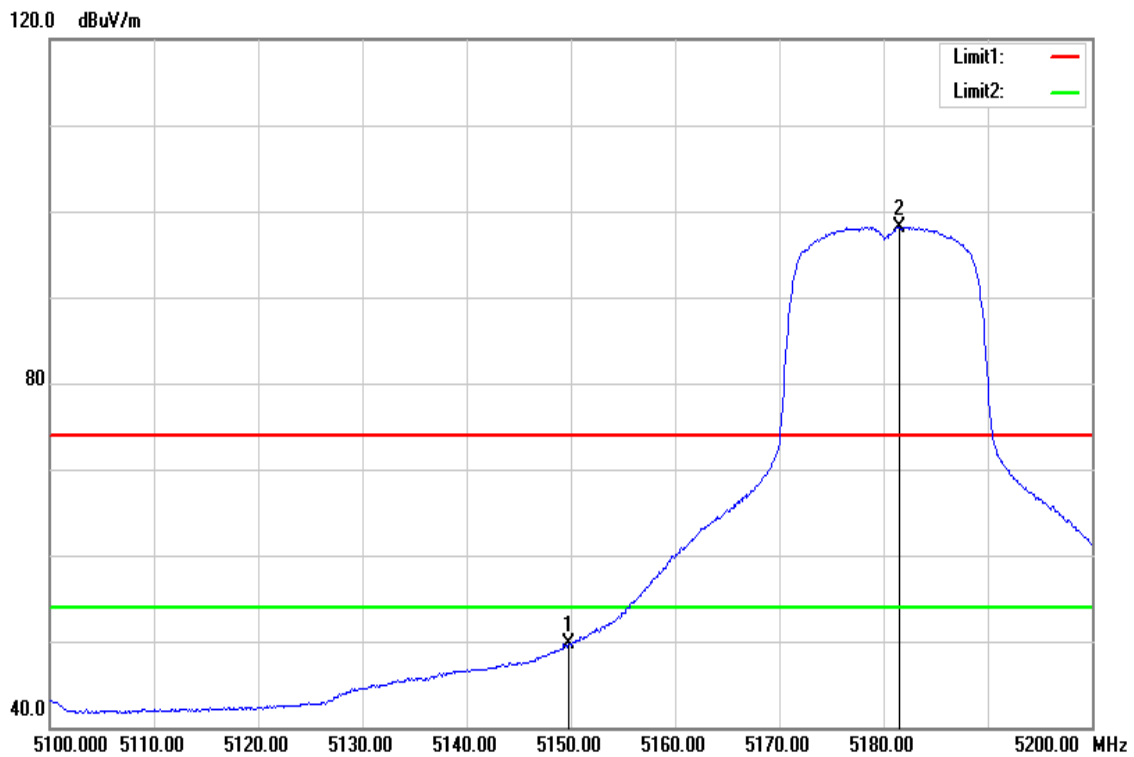

Frequency (MHz)	Reading (dBuV)	Correct Factor (dB/m)	Result (dBuV/m)	Limit (dBuV/m)	Margin (dB)	Remark
5149.800	44.62	5.06	49.68	54.00	-4.32	AVG
5181.500	93.05	5.14	98.19	-	-	AVG

Test Mode	IEEE 802.11n HT20 / 5240MHZ	Temp/Hum	22(°C)/ 34%RH
Test Item	Band Edge	Test Date	July 17, 2018
Polarize	Vertical	Test Engineer	Jerry Chuang
Detector	Peak		

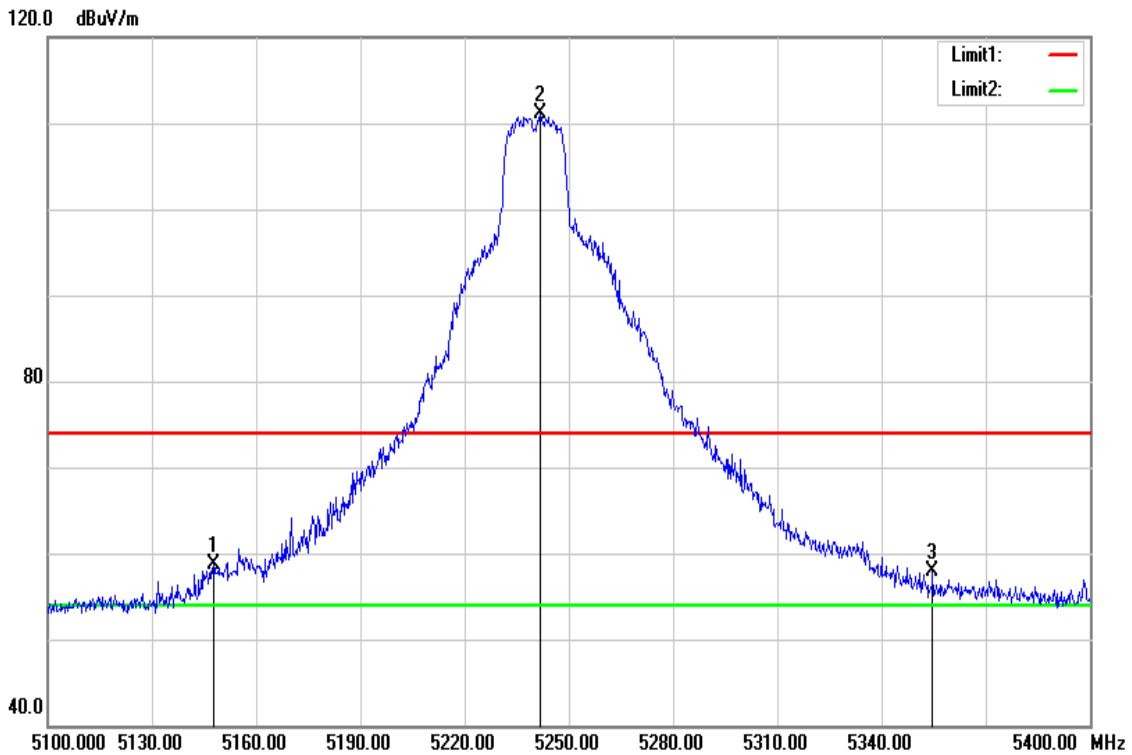

Frequency (MHz)	Reading (dBuV)	Correct Factor (dB/m)	Result (dBuV/m)	Limit (dBuV/m)	Margin (dB)	Remark
5147.700	53.73	5.06	58.79	74.00	-15.21	peak
5241.600	105.77	5.28	111.05	-	-	peak
5354.700	52.29	5.56	57.85	74.00	-16.15	peak

Test Mode	IEEE 802.11n HT20 / 5240MHZ	Temperature	22(°C)/ 34%RH
Test Item	Band Edge	Test Date	July 17, 2018
Polarize	Vertical	Test Engineer	Jerry Chuang
Detector	Average		

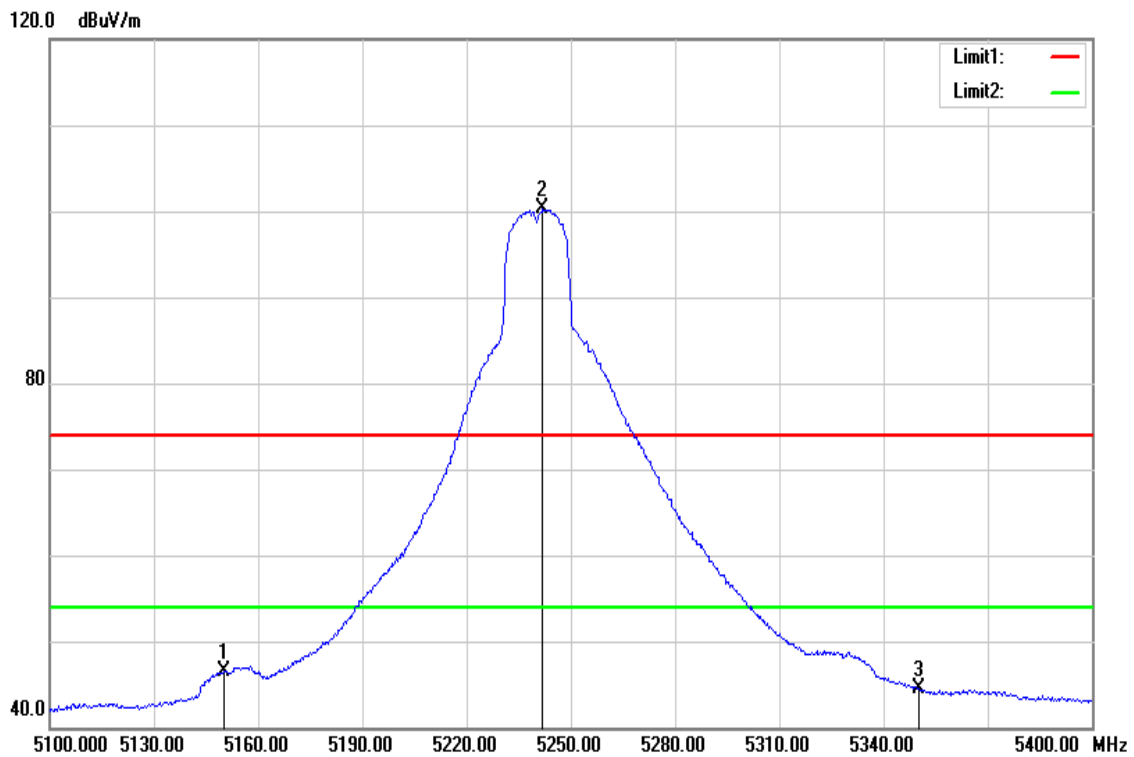

Frequency (MHz)	Reading (dBuV)	Correct Factor (dB/m)	Result (dBuV/m)	Limit (dBuV/m)	Margin (dB)	Remark
5150.000	41.37	5.06	46.43	54.00	-7.57	AVG
5241.900	94.93	5.29	100.22	-	-	AVG
5350.000	38.99	5.56	44.55	54.00	-9.45	AVG

Test Mode	IEEE 802.11n HT40 / 5190MHZ	Temp/Hum	22(°C)/ 34%RH
Test Item	Band Edge	Test Date	July 17, 2018
Polarize	Vertical	Test Engineer	Jerry Chuang
Detector	Peak		

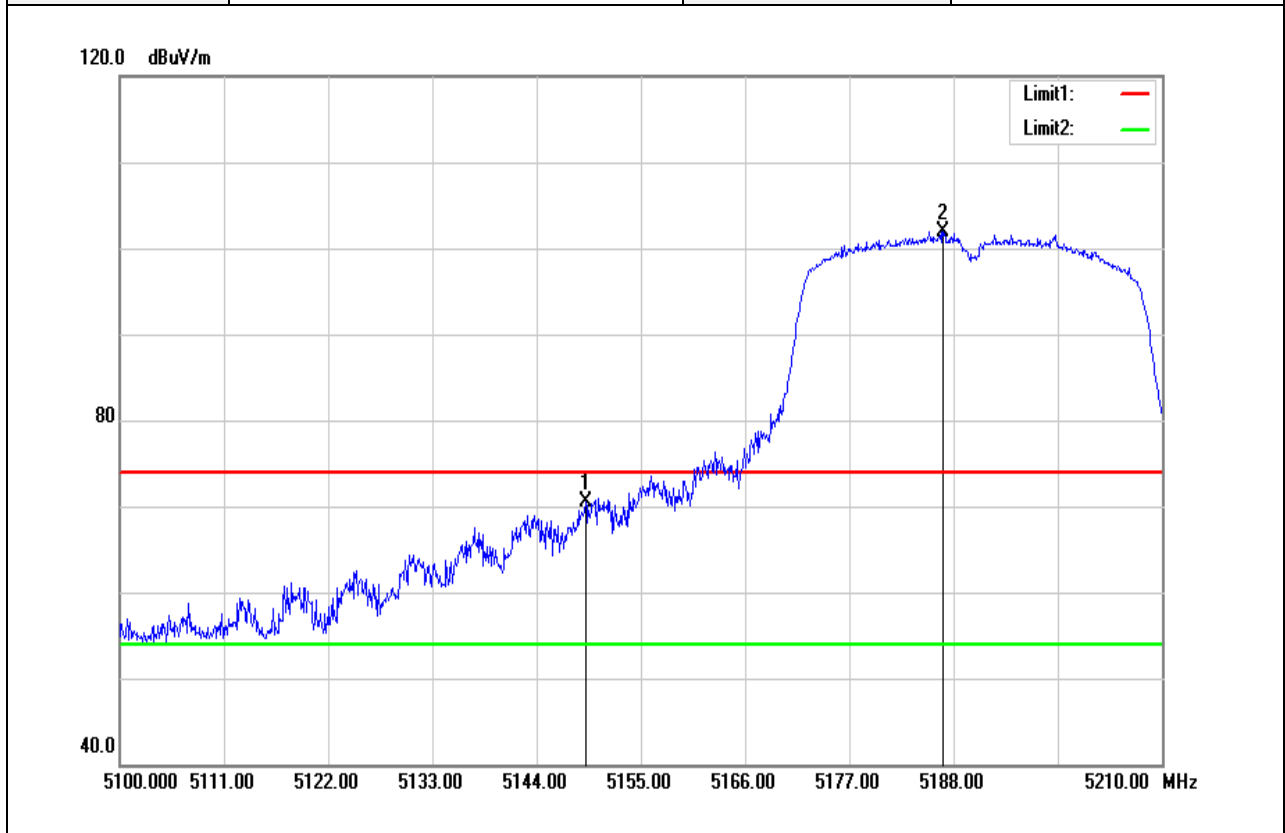

Frequency (MHz)	Reading (dBuV)	Correct Factor (dB/m)	Result (dBuV/m)	Limit (dBuV/m)	Margin (dB)	Remark
5149.170	65.48	5.06	70.54	74.00	-3.46	peak
5186.900	96.71	5.15	101.86	-	-	peak

Test Mode	IEEE 802.11n HT40 / 5190MHZ	Temperature	22(°C)/ 34%RH
Test Item	Band Edge	Test Date	July 17, 2018
Polarize	Vertical	Test Engineer	Jerry Chuang
Detector	Average		

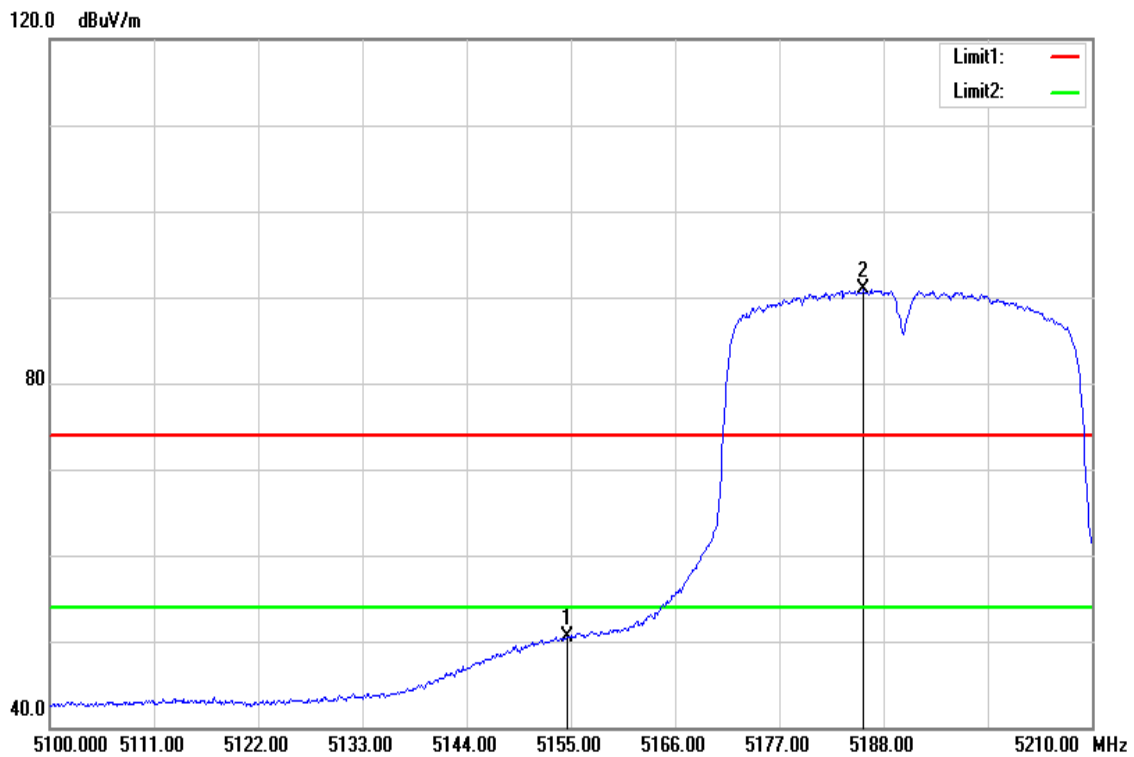

Frequency (MHz)	Reading (dBuV)	Correct Factor (dB/m)	Result (dBuV/m)	Limit (dBuV/m)	Margin (dB)	Remark
5154.560	45.45	5.07	50.52	54.00	-3.48	AVG
5185.910	85.71	5.15	90.86	-	-	AVG

Test Mode	IEEE 802.11n HT40 / 5230MHZ	Temp/Hum	22(°C)/ 34%RH
Test Item	Band Edge	Test Date	July 17, 2018
Polarize	Vertical	Test Engineer	Jerry Chuang
Detector	Peak		

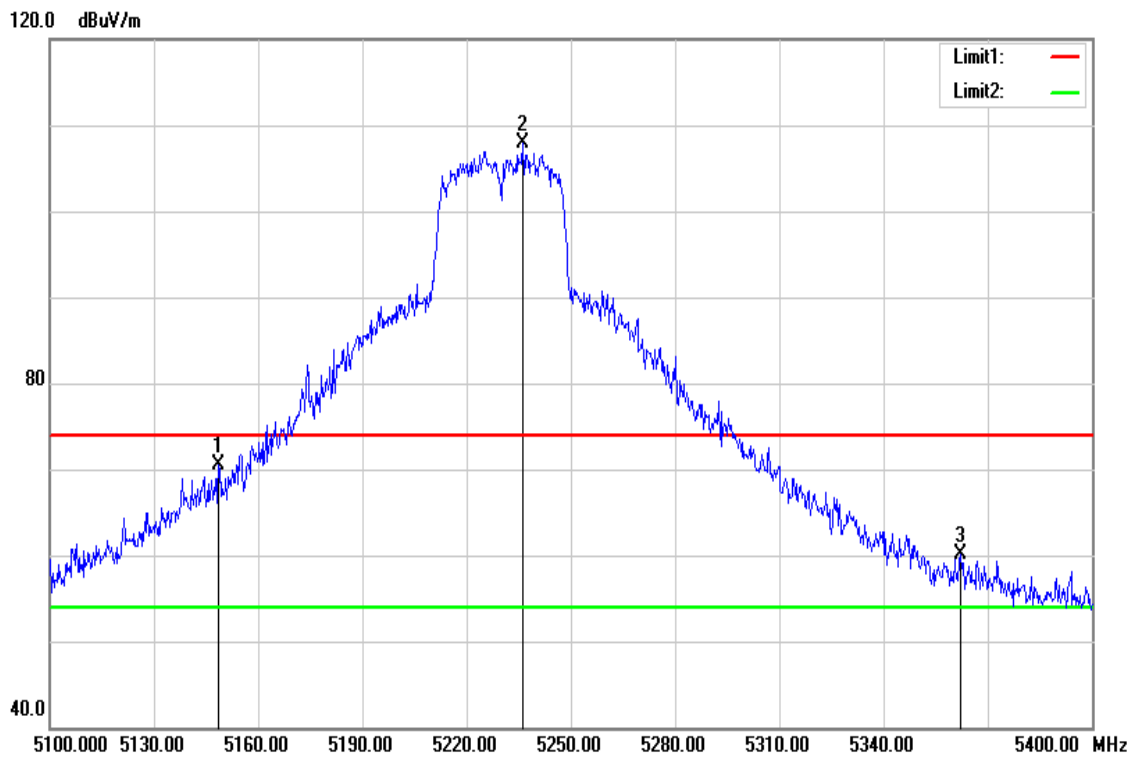

Frequency (MHz)	Reading (dBuV)	Correct Factor (dB/m)	Result (dBuV/m)	Limit (dBuV/m)	Margin (dB)	Remark
5148.600	65.47	5.06	70.53	74.00	-3.47	peak
5236.200	102.58	5.28	107.86	-	-	peak
5362.200	54.45	5.59	60.04	74.00	-13.96	peak

Test Mode	IEEE 802.11n HT40 / 5230MHZ	Temp/Hum	22(°C)/ 34%RH
Test Item	Band Edge	Test Date	July 17, 2018
Polarize	Vertical	Test Engineer	Jerry Chuang
Detector	Average		

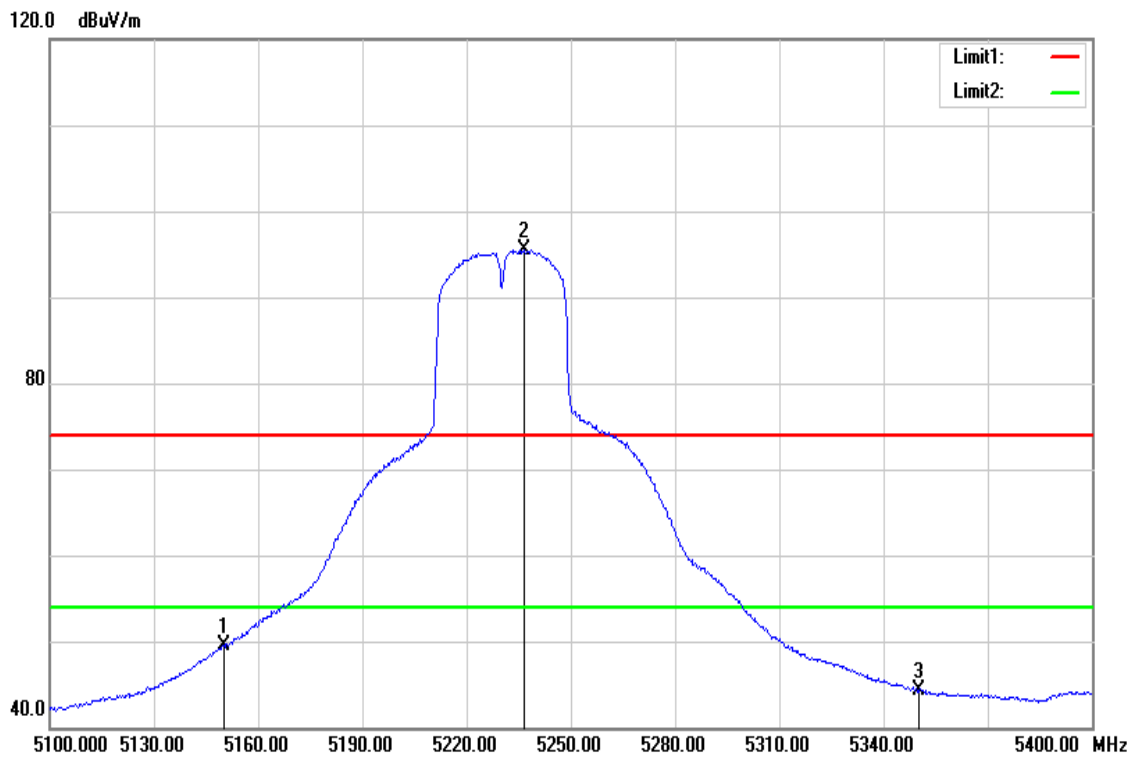

Frequency (MHz)	Reading (dBuV)	Correct Factor (dB/m)	Result (dBuV/m)	Limit (dBuV/m)	Margin (dB)	Remark
5150.000	44.44	5.06	49.50	54.00	-4.50	AVG
5236.500	90.19	5.28	95.47	-	-	AVG
5350.000	38.64	5.56	44.20	54.00	-9.80	AVG

Test Mode	I EEE 802.11ac VHT80 / 5210MHZ	Temp/Hum	22(°C)/ 34%RH
Test Item	Band Edge	Test Date	July 17, 2018
Polarize	Vertical	Test Engineer	Jerry Chuang
Detector	Peak		

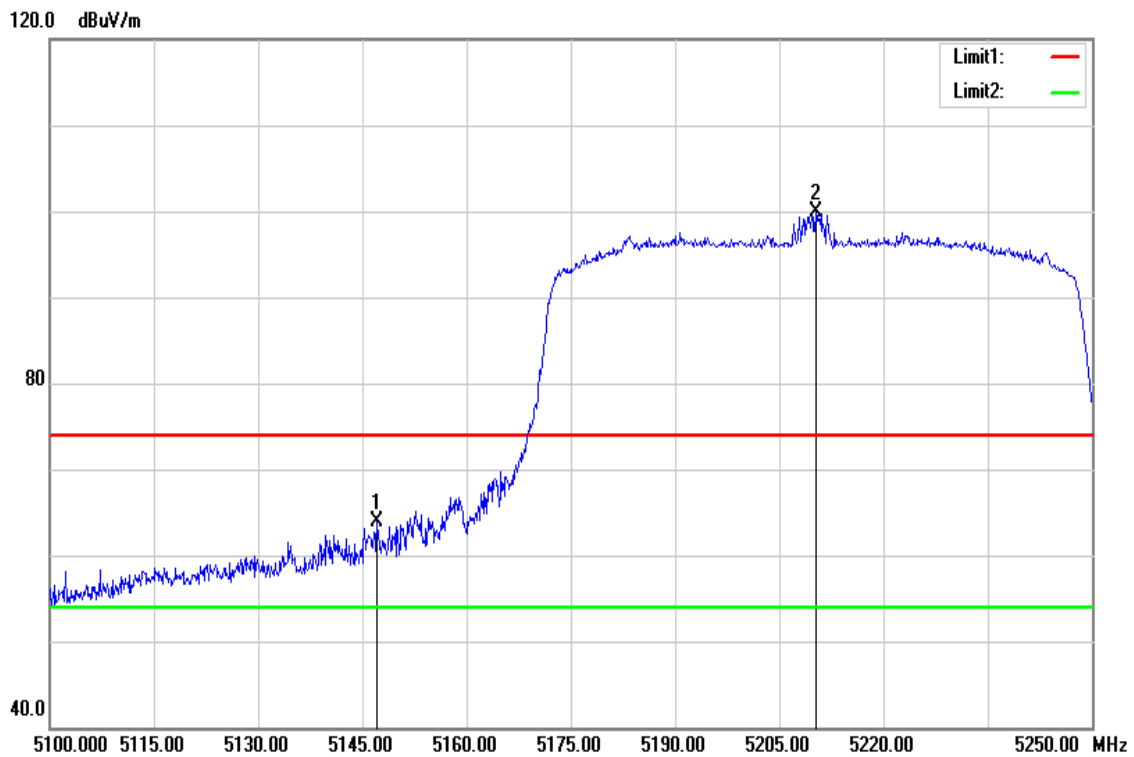

Frequency (MHz)	Reading (dBuV)	Correct Factor (dB/m)	Result (dBuV/m)	Limit (dBuV/m)	Margin (dB)	Remark
5147.100	58.88	5.06	63.94	74.00	-10.06	peak
5210.250	94.62	5.22	99.84	-	-	peak

Report No.: T180627D11-RP4

Test Mode	I EEE 802.11ac VHT80 / 5210MHZ	Temp/Hum	22(°C)/ 34%RH
Test Item	Band Edge	Test Date	July 17, 2018
Polarize	Vertical	Test Engineer	Jerry Chuang
Detector	Average		

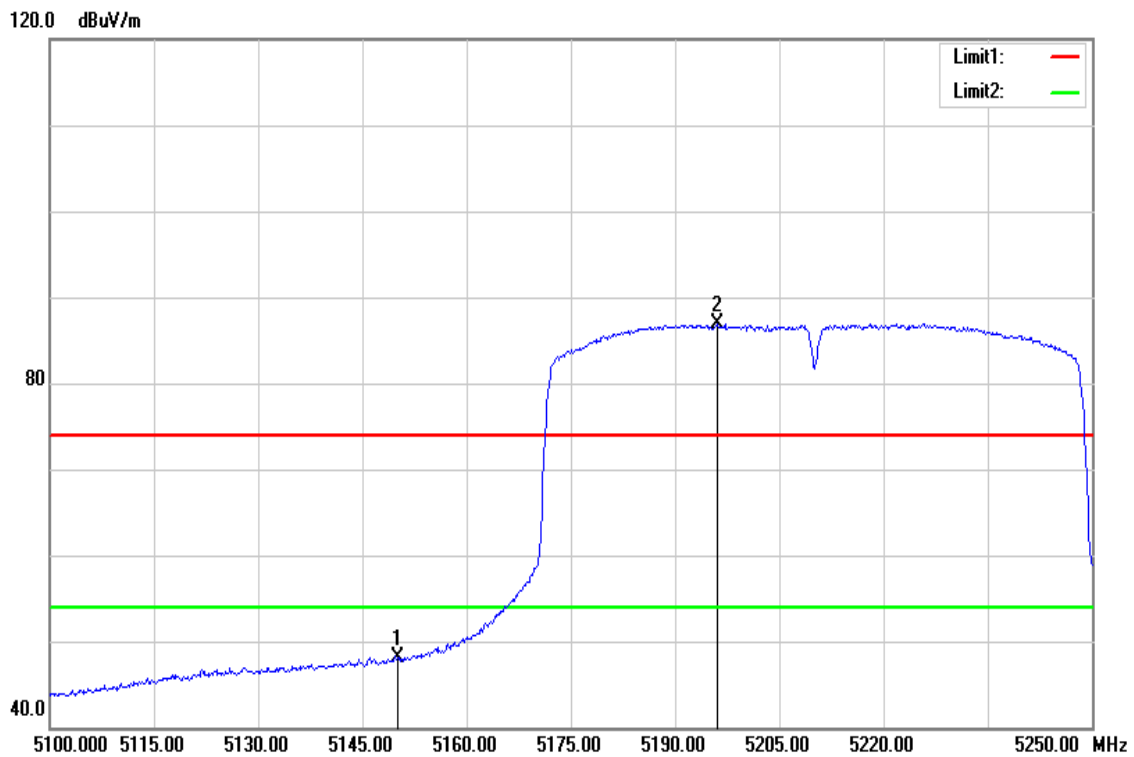

Frequency (MHz)	Reading (dBuV)	Correct Factor (dB/m)	Result (dBuV/m)	Limit (dBuV/m)	Margin (dB)	Remark
5150.000	42.99	5.06	48.05	54.00	-5.95	AVG
5196.150	81.70	5.18	86.88	-	-	AVG

Band Edge Test Data for UNII-3

Test Mode	IEEE 802.11a / 5745 MHz	Temp/Hum	22(°C)/ 34%RH
Test Item	Band Edge	Test Date	July 17, 2018
Polarize	Vertical	Test Engineer	Jerry Chuang
Detector	Peak		

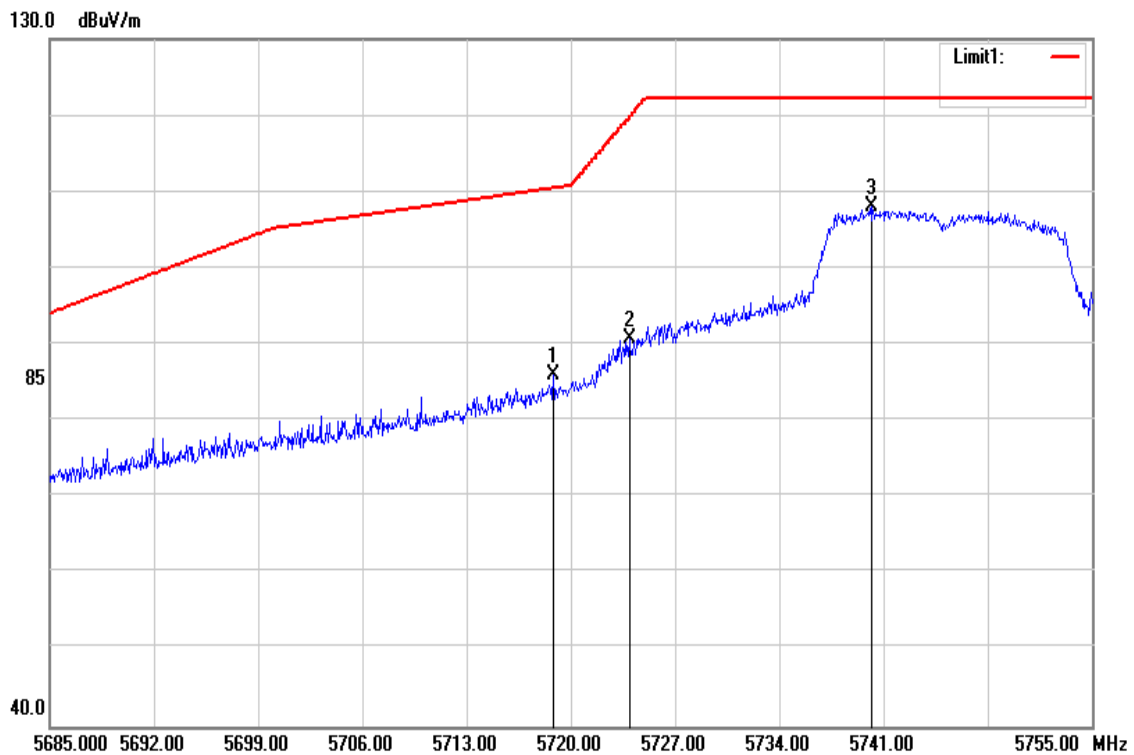

Frequency (MHz)	Reading (dBuV)	Correct Factor (dB/m)	Result (dBuV/m)	Limit (dBuV/m)	Margin (dB)	Remark
5718.810	79.62	6.50	86.12	110.47	-24.35	peak
5723.920	84.28	6.52	90.80	119.74	-28.94	peak
5740.230	101.41	6.56	107.97	-	-	peak

Test Mode	IEEE 802.11a / 5745 MHz	Temp/Hum	22(°C)/ 34%RH
Test Item	Band Edge	Test Date	July 17, 2018
Polarize	Vertical	Test Engineer	Jerry Chuang
Detector	Average		

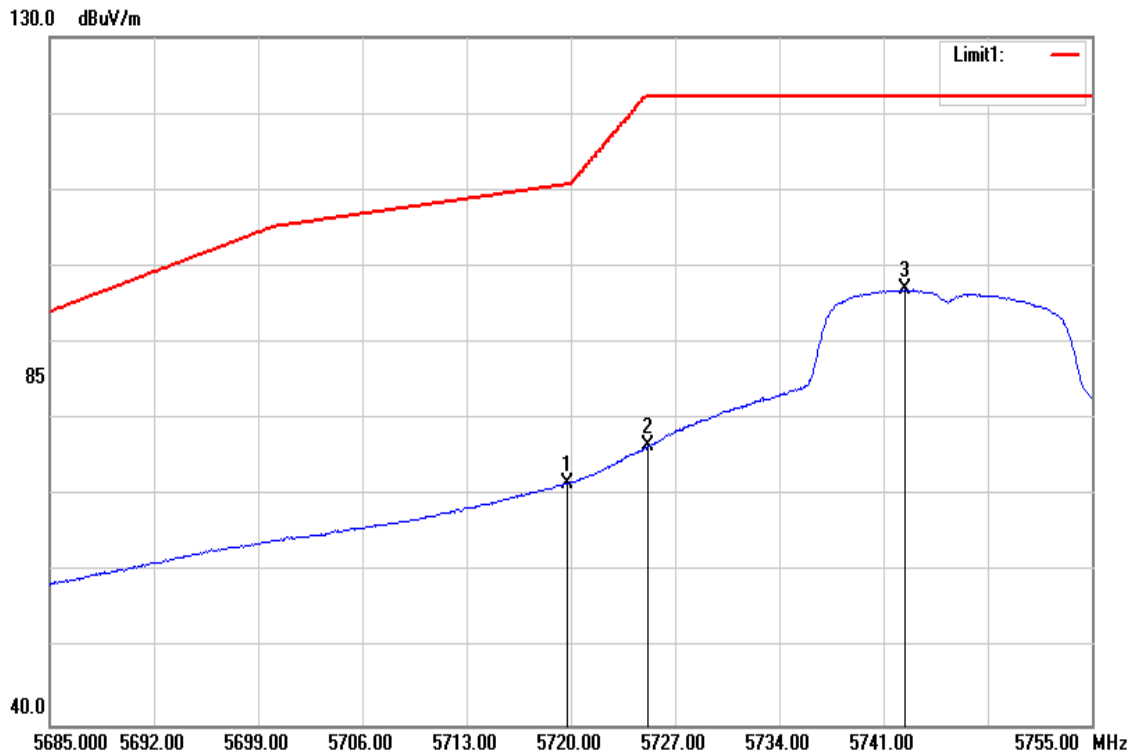

Frequency (MHz)	Reading (dBuV)	Correct Factor (dB/m)	Result (dBuV/m)	Limit (dBuV/m)	Margin (dB)	Remark
5719.790	65.21	6.50	71.71	110.74	-39.03	AVG
5725.180	69.96	6.52	76.48	122.20	-45.72	AVG
5742.400	90.48	6.56	97.04	-	-	AVG

Test Mode	IEEE 802.11a / 5825 MHz	Temp/Hum	22(°C)/ 34%RH
Test Item	Band Edge	Test Date	July 17, 2018
Polarize	Vertical	Test Engineer	Jerry Chuang
Detector	Peak		

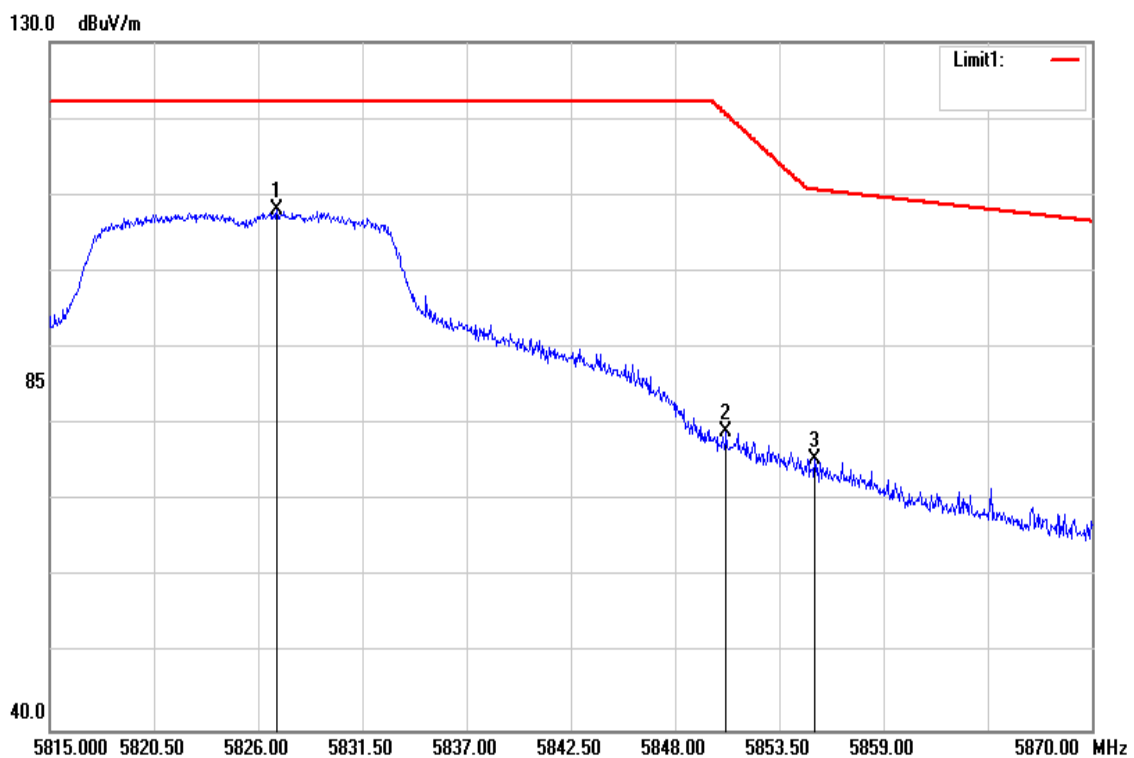

Frequency (MHz)	Reading (dBuV)	Correct Factor (dB/m)	Result (dBuV/m)	Limit (dBuV/m)	Margin (dB)	Remark
5826.990	101.20	6.78	107.98	-	-	peak
5850.695	72.12	6.85	78.97	120.62	-41.65	peak
5855.370	68.55	6.86	75.41	110.70	-35.29	peak

Test Mode	IEEE 802.11a / 5825 MHz	Temp/Hum	22(°C)/ 34%RH
Test Item	Band Edge	Test Date	July 17, 2018
Polarize	Vertical	Test Engineer	Jerry Chuang
Detector	Average		

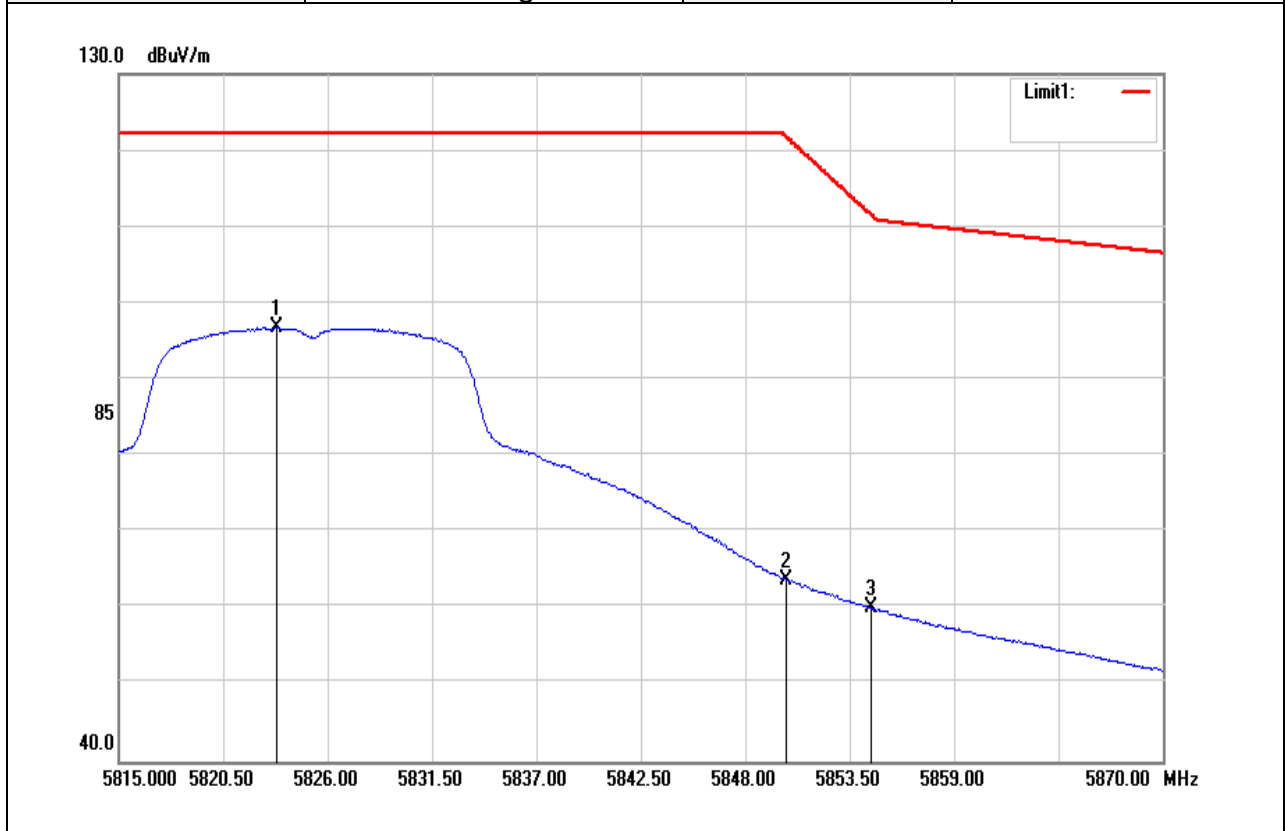

Frequency (MHz)	Reading (dBuV)	Correct Factor (dB/m)	Result (dBuV/m)	Limit (dBuV/m)	Margin (dB)	Remark
5823.305	90.03	6.78	96.81	-	-	AVG
5850.145	56.91	6.85	63.76	121.87	-58.11	AVG
5854.600	53.27	6.86	60.13	111.71	-51.58	AVG

Report No.: T180627D11-RP4

Test Mode	IEEE 802.11n HT20 / 5745 MHz	Temp/Hum	22(°C)/ 34%RH
Test Item	Band Edge	Test Date	July 17, 2018
Polarize	Vertical	Test Engineer	Jerry Chuang
Detector	Peak		

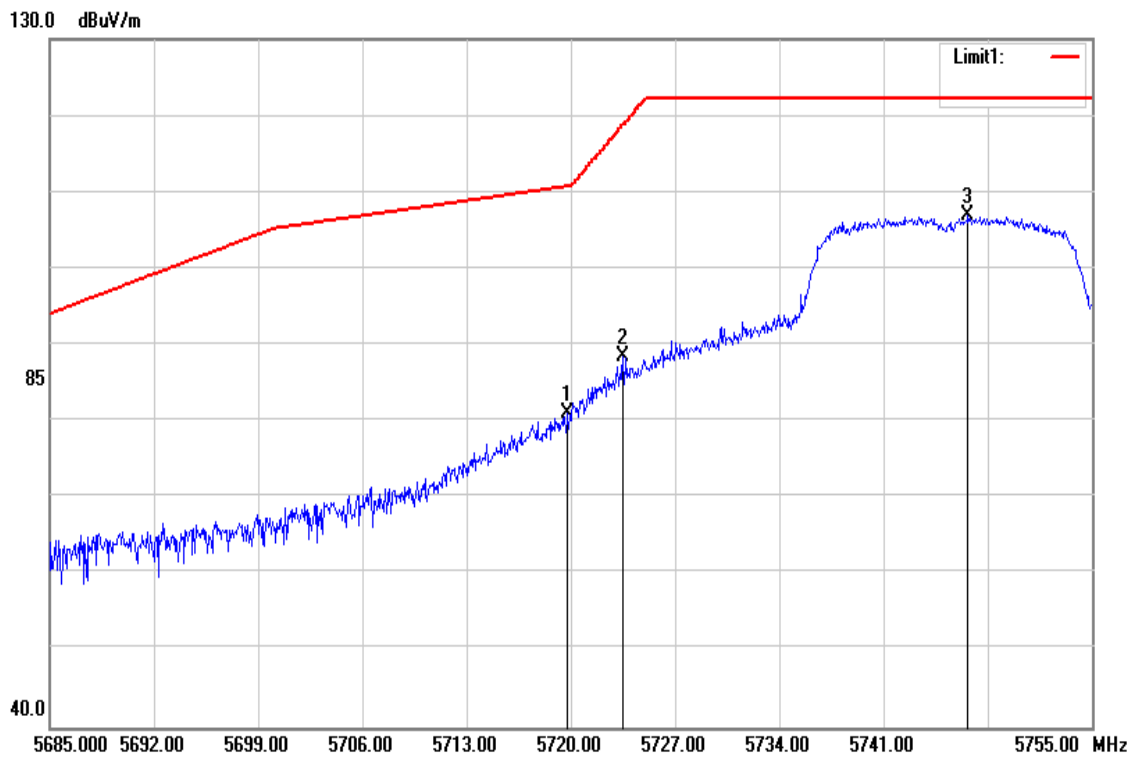

Frequency (MHz)	Reading (dBuV)	Correct Factor (dB/m)	Result (dBuV/m)	Limit (dBuV/m)	Margin (dB)	Remark
5719.790	74.47	6.50	80.97	110.74	-29.77	peak
5723.500	82.03	6.52	88.55	118.78	-30.23	peak
5746.670	100.26	6.58	106.84	-	-	peak

Test Mode	IEEE 802.11n HT20 / 5745 MHz	Temp/Hum	22(°C)/ 34%RH
Test Item	Band Edge	Test Date	July 17, 2018
Polarize	Vertical	Test Engineer	Jerry Chuang
Detector	Average		

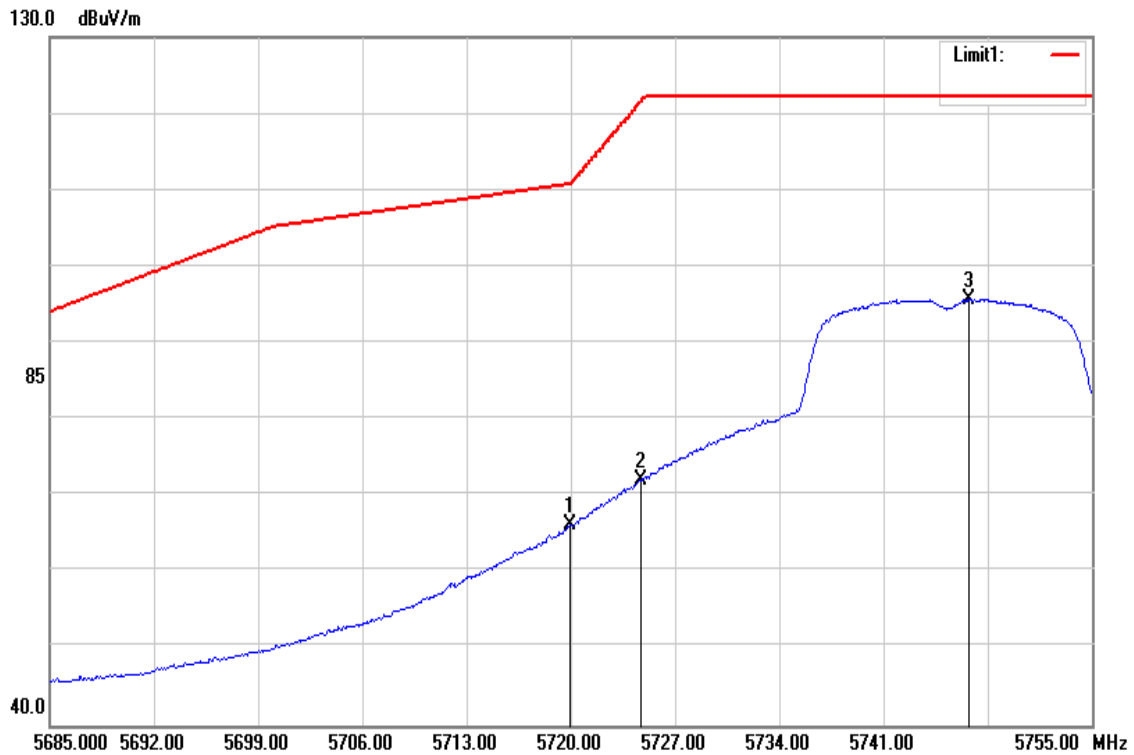

Frequency (MHz)	Reading (dBuV)	Correct Factor (dB/m)	Result (dBuV/m)	Limit (dBuV/m)	Margin (dB)	Remark
5719.930	59.64	6.50	66.14	110.78	-44.64	AVG
5724.690	65.54	6.52	72.06	121.49	-49.43	AVG
5746.740	89.11	6.58	95.69	-	-	AVG

Test Mode	IEEE 802.11n HT20 / 5825 MHz	Temp/Hum	22(°C)/ 34%RH
Test Item	Band Edge	Test Date	July 17, 2018
Polarize	Vertical	Test Engineer	Jerry Chuang
Detector	Peak		

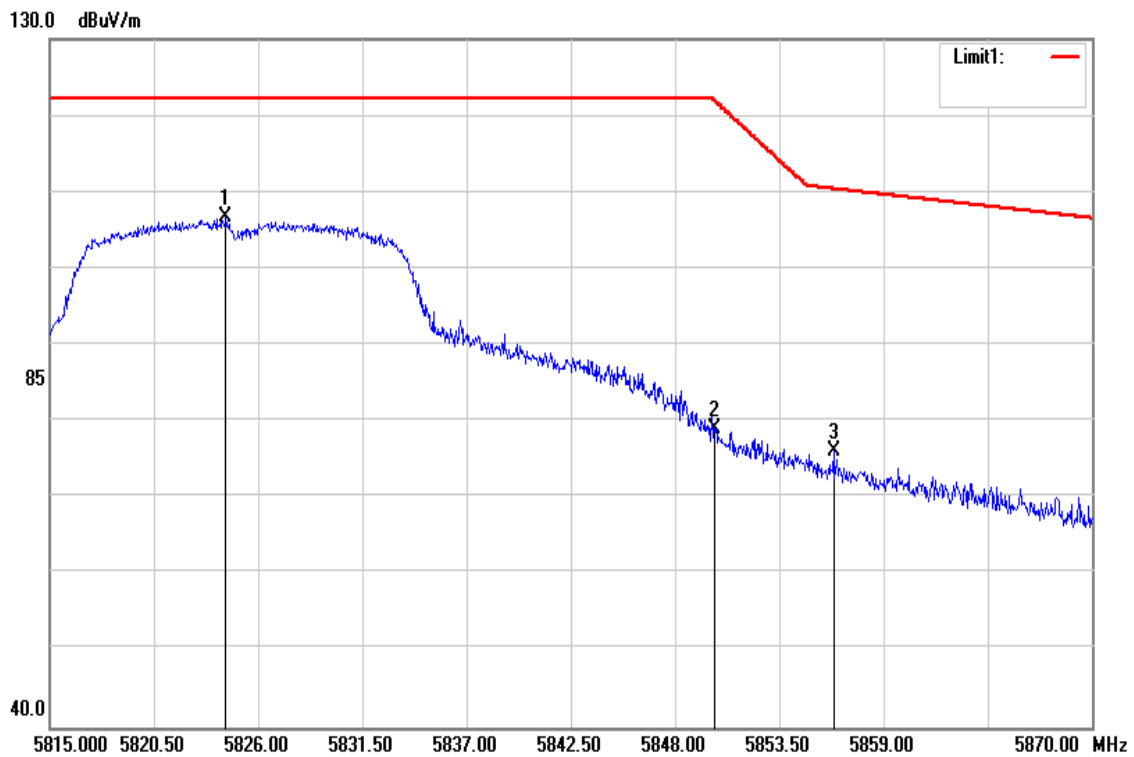

Frequency (MHz)	Reading (dBuV)	Correct Factor (dB/m)	Result (dBuV/m)	Limit (dBuV/m)	Margin (dB)	Remark
5824.295	99.95	6.78	106.73	-	-	peak
5850.090	72.22	6.85	79.07	121.99	-42.92	peak
5856.360	69.16	6.86	76.02	110.42	-34.40	peak

Test Mode	IEEE 802.11n HT20 / 5825 MHz	Temp/Hum	22(°C)/ 34%RH
Test Item	Band Edge	Test Date	July 17, 2018
Polarize	Vertical	Test Engineer	Jerry Chuang
Detector	Average		

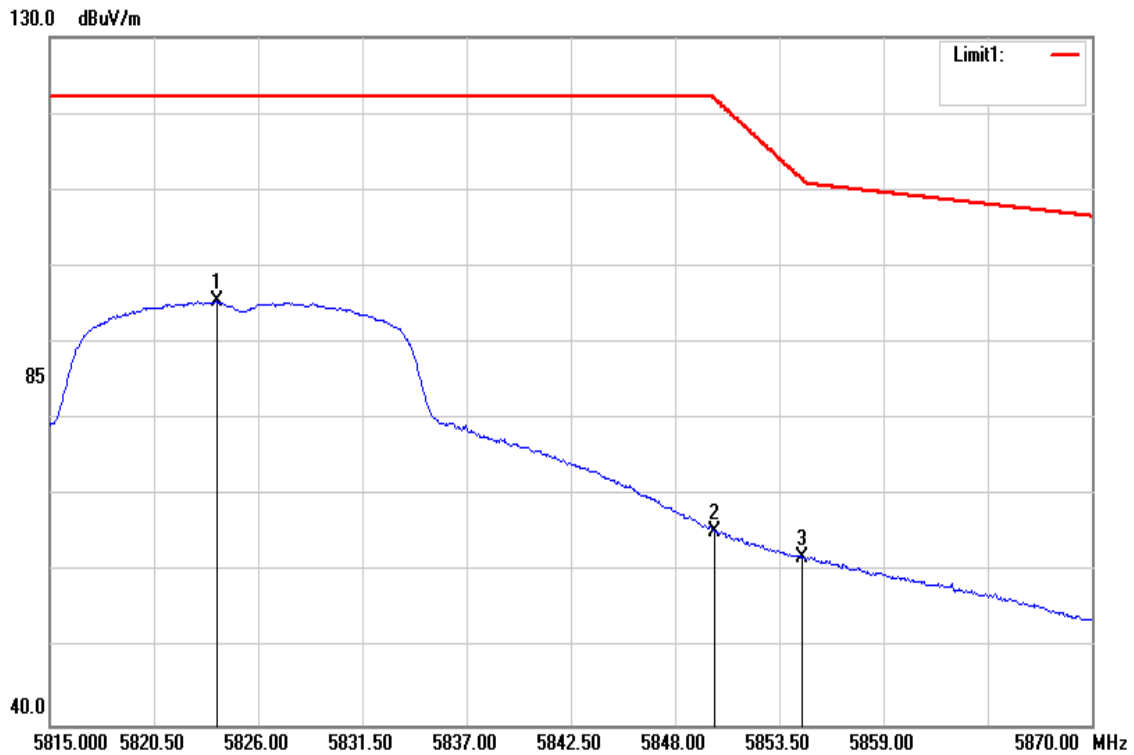

Frequency (MHz)	Reading (dBuV)	Correct Factor (dB/m)	Result (dBuV/m)	Limit (dBuV/m)	Margin (dB)	Remark
5823.800	88.65	6.78	95.43	-	-	AVG
5850.090	58.55	6.85	65.40	121.99	-56.59	AVG
5854.710	55.12	6.86	61.98	111.46	-49.48	AVG

Test Mode	IEEE 802.11n HT40/ 5755 MHz	Temp/Hum	22(°C)/ 34%RH
Test Item	Band Edge	Test Date	July 17, 2018
Polarize	Vertical	Test Engineer	Jerry Chuang
Detector	Peak		

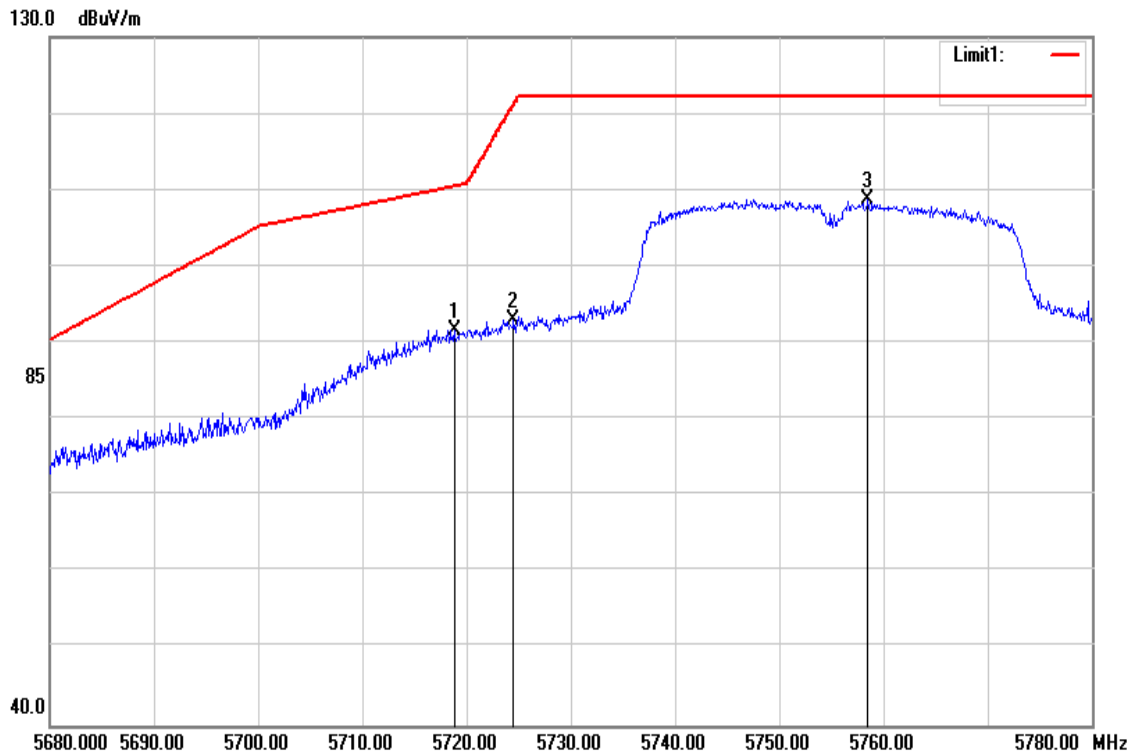

Frequency (MHz)	Reading (dBuV)	Correct Factor (dB/m)	Result (dBuV/m)	Limit (dBuV/m)	Margin (dB)	Remark
5718.800	85.19	6.50	91.69	110.46	-18.77	peak
5724.500	86.49	6.52	93.01	121.06	-28.05	peak
5758.500	102.14	6.61	108.75	-	-	peak

Test Mode	IEEE 802.11n HT40/ 5755 MHz	Temp/Hum	22(°C)/ 34%RH
Test Item	Band Edge	Test Date	July 17, 2018
Polarize	Vertical	Test Engineer	Jerry Chuang
Detector	Average		

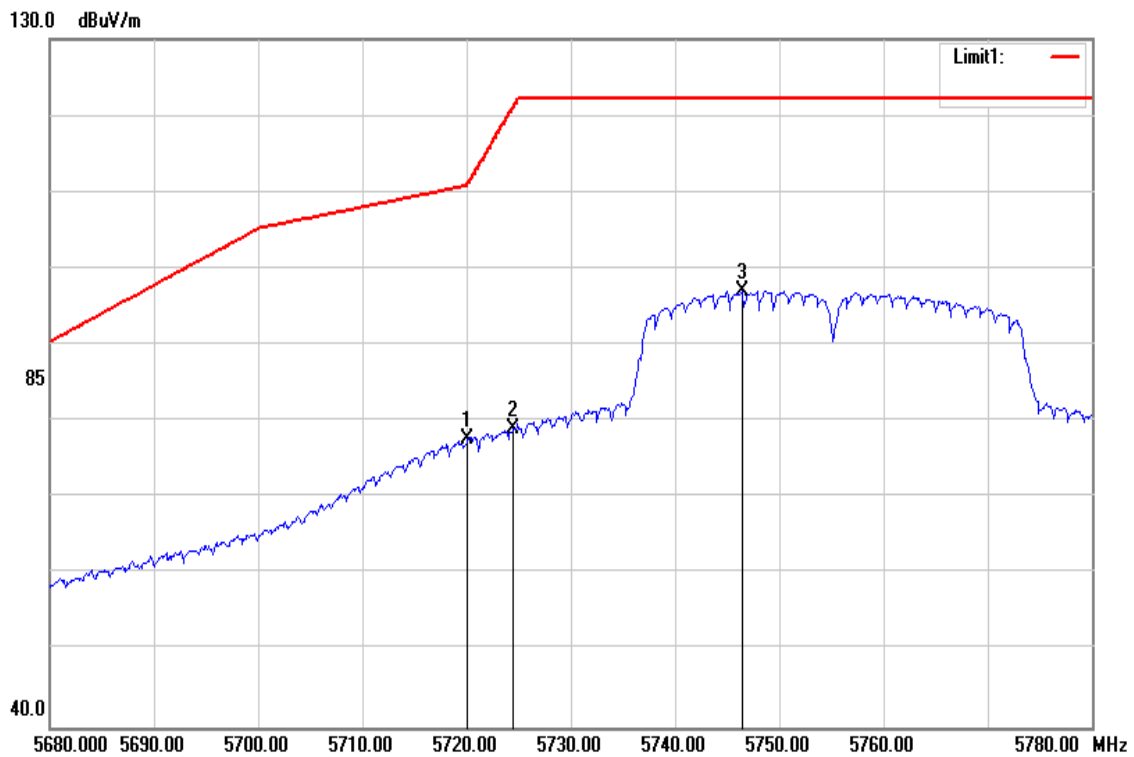

Frequency (MHz)	Reading (dBuV)	Correct Factor (dB/m)	Result (dBuV/m)	Limit (dBuV/m)	Margin (dB)	Remark
5720.100	71.09	6.50	77.59	111.03	-33.44	AVG
5724.500	72.61	6.52	79.13	121.06	-41.93	AVG
5746.400	90.45	6.58	97.03	-	-	AVG

Test Mode	IEEE 802.11n HT40/ 5795 MHz	Temp/Hum	22(°C)/ 34%RH
Test Item	Band Edge	Test Date	July 17, 2018
Polarize	Vertical	Test Engineer	Jerry Chuang
Detector	Peak		

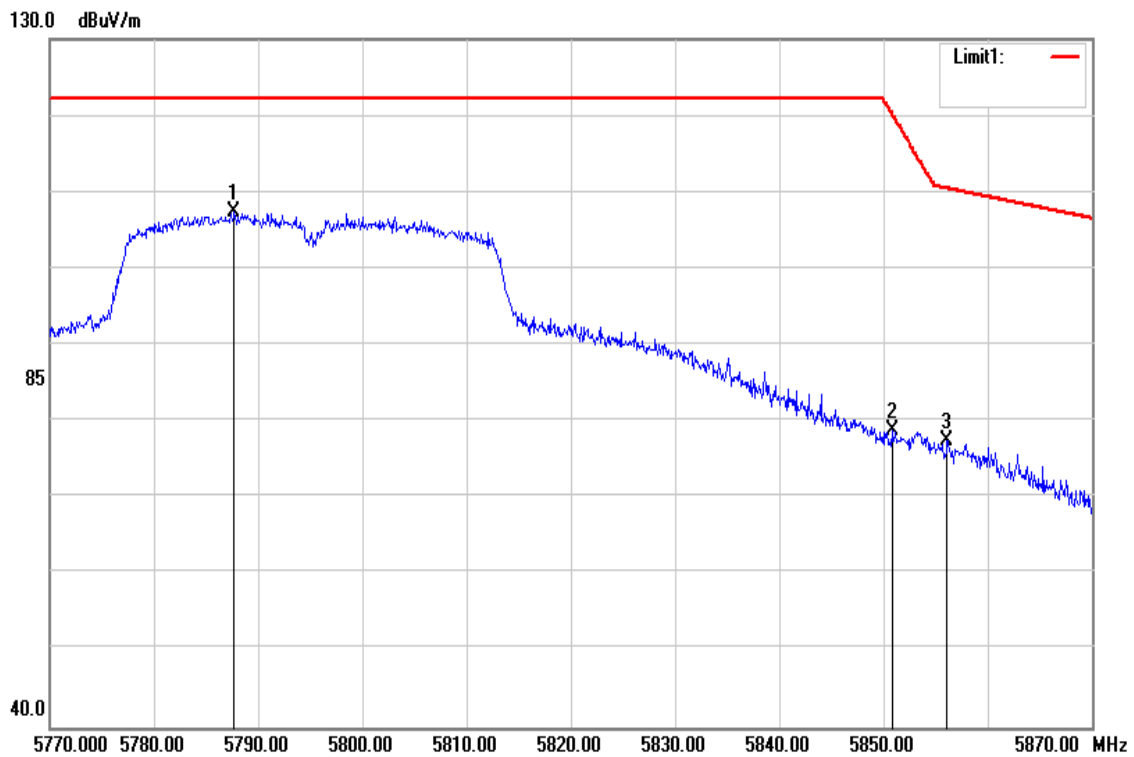

Frequency (MHz)	Reading (dBuV)	Correct Factor (dB/m)	Result (dBuV/m)	Limit (dBuV/m)	Margin (dB)	Remark
5787.700	100.60	6.69	107.29	-	-	peak
5850.800	72.01	6.85	78.86	120.38	-41.52	peak
5856.100	70.64	6.86	77.50	110.49	-32.99	peak

Test Mode	IEEE 802.11n HT40/ 5795 MHz	Temp/Hum	22(°C)/ 34%RH
Test Item	Band Edge	Test Date	July 17, 2018
Polarize	Vertical	Test Engineer	Jerry Chuang
Detector	Average		

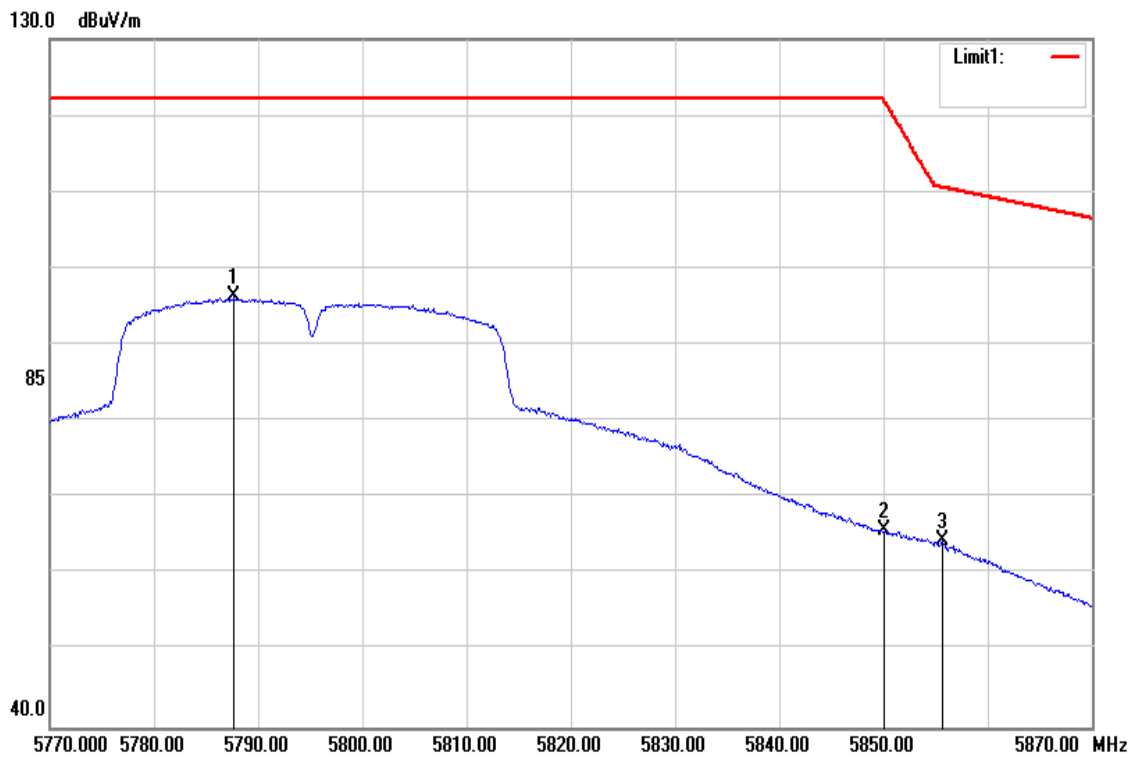

Frequency (MHz)	Reading (dBuV)	Correct Factor (dB/m)	Result (dBuV/m)	Limit (dBuV/m)	Margin (dB)	Remark
5787.700	89.57	6.69	96.26	-	-	AVG
5850.000	58.80	6.85	65.65	122.20	-56.55	AVG
5855.600	57.58	6.86	64.44	110.63	-46.19	AVG

Report No.: T180627D11-RP4

Test Mode	IEEE 802.11ac VHT80 / 5775 MHz	Temp/Hum	22(°C)/ 34%RH
Test Item	Band Edge	Test Date	July 17, 2018
Polarize	Vertical	Test Engineer	Jerry Chuang
Detector	Peak		

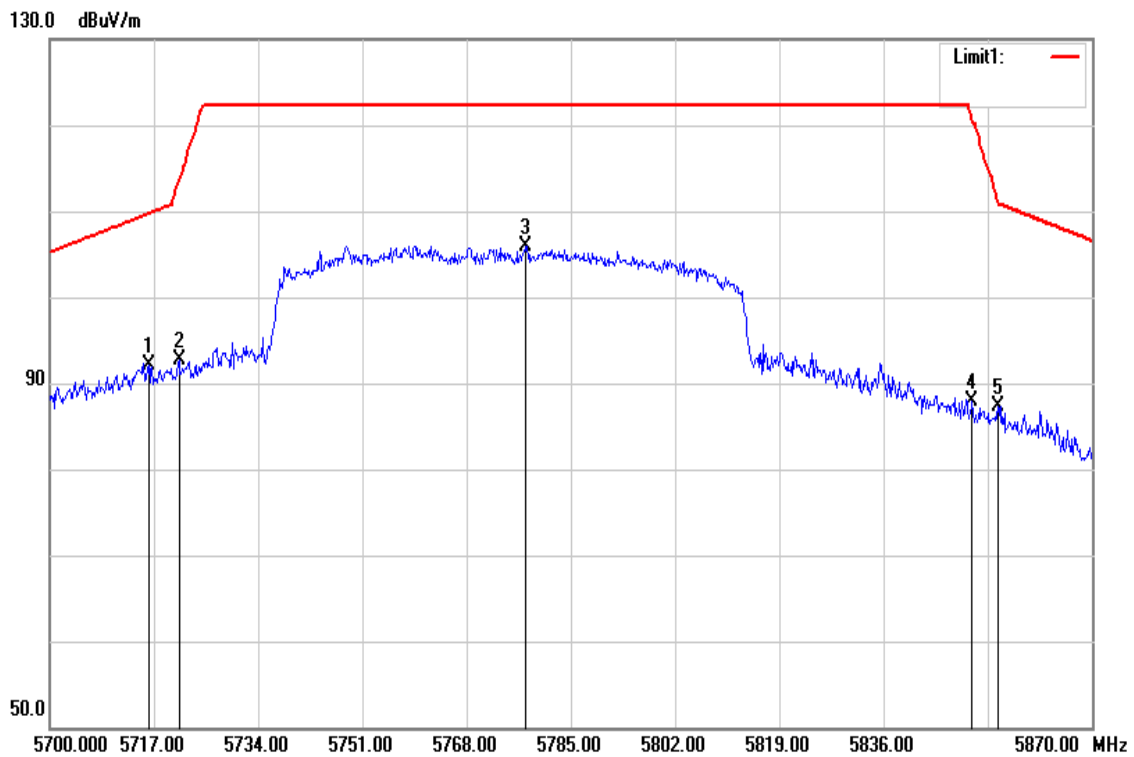

Frequency (MHz)	Reading (dBuV)	Correct Factor (dB/m)	Result (dBuV/m)	Limit (dBuV/m)	Margin (dB)	Remark
5716.150	85.52	6.49	92.01	109.72	-17.71	peak
5721.080	86.14	6.51	92.65	113.26	-20.61	peak
5777.690	99.34	6.66	106.00	-	-	peak
5850.450	81.07	6.85	87.92	121.17	-33.25	peak
5854.700	80.39	6.86	87.25	111.48	-24.23	peak

Test Mode	IEEE 802.11ac VHT80 / 5775 MHz	Temp/Hum	22(°C)/ 34%RH
Test Item	Band Edge	Test Date	July 17, 2018
Polarize	Vertical	Test Engineer	Jerry Chuang
Detector	Average		

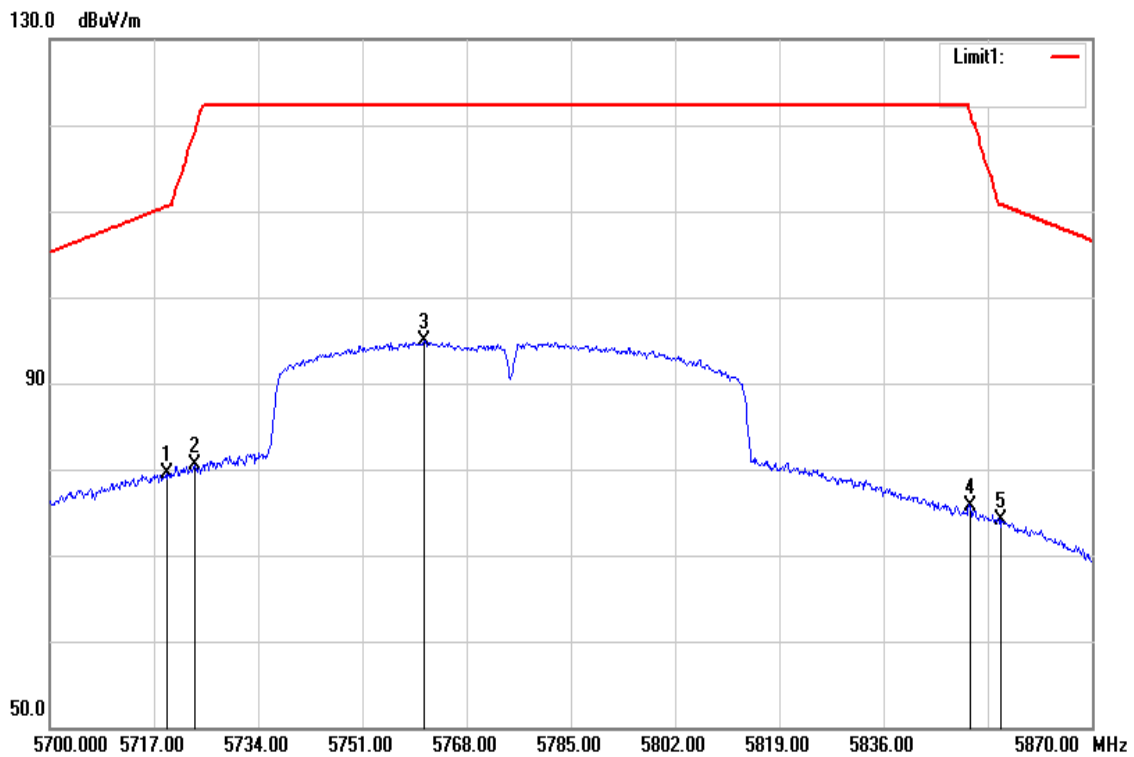

Frequency (MHz)	Reading (dBuV)	Correct Factor (dB/m)	Result (dBuV/m)	Limit (dBuV/m)	Margin (dB)	Remark
5719.210	72.95	6.50	79.45	110.58	-31.13	AVG
5723.630	73.91	6.52	80.43	119.08	-38.65	AVG
5761.030	88.24	6.61	94.85	-	-	AVG
5850.110	68.84	6.85	75.69	121.95	-46.26	AVG
5855.210	67.32	6.86	74.18	110.74	-36.56	AVG

Band Edge Test Data for UNII-1

For Dipole Antenna

Test Mode	IEEE 802.11a / 5180MHZ	Temp/Hum	22(°C)/ 34%RH
Test Item	Band Edge	Test Date	July 13, 2018
Polarize	Vertical	Test Engineer	Jerry Chuang
Detector	Peak		

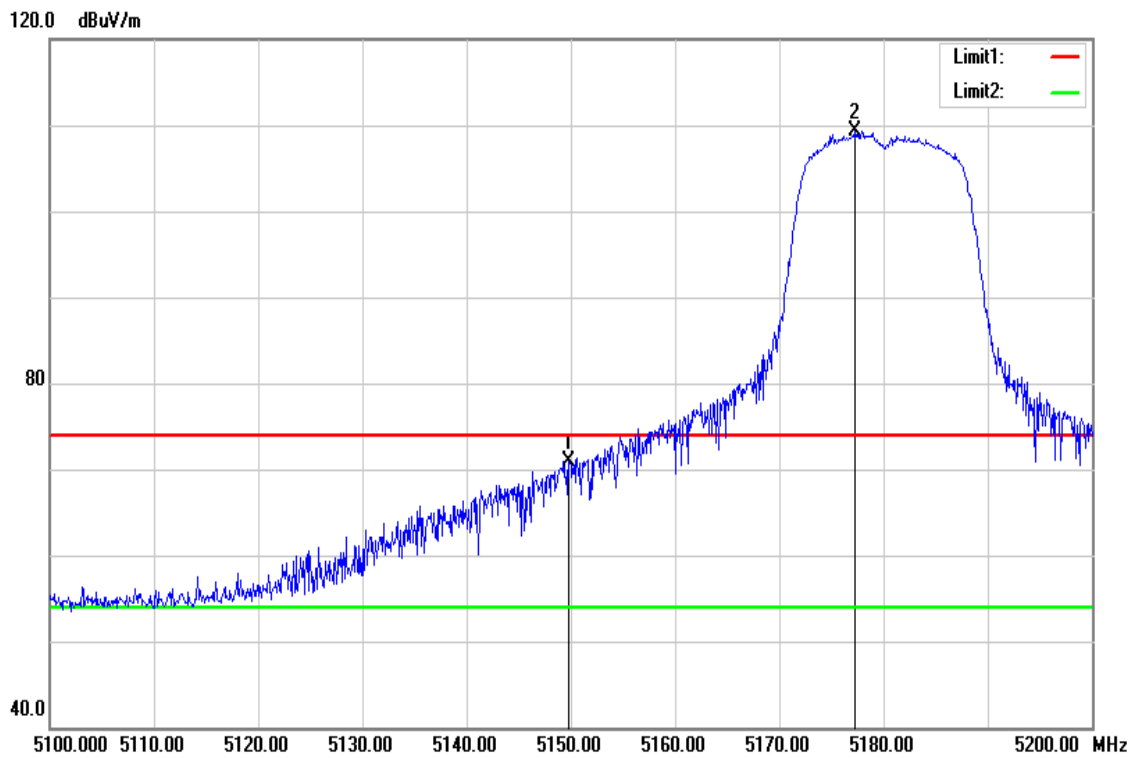

Frequency (MHz)	Reading (dBuV)	Correct Factor (dB/m)	Result (dBuV/m)	Limit (dBuV/m)	Margin (dB)	Remark
5149.800	65.87	5.06	70.93	74.00	-3.07	peak
5177.300	104.20	5.14	109.34	-	-	peak

Test Mode	IEEE 802.11a / 5180MHZ	Temperature	22(°C)/ 34%RH
Test Item	Band Edge	Test Date	July 13, 2018
Polarize	Vertical	Test Engineer	Jerry Chuang
Detector	Average		

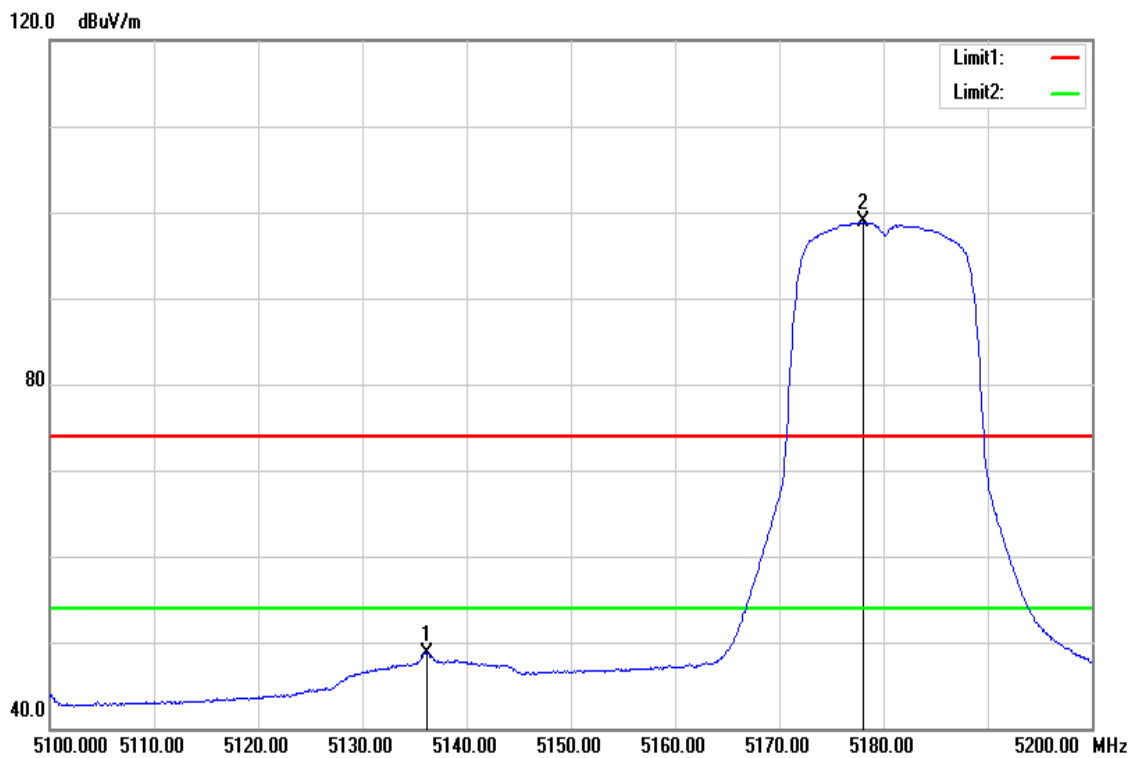

Frequency (MHz)	Reading (dBuV)	Correct Factor (dB/m)	Result (dBuV/m)	Limit (dBuV/m)	Margin (dB)	Remark
5136.200	43.77	5.03	48.80	54.00	-5.20	AVG
5178.100	93.69	5.14	98.83	-	-	AVG

Test Mode	IEEE 802.11a / 5240MHZ	Temp/Hum	22(°C)/ 34%RH
Test Item	Band Edge	Test Date	July 16, 2018
Polarize	Vertical	Test Engineer	Jerry Chuang
Detector	Peak		

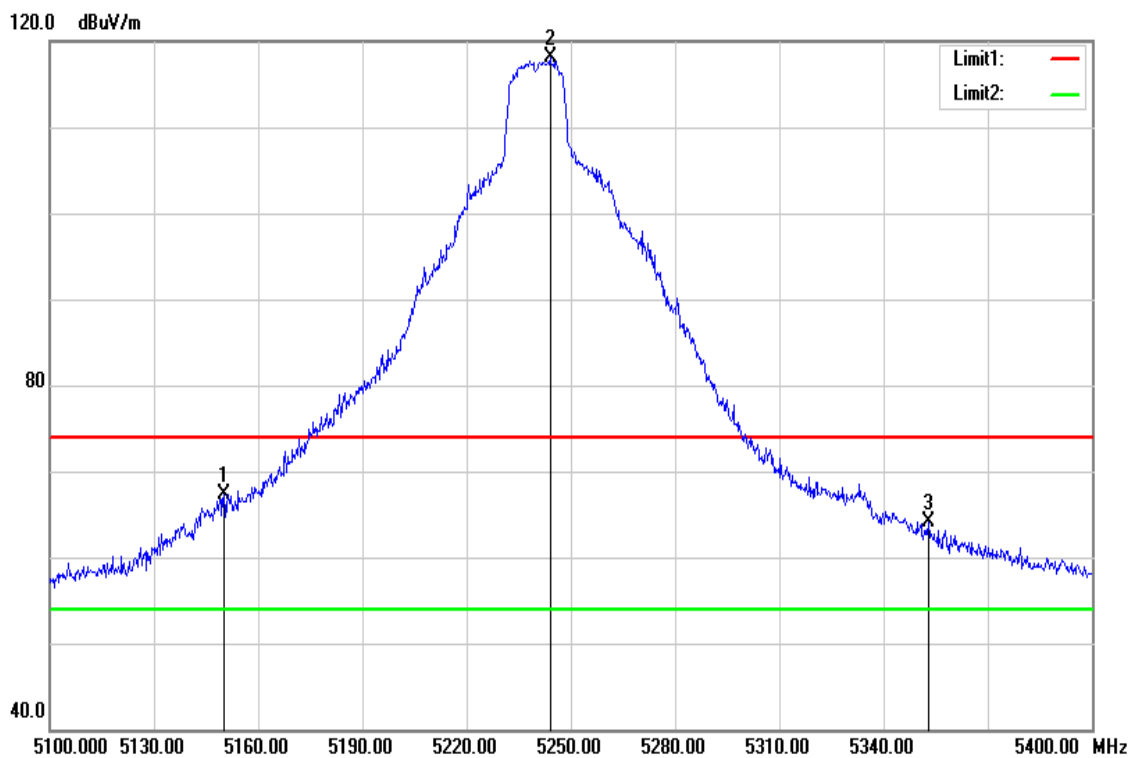

Frequency (MHz)	Reading (dBuV)	Correct Factor (dB/m)	Result (dBuV/m)	Limit (dBuV/m)	Margin (dB)	Remark
5150.000	62.30	5.06	67.36	74.00	-6.64	peak
5244.000	112.74	5.29	118.03	-	-	peak
5352.900	58.57	5.56	64.13	74.00	-9.87	peak

Test Mode	IEEE 802.11a / 5240MHZ	Temp/Hum	22(°C)/ 34%RH
Test Item	Band Edge	Test Date	July 13, 2018
Polarize	Vertical	Test Engineer	Jerry Chuang
Detector	Average		

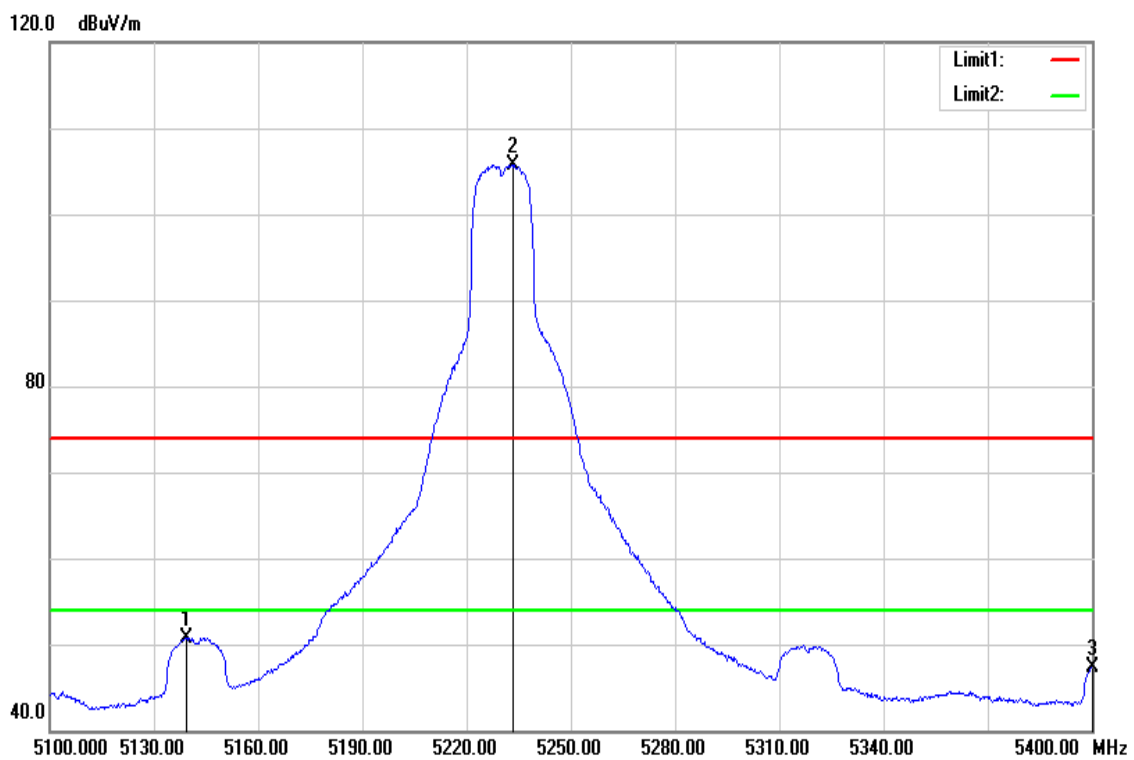

Frequency (MHz)	Reading (dBuV)	Correct Factor (dB/m)	Result (dBuV/m)	Limit (dBuV/m)	Margin (dB)	Remark
5139.300	45.70	5.03	50.73	54.00	-3.27	AVG
5233.200	100.42	5.27	105.69	-	-	AVG
5400.000	41.72	5.68	47.40	54.00	-6.60	AVG

Test Mode	IEEE 802.11n HT20 / 5180MHZ	Temp/Hum	22(°C)/ 34%RH
Test Item	Band Edge	Test Date	July 16, 2018
Polarize	Vertical	Test Engineer	Jerry Chuang
Detector	Peak		

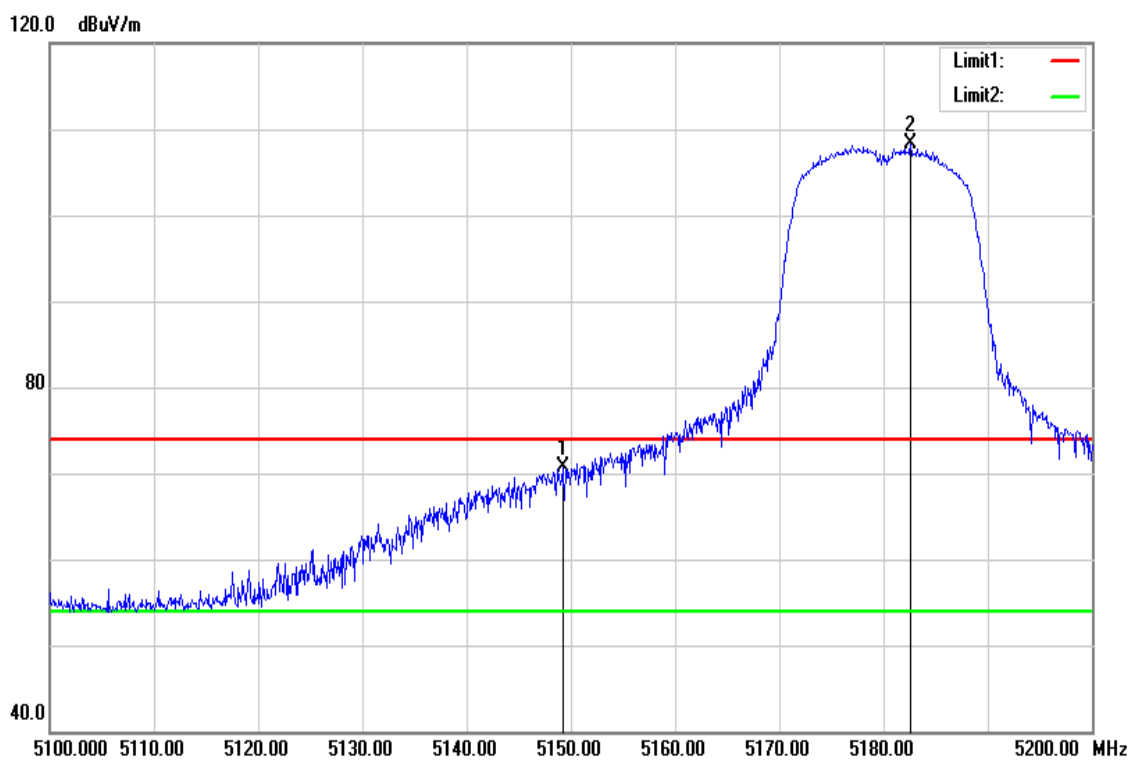

Frequency (MHz)	Reading (dBuV)	Correct Factor (dB/m)	Result (dBuV/m)	Limit (dBuV/m)	Margin (dB)	Remark
5149.200	65.71	5.06	70.77	74.00	-3.23	peak
5182.600	103.18	5.14	108.32	-	-	peak

Test Mode	IEEE 802.11n HT20 / 5180MHZ	Temp/Hum	22(°C)/ 34%RH
Test Item	Band Edge	Test Date	July 16, 2018
Polarize	Vertical	Test Engineer	Jerry Chuang
Detector	Average		

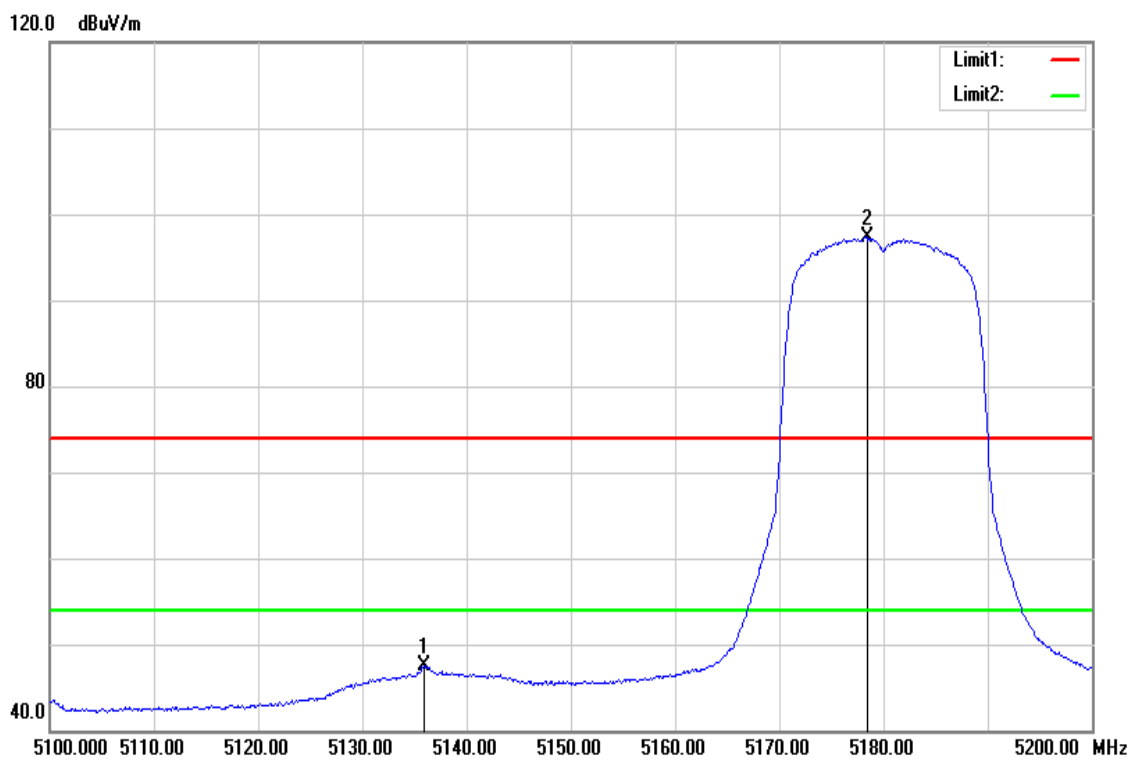

Frequency (MHz)	Reading (dBuV)	Correct Factor (dB/m)	Result (dBuV/m)	Limit (dBuV/m)	Margin (dB)	Remark
5135.900	42.52	5.03	47.55	54.00	-6.45	AVG
5178.400	92.18	5.14	97.32	-	-	AVG

Report No.: T180627D11-RP4

Test Mode	IEEE 802.11n HT20 / 5240MHZ	Temp/Hum	22(°C)/ 34%RH
Test Item	Band Edge	Test Date	July 16, 2018
Polarize	Vertical	Test Engineer	Jerry Chuang
Detector	Peak		

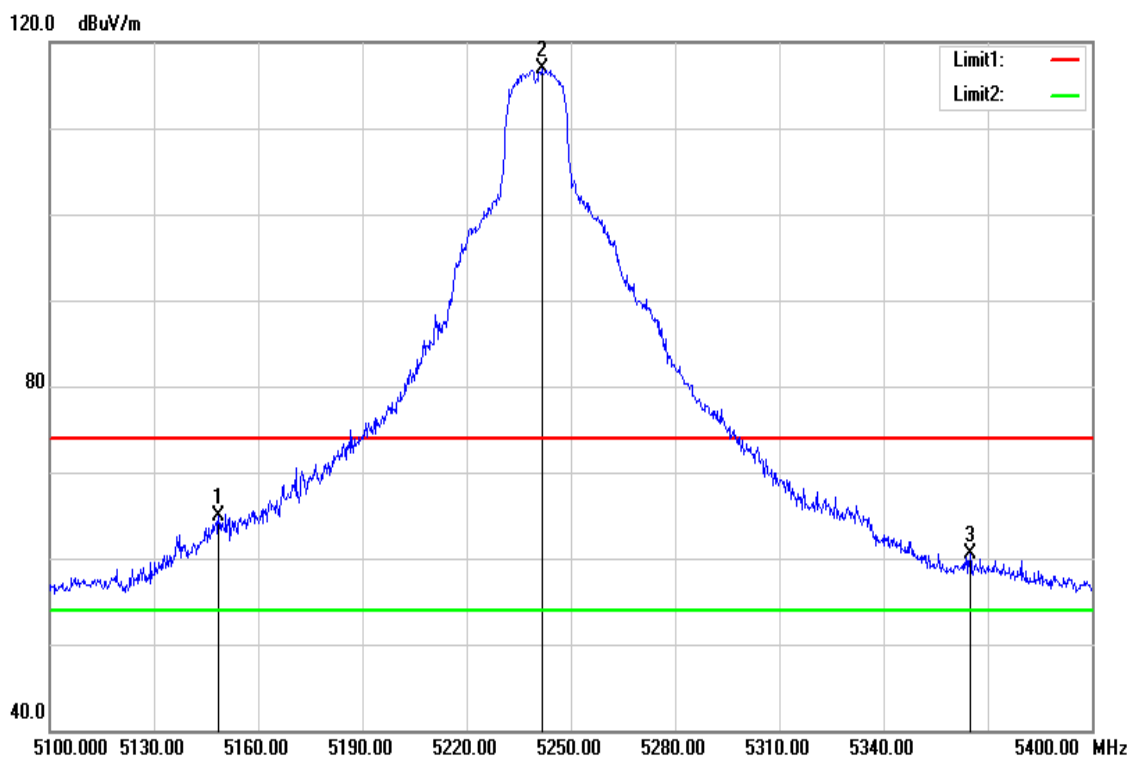

Frequency (MHz)	Reading (dBuV)	Correct Factor (dB/m)	Result (dBuV/m)	Limit (dBuV/m)	Margin (dB)	Remark
5148.600	59.92	5.06	64.98	74.00	-9.02	peak
5241.600	111.57	5.28	116.85	-	-	peak
5364.900	55.00	5.59	60.59	74.00	-13.41	peak

Test Mode	IEEE 802.11n HT20 / 5240MHZ	Temperature	22(°C)/ 34%RH
Test Item	Band Edge	Test Date	July 16, 2018
Polarize	Vertical	Test Engineer	Jerry Chuang
Detector	Average		

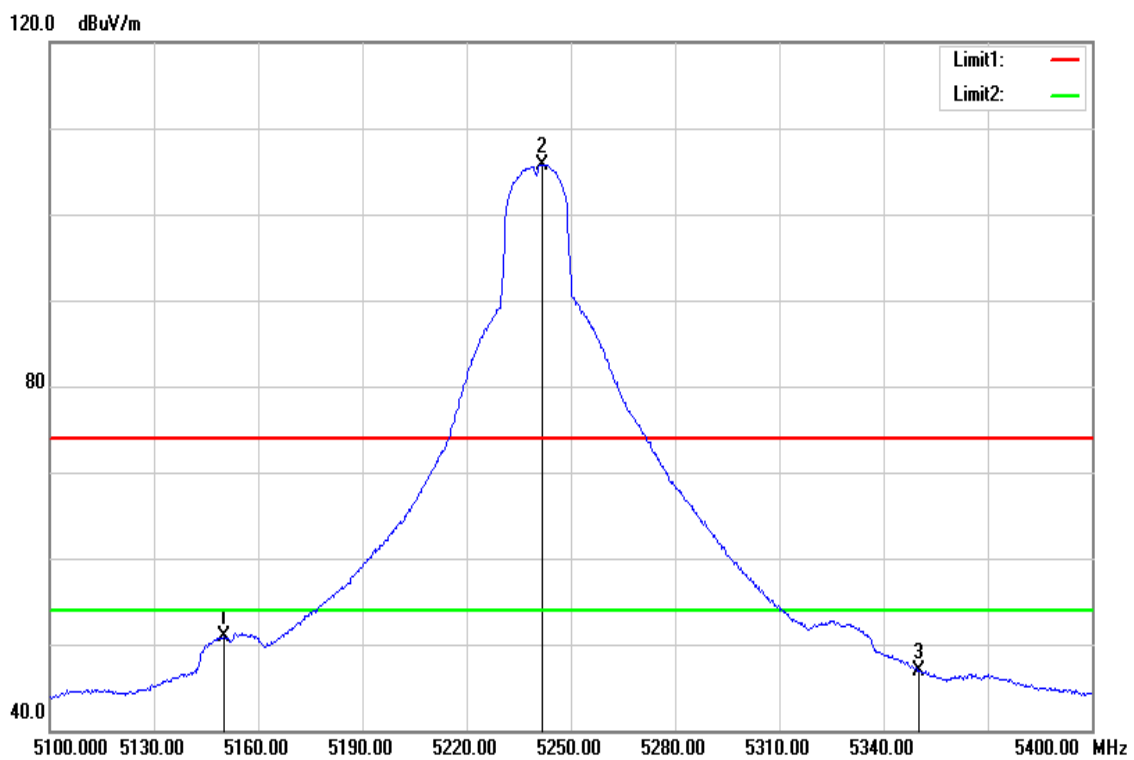

Frequency (MHz)	Reading (dBuV)	Correct Factor (dB/m)	Result (dBuV/m)	Limit (dBuV/m)	Margin (dB)	Remark
5150.000	45.89	5.06	50.95	54.00	-3.05	AVG
5241.900	100.51	5.29	105.80	-	-	AVG
5350.200	41.39	5.56	46.95	54.00	-7.05	AVG

Test Mode	IEEE 802.11n HT40 / 5190MHz	Temp/Hum	22(°C)/ 34%RH
Test Item	Band Edge	Test Date	July 16, 2018
Polarize	Vertical	Test Engineer	Jerry Chuang
Detector	Peak		

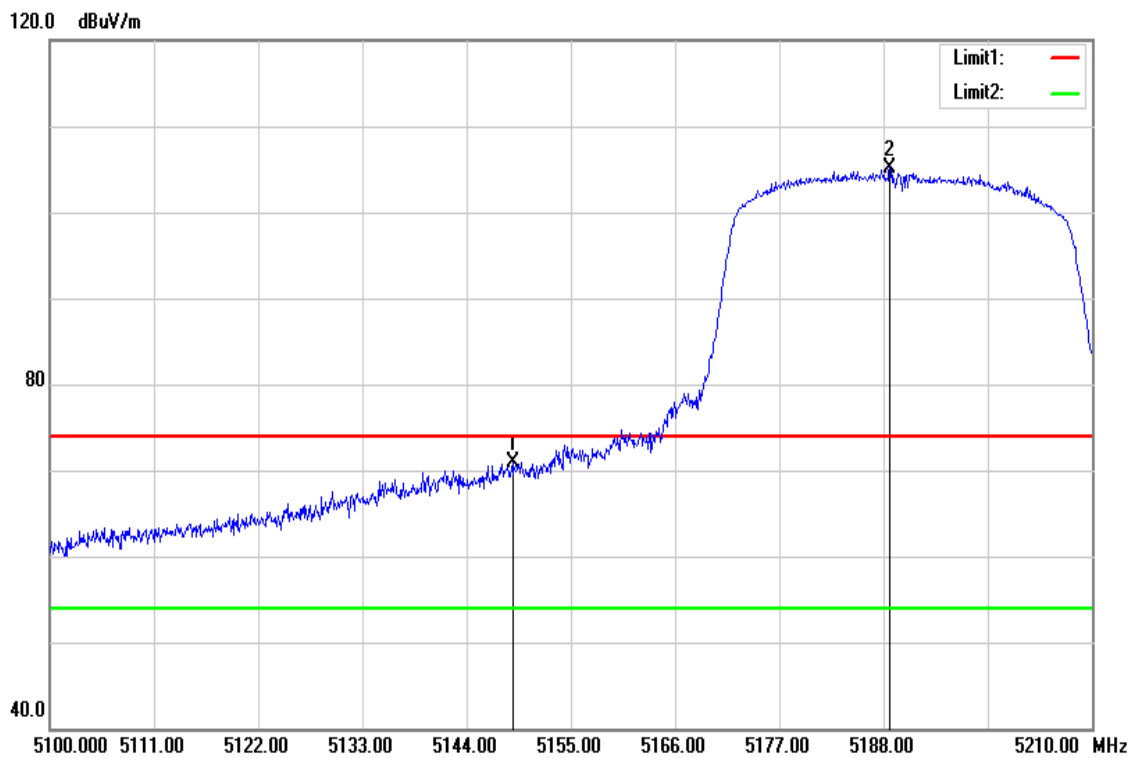

Frequency (MHz)	Reading (dBuV)	Correct Factor (dB/m)	Result (dBuV/m)	Limit (dBuV/m)	Margin (dB)	Remark
5148.840	65.82	5.06	70.88	74.00	-3.12	peak
5188.660	100.04	5.16	105.20	-	-	peak

Test Mode	IEEE 802.11n HT40 / 5190MHZ	Temperature	22(°C)/ 34%RH
Test Item	Band Edge	Test Date	July 16, 2018
Polarize	Vertical	Test Engineer	Jerry Chuang
Detector	Average		

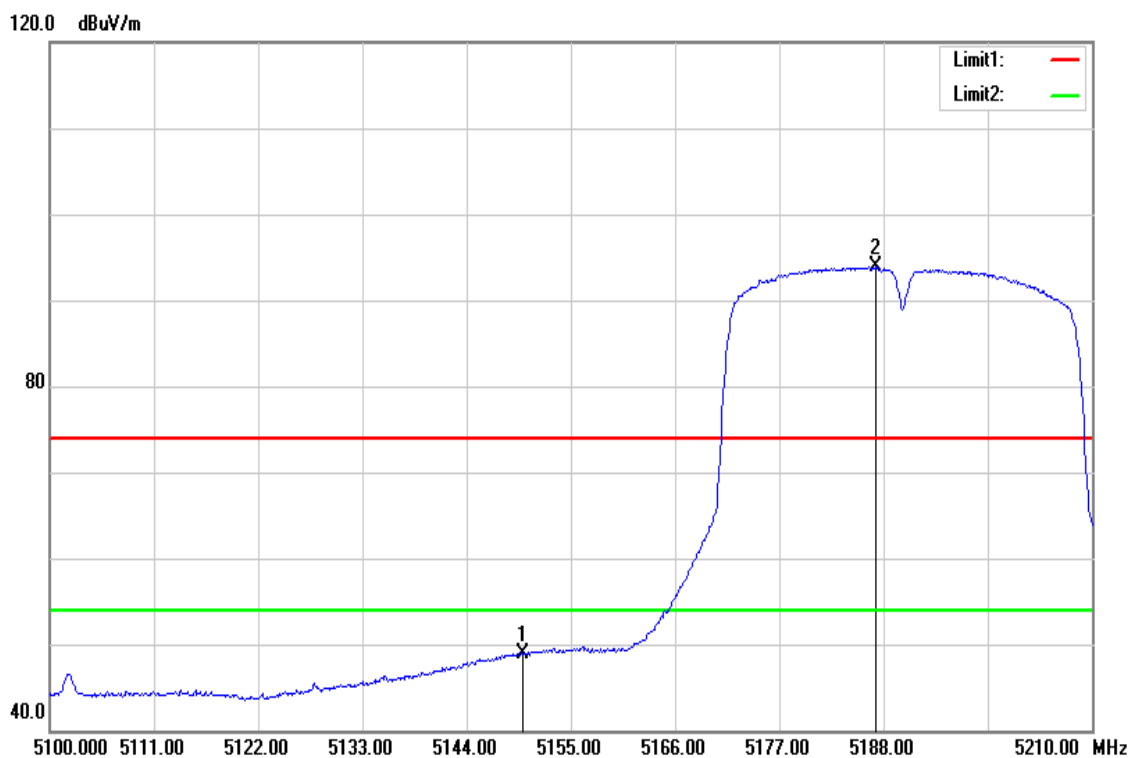

Frequency (MHz)	Reading (dBuV)	Correct Factor (dB/m)	Result (dBuV/m)	Limit (dBuV/m)	Margin (dB)	Remark
5150.000	43.87	5.06	48.93	54.00	-5.07	AVG
5187.230	88.71	5.15	93.86	-	-	AVG

Report No.: T180627D11-RP4

Test Mode	IEEE 802.11n HT40 / 5230MHZ	Temp/Hum	22(°C)/ 34%RH
Test Item	Band Edge	Test Date	July 16, 2018
Polarize	Vertical	Test Engineer	Jerry Chuang
Detector	Peak		

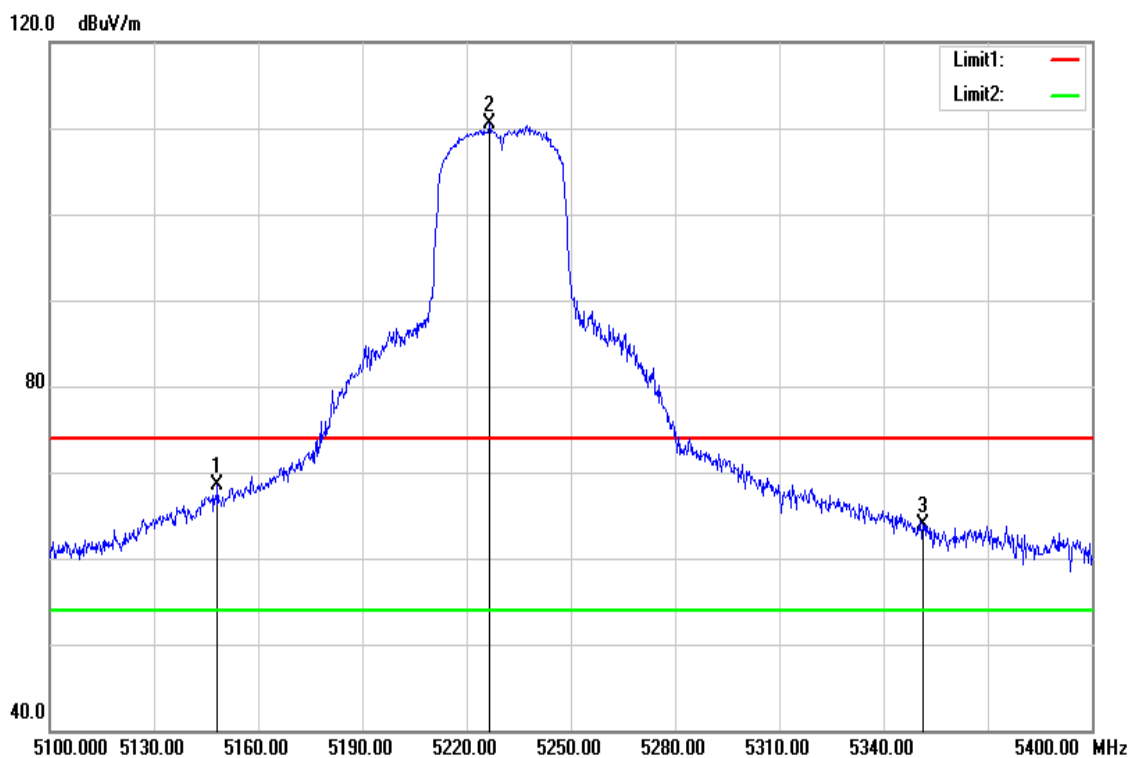

Frequency (MHz)	Reading (dBuV)	Correct Factor (dB/m)	Result (dBuV/m)	Limit (dBuV/m)	Margin (dB)	Remark
5148.300	63.47	5.06	68.53	74.00	-5.47	peak
5226.600	105.15	5.26	110.41	-	-	peak
5351.400	58.43	5.56	63.99	74.00	-10.01	peak

Report No.: T180627D11-RP4

Test Mode	IEEE 802.11n HT40 / 5230MHZ	Temp/Hum	22(°C)/ 34%RH
Test Item	Band Edge	Test Date	July 16, 2018
Polarize	Vertical	Test Engineer	Jerry Chuang
Detector	Average		

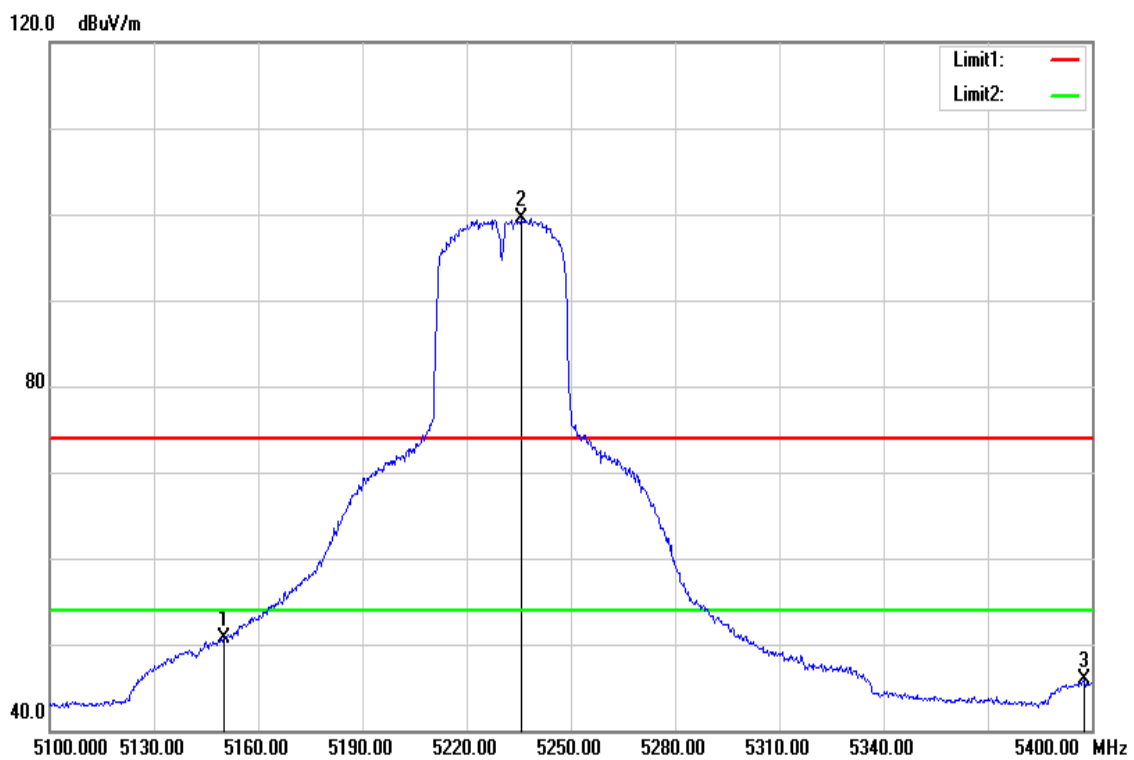

Frequency (MHz)	Reading (dBuV)	Correct Factor (dB/m)	Result (dBuV/m)	Limit (dBuV/m)	Margin (dB)	Remark
5150.000	45.61	5.06	50.67	54.00	-3.33	AVG
5235.900	94.17	5.28	99.45	-	-	AVG
5397.600	40.24	5.68	45.92	54.00	-8.08	AVG

Test Mode	I EEE 802.11ac VHT80 / 5210MHZ	Temp/Hum	22(°C)/ 34%RH
Test Item	Band Edge	Test Date	July 16, 2018
Polarize	Vertical	Test Engineer	Jerry Chuang
Detector	Peak		

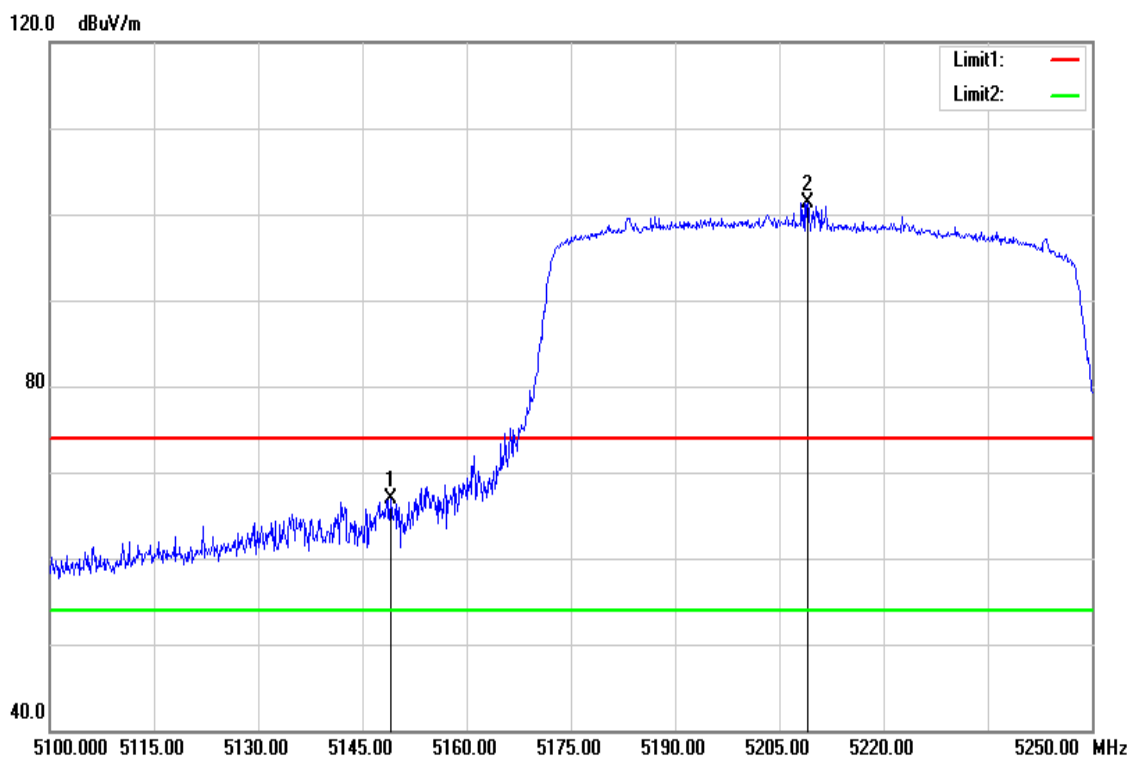

Frequency (MHz)	Reading (dBuV)	Correct Factor (dB/m)	Result (dBuV/m)	Limit (dBuV/m)	Margin (dB)	Remark
5149.050	61.75	5.06	66.81	74.00	-7.19	peak
5209.050	96.04	5.21	101.25	-	-	peak

Test Mode	I EEE 802.11ac VHT80 / 5210MHZ	Temp/Hum	22(°C)/ 34%RH
Test Item	Band Edge	Test Date	July 16, 2018
Polarize	Vertical	Test Engineer	Jerry Chuang
Detector	Average		

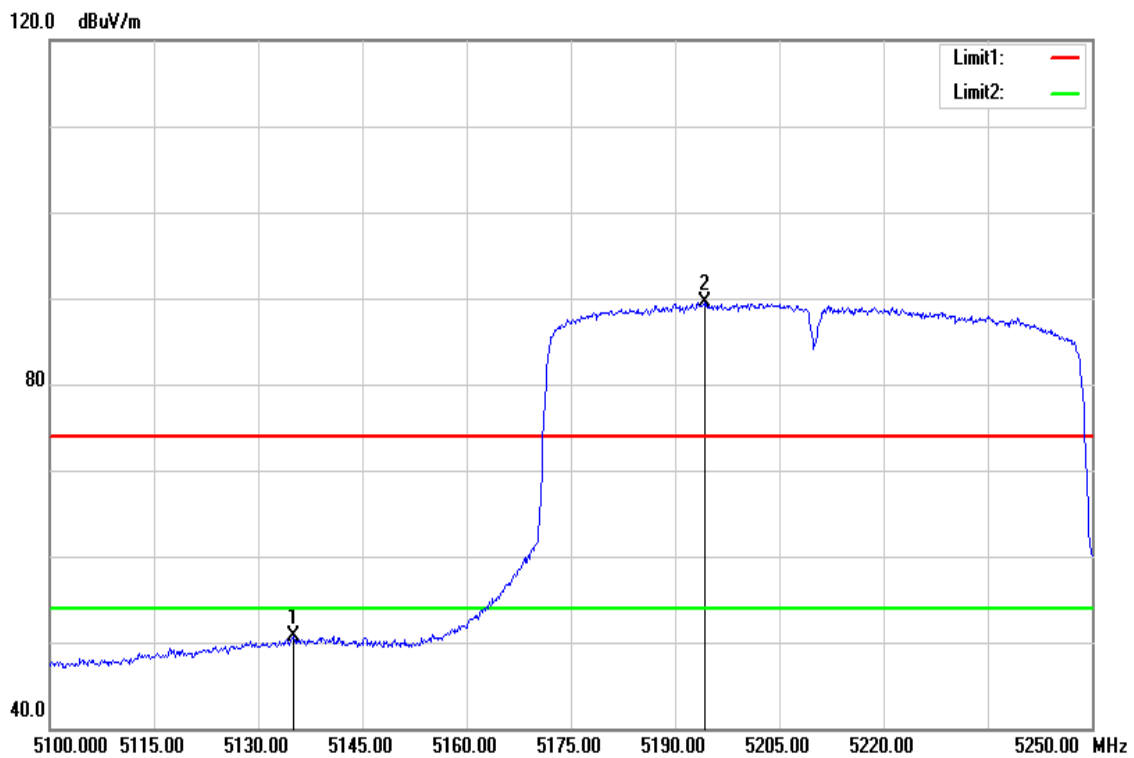

Frequency (MHz)	Reading (dBuV)	Correct Factor (dB/m)	Result (dBuV/m)	Limit (dBuV/m)	Margin (dB)	Remark
5135.100	45.67	5.03	50.70	54.00	-3.30	AVG
5194.200	84.28	5.17	89.45	-	-	AVG

Report No.: T180627D11-RP4

Band Edge Test Data for UNII-3

Test Mode	IEEE 802.11a / 5745 MHz	Temp/Hum	22(°C)/ 34%RH
Test Item	Band Edge	Test Date	July 16, 2018
Polarize	Vertical	Test Engineer	Jerry Chuang
Detector	Peak		

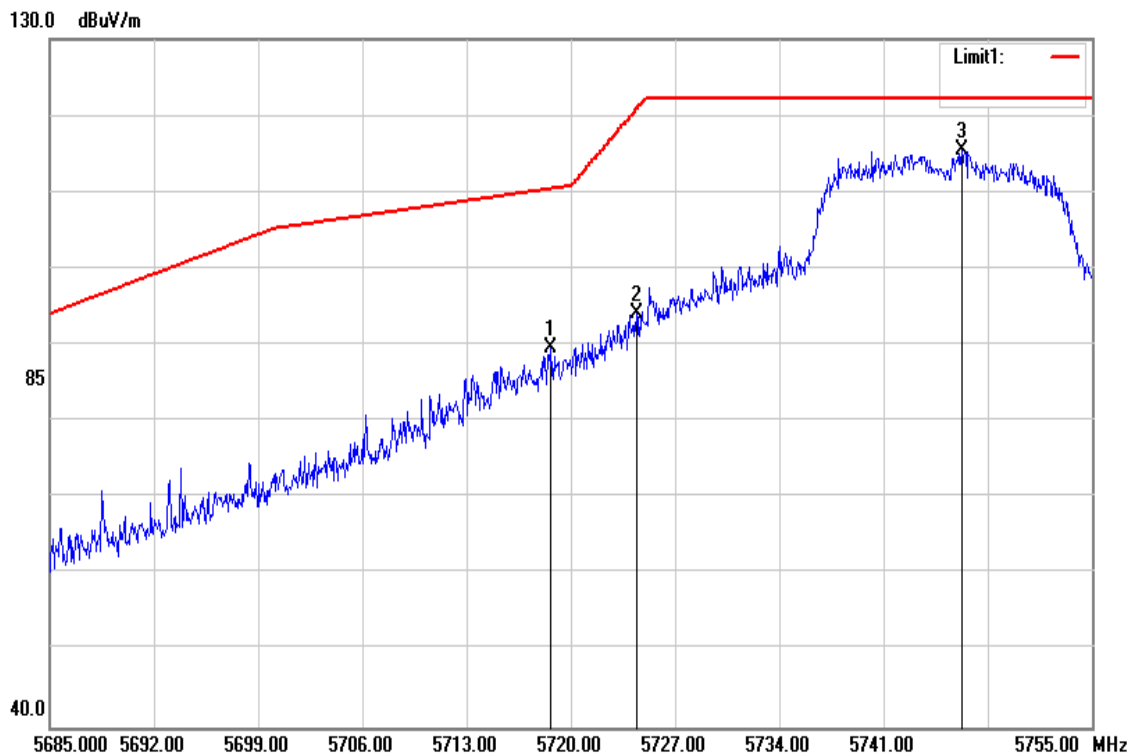

Frequency (MHz)	Reading (dBuV)	Correct Factor (dB/m)	Result (dBuV/m)	Limit (dBuV/m)	Margin (dB)	Remark
5718.670	83.10	6.50	89.60	110.43	-20.83	peak
5724.410	87.69	6.52	94.21	120.85	-26.64	peak
5746.250	108.94	6.58	115.52	-	-	peak

Test Mode	IEEE 802.11a / 5745 MHz	Temp/Hum	22(°C)/ 34%RH
Test Item	Band Edge	Test Date	July 16, 2018
Polarize	Vertical	Test Engineer	Jerry Chuang
Detector	Average		

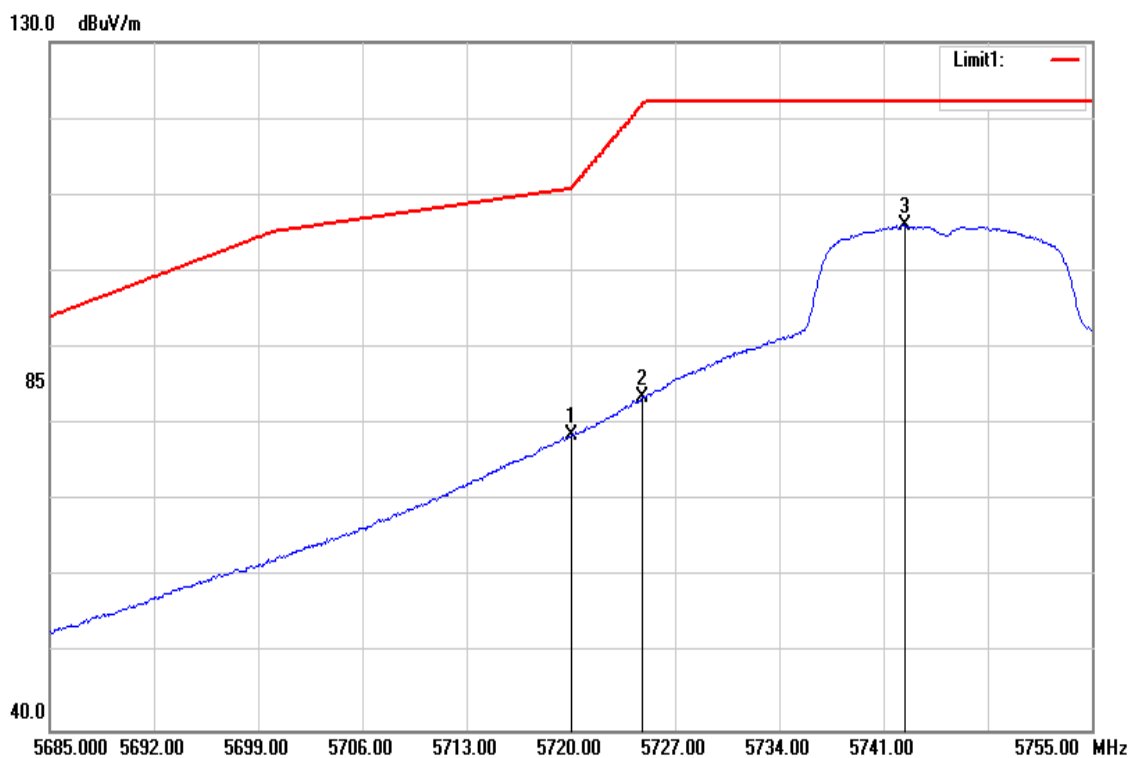

Frequency (MHz)	Reading (dBuV)	Correct Factor (dB/m)	Result (dBuV/m)	Limit (dBuV/m)	Margin (dB)	Remark
5720.000	72.14	6.50	78.64	110.80	-32.16	AVG
5724.830	77.07	6.52	83.59	121.81	-38.22	AVG
5742.400	99.40	6.56	105.96	-	-	AVG

Test Mode	IEEE 802.11a / 5825 MHz	Temp/Hum	22(°C)/ 34%RH
Test Item	Band Edge	Test Date	July 16, 2018
Polarize	Vertical	Test Engineer	Jerry Chuang
Detector	Peak		

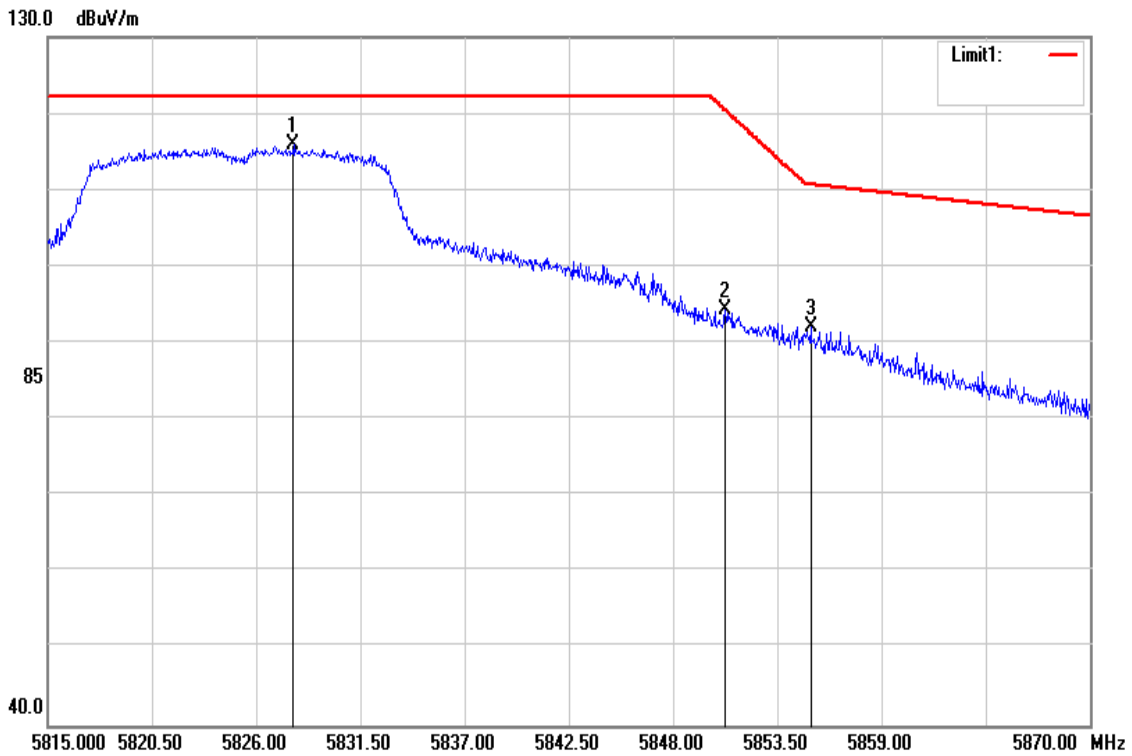

Frequency (MHz)	Reading (dBuV)	Correct Factor (dB/m)	Result (dBuV/m)	Limit (dBuV/m)	Margin (dB)	Remark
5827.980	109.05	6.79	115.84	-	-	peak
5850.750	87.39	6.85	94.24	120.49	-26.25	peak
5855.260	85.12	6.86	91.98	110.73	-18.75	peak

Test Mode	IEEE 802.11a / 5825 MHz	Temp/Hum	22(°C)/ 34%RH
Test Item	Band Edge	Test Date	July 16, 2018
Polarize	Vertical	Test Engineer	Jerry Chuang
Detector	Average		

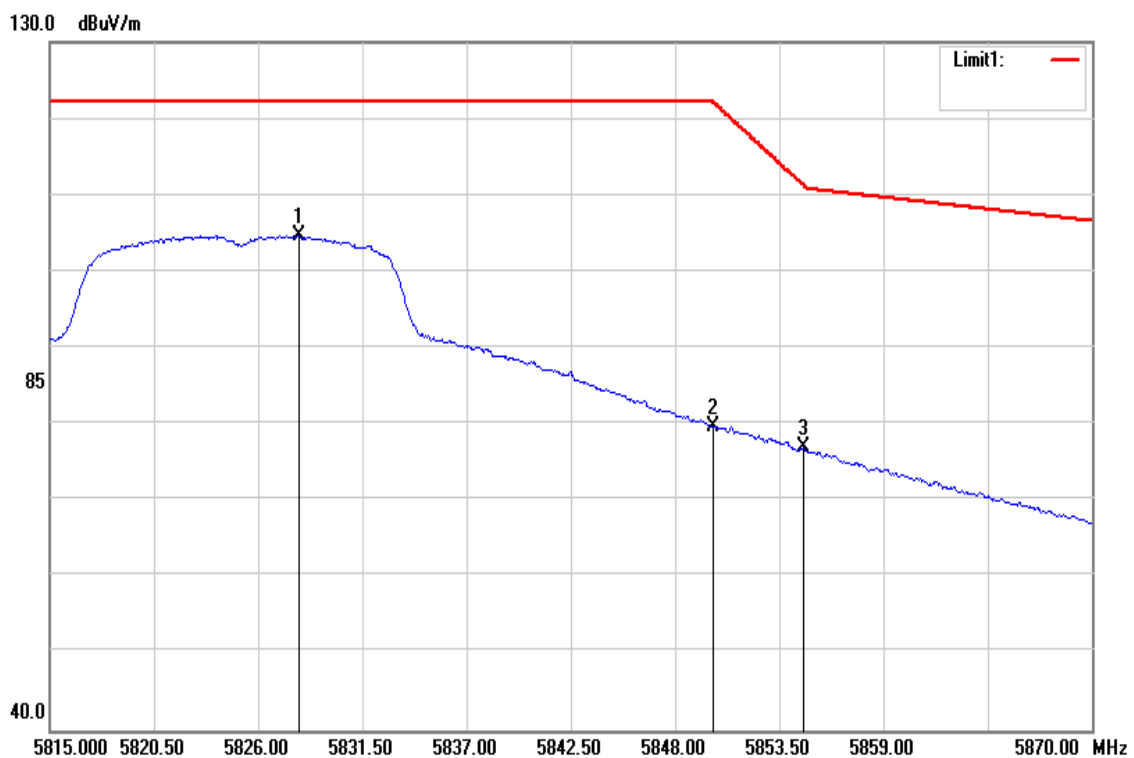

Frequency (MHz)	Reading (dBuV)	Correct Factor (dB/m)	Result (dBuV/m)	Limit (dBuV/m)	Margin (dB)	Remark
5828.145	97.90	6.79	104.69	-	-	AVG
5850.035	72.86	6.85	79.71	122.12	-42.41	AVG
5854.765	70.09	6.86	76.95	111.34	-34.39	AVG

Test Mode	IEEE 802.11n HT20 / 5745 MHz	Temp/Hum	22(°C)/ 34%RH
Test Item	Band Edge	Test Date	July 16, 2018
Polarize	Vertical	Test Engineer	Jerry Chuang
Detector	Peak		

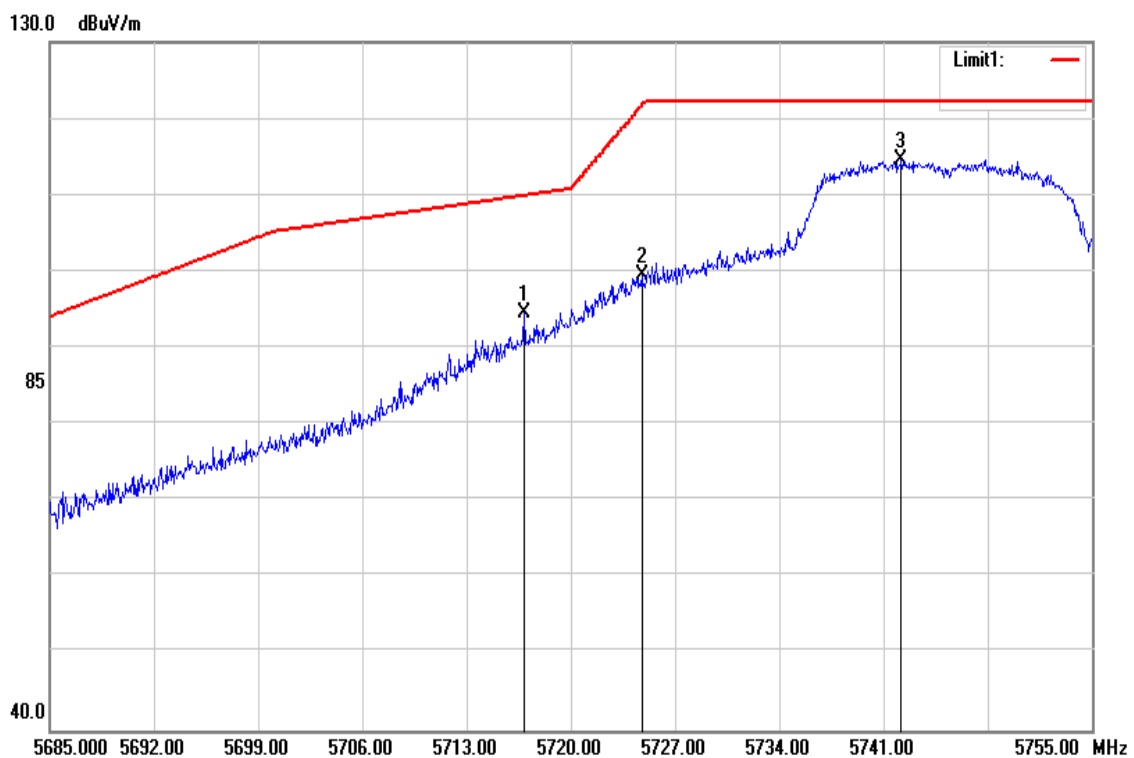

Frequency (MHz)	Reading (dBuV)	Correct Factor (dB/m)	Result (dBuV/m)	Limit (dBuV/m)	Margin (dB)	Remark
5716.850	88.07	6.49	94.56	109.92	-15.36	peak
5724.760	93.04	6.52	99.56	121.65	-22.09	peak
5742.190	108.04	6.56	114.60	-	-	peak

Test Mode	IEEE 802.11n HT20 / 5745 MHz	Temp/Hum	22(°C)/ 34%RH
Test Item	Band Edge	Test Date	July 16, 2018
Polarize	Vertical	Test Engineer	Jerry Chuang
Detector	Average		

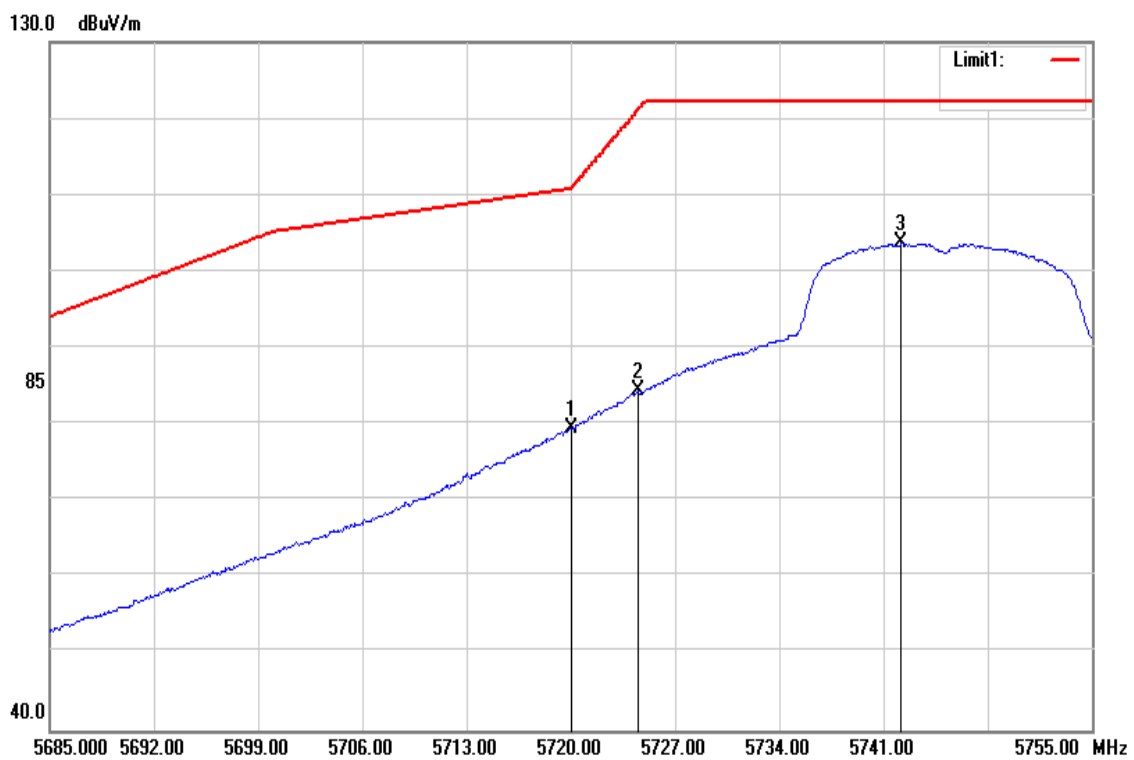

Frequency (MHz)	Reading (dBuV)	Correct Factor (dB/m)	Result (dBuV/m)	Limit (dBuV/m)	Margin (dB)	Remark
5720.000	73.01	6.50	79.51	110.80	-31.29	AVG
5724.480	77.82	6.52	84.34	121.01	-36.67	AVG
5742.190	97.14	6.56	103.70	-	-	AVG

Report No.: T180627D11-RP4

Test Mode	IEEE 802.11n HT20 / 5825 MHz	Temp/Hum	22(°C)/ 34%RH
Test Item	Band Edge	Test Date	July 16, 2018
Polarize	Vertical	Test Engineer	Jerry Chuang
Detector	Peak		

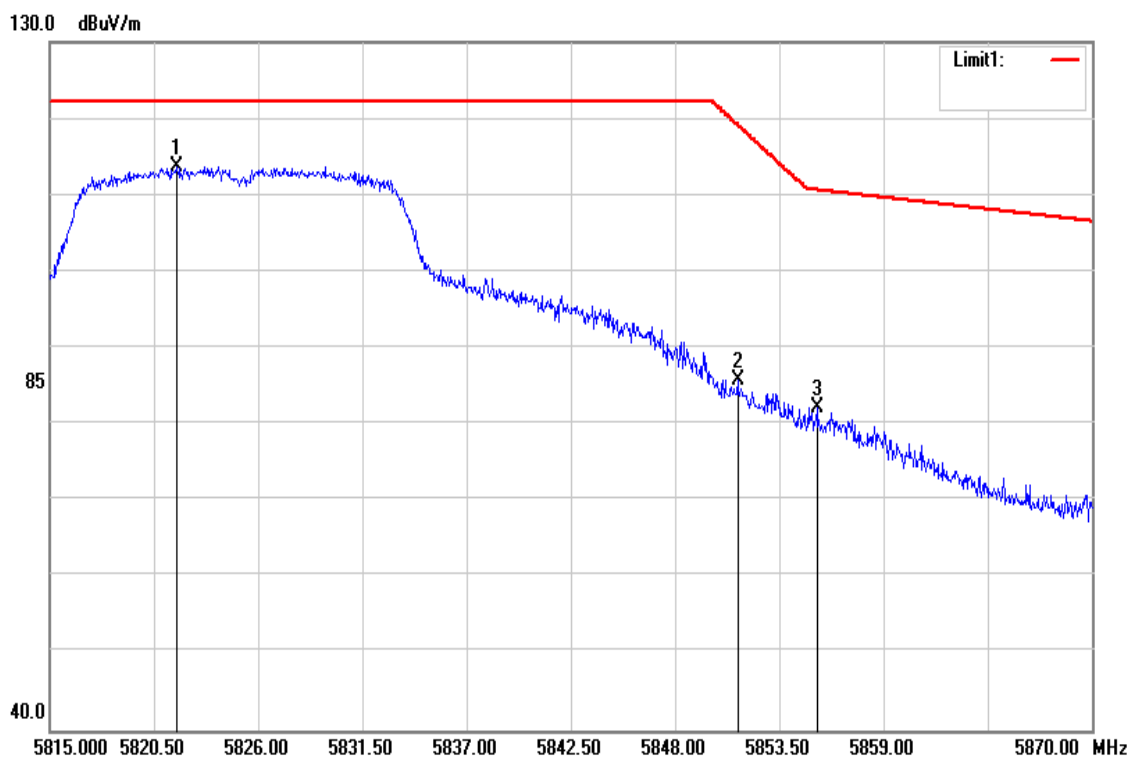

Frequency (MHz)	Reading (dBuV)	Correct Factor (dB/m)	Result (dBuV/m)	Limit (dBuV/m)	Margin (dB)	Remark
5821.710	107.03	6.77	113.80	-	-	peak
5851.300	78.97	6.85	85.82	119.24	-33.42	peak
5855.480	75.24	6.86	82.10	110.67	-28.57	peak

Report No.: T180627D11-RP4

Test Mode	IEEE 802.11n HT20 / 5825 MHz	Temp/Hum	22(°C)/ 34%RH
Test Item	Band Edge	Test Date	July 16, 2018
Polarize	Vertical	Test Engineer	Jerry Chuang
Detector	Average		

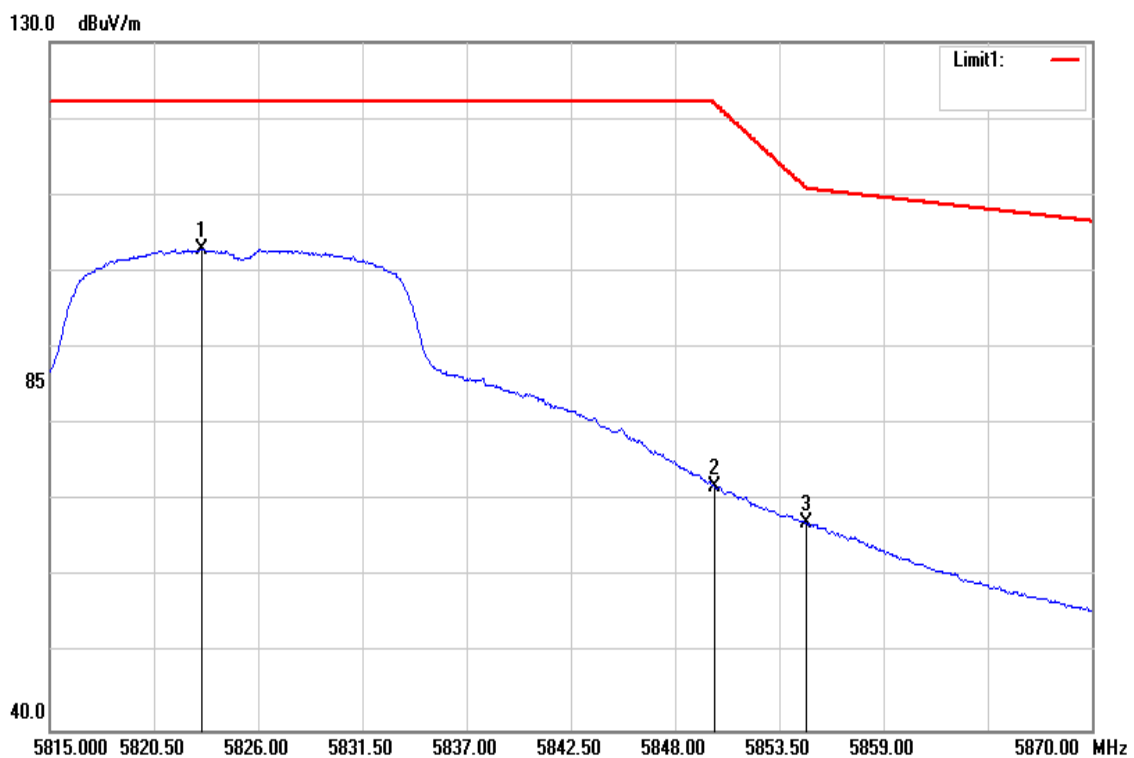

Frequency (MHz)	Reading (dBuV)	Correct Factor (dB/m)	Result (dBuV/m)	Limit (dBuV/m)	Margin (dB)	Remark
5823.030	96.10	6.78	102.88	-	-	AVG
5850.090	65.03	6.85	71.88	121.99	-50.11	AVG
5854.930	60.31	6.86	67.17	110.96	-43.79	AVG

Test Mode	IEEE 802.11n HT40/ 5755 MHz	Temp/Hum	22(°C)/ 34%RH
Test Item	Band Edge	Test Date	July 16, 2018
Polarize	Vertical	Test Engineer	Jerry Chuang
Detector	Peak		

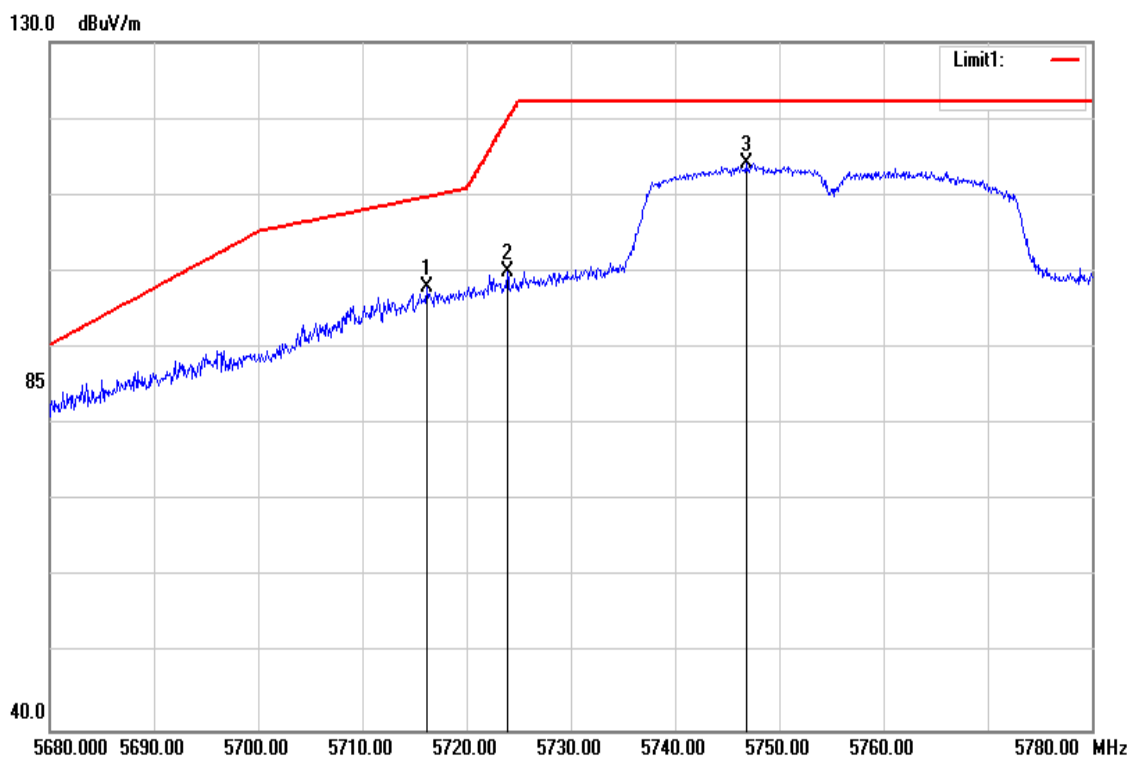

Frequency (MHz)	Reading (dBuV)	Correct Factor (dB/m)	Result (dBuV/m)	Limit (dBuV/m)	Margin (dB)	Remark
5716.200	91.44	6.49	97.93	109.74	-11.81	peak
5723.900	93.42	6.52	99.94	119.69	-19.75	peak
5746.800	107.50	6.58	114.08	-	-	peak

Test Mode	IEEE 802.11n HT40/ 5755 MHz	Temp/Hum	22(°C)/ 34%RH
Test Item	Band Edge	Test Date	July 16, 2018
Polarize	Vertical	Test Engineer	Jerry Chuang
Detector	Average		

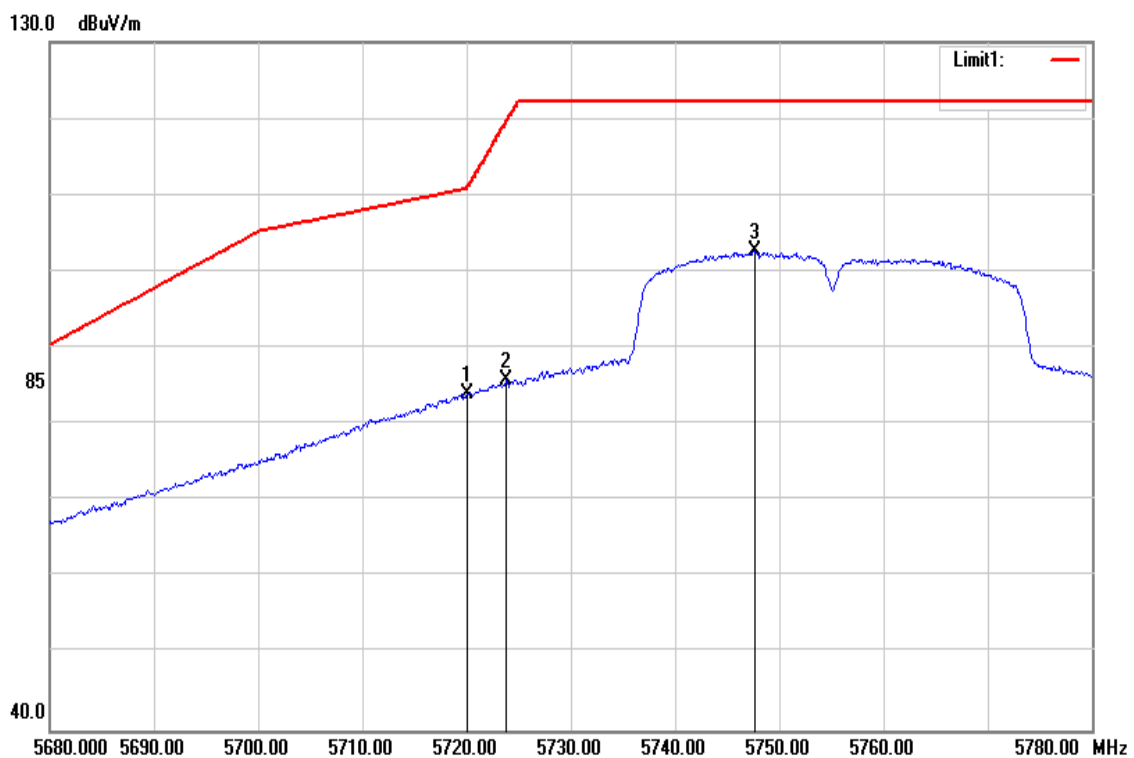

Frequency (MHz)	Reading (dBuV)	Correct Factor (dB/m)	Result (dBuV/m)	Limit (dBuV/m)	Margin (dB)	Remark
5720.100	77.55	6.50	84.05	111.03	-26.98	AVG
5723.800	79.23	6.52	85.75	119.46	-33.71	AVG
5747.600	96.00	6.59	102.59	-	-	AVG

Report No.: T180627D11-RP4

Test Mode	IEEE 802.11n HT40/ 5795 MHz	Temp/Hum	22(°C)/ 34%RH
Test Item	Band Edge	Test Date	July 16, 2018
Polarize	Vertical	Test Engineer	Jerry Chuang
Detector	Peak		

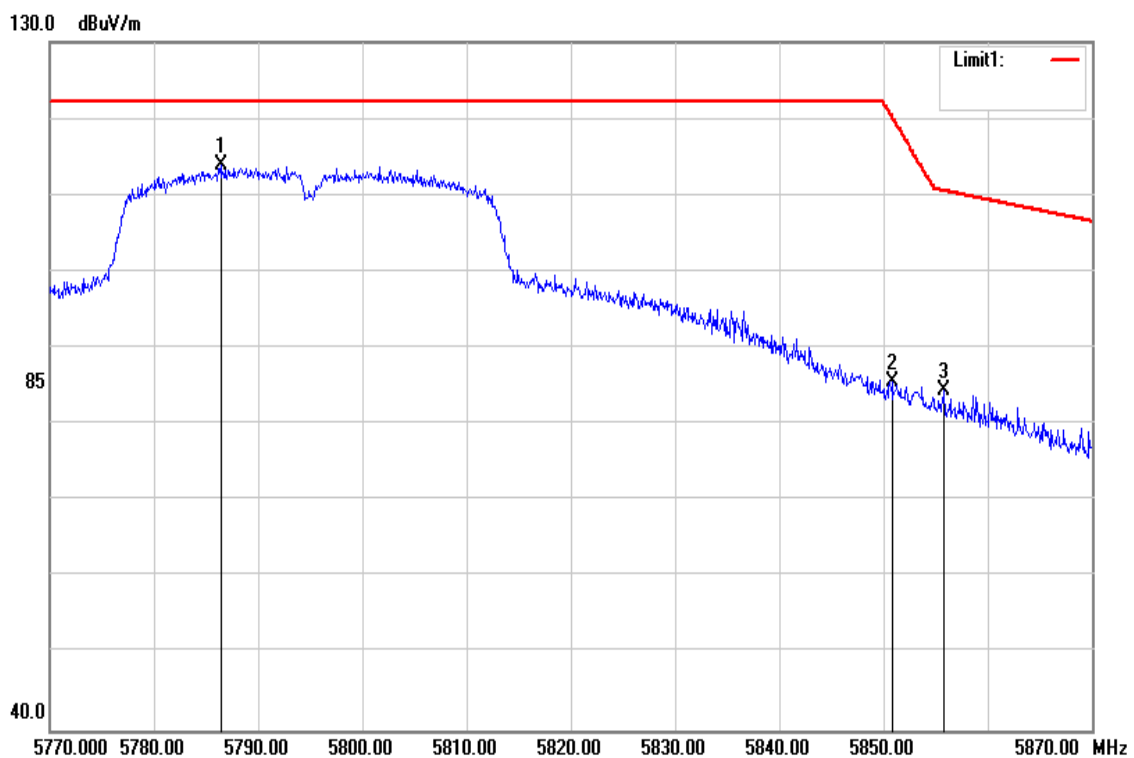

Frequency (MHz)	Reading (dBuV)	Correct Factor (dB/m)	Result (dBuV/m)	Limit (dBuV/m)	Margin (dB)	Remark
5786.400	107.21	6.67	113.88	-	-	peak
5850.800	78.73	6.85	85.58	120.38	-34.80	peak
5855.800	77.54	6.86	84.40	110.58	-26.18	peak

Report No.: T180627D11-RP4

Test Mode	IEEE 802.11n HT40/ 5795 MHz	Temp/Hum	22(°C)/ 34%RH
Test Item	Band Edge	Test Date	July 16, 2018
Polarize	Vertical	Test Engineer	Jerry Chuang
Detector	Average		

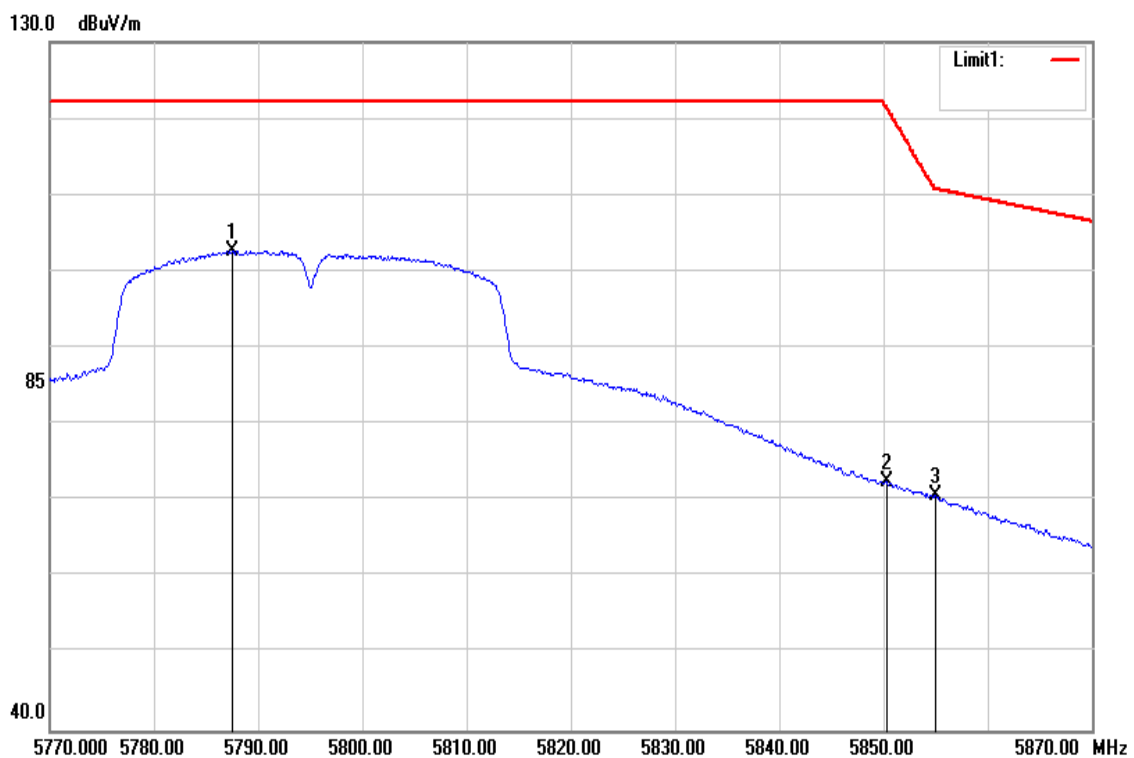

Frequency (MHz)	Reading (dBuV)	Correct Factor (dB/m)	Result (dBuV/m)	Limit (dBuV/m)	Margin (dB)	Remark
5787.500	96.01	6.69	102.70	-	-	AVG
5850.300	65.64	6.85	72.49	121.52	-49.03	AVG
5855.000	63.86	6.86	70.72	110.80	-40.08	AVG

Report No.: T180627D11-RP4

Test Mode	IEEE 802.11ac VHT80 / 5775 MHz	Temp/Hum	22(°C)/ 34%RH
Test Item	Band Edge	Test Date	July 16, 2018
Polarize	Vertical	Test Engineer	Jerry Chuang
Detector	Peak		

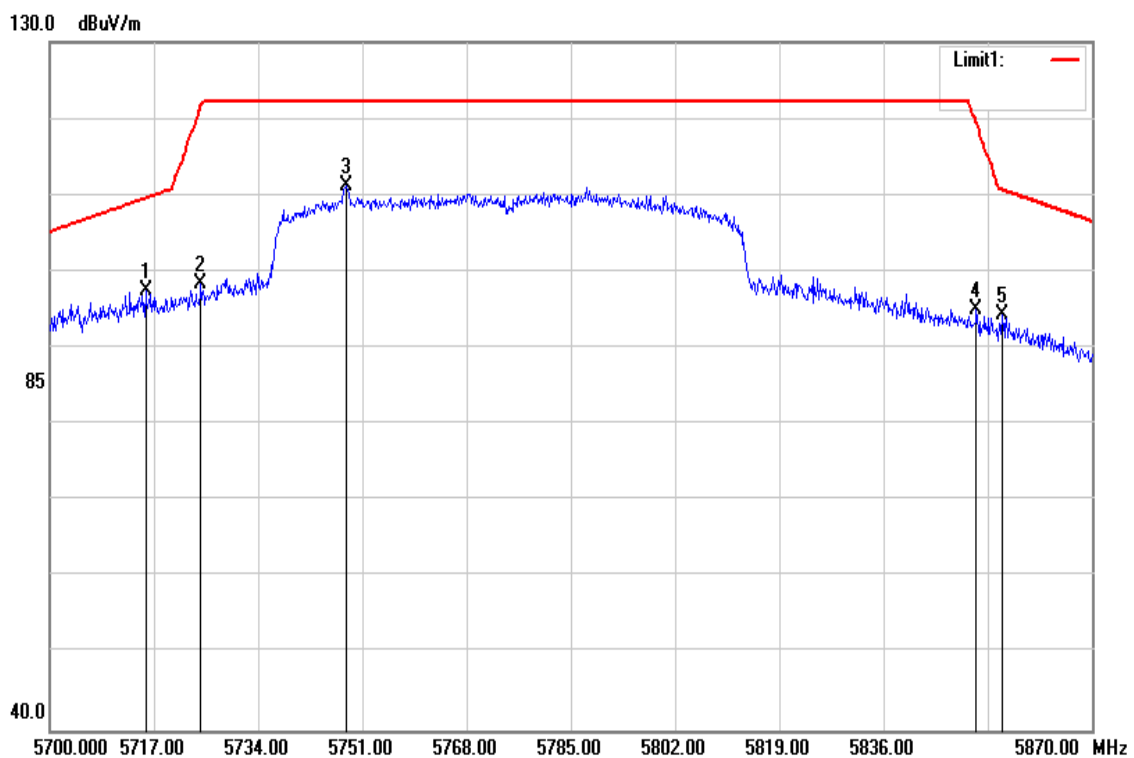

Frequency (MHz)	Reading (dBuV)	Correct Factor (dB/m)	Result (dBuV/m)	Limit (dBuV/m)	Margin (dB)	Remark
5715.640	90.92	6.49	97.41	109.58	-12.17	peak
5724.650	91.82	6.52	98.34	121.40	-23.06	peak
5748.280	104.54	6.59	111.13	-	-	peak
5851.130	88.26	6.85	95.11	119.62	-24.51	peak
5855.380	87.54	6.86	94.40	110.69	-16.29	peak

Report No.: T180627D11-RP4

Test Mode	IEEE 802.11ac VHT80 / 5775 MHz	Temp/Hum	22(°C)/ 34%RH
Test Item	Band Edge	Test Date	July 16, 2018
Polarize	Vertical	Test Engineer	Jerry Chuang
Detector	Average		

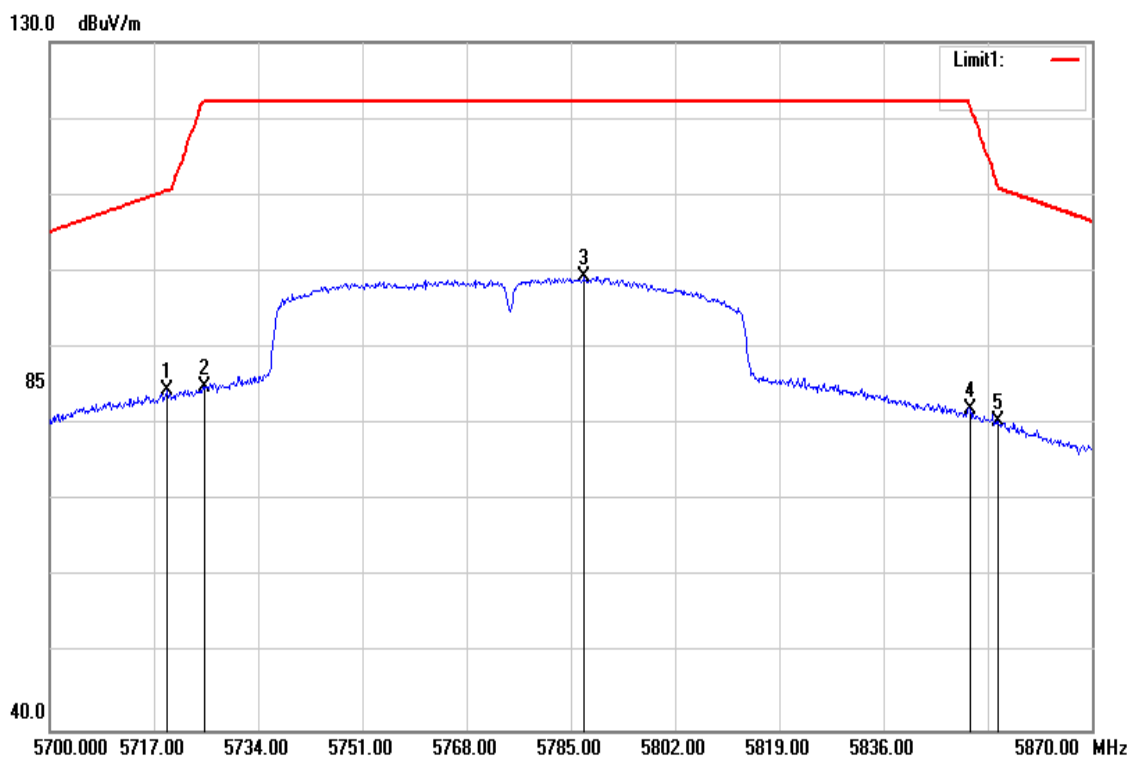

Frequency (MHz)	Reading (dBuV)	Correct Factor (dB/m)	Result (dBuV/m)	Limit (dBuV/m)	Margin (dB)	Remark
5719.210	77.99	6.50	84.49	110.58	-26.09	AVG
5725.160	78.38	6.52	84.90	122.20	-37.30	AVG
5787.210	92.62	6.67	99.29	-	-	AVG
5850.110	75.06	6.85	81.91	121.95	-40.04	AVG
5854.700	73.45	6.86	80.31	111.48	-31.17	AVG

Below 1G Test Data

For PIFA Antenna

Test Mode	IEEE 802.11ac VHT80 / 5210MHZ	Temp/Hum	22(°C)/ 34%RH
Test Item	30MHz-1GHz	Test Date	July 30, 2018
Polarize	Horizontal	Test Engineer	Jerry Chuang
Detector	Peak and Quasi-peak		

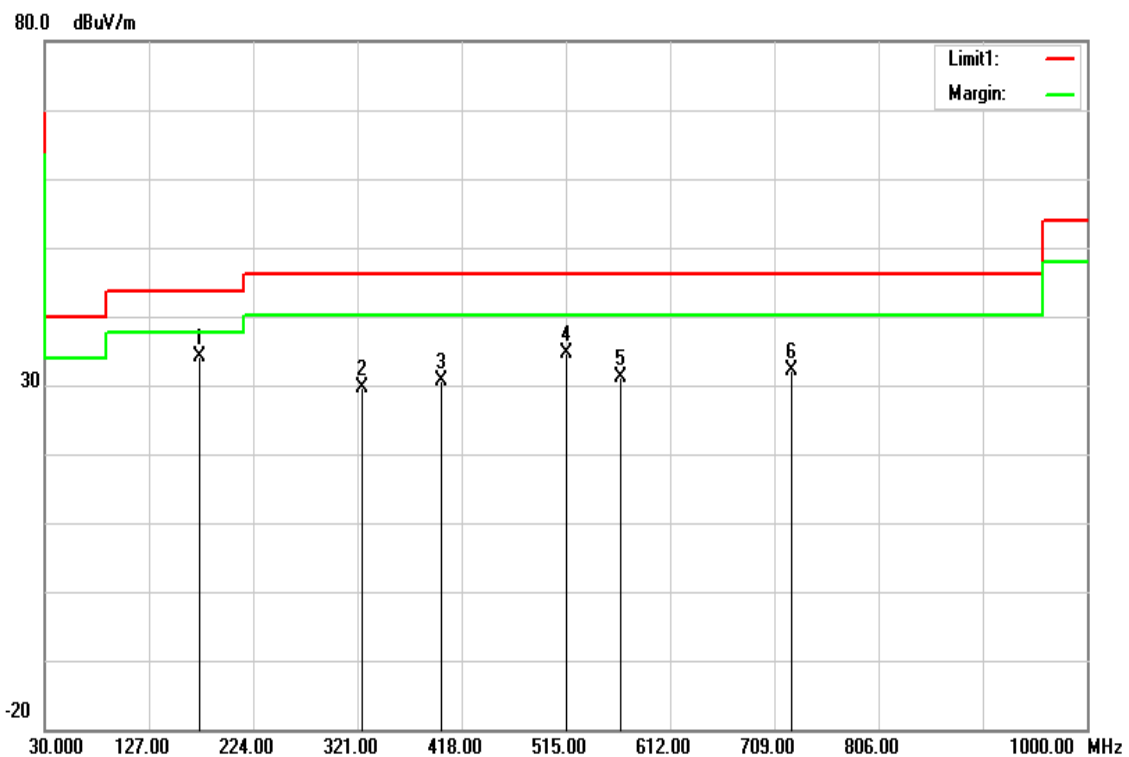

Frequency (MHz)	Reading (dBuV)	Correct Factor (dB/m)	Result (dBuV/m)	Limit (dBuV/m)	Margin (dB)	Remark
174.5300	44.87	-10.78	34.09	43.52	-9.43	peak
324.8800	36.94	-7.38	29.56	46.02	-16.46	peak
399.5700	35.99	-5.30	30.69	46.02	-15.33	peak
515.0000	36.88	-2.33	34.55	46.02	-11.47	peak
565.4400	32.75	-1.56	31.19	46.02	-14.83	peak
724.5200	30.75	1.35	32.10	46.02	-13.92	peak

Test Mode	IEEE 802.11ac VHT80 / 5210MHZ	Temp/Hum	22(°C)/ 34%RH
Test Item	30MHz-1GHz	Test Date	July 30, 2018
Polarize	Horizontal	Test Engineer	Jerry Chuang
Detector	Peak and Quasi-peak		

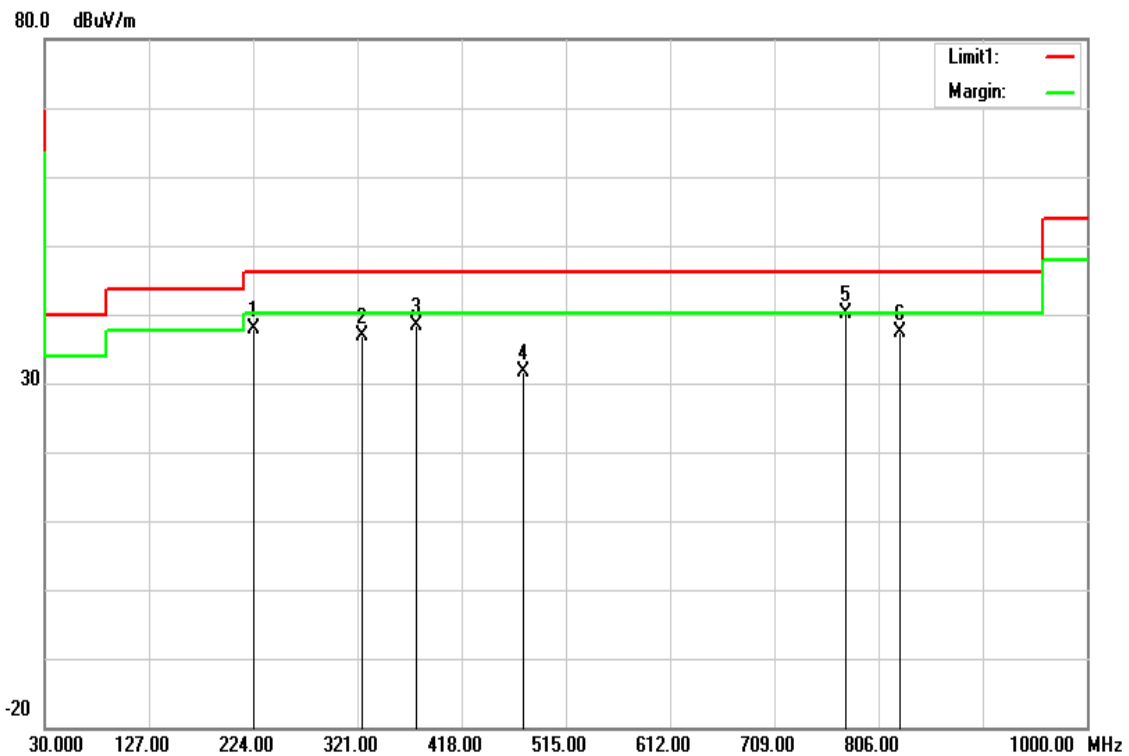

Frequency (MHz)	Reading (dBuV)	Correct Factor (dB/m)	Result (dBuV/m)	Limit (dBuV/m)	Margin (dB)	Remark
224.9700	48.73	-10.97	37.76	46.02	-8.26	peak
324.8800	44.33	-7.38	36.95	46.02	-9.07	peak
375.3200	44.47	-6.02	38.45	46.02	-7.57	peak
475.2300	34.67	-3.14	31.53	46.02	-14.49	peak
774.9600	37.86	2.21	40.07	46.02	-5.95	peak
825.4000	34.36	3.04	37.40	46.02	-8.62	peak

Report No.: T180627D11-RP4

For Dipole Antenna

Test Mode	IEEE 802.11ac VHT80 / 5210MHZ	Temp/Hum	22(°C)/ 34%RH
Test Item	30MHz-1GHz	Test Date	July 30, 2018
Polarize	Horizontal	Test Engineer	Jerry Chuang
Detector	Peak and Quasi-peak		

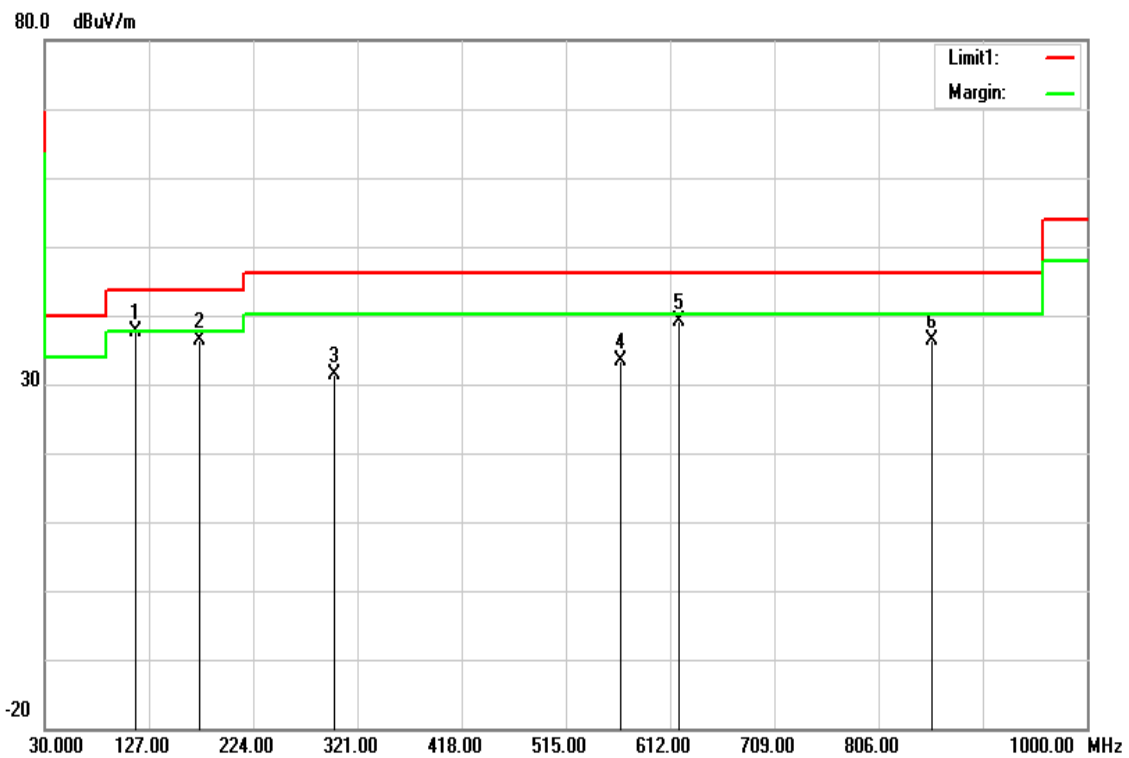

Frequency (MHz)	Reading (dBuV)	Correct Factor (dB/m)	Result (dBuV/m)	Limit (dBuV/m)	Margin (dB)	Remark
114.3900	47.47	-9.96	37.51	43.52	-6.01	peak
174.5300	47.17	-10.78	36.39	43.52	-7.13	peak
299.6600	39.28	-7.97	31.31	46.02	-14.71	peak
565.4400	34.99	-1.56	33.43	46.02	-12.59	peak
619.7600	39.69	-0.55	39.14	46.02	-6.88	peak
855.4700	32.87	3.47	36.34	46.02	-9.68	peak

Report No.: T180627D11-RP4

Test Mode	IEEE 802.11ac VHT80 / 5210MHZ	Temp/Hum	22(°C)/ 34%RH
Test Item	30MHz-1GHz	Test Date	July 30, 2018
Polarize	Horizontal	Test Engineer	Jerry Chuang
Detector	Peak and Quasi-peak		

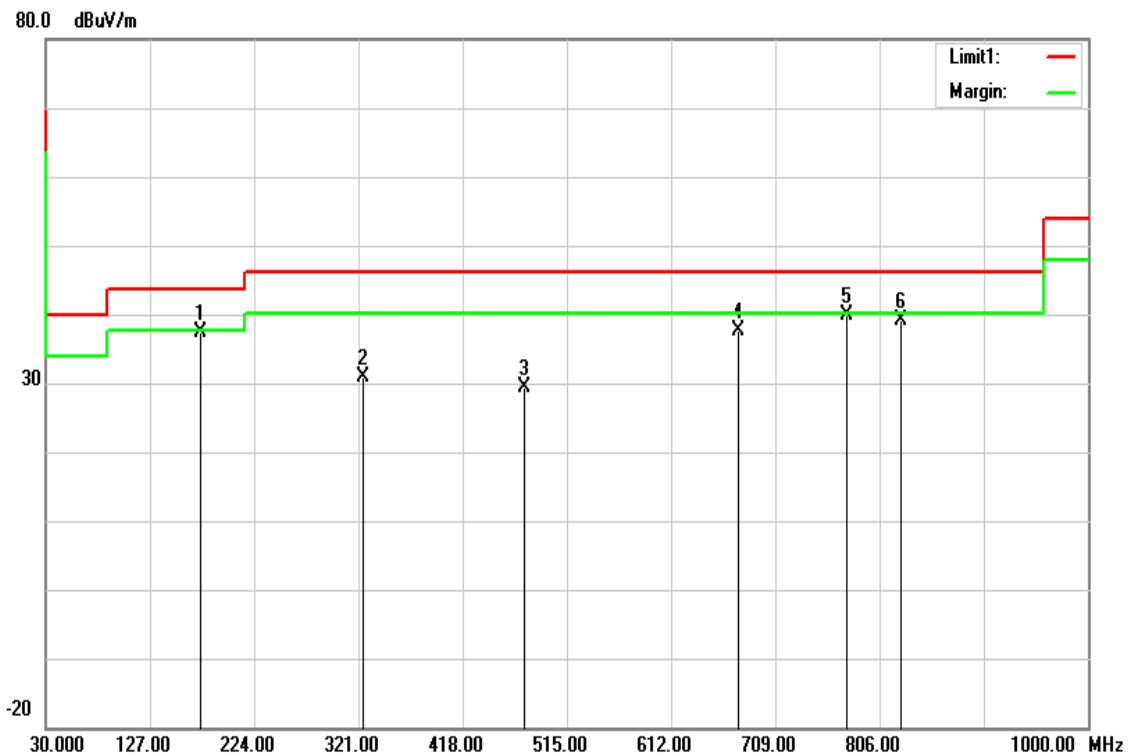

Frequency (MHz)	Reading (dBuV)	Correct Factor (dB/m)	Result (dBuV/m)	Limit (dBuV/m)	Margin (dB)	Remark
174.5300	48.18	-10.78	37.40	43.52	-6.12	peak
324.8800	38.18	-7.38	30.80	46.02	-15.22	peak
475.2300	32.64	-3.14	29.50	46.02	-16.52	peak
675.0500	36.87	0.68	37.55	46.02	-8.47	peak
774.9600	37.62	2.21	39.83	46.02	-6.19	peak
825.4000	36.00	3.04	39.04	46.02	-6.98	peak

Report No.: T180627D11-RP4

For PIFA Antenna

Above 1G Test Data for UNII-1

Test Mode	IEEE 802.11a / 5180MHZ	Temp/Hum	22(°C)/ 34%RH
Test Item	Harmonic	Test Date	July 30, 2018
Polarize	Vertical	Test Engineer	Jerry Chuang
Detector	Peak and Average		

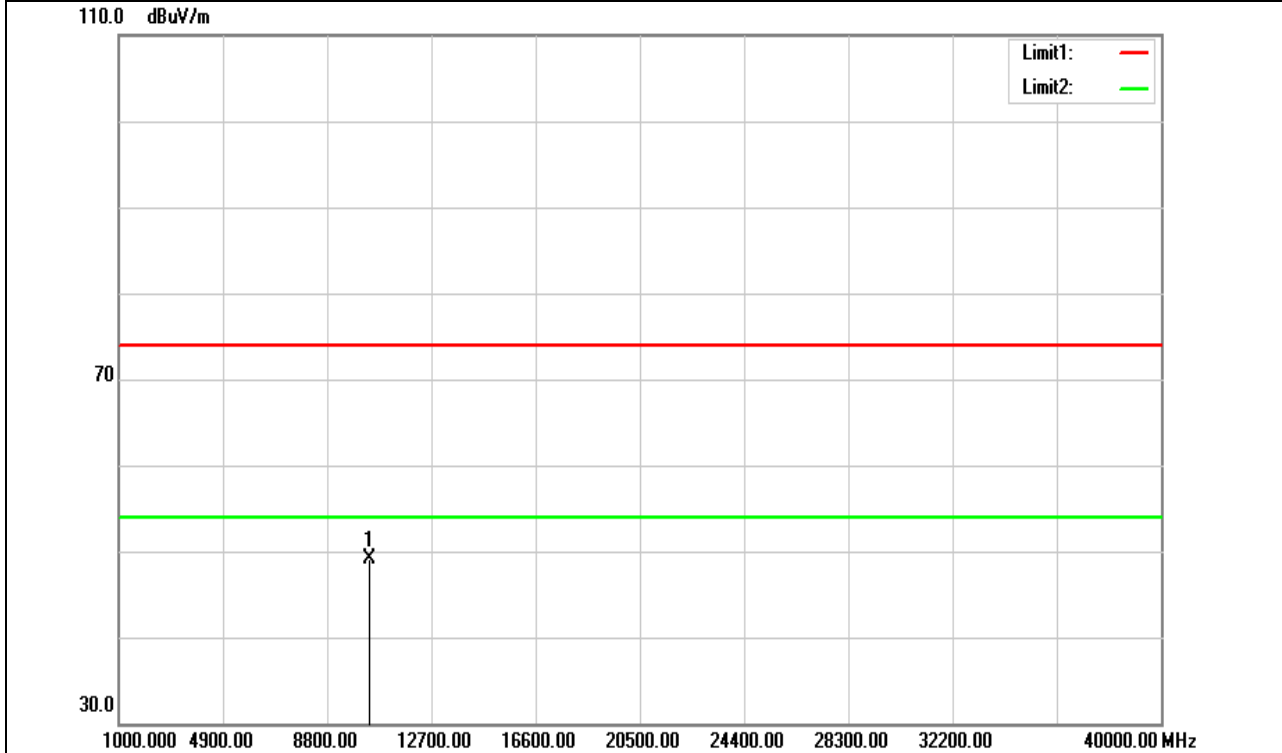

Frequency (MHz)	Reading (dBuV)	Correct Factor (dB/m)	Result (dBuV/m)	Limit (dBuV/m)	Margin (dB)	Remark
10360.000	34.62	14.45	49.07	74.00	-24.93	peak
N/A						

Remark:

1. Measuring frequencies from 1 GHz to the 10th harmonic of highest fundamental frequency.
2. For above 1GHz, the EUT peak value was under average limit, therefore the Average value compliance with the average limit

Test Mode	IEEE 802.11a / 5180MHZ	Temp/Hum	22(°C)/ 34%RH
Test Item	Harmonic	Test Date	July 30, 2018
Polarize	Horizontal	Test Engineer	Jerry Chuang
Detector	Peak and Average		

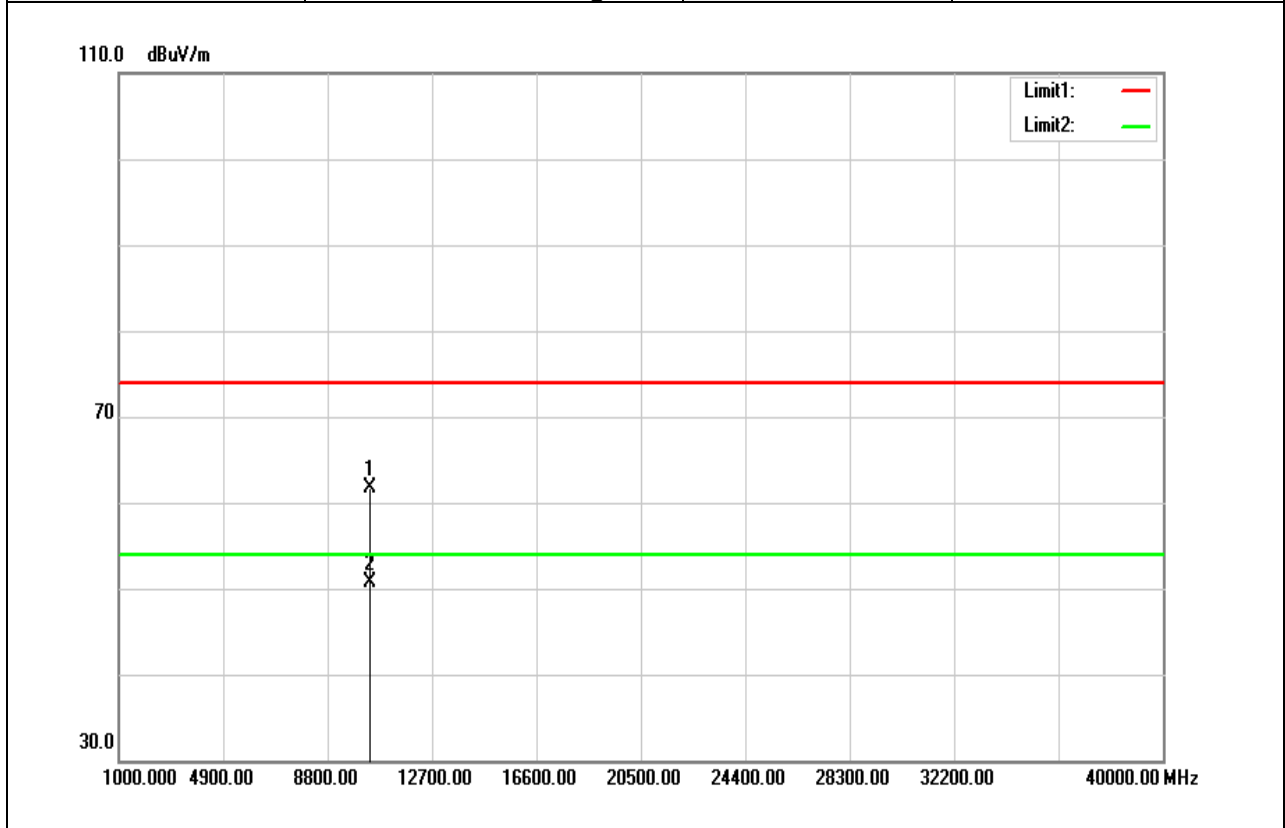

Frequency (MHz)	Reading (dBuV)	Correct Factor (dB/m)	Result (dBuV/m)	Limit (dBuV/m)	Margin (dB)	Remark
10360.000	47.22	14.45	61.67	74.00	-12.33	peak
10360.000	36.22	14.45	50.67	54.00	-3.33	AVG
N/A						

Remark:

1. Measuring frequencies from 1 GHz to the 10th harmonic of highest fundamental frequency.
2. For above 1GHz, the EUT peak value was under average limit, therefore the Average value compliance with the average limit

Report No.: T180627D11-RP4

Test Mode	IEEE 802.11a / 5220 MHZ	Temp/Hum	22(°C)/ 34%RH
Test Item	Horizontal	Test Date	July 30, 2018
Polarize	Vertical	Test Engineer	Jerry Chuang
Detector	Peak and Average		

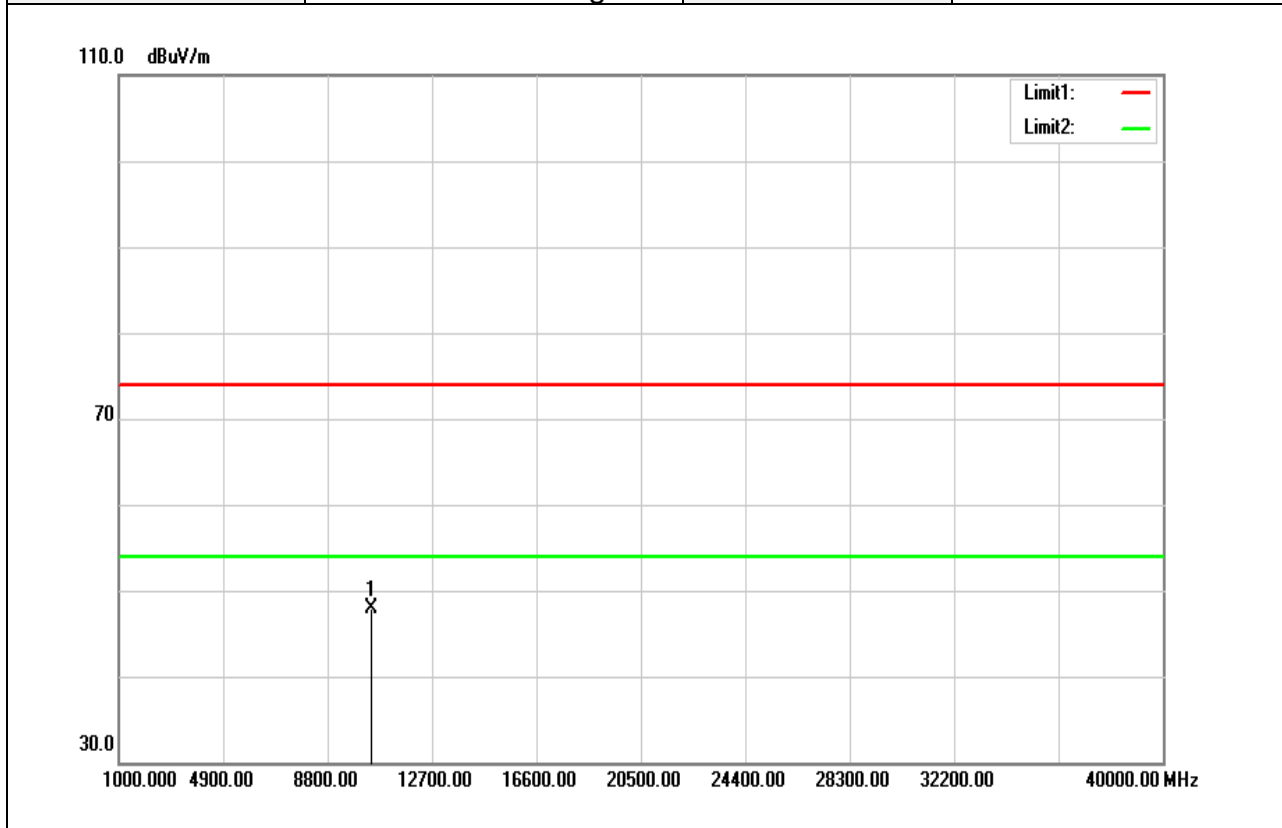

Frequency (MHz)	Reading (dBuV)	Correct Factor (dB/m)	Result (dBuV/m)	Limit (dBuV/m)	Margin (dB)	Remark
10440.000	33.18	14.71	47.89	74.00	-26.11	peak
N/A						

Remark:

1. Measuring frequencies from 1 GHz to the 10th harmonic of highest fundamental frequency.
2. For above 1GHz, the EUT peak value was under average limit, therefore the Average value compliance with the average limit

Report No.: T180627D11-RP4

Test Mode	IEEE 802.11a / 5220 MHz	Temp/Hum	22(°C)/ 34%RH
Test Item	Harmonic	Test Date	July 30, 2018
Polarize	Horizontal	Test Engineer	Jerry Chuang
Detector	Peak and Average		

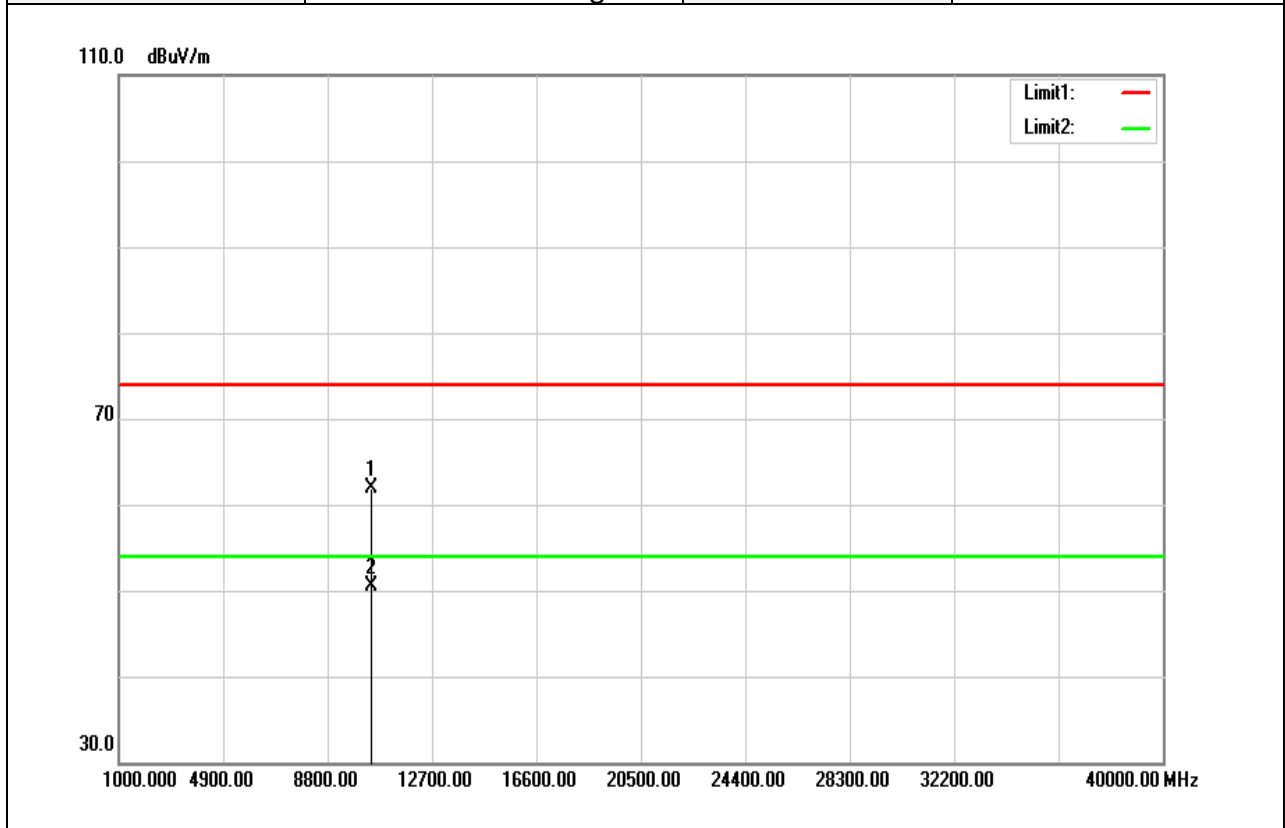

Frequency (MHz)	Reading (dBuV)	Correct Factor (dB/m)	Result (dBuV/m)	Limit (dBuV/m)	Margin (dB)	Remark
10440.000	47.13	14.71	61.84	74.00	-12.16	peak
10440.000	35.80	14.71	50.51	54.00	-3.49	AVG
N/A						

Remark:

1. Measuring frequencies from 1 GHz to the 10th harmonic of highest fundamental frequency.
2. For above 1GHz, the EUT peak value was under average limit, therefore the Average value compliance with the average limit

Report No.: T180627D11-RP4

Test Mode	IEEE 802.11a / 5240MHZ	Temp/Hum	22(°C)/ 34%RH
Test Item	Harmonic	Test Date	July 30, 2018
Polarize	Vertical	Test Engineer	Jerry Chuang
Detector	Peak and Average		

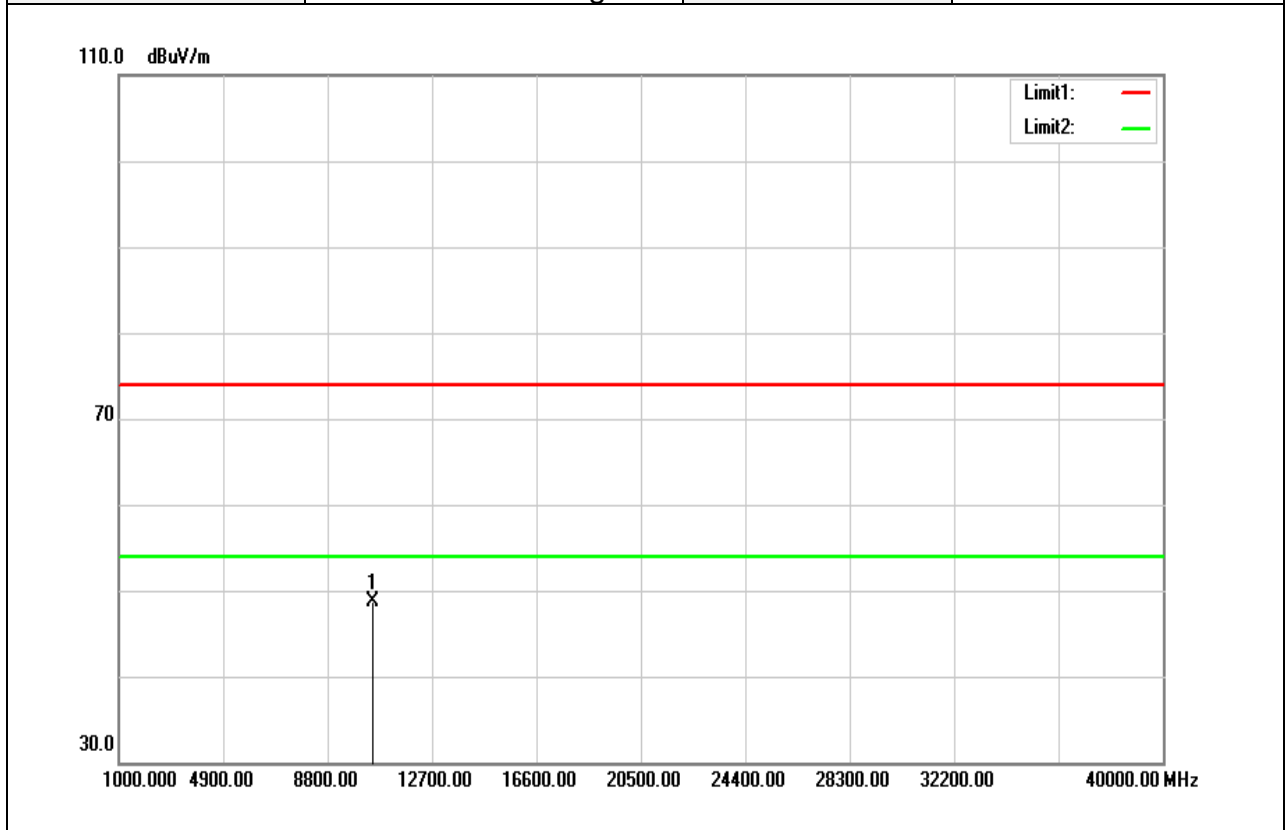

Frequency (MHz)	Reading (dBuV)	Correct Factor (dB/m)	Result (dBuV/m)	Limit (dBuV/m)	Margin (dB)	Remark
10480.000	33.90	14.84	48.74	74.00	-25.26	peak
N/A						

Remark:

1. Measuring frequencies from 1 GHz to the 10th harmonic of highest fundamental frequency.
2. For above 1GHz, the EUT peak value was under average limit, therefore the Average value compliance with the average limit

Report No.: T180627D11-RP4

Test Mode	IEEE 802.11a / 5240MHZ	Temp/Hum	22(°C)/ 34%RH
Test Item	Harmonic	Test Date	July 30, 2018
Polarize	Horizontal	Test Engineer	Jerry Chuang
Detector	Peak and Average		

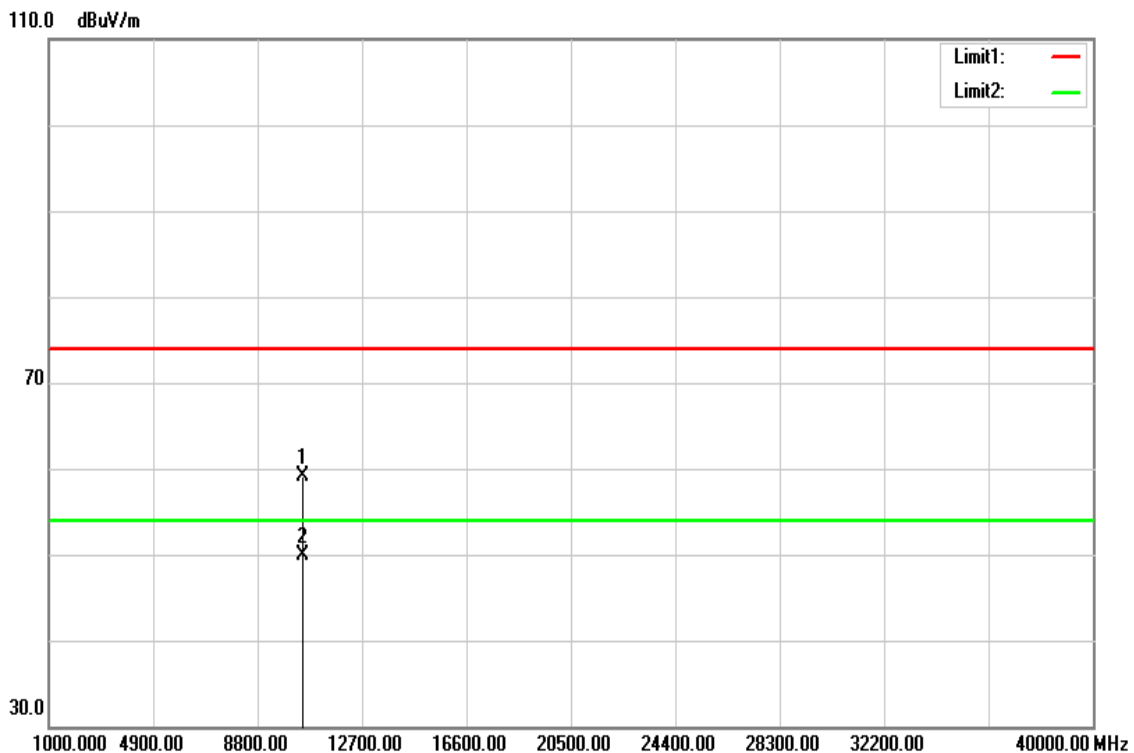

Frequency (MHz)	Reading (dBuV)	Correct Factor (dB/m)	Result (dBuV/m)	Limit (dBuV/m)	Margin (dB)	Remark
10480.000	44.36	14.84	59.20	74.00	-14.80	peak
10480.000	35.12	14.84	49.96	54.00	-4.04	AVG
N/A						

Remark:

1. Measuring frequencies from 1 GHz to the 10th harmonic of highest fundamental frequency.
2. For above 1GHz, the EUT peak value was under average limit, therefore the Average value compliance with the average limit

Test Mode	IEEE 802.11n HT20 / 5180MHZ	Temp/Hum	22(°C)/ 34%RH
Test Item	Harmonic	Test Date	July 30, 2018
Polarize	Vertical	Test Engineer	Jerry Chuang
Detector	Peak and Average		

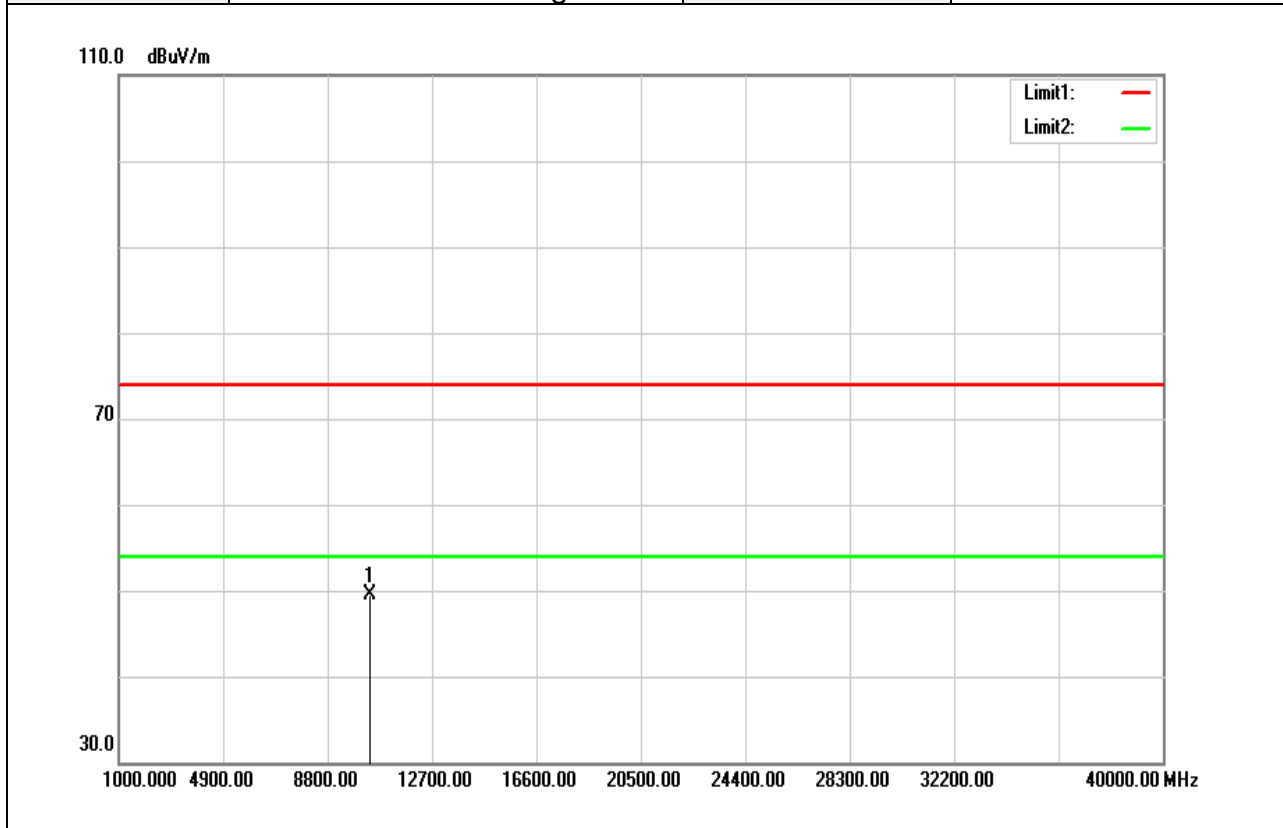

Frequency (MHz)	Reading (dBuV)	Correct Factor (dB/m)	Result (dBuV/m)	Limit (dBuV/m)	Margin (dB)	Remark
10360.000	35.00	14.45	49.45	74.00	-24.55	peak
N/A						

Remark:

1. Measuring frequencies from 1 GHz to the 10th harmonic of highest fundamental frequency.
2. For above 1GHz, the EUT peak value was under average limit, therefore the Average value compliance with the average limit

Test Mode	IEEE 802.11n HT20/ 5180MHZ	Temp/Hum	22(°C)/ 34%RH
Test Item	Harmonic	Test Date	July 30, 2018
Polarize	Horizontal	Test Engineer	Jerry Chuang
Detector	Peak and Average		

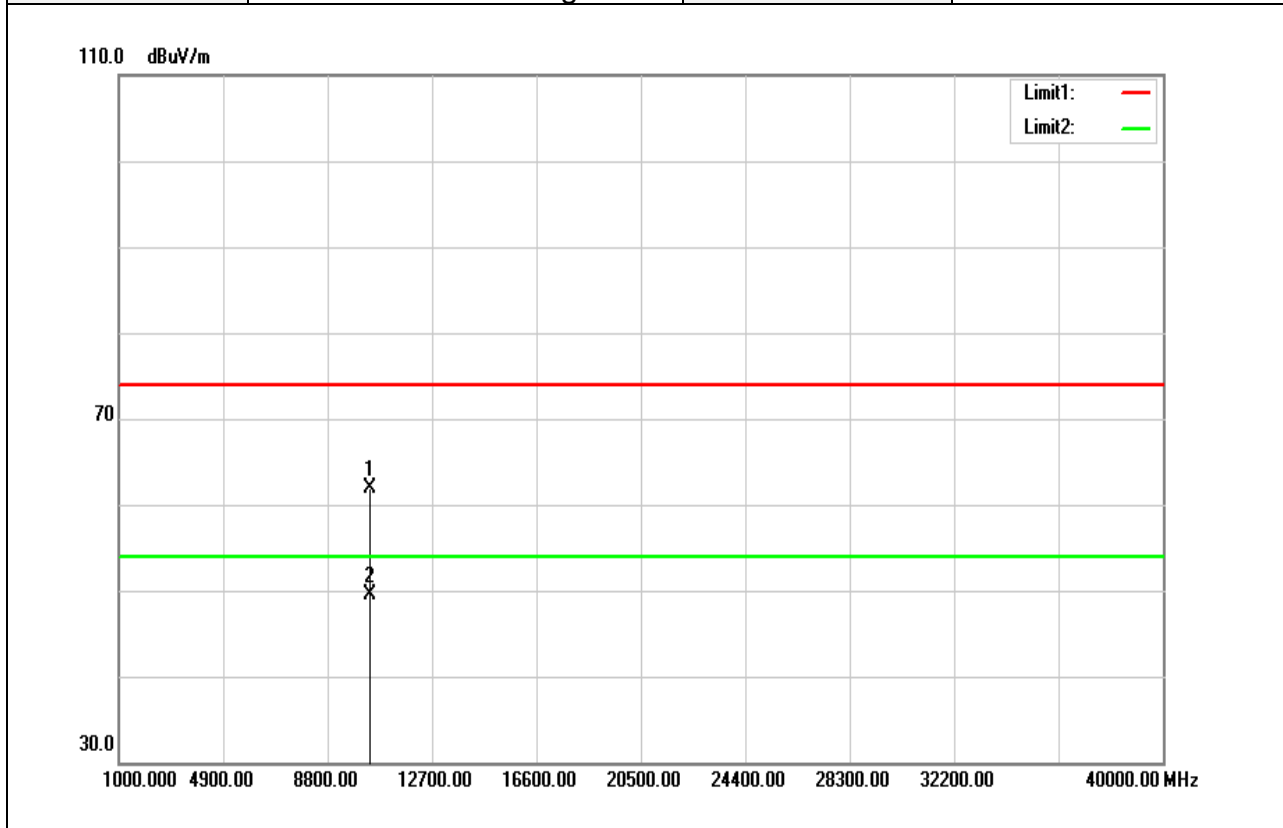

Frequency (MHz)	Reading (dBuV)	Correct Factor (dB/m)	Result (dBuV/m)	Limit (dBuV/m)	Margin (dB)	Remark
10360.000	47.49	14.45	61.94	74.00	-12.06	peak
10360.000	35.10	14.45	49.55	54.00	-4.45	AVG
N/A						

Remark:

1. Measuring frequencies from 1 GHz to the 10th harmonic of highest fundamental frequency.
2. For above 1GHz, the EUT peak value was under average limit, therefore the Average value compliance with the average limit

Report No.: T180627D11-RP4

Test Mode	IEEE 802.11n HT20 / 5220MHZ	Temp/Hum	22(°C)/ 34%RH
Test Item	Harmonic	Test Date	July 30, 2018
Polarize	Vertical	Test Engineer	Jerry Chuang
Detector	Peak and Average		

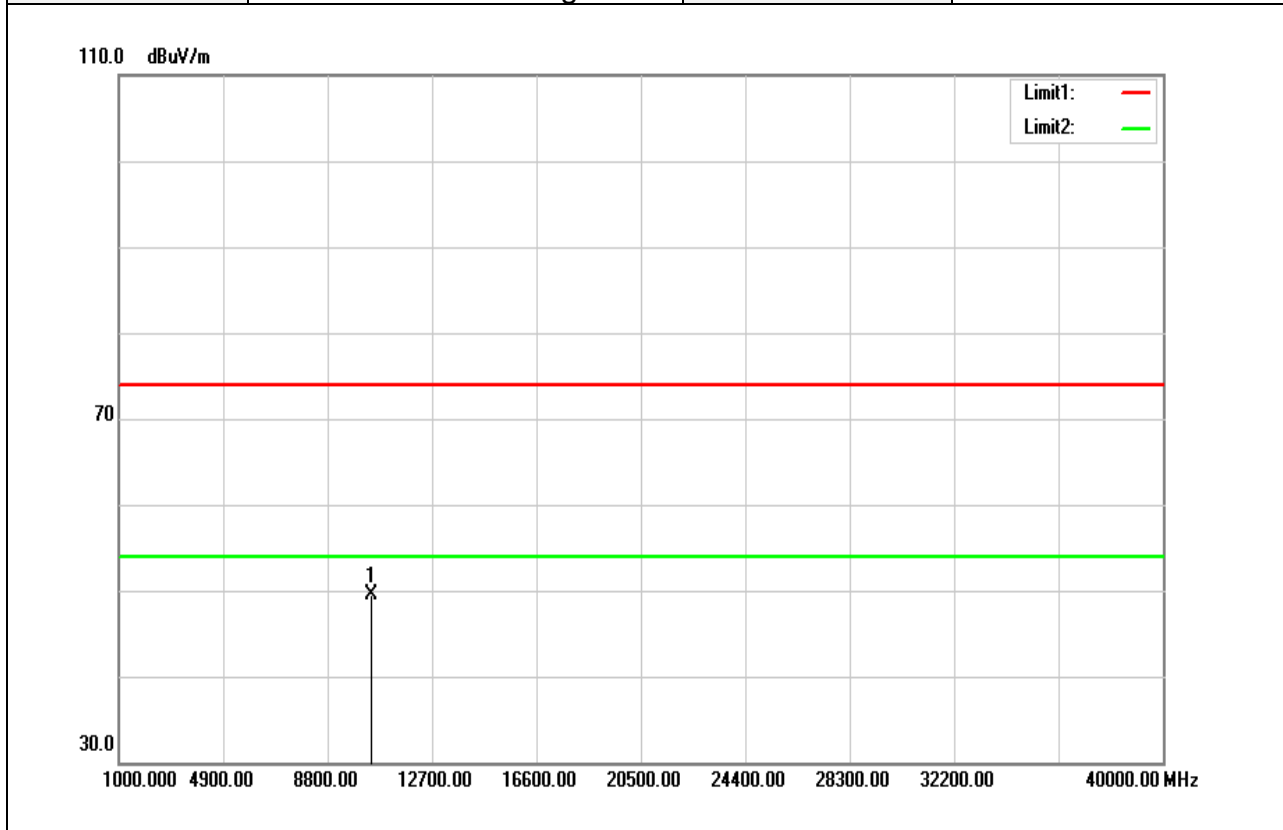

Frequency (MHz)	Reading (dBuV)	Correct Factor (dB/m)	Result (dBuV/m)	Limit (dBuV/m)	Margin (dB)	Remark
10440.000	34.73	14.71	49.44	74.00	-24.56	peak
N/A						

Remark:

1. Measuring frequencies from 1 GHz to the 10th harmonic of highest fundamental frequency.
2. For above 1GHz, the EUT peak value was under average limit, therefore the Average value compliance with the average limit

Test Mode	IEEE 802.11n HT20 / 5220MHZ	Temp/Hum	22(°C)/ 34%RH
Test Item	Harmonic	Test Date	July 30, 2018
Polarize	Horizontal	Test Engineer	Jerry Chuang
Detector	Peak and Average		

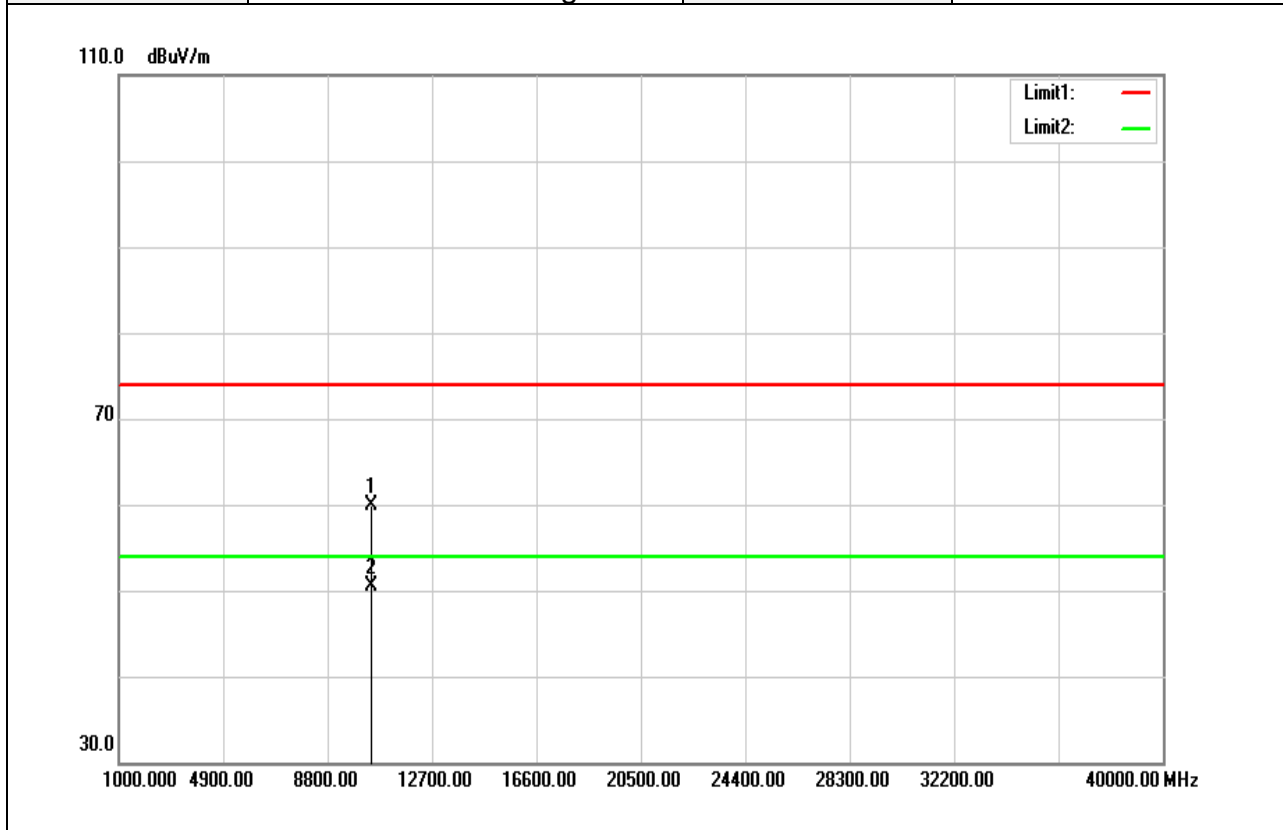

Frequency (MHz)	Reading (dBuV)	Correct Factor (dB/m)	Result (dBuV/m)	Limit (dBuV/m)	Margin (dB)	Remark
10440.000	45.14	14.71	59.85	74.00	-14.15	peak
10440.000	35.85	14.71	50.56	54.00	-3.44	AVG
N/A						

Remark:

1. Measuring frequencies from 1 GHz to the 10th harmonic of highest fundamental frequency.
2. For above 1GHz, the EUT peak value was under average limit, therefore the Average value compliance with the average limit

Test Mode	IEEE 802.11n HT20 / 5240MHZ	Temp/Hum	22(°C)/ 34%RH
Test Item	Harmonic	Test Date	July 30, 2018
Polarize	Vertical	Test Engineer	Jerry Chuang
Detector	Peak and Average		

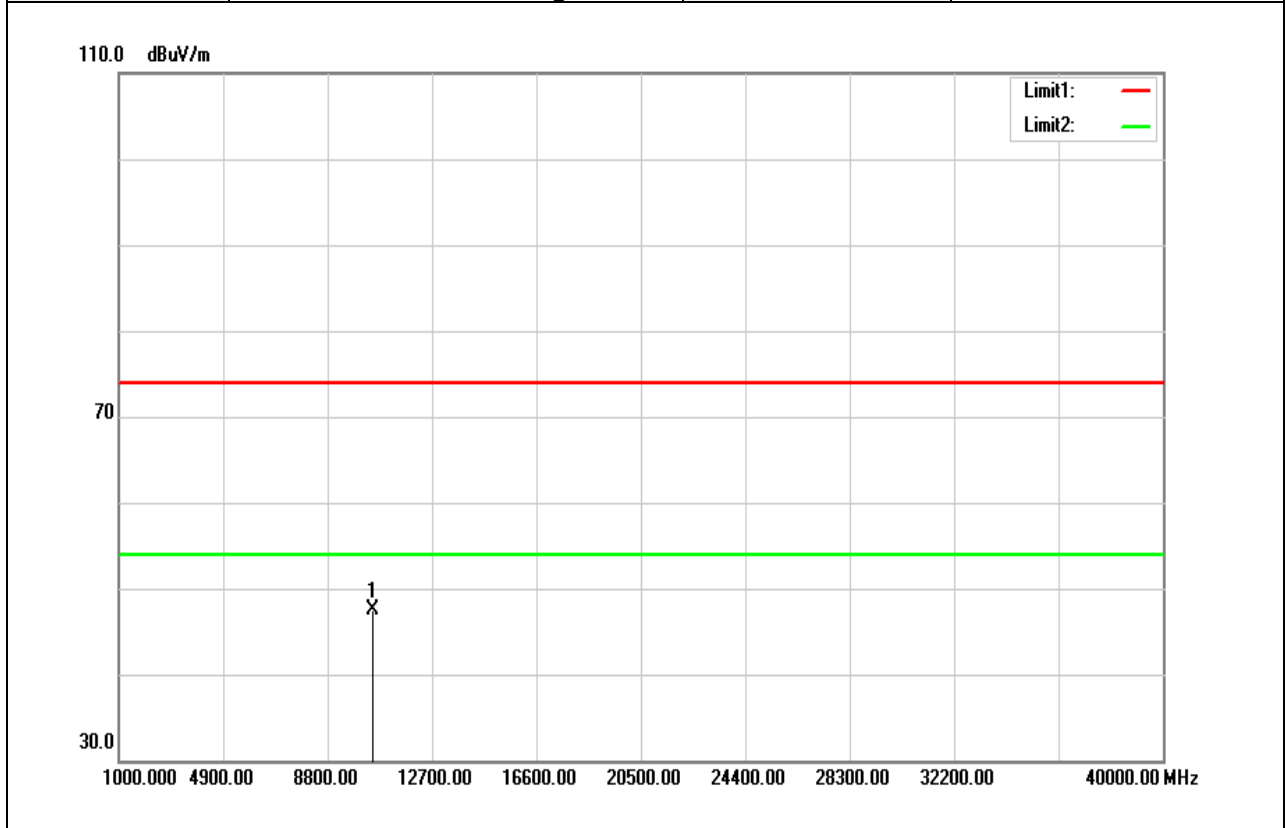

Frequency (MHz)	Reading (dBuV)	Correct Factor (dB/m)	Result (dBuV/m)	Limit (dBuV/m)	Margin (dB)	Remark
10480.000	32.61	14.84	47.45	74.00	-26.55	peak
N/A						

Remark:

1. Measuring frequencies from 1 GHz to the 10th harmonic of highest fundamental frequency.
2. For above 1GHz, the EUT peak value was under average limit, therefore the Average value compliance with the average limit

Report No.: T180627D11-RP4

Test Mode	IEEE 802.11n HT20 / 5240MHZ	Temp/Hum	22(°C)/ 34%RH
Test Item	Harmonic	Test Date	July 30, 2018
Polarize	Horizontal	Test Engineer	Jerry Chuang
Detector	Peak and Average		

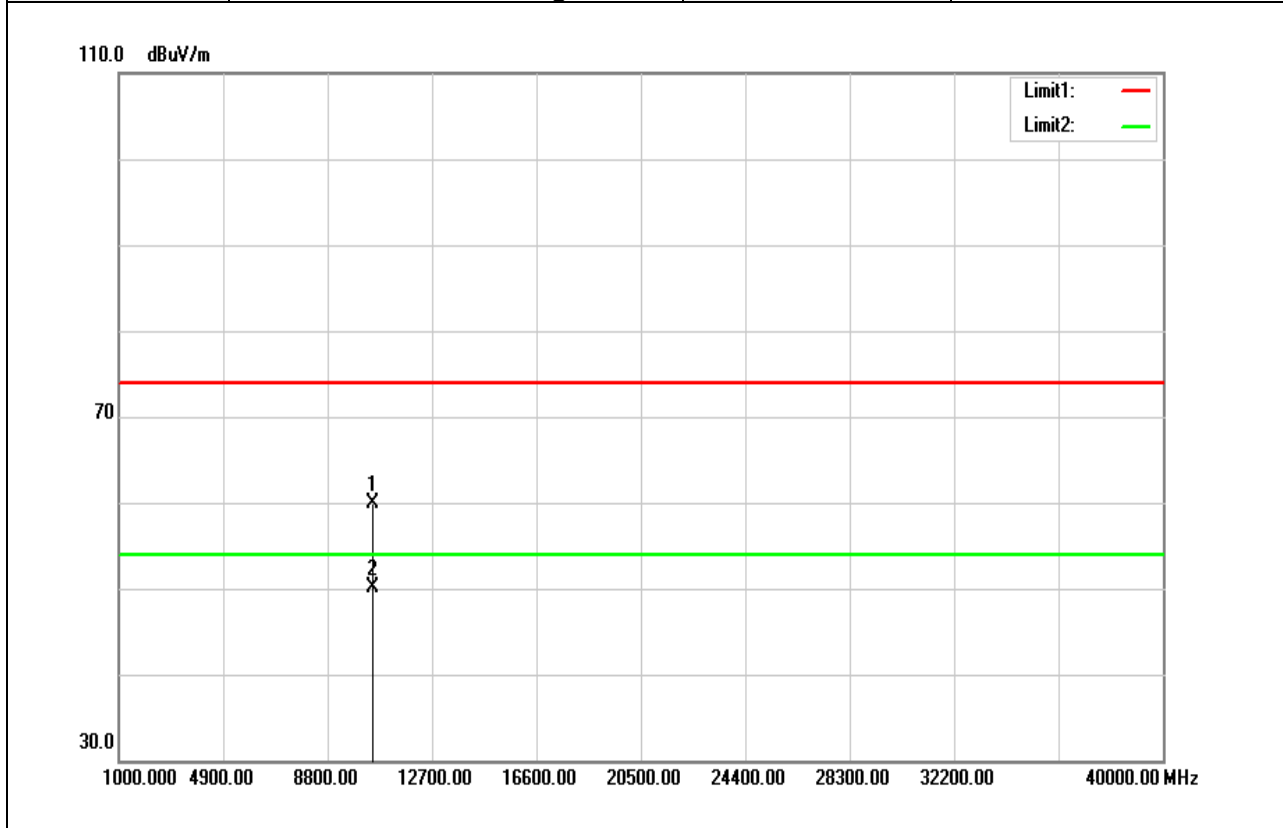

Frequency (MHz)	Reading (dBuV)	Correct Factor (dB/m)	Result (dBuV/m)	Limit (dBuV/m)	Margin (dB)	Remark
10480.000	44.98	14.84	59.82	74.00	-14.18	peak
10480.000	35.29	14.84	50.13	54.00	-3.87	AVG
N/A						

Remark:

1. Measuring frequencies from 1 GHz to the 10th harmonic of highest fundamental frequency.
2. For above 1GHz, the EUT peak value was under average limit, therefore the Average value compliance with the average limit

Test Mode	IEEE 802.11n HT40 / 5190MHZ	Temp/Hum	22(°C)/ 34%RH
Test Item	Harmonic	Test Date	July 30, 2018
Polarize	Vertical	Test Engineer	Jerry Chuang
Detector	Peak and Average		

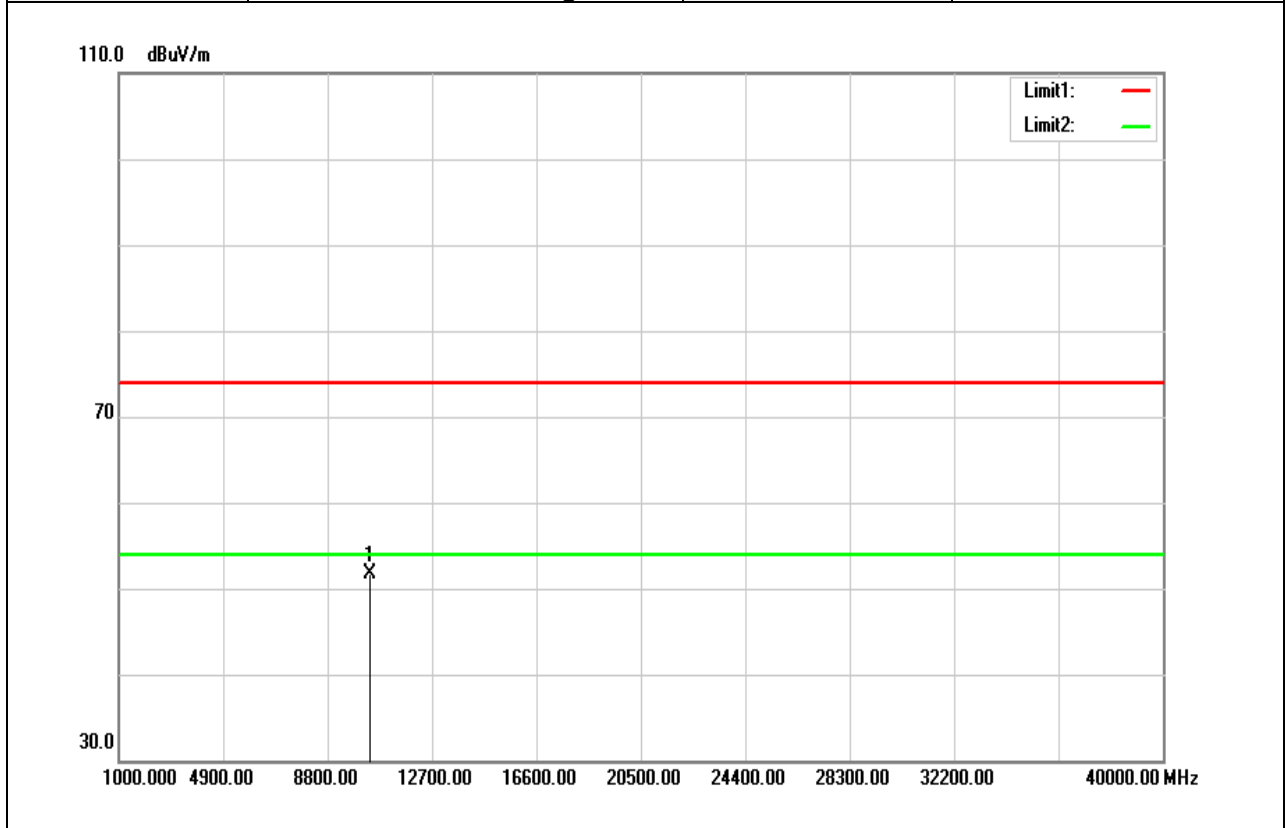

Frequency (MHz)	Reading (dBuV)	Correct Factor (dB/m)	Result (dBuV/m)	Limit (dBuV/m)	Margin (dB)	Remark
10390.000	37.16	14.54	51.70	74.00	-22.30	peak
N/A						

Remark:

1. Measuring frequencies from 1 GHz to the 10th harmonic of highest fundamental frequency.
2. For above 1GHz, the EUT peak value was under average limit, therefore the Average value compliance with the average limit

Report No.: T180627D11-RP4

Test Mode	IEEE 802.11n HT40 / 5190MHZ	Temp/Hum	22(°C)/ 34%RH
Test Item	Harmonic	Test Date	July 30, 2018
Polarize	Horizontal	Test Engineer	Jerry Chuang
Detector	Peak and Average		

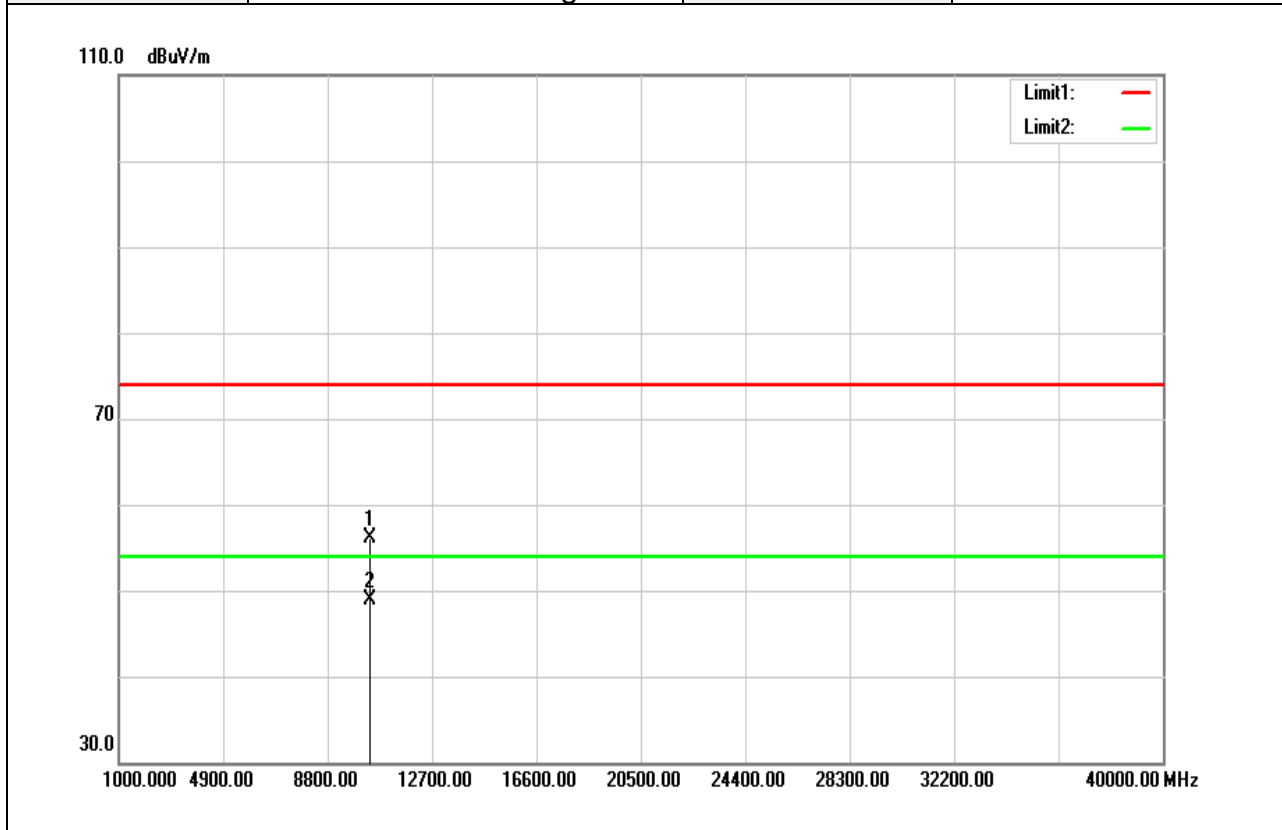

Frequency (MHz)	Reading (dBuV)	Correct Factor (dB/m)	Result (dBuV/m)	Limit (dBuV/m)	Margin (dB)	Remark
10360.000	41.73	14.45	56.18	74.00	-17.82	peak
10360.000	34.37	14.45	48.82	54.00	-5.18	AVG
N/A						

Remark:

- Measuring frequencies from 1 GHz to the 10th harmonic of highest fundamental frequency.
- For above 1GHz, the EUT peak value was under average limit, therefore the Average value compliance with the average limit

Report No.: T180627D11-RP4

Test Mode	IEEE 802.11n HT40 / 5230MHZ	Temp/Hum	22(°C)/ 34%RH
Test Item	Harmonic	Test Date	July 30, 2018
Polarize	Vertical	Test Engineer	Jerry Chuang
Detector	Peak and Average		

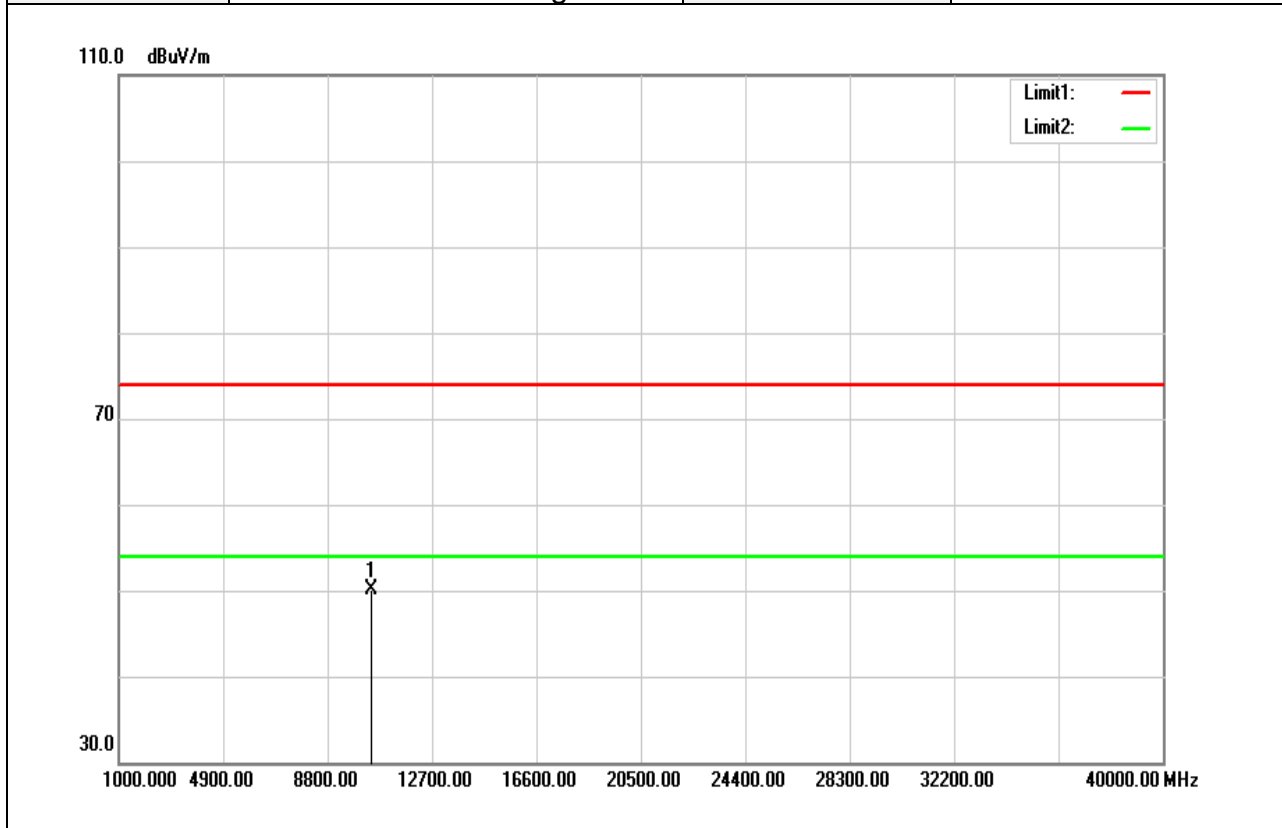

Frequency (MHz)	Reading (dBuV)	Correct Factor (dB/m)	Result (dBuV/m)	Limit (dBuV/m)	Margin (dB)	Remark
10460.000	35.28	14.79	50.07	74.00	-23.93	peak
N/A						

Remark:

1. Measuring frequencies from 1 GHz to the 10th harmonic of highest fundamental frequency.
2. For above 1GHz, the EUT peak value was under average limit, therefore the Average value compliance with the average limit

Report No.: T180627D11-RP4

Test Mode	IEEE 802.11n HT40 / 5230MHZ	Temp/Hum	22(°C)/ 34%RH
Test Item	Harmonic	Test Date	July 30, 2018
Polarize	Horizontal	Test Engineer	Jerry Chuang
Detector	Peak and Average		

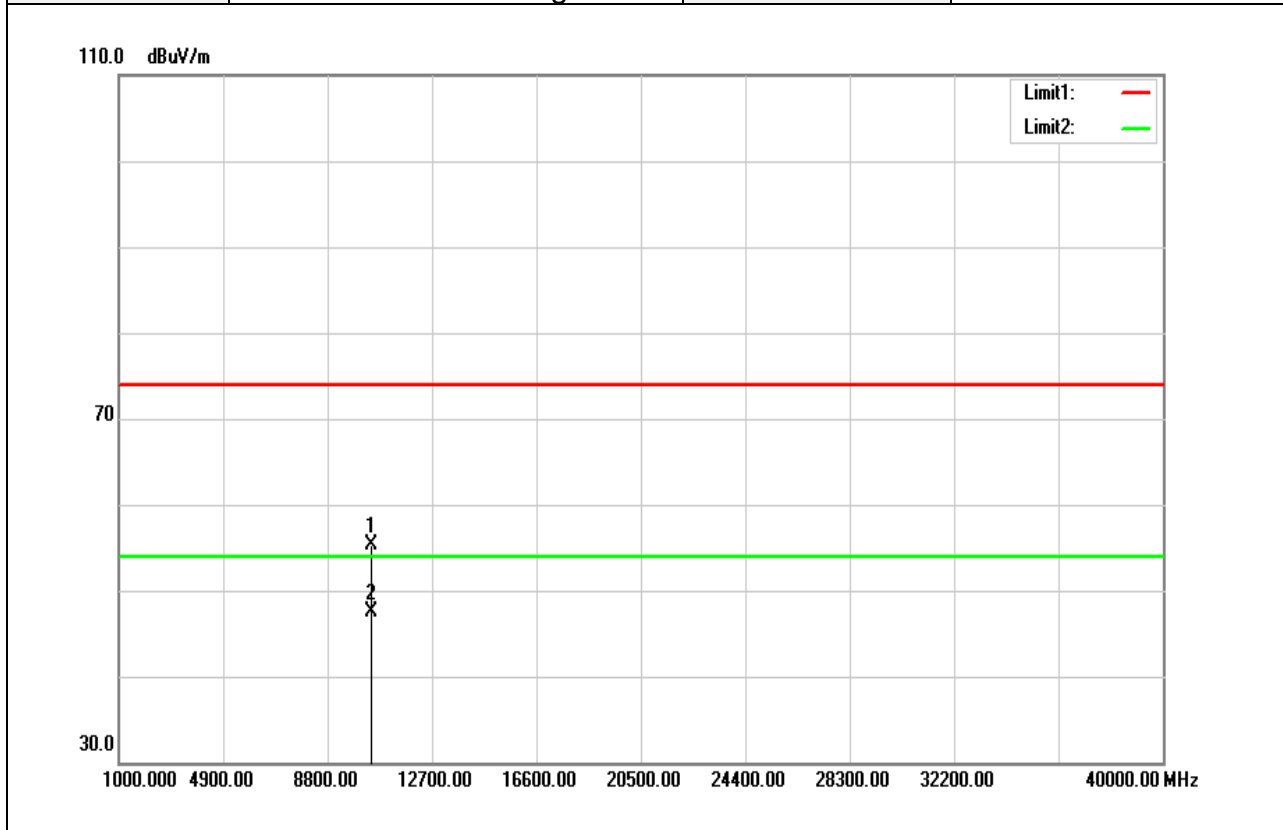

Frequency (MHz)	Reading (dBuV)	Correct Factor (dB/m)	Result (dBuV/m)	Limit (dBuV/m)	Margin (dB)	Remark
10450.000	40.50	14.75	55.25	74.00	-18.75	peak
10450.000	32.74	14.75	47.49	54.00	-6.51	AVG
N/A						

Remark:

1. Measuring frequencies from 1 GHz to the 10th harmonic of highest fundamental frequency.
2. For above 1GHz, the EUT peak value was under average limit, therefore the Average value compliance with the average limit

Test Mode	IEEE 802.11ac VHT80 / 5210MHZ	Temp/Hum	22(°C)/ 34%RH
Test Item	Harmonic	Test Date	July 30, 2018
Polarize	Vertical	Test Engineer	Jerry Chuang
Detector	Peak and Average		

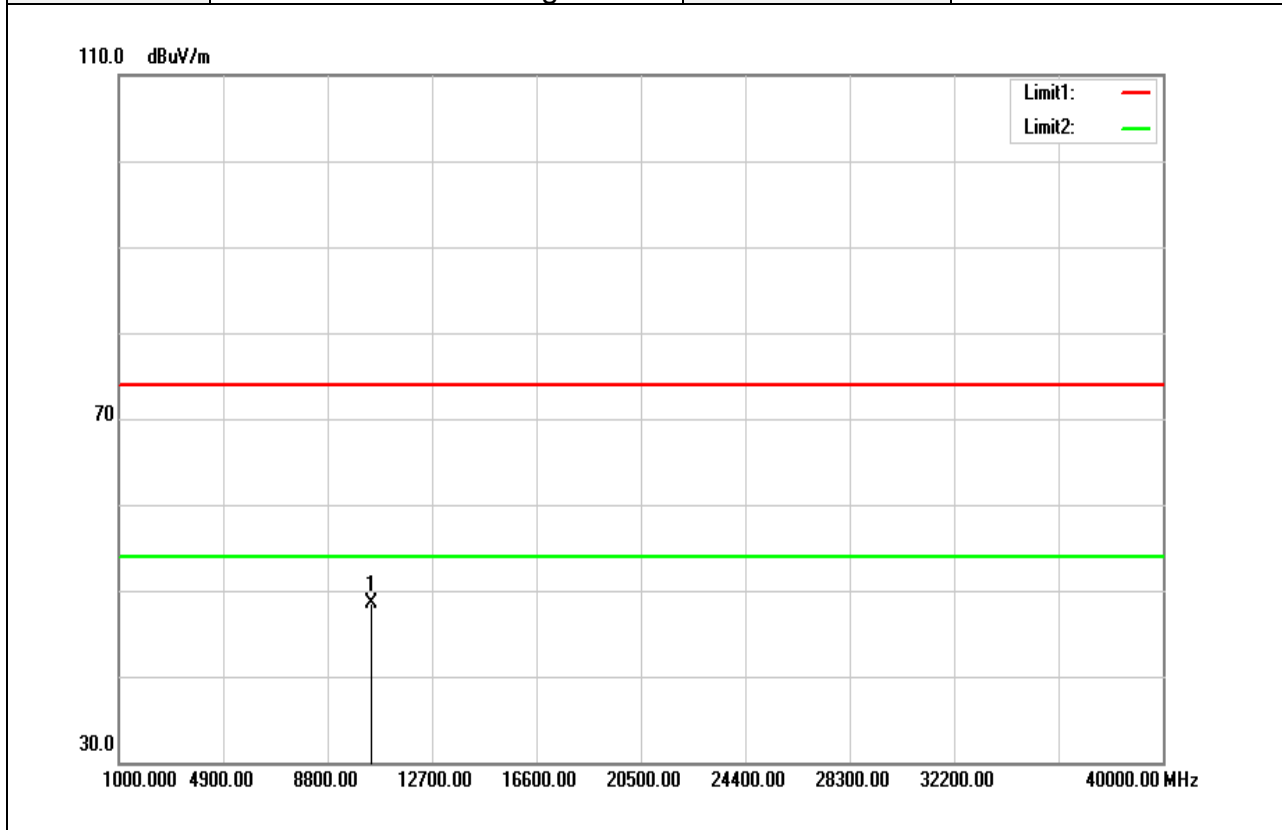

Frequency (MHz)	Reading (dBuV)	Correct Factor (dB/m)	Result (dBuV/m)	Limit (dBuV/m)	Margin (dB)	Remark
10420.000	33.92	14.66	48.58	74.00	-25.42	peak
N/A						

Remark:

1. Measuring frequencies from 1 GHz to the 10th harmonic of highest fundamental frequency.
2. For above 1GHz, the EUT peak value was under average limit, therefore the Average value compliance with the average limit

Test Mode	IEEE 802.11ac VHT80 / 5210MHZ	Temp/Hum	22(°C)/ 34%RH
Test Item	Harmonic	Test Date	July 30, 2018
Polarize	Horizontal	Test Engineer	Jerry Chuang
Detector	Peak and Average		

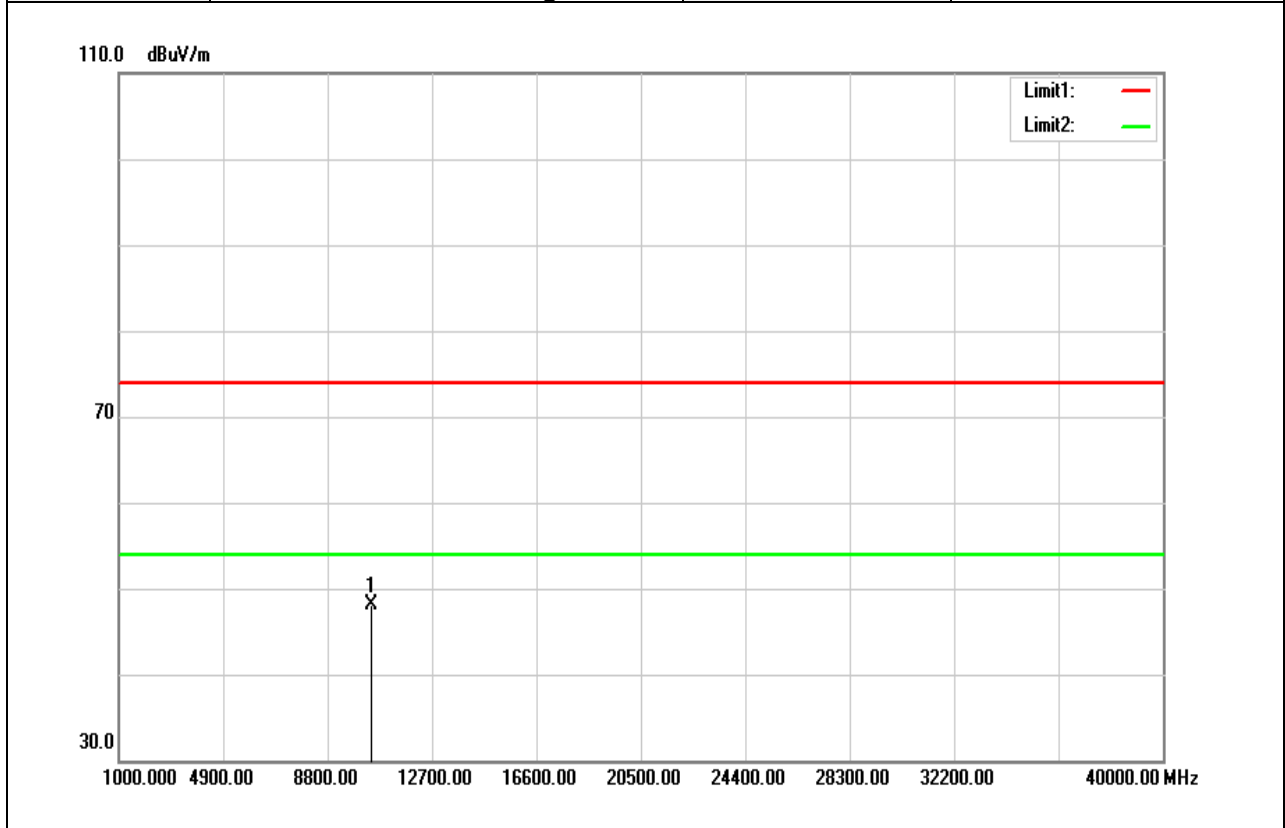

Frequency (MHz)	Reading (dBuV)	Correct Factor (dB/m)	Result (dBuV/m)	Limit (dBuV/m)	Margin (dB)	Remark
10420.000	33.50	14.66	48.16	74.00	-25.84	peak
N/A						

Remark:

1. Measuring frequencies from 1 GHz to the 10th harmonic of highest fundamental frequency.
2. For above 1GHz, the EUT peak value was under average limit, therefore the Average value compliance with the average limit

Above 1G Test Data for UNII-3

Test Mode	IEEE 802.11a / 5745 MHz	Temp/Hum	22(°C)/ 34%RH
Test Item	Harmonic	Test Date	July 30, 2018
Polarize	Vertical	Test Engineer	Jerry Chuang
Detector	Peak and Average		

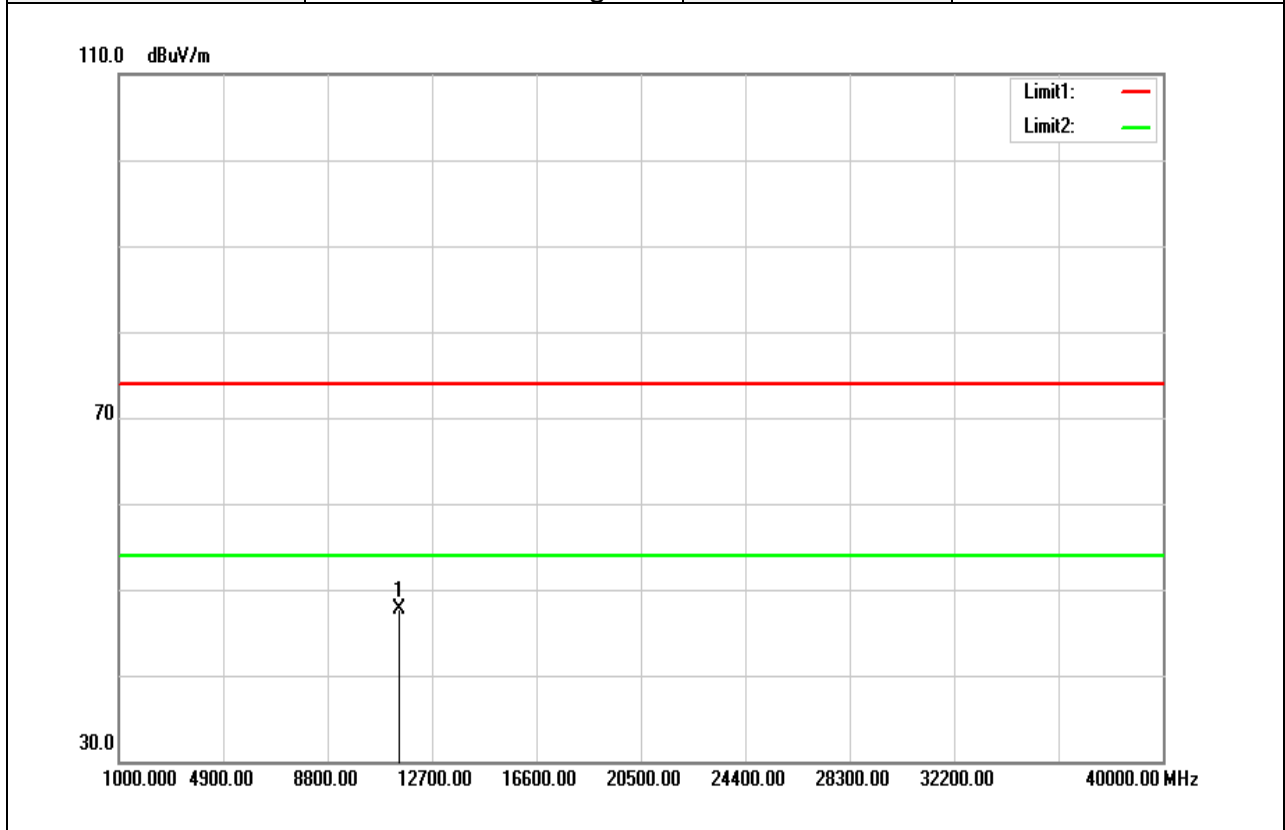

Frequency (MHz)	Reading (dBuV)	Correct Factor (dB/m)	Result (dBuV/m)	Limit (dBuV/m)	Margin (dB)	Remark
11490.000	31.69	16.09	47.78	74.00	-26.22	peak
N/A						

Remark:

1. Measuring frequencies from 1 GHz to the 10th harmonic of highest fundamental frequency.
2. For above 1GHz, the EUT peak value was under average limit, therefore the Average value compliance with the average limit

Report No.: T180627D11-RP4

Test Mode	IEEE 802.11a / 5745 MHz	Temp/Hum	22(°C)/ 34%RH
Test Item	Harmonic	Test Date	July 30, 2018
Polarize	Horizontal	Test Engineer	Jerry Chuang
Detector	Peak and Average		

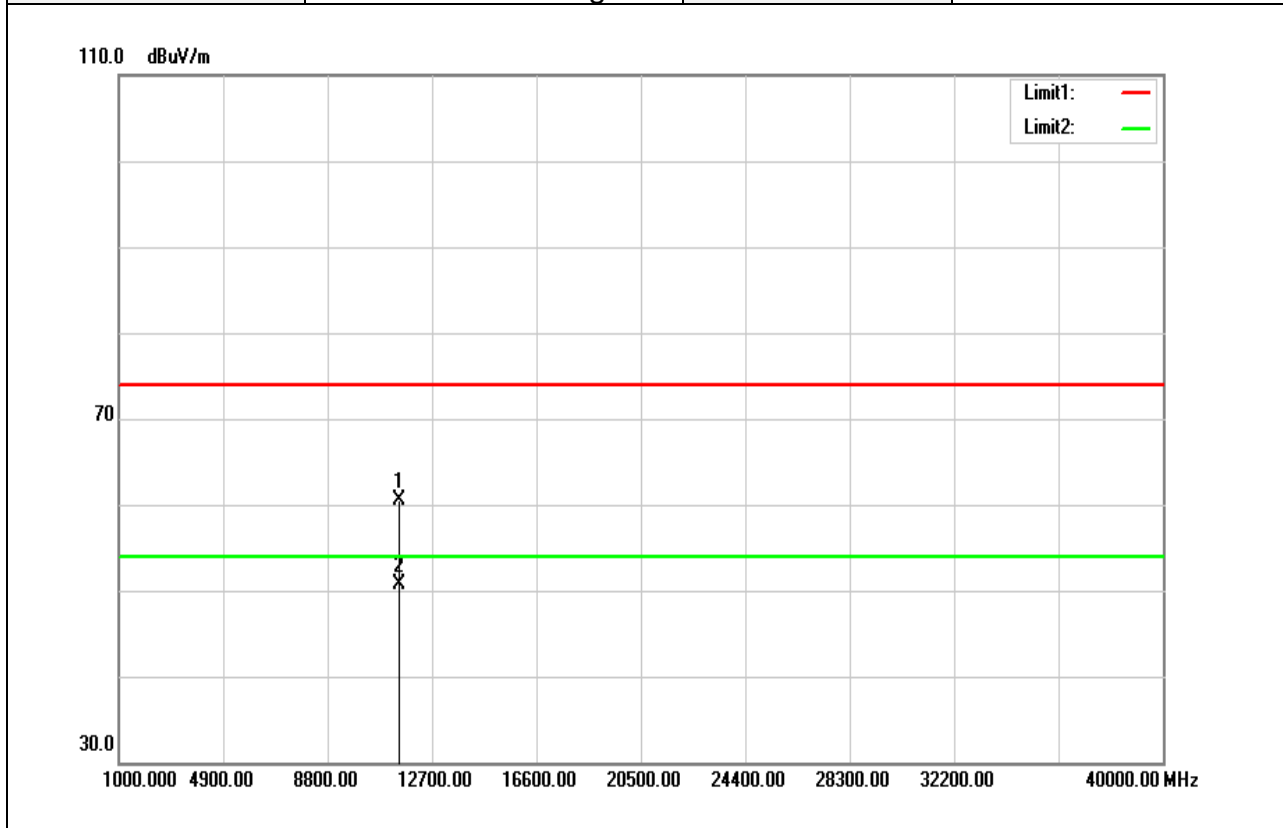

Frequency (MHz)	Reading (dBuV)	Correct Factor (dB/m)	Result (dBuV/m)	Limit (dBuV/m)	Margin (dB)	Remark
11490.000	44.42	16.09	60.51	74.00	-13.49	peak
11490.000	34.54	16.09	50.63	54.00	-3.37	AVG
N/A						

Remark:

1. Measuring frequencies from 1 GHz to the 10th harmonic of highest fundamental frequency.
2. For above 1GHz, the EUT peak value was under average limit, therefore the Average value compliance with the average limit

Report No.: T180627D11-RP4

Test Mode	IEEE 802.11a / 5825 MHz	Temp/Hum	22(°C)/ 34%RH
Test Item	Harmonic	Test Date	July 30, 2018
Polarize	Vertical	Test Engineer	Jerry Chuang
Detector	Peak and Average		

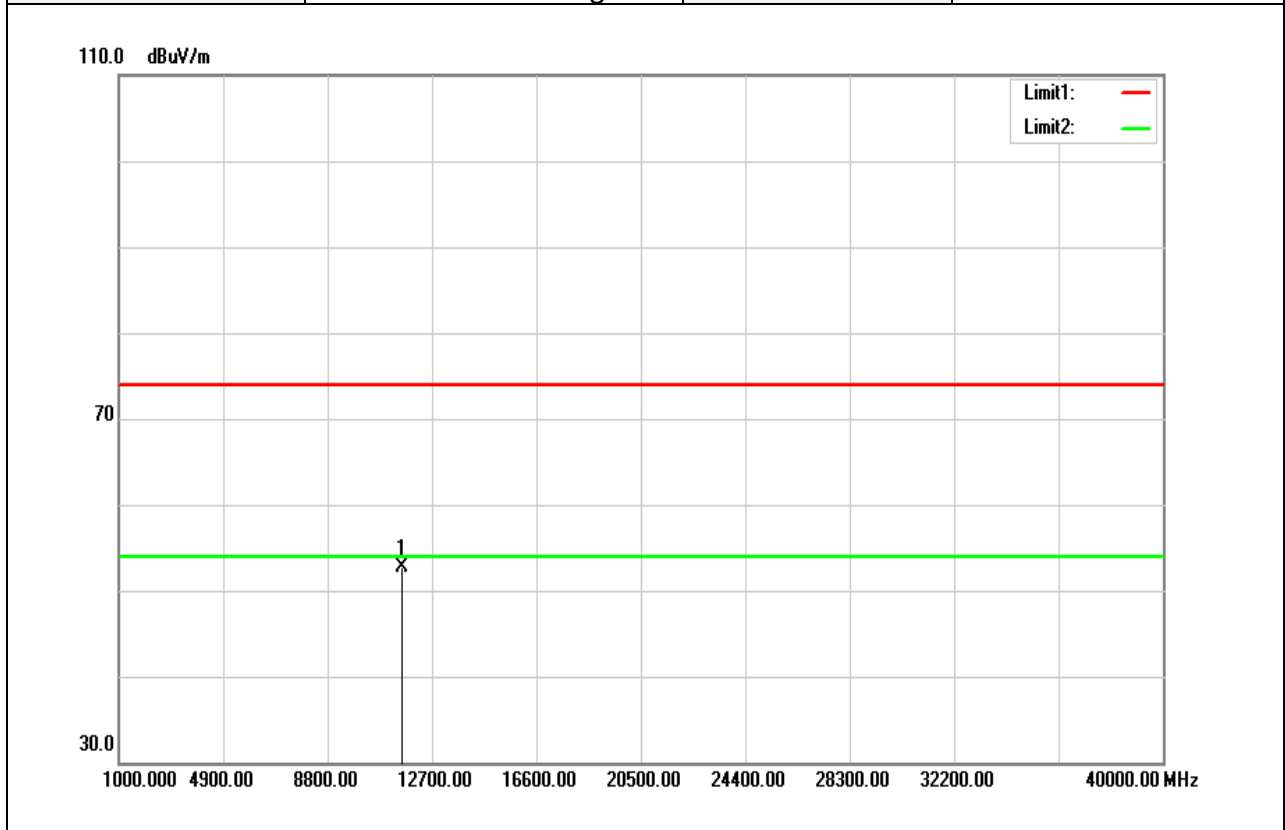

Frequency (MHz)	Reading (dBuV)	Correct Factor (dB/m)	Result (dBuV/m)	Limit (dBuV/m)	Margin (dB)	Remark
11570.000	36.61	16.01	52.62	74.00	-21.38	peak
N/A						

Remark:

1. Measuring frequencies from 1 GHz to the 10th harmonic of highest fundamental frequency.
2. For above 1GHz, the EUT peak value was under average limit, therefore the Average value compliance with the average limit

Report No.: T180627D11-RP4

Test Mode	IEEE 802.11a / 5825 MHz	Temp/Hum	22(°C)/ 34%RH
Test Item	Harmonic	Test Date	July 30, 2018
Polarize	Horizontal	Test Engineer	Jerry Chuang
Detector	Peak and Average		

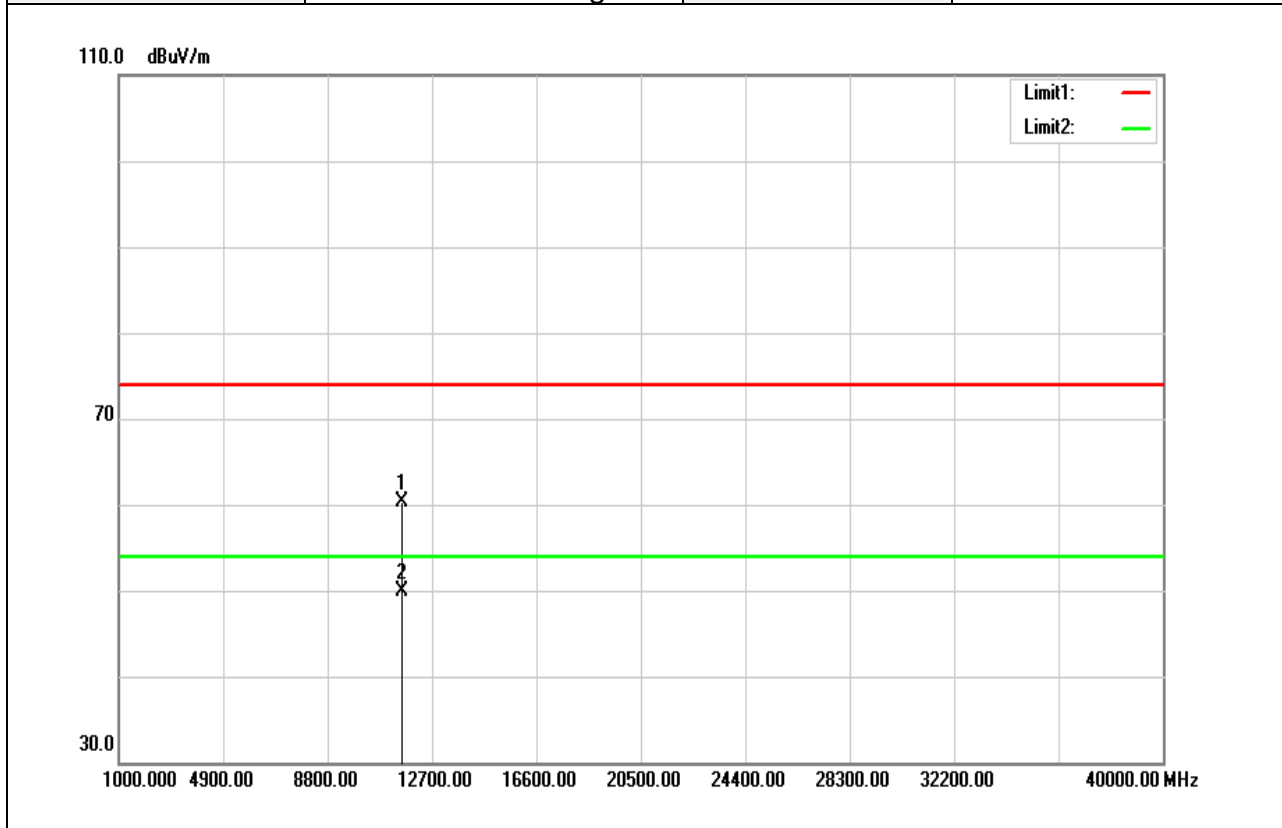

Frequency (MHz)	Reading (dBuV)	Correct Factor (dB/m)	Result (dBuV/m)	Limit (dBuV/m)	Margin (dB)	Remark
11570.000	44.29	16.01	60.30	74.00	-13.70	peak
11570.000	33.84	16.01	49.85	54.00	-4.15	AVG
N/A						

Remark:

1. Measuring frequencies from 1 GHz to the 10th harmonic of highest fundamental frequency.
2. For above 1GHz, the EUT peak value was under average limit, therefore the Average value compliance with the average limit

Report No.: T180627D11-RP4

Test Mode	IEEE 802.11a / 5825 MHz	Temp/Hum	22(°C)/ 34%RH
Test Item	Harmonic	Test Date	July 30, 2018
Polarize	Vertical	Test Engineer	Jerry Chuang
Detector	Peak and Average		

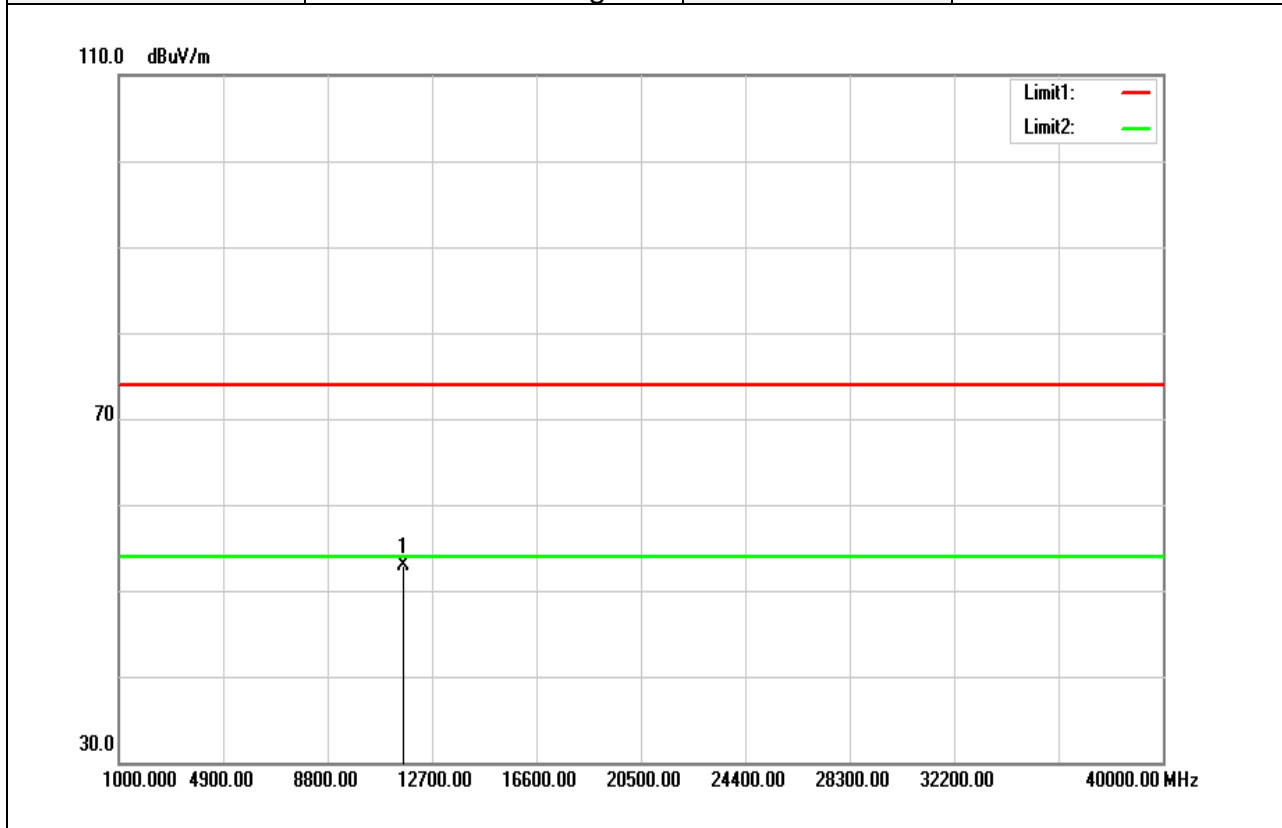

Frequency (MHz)	Reading (dBuV)	Correct Factor (dB/m)	Result (dBuV/m)	Limit (dBuV/m)	Margin (dB)	Remark
11650.000	36.90	15.93	52.83	74.00	-21.17	peak
N/A						

Remark:

1. Measuring frequencies from 1 GHz to the 10th harmonic of highest fundamental frequency.
2. For above 1GHz, the EUT peak value was under average limit, therefore the Average value compliance with the average limit

Report No.: T180627D11-RP4

Test Mode	IEEE 802.11a / 5825 MHz	Temp/Hum	22(°C)/ 34%RH
Test Item	Harmonic	Test Date	July 30, 2018
Polarize	Horizontal	Test Engineer	Jerry Chuang
Detector	Peak and Average		

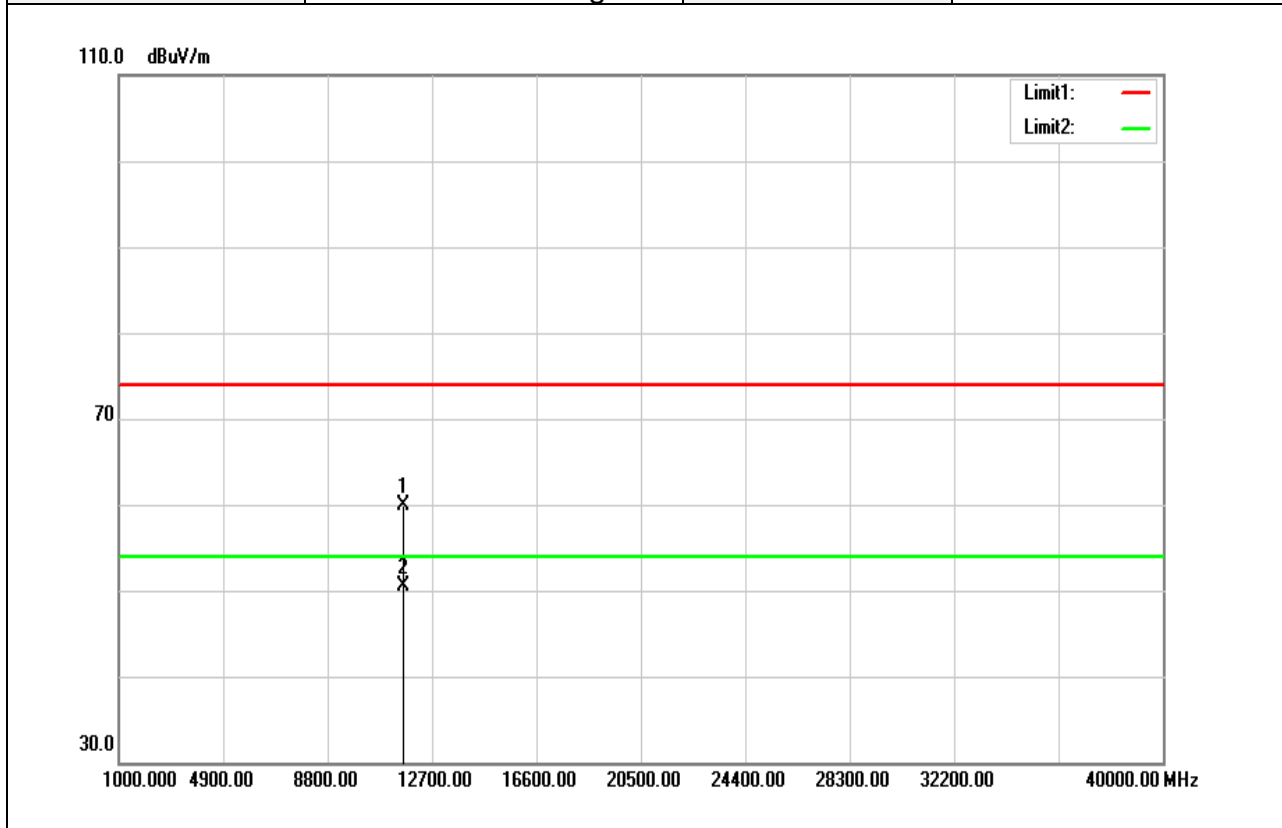

Frequency (MHz)	Reading (dBuV)	Correct Factor (dB/m)	Result (dBuV/m)	Limit (dBuV/m)	Margin (dB)	Remark
11650.000	43.95	15.93	59.88	74.00	-14.12	peak
11650.000	34.61	15.93	50.54	54.00	-3.46	AVG
N/A						

Remark:

- Measuring frequencies from 1 GHz to the 10th harmonic of highest fundamental frequency.
- For above 1GHz, the EUT peak value was under average limit, therefore the Average value compliance with the average limit

Report No.: T180627D11-RP4

Test Mode	IEEE 802.11n HT20 / 5745 MHz	Temp/Hum	22(°C)/ 34%RH
Test Item	Harmonic	Test Date	July 30, 2018
Polarize	Vertical	Test Engineer	Jerry Chuang
Detector	Peak and Average		

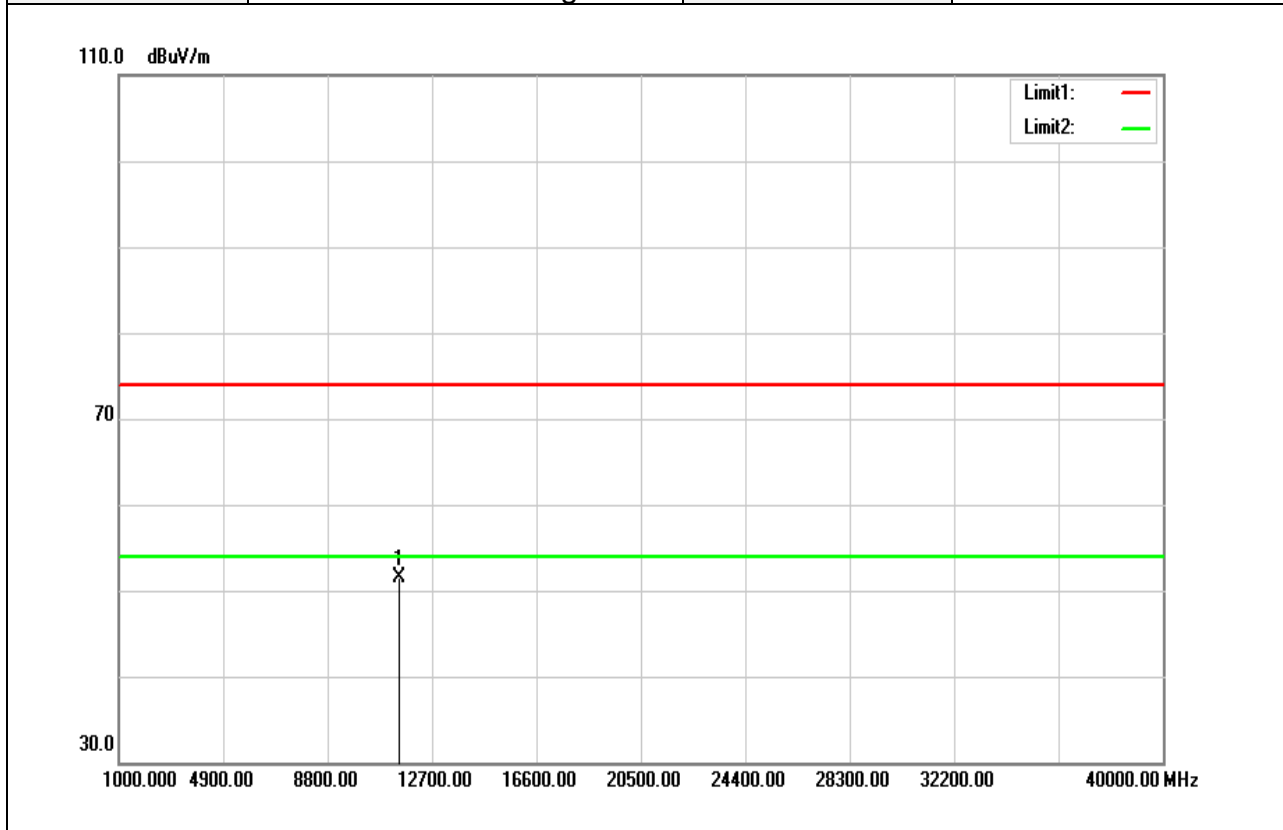

Frequency (MHz)	Reading (dBuV)	Correct Factor (dB/m)	Result (dBuV/m)	Limit (dBuV/m)	Margin (dB)	Remark
11490.000	35.39	16.09	51.48	74.00	-22.52	peak
N/A						

Remark:

1. Measuring frequencies from 1 GHz to the 10th harmonic of highest fundamental frequency.
2. For above 1GHz, the EUT peak value was under average limit, therefore the Average value compliance with the average limit

Report No.: T180627D11-RP4

Test Mode	IEEE 802.11n HT20 / 5745 MHz	Temp/Hum	22(°C)/ 34%RH
Test Item	Harmonic	Test Date	July 30, 2018
Polarize	Horizontal	Test Engineer	Jerry Chuang
Detector	Peak and Average		

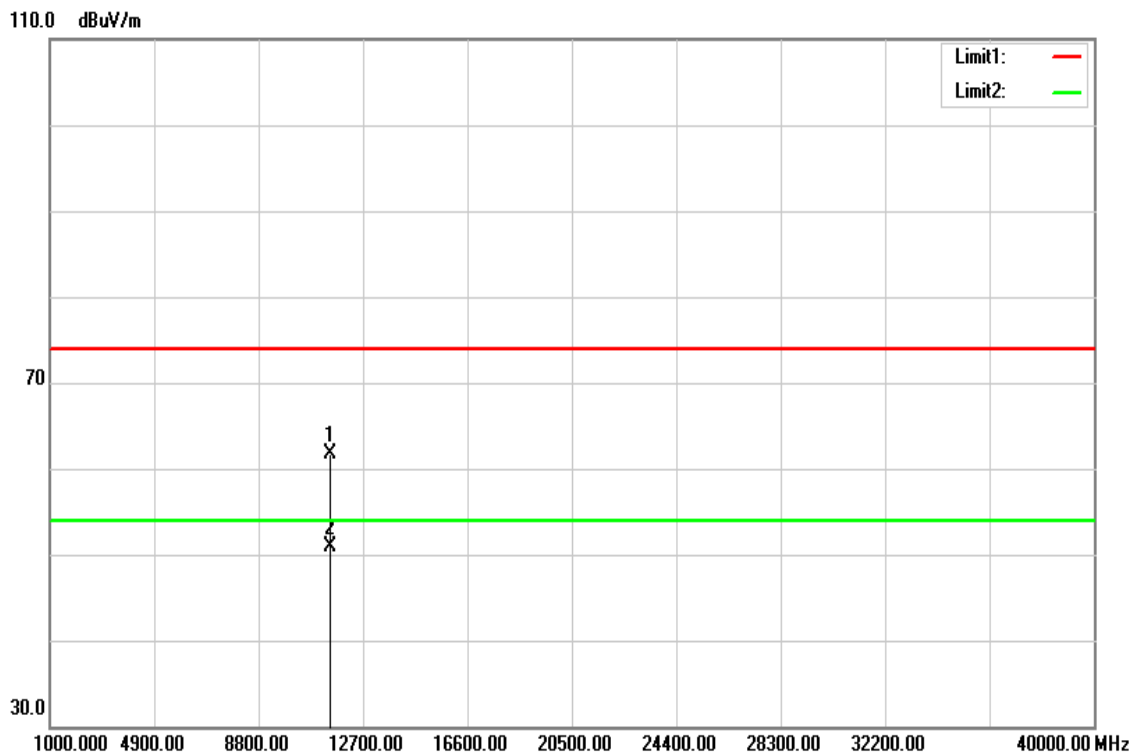

Frequency (MHz)	Reading (dBuV)	Correct Factor (dB/m)	Result (dBuV/m)	Limit (dBuV/m)	Margin (dB)	Remark
11490.000	45.61	16.09	61.70	74.00	-12.30	peak
11490.000	34.73	16.09	50.82	54.00	-3.18	AVG
N/A						

Remark:

1. Measuring frequencies from 1 GHz to the 10th harmonic of highest fundamental frequency.
2. For above 1GHz, the EUT peak value was under average limit, therefore the Average value compliance with the average limit

Report No.: T180627D11-RP4

Test Mode	IEEE 802.11n HT20/ 5785 MHz	Temp/Hum	22(°C)/ 34%RH
Test Item	Harmonic	Test Date	July 30, 2018
Polarize	Vertical	Test Engineer	Jerry Chuang
Detector	Peak and Average		

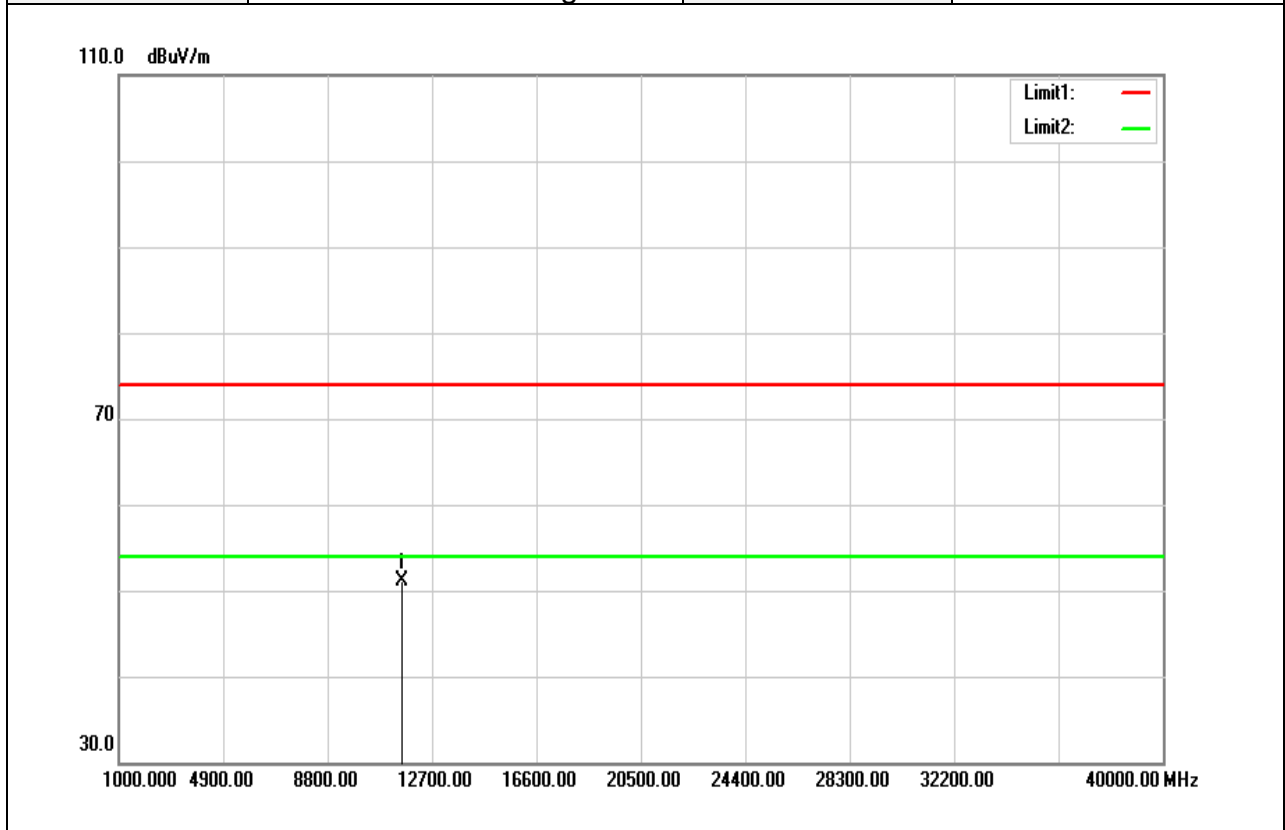

Frequency (MHz)	Reading (dBuV)	Correct Factor (dB/m)	Result (dBuV/m)	Limit (dBuV/m)	Margin (dB)	Remark
11570.000	35.03	16.01	51.04	74.00	-22.96	peak
N/A						

Remark:

1. Measuring frequencies from 1 GHz to the 10th harmonic of highest fundamental frequency.
2. For above 1GHz, the EUT peak value was under average limit, therefore the Average value compliance with the average limit

Report No.: T180627D11-RP4

Test Mode	IEEE 802.11n HT20/ 5785 MHz	Temp/Hum	22(°C)/ 34%RH
Test Item	Harmonic	Test Date	July 30, 2018
Polarize	Horizontal	Test Engineer	Jerry Chuang
Detector	Peak and Average		

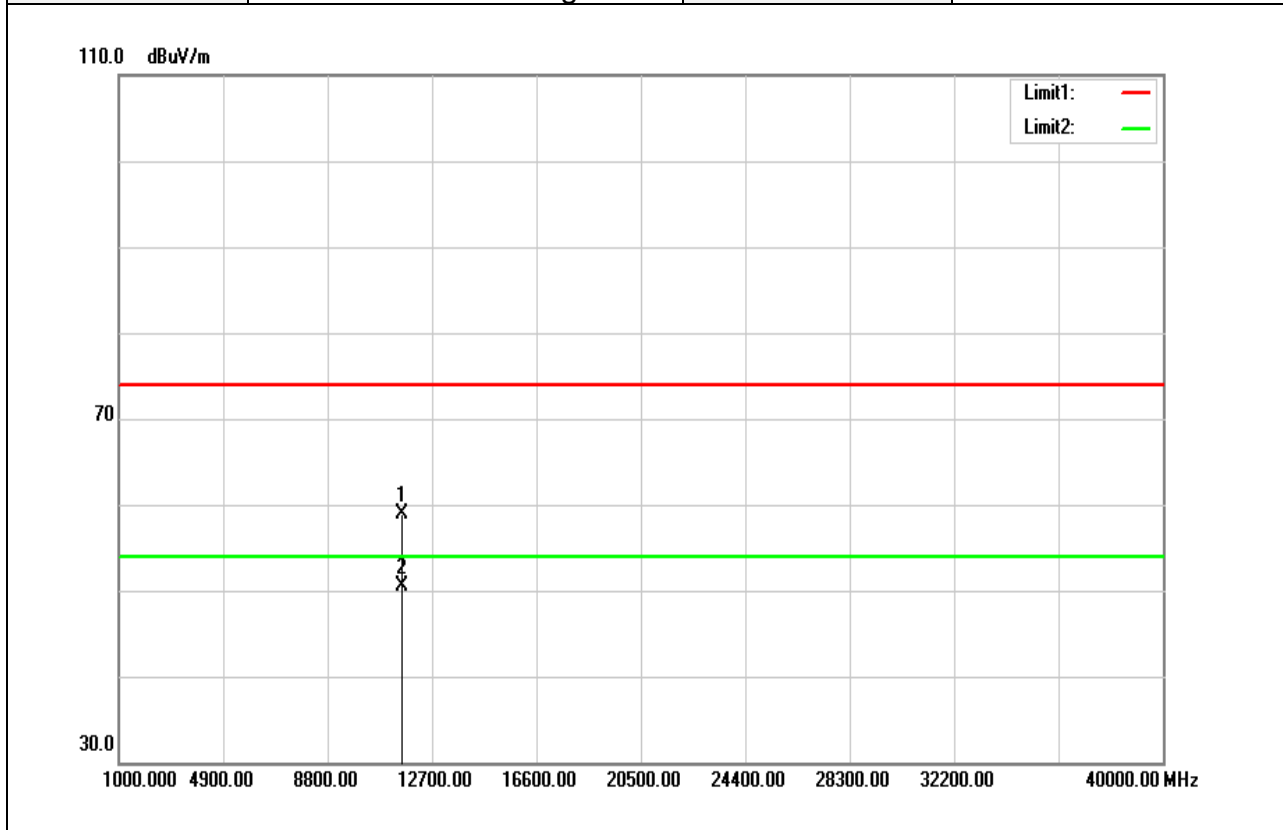

Frequency (MHz)	Reading (dBuV)	Correct Factor (dB/m)	Result (dBuV/m)	Limit (dBuV/m)	Margin (dB)	Remark
11570.000	42.93	16.01	58.94	74.00	-15.06	peak
11570.000	34.55	16.01	50.56	54.00	-3.44	AVG
N/A						

Remark:

1. Measuring frequencies from 1 GHz to the 10th harmonic of highest fundamental frequency.
2. For above 1GHz, the EUT peak value was under average limit, therefore the Average value compliance with the average limit

Report No.: T180627D11-RP4

Test Mode	IEEE 802.11n HT20/ 5825 MHz	Temp/Hum	22(°C)/ 34%RH
Test Item	Harmonic	Test Date	July 30, 2018
Polarize	Vertical	Test Engineer	Jerry Chuang
Detector	Peak and Average		

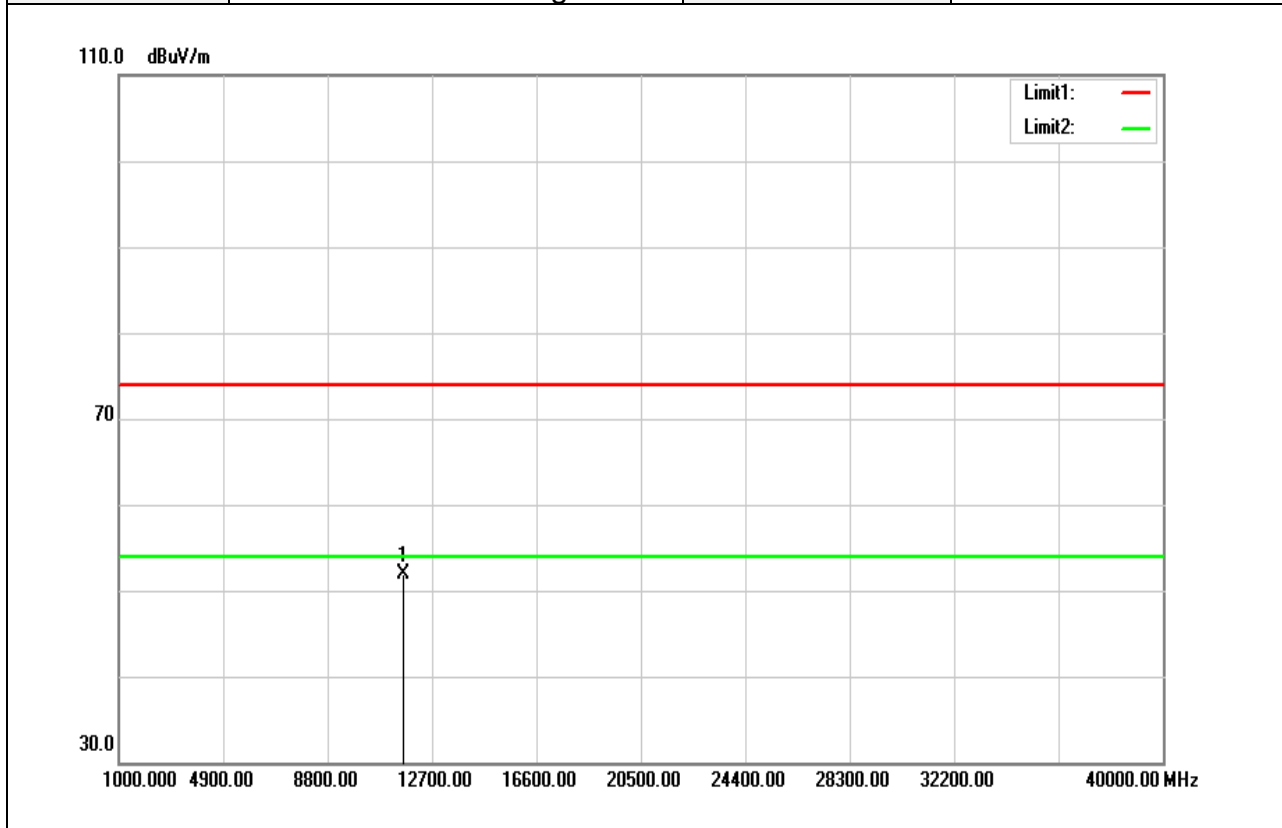

Frequency (MHz)	Reading (dBuV)	Correct Factor (dB/m)	Result (dBuV/m)	Limit (dBuV/m)	Margin (dB)	Remark
11650.000	36.01	15.93	51.94	74.00	-22.06	peak
N/A						

Remark:

1. Measuring frequencies from 1 GHz to the 10th harmonic of highest fundamental frequency.
2. For above 1GHz, the EUT peak value was under average limit, therefore the Average value compliance with the average limit

Test Mode	IEEE 802.11n HT20/ 5825 MHz	Temp/Hum	22(°C)/ 34%RH
Test Item	Harmonic	Test Date	July 30, 2018
Polarize	Horizontal	Test Engineer	Jerry Chuang
Detector	Peak and Average		

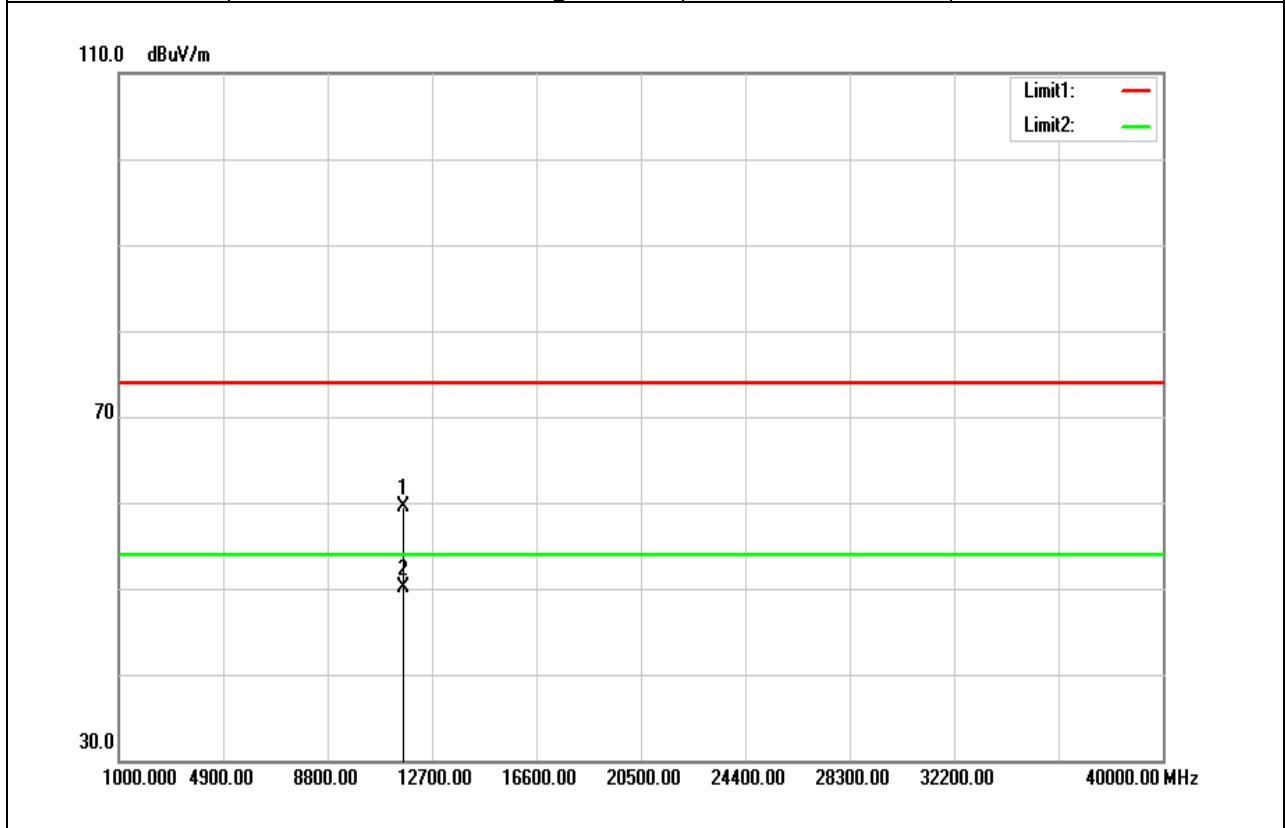

Frequency (MHz)	Reading (dBuV)	Correct Factor (dB/m)	Result (dBuV/m)	Limit (dBuV/m)	Margin (dB)	Remark
11650.000	43.64	15.93	59.57	74.00	-14.43	peak
11650.000	34.21	15.93	50.14	54.00	-3.86	AVG
N/A						

Remark:

1. Measuring frequencies from 1 GHz to the 10th harmonic of highest fundamental frequency.
2. For above 1GHz, the EUT peak value was under average limit, therefore the Average value compliance with the average limit

Report No.: T180627D11-RP4

Test Mode	IEEE 802.11n HT40/ 5755 MHz	Temp/Hum	22(°C)/ 34%RH
Test Item	Harmonic	Test Date	July 30, 2018
Polarize	Vertical	Test Engineer	Jerry Chuang
Detector	Peak and Average		

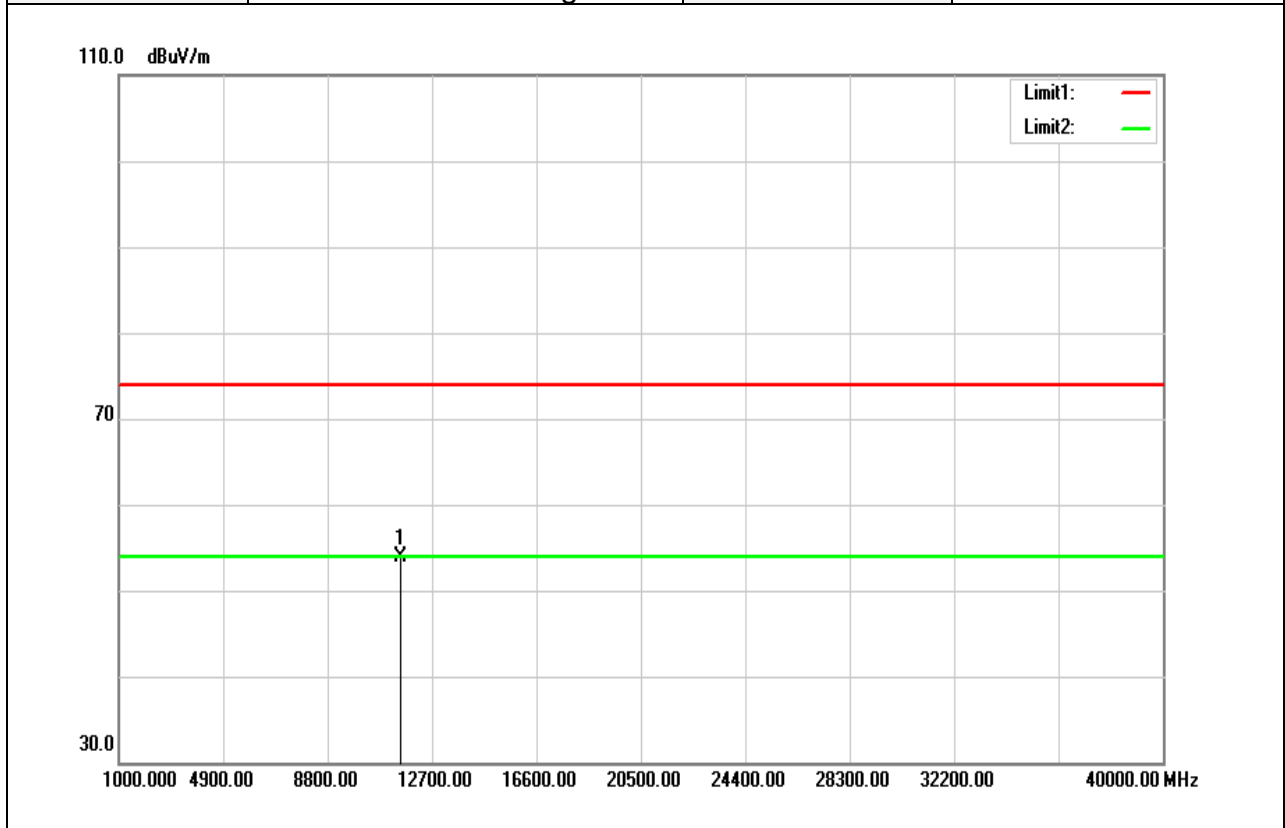

Frequency (MHz)	Reading (dBuV)	Correct Factor (dB/m)	Result (dBuV/m)	Limit (dBuV/m)	Margin (dB)	Remark
11510.000	37.86	16.08	53.94	74.00	-20.06	peak
N/A						

Remark:

1. Measuring frequencies from 1 GHz to the 10th harmonic of highest fundamental frequency.
2. For above 1GHz, the EUT peak value was under average limit, therefore the Average value compliance with the average limit

Test Mode	IEEE 802.11n HT40/ 5755 MHz	Temp/Hum	22(°C)/ 34%RH
Test Item	Harmonic	Test Date	July 30, 2018
Polarize	Horizontal	Test Engineer	Jerry Chuang
Detector	Peak and Average		

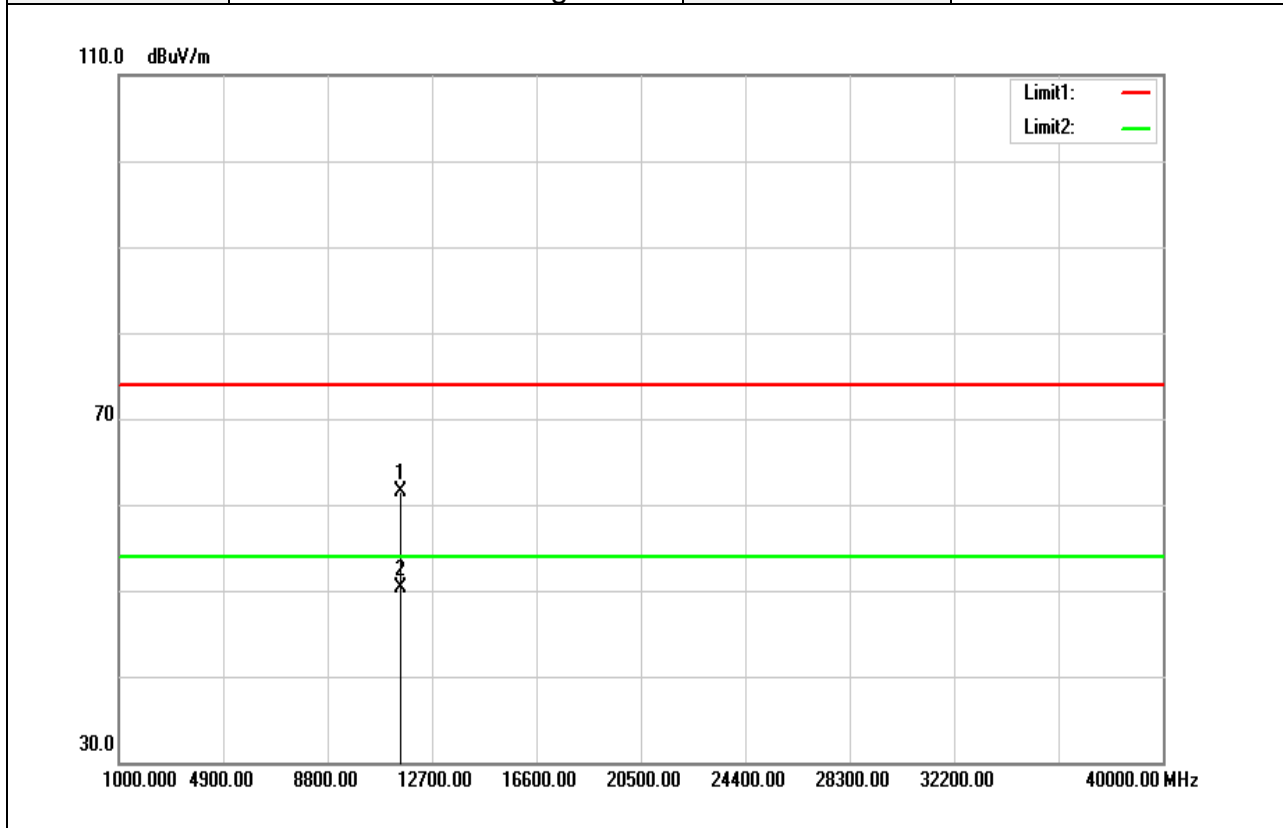

Frequency (MHz)	Reading (dBuV)	Correct Factor (dB/m)	Result (dBuV/m)	Limit (dBuV/m)	Margin (dB)	Remark
11510.000	45.46	16.08	61.54	74.00	-12.46	peak
11510.000	34.31	16.08	50.39	54.00	-3.61	AVG
N/A						

Remark:

- Measuring frequencies from 1 GHz to the 10th harmonic of highest fundamental frequency.
- For above 1GHz, the EUT peak value was under average limit, therefore the Average value compliance with the average limit

Test Mode	IEEE 802.11n HT40/ 5795 MHz	Temp/Hum	22(°C)/ 34%RH
Test Item	Harmonic	Test Date	July 30, 2018
Polarize	Vertical	Test Engineer	Jerry Chuang
Detector	Peak and Average		

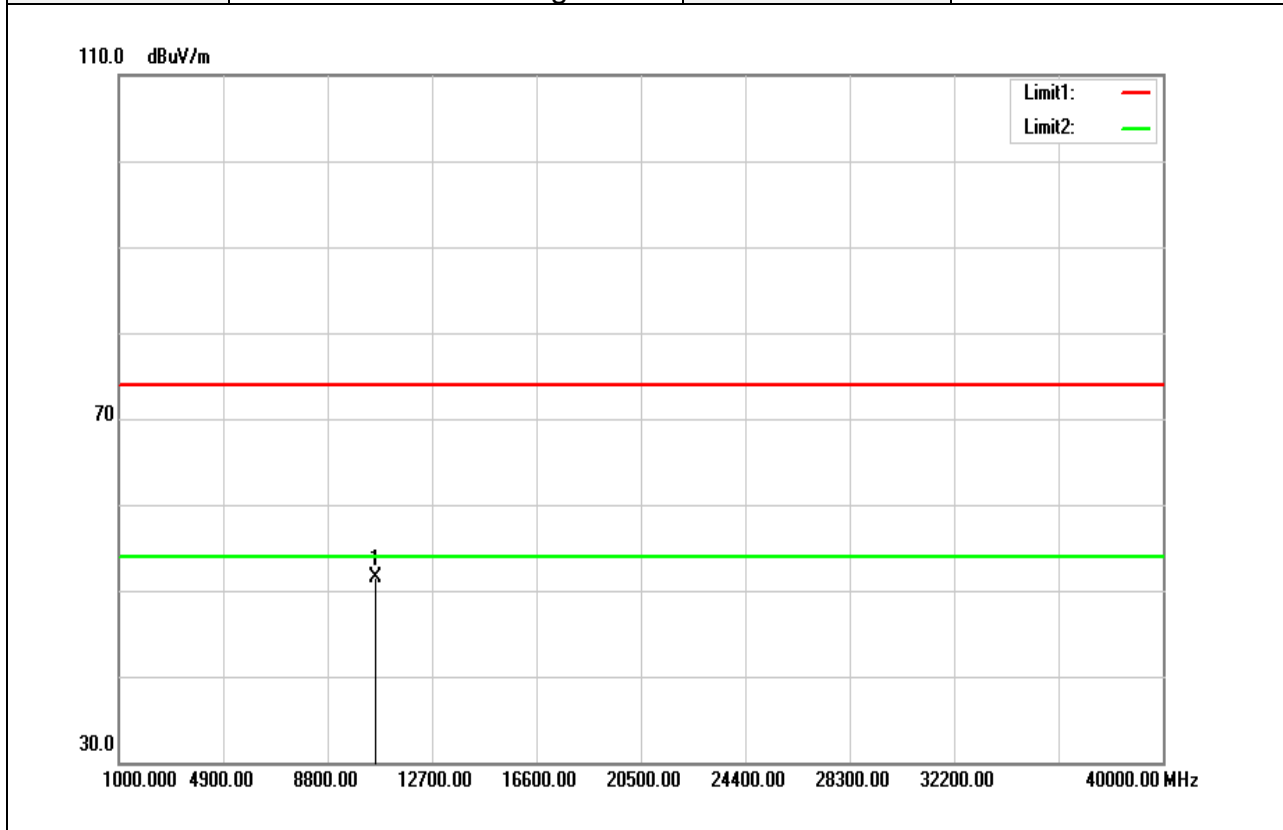

Frequency (MHz)	Reading (dBuV)	Correct Factor (dB/m)	Result (dBuV/m)	Limit (dBuV/m)	Margin (dB)	Remark
10590.000	36.41	15.12	51.53	74.00	-22.47	peak
N/A						

Remark:

1. Measuring frequencies from 1 GHz to the 10th harmonic of highest fundamental frequency.
2. For above 1GHz, the EUT peak value was under average limit, therefore the Average value compliance with the average limit

Report No.: T180627D11-RP4

Test Mode	IEEE 802.11n HT40/ 5795 MHz	Temp/Hum	22(°C)/ 34%RH
Test Item	Harmonic	Test Date	July 30, 2018
Polarize	Horizontal	Test Engineer	Jerry Chuang
Detector	Peak and Average		

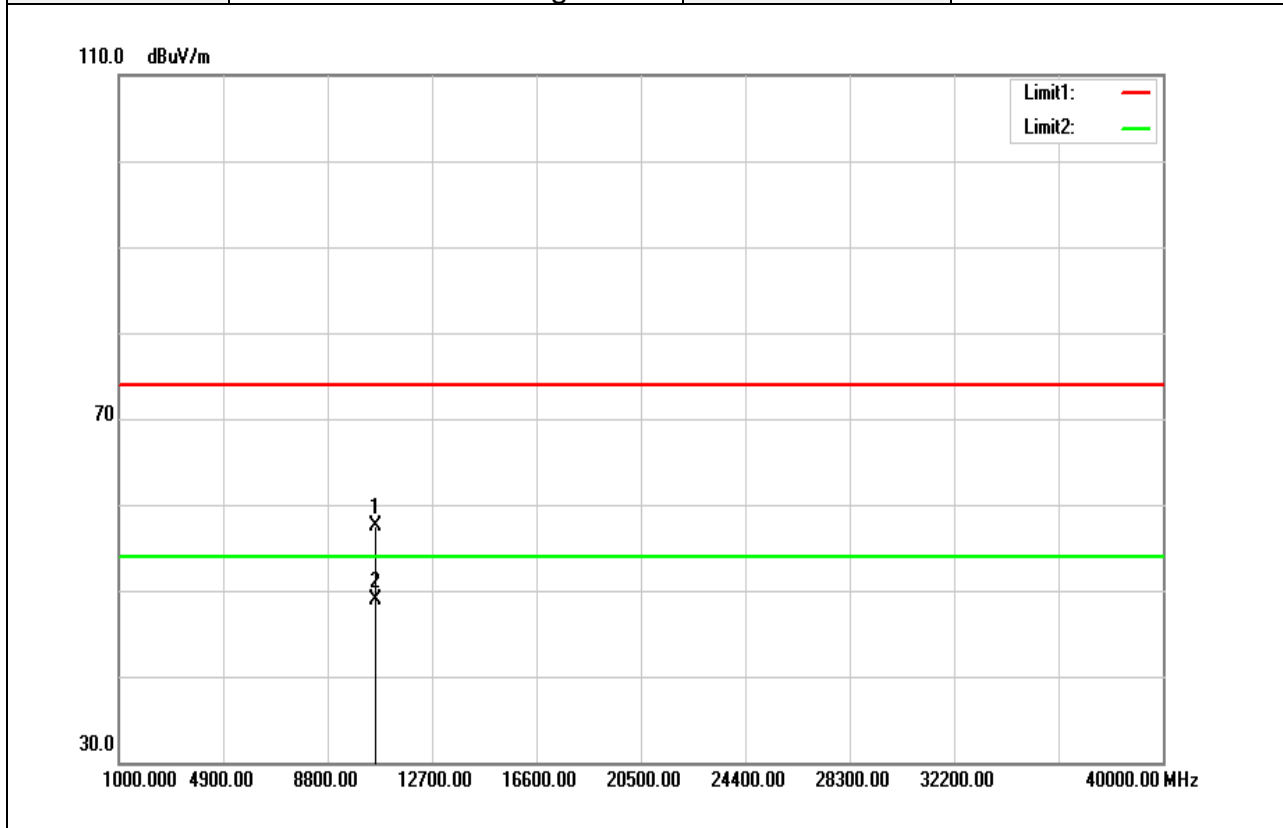

Frequency (MHz)	Reading (dBuV)	Correct Factor (dB/m)	Result (dBuV/m)	Limit (dBuV/m)	Margin (dB)	Remark
10590.000	42.37	15.12	57.49	74.00	-16.51	peak
10590.000	33.86	15.12	48.98	54.00	-5.02	AVG
N/A						

Remark:

- Measuring frequencies from 1 GHz to the 10th harmonic of highest fundamental frequency.
- For above 1GHz, the EUT peak value was under average limit, therefore the Average value compliance with the average limit

Report No.: T180627D11-RP4

Test Mode	IEEE 802.11ac VHT80/ 5775 MHz	Temp/Hum	22(°C)/ 34%RH
Test Item	Harmonic	Test Date	July 30, 2018
Polarize	Vertical	Test Engineer	Jerry Chuang
Detector	Peak and Average		

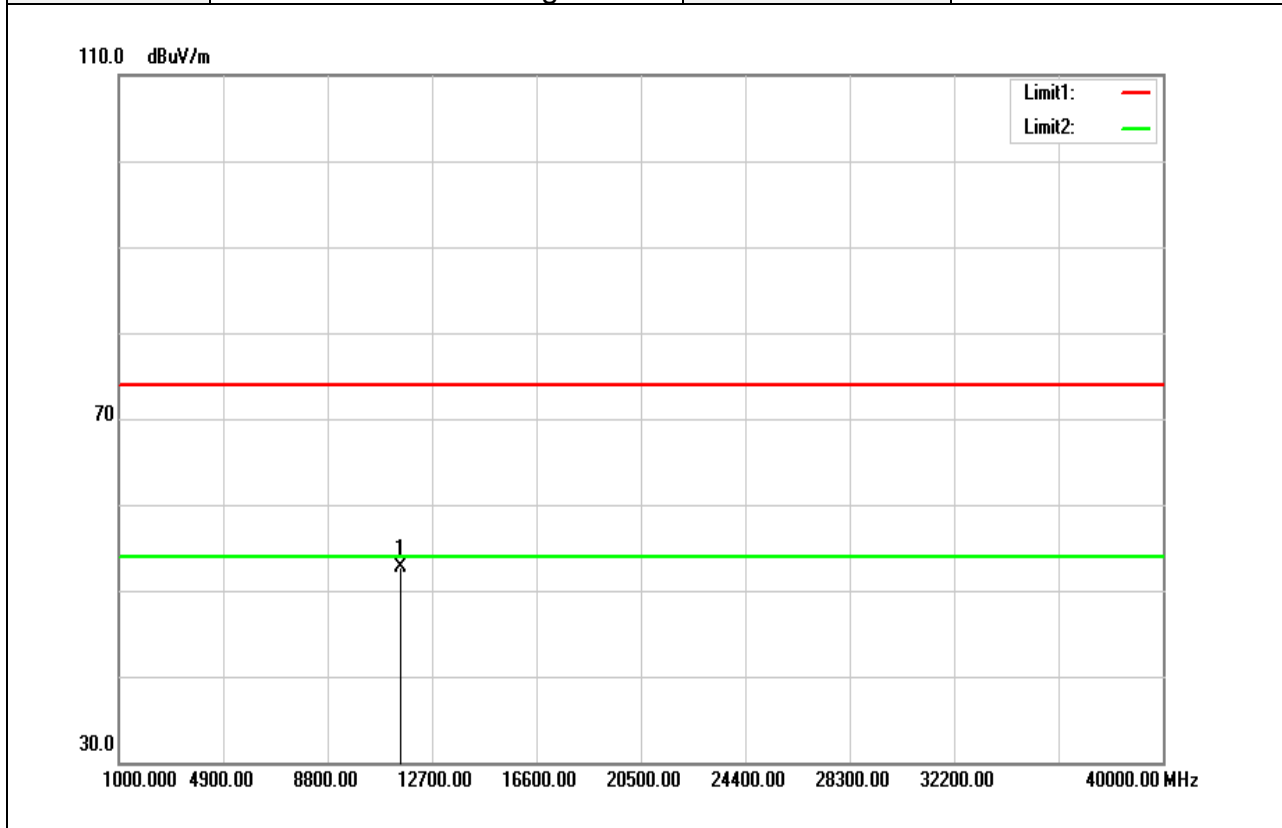

Frequency (MHz)	Reading (dBuV)	Correct Factor (dB/m)	Result (dBuV/m)	Limit (dBuV/m)	Margin (dB)	Remark
11530.000	36.56	16.07	52.63	74.00	-21.37	peak
N/A						

Remark:

1. Measuring frequencies from 1 GHz to the 10th harmonic of highest fundamental frequency.
2. For above 1GHz, the EUT peak value was under average limit, therefore the Average value compliance with the average limit

Test Mode	IEEE 802.11ac VHT80/ 5775 MHz	Temp/Hum	22(°C)/ 34%RH
Test Item	Harmonic	Test Date	July 30, 2018
Polarize	Horizontal	Test Engineer	Jerry Chuang
Detector	Peak and Average		

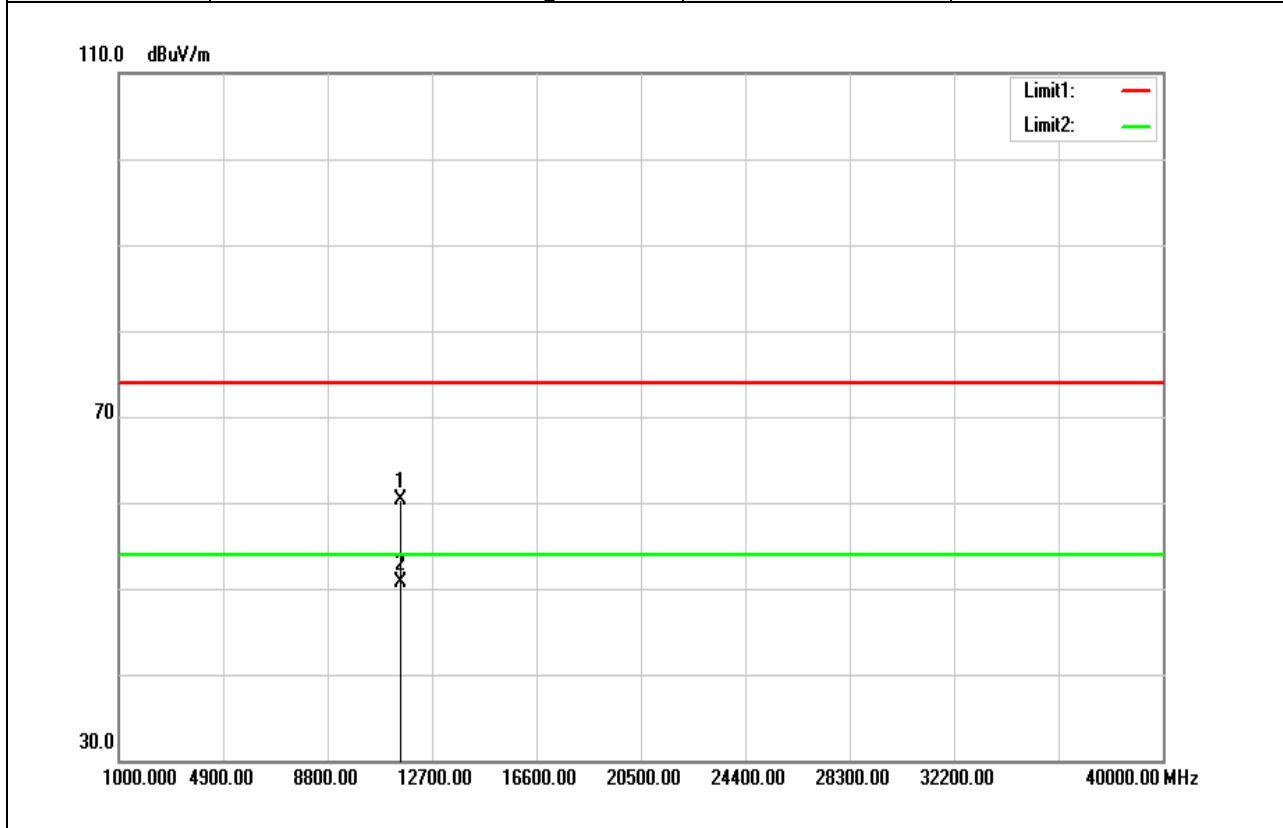

Frequency (MHz)	Reading (dBuV)	Correct Factor (dB/m)	Result (dBuV/m)	Limit (dBuV/m)	Margin (dB)	Remark
11520.000	44.20	16.06	60.26	74.00	-13.74	peak
11520.000	34.66	16.06	50.72	54.00	-3.28	AVG
N/A						

Remark:

- Measuring frequencies from 1 GHz to the 10th harmonic of highest fundamental frequency.
- For above 1GHz, the EUT peak value was under average limit, therefore the Average value compliance with the average limit

For Dipole Antenna

Above 1G Test Data for UNII-1

Test Mode	IEEE 802.11a / 5180MHZ	Temp/Hum	22(°C)/ 34%RH
Test Item	Harmonic	Test Date	July 30, 2018
Polarize	Vertical	Test Engineer	Jerry Chuang
Detector	Peak and Average		

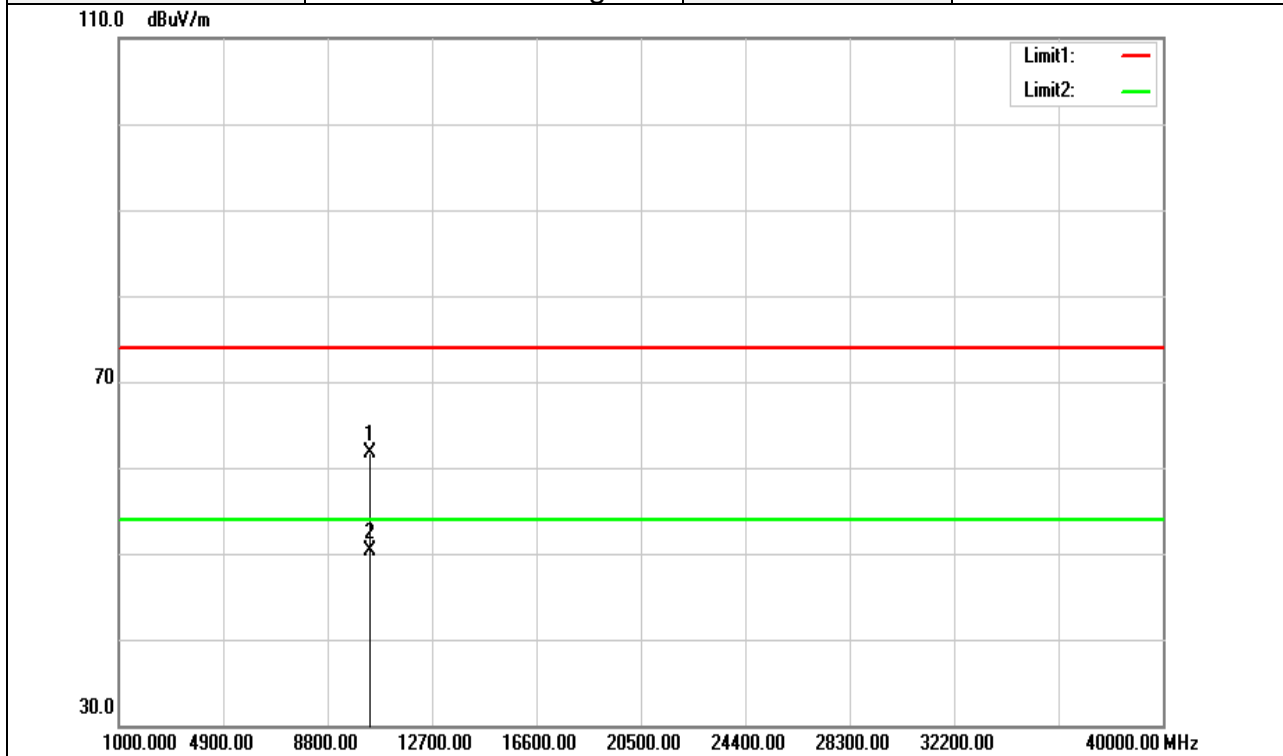

Frequency (MHz)	Reading (dBuV)	Correct Factor (dB/m)	Result (dBuV/m)	Limit (dBuV/m)	Margin (dB)	Remark
10360.000	47.24	14.45	61.69	74.00	-12.31	peak
10360.000	35.87	14.45	50.32	54.00	-3.68	AVG
N/A						

Remark:

1. Measuring frequencies from 1 GHz to the 10th harmonic of highest fundamental frequency.
2. For above 1GHz, the EUT peak value was under average limit, therefore the Average value compliance with the average limit

Report No.: T180627D11-RP4

Test Mode	IEEE 802.11a / 5180MHZ	Temp/Hum	22(°C)/ 34%RH
Test Item	Harmonic	Test Date	July 30, 2018
Polarize	Horizontal	Test Engineer	Jerry Chuang
Detector	Peak and Average		

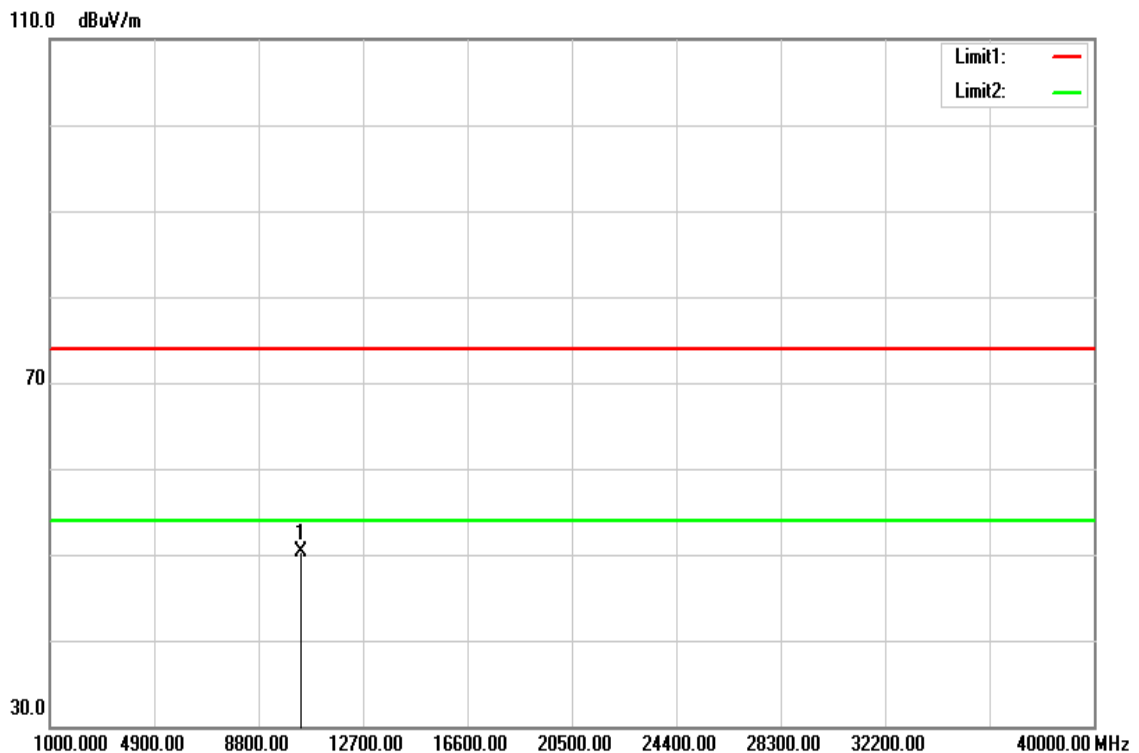

Frequency (MHz)	Reading (dBuV)	Correct Factor (dB/m)	Result (dBuV/m)	Limit (dBuV/m)	Margin (dB)	Remark
10360.000	35.81	14.45	50.26	74.00	-23.74	peak
N/A						

Remark:

1. Measuring frequencies from 1 GHz to the 10th harmonic of highest fundamental frequency.
2. For above 1GHz, the EUT peak value was under average limit, therefore the Average value compliance with the average limit

Report No.: T180627D11-RP4

Test Mode	IEEE 802.11a / 5220 MHZ	Temp/Hum	22(°C)/ 34%RH
Test Item	Horizontal	Test Date	July 30, 2018
Polarize	Vertical	Test Engineer	Jerry Chuang
Detector	Peak and Average		

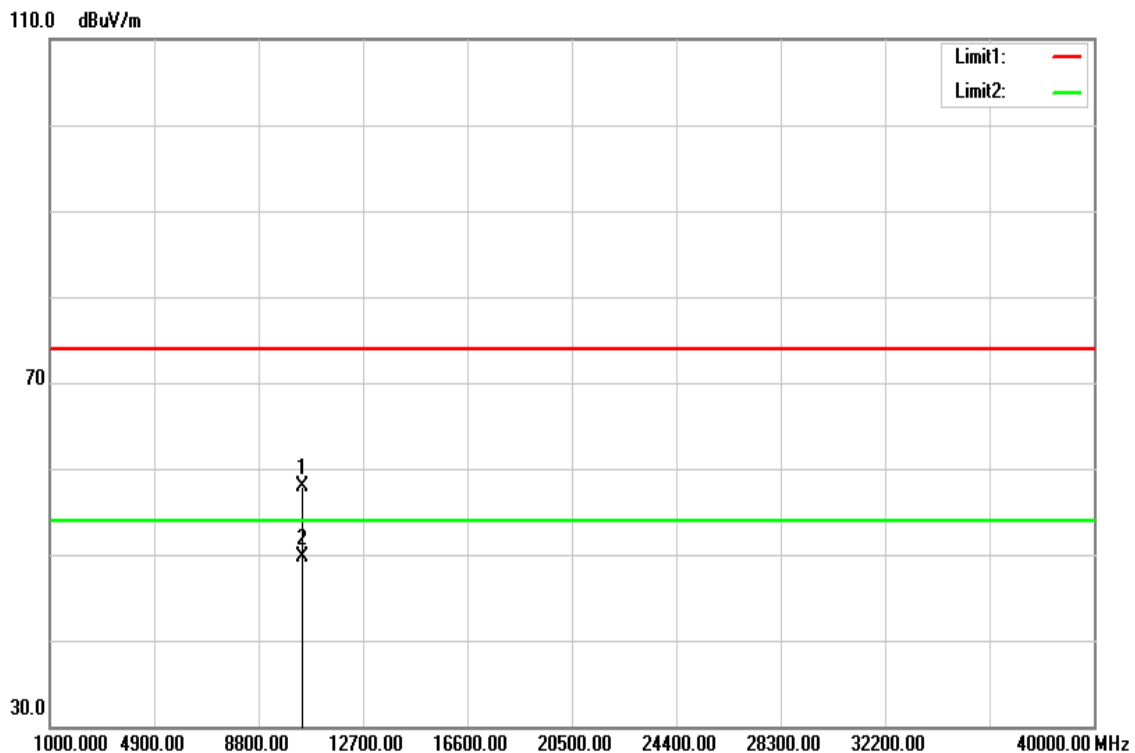

Frequency (MHz)	Reading (dBuV)	Correct Factor (dB/m)	Result (dBuV/m)	Limit (dBuV/m)	Margin (dB)	Remark
10440.000	43.29	14.71	58.00	74.00	-16.00	peak
10440.000	34.97	14.71	49.68	54.00	-4.32	AVG
N/A						

Remark:

1. Measuring frequencies from 1 GHz to the 10th harmonic of highest fundamental frequency.
2. For above 1GHz, the EUT peak value was under average limit, therefore the Average value compliance with the average limit

Report No.: T180627D11-RP4

Test Mode	IEEE 802.11a / 5220 MHz	Temp/Hum	22(°C)/ 34%RH
Test Item	Harmonic	Test Date	July 30, 2018
Polarize	Horizontal	Test Engineer	Jerry Chuang
Detector	Peak and Average		

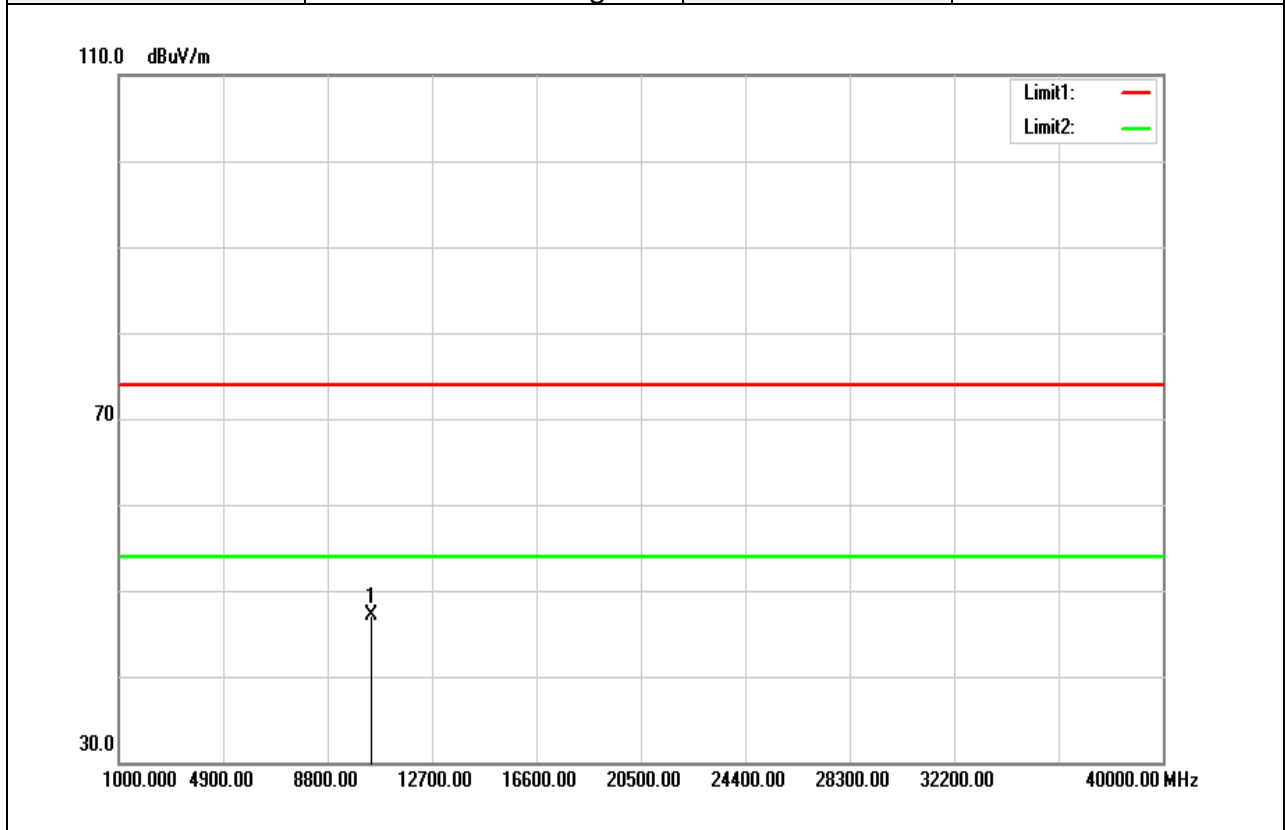

Frequency (MHz)	Reading (dBuV)	Correct Factor (dB/m)	Result (dBuV/m)	Limit (dBuV/m)	Margin (dB)	Remark
10440.000	32.32	14.71	47.03	74.00	-26.97	peak
N/A						

Remark:

1. Measuring frequencies from 1 GHz to the 10th harmonic of highest fundamental frequency.
2. For above 1GHz, the EUT peak value was under average limit, therefore the Average value compliance with the average limit

Report No.: T180627D11-RP4

Test Mode	IEEE 802.11a / 5240MHZ	Temp/Hum	22(°C)/ 34%RH
Test Item	Harmonic	Test Date	July 30, 2018
Polarize	Vertical	Test Engineer	Jerry Chuang
Detector	Peak and Average		

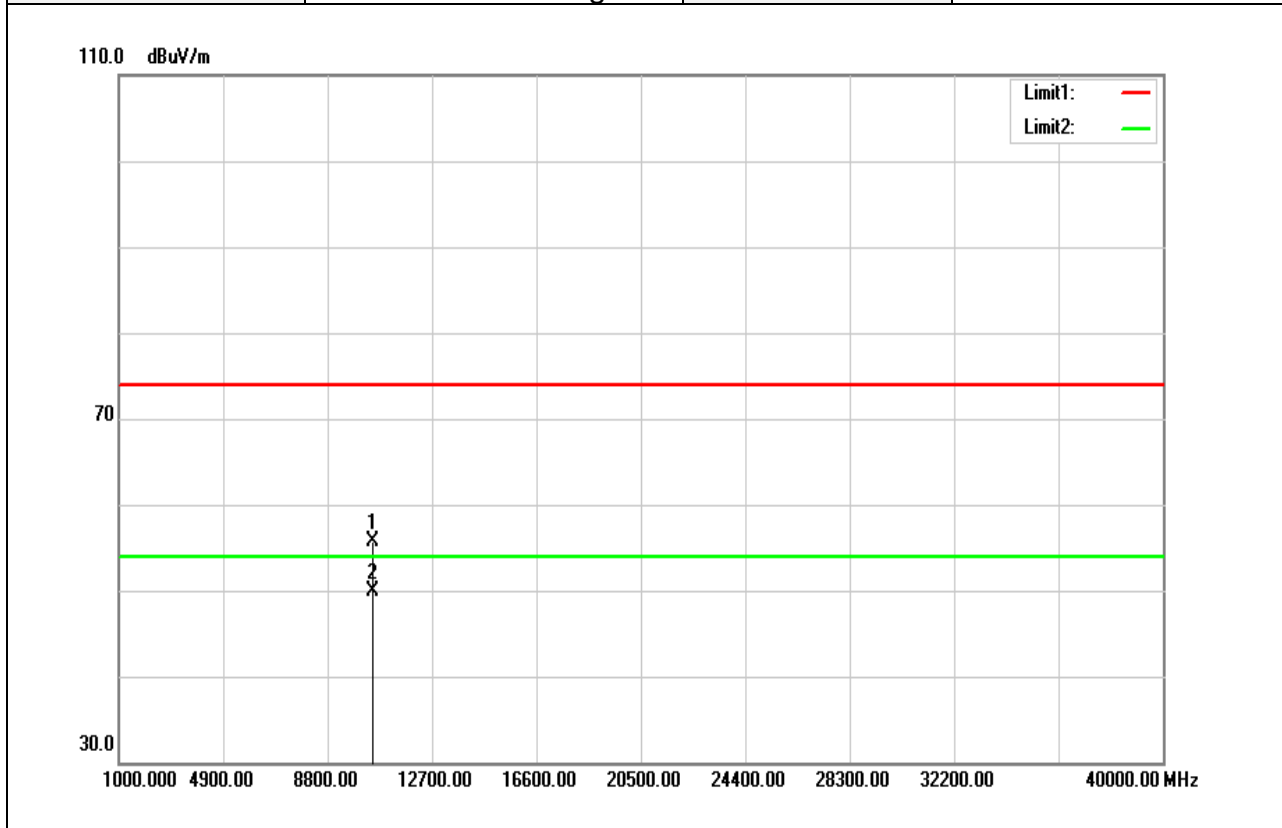

Frequency (MHz)	Reading (dBuV)	Correct Factor (dB/m)	Result (dBuV/m)	Limit (dBuV/m)	Margin (dB)	Remark
10480.000	40.92	14.84	55.76	74.00	-18.24	peak
10480.000	35.08	14.84	49.92	54.00	-4.08	AVG
N/A						

Remark:

1. Measuring frequencies from 1 GHz to the 10th harmonic of highest fundamental frequency.
2. For above 1GHz, the EUT peak value was under average limit, therefore the Average value compliance with the average limit

Report No.: T180627D11-RP4

Test Mode	IEEE 802.11a / 5240MHZ	Temp/Hum	22(°C)/ 34%RH
Test Item	Harmonic	Test Date	July 30, 2018
Polarize	Horizontal	Test Engineer	Jerry Chuang
Detector	Peak and Average		

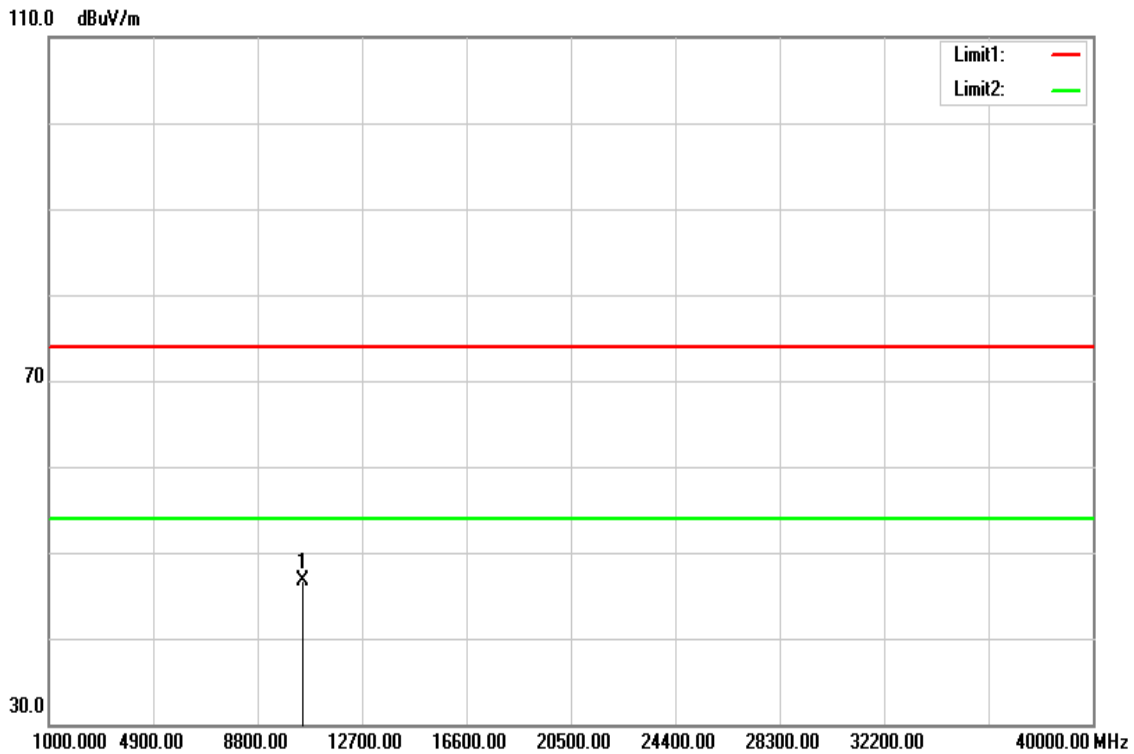

Frequency (MHz)	Reading (dBuV)	Correct Factor (dB/m)	Result (dBuV/m)	Limit (dBuV/m)	Margin (dB)	Remark
10480.000	31.82	14.84	46.66	74.00	-27.34	peak
N/A						

Remark:

1. Measuring frequencies from 1 GHz to the 10th harmonic of highest fundamental frequency.
2. For above 1GHz, the EUT peak value was under average limit, therefore the Average value compliance with the average limit

Report No.: T180627D11-RP4

Test Mode	IEEE 802.11n HT20 / 5180MHZ	Temp/Hum	22(°C)/ 34%RH
Test Item	Harmonic	Test Date	July 30, 2018
Polarize	Vertical	Test Engineer	Jerry Chuang
Detector	Peak and Average		

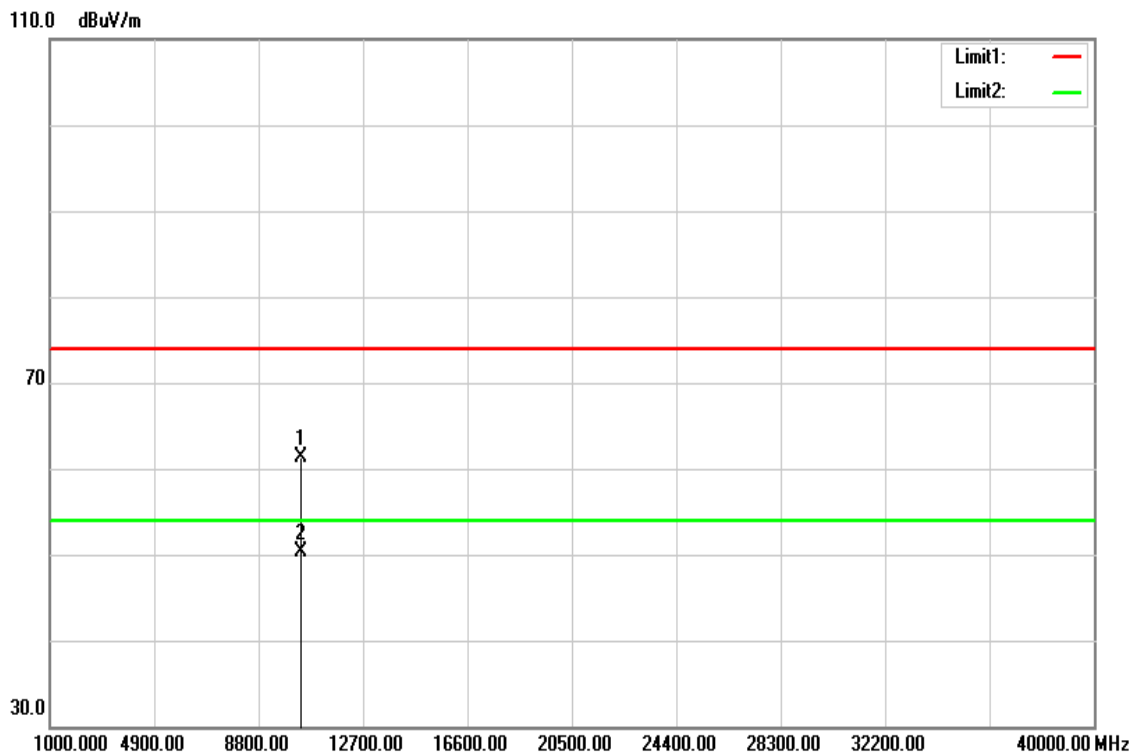

Frequency (MHz)	Reading (dBuV)	Correct Factor (dB/m)	Result (dBuV/m)	Limit (dBuV/m)	Margin (dB)	Remark
10360.000	46.93	14.45	61.38	74.00	-12.62	peak
10360.000	35.77	14.45	50.22	54.00	-3.78	AVG
N/A						

Remark:

1. Measuring frequencies from 1 GHz to the 10th harmonic of highest fundamental frequency.
2. For above 1GHz, the EUT peak value was under average limit, therefore the Average value compliance with the average limit

Report No.: T180627D11-RP4

Test Mode	IEEE 802.11n HT20/ 5180MHZ	Temp/Hum	22(°C)/ 34%RH
Test Item	Harmonic	Test Date	July 30, 2018
Polarize	Horizontal	Test Engineer	Jerry Chuang
Detector	Peak and Average		

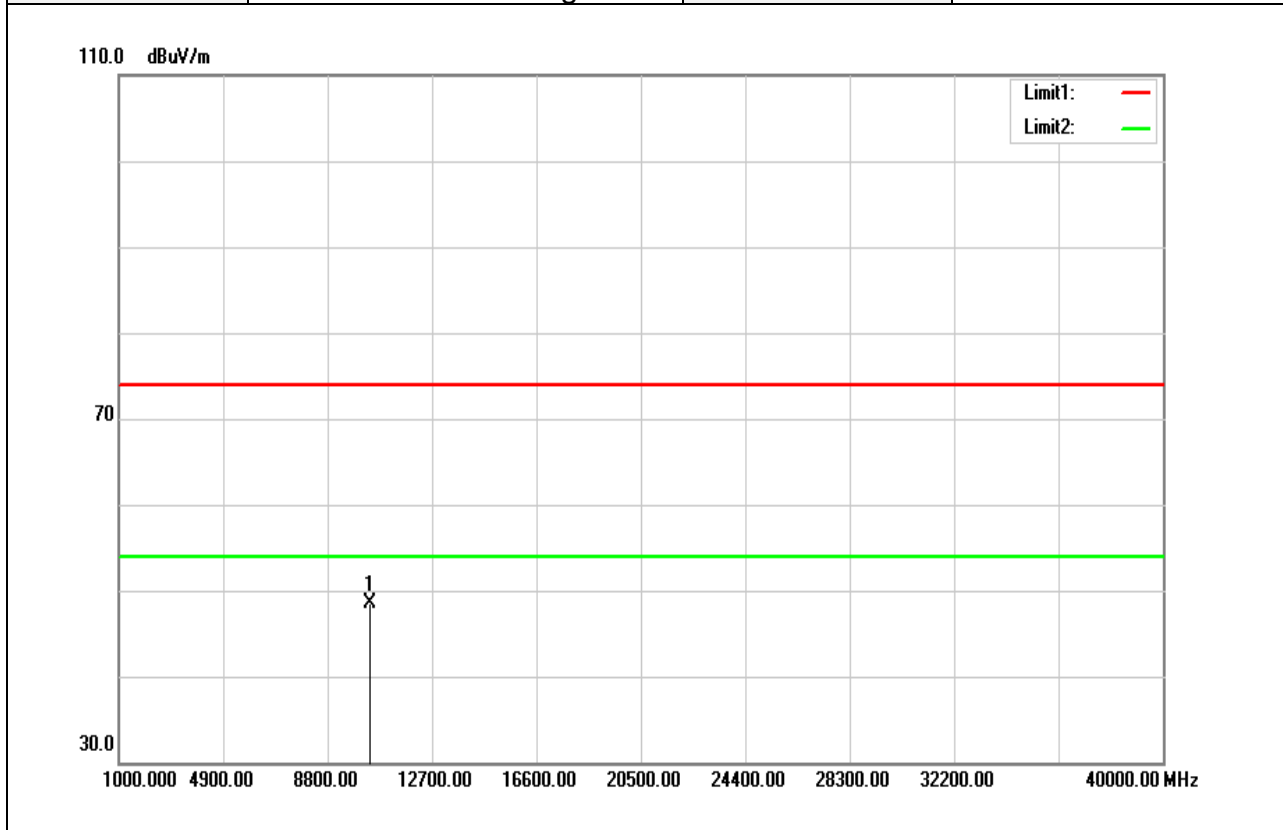

Frequency (MHz)	Reading (dBuV)	Correct Factor (dB/m)	Result (dBuV/m)	Limit (dBuV/m)	Margin (dB)	Remark
10360.000	33.97	14.45	48.42	74.00	-25.58	peak
N/A						

Remark:

1. Measuring frequencies from 1 GHz to the 10th harmonic of highest fundamental frequency.
2. For above 1GHz, the EUT peak value was under average limit, therefore the Average value compliance with the average limit

Test Mode	IEEE 802.11n HT20 / 5220MHZ	Temp/Hum	22(°C)/ 34%RH
Test Item	Harmonic	Test Date	July 30, 2018
Polarize	Vertical	Test Engineer	Jerry Chuang
Detector	Peak and Average		

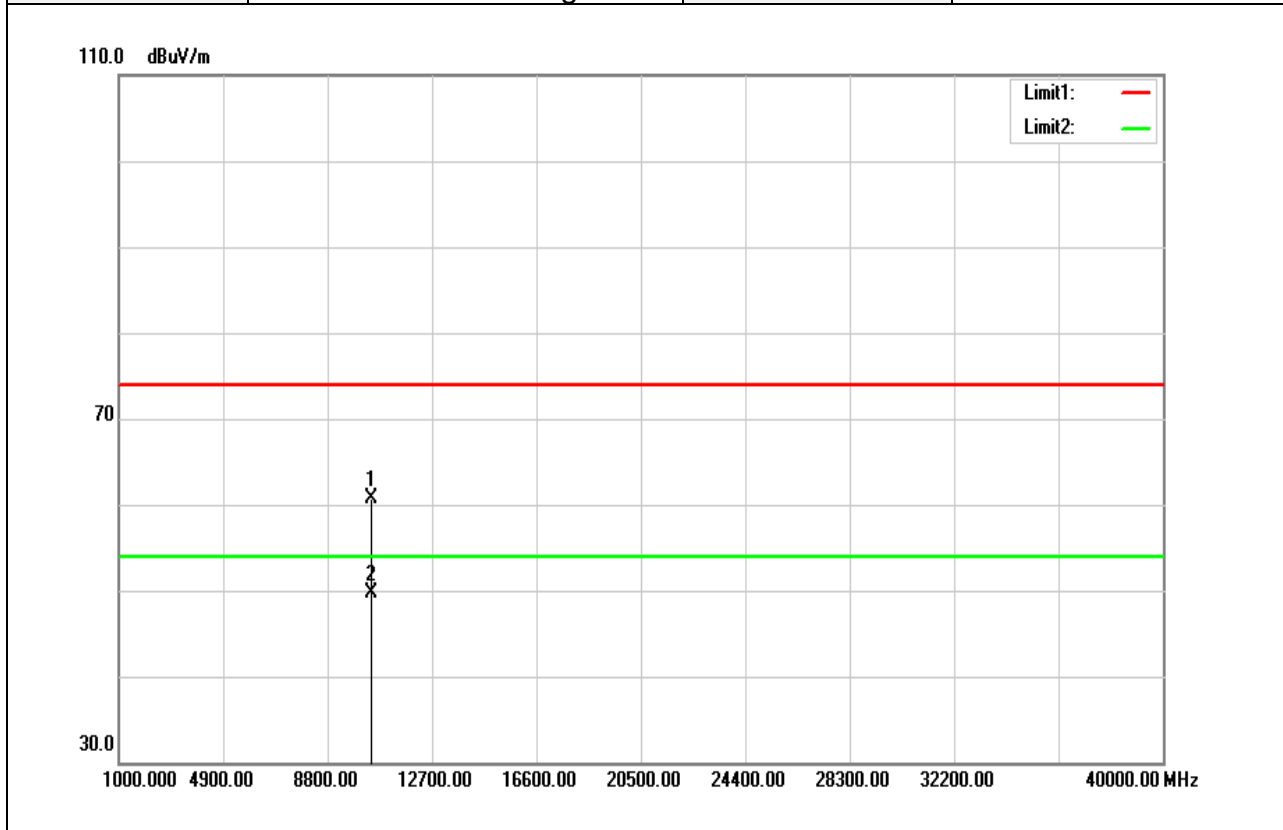

Frequency (MHz)	Reading (dBuV)	Correct Factor (dB/m)	Result (dBuV/m)	Limit (dBuV/m)	Margin (dB)	Remark
10440.000	46.05	14.71	60.76	74.00	-13.24	peak
10440.000	34.98	14.71	49.69	54.00	-4.31	AVG
N/A						

Remark:

1. Measuring frequencies from 1 GHz to the 10th harmonic of highest fundamental frequency.
2. For above 1GHz, the EUT peak value was under average limit, therefore the Average value compliance with the average limit

Test Mode	IEEE 802.11n HT20 / 5220MHZ	Temp/Hum	22(°C)/ 34%RH
Test Item	Harmonic	Test Date	July 30, 2018
Polarize	Horizontal	Test Engineer	Jerry Chuang
Detector	Peak and Average		

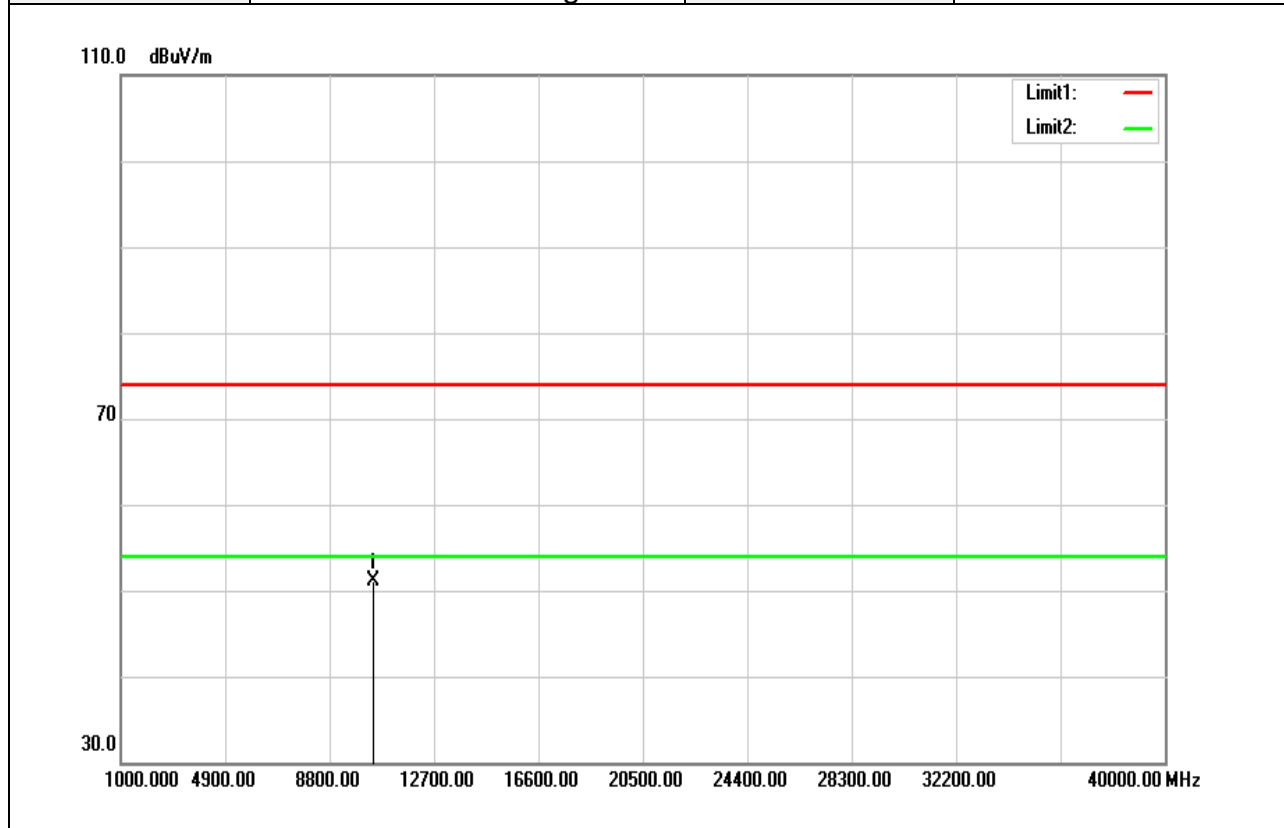

Frequency (MHz)	Reading (dBuV)	Correct Factor (dB/m)	Result (dBuV/m)	Limit (dBuV/m)	Margin (dB)	Remark
10430.000	36.44	14.67	51.11	74.00	-22.89	peak
N/A						

Remark:

1. Measuring frequencies from 1 GHz to the 10th harmonic of highest fundamental frequency.
2. For above 1GHz, the EUT peak value was under average limit, therefore the Average value compliance with the average limit

Test Mode	IEEE 802.11n HT20 / 5240MHZ	Temp/Hum	22(°C)/ 34%RH
Test Item	Harmonic	Test Date	July 30, 2018
Polarize	Vertical	Test Engineer	Jerry Chuang
Detector	Peak and Average		

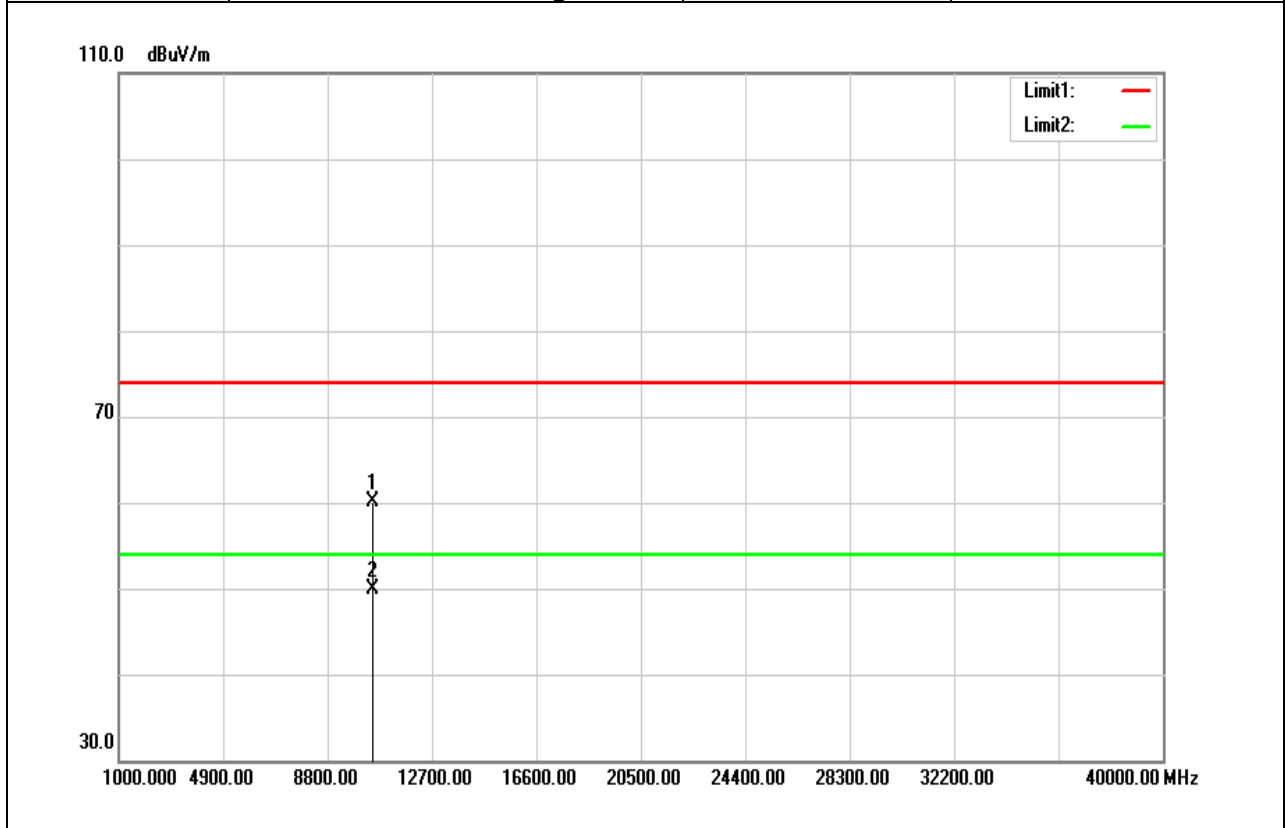

Frequency (MHz)	Reading (dBuV)	Correct Factor (dB/m)	Result (dBuV/m)	Limit (dBuV/m)	Margin (dB)	Remark
10480.000	45.29	14.84	60.13	74.00	-13.87	peak
10480.000	35.01	14.84	49.85	54.00	-4.15	AVG
N/A						

Remark:

1. Measuring frequencies from 1 GHz to the 10th harmonic of highest fundamental frequency.
2. For above 1GHz, the EUT peak value was under average limit, therefore the Average value compliance with the average limit

Test Mode	IEEE 802.11n HT20 / 5240MHZ	Temp/Hum	22(°C)/ 34%RH
Test Item	Harmonic	Test Date	July 30, 2018
Polarize	Horizontal	Test Engineer	Jerry Chuang
Detector	Peak and Average		

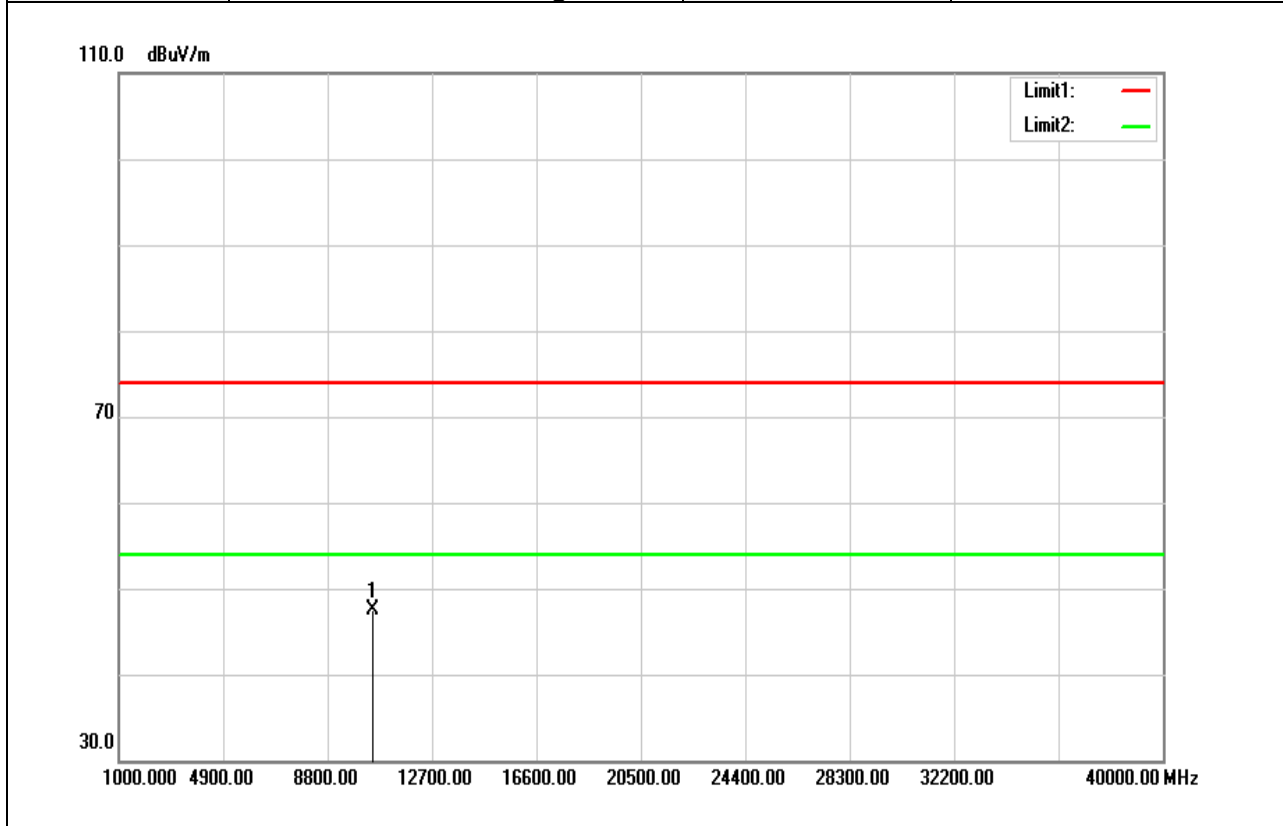

Frequency (MHz)	Reading (dBuV)	Correct Factor (dB/m)	Result (dBuV/m)	Limit (dBuV/m)	Margin (dB)	Remark
10480.000	32.72	14.84	47.56	74.00	-26.44	peak
N/A						

Remark:

1. Measuring frequencies from 1 GHz to the 10th harmonic of highest fundamental frequency.
2. For above 1GHz, the EUT peak value was under average limit, therefore the Average value compliance with the average limit

Test Mode	IEEE 802.11n HT40 / 5190MHZ	Temp/Hum	22(°C)/ 34%RH
Test Item	Harmonic	Test Date	July 30, 2018
Polarize	Vertical	Test Engineer	Jerry Chuang
Detector	Peak and Average		

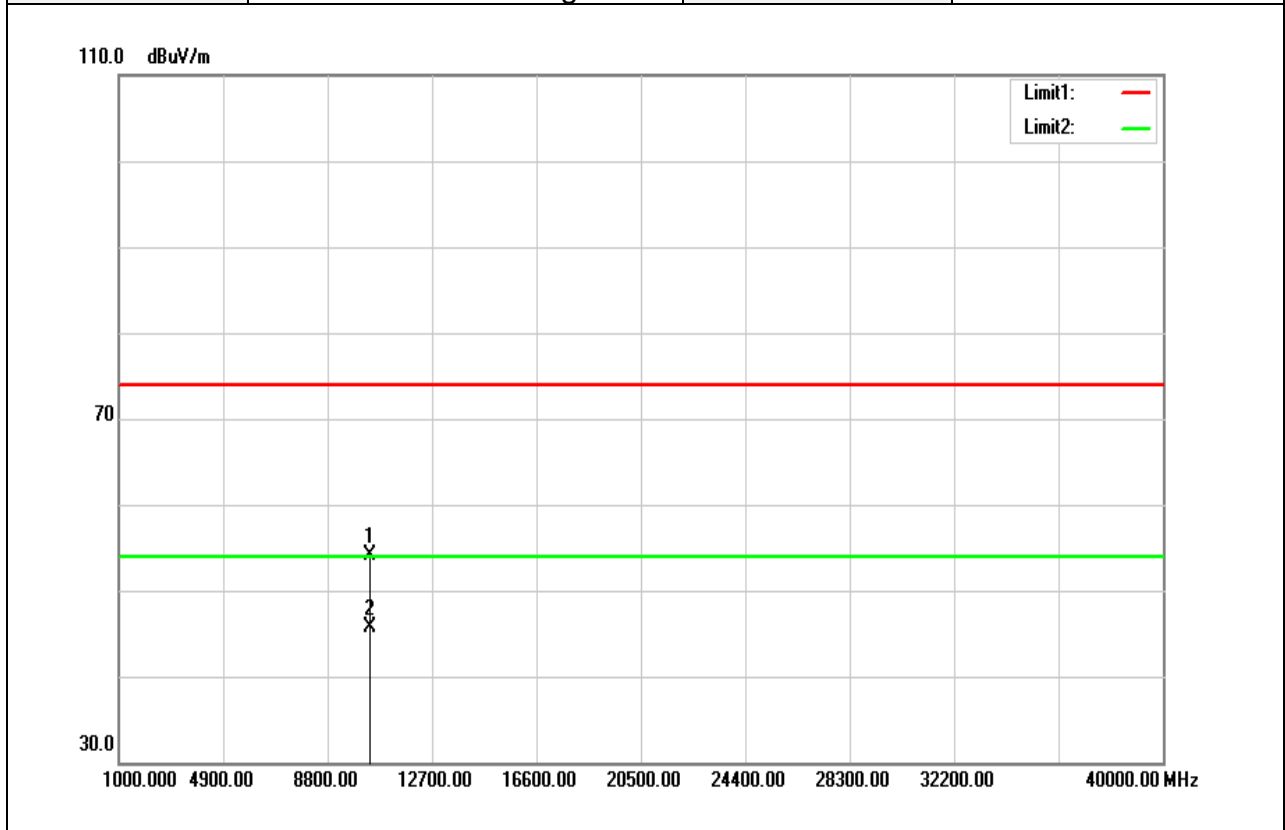

Frequency (MHz)	Reading (dBuV)	Correct Factor (dB/m)	Result (dBuV/m)	Limit (dBuV/m)	Margin (dB)	Remark
10380.000	39.52	14.50	54.02	74.00	-19.98	peak
10380.000	31.18	14.50	45.68	54.00	-8.32	AVG
N/A						

Remark:

1. Measuring frequencies from 1 GHz to the 10th harmonic of highest fundamental frequency.
2. For above 1GHz, the EUT peak value was under average limit, therefore the Average value compliance with the average limit

Report No.: T180627D11-RP4

Test Mode	IEEE 802.11n HT40 / 5190MHZ	Temp/Hum	22(°C)/ 34%RH
Test Item	Harmonic	Test Date	July 30, 2018
Polarize	Horizontal	Test Engineer	Jerry Chuang
Detector	Peak and Average		

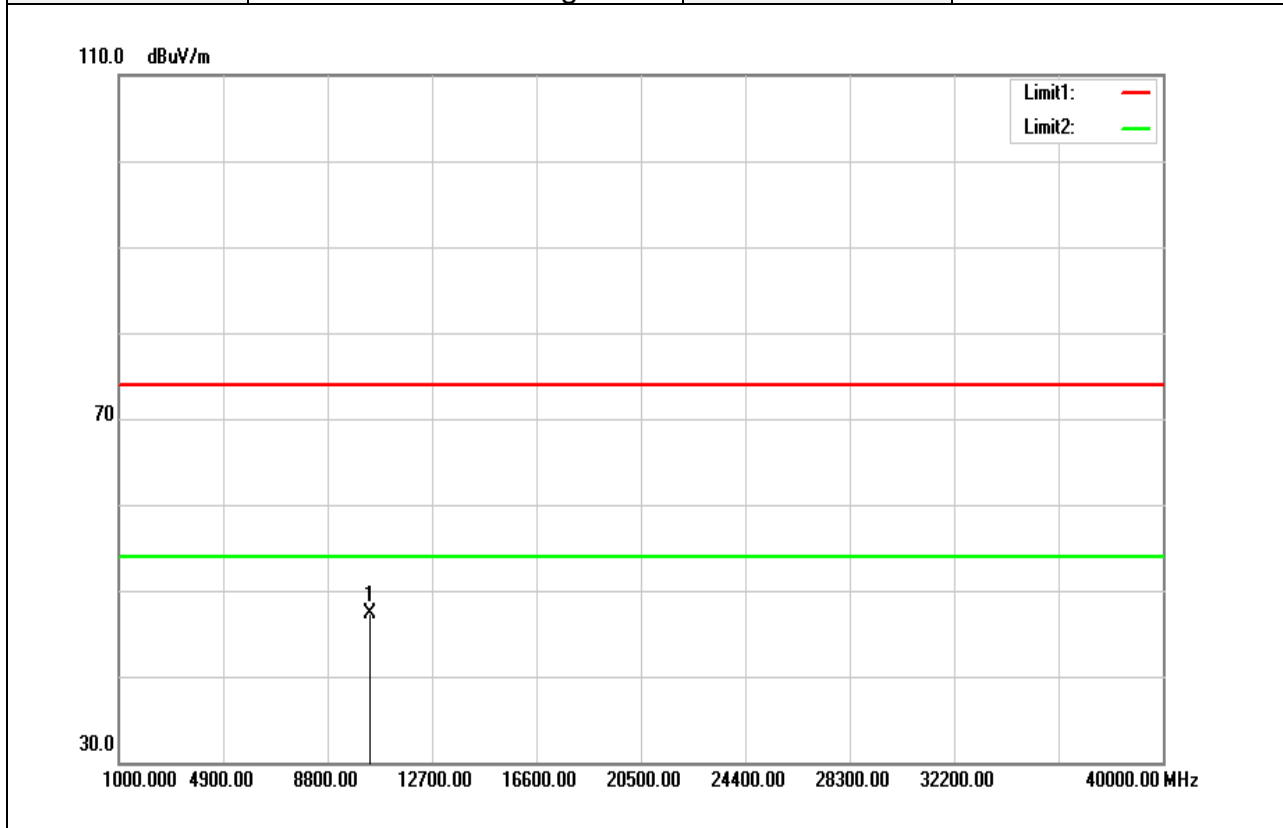

Frequency (MHz)	Reading (dBuV)	Correct Factor (dB/m)	Result (dBuV/m)	Limit (dBuV/m)	Margin (dB)	Remark
10380.000	32.70	14.50	47.20	74.00	-26.80	peak
N/A						

Remark:

- Measuring frequencies from 1 GHz to the 10th harmonic of highest fundamental frequency.
- For above 1GHz, the EUT peak value was under average limit, therefore the Average value compliance with the average limit

Test Mode	IEEE 802.11n HT40 / 5230MHZ	Temp/Hum	22(°C)/ 34%RH
Test Item	Harmonic	Test Date	July 30, 2018
Polarize	Vertical	Test Engineer	Jerry Chuang
Detector	Peak and Average		

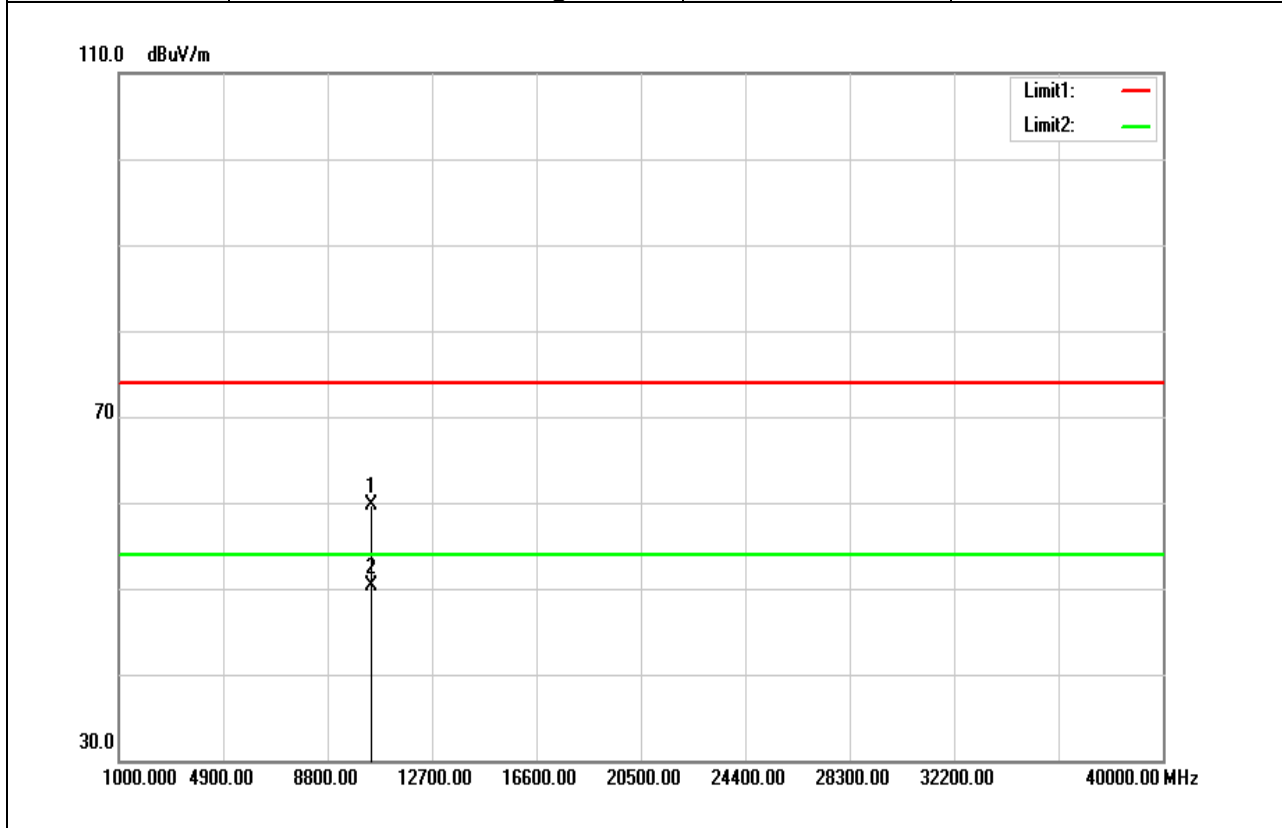

Frequency (MHz)	Reading (dBuV)	Correct Factor (dB/m)	Result (dBuV/m)	Limit (dBuV/m)	Margin (dB)	Remark
10460.000	44.93	14.79	59.72	74.00	-14.28	peak
10460.000	35.58	14.79	50.37	54.00	-3.63	AVG
N/A						

Remark:

1. Measuring frequencies from 1 GHz to the 10th harmonic of highest fundamental frequency.
2. For above 1GHz, the EUT peak value was under average limit, therefore the Average value compliance with the average limit

Test Mode	IEEE 802.11n HT40 / 5230MHZ	Temp/Hum	22(°C)/ 34%RH
Test Item	Harmonic	Test Date	July 30, 2018
Polarize	Horizontal	Test Engineer	Jerry Chuang
Detector	Peak and Average		

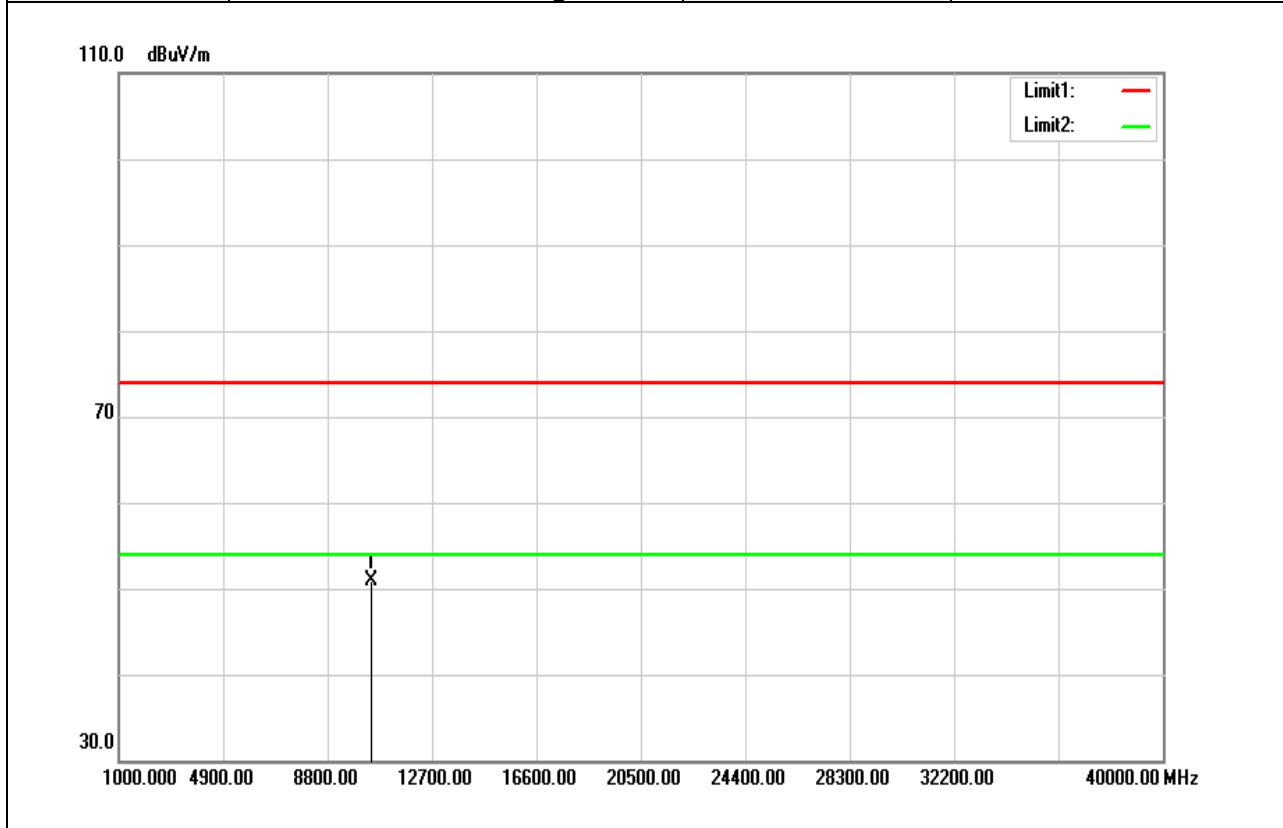

Frequency (MHz)	Reading (dBuV)	Correct Factor (dB/m)	Result (dBuV/m)	Limit (dBuV/m)	Margin (dB)	Remark
10460.000	36.21	14.79	51.00	74.00	-23.00	peak
N/A						

Remark:

- Measuring frequencies from 1 GHz to the 10th harmonic of highest fundamental frequency.
- For above 1GHz, the EUT peak value was under average limit, therefore the Average value compliance with the average limit

Test Mode	IEEE 802.11ac VHT80 / 5210MHZ	Temp/Hum	22(°C)/ 34%RH
Test Item	Harmonic	Test Date	July 30, 2018
Polarize	Vertical	Test Engineer	Jerry Chuang
Detector	Peak and Average		

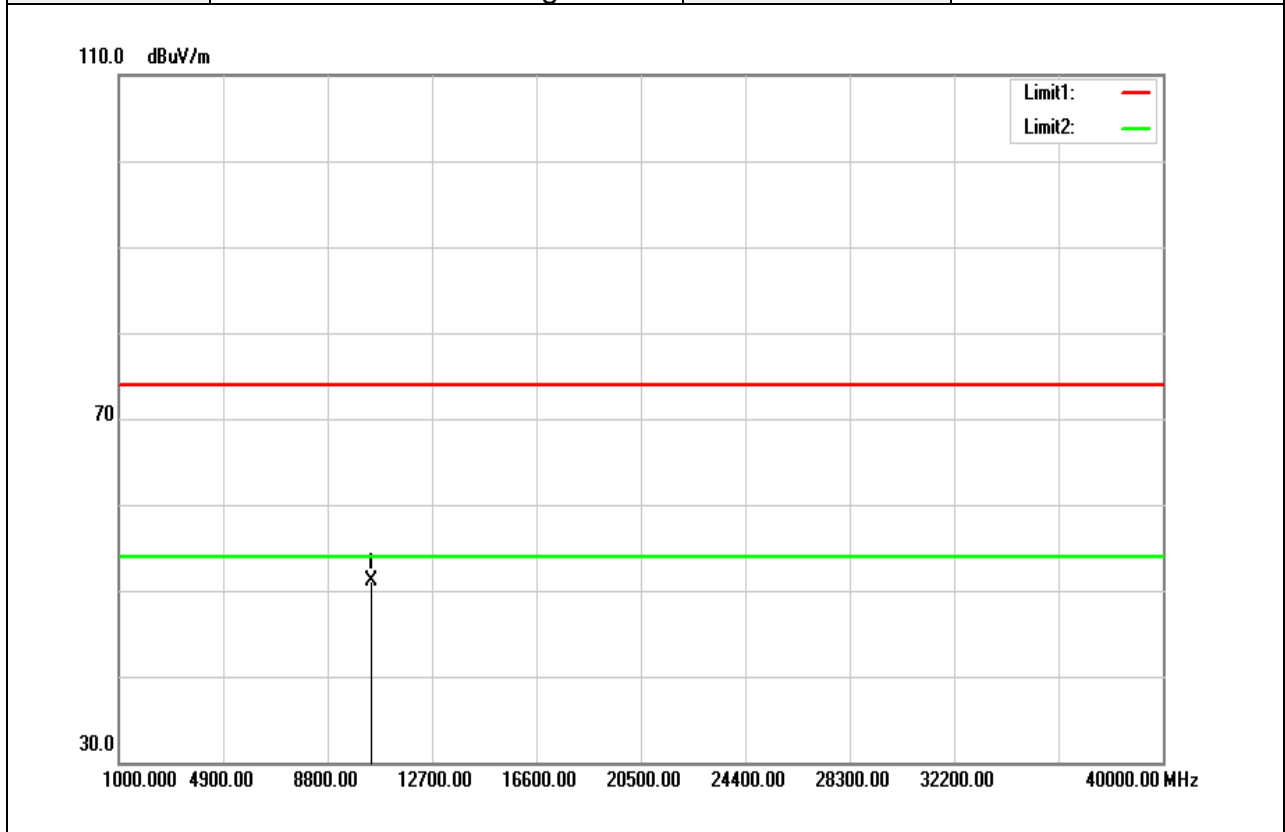

Frequency (MHz)	Reading (dBuV)	Correct Factor (dB/m)	Result (dBuV/m)	Limit (dBuV/m)	Margin (dB)	Remark
10420.000	36.52	14.66	51.18	74.00	-22.82	peak
N/A						

Remark:

- Measuring frequencies from 1 GHz to the 10th harmonic of highest fundamental frequency.
- For above 1GHz, the EUT peak value was under average limit, therefore the Average value compliance with the average limit

Test Mode	IEEE 802.11ac VHT80 / 5210MHZ	Temp/Hum	22(°C)/ 34%RH
Test Item	Harmonic	Test Date	July 30, 2018
Polarize	Horizontal	Test Engineer	Jerry Chuang
Detector	Peak and Average		

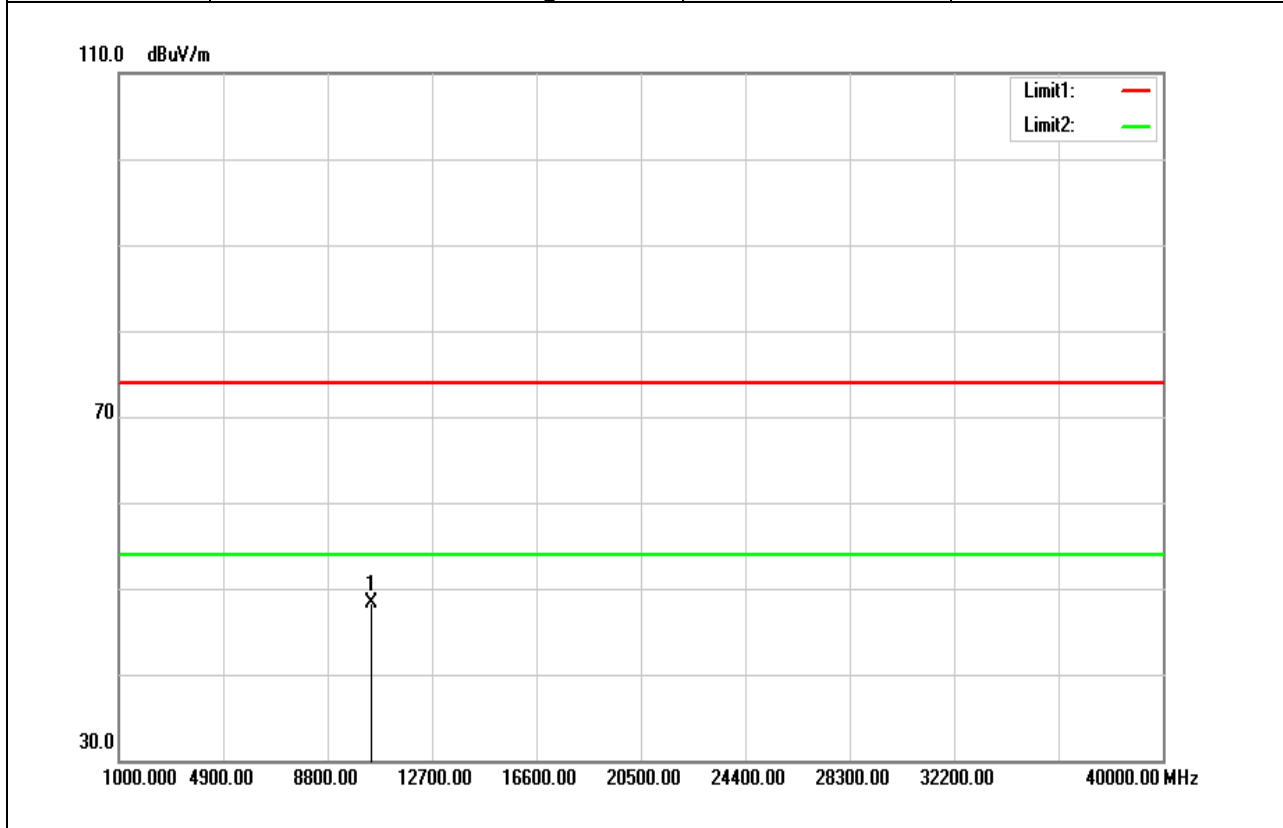

Frequency (MHz)	Reading (dBuV)	Correct Factor (dB/m)	Result (dBuV/m)	Limit (dBuV/m)	Margin (dB)	Remark
10420.000	33.65	14.66	48.31	74.00	-25.69	peak
N/A						

Remark:

1. Measuring frequencies from 1 GHz to the 10th harmonic of highest fundamental frequency.
2. For above 1GHz, the EUT peak value was under average limit, therefore the Average value compliance with the average limit

Above 1G Test Data for UNII-3

Test Mode	IEEE 802.11a / 5745 MHz	Temp/Hum	22(°C)/ 34%RH
Test Item	Harmonic	Test Date	July 30, 2018
Polarize	Vertical	Test Engineer	Jerry Chuang
Detector	Peak and Average		

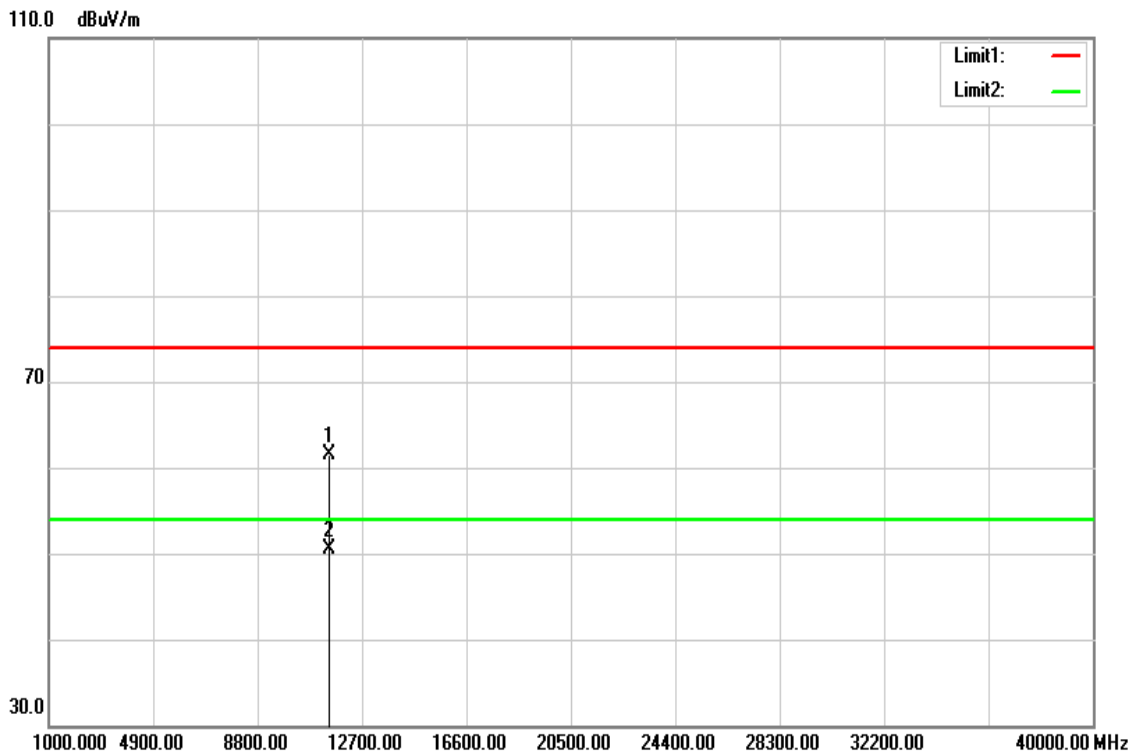

Frequency (MHz)	Reading (dBuV)	Correct Factor (dB/m)	Result (dBuV/m)	Limit (dBuV/m)	Margin (dB)	Remark
11490.000	45.38	16.09	61.47	74.00	-12.53	peak
11490.000	34.37	16.09	50.46	54.00	-3.54	AVG
N/A						

Remark:

1. Measuring frequencies from 1 GHz to the 10th harmonic of highest fundamental frequency.
2. For above 1GHz, the EUT peak value was under average limit, therefore the Average value compliance with the average limit

Report No.: T180627D11-RP4

Test Mode	IEEE 802.11a / 5745 MHz	Temp/Hum	22(°C)/ 34%RH
Test Item	Harmonic	Test Date	July 30, 2018
Polarize	Horizontal	Test Engineer	Jerry Chuang
Detector	Peak and Average		

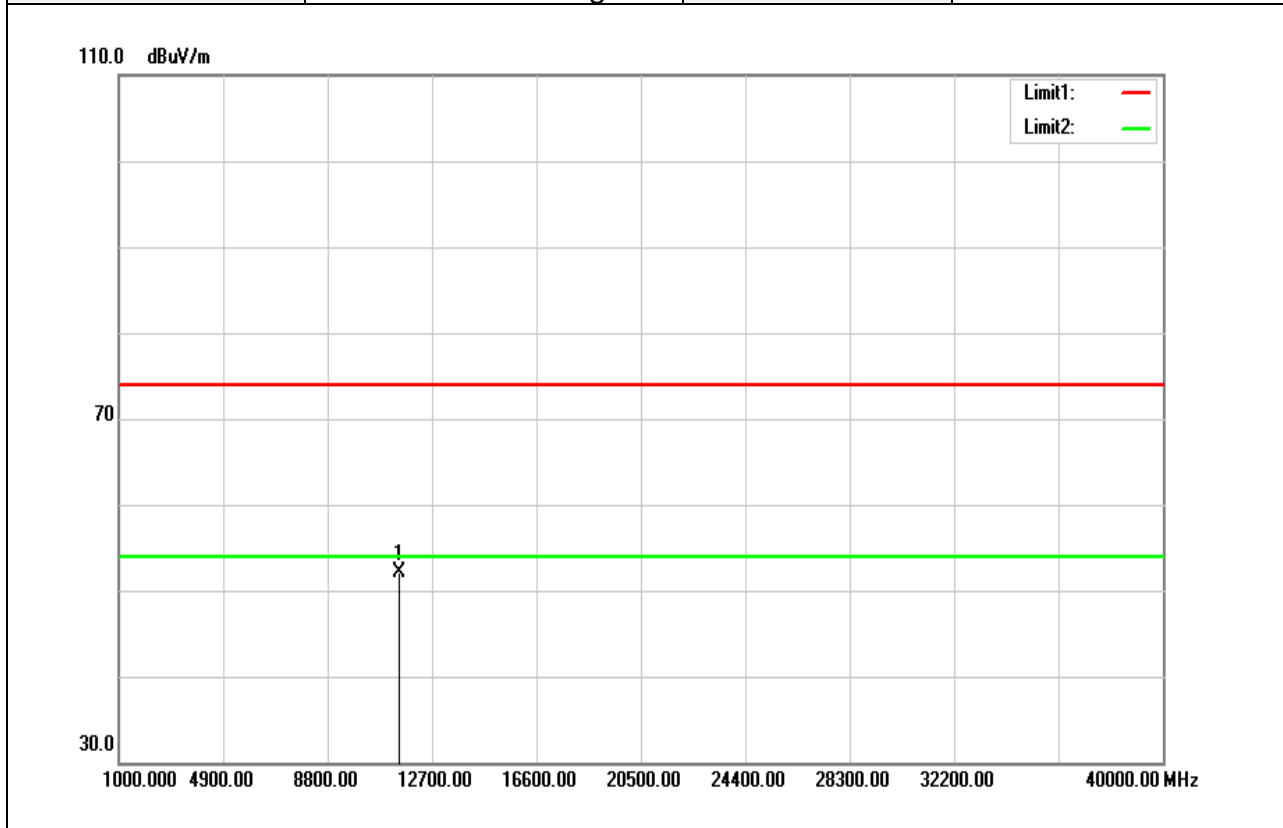

Frequency (MHz)	Reading (dBuV)	Correct Factor (dB/m)	Result (dBuV/m)	Limit (dBuV/m)	Margin (dB)	Remark
11490.000	35.94	16.09	52.03	74.00	-21.97	peak
N/A						

Remark:

1. Measuring frequencies from 1 GHz to the 10th harmonic of highest fundamental frequency.
2. For above 1GHz, the EUT peak value was under average limit, therefore the Average value compliance with the average limit

Report No.: T180627D11-RP4

Test Mode	IEEE 802.11a / 5785 MHz	Temp/Hum	22(°C)/ 34%RH
Test Item	Harmonic	Test Date	July 30, 2018
Polarize	Vertical	Test Engineer	Jerry Chuang
Detector	Peak and Average		

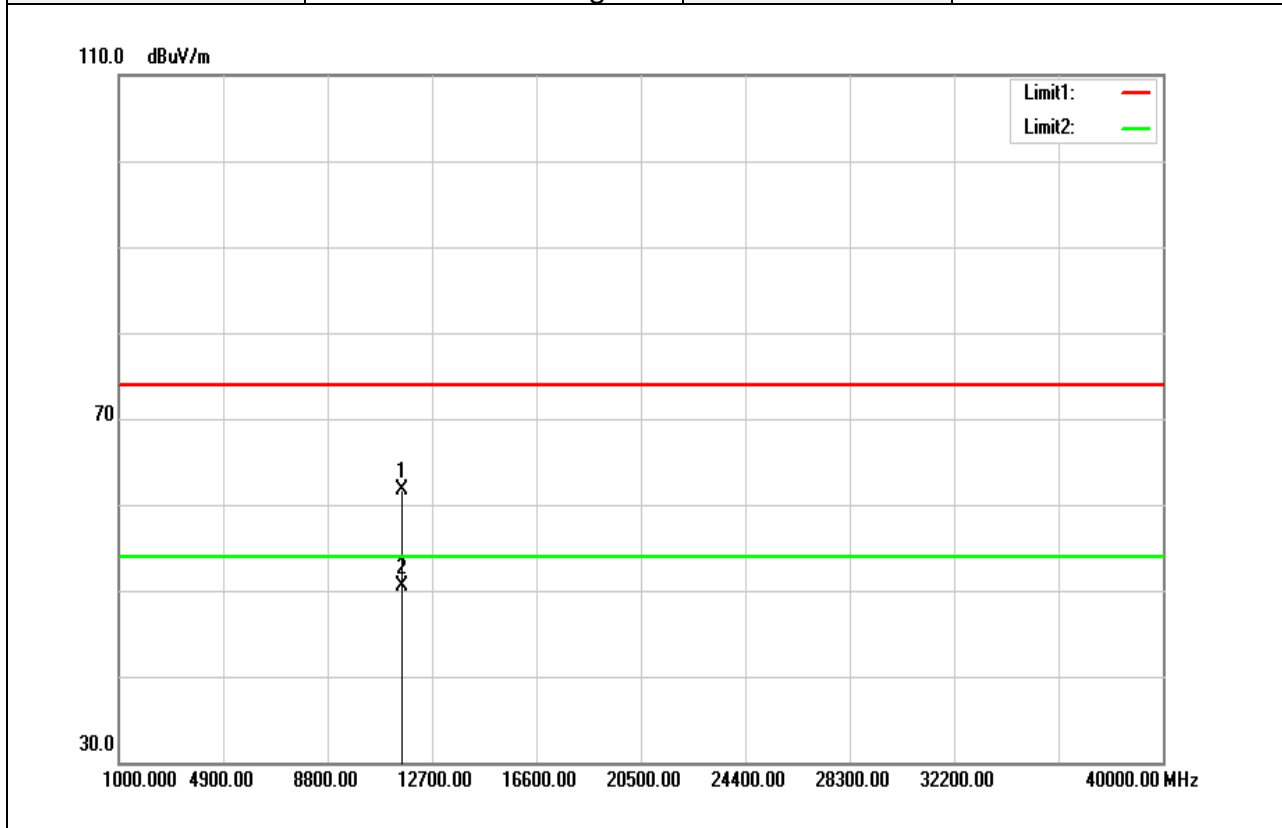

Frequency (MHz)	Reading (dBuV)	Correct Factor (dB/m)	Result (dBuV/m)	Limit (dBuV/m)	Margin (dB)	Remark
11570.000	45.64	16.01	61.65	74.00	-12.35	peak
11570.000	34.47	16.01	50.48	54.00	-3.52	AVG
N/A						

Remark:

1. Measuring frequencies from 1 GHz to the 10th harmonic of highest fundamental frequency.
2. For above 1GHz, the EUT peak value was under average limit, therefore the Average value compliance with the average limit

Report No.: T180627D11-RP4

Test Mode	IEEE 802.11a / 5785 MHz	Temp/Hum	22(°C)/ 34%RH
Test Item	Harmonic	Test Date	July 30, 2018
Polarize	Horizontal	Test Engineer	Jerry Chuang
Detector	Peak and Average		

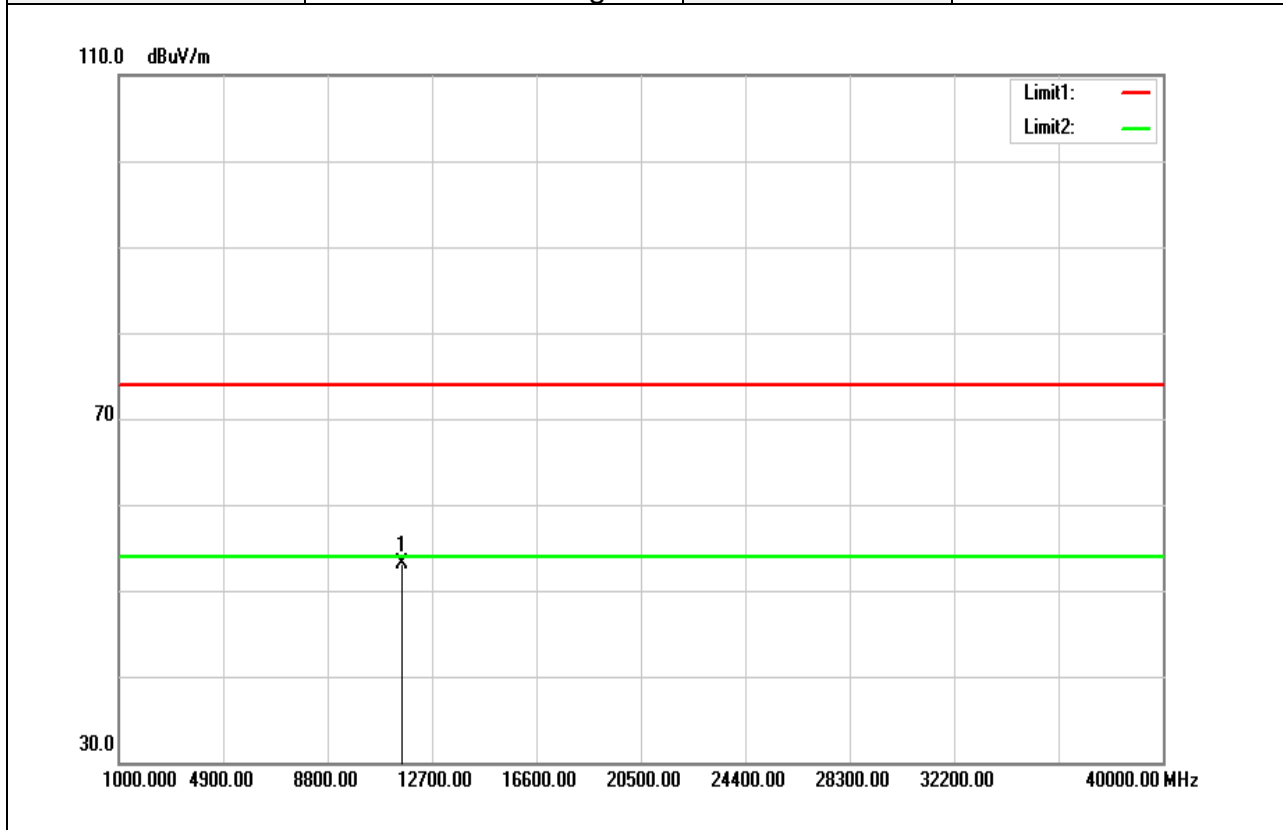

Frequency (MHz)	Reading (dBuV)	Correct Factor (dB/m)	Result (dBuV/m)	Limit (dBuV/m)	Margin (dB)	Remark
11570.000	37.10	16.01	53.11	74.00	-20.89	peak
N/A						

Remark:

1. Measuring frequencies from 1 GHz to the 10th harmonic of highest fundamental frequency.
2. For above 1GHz, the EUT peak value was under average limit, therefore the Average value compliance with the average limit

Report No.: T180627D11-RP4

Test Mode	IEEE 802.11a / 5825 MHz	Temp/Hum	22(°C)/ 34%RH
Test Item	Harmonic	Test Date	July 30, 2018
Polarize	Vertical	Test Engineer	Jerry Chuang
Detector	Peak and Average		

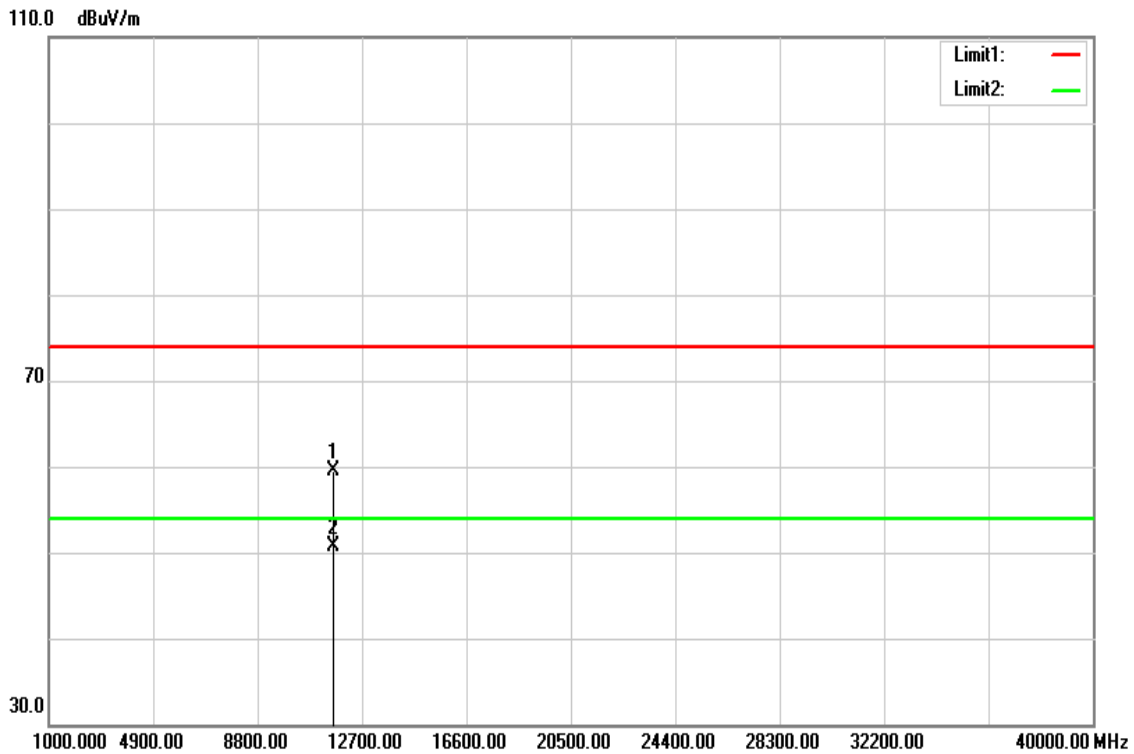

Frequency (MHz)	Reading (dBuV)	Correct Factor (dB/m)	Result (dBuV/m)	Limit (dBuV/m)	Margin (dB)	Remark
11650.000	43.64	15.93	59.57	74.00	-14.43	peak
11650.000	34.84	15.93	50.77	54.00	-3.23	AVG
N/A						

Remark:

1. Measuring frequencies from 1 GHz to the 10th harmonic of highest fundamental frequency.
2. For above 1GHz, the EUT peak value was under average limit, therefore the Average value compliance with the average limit

Report No.: T180627D11-RP4

Test Mode	IEEE 802.11a / 5825 MHz	Temp/Hum	22(°C)/ 34%RH
Test Item	Harmonic	Test Date	July 30, 2018
Polarize	Horizontal	Test Engineer	Jerry Chuang
Detector	Peak and Average		

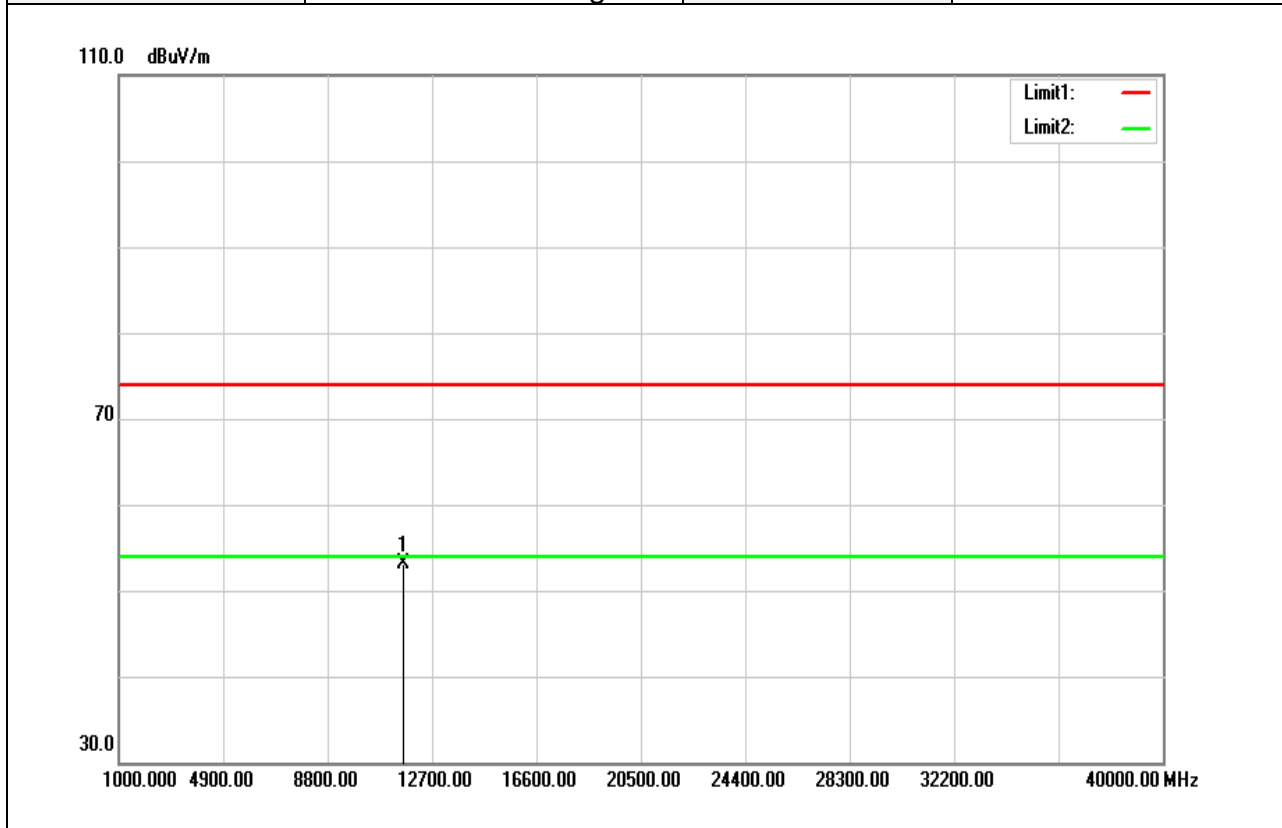

Frequency (MHz)	Reading (dBuV)	Correct Factor (dB/m)	Result (dBuV/m)	Limit (dBuV/m)	Margin (dB)	Remark
11650.000	37.09	15.93	53.02	74.00	-20.98	peak
N/A						

Remark:

- Measuring frequencies from 1 GHz to the 10th harmonic of highest fundamental frequency.
- For above 1GHz, the EUT peak value was under average limit, therefore the Average value compliance with the average limit

Test Mode	IEEE 802.11n HT20 / 5745 MHz	Temp/Hum	22(°C)/ 34%RH
Test Item	Harmonic	Test Date	July 30, 2018
Polarize	Vertical	Test Engineer	Jerry Chuang
Detector	Peak and Average		

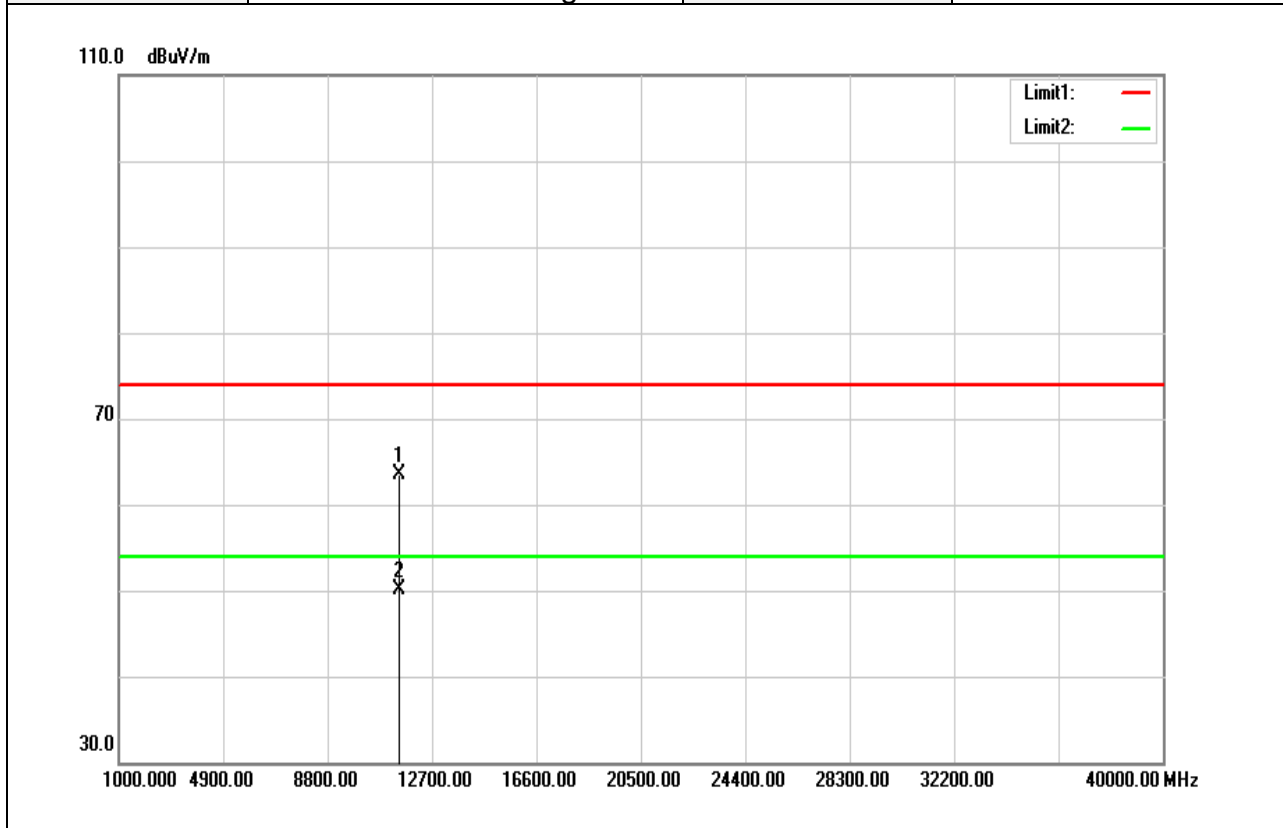

Frequency (MHz)	Reading (dBuV)	Correct Factor (dB/m)	Result (dBuV/m)	Limit (dBuV/m)	Margin (dB)	Remark
11490.000	47.41	16.09	63.50	74.00	-10.50	peak
11490.000	34.09	16.09	50.18	54.00	-3.82	AVG
N/A						

Remark:

1. Measuring frequencies from 1 GHz to the 10th harmonic of highest fundamental frequency.
2. For above 1GHz, the EUT peak value was under average limit, therefore the Average value compliance with the average limit

Test Mode	IEEE 802.11n HT20 / 5745 MHz	Temp/Hum	22(°C)/ 34%RH
Test Item	Harmonic	Test Date	July 30, 2018
Polarize	Horizontal	Test Engineer	Jerry Chuang
Detector	Peak and Average		

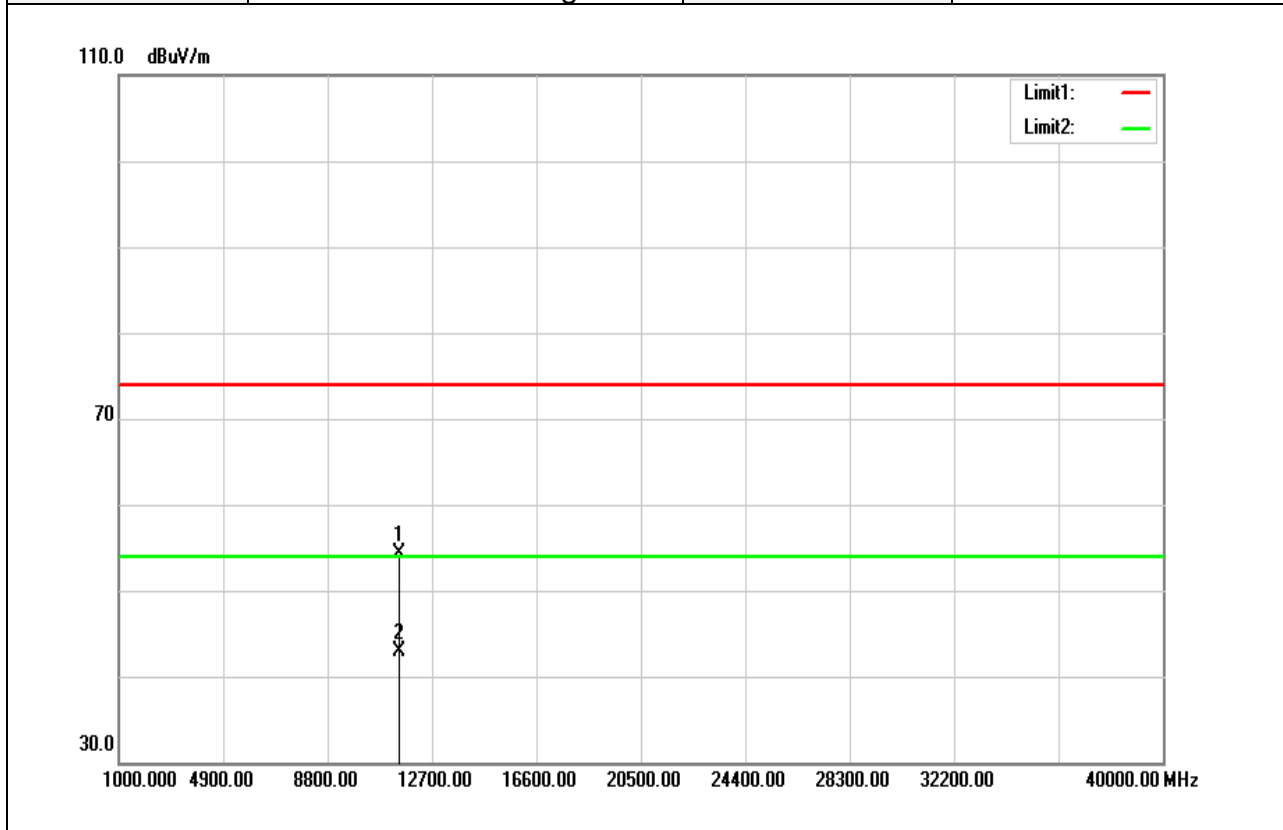

Frequency (MHz)	Reading (dBuV)	Correct Factor (dB/m)	Result (dBuV/m)	Limit (dBuV/m)	Margin (dB)	Remark
11490.000	38.31	16.09	54.40	74.00	-19.60	peak
11490.000	26.76	16.09	42.85	54.00	-11.15	AVG
N/A						

Remark:

1. Measuring frequencies from 1 GHz to the 10th harmonic of highest fundamental frequency.
2. For above 1GHz, the EUT peak value was under average limit, therefore the Average value compliance with the average limit

Report No.: T180627D11-RP4

Test Mode	IEEE 802.11n HT20/ 5785 MHz	Temp/Hum	22(°C)/ 34%RH
Test Item	Harmonic	Test Date	July 30, 2018
Polarize	Vertical	Test Engineer	Jerry Chuang
Detector	Peak and Average		

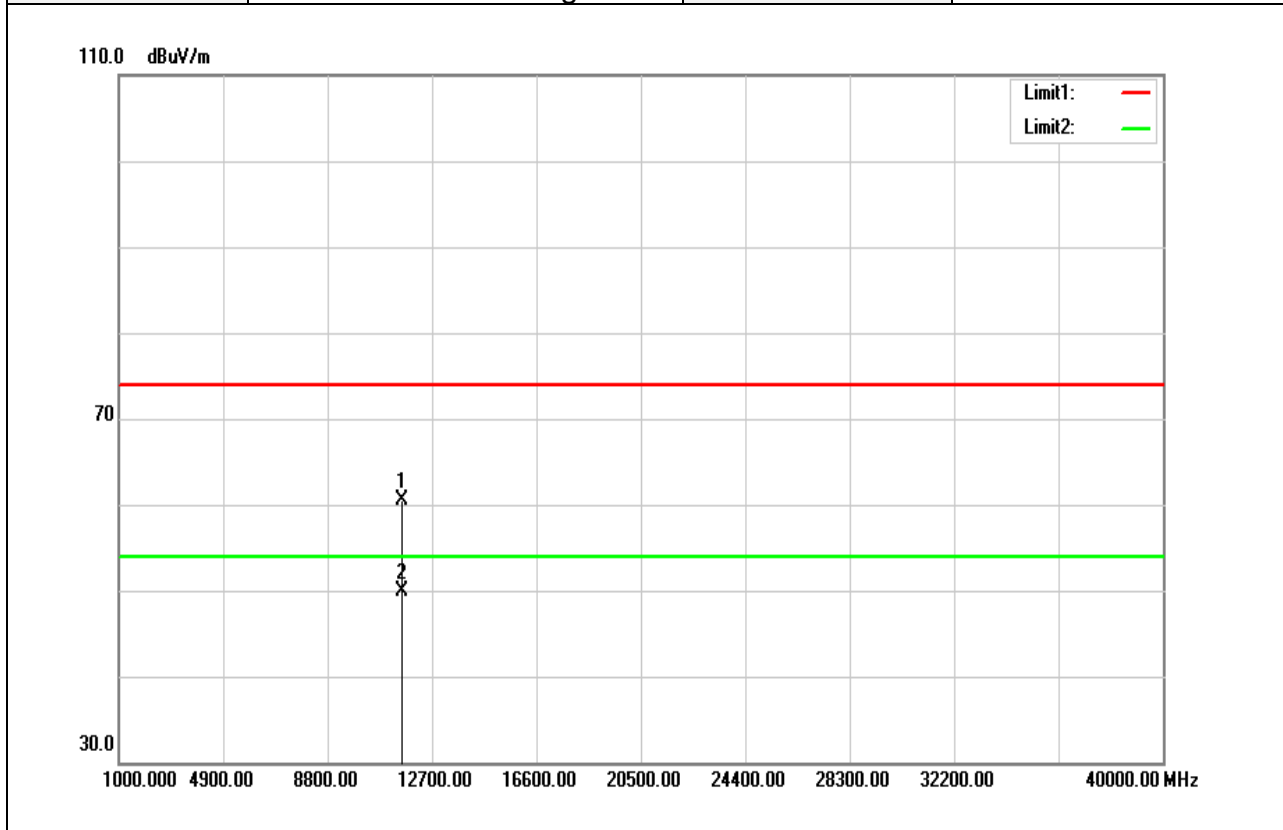

Frequency (MHz)	Reading (dBuV)	Correct Factor (dB/m)	Result (dBuV/m)	Limit (dBuV/m)	Margin (dB)	Remark
11570.000	44.53	16.01	60.54	74.00	-13.46	peak
11570.000	33.94	16.01	49.95	54.00	-4.05	AVG
N/A						

Remark:

- Measuring frequencies from 1 GHz to the 10th harmonic of highest fundamental frequency.
- For above 1GHz, the EUT peak value was under average limit, therefore the Average value compliance with the average limit

Test Mode	IEEE 802.11n HT20/ 5785 MHz	Temp/Hum	22(°C)/ 34%RH
Test Item	Harmonic	Test Date	July 30, 2018
Polarize	Horizontal	Test Engineer	Jerry Chuang
Detector	Peak and Average		

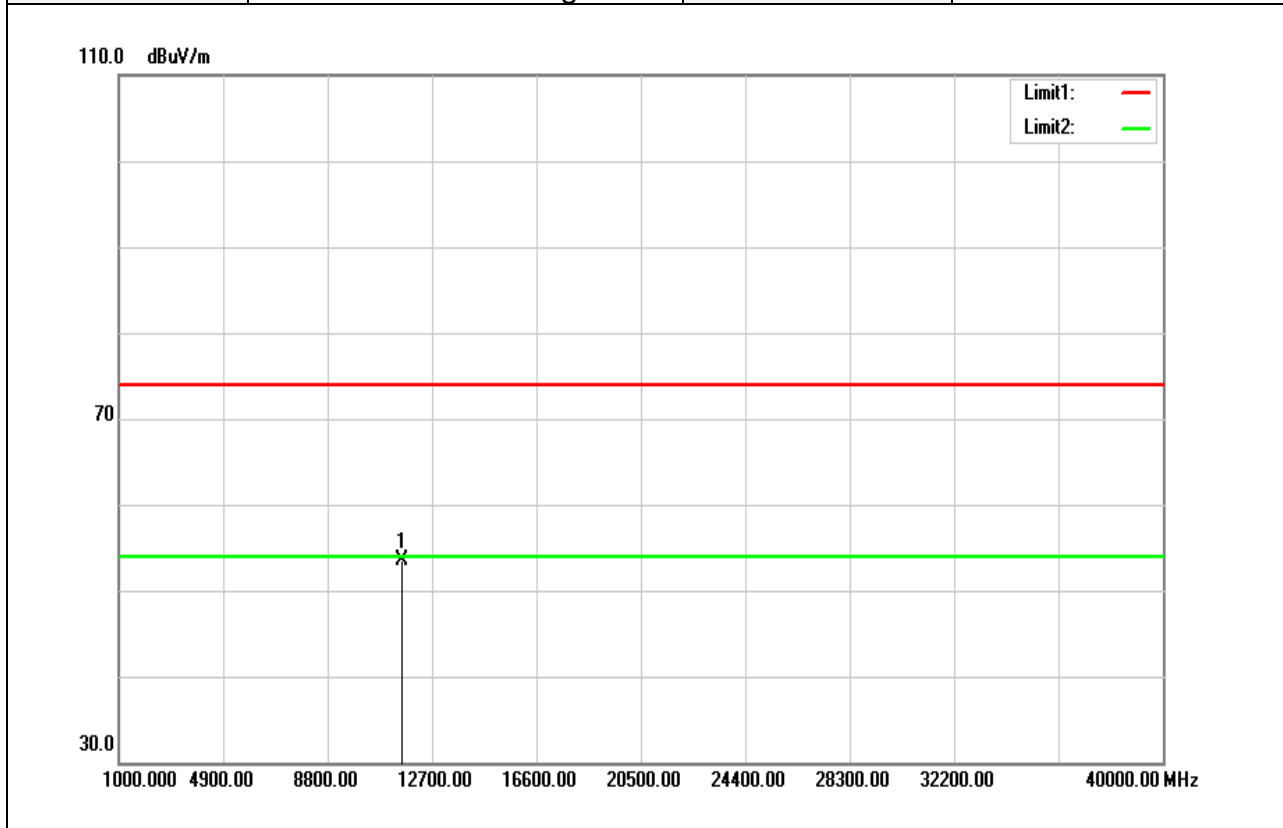

Frequency (MHz)	Reading (dBuV)	Correct Factor (dB/m)	Result (dBuV/m)	Limit (dBuV/m)	Margin (dB)	Remark
11570.000	37.50	16.01	53.51	74.00	-20.49	peak
N/A						

Remark:

1. Measuring frequencies from 1 GHz to the 10th harmonic of highest fundamental frequency.
2. For above 1GHz, the EUT peak value was under average limit, therefore the Average value compliance with the average limit

Report No.: T180627D11-RP4

Test Mode	IEEE 802.11n HT20/ 5825 MHz	Temp/Hum	22(°C)/ 34%RH
Test Item	Harmonic	Test Date	July 30, 2018
Polarize	Vertical	Test Engineer	Jerry Chuang
Detector	Peak and Average		

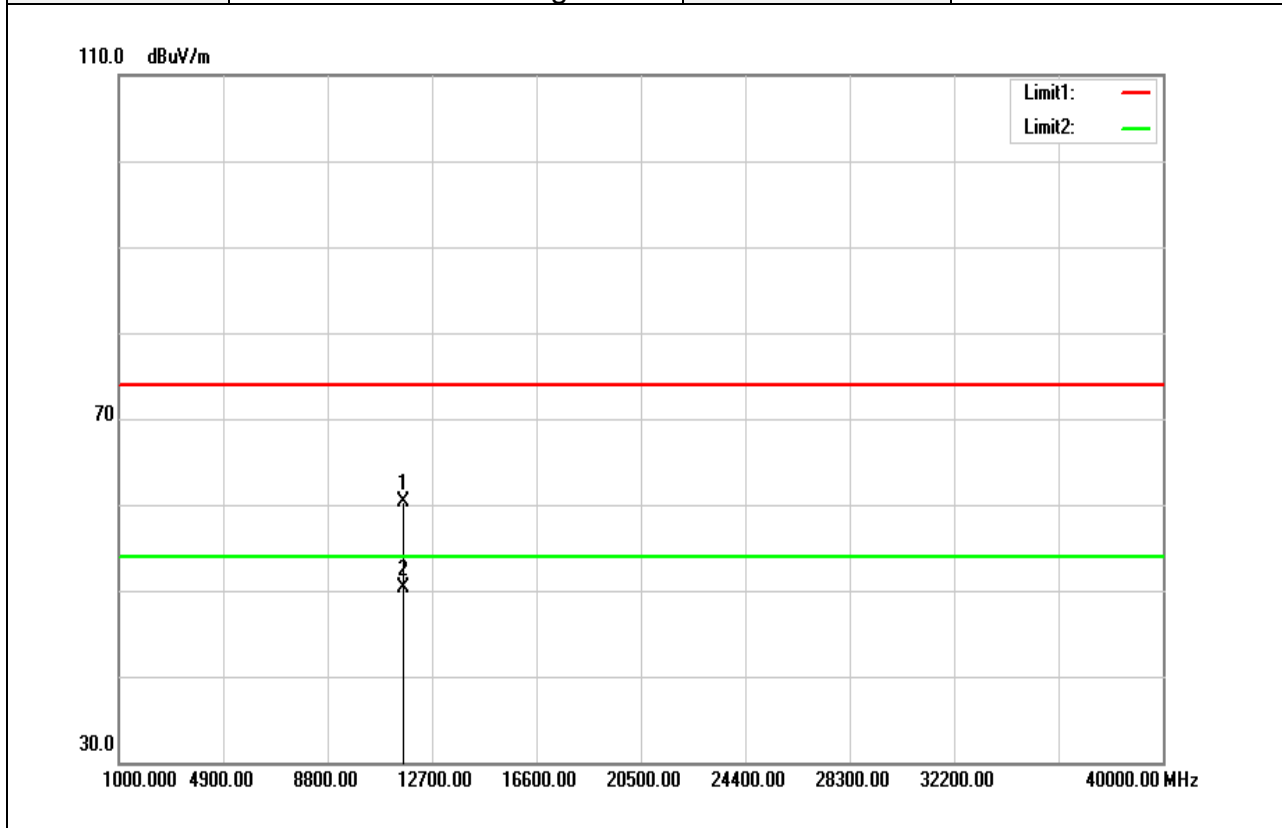

Frequency (MHz)	Reading (dBuV)	Correct Factor (dB/m)	Result (dBuV/m)	Limit (dBuV/m)	Margin (dB)	Remark
11650.000	44.41	15.93	60.34	74.00	-13.66	peak
11650.000	34.29	15.93	50.22	54.00	-3.78	AVG
N/A						

Remark:

1. Measuring frequencies from 1 GHz to the 10th harmonic of highest fundamental frequency.
2. For above 1GHz, the EUT peak value was under average limit, therefore the Average value compliance with the average limit

Test Mode	IEEE 802.11n HT20/ 5825 MHz	Temp/Hum	22(°C)/ 34%RH
Test Item	Harmonic	Test Date	July 30, 2018
Polarize	Horizontal	Test Engineer	Jerry Chuang
Detector	Peak and Average		

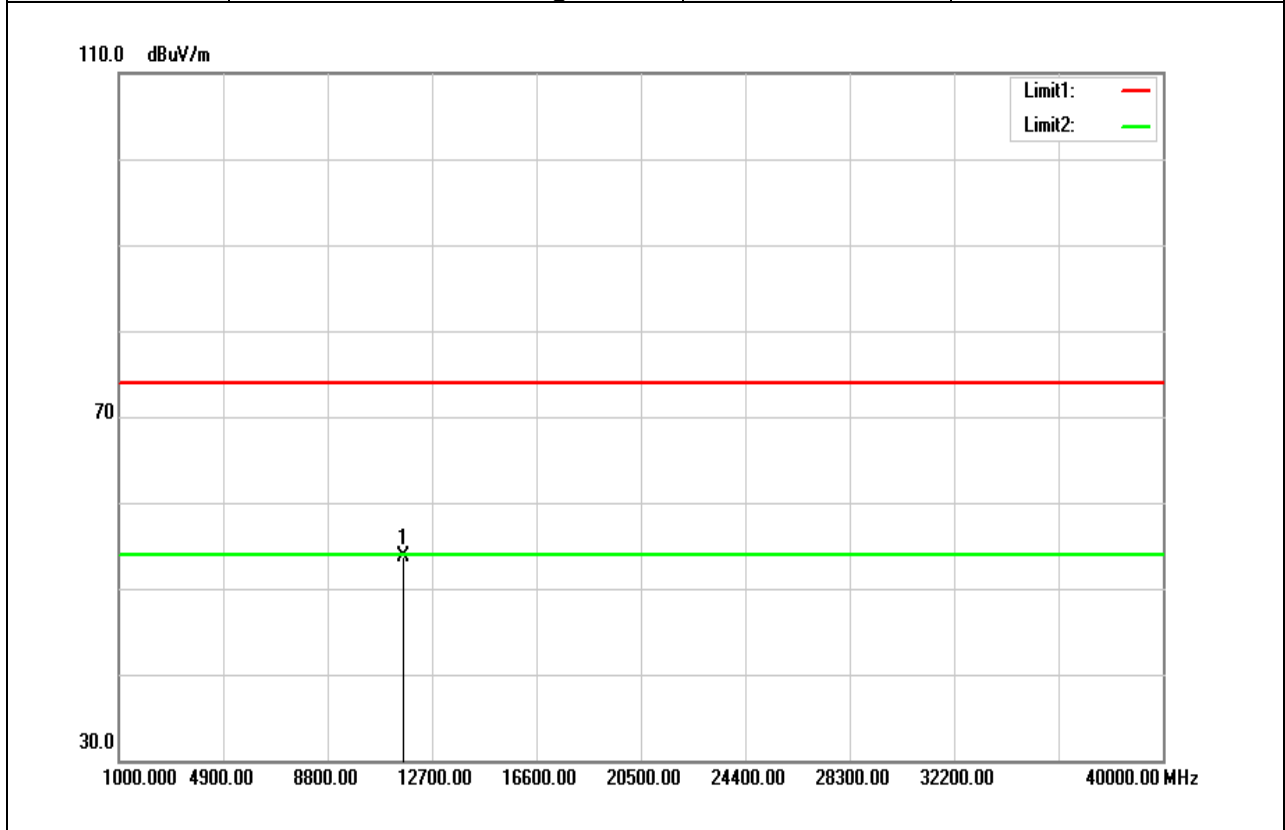

Frequency (MHz)	Reading (dBuV)	Correct Factor (dB/m)	Result (dBuV/m)	Limit (dBuV/m)	Margin (dB)	Remark
11650.000	37.75	15.93	53.68	74.00	-20.32	peak
N/A						

Remark:

- Measuring frequencies from 1 GHz to the 10th harmonic of highest fundamental frequency.
- For above 1GHz, the EUT peak value was under average limit, therefore the Average value compliance with the average limit

Test Mode	IEEE 802.11n HT40/ 5755 MHz	Temp/Hum	22(°C)/ 34%RH
Test Item	Harmonic	Test Date	July 30, 2018
Polarize	Vertical	Test Engineer	Jerry Chuang
Detector	Peak and Average		

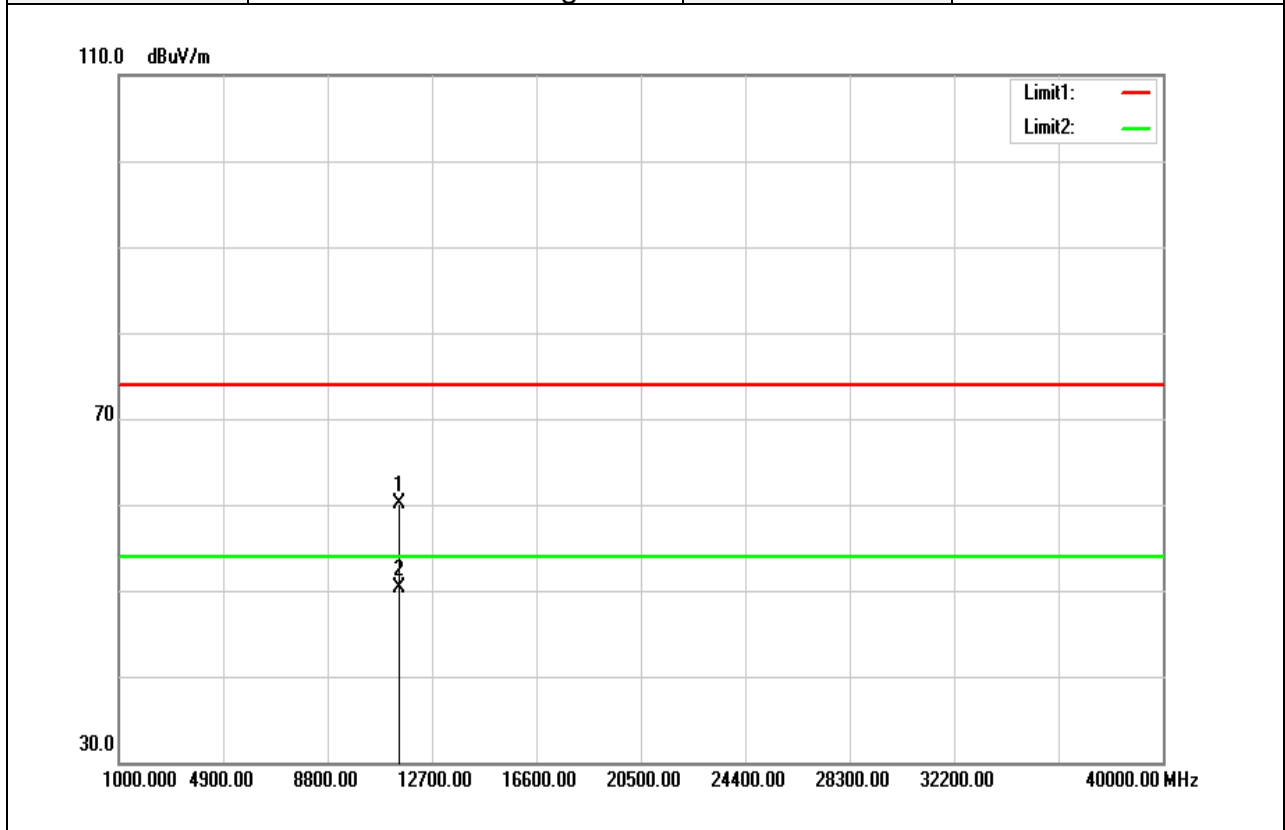

Frequency (MHz)	Reading (dBuV)	Correct Factor (dB/m)	Result (dBuV/m)	Limit (dBuV/m)	Margin (dB)	Remark
11500.000	44.01	16.09	60.10	74.00	-13.90	peak
11500.000	34.12	16.09	50.21	54.00	-3.79	AVG
N/A						

Remark:

- Measuring frequencies from 1 GHz to the 10th harmonic of highest fundamental frequency.
- For above 1GHz, the EUT peak value was under average limit, therefore the Average value compliance with the average limit

Report No.: T180627D11-RP4

Test Mode	IEEE 802.11n HT40/ 5755 MHz	Temp/Hum	22(°C)/ 34%RH
Test Item	Harmonic	Test Date	July 30, 2018
Polarize	Horizontal	Test Engineer	Jerry Chuang
Detector	Peak and Average		

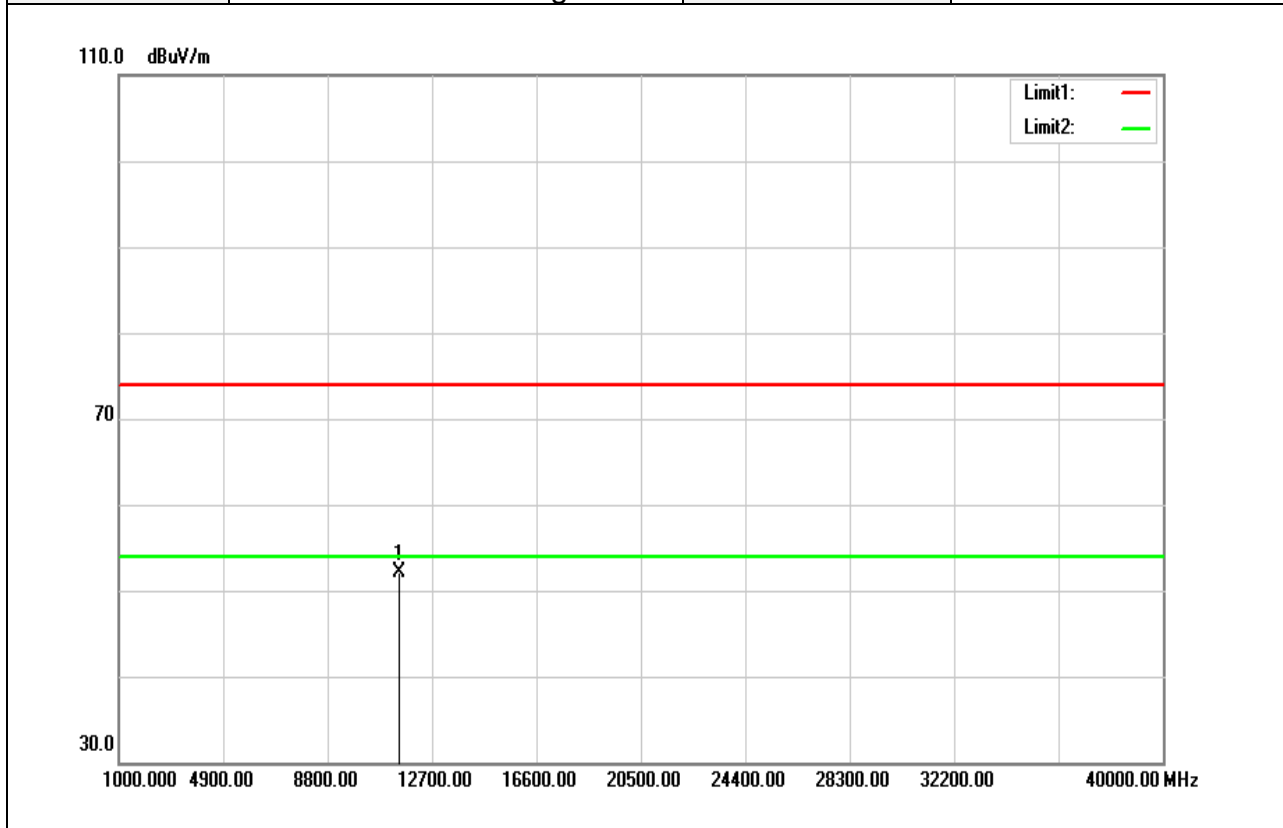

Frequency (MHz)	Reading (dBuV)	Correct Factor (dB/m)	Result (dBuV/m)	Limit (dBuV/m)	Margin (dB)	Remark
11500.000	35.96	16.09	52.05	74.00	-21.95	peak
N/A						

Remark:

1. Measuring frequencies from 1 GHz to the 10th harmonic of highest fundamental frequency.
2. For above 1GHz, the EUT peak value was under average limit, therefore the Average value compliance with the average limit

Report No.: T180627D11-RP4

Test Mode	IEEE 802.11n HT40/ 5795 MHz	Temp/Hum	22(°C)/ 34%RH
Test Item	Harmonic	Test Date	July 30, 2018
Polarize	Vertical	Test Engineer	Jerry Chuang
Detector	Peak and Average		

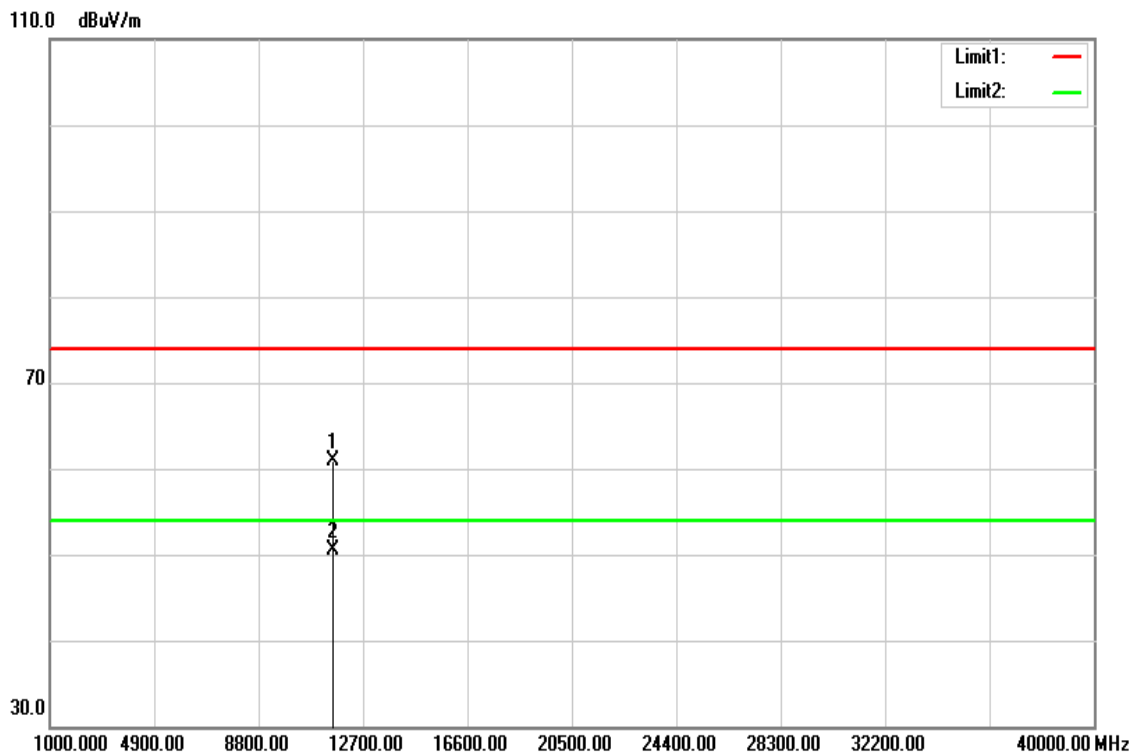

Frequency (MHz)	Reading (dBuV)	Correct Factor (dB/m)	Result (dBuV/m)	Limit (dBuV/m)	Margin (dB)	Remark
11590.000	44.88	16.00	60.88	74.00	-13.12	peak
11590.000	34.55	16.00	50.55	54.00	-3.45	AVG
N/A						

Remark:

- Measuring frequencies from 1 GHz to the 10th harmonic of highest fundamental frequency.
- For above 1GHz, the EUT peak value was under average limit, therefore the Average value compliance with the average limit

Report No.: T180627D11-RP4

Test Mode	IEEE 802.11n HT40/ 5795 MHz	Temp/Hum	22(°C)/ 34%RH
Test Item	Harmonic	Test Date	July 30, 2018
Polarize	Horizontal	Test Engineer	Jerry Chuang
Detector	Peak and Average		

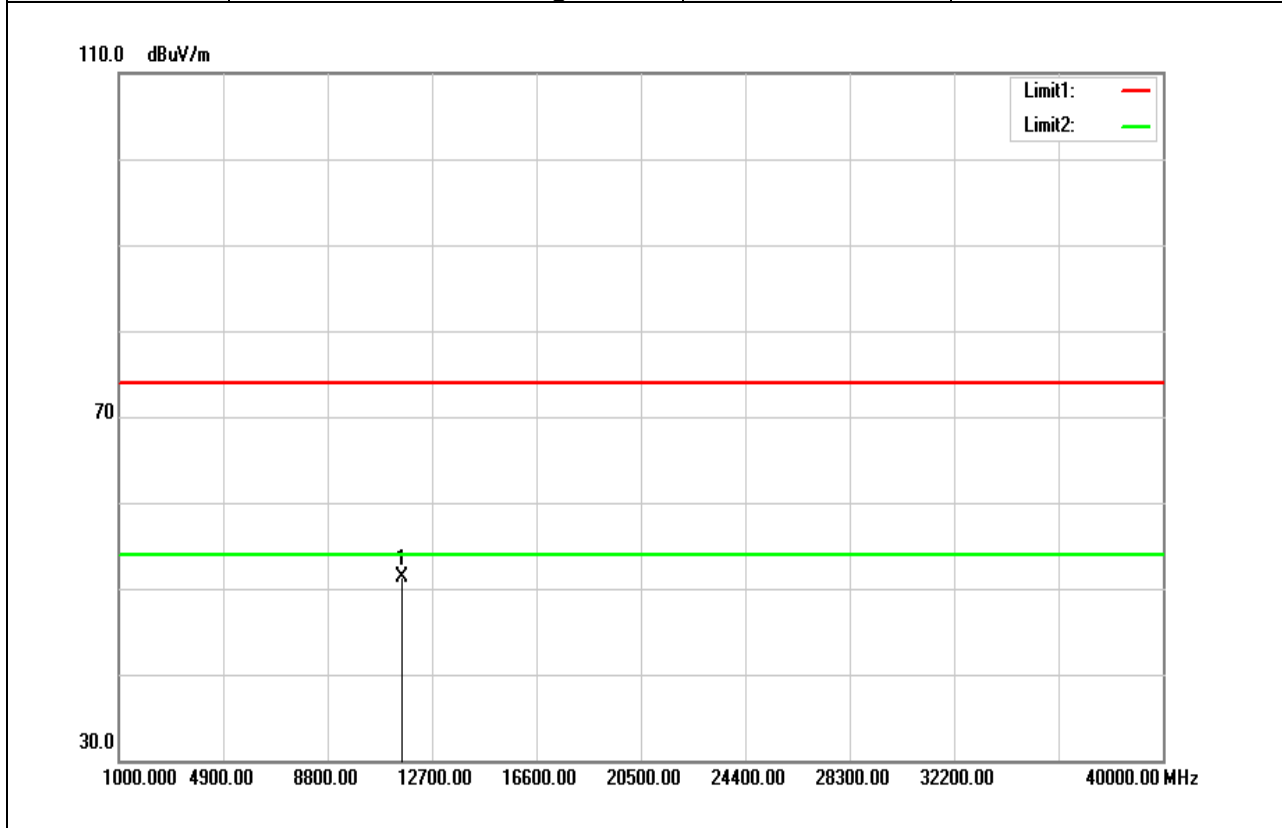

Frequency (MHz)	Reading (dBuV)	Correct Factor (dB/m)	Result (dBuV/m)	Limit (dBuV/m)	Margin (dB)	Remark
11590.000	35.23	16.00	51.23	74.00	-22.77	peak
N/A						

Remark:

1. Measuring frequencies from 1 GHz to the 10th harmonic of highest fundamental frequency.
2. For above 1GHz, the EUT peak value was under average limit, therefore the Average value compliance with the average limit

Test Mode	IEEE 802.11ac VHT80/ 5775 MHz	Temp/Hum	22(°C)/ 34%RH
Test Item	Harmonic	Test Date	July 30, 2018
Polarize	Vertical	Test Engineer	Jerry Chuang
Detector	Peak and Average		

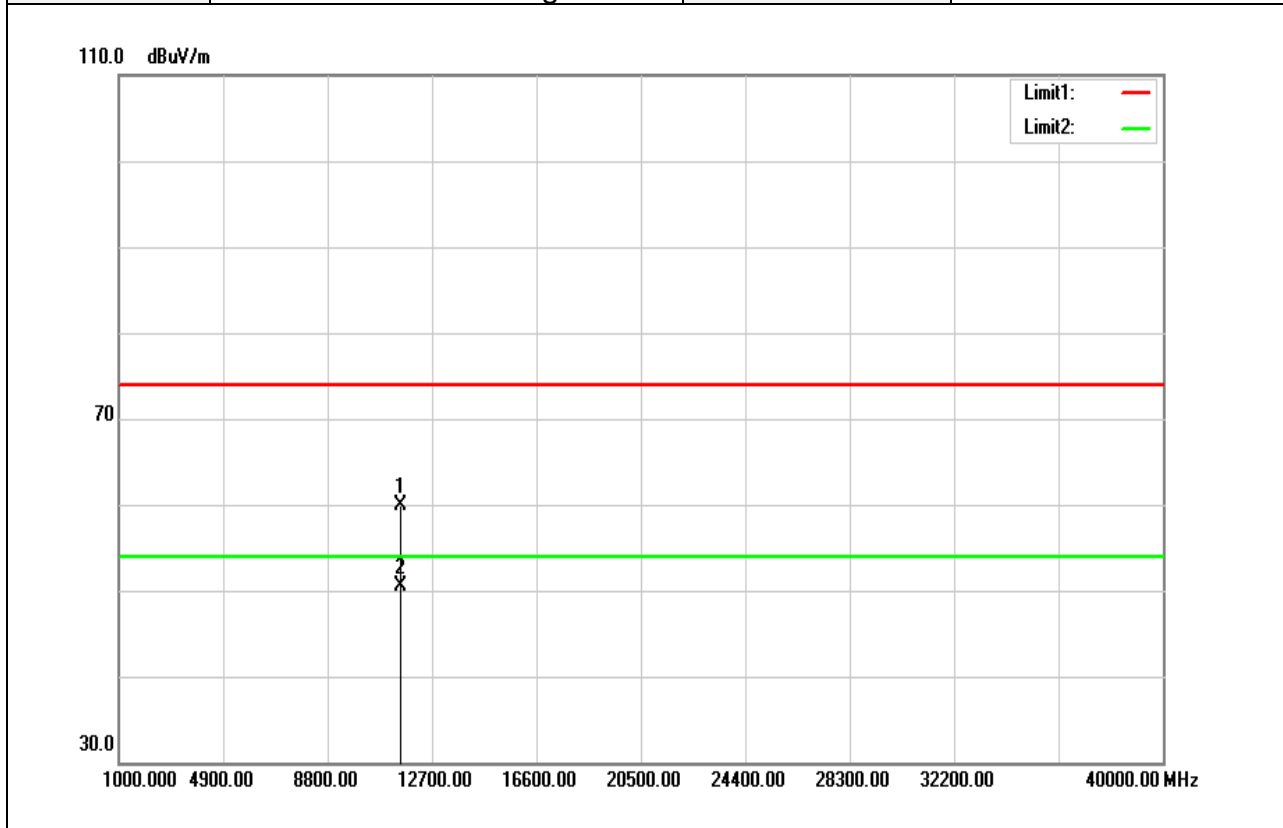

Frequency (MHz)	Reading (dBuV)	Correct Factor (dB/m)	Result (dBuV/m)	Limit (dBuV/m)	Margin (dB)	Remark
11510.000	43.82	16.08	59.90	74.00	-14.10	peak
11510.000	34.38	16.08	50.46	54.00	-3.54	AVG
N/A						

Remark:

1. Measuring frequencies from 1 GHz to the 10th harmonic of highest fundamental frequency.
2. For above 1GHz, the EUT peak value was under average limit, therefore the Average value compliance with the average limit

Test Mode	IEEE 802.11ac VHT80/ 5775 MHz	Temp/Hum	22(°C)/ 34%RH
Test Item	Harmonic	Test Date	July 30, 2018
Polarize	Horizontal	Test Engineer	Jerry Chuang
Detector	Peak and Average		

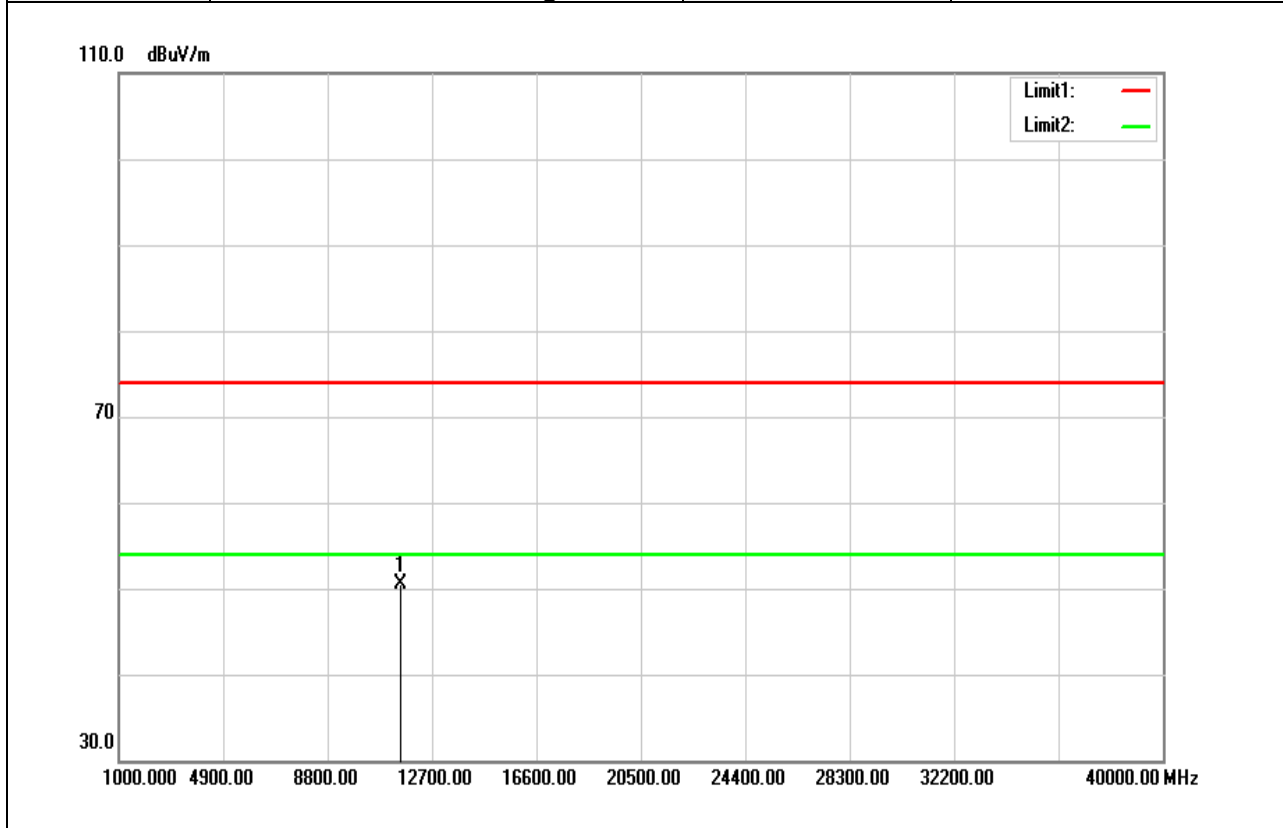

Frequency (MHz)	Reading (dBuV)	Correct Factor (dB/m)	Result (dBuV/m)	Limit (dBuV/m)	Margin (dB)	Remark
11550.000	34.37	16.04	50.41	74.00	-23.59	peak
N/A						

Remark:

1. Measuring frequencies from 1 GHz to the 10th harmonic of highest fundamental frequency.
2. For above 1GHz, the EUT peak value was under average limit, therefore the Average value compliance with the average limit

4.6 FREQUENCY STABILITY

4.6.1 Test Limit

According to §15.407(g) manufacturers of U-NII devices are responsible for ensuring frequency stability such that an emission is maintained within the band of operation under all conditions of normal operation as specified in the operational description.

4.6.2 Test Procedure

The equipment under test was connected to an external AC or DC power supply and input rated voltage. RF output was connected to a frequency counter or spectrum analyzer via feed through attenuators. The EUT was placed inside the temperature chamber. Set the spectrum analyzer RBW low enough to obtain the desired frequency resolution and measure EUT 20°C operating frequency as reference frequency. Turn EUT off and set the chamber temperature to -20°C. After the temperature stabilized for approximately 30 minutes recorded the frequency. Repeat step measure with 10°C increased per stage until the highest temperature of +50°C reached.

4.6.3 Test Setup

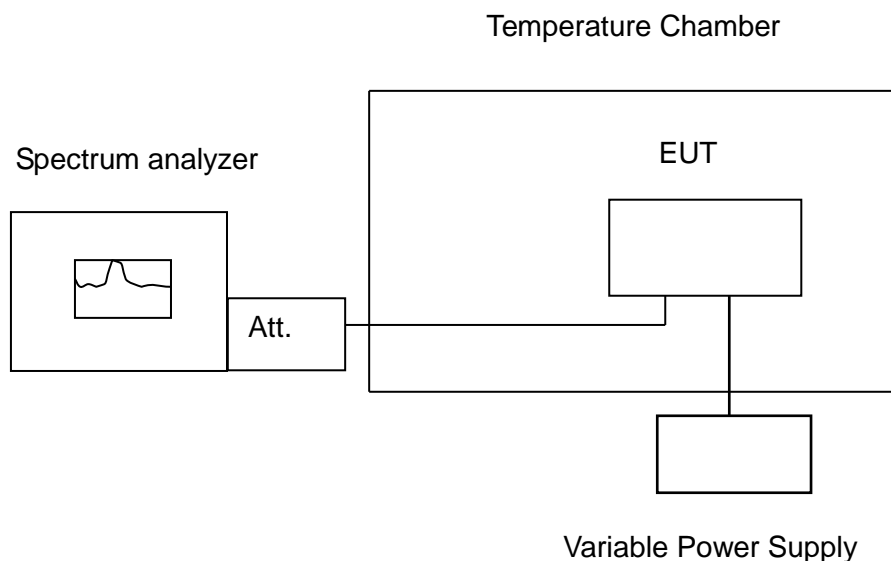

Report No.: T180627D11-RP4

4.6.4 Test Result

Temp. (°C)	Voltage (V)	Measured Frequency	5180								Result
			Time (min)								
Operating Frequency:		0 min	2 min	5 min	10 min	0 min	2 min	5 min	10 min		
50	Normal	5180.10320	5180.07641	5180.10120	5180.10090	19.9228	14.7510	19.5367	19.4788	Pass	
40	Normal	5180.09510	5180.09514	5180.09423	5180.09231	18.3591	18.3658	18.1911	17.8205	Pass	
30	Normal	5180.08123	5180.08412	5180.07641	5180.07964	15.6815	16.2394	14.7510	15.3745	Pass	
20	Normal	5180.08531	5180.07561	5179.98310	5180.06513	16.4691	14.5965	-3.2625	12.5734	Pass	
10	Normal	5180.04564	5180.08531	5180.04645	5180.03156	8.8108	16.4691	8.9672	6.0927	Pass	
0	Normal	5180.02199	5180.02564	5180.03457	5180.02000	4.2450	4.9506	6.6735	3.8610	Pass	
-10	Normal	5180.00156	5180.00321	5180.07641	5180.07910	0.3012	0.6197	14.7510	15.2703	Pass	
-20	Normal	5179.98310	5180.10090	5180.03156	5179.94532	-3.2625	19.4788	6.0927	-10.5560	Pass	
Temp. (°C)	Voltage (V)	Measured Frequency	5180								Result
			Time (min)								
Operating Frequency:		0 min	2 min	5 min	10 min	0 min	2 min	5 min	10 min		
20	Minimum	5180.085250	5180.08531	5180.05325	5180.06432	16.4575	16.4691	10.2799	12.4170	Pass	
20	Normal	5180.08531	5180.07561	5179.98310	5180.06513	16.4691	14.5965	-3.2625	12.5734	Pass	
20	Maximum	5180.084320	5180.06150	5180.06312	5180.07651	16.2780	11.8726	12.1853	14.7703	Pass	

Temp. (°C)	Voltage (V)	Measured Frequency	5745								Result
			Time (min)								
Operating Frequency:		0 min	2 min	5 min	10 min	0 min	2 min	5 min	10 min		
50	Normal	5745.10549	5745.10189	5745.10695	5745.10980	18.3619	17.7354	18.6157	19.1123	Pass	
40	Normal	5745.09784	5745.00071	5745.09212	5745.00040	17.0306	0.1238	16.0353	0.0696	Pass	
30	Normal	5745.08412	5745.08048	5745.05059	5745.07022	14.6428	14.0085	8.8057	12.2222	Pass	
20	Normal	5745.07023	5745.07319	5745.07154	5745.07945	12.2247	12.7391	12.4519	13.8296	Pass	
10	Normal	5745.05153	5745.05123	5745.05979	5745.05059	8.9697	8.9175	10.4071	8.8057	Pass	
0	Normal	5745.03486	5745.03741	5745.03312	5745.03987	6.0687	6.5117	5.7654	6.9406	Pass	
-10	Normal	5745.08412	5745.09078	5745.00923	5745.00874	14.6428	15.8016	1.6069	1.5215	Pass	
-20	Normal	5745.00040	5745.00048	5745.00071	5745.00084	0.0696	0.0833	0.1238	0.1464	Pass	
Temp. (°C)	Voltage (V)	Measured Frequency	5745								Result
			Time (min)								
Operating Frequency:		0 min	2 min	5 min	10 min	0 min	2 min	5 min	10 min		
20	Minimum	5745.06916	5745.06915	5745.06905	5745.06811	12.0376	12.0362	12.0188	11.8555	Pass	
20	Normal	5745.07023	5745.07319	5745.07154	5745.07945	12.2247	12.7391	12.4519	13.8296	Pass	
20	Maximum	5745.07123	5745.07849	5745.07278	5745.07212	12.3988	13.6625	12.6684	12.5541	Pass	

--End of Report--