

Project No.: TM-2305000172P
 Report No.: TMWK2305001496KR

FCC ID: 2AKZA-IW416
 IC: 22364-IW416

Page: 1 / 87
 Rev.: 00

RADIO TEST REPORT

FCC 47 CFR PART 15 SUBPART C

INDUSTRY CANADA RSS-247

Test Standard	FCC Part 15.247 IC RSS-247 issue 2 and IC RSS-GEN issue 5
Product name	WiFi+Bluetooth 5.2 System on Module
Brand Name	TechNexion
Model	PIXI-IW416
Test Result	Pass
Statements of Conformity	Determination of compliance is based on the results of the compliance measurement, not taking into account measurement instrumentation uncertainty.

The test Result was tested by Compliance Certification Services Inc. The test data, data evaluation, test procedures, and equipment configurations shown in this report were given in ANSI C63.10: 2013 and compliance standards.

The test results of this report relate only to the tested sample (EUT) identified in this report.

The test Report of full or partial shall not copy. Without written approval of Compliance Certification Services Inc. (Wugu Laboratory)

Approved by:



Shawn Wu
 Supervisor

Unless otherwise stated the results shown in this test report refer only to the sample(s) tested and such sample(s) are retained for 90 days only.
 除非另有說明，此報告結果僅對測試之樣品負責，同時此樣品僅保留90天。本報告未經本公司書面許可，不可部份複製。

This document is issued by the Company subject to its General Conditions of Service printed overleaf, available on request or accessible at <http://www.sgs.com.tw/Terms-and-Conditions> and, for electronic format documents, subject to Terms and Conditions for Electronic Documents at <http://www.sgs.com.tw/Terms-and-Conditions>. Attention is drawn to the limitation of liability, indemnification and jurisdiction issues defined therein. Any holder of this document is advised that information contained hereon reflects the Company's findings at the time of its intervention only and within the limits of client's instruction, if any. The Company's sole responsibility is to its Client and this document does not exonerate parties to a transaction from exercising all their rights and obligations under the transaction documents. This document cannot be reproduced, except in full, without prior written approval of the Company. Any unauthorized alteration, forgery or falsification of the content or appearance of this document is unlawful and offenders may be prosecuted to the fullest extent of the law.

Revision History

Rev.	Issue Date	Revisions	Effect Page	Revised By
00	August 7, 2023	Initial Issue	ALL	Allison Chen

Table of contents

1.	GENERAL INFORMATION	4
1.1	EUT INFORMATION	4
1.2	EUT CHANNEL INFORMATION	5
1.3	ANTENNA INFORMATION	5
1.4	MEASUREMENT UNCERTAINTY.....	6
1.5	FACILITIES AND TEST LOCATION	7
1.6	INSTRUMENT CALIBRATION	7
1.7	SUPPORT AND EUT ACCESSORIES EQUIPMENT	9
1.8	TEST METHODOLOGY AND APPLIED STANDARDS	9
2.	TEST SUMMARY	10
3.	DESCRIPTION OF TEST MODES.....	11
3.1	THE WORST MODE OF OPERATING CONDITION	11
3.2	THE WORST MODE OF MEASUREMENT	12
3.3	EUT DUTY CYCLE.....	13
4.	TEST RESULT	14
4.1	AC POWER LINE CONDUCTED EMISSION	14
4.2	6DB BANDWIDTH AND OCCUPIED BANDWIDTH (99%)	19
4.3	OUTPUT POWER MEASUREMENT	25
4.4	POWER SPECTRAL DENSITY.....	28
4.5	CONDUCTED BAND EDGE AND SPURIOUS EMISSION	32
4.6	RADIATION BANDEDGE AND SPURIOUS EMISSION	39
APPENDIX 1 - PHOTOGRAPHS OF EUT		

Report No.: TMWK2305001496KR

1. GENERAL INFORMATION

1.1 EUT INFORMATION

Applicant	TechNexion Ltd. 16F-5, No. 736, Zhongzheng Road, ZhongHe District, 23511, New Taipei City, Taiwan
Manufacturer	TechNexion Ltd. 16F-5, No. 736, Zhongzheng Road, ZhongHe District, 23511, New Taipei City, Taiwan
Equipment	WiFi+Bluetooth 5.2 System on Module
Model No.	PIXI-IW416
Model Discrepancy	N/A
Trade Name	TechNexion
Received Date	May 16, 2023
Date of Test	May 19 ~ June 27, 2023
Power Supply	Power from host system. (DC 3.3V)
HW Version	A1
SW Version	1.0

Remark:

1. For more details, please refer to the User's manual of the EUT.
2. Disclaimer: Antenna information is provided by the applicant, test results of this report are applicable to the sample EUT received.

1.2 EUT CHANNEL INFORMATION

Frequency Range	2402MHz-2480MHz
Modulation Type	GFSK for BLE 1 Mbps GFSK for BLE 2 Mbps
Number of channels	40 Channels

Remark:

Refer as ANSI C63.10: 2013 clause 5.6.1 Table 4 for test channels

Number of frequencies to be tested		
Frequency range in which device operates	Number of frequencies	Location in frequency range of operation
<input type="checkbox"/> 1 MHz or less	1	Middle
<input type="checkbox"/> 1 MHz to 10 MHz	2	1 near top and 1 near bottom
<input checked="" type="checkbox"/> More than 10 MHz	3	1 near top, 1 near middle, and 1 near bottom

1.3 ANTENNA INFORMATION

Antenna Type	<input type="checkbox"/> PCB <input checked="" type="checkbox"/> PIFA <input checked="" type="checkbox"/> Dipole <input type="checkbox"/> Coils
Antenna Gain	1. PIFA Antenna Gain: 2.5 dBi 2. Dipole Antenna Gain: 4 dBi
Brand / Model	1. PIFA Antenna: TechNexion / VM2450-25523-OOX-180 2. Dipole Antenna: TechNexion / VM2450-ASSY1005
Antenna connector	MHF

Notes:

1. The antenna(s) of the EUT are permanently attached and there are no provisions for connection to an external antenna. So the EUT complies with the requirements of §15.203 and RSS-Gen §6.8.

1.4 MEASUREMENT UNCERTAINTY

PARAMETER	UNCERTAINTY
AC Powerline Conducted Emission	± 2.213 dB
Channel Bandwidth	± 2.7 %
RF output power (Power Meter + Power sensor)	± 0.243 dB
Power Spectral density	± 2.739 dB
Conducted Bandedge	± 2.739 dB
Conducted Spurious Emission	± 2.742 dB
Radiated Emission_9kHz-30MHz	± 3.115 dB
Radiated Emission_30MHz-200MHz	± 4.071 dB
Radiated Emission_200MHz-1GHz	± 4.419 dB
Radiated Emission_1GHz-6GHz	± 5.023 dB
Radiated Emission_6GHz-18GHz	± 5.068 dB
Radiated Emission_18GHz-26GHz	± 3.349 dB
Radiated Emission_26GHz-40GHz	± 3.229 dB

Remark:

- 1.This uncertainty represents an expanded uncertainty expressed at approximately the 95% confidence level using a coverage factor of k=2
2. ISO/IEC 17025 requires that an estimate of the measurement uncertainties associated with the emissions test results be included in the report.

Report No.: TMWK2305001496KR

1.5 FACILITIES AND TEST LOCATION

All measurement facilities used to collect the measurement data are located at

AC Powerline Conducted Emission and Conducted:

No.11, Wugong 6th Rd., Wugu Dist., New Taipei City, Taiwan.

Radiated emission 9kHz to 40GHz:

No.11, Wugong 6th Rd., Wugu Dist., New Taipei City, Taiwan.

No. 12, Ln. 116, Wugong 3rd Rd., Wugu Dist., New Taipei City, Taiwan 24803

CAB identifier: TW1309

Test site	Test Engineer	Remark
AC Conduction Room	Tony Chao	-
Radiation	Czerny Lin	-
RF Conducted	David Li	-

Remark: The lab has been recognized as the FCC accredited lab. under the KDB 974614 D01 and is listed in the FCC pubic Access Link (PAL) database, FCC Registration No. :444940, the FCC Designation No.:TW1309.

1.6 INSTRUMENT CALIBRATION

RF Conducted Test Site					
Name of Equipment	Manufacturer	Model	Serial Number	Cal Date	Cal Due
Power Sensor	Anritsu	MA2411B	1911386	2022-08-08	2023-08-07
Power Sensor	Anritsu	MA2411B	1911387	2022-08-08	2023-08-07
EXA Signal Analyzer	Keysight	N9010B	MY60242460	2023-02-20	2024-02-01
Power Meter	Anritsu	ML2496A	2136002	2022-11-24	2023-11-23
Software	Radio Test Software Ver. 21 & E3-Ver: 6.11-20180413				

Remark:

1. Each piece of equipment is scheduled for calibration once a year.
2. N.C.R. = No Calibration Required.

3M 966 Chamber Test Site (966D_Radiated)					
Name of Equipment	Manufacturer	Model	Serial Number	Cal Date	Cal Due
Antenna	SHWARZBECK	VULB 9168	1277	2023-01-13	2024-01-12
Pre-Amplifier	EMCI	EMC118A45SE	980820	2022-12-23	2023-12-22
Pre-Amplifier	EMCI	EMC330N	980853	2022-12-23	2023-12-22
Coaxial Cable	EMC	EMC101G-KM-K M-9000	220407+211228+ 230205	2023-03-21	2024-03-20
Signal Generator	Agilent	N9010A	MY52220817	2023-03-09	2024-03-08
Coaxial Cable	EMC	EMCCFD400	211212+211222+ 211020	2023-03-21	2024-03-20
High Pass Filter	TITAN	T04H300018000 70S01	211215-7-1	2023-02-02	2024-02-01
Thermo-Hygro Meter	EDSDS	EDS-A49	966D1	2023-05-11	2024-05-10
Pre-Amplifier	EMCI	EMC184045SE	980872	2023-01-03	2024-01-02
Horn Antenna	RF SPIN	DRH18-E	210301A18ES	2023-02-03	2024-02-02
Horn Antenna	SHWARZBECK	BBHA 9170	1134	2022-12-30	2023-12-29
Loop Antenna	SCHWARZBECK	FMZB 1513-60	1513-60-028	2022-12-27	2023-12-26
Software	e3 V9-210616c				

AC Conducted Emissions Test Site					
Name of Equipment	Manufacturer	Model	Serial Number	Cal Date	Cal Due
EMI Test Receiver	R&S	ESCI	100064	2023-06-07	2024-06-06
Cable	EMCI	CFD300-NL	CERF	2023-06-26	2024-06-25
LISN	TESEQ	LN2-16N	22012	2023-03-08	2024-03-07
Software	EZ-EMC(CCS-3A1-CE-wugu)				

Remark:

1. Each piece of equipment is scheduled for calibration once a year.
2. N.C.R. = No Calibration Required.

1.7 SUPPORT AND EUT ACCESSORIES EQUIPMENT

EUT Accessories Equipment						
No.	Equipment	Brand	Model	Series No.	FCC ID	IC
	N/A					

Support Equipment						
No.	Equipment	Brand	Model	Series No.	FCC ID	IC
1	NB(E)	Lenovo	T460	N/A	N/A	N/A
	N/A					

1.8 TEST METHODOLOGY AND APPLIED STANDARDS

The test methodology, setups and results comply with all requirements in accordance with ANSI C63.10:2013, FCC Part 2, FCC Part 15.247, KDB 558074, RSS-247 Issue 2 and RSS-GEN Issue 5.

2. TEST SUMMARY

FCC Standard Section	IC Standard Section	Report Section	Test Item	Result
15.203	RSS-GEN 6.8	1.3	Antenna Requirement	Pass
15.207(a)	RSS-GEN 8.8	4.1	AC Conducted Emission	Pass
15.247(a)(2)	RSS-247(5.2)(a)	4.2	6 dB Bandwidth	Pass
-	RSS-GEN 6.7	4.2	Occupied Bandwidth (99%)	Pass
15.247(b)(3)	RSS-247(5.4)(d)	4.3	Output Power Measurement	Pass
15.247(e)	RSS-247(5.2)(b)	4.4	Power Spectral Density	Pass
15.247(d)	RSS-247(5.5)	4.5	Conducted Band Edge	Pass
15.247(d)	RSS-247(5.5)	4.5	Conducted Spurious Emission	Pass
15.247(d)	RSS-GEN 8.9, 8.10	4.6	Radiation Band Edge	Pass
15.247(d)	RSS-GEN 8.9, 8.10	4.6	Radiation Spurious Emission	Pass

Report No.: TMWK2305001496KR

3. DESCRIPTION OF TEST MODES

3.1 THE WORST MODE OF OPERATING CONDITION

Operation mode	BLE Mode (1Mbps) BLE Mode (2Mbps)
Test Channel Frequencies	1.Lowest Channel : 2402 MHz 2.Middle Channel : 2440 MHz 3.Highest Channel : 2480 MHz

Report No.: TMWK2305001496KR

3.2 THE WORST MODE OF MEASUREMENT

AC Power Line Conducted Emission	
Test Condition	AC Power line conducted emission for line and neutral
Power supply Mode	Mode 1: EUT power by NB. (Dipole Antenna) Mode 2: EUT power by NB. (PIFA Antenna)
Worst Mode	<input checked="" type="checkbox"/> Mode 1 <input checked="" type="checkbox"/> Mode 2 <input type="checkbox"/> Mode 3 <input type="checkbox"/> Mode 4

Radiated Emission Measurement Above 1G	
Test Condition	Radiated Emission Above 1G
Power supply Mode	Mode 1: EUT power by System. (Dipole Antenna) Mode 2: EUT power by System. (PIFA Antenna)
Worst Mode	<input checked="" type="checkbox"/> Mode 1 <input checked="" type="checkbox"/> Mode 2 <input type="checkbox"/> Mode 3 <input type="checkbox"/> Mode 4
Worst Position	<input type="checkbox"/> Placed in fixed position. <input type="checkbox"/> Placed in fixed position at X-Plane (E2-Plane) <input type="checkbox"/> Placed in fixed position at Y-Plane (E1-Plane) <input checked="" type="checkbox"/> Placed in fixed position at Z-Plane (H-Plane)

Radiated Emission Measurement Below 1G	
Test Condition	Radiated Emission Below 1G
Power supply Mode	Mode 1: EUT power by System. (Dipole Antenna) Mode 2: EUT power by System. (PIFA Antenna)
Worst Mode	<input checked="" type="checkbox"/> Mode 1 <input checked="" type="checkbox"/> Mode 2 <input type="checkbox"/> Mode 3 <input type="checkbox"/> Mode 4

Remark:

1. The worst mode was record in this test report.
2. EUT pre-scanned in three axis ,X,Y, Z and two polarity, for radiated measurement. The worst case(Z-Plane) were recorded in this report
3. AC power line conducted emission and for below 1G radiation emission were performed the EUT transmit at the highest output power channel as worse case.

Report No.: TMWK2305001496KR

3.3 EUT DUTY CYCLE

Temperature: 22.8~27.1°C
Humidity: 50~64% RH

Test date: May 19~June 19, 2023
Tested by: David Li

Duty Cycle				
Configuration	Duty Cycle (%) = Ton / (Ton+Toff)	Duty Factor (dB) =10*log (1/Duty Cycle)	1/T (kHz)	VBW setting (kHz)
BLE 1M	62.40	2.05	2.56	3.00
BLE 2M	33.60	4.74	4.76	5.00



Report No.: TMWK2305001496KR

4. TEST RESULT

4.1 AC POWER LINE CONDUCTED EMISSION

4.1.1 Test Limit

According to §15.207(a)(2), RSS-GEN section 8.8,

Frequency Range (MHz)	Limits(dB μ V)	
	Quasi-peak	Average
0.15 to 0.50	66 to 56*	56 to 46*
0.50 to 5	56	46
5 to 30	60	50

* Decreases with the logarithm of the frequency.

4.1.2 Test Procedure

Test method Refer as ANSI C63.10: 2013 clause 6.2,

1. The EUT was placed above horizontal ground plane and 0.4m above vertical ground plane
2. EUT connected to the line impedance stabilization network (LISN)
3. Receiver set RBW of 9kHz and Detector Peak, and note as quasi-peak and average.
4. Maximum procedure was performed on the six highest emissions to ensure EUT compliance.
5. Recorded Line for Neutral and Line.

4.1.3 Test Setup

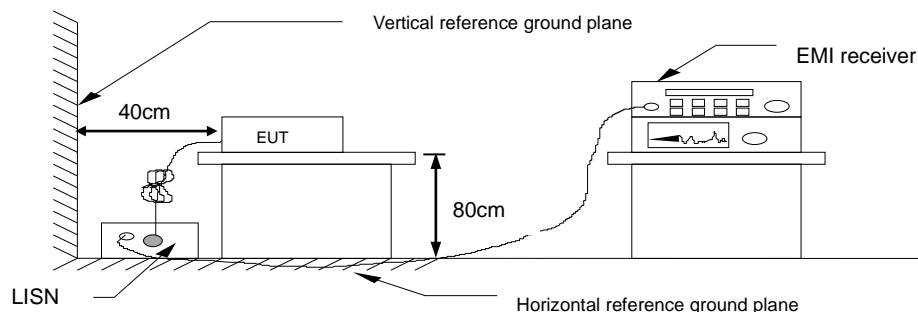

4.1.4 Test Result

Pass.

Test Data

Test Mode:	Mode 1	Temp/Hum	24.3(°C)/ 61%RH
Phase:	Line	Test Date	June 27, 2023
Test Voltage:	120Vac, 60Hz	Test Engineer	Tony Chao

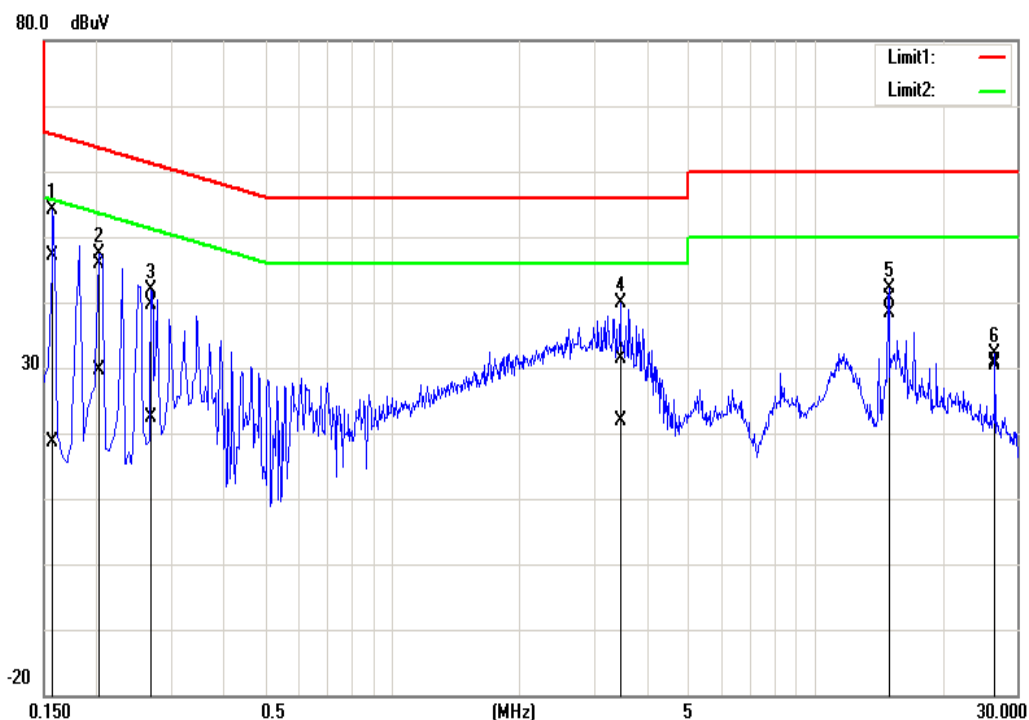

Frequency (MHz)	Quasi Peak reading (dBuV)	Average reading (d uV)	Correction factor (dB)	Quasi Peak result (dBuV)	Average result (dBuV)	Quasi Peak limit (dBuV)	Average limit (dBuV)	Quasi Peak margin (dB)	Average margin (dB)	Remark
0.1580	46.91	18.49	0.15	47.06	18.64	65.57	55.57	-18.51	-36.93	Pass
0.2020	45.72	29.44	0.15	45.87	29.59	63.53	53.53	-17.66	-23.94	Pass
0.2700	39.49	22.12	0.15	39.64	22.27	61.12	51.12	-21.48	-28.85	Pass
3.4540	31.25	21.69	0.24	31.49	21.93	56.00	46.00	-24.51	-24.07	Pass
14.9100	40.22	37.88	0.43	40.65	38.31	60.00	50.00	-19.35	-11.69	Pass
26.6220	30.27	29.74	0.61	30.88	30.35	60.00	50.00	-29.12	-19.65	Pass

Note: 1. Correction factor = LISN loss + Cable loss.

Report No.: TMWK2305001496KR

Test Mode:	Mode 1	Temp/Hum	24.3(°C)/ 61%RH
Phase:	Neutral	Test Date	June 27, 2023
Test Voltage:	120Vac, 60Hz	Test Engineer	Tony Chao

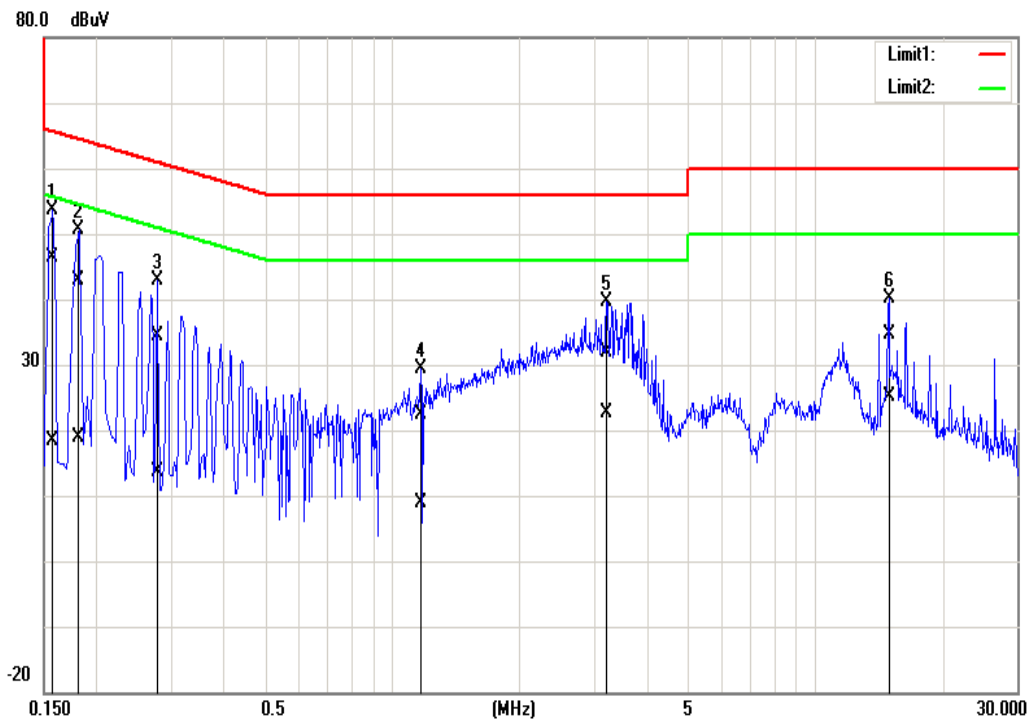

Frequency (MHz)	Quasi Peak reading (dBuV)	Average reading (dBuV)	Correction factor (dB)	Quasi Peak result (dBuV)	Average result (dBuV)	Quasi Peak limit (dBuV)	Average limit (dBuV)	Quasi Peak margin (dB)	Average margin (dB)	Remark
0.1580	46.06	18.06	0.20	46.26	18.26	65.57	55.57	-19.31	-37.31	Pass
0.1820	42.60	18.75	0.20	42.80	18.95	64.39	54.39	-21.59	-35.44	Pass
0.2780	34.13	13.56	0.19	34.32	13.75	60.88	50.88	-26.56	-37.13	Pass
1.1700	22.07	8.64	0.22	22.29	8.86	56.00	46.00	-33.71	-37.14	Pass
3.2100	31.58	22.38	0.29	31.87	22.67	56.00	46.00	-24.13	-23.33	Pass
14.9100	34.24	24.61	0.45	34.69	25.06	60.00	50.00	-25.31	-24.94	Pass

Note: 1. Correction factor = LISN loss + Cable loss.

Report No.: TMWK2305001496KR

Test Data

Test Mode:	Mode 2	Temp/Hum	24.3(°C)/ 61%RH
Phase:	Line	Test Date	June 27, 2023
Test Voltage:	120Vac, 60Hz	Test Engineer	Tony Chao

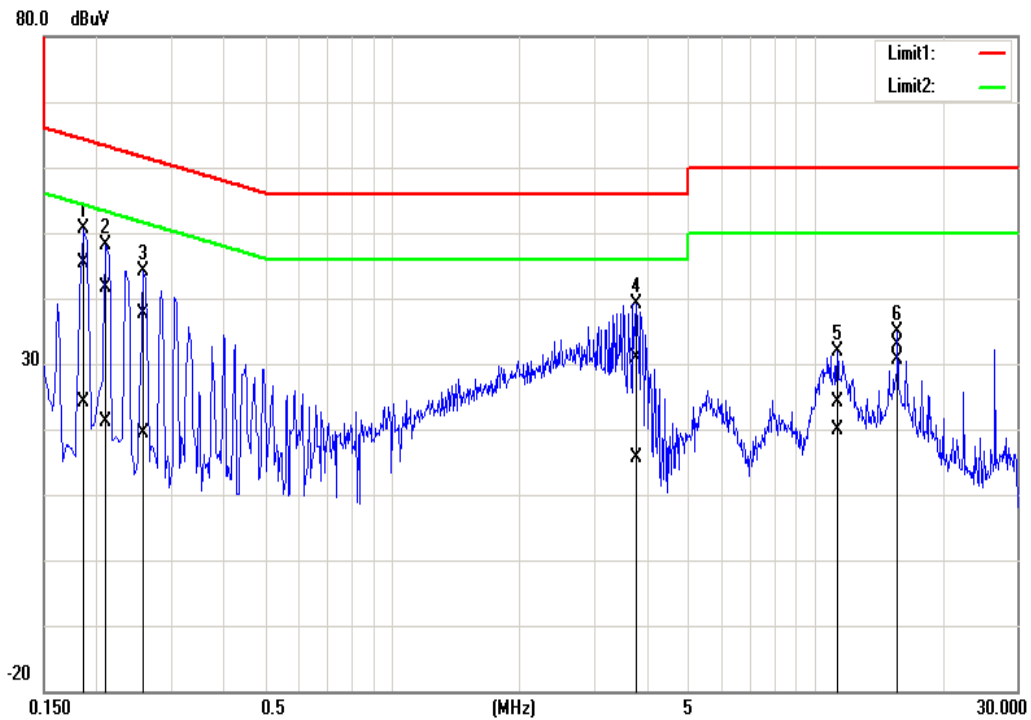

Frequency (MHz)	Quasi Peak reading (dBuV)	Average reading (d uV)	Correction factor (dB)	Quasi Peak result (dBuV)	Average result (dBuV)	Quasi Peak limit (dBuV)	Average limit (dBuV)	Quasi Peak margin (dB)	Average margin (dB)	Remark
0.1860	45.23	24.04	0.15	45.38	24.19	64.21	54.21	-18.83	-30.02	Pass
0.2100	41.51	20.92	0.15	41.66	21.07	63.21	53.21	-21.55	-32.14	Pass
0.2580	37.52	19.23	0.15	37.67	19.38	61.50	51.50	-23.83	-32.12	Pass
3.7780	30.70	15.31	0.26	30.96	15.57	56.00	46.00	-25.04	-30.43	Pass
11.2660	23.85	19.60	0.38	24.23	19.98	60.00	50.00	-35.77	-30.02	Pass
15.6660	32.40	30.17	0.45	32.85	30.62	60.00	50.00	-27.15	-19.38	Pass

Note: 1. Correction factor = LISN loss + Cable loss.

Report No.: TMWK2305001496KR

Test Mode:	Mode 2	Temp/Hum	24.3(°C)/ 61%RH
Phase:	Neutral	Test Date	June 27, 2023
Test Voltage:	120Vac, 60Hz	Test Engineer	Tony Chao

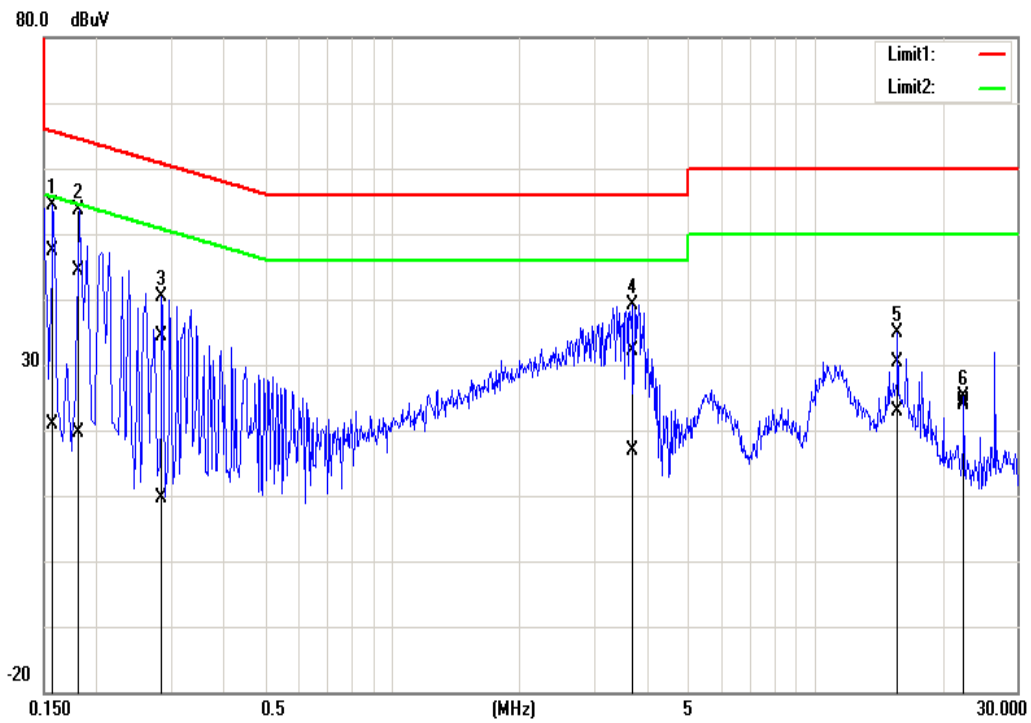

Frequency (MHz)	Quasi Peak reading (dBuV)	Average reading (dBuV)	Correction factor (dB)	Quasi Peak result (dBuV)	Average result (dBuV)	Quasi Peak limit (dBuV)	Average limit (dBuV)	Quasi Peak margin (dB)	Average margin (dB)	Remark
0.1580	47.20	20.75	0.20	47.40	20.95	65.57	55.57	-18.17	-34.62	Pass
0.1820	44.08	19.38	0.20	44.28	19.58	64.39	54.39	-20.11	-34.81	Pass
0.2860	34.08	9.36	0.19	34.27	9.55	60.64	50.64	-26.37	-41.09	Pass
3.6940	31.83	16.65	0.31	32.14	16.96	56.00	46.00	-23.86	-29.04	Pass
15.6580	29.92	22.37	0.47	30.39	22.84	60.00	50.00	-29.61	-27.16	Pass
22.5260	23.83	23.45	0.54	24.37	23.99	60.00	50.00	-35.63	-26.01	Pass

Note: 1. Correction factor = LISN loss + Cable loss.

Report No.: TMWK2305001496KR

4.2 6dB BANDWIDTH AND OCCUPIED BANDWIDTH (99%)

4.2.1 Test Limit

According to §15.247(a)(2), RSS-247 section 5.2(a),

6 dB Bandwidth :

Limit	Shall be at least 500kHz
-------	--------------------------

Occupied Bandwidth(99%) : For reporting purposes only.

4.2.2 Test Procedure

Test method Refer as ANSI C63.10: 2013,

1. The EUT RF output connected to the spectrum analyzer by RF cable.
2. Setting maximum power transmit of EUT.
3. SA set RBW =100KHz, VBW = 300KHz and Detector = Peak, to measurement 6dB Bandwidth.
4. SA set RBW = 1% ~ 5% OBW, VBW = three times the RBW and Detector = Peak, to measurement 99% Bandwidth.
5. Measure and record the result of 6 dB Bandwidth and 99% Bandwidth. in the test report.

4.2.3 Test Setup

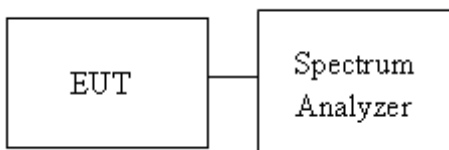

Report No.: TMWK2305001496KR

4.2.4 Test Result

Temperature: 22.8~27.1°C

Test date: May 19~June 19, 2023

Humidity: 50~64% RH

Tested by: David Li

Test mode: BLE-1Mbps mode / 2402-2480 MHz				
Channel	Frequency (MHz)	OBW (99%) (MHz)	6dB BW (kHz)	6dB limit (kHz)
Low	2402	1.0236	0.6908	≥500
Mid	2440	1.0247	0.6913	
High	2480	1.0248	0.6933	

Test mode: BLE-2Mbps mode / 2402-2480 MHz				
Channel	Frequency (MHz)	OBW (99%) (MHz)	6dB BW (kHz)	6dB limit (kHz)
Low	2402	2.0332	1.18	≥500
Mid	2440	2.0333	1.18	
High	2480	2.0347	1.180	

Report No.: TMWK2305001496KR

Test Data (6dB BANDWIDTH)

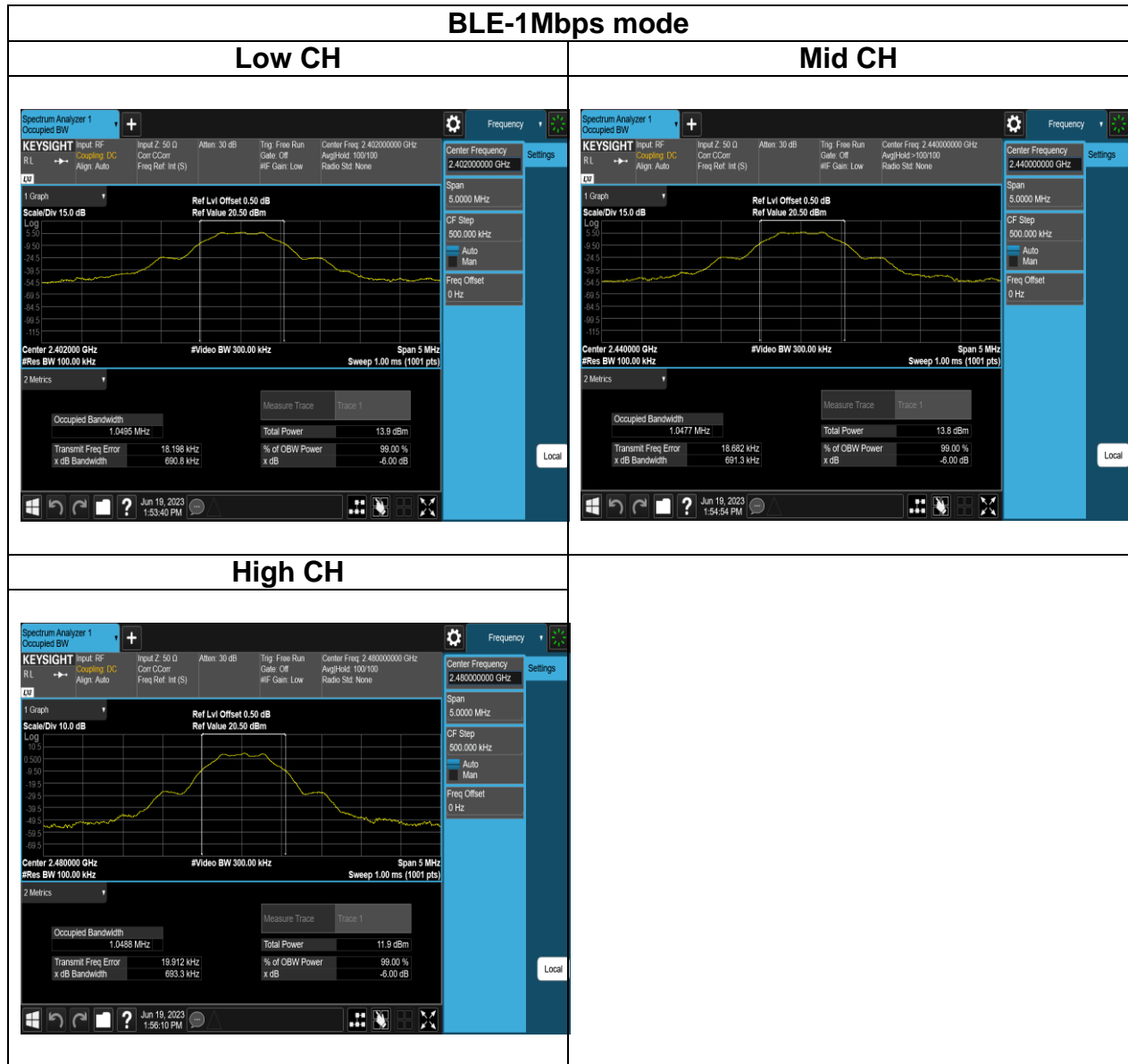

Report No.: TMWK2305001496KR

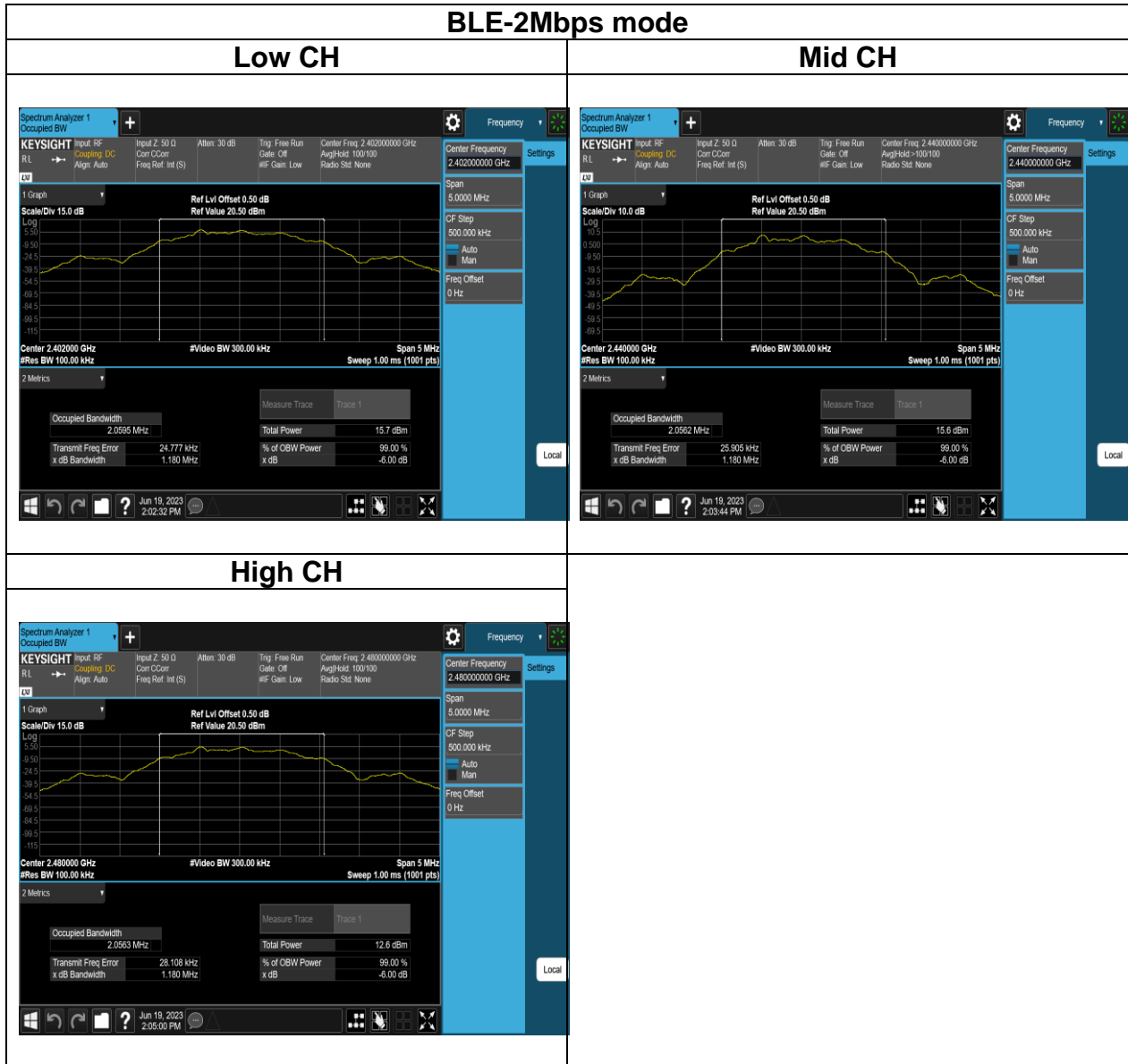

Report No.: TMWK2305001496KR

Test Data (BANDWIDTH 99%)

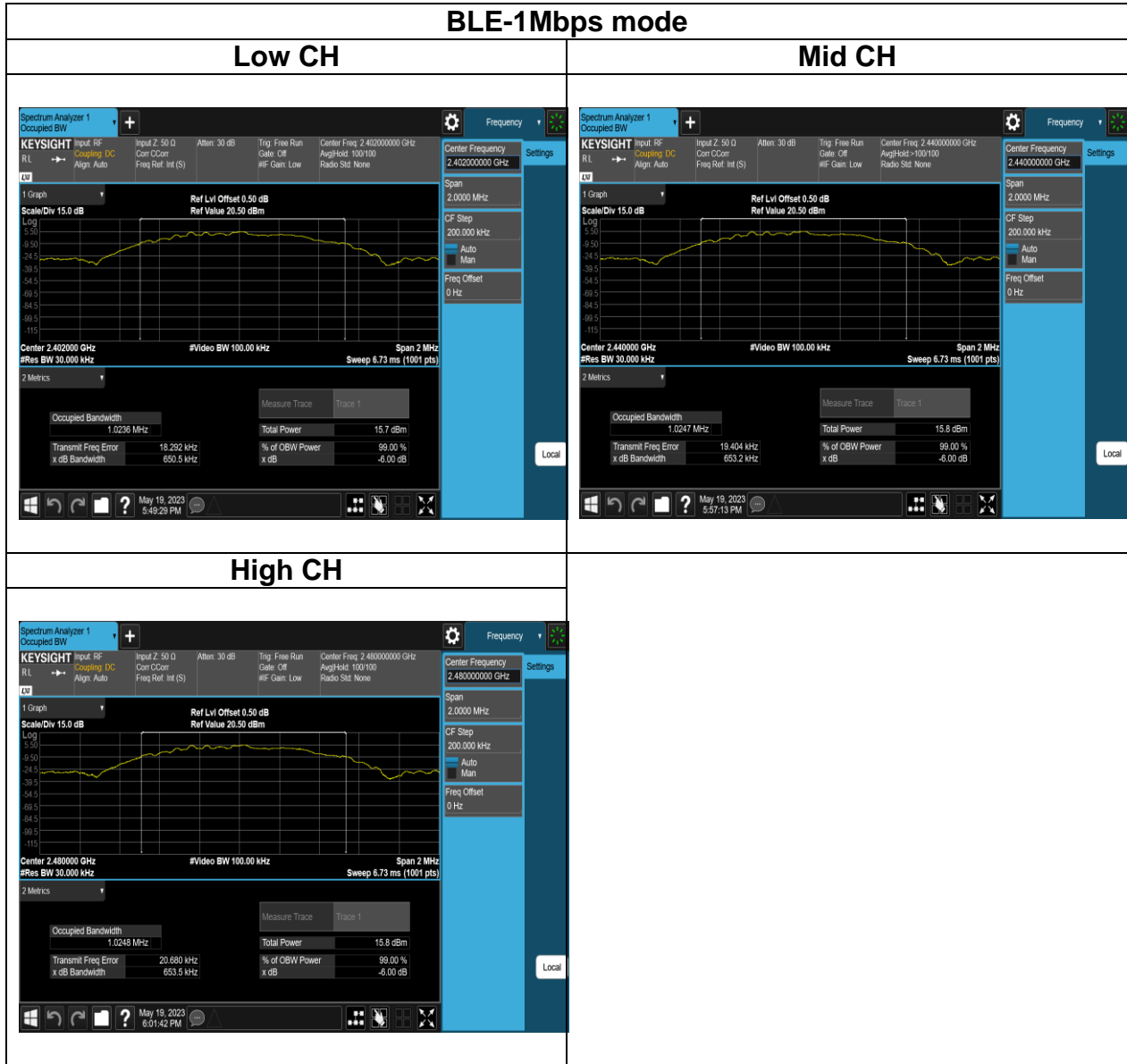

Report No.: TMWK2305001496KR

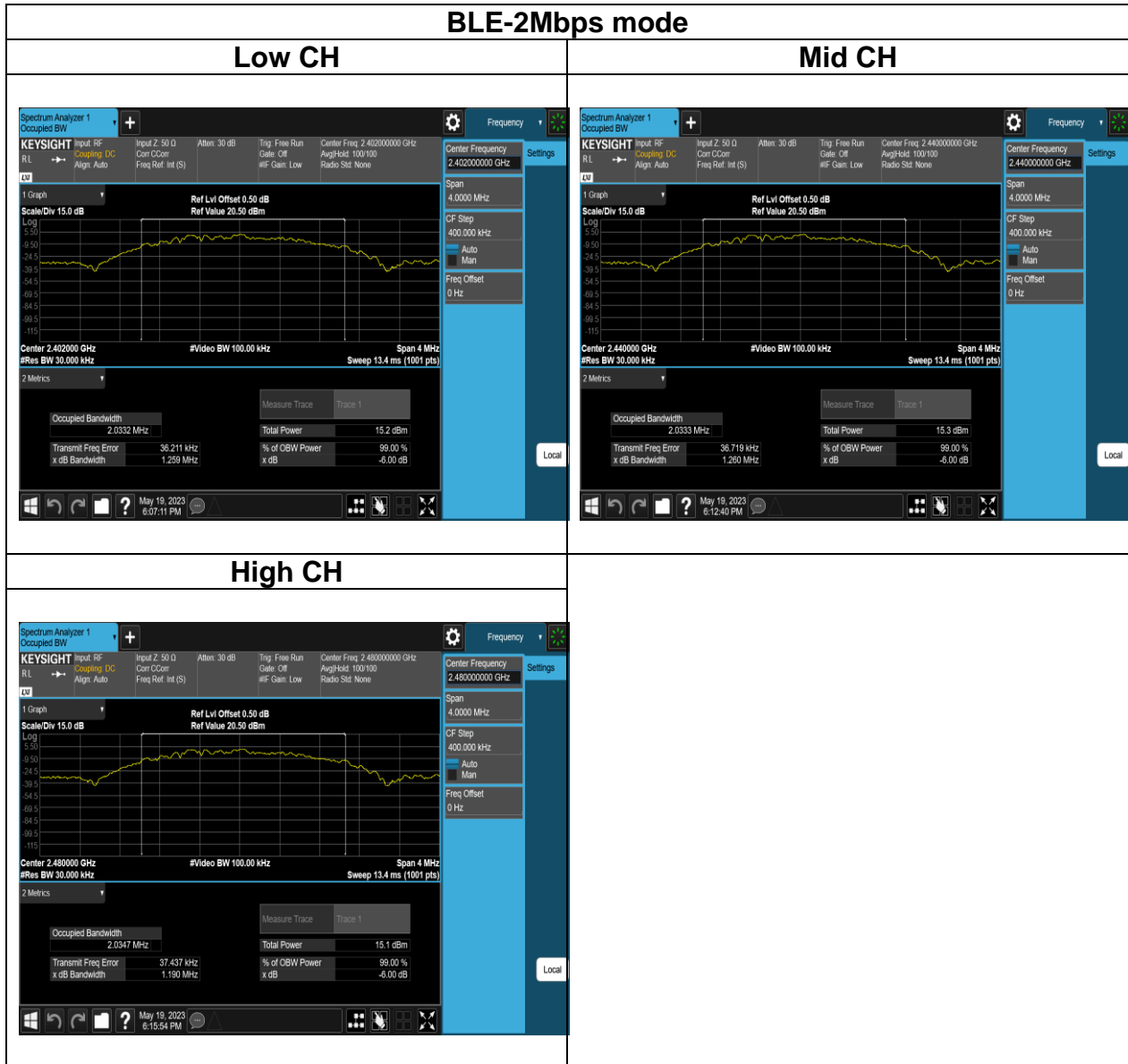

Report No.: TMWK2305001496KR

4.3 OUTPUT POWER MEASUREMENT

4.3.1 Test Limit

According to §15.247(b)(3), RSS-247 section 5.4(d)

Peak output power :

FCC

For systems using digital modulation in the 902-928 MHz, 2400-2483.5 MHz, and 5725-5850 MHz bands: 1 Watt. As an alternative to a peak power measurement, compliance with the 1 Watt limit can be based on a measurement of the maximum conducted output power.

IC

For DTSs employing digital modulation techniques operating in the bands 902-928 MHz and 2400-2483.5 MHz, the maximum peak conducted output power shall not exceed 1 W. The e.i.r.p. shall not exceed 4 W, except as provided in section 5.4(e).

Limit	<input checked="" type="checkbox"/> Antenna not exceed 6 dBi : 30dBm <input type="checkbox"/> Antenna with DG greater than 6 dBi [Limit = 30 – (DG – 6)] <input type="checkbox"/> Point-to-point operation
-------	---

Average output power : For reporting purposes only.

4.3.2 Test Procedure

Test method Refer as ANSI C63.10:2013.

1. The EUT RF output connected to the power meter by RF cable.
2. Setting maximum power transmit of EUT.
3. The path loss was compensated to the results for each measurement.
4. Measure and record the result of Peak output power and Average output power. in the test report.

4.3.3 Test Setup

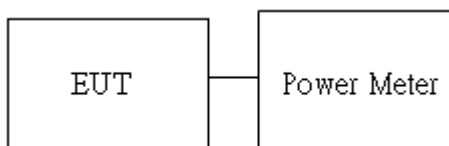

4.3.4 Test Result

Temperature: 22.8~27.1°C

Test date: May 19~June 19, 2023

Humidity: 50~64% RH

Tested by: David Li

Peak output power :

BLE 1M mode:				
CH	Frequency (MHz)	Power set	Peak Power Output (dBm)	Required Limit (dBm)
Low	2402	9	7.40	30
Mid	2440	9	7.26	30
High	2480	7	5.28	30

BLE 2M mode:				
CH	Frequency (MHz)	Power set	Peak Power Output (dBm)	Required Limit (dBm)
Low	2402	10	8.41	30
Mid	2440	10	8.31	30
High	2480	7	5.27	30

Average output power :

BLE 1M mode:				
CH	Frequency (MHz)	Power set	Average Power Output (dBm)	Required Limit (dBm)
Low	2402	9	7.30	30
Mid	2440	9	7.22	30
High	2480	7	5.26	30

BLE 2M mode:				
CH	Frequency (MHz)	Power set	Average Power Output (dBm)	Required Limit (dBm)
Low	2402	10	8.27	30
Mid	2440	10	8.28	30
High	2480	7	5.02	30

EIRP :

BLE 1M mode:						
CH	Frequency (MHz)	Power set	Avg. Output Power (dBm)	Antenna Gain (dBi)	EIRP (dBm)	Limit
Low	2402	9	7.30	4.00	11.30	4W= 36 dBm
Mid	2440	9	7.22	4.00	11.22	4W= 36 dBm
High	2480	7	5.26	4.00	9.26	4W= 36 dBm

BLE 1M mode:						
CH	Frequency (MHz)	Power set	Avg. Output Power (dBm)	Antenna Gain (dBi)	EIRP (dBm)	Limit
Low	2402	10	8.27	4.00	12.27	4W= 36 dBm
Mid	2440	10	8.28	4.00	12.28	4W= 36 dBm
High	2480	7	5.02	4.00	9.02	4W= 36 dBm

Report No.: TMWK2305001496KR

4.4 POWER SPECTRAL DENSITY

4.4.1 Test Limit

According to §15.247(e), RSS-247 section 5.2(b)

For digitally modulated systems, the power spectral density conducted from the intentional radiator to the antenna shall not be greater than 8 dBm in any 3 kHz band during any time interval of continuous transmission.

Limit	<input checked="" type="checkbox"/> Antenna not exceed 6 dBi : 8dBm <input type="checkbox"/> Antenna with DG greater than 6 dBi [Limit = 8 – (DG – 6)] <input type="checkbox"/> Point-to-point operation :
-------	---

4.4.2 Test Procedure

Test method Refer as ANSI C63.10:2013.

1. The EUT RF output connected to the spectrum analyzer by RF cable.
2. Setting maximum power transmit of EUT
3. SA set RBW = 3kHz, VBW = 10kHz, Span = 1.5 times DTS Bandwidth (6 dB BW), Detector = Peak, Sweep Time = Auto and Trace = Max hold.
4. The path loss and Duty Factor were compensated to the results for each measurement by SA.
5. Mark the maximum level.
6. Measure and record the result of power spectral density. in the test report.

4.4.3 Test Setup



Report No.: TMWK2305001496KR

4.4.4 Test Result

Temperature: 22.8~27.1°C

Test date: May 19~June 19, 2023

Humidity: 50~64% RH

Tested by: David Li

BLE 1M mode			
Frequency (MHz)	RF Power Density (dBm/3kHz)	Maximum Limit (dBm/3kHz)	Result
2402	-7.92	8	PASS
2440	-8.10	8	PASS
2480	-10.15	8	PASS

BLE 2M mode			
Frequency (MHz)	RF Power Density (dBm/3kHz)	Maximum Limit (dBm/3kHz)	Result
2402	-9.98	8	PASS
2440	-10.07	8	PASS
2480	-13.19	8	PASS

Report No.: TMWK2305001496KR

Test Data

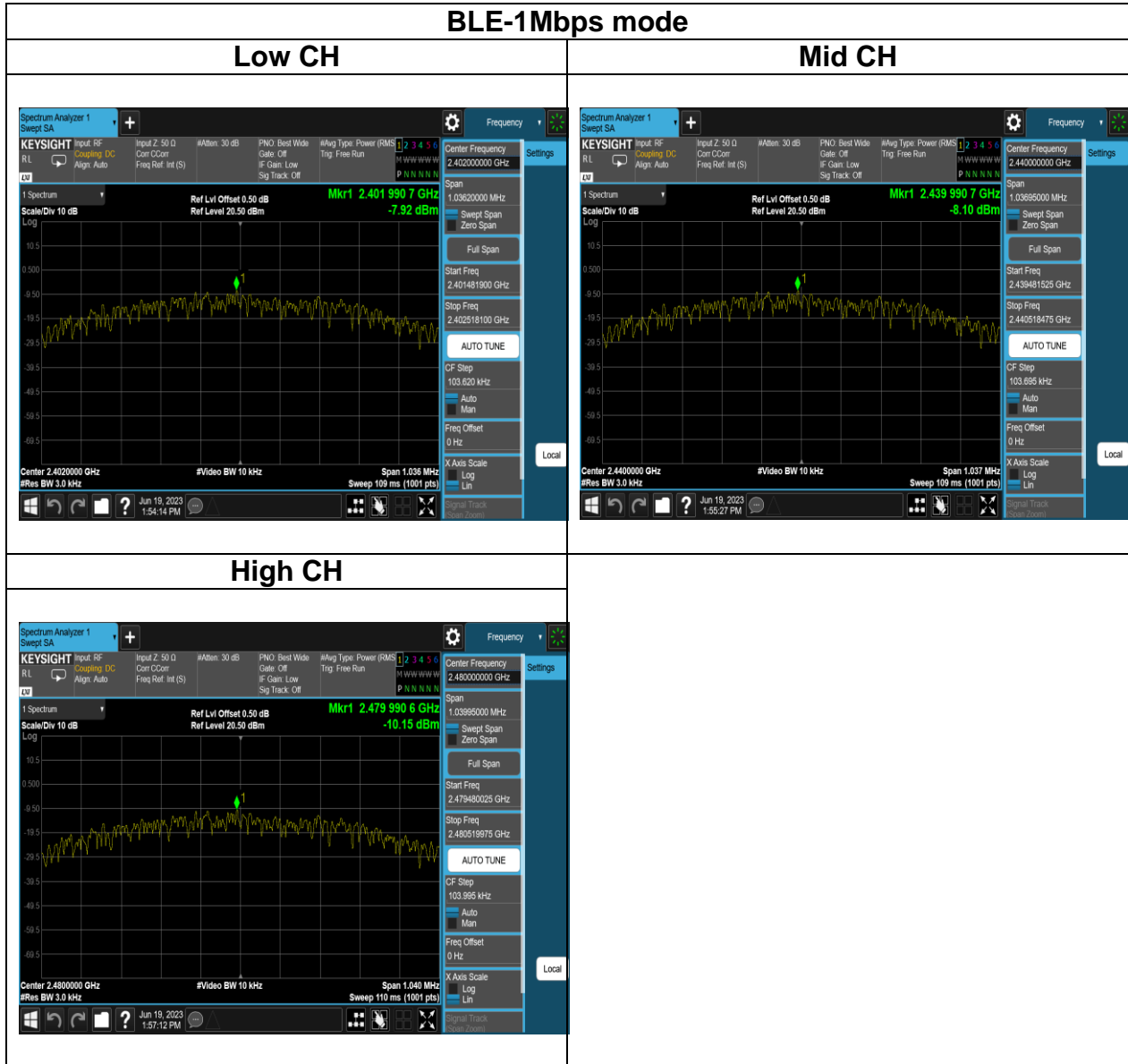

Report No.: TMWK2305001496KR

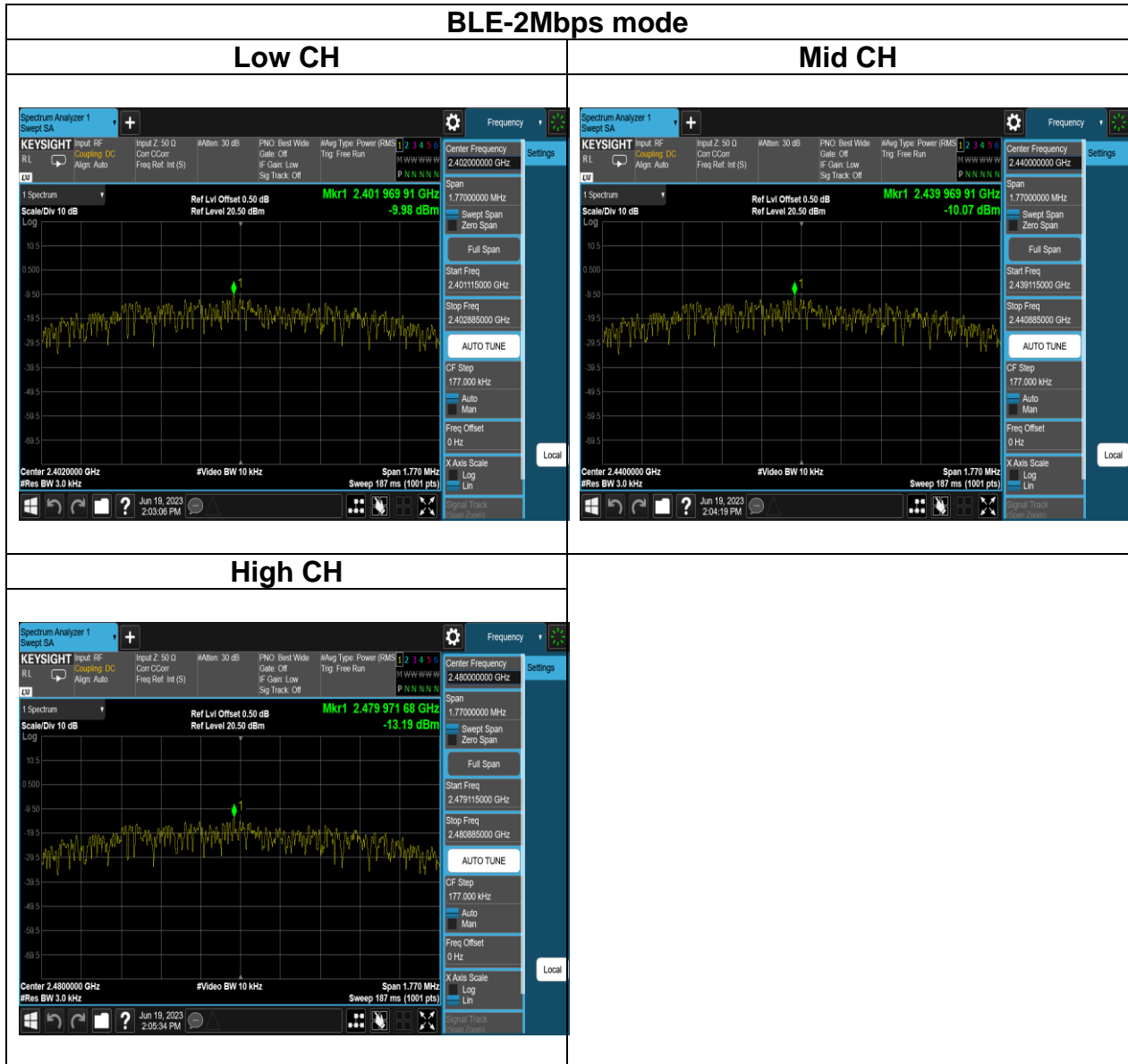

Report No.: TMWK2305001496KR

4.5 CONDUCTED BAND EDGE AND SPURIOUS EMISSION

4.5.1 Test Limit

According to §15.247(d), RSS-247 section 5.5

FCC: In any 100 kHz bandwidth outside the authorized frequency band,

Non-restricted bands shall be attenuated at least 20 dB/30 dB relative to the maximum PSD level in 100 kHz by RF conducted or a radiated measurement which fall in the restricted bands, as defined in §15.205(a), must also comply with the radiated emission limits specified in §15.209(a).

IC: In any 100 kHz bandwidth outside the frequency band in which the spread spectrum or digitally modulated device is operating, the RF power that is produced shall be at least 20 dB below that in the 100 kHz bandwidth within the band that contains the highest level of the desired power, based on either an RF conducted or a radiated measurement, provided that the transmitter demonstrates compliance with the peak conducted power limits. If the transmitter complies with the conducted power limits based on the use of root-mean-square averaging over a time interval, as permitted under section 5.4(d), the attenuation required shall be 30 dB instead of 20 dB. Attenuation below the general field strength limits specified in RSS-Gen is not required.

4.5.2 Test Procedure

Test method Refer as ANSI C63.10:2013.

1. EUT RF output port connected to the SA by RF cable, and the path loss was compensated to result.
2. SA setting, RBW=100kHz, VBW=300kHz, Detector=Peak, Trace mode = max hold, SWT = Auto.
3. In any 100 kHz bandwidth outside the authorized frequency band, shall be attenuated at least 20 dB relative to the maximum in-band peak PSD level in 100 kHz when conducted power procedure is used. If the transmitter complies with the conducted power limits based on the use of RMS averaging over a time interval, the attenuation required under this paragraph shall be 30 dB instead of 20 dB.

4.5.3 Test Setup

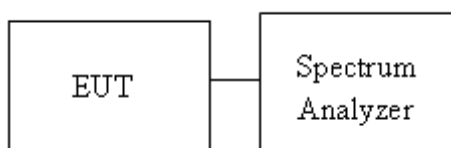

Report No.: TMWK2305001496KR

4.5.4 Test Result

Test Data

Temperature: 22.8~27.1°C

Test date: May 19~June 19, 2023

Humidity: 50~64% RH

Tested by: David Li

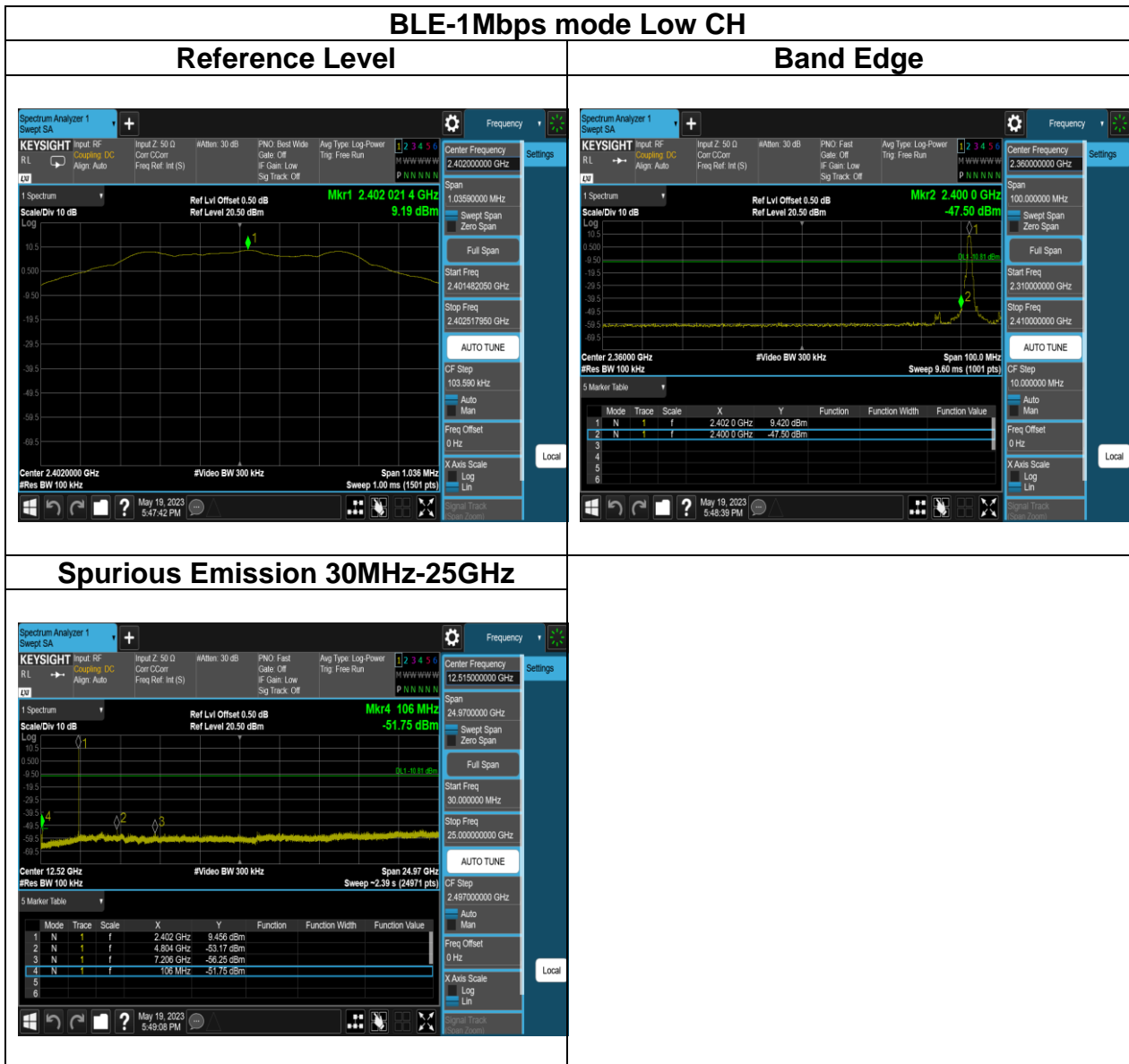

Report No.: TMWK2305001496KR

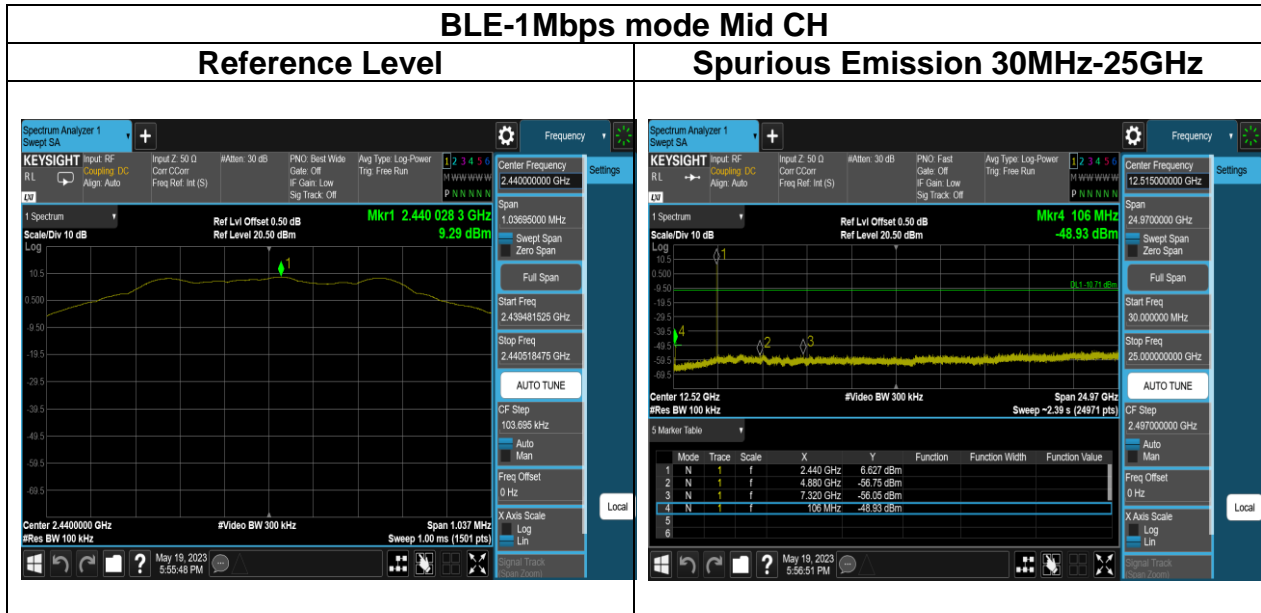

Report No.: TMWK2305001496KR

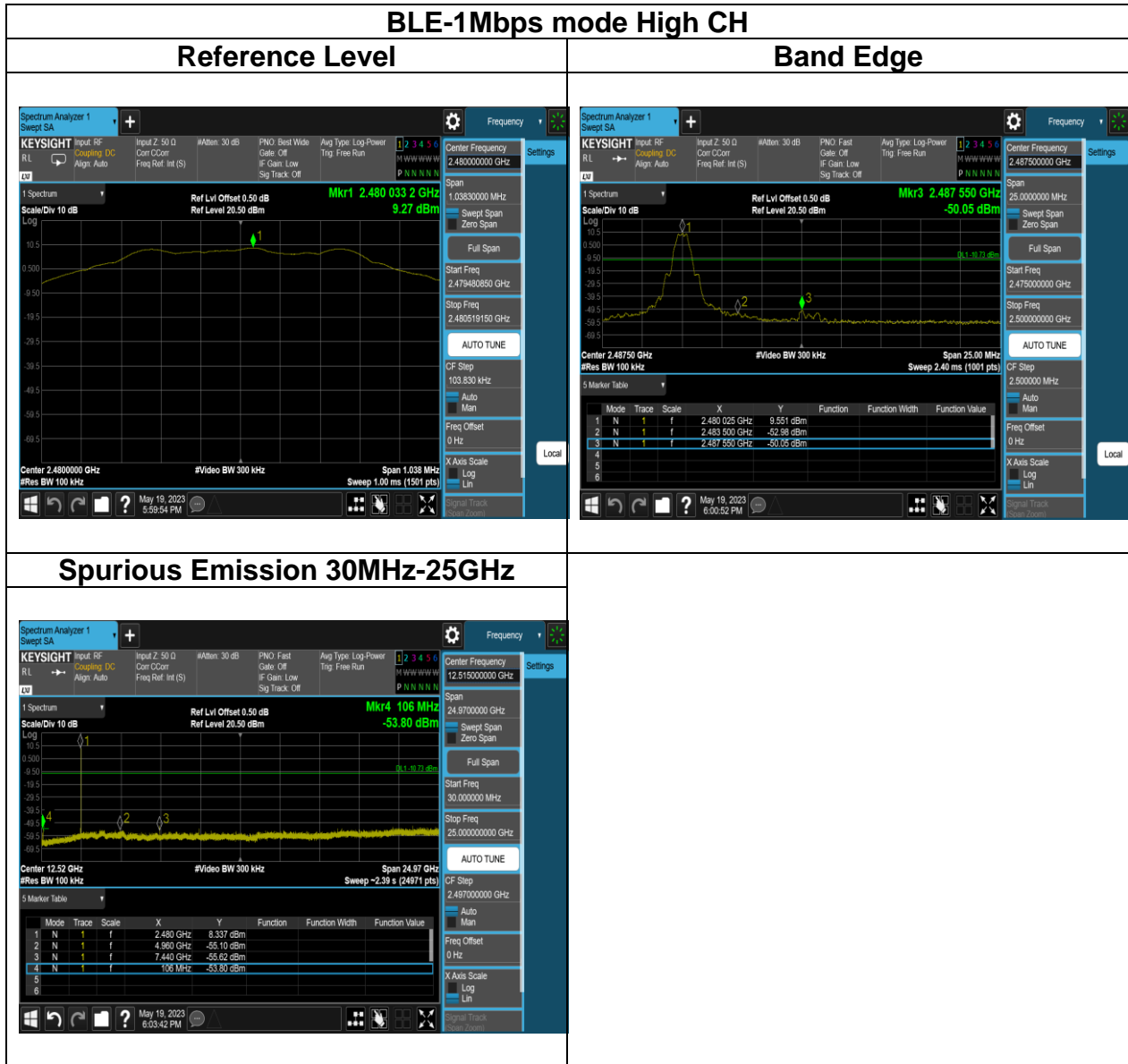

Report No.: TMWK2305001496KR

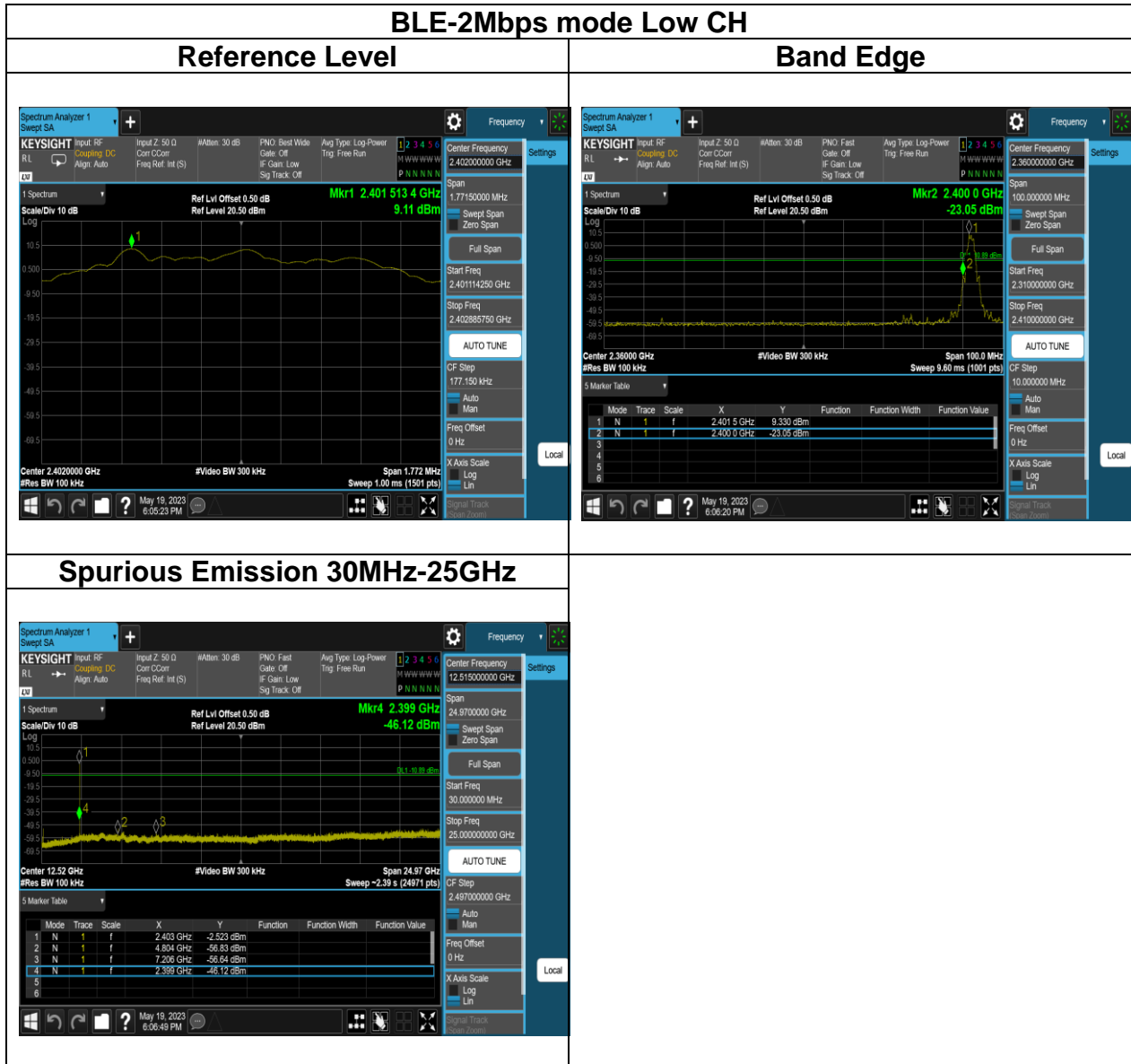

Report No.: TMWK2305001496KR

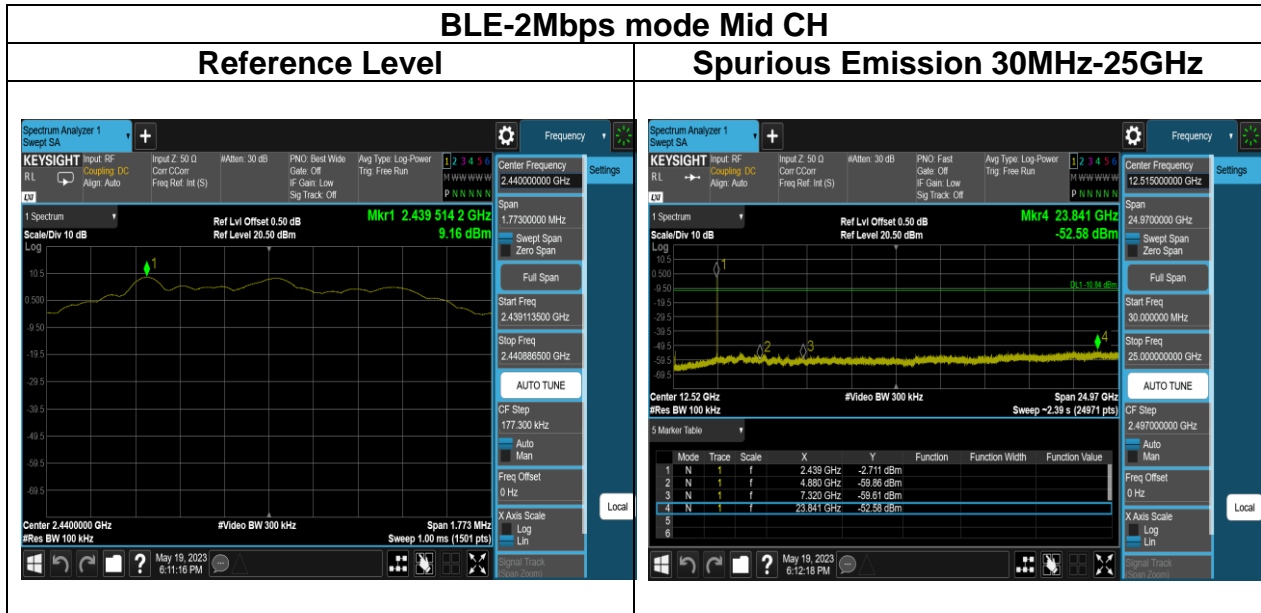

Report No.: TMWK2305001496KR

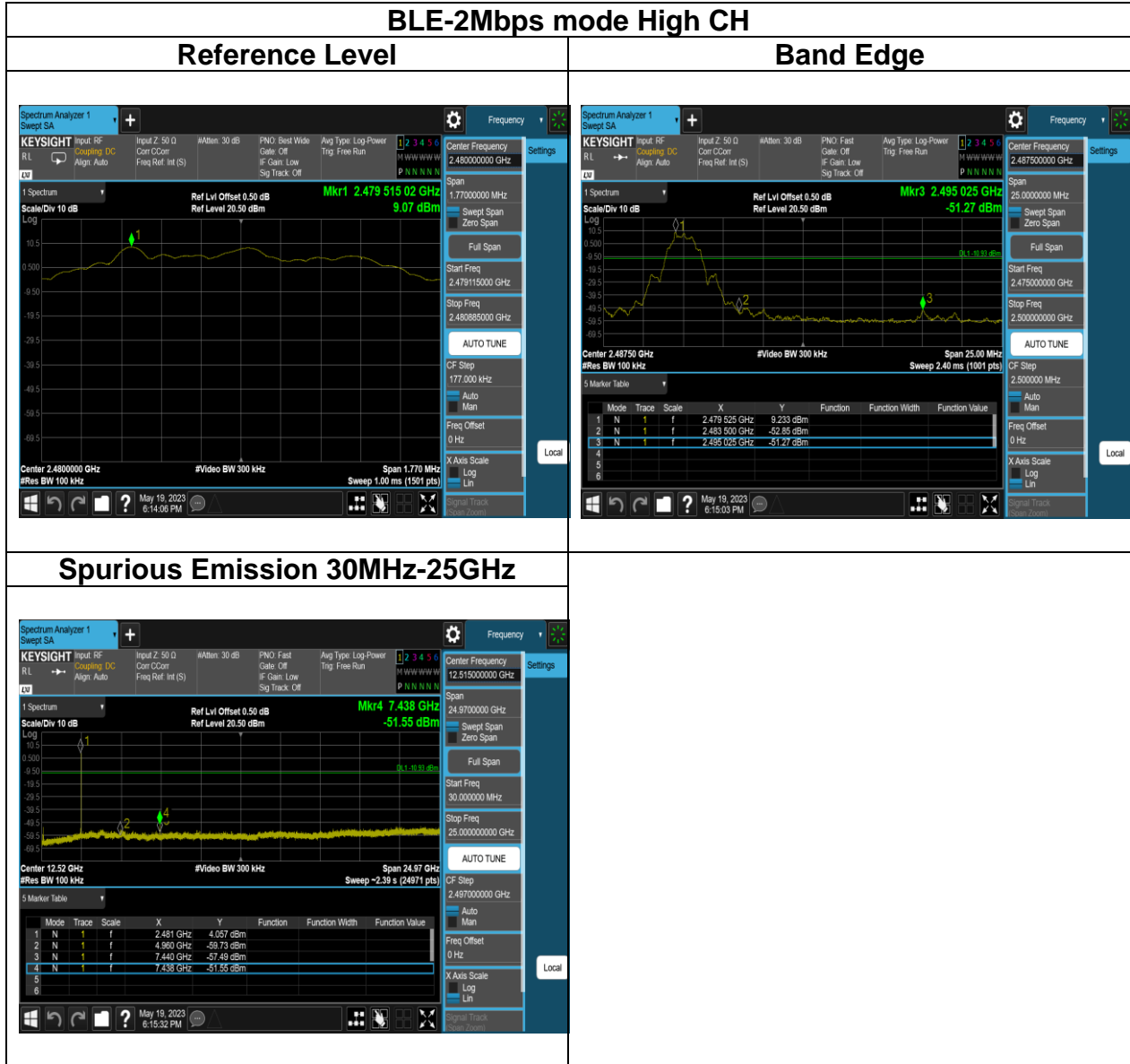

Report No.: TMWK2305001496KR

4.6 RADIATION BANDEDGE AND SPURIOUS EMISSION

4.6.1 Test Limit

FCC according to §15.247(d), §15.209 and §15.205,

IC according to RSS-247 section 5.5, RSS-Gen, Section 8.9 and 8.10

In any 100 kHz bandwidth outside the authorized frequency band, all harmonic and spurious must be least 20 dB below the highest emission level with the authorized frequency band. Radiation emission which fall in the restricted bands must also follow the FCC section 15.209 as below limit in table.

Below 30 MHz

Frequency	Field Strength (microvolts/m)	Magnetic H-Field (microamperes/m)	Measurement Distance (metres)
9-490 kHz	2,400/F (F in kHz)	2,400/F (F in kHz)	300
490-1,705 kHz	24,000/F (F in kHz)	24,000/F (F in kHz)	30
1.705-30 MHz	30	N/A	30

Above 30 MHz

Frequency (MHz)	Field Strength microvolts/m at 3 metres (watts, e.i.r.p.)	
	Transmitters	Receivers
30-88	100 (3 nW)	100 (3 nW)
88-216	150 (6.8 nW)	150 (6.8 nW)
216-960	200 (12 nW)	200 (12 nW)
Above 960	500 (75 nW)	500 (75 nW)

Remark:

Although these tests were performed other than open area test site, adequate comparison measurements were confirmed against 30 m open are test site. Therefore sufficient tests were made to demonstrate that the alternative site produces results that correlate with the ones of tests made in an open field based on KDB 414788.

RSS-Gen Table 3 and Table 5 – General Field Strength Limits for Transmitters and Receivers at Frequencies Above 30 MHz (Note)

Frequency (MHz)	Field Strength microvolts/m at 3 metres (watts, e.i.r.p.)	
	Transmitters	Receivers
30-88	100 (3 nW)	100 (3 nW)
88-216	150 (6.8 nW)	150 (6.8 nW)
216-960	200 (12 nW)	200 (12 nW)
Above 960	500 (75 nW)	500 (75 nW)

Note: Measurements for compliance with the limits in table 3 may be performed at distances other than 3 metres, in accordance with Section 6.6.

RSS-Gen Table 6: General Field Strength Limits for Transmitters at Frequencies Below 30 MHz (Transmit)

Frequency	Magnetic field strength (H-Field) (µA/m)	Measurement Distance (m)
9-490 kHz ^{Note}	6.37/F (F in kHz)	300
490-1,705 kHz	63.7/F (F in kHz)	30
1.705-30 MHz	0.08	30

Note: The emission limits for the ranges 9-90 kHz and 110-490 kHz are based on measurements employing a linear average detector.

Report No.: TMWK2305001496KR

4.6.2 Test Procedure

Test method Refer as ANSI C63.10:2013.

1. The EUT is placed on a turntable, Above 1 GHz is 1.5m and below 1 GHz is 0.8m above ground plane. The EUT Configured un accordance with ANSI C63.10: 2013, and the EUT set in a continuous mode.
2. The turntable shall be rotated for 360 degrees to determine the position of maximum emission level. And EUT is set 3m away from the receiving antenna, which is scanned from 1m to 4m above the ground plane to find out the highest emissions. Measurement are made polarized in both the vertical and the horizontal positions with antenna.
3. Span shall wide enough to full capture the emission measured. The SA from 9KHz to 26.5GHz set to the low, Mid and High channels with the EUT transmit.

Remark:

1. Although these tests were performed other than open area test site, adequate comparison measurements were confirmed against 30 m open are test site. Therefore sufficient tests were made to demonstrate that the alternative site produces results that correlate with the ones of tests made in an open field based on KDB 414788.
2. No emission found between lowest internal used/generated frequency to 30MHz (9kHz~30MHz).
3. The SA setting following :
 - (1) Below 1G : RBW = 100kHz, VBW \geq 3 RBW, Sweep = Auto, Detector = Peak, Trace = Max hold.
 - (2) Above 1G :
 - (2.1) For Peak measurement : RBW = 1MHz, VBW \geq 3 RBW, Sweep = Auto, Detector = Peak, Trace = Max hold.
 - (2.2) For Average measurement : RBW = 1MHz, VBW
·If Duty Cycle \geq 98%, VBW=10Hz.
·If Duty Cycle < 98%, VBW=1/T.

4. Data result

Actual FS=Spectrum Reading Level + Factor

Margin=Actual FS- Limit

4.6.3 Test Setup

9kHz ~ 30MHz

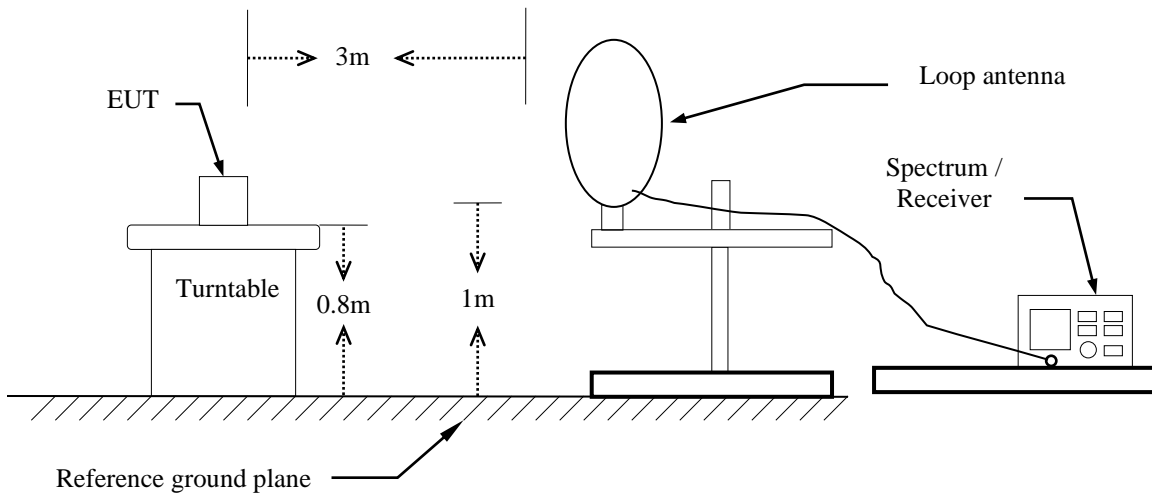

30MHz ~ 1GHz

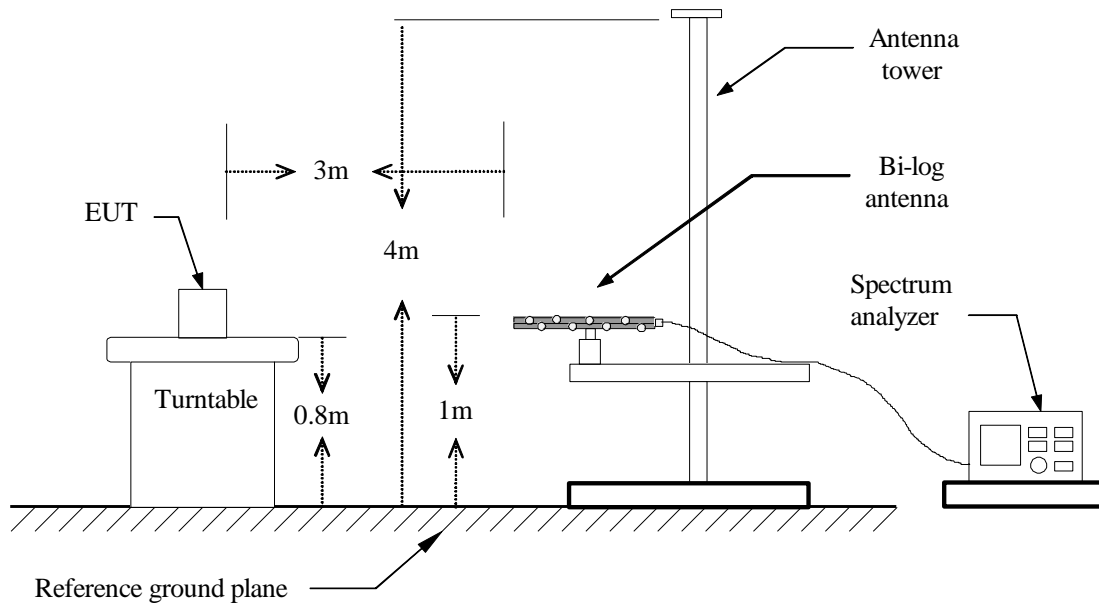

Above 1 GHz

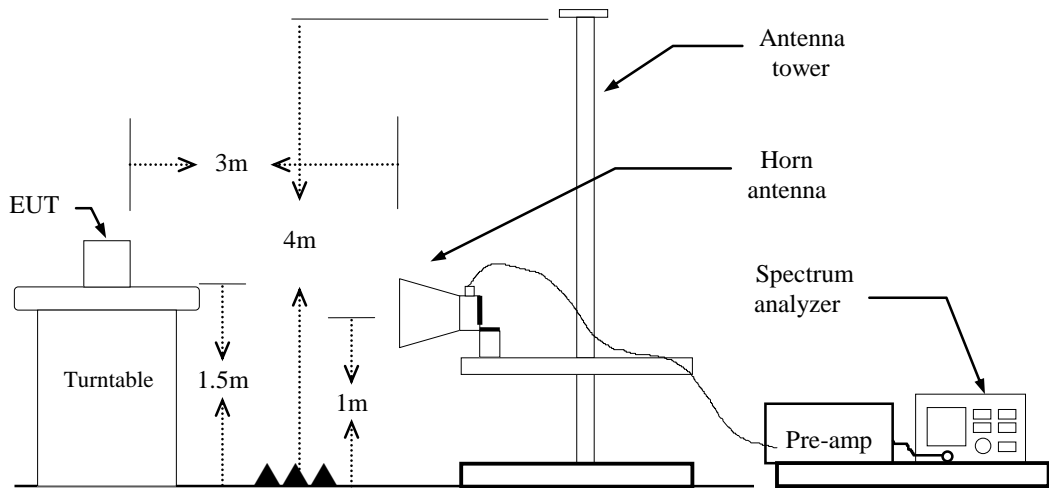

Report No.: TMWK2305001496KR

4.6.4 Test Result

Band Edge Test Data

Test Mode: Mode 1 (Dipole Antenna)

Test Mode:	BLE-1Mbps Low CH	Temp/Hum	24.3(°C) / 60%RH
Test Item	Band Edge	Test Date	May 30, 2023
Polarize	Vertical	Test Engineer	Czerny Lin
Detector	Peak / Average		

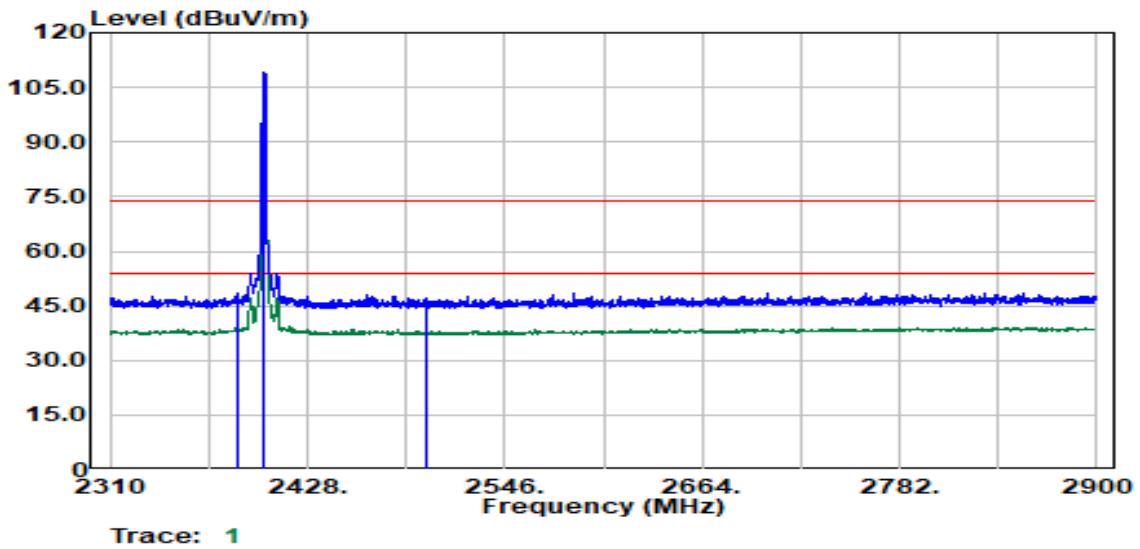

Freq. (MHz)	Detector Mode (PK/QP/AV)	Spectrum Reading Level (dBμV)	Factor (dB)	Actual FS (dBμV/m)	Limit @3m (dBμV/m)	Margin (dB)
2386.03	Average	34.62	4.80	39.42	54.00	-14.58
2386.53	Peak	43.54	4.80	48.34	74.00	-25.66
2402.00	Peak	102.61	4.51	107.13	--	--
2402.00	Average	102.07	4.51	106.58	--	--
2499.08	Peak	42.55	4.64	47.19	74.00	-26.81
2499.83	Average	33.43	4.65	38.08	54.00	-15.92

Report No.: TMWK2305001496KR

Test Mode:	BLE-1Mbps Low CH	Temp/Hum	24.3(°C) / 60%RH
Test Item	Band Edge	Test Date	May 30, 2023
Polarize	Horizontal	Test Engineer	Czerny Lin
Detector	Peak / Average		

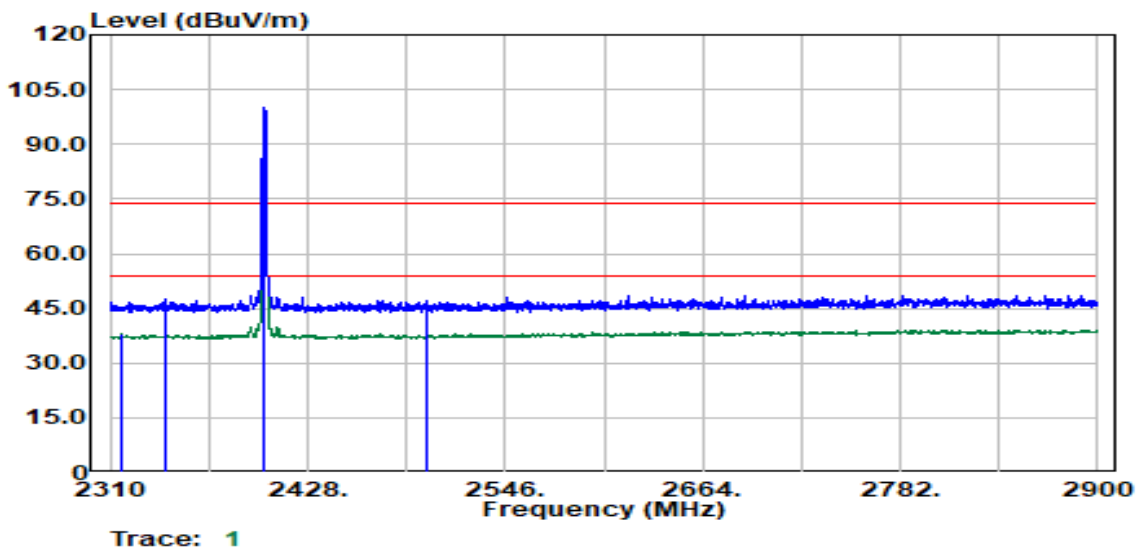

Freq. (MHz)	Detector Mode (PK/QP/AV)	Spectrum Reading Level (dBμV)	Factor (dB)	Actual FS (dBμV/m)	Limit @3m (dBμV/m)	Margin (dB)
2317.25	Average	33.23	4.68	37.91	54.00	-16.09
2342.26	Peak	42.89	4.80	47.69	74.00	-26.31
2402.00	Peak	93.45	4.51	97.96	--	--
2402.00	Average	92.93	4.51	97.44	--	--
2498.58	Peak	42.34	4.64	46.98	74.00	-27.02
2499.33	Average	33.04	4.64	37.68	54.00	-16.32

Report No.: TMWK2305001496KR

Test Mode:	BLE-1Mbps High CH	Temp/Hum	24.3(°C) / 60%RH
Test Item	Band Edge	Test Date	May 30, 2023
Polarize	Vertical	Test Engineer	Czerny Lin
Detector	Peak / Average		

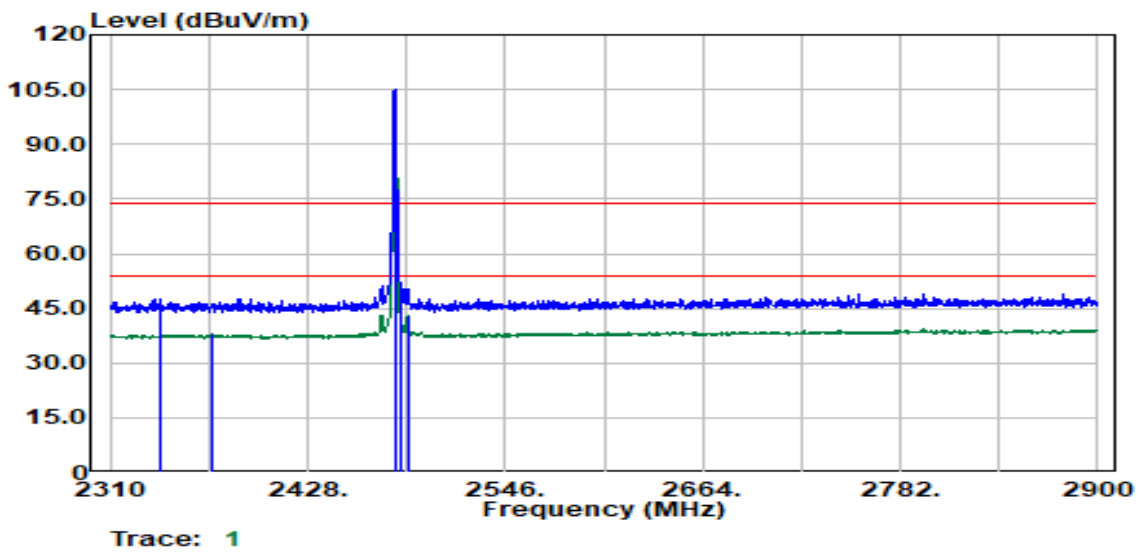

Freq. (MHz)	Detector Mode (PK/QP/AV)	Spectrum Reading Level (dBμV)	Factor (dB)	Actual FS (dBμV/m)	Limit @3m (dBμV/m)	Margin (dB)
2339.51	Peak	43.00	4.77	47.76	74.00	-26.24
2370.28	Average	33.25	4.69	37.94	54.00	-16.06
2480.00	Peak	100.25	4.65	104.90	--	--
2480.00	Average	99.73	4.65	104.37	--	--
2484.07	Peak	46.41	4.61	51.02	74.00	-22.98
2487.58	Average	38.63	4.57	43.21	54.00	-10.79

Report No.: TMWK2305001496KR

Test Mode:	BLE-1Mbps High CH	Temp/Hum	24.3(°C) / 60%RH
Test Item	Band Edge	Test Date	May 30, 2023
Polarize	Horizontal	Test Engineer	Czerny Lin
Detector	Peak / Average		

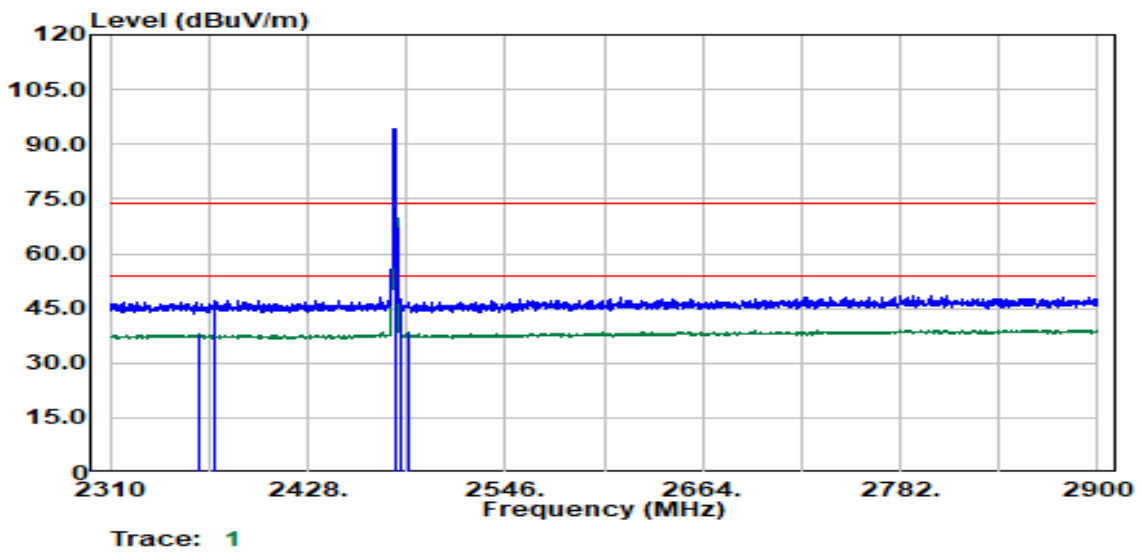

Freq. (MHz)	Detector Mode (PK/QP/AV)	Spectrum Reading Level (dBμV)	Factor (dB)	Actual FS (dBμV/m)	Limit @3m (dBμV/m)	Margin (dB)
2362.77	Average	33.28	4.76	38.04	54.00	-15.96
2373.03	Peak	42.22	4.72	46.95	74.00	-27.05
2480.00	Peak	89.60	4.65	94.25	--	--
2480.00	Average	89.09	4.65	93.74	--	--
2484.32	Peak	42.82	4.60	47.42	74.00	-26.58
2487.83	Average	33.79	4.57	38.36	54.00	-15.64

Test Mode:	BLE-2Mbps Low CH	Temp/Hum	24.3(°C) / 60%RH
Test Item	Band Edge	Test Date	May 30, 2023
Polarize	Vertical	Test Engineer	Czerny Lin
Detector	Peak / Average		

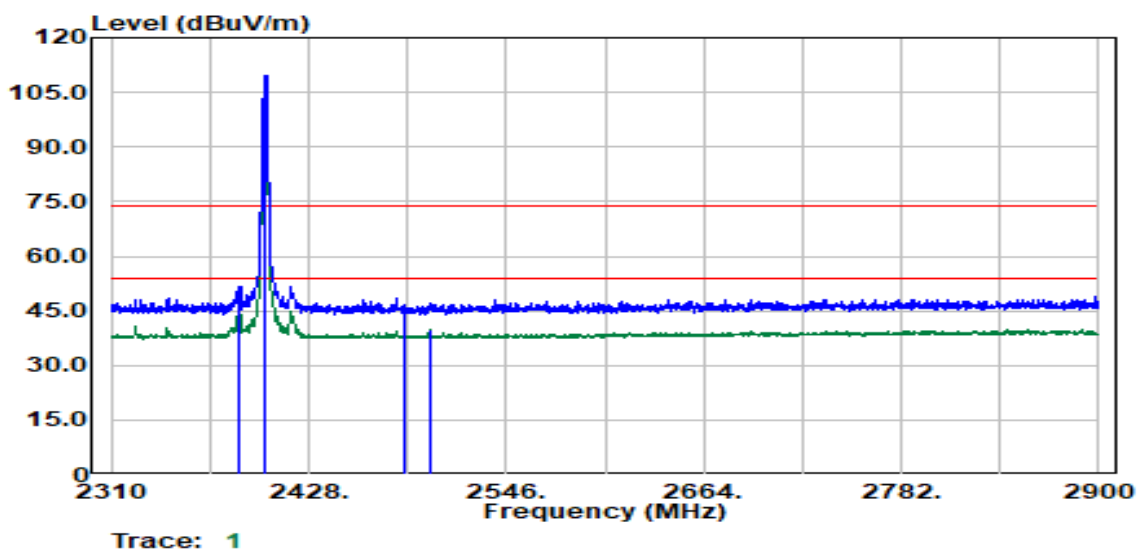

Freq. (MHz)	Detector Mode (PK/QP/AV)	Spectrum Reading Level (dBμV)	Factor (dB)	Actual FS (dBμV/m)	Limit @3m (dBμV/m)	Margin (dB)
2386.53	Peak	46.89	4.80	51.69	74.00	-22.31
2386.78	Average	40.05	4.80	44.85	54.00	-9.15
2402.00	Peak	103.89	4.51	108.40	--	--
2402.00	Average	102.04	4.51	106.56	--	--
2485.07	Peak	42.14	4.60	46.73	74.00	-27.27
2500.08	Average	35.03	4.65	39.68	54.00	-14.32

Test Mode:	BLE-2Mbps Low CH	Temp/Hum	24.3(°C) / 60%RH
Test Item	Band Edge	Test Date	May 30, 2023
Polarize	Horizontal	Test Engineer	Czerny Lin
Detector	Peak / Average		

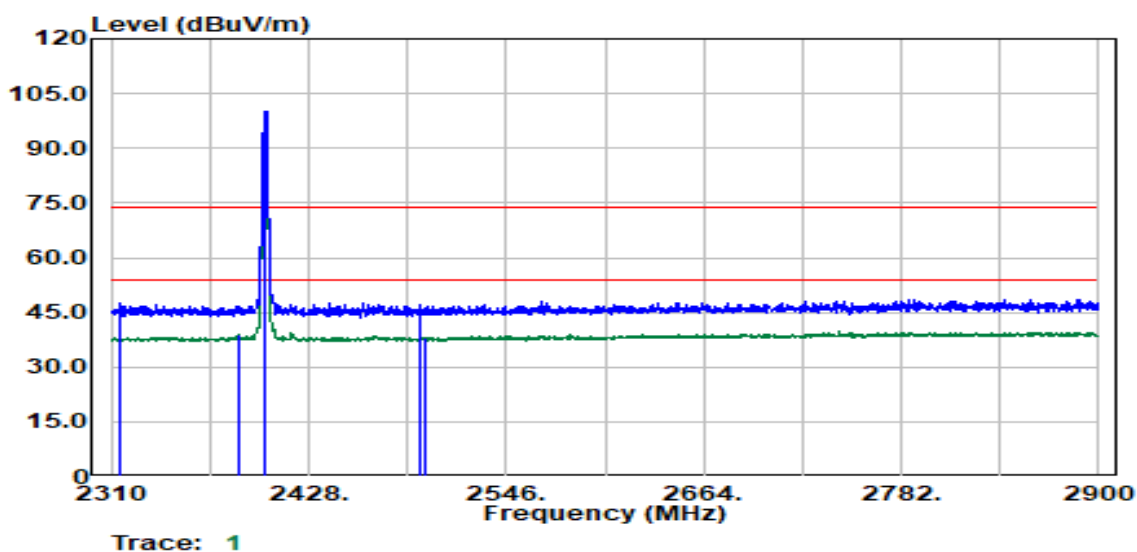

Freq. (MHz)	Detector Mode (PK/QP/AV)	Spectrum Reading Level (dBμV)	Factor (dB)	Actual FS (dBμV/m)	Limit @3m (dBμV/m)	Margin (dB)
2315.50	Peak	42.71	4.70	47.41	74.00	-26.59
2386.53	Average	34.24	4.80	39.04	54.00	-14.96
2402.00	Peak	94.73	4.51	99.25	--	--
2402.00	Average	92.85	4.51	97.36	--	--
2493.83	Peak	42.64	4.59	47.23	74.00	-26.77
2496.83	Average	33.47	4.62	38.09	54.00	-15.91

Report No.: TMWK2305001496KR

Test Mode:	BLE-2Mbps High CH	Temp/Hum	24.3(°C) / 60%RH
Test Item	Band Edge	Test Date	May 30, 2023
Polarize	Vertical	Test Engineer	Czerny Lin
Detector	Peak / Average		

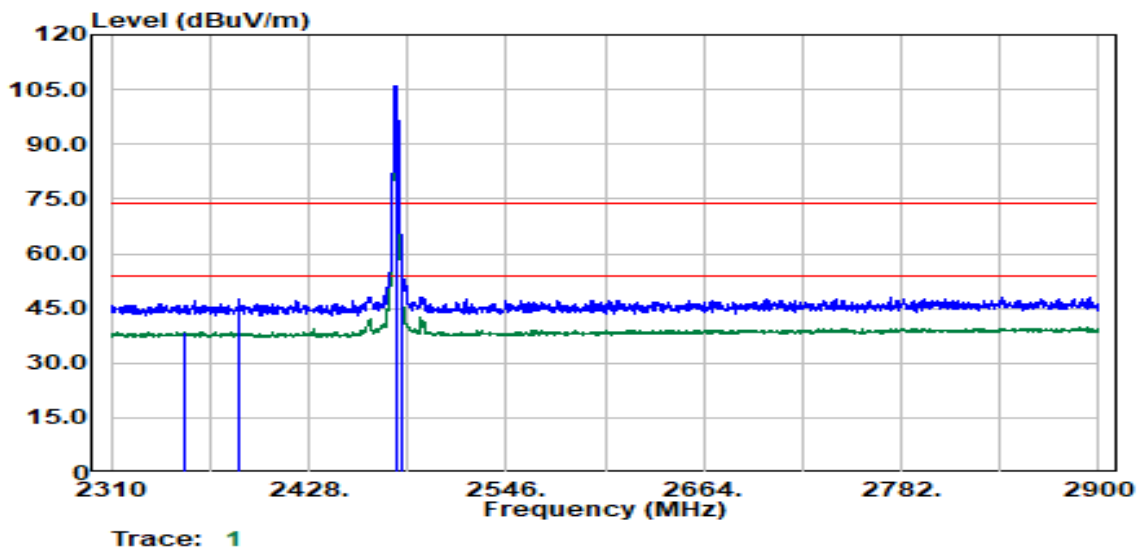

Freq. (MHz)	Detector Mode (PK/QP/AV)	Spectrum Reading Level (dB μ V)	Factor (dB)	Actual FS (dB μ V/m)	Limit @3m (dB μ V/m)	Margin (dB)
2353.52	Average	33.84	4.85	38.68	54.00	-15.32
2385.53	Peak	43.18	4.80	47.98	74.00	-26.02
2480.00	Peak	101.27	4.65	105.92	--	--
2480.00	Average	99.48	4.65	104.13	--	--
2483.57	Average	43.87	4.61	48.48	54.00	-5.52
2484.07	Peak	53.68	4.61	58.29	74.00	-15.71

Report No.: TMWK2305001496KR

Test Mode:	BLE-2Mbps High CH	Temp/Hum	24.3(°C) / 60%RH
Test Item	Band Edge	Test Date	May 30, 2023
Polarize	Horizontal	Test Engineer	Czerny Lin
Detector	Peak / Average		

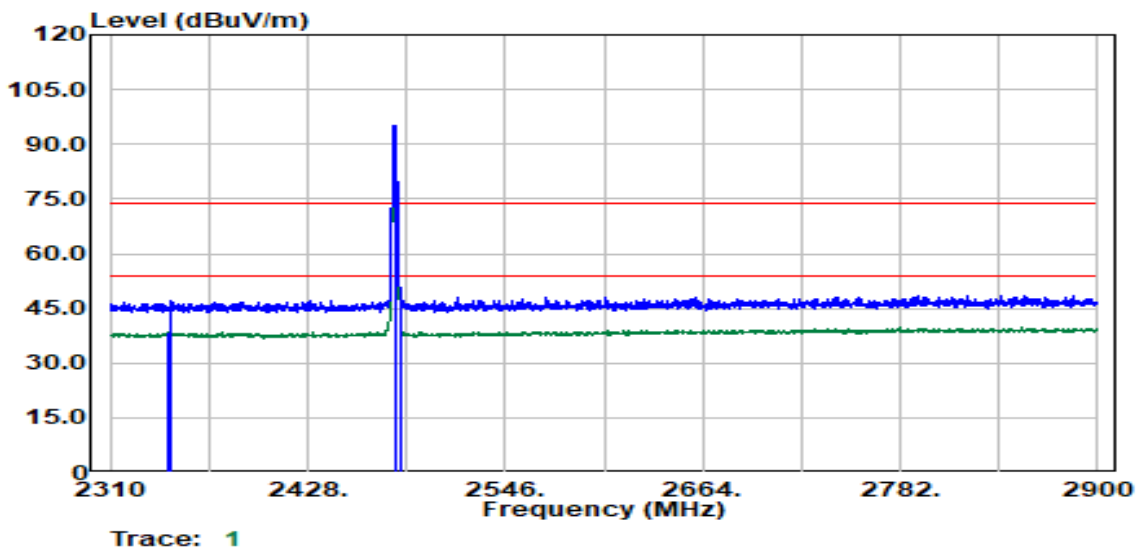

Freq. (MHz)	Detector Mode (PK/QP/AV)	Spectrum Reading Level (dBμV)	Factor (dB)	Actual FS (dBμV/m)	Limit @3m (dBμV/m)	Margin (dB)
2344.01	Average	33.59	4.82	38.41	54.00	-15.59
2346.77	Peak	42.16	4.85	47.01	74.00	-26.99
2480.00	Peak	90.32	4.65	94.96	--	--
2480.00	Average	88.41	4.65	93.05	--	--
2483.57	Average	35.15	4.61	39.76	54.00	-14.24
2483.82	Peak	43.04	4.61	47.65	74.00	-26.35

Band Edge Test Data
Test Mode: Mode 2 (PIFA Antenna)

Test Mode:	BLE-1Mbps Low CH	Temp/Hum	25.4(°C) / 57%RH
Test Item	Band Edge	Test Date	June 6, 2023
Polarize	Vertical	Test Engineer	Czerny Lin
Detector	Peak / Average		

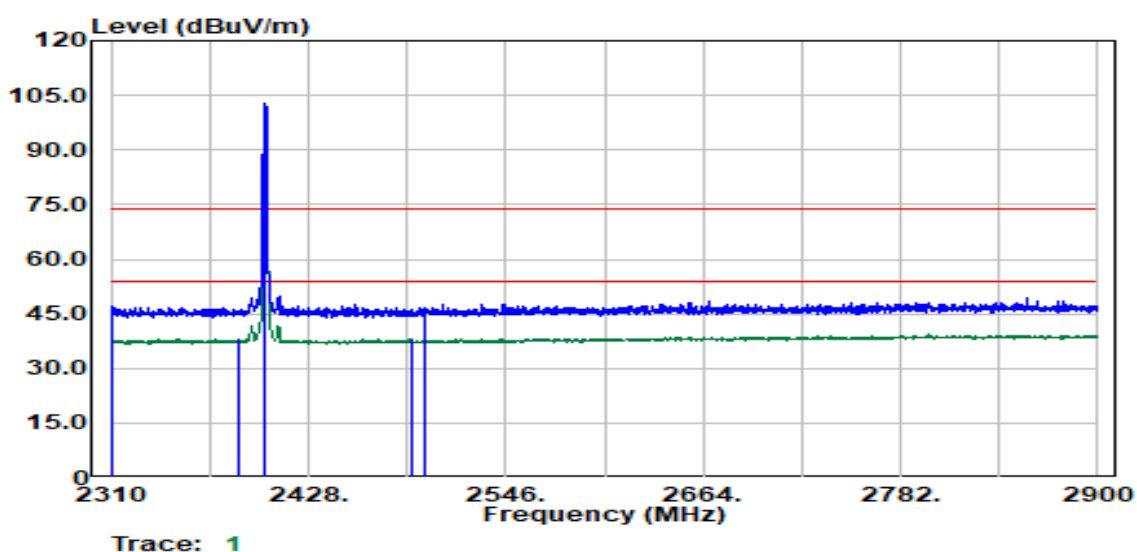

Freq. (MHz)	Detector Mode (PK/QP/AV)	Spectrum Reading Level (dBμV)	Factor (dB)	Actual FS (dBμV/m)	Limit @3m (dBμV/m)	Margin (dB)
2310.75	Peak	42.47	4.74	47.21	74.00	-26.79
2387.03	Average	33.26	4.80	38.06	54.00	-15.94
2402.00	Peak	98.08	4.51	102.59	--	--
2402.00	Average	97.49	4.51	102.00	--	--
2489.33	Average	33.58	4.55	38.14	54.00	-15.86
2497.83	Peak	41.97	4.63	46.60	74.00	-27.40

Report No.: TMWK2305001496KR

Test Mode:	BLE-1Mbps Low CH	Temp/Hum	25.4(°C) / 57%RH
Test Item	Band Edge	Test Date	June 6, 2023
Polarize	Horizontal	Test Engineer	Czerny Lin
Detector	Peak / Average		

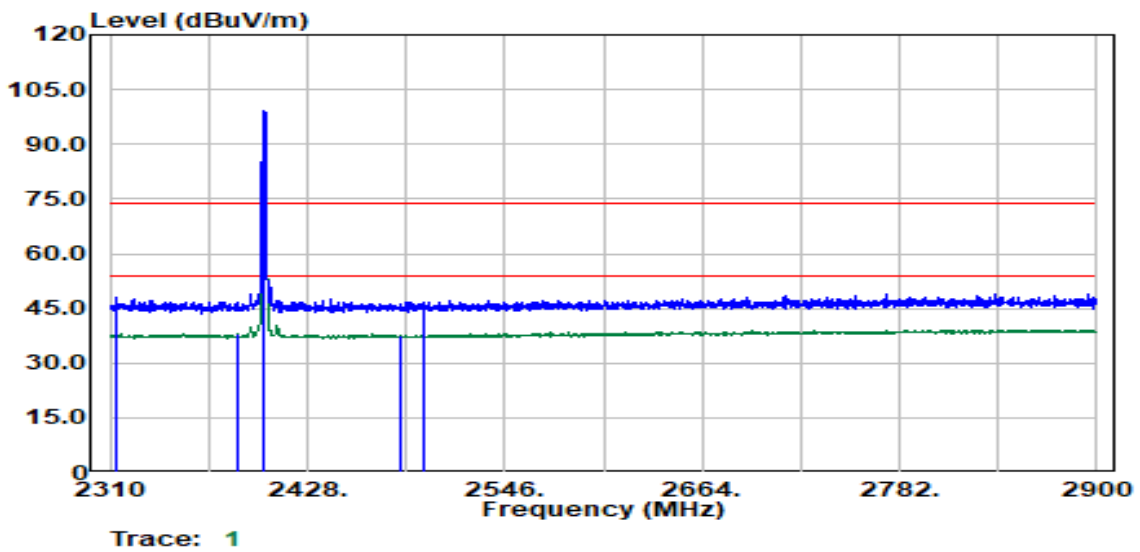

Freq. (MHz)	Detector Mode (PK/QP/AV)	Spectrum Reading Level (dBμV)	Factor (dB)	Actual FS (dBμV/m)	Limit @3m (dBμV/m)	Margin (dB)
2314.00	Peak	43.19	4.71	47.90	74.00	-26.10
2386.03	Average	33.16	4.80	37.96	54.00	-16.04
2402.00	Peak	94.67	4.51	99.18	--	--
2402.00	Average	94.08	4.51	98.59	--	--
2483.57	Average	33.05	4.61	37.67	54.00	-16.33
2497.33	Peak	42.14	4.62	46.76	74.00	-27.24

Report No.: TMWK2305001496KR

Test Mode:	BLE-1Mbps High CH	Temp/Hum	25.4(°C) / 57%RH
Test Item	Band Edge	Test Date	June 6, 2023
Polarize	Vertical	Test Engineer	Czerny Lin
Detector	Peak / Average		

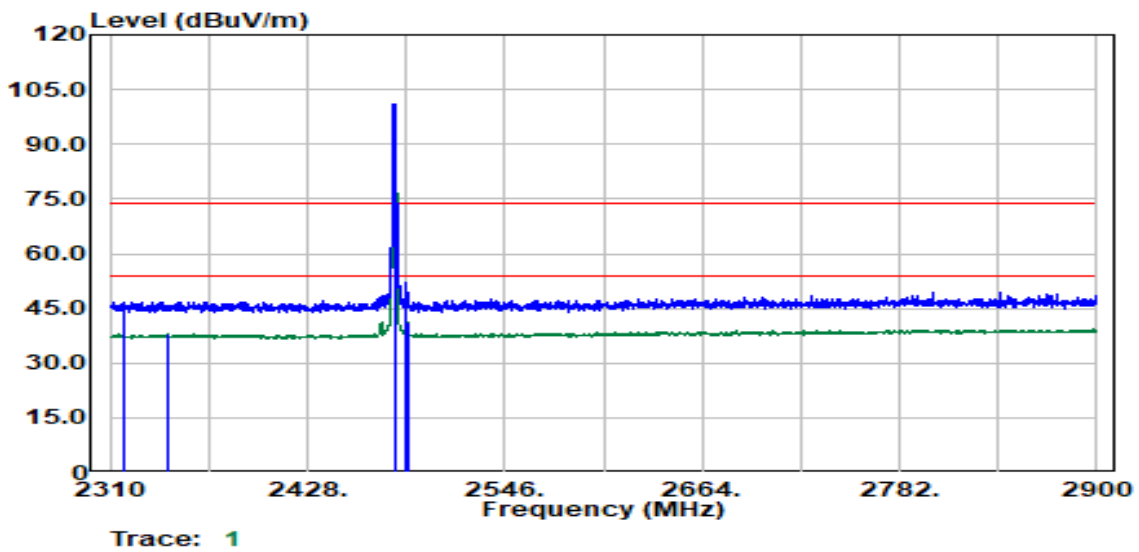

Freq. (MHz)	Detector Mode (PK/QP/AV)	Spectrum Reading Level (dBμV)	Factor (dB)	Actual FS (dBμV/m)	Limit @3m (dBμV/m)	Margin (dB)
2318.50	Peak	42.14	4.67	46.81	74.00	-27.19
2344.77	Average	33.15	4.82	37.98	54.00	-16.02
2480.00	Peak	96.34	4.65	100.99	--	--
2480.00	Average	95.79	4.65	100.44	--	--
2486.33	Peak	47.41	4.58	52.00	74.00	-22.00
2487.58	Average	36.51	4.57	41.08	54.00	-12.92

Report No.: TMWK2305001496KR

Test Mode:	BLE-1Mbps High CH	Temp/Hum	25.4(°C) / 57%RH
Test Item	Band Edge	Test Date	June 6, 2023
Polarize	Horizontal	Test Engineer	Czerny Lin
Detector	Peak / Average		

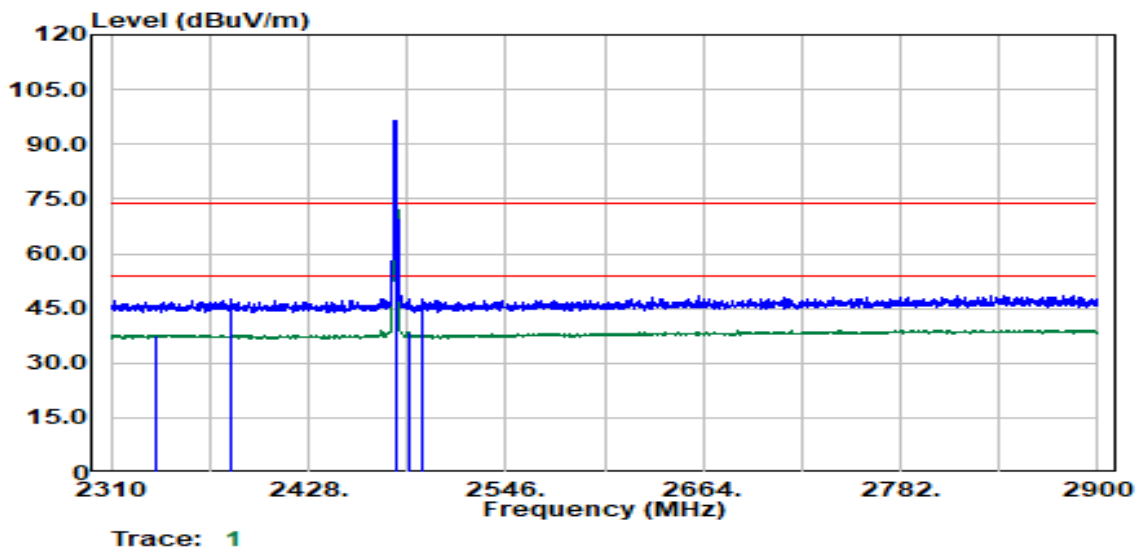

Freq. (MHz)	Detector Mode (PK/QP/AV)	Spectrum Reading Level (dB μ V)	Factor (dB)	Actual FS (dB μ V/m)	Limit @3m (dB μ V/m)	Margin (dB)
2337.51	Average	33.03	4.75	37.78	54.00	-16.22
2381.28	Peak	42.55	4.80	47.35	74.00	-26.65
2480.00	Peak	91.87	4.65	96.52	--	--
2480.00	Average	91.32	4.65	95.97	--	--
2488.08	Average	33.99	4.57	38.56	54.00	-15.44
2495.58	Peak	43.03	4.60	47.63	74.00	-26.37

Report No.: TMWK2305001496KR

Test Mode:	BLE-2Mbps Low CH	Temp/Hum	25.4(°C) / 57%RH
Test Item	Band Edge	Test Date	June 6, 2023
Polarize	Vertical	Test Engineer	Czerny Lin
Detector	Peak / Average		

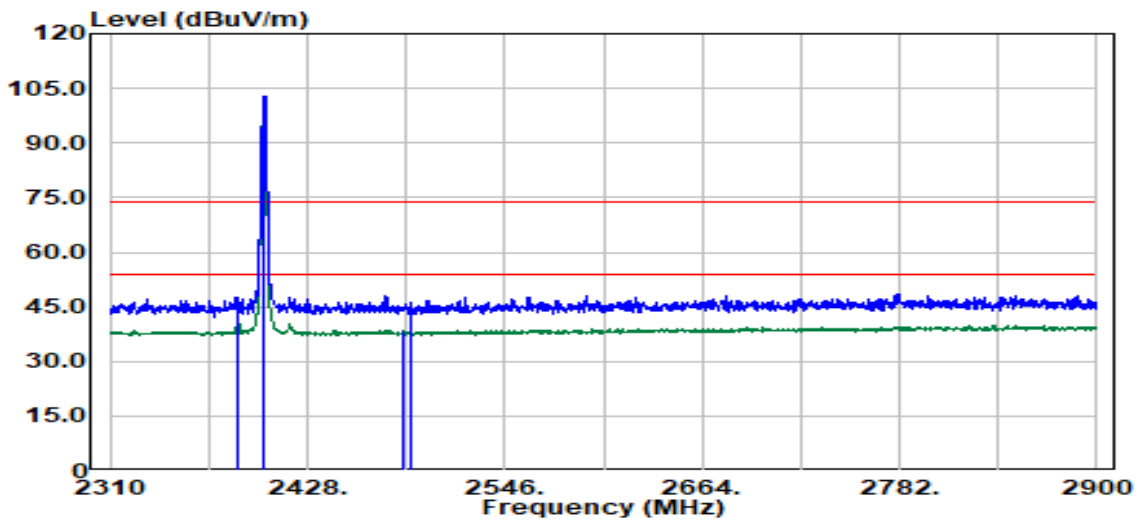

Freq. (MHz)	Detector Mode (PK/QP/AV)	Spectrum Reading Level (dB μ V)	Factor (dB)	Actual FS (dB μ V/m)	Limit @3m (dB μ V/m)	Margin (dB)
2386.28	Average	35.74	4.80	40.54	54.00	-13.46
2386.53	Peak	43.38	4.80	48.18	74.00	-25.82
2402.00	Peak	98.06	4.51	102.57	--	--
2402.00	Average	96.17	4.51	100.68	--	--
2485.57	Average	33.68	4.59	38.27	54.00	-15.73
2489.83	Peak	42.12	4.55	46.67	74.00	-27.33

Report No.: TMWK2305001496KR

Test Mode:	BLE-2Mbps Low CH	Temp/Hum	25.4(°C) / 57%RH
Test Item	Band Edge	Test Date	June 6, 2023
Polarize	Horizontal	Test Engineer	Czerny Lin
Detector	Peak / Average		

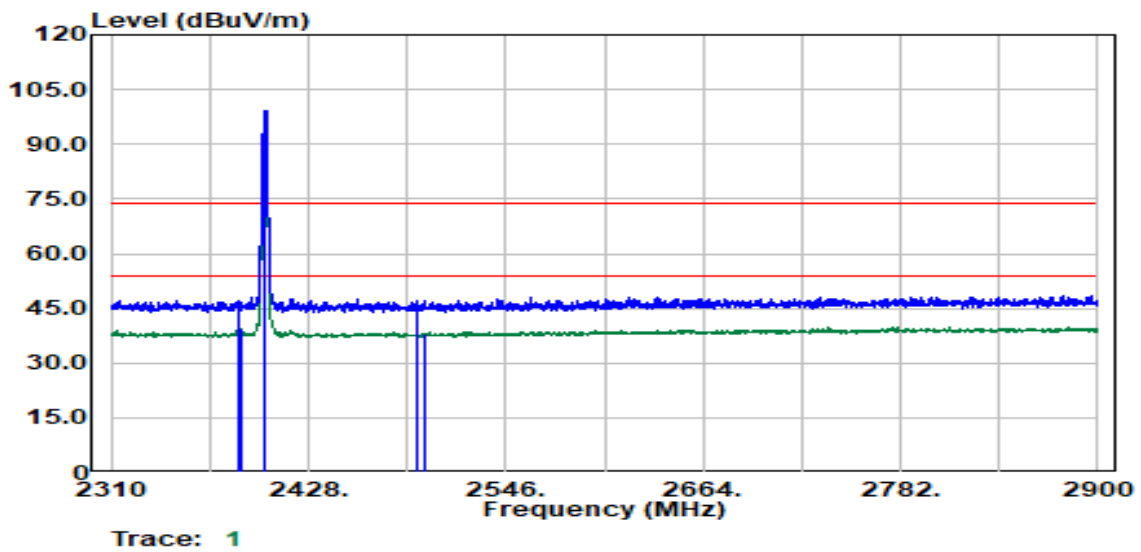

Freq. (MHz)	Detector Mode (PK/QP/AV)	Spectrum Reading Level (dB μ V)	Factor (dB)	Actual FS (dB μ V/m)	Limit @3m (dB μ V/m)	Margin (dB)
2386.53	Peak	42.31	4.80	47.12	74.00	-26.88
2387.28	Average	34.46	4.80	39.26	54.00	-14.74
2402.00	Peak	93.72	4.51	98.23	--	--
2402.00	Average	91.88	4.51	96.39	--	--
2492.33	Peak	42.67	4.57	47.24	74.00	-26.76
2498.08	Average	33.52	4.63	38.15	54.00	-15.85

Report No.: TMWK2305001496KR

Test Mode:	BLE-2Mbps High CH	Temp/Hum	25.4(°C) / 57%RH
Test Item	Band Edge	Test Date	June 6, 2023
Polarize	Vertical	Test Engineer	Czerny Lin
Detector	Peak / Average		

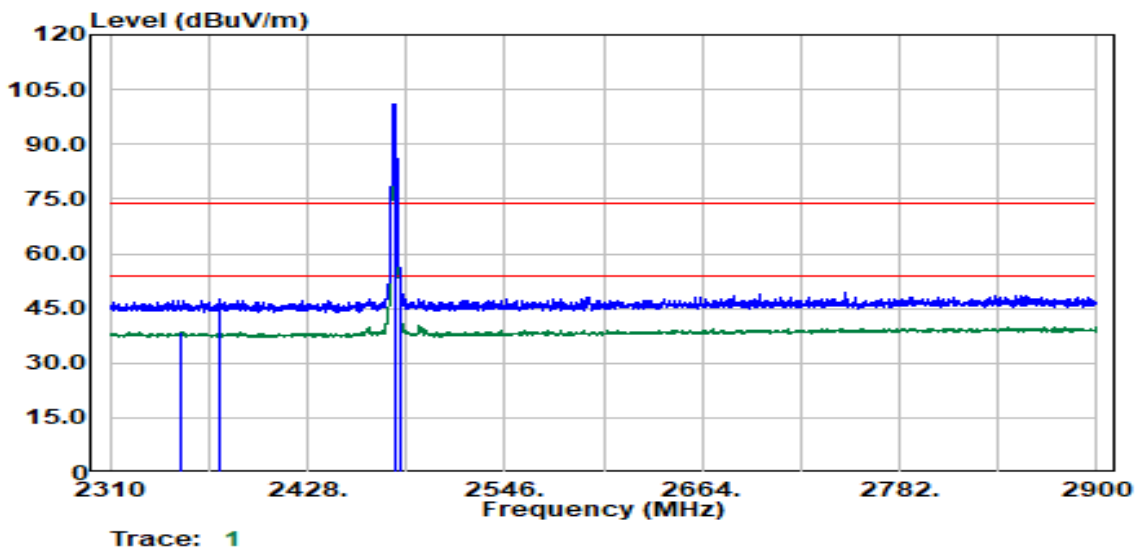

Freq. (MHz)	Detector Mode (PK/QP/AV)	Spectrum Reading Level (dBµV)	Factor (dB)	Actual FS (dBUV/m)	Limit @3m (dBUV/m)	Margin (dB)
2352.27	Average	33.72	4.86	38.58	54.00	-15.42
2375.28	Peak	42.73	4.75	47.47	74.00	-26.53
2480.00	Peak	96.23	4.65	100.88	--	--
2480.00	Average	94.37	4.65	99.01	--	--
2483.57	Peak	48.16	4.61	52.77	74.00	-21.23
2483.57	Average	39.24	4.61	43.85	54.00	-10.15

Report No.: TMWK2305001496KR

Test Mode:	BLE-2Mbps High CH	Temp/Hum	25.4(°C) / 57%RH
Test Item	Band Edge	Test Date	June 6, 2023
Polarize	Horizontal	Test Engineer	Czerny Lin
Detector	Peak / Average		

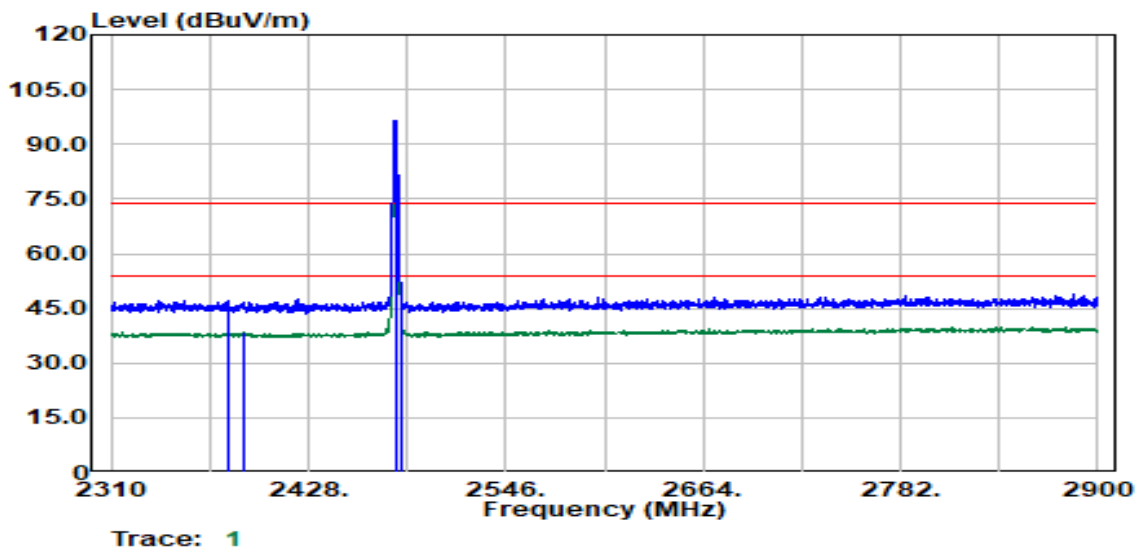

Freq. (MHz)	Detector Mode (PK/QP/AV)	Spectrum Reading Level (dB μ V)	Factor (dB)	Actual FS (dB μ V/m)	Limit @3m (dB μ V/m)	Margin (dB)
2380.78	Peak	42.36	4.80	47.16	74.00	-26.84
2388.78	Average	33.53	4.80	38.33	54.00	-15.67
2480.00	Peak	91.70	4.65	96.35	--	--
2480.00	Average	89.84	4.65	94.48	--	--
2483.57	Peak	44.99	4.61	49.60	74.00	-24.40
2483.57	Average	35.86	4.61	40.47	54.00	-13.53

Report No.: TMWK2305001496KR

Below 1G Test Data
Test Mode: Mode 1 (Dipole Antenna)

Test Mode:	BLE-1Mbps Mid CH	Temp/Hum	24.5(°C) / 62%RH
Test Item	30MHz-1GHz	Test Date	May 31, 2023
Polarize	Vertical	Test Engineer	Czerny Lin
Detector	Peak		

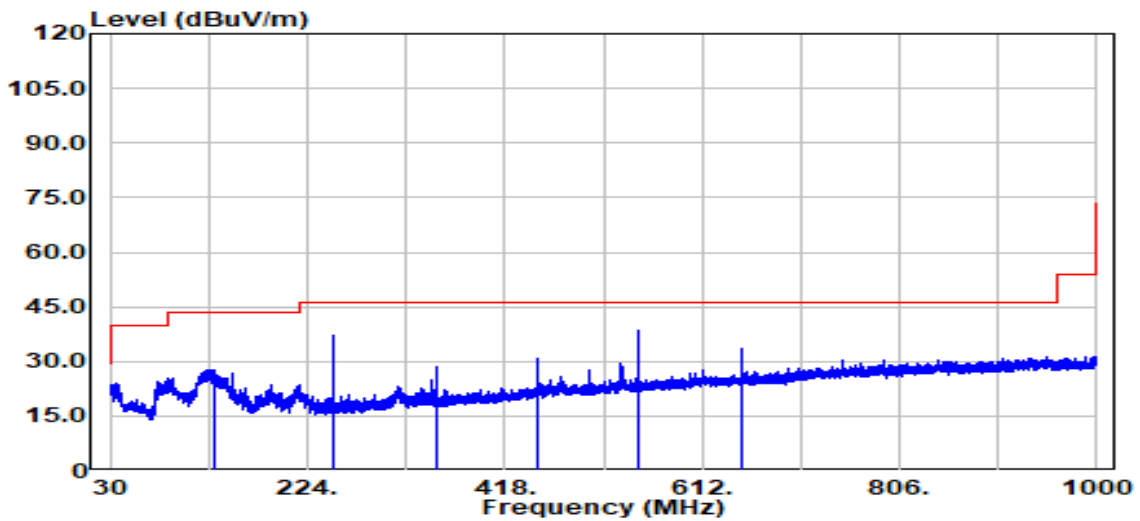

Freq. (MHz)	Detector Mode (PK/QP/AV)	Spectrum Reading Level (dBµV)	Factor (dB)	Actual FS (dBµV/m)	Limit @3m (dBµV/m)	Margin (dB)
131.56	Peak	42.15	-14.42	27.73	43.50	-15.77
250.00	Peak	51.10	-14.00	37.10	46.00	-8.90
350.00	Peak	39.85	-11.18	28.67	46.00	-17.33
450.01	Peak	39.26	-8.31	30.95	46.00	-15.05
550.02	Peak	45.25	-6.69	38.56	46.00	-7.44
650.02	Peak	37.76	-4.30	33.46	46.00	-12.54

Note: No emission found between lowest internal used/generated frequency to 30MHz (9kHz~30MHz).

Report No.: TMWK2305001496KR

Test Mode:	BLE-1Mbps Mid CH	Temp/Hum	24.5(°C) / 62%RH
Test Item	30MHz-1GHz	Test Date	May 31, 2023
Polarize	Horizontal	Test Engineer	Czerny Lin
Detector	Peak		

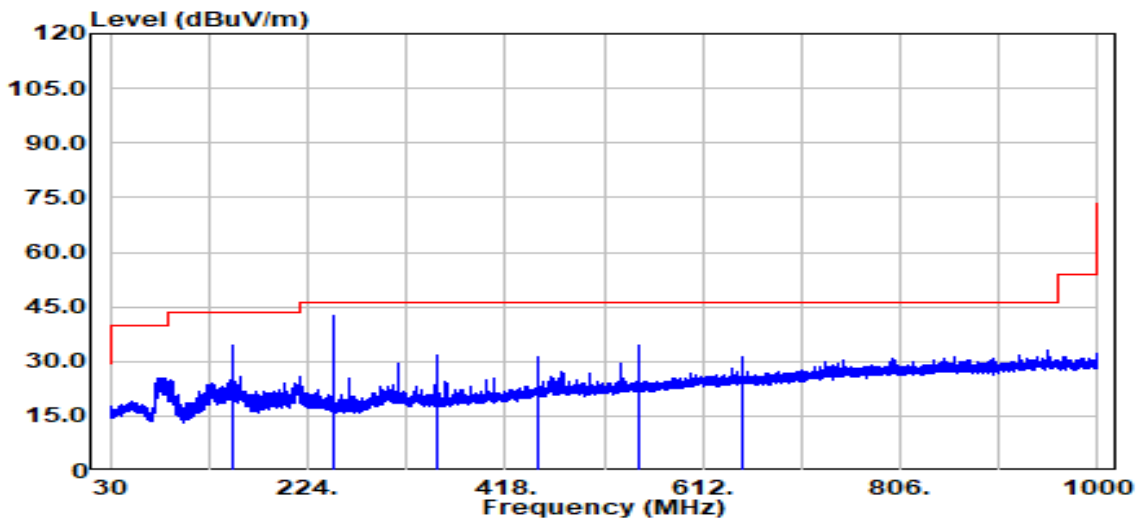

Freq. (MHz)	Detector Mode (PK/QP/AV)	Spectrum Reading Level (dB μ V)	Factor (dB)	Actual FS (dB μ V/m)	Limit @3m (dB μ V/m)	Margin (dB)
149.99	Peak	47.45	-12.86	34.59	43.50	-8.91
250.00	Peak	56.72	-14.00	42.72	46.00	-3.28
350.00	Peak	42.75	-11.18	31.57	46.00	-14.43
450.01	Peak	39.45	-8.31	31.14	46.00	-14.86
550.02	Peak	41.15	-6.69	34.46	46.00	-11.54
650.02	Peak	35.58	-4.30	31.28	46.00	-14.72

Note: No emission found between lowest internal used/generated frequency to 30MHz (9kHz~30MHz).

Report No.: TMWK2305001496KR

Below 1G Test Data
Test Mode: Mode 2 (PIFA Antenna)

Test Mode:	BLE-1Mbps Low CH	Temp/Hum	25.4(°C) / 57%RH
Test Item	30MHz-1GHz	Test Date	June 6, 2023
Polarize	Vertical	Test Engineer	Czerny Lin
Detector	Peak		

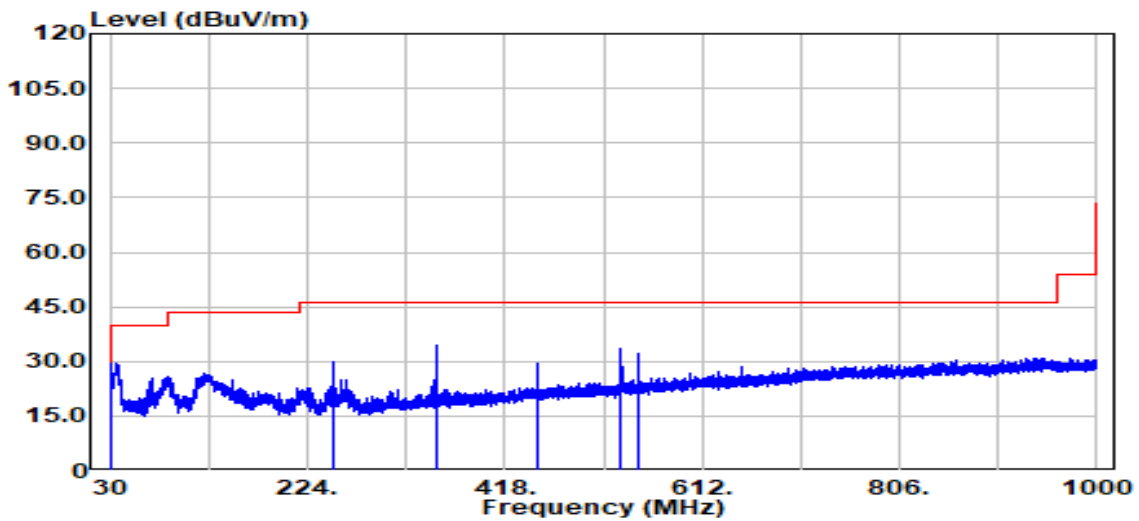

Freq. (MHz)	Detector Mode (PK/QP/AV)	Spectrum Reading Level (dBµV)	Factor (dB)	Actual FS (dBµV/m)	Limit @3m (dBµV/m)	Margin (dB)
30.58	Peak	43.55	-14.13	29.42	40.00	-10.58
250.00	Peak	44.01	-14.00	30.01	46.00	-15.99
350.00	Peak	45.81	-11.18	34.63	46.00	-11.37
450.01	Peak	37.56	-8.31	29.25	46.00	-16.75
531.10	Peak	40.37	-6.89	33.48	46.00	-12.52
550.02	Peak	38.64	-6.69	31.95	46.00	-14.05

Note: No emission found between lowest internal used/generated frequency to 30MHz (9kHz~30MHz).

Test Mode:	BLE-1Mbps Low CH	Temp/Hum	25.4(°C) / 57%RH
Test Item	30MHz-1GHz	Test Date	June 6, 2023
Polarize	Horizontal	Test Engineer	Czerny Lin
Detector	Peak		

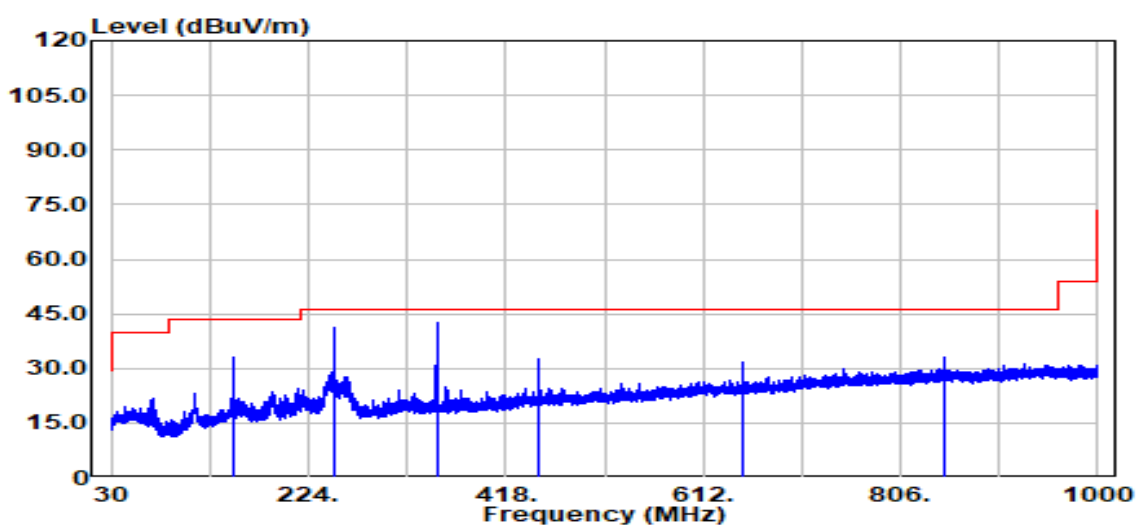

Freq. (MHz)	Detector Mode (PK/QP/AV)	Spectrum Reading Level (dBμV)	Factor (dB)	Actual FS (dBμV/m)	Limit @3m (dBμV/m)	Margin (dB)
149.99	Peak	45.95	-12.86	33.09	43.50	-10.41
250.00	Peak	55.01	-14.00	41.01	46.00	-4.99
350.00	Peak	53.77	-11.18	42.59	46.00	-3.41
450.01	Peak	40.72	-8.31	32.41	46.00	-13.59
650.02	Peak	35.85	-4.30	31.55	46.00	-14.45
850.04	Peak	33.95	-1.07	32.88	46.00	-13.12

Note: No emission found between lowest internal used/generated frequency to 30MHz (9kHz~30MHz).

Report No.: TMWK2305001496KR

Above 1G Test Data
Test Mode: Mode 1 (Dipole Antenna)

Test Mode:	BLE-1Mbps Low CH	Temp/Hum	24.3(°C) / 60%RH
Test Item	Harmonic	Test Date	May 30, 2023
Polarize	Vertical	Test Engineer	Czerny Lin
Detector	Peak / Average		

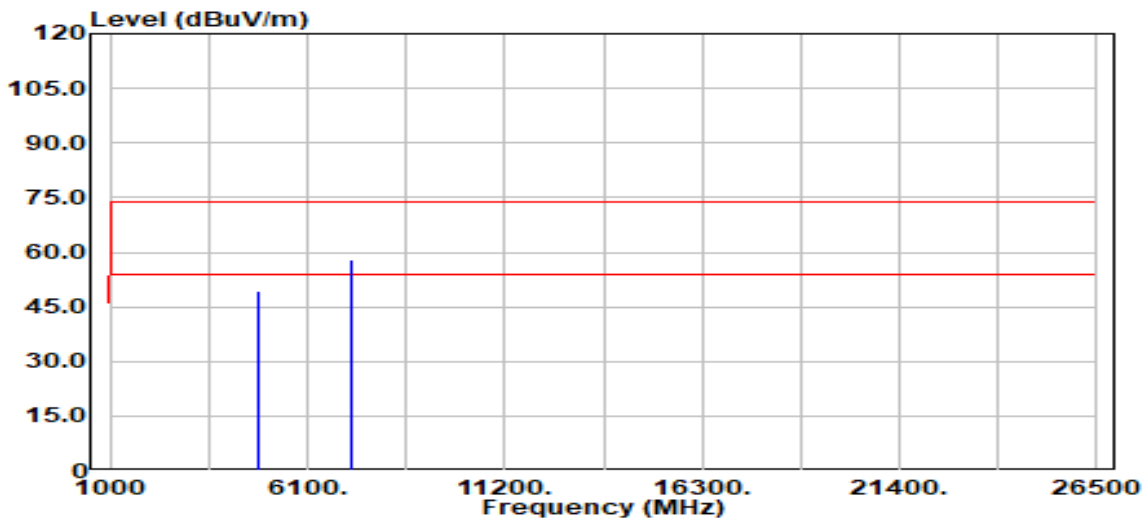

Freq. (MHz)	Detector Mode (PK/QP/AV)	Spectrum Reading Level (dBμV)	Factor (dB)	Actual FS (dBμV/m)	Limit @3m (dBμV/m)	Margin (dB)
4804.00	Peak	48.83	0.38	49.21	74.00	-24.79
4804.00	Average	43.22	0.38	43.61	54.00	-10.40
7206.00	Peak	52.82	5.33	58.15	74.00	-15.85
7206.00	Average	48.18	5.33	53.51	54.00	-0.49
N/A						

Remark:

1. Measuring frequencies from 1 GHz to the 10th harmonic of highest fundamental frequency.

Report No.: TMWK2305001496KR

Test Mode:	BLE-1Mbps Low CH	Temp/Hum	24.3(°C) / 60%RH
Test Item	Harmonic	Test Date	May 30, 2023
Polarize	Horizontal	Test Engineer	Czerny Lin
Detector	Peak / Average		

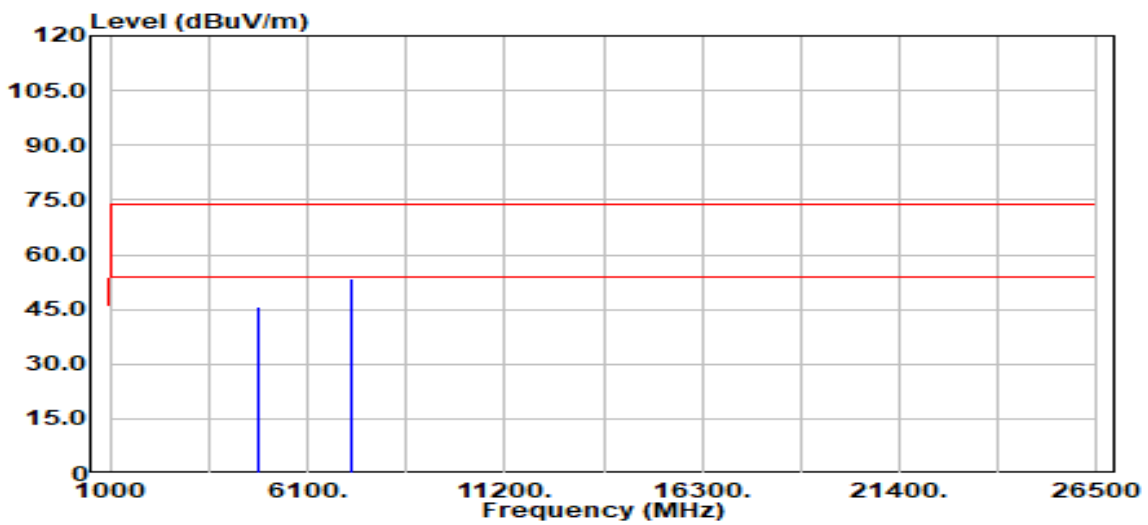

Freq. (MHz)	Detector Mode (PK/QP/AV)	Spectrum Reading Level (dBµV)	Factor (dB)	Actual FS (dBµV/m)	Limit @3m (dBµV/m)	Margin (dB)
4804.00	Peak	45.57	0.38	45.96	74.00	-28.04
4804.00	Average	40.78	0.38	41.17	54.00	-12.83
7206.00	Peak	48.31	5.33	53.63	74.00	-20.37
7206.00	Average	41.58	5.33	46.91	54.00	-7.09
N/A						

Remark:

1. Measuring frequencies from 1 GHz to the 10th harmonic of highest fundamental frequency.

Report No.: TMWK2305001496KR

Test Mode:	BLE-1Mbps Mid CH	Temp/Hum	24.3(°C) / 60%RH
Test Item	Harmonic	Test Date	May 30, 2023
Polarize	Vertical	Test Engineer	Czerny Lin
Detector	Peak / Average		

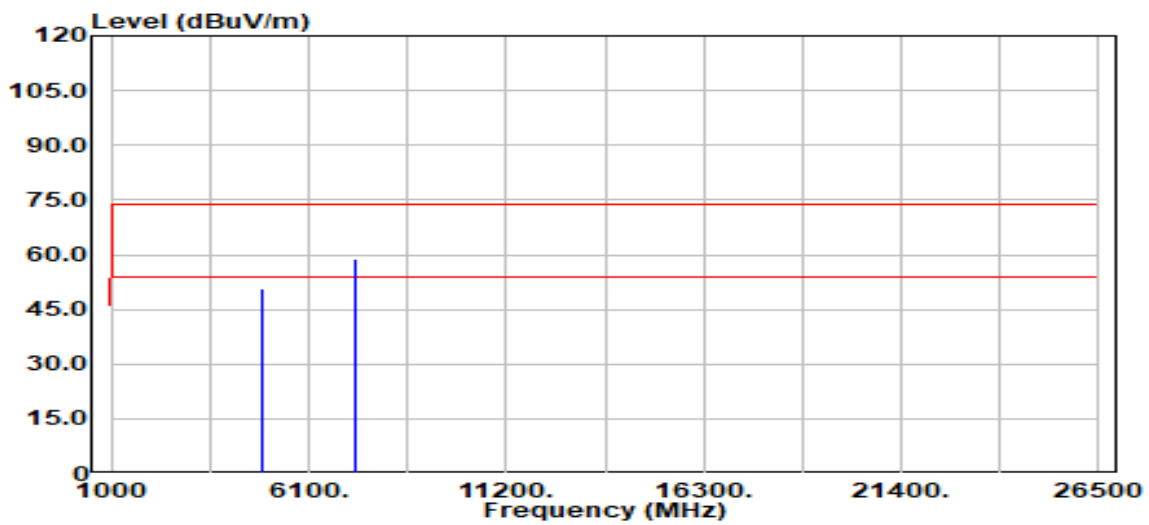

Freq. (MHz)	Detector Mode (PK/QP/AV)	Spectrum Reading Level (dBμV)	Factor (dB)	Actual FS (dBμV/m)	Limit @3m (dBμV/m)	Margin (dB)
4880.00	Peak	50.27	0.48	50.75	74.00	-23.25
4880.00	Average	44.52	0.48	45.00	54.00	-9.00
7320.00	Peak	53.26	5.48	58.75	74.00	-15.25
7320.00	Average	48.11	5.48	53.59	54.00	-0.41
N/A						

Remark:

1. Measuring frequencies from 1 GHz to the 10th harmonic of highest fundamental frequency.

Report No.: TMWK2305001496KR

Test Mode:	BLE-1Mbps Mid CH	Temp/Hum	24.3(°C) / 60%RH
Test Item	Harmonic	Test Date	May 30, 2023
Polarize	Horizontal	Test Engineer	Czerny Lin
Detector	Peak / Average		

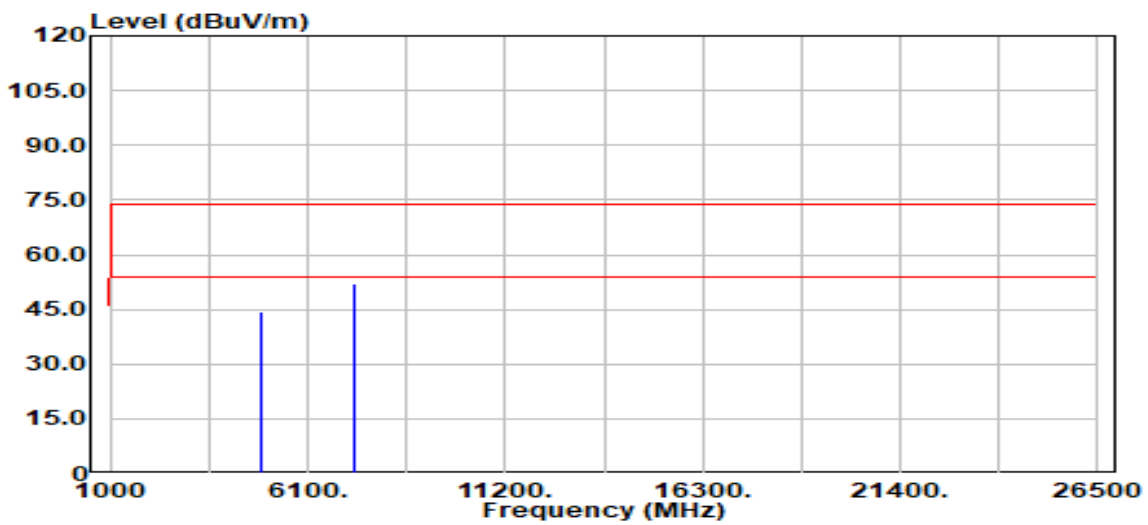

Freq. (MHz)	Detector Mode (PK/QP/AV)	Spectrum Reading Level (dBμV)	Factor (dB)	Actual FS (dBμV/m)	Limit @3m (dBμV/m)	Margin (dB)
4880.00	Peak	44.01	0.48	44.49	74.00	-29.51
4880.00	Average	38.92	0.48	39.40	54.00	-14.60
7320.00	Peak	46.38	5.48	51.86	74.00	-22.14
7320.00	Average	41.98	5.48	47.47	54.00	-6.53
N/A						

Remark:

1. Measuring frequencies from 1 GHz to the 10th harmonic of highest fundamental frequency.

Report No.: TMWK2305001496KR

Test Mode:	BLE-1Mbps High CH	Temp/Hum	24.3(°C) / 60%RH
Test Item	Harmonic	Test Date	May 30, 2023
Polarize	Vertical	Test Engineer	Czerny Lin
Detector	Peak / Average		

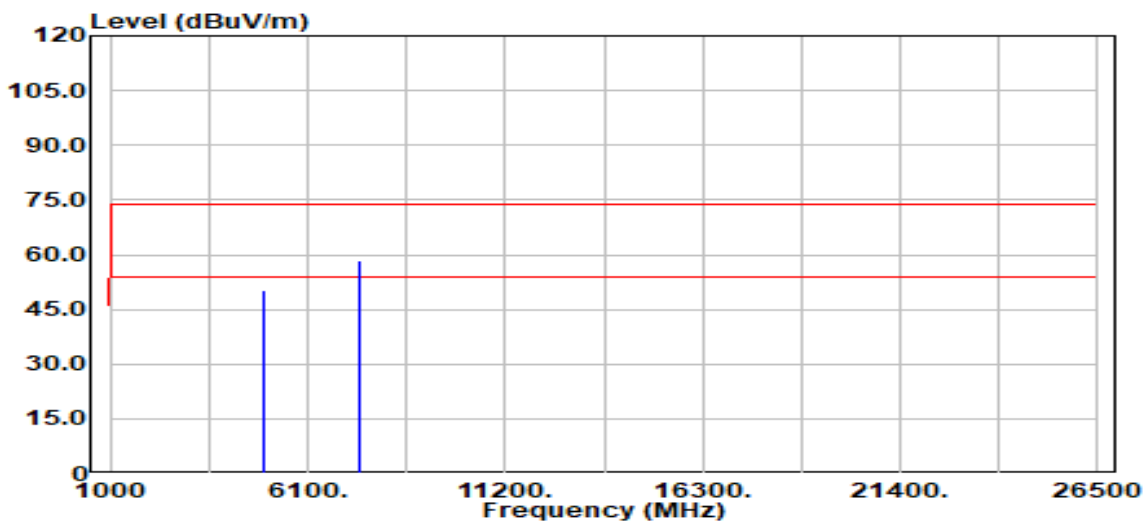

Freq. (MHz)	Detector Mode (PK/QP/AV)	Spectrum Reading Level (dBμV)	Factor (dB)	Actual FS (dBμV/m)	Limit @3m (dBμV/m)	Margin (dB)
4960.00	Peak	49.61	0.65	50.25	74.00	-23.75
4960.00	Average	43.00	0.65	43.65	54.00	-10.35
7440.00	Peak	52.63	5.56	58.19	74.00	-15.81
7440.00	Average	47.89	5.56	53.46	54.00	-0.54
N/A						

Remark:

1. Measuring frequencies from 1 GHz to the 10th harmonic of highest fundamental frequency.

Report No.: TMWK2305001496KR

Test Mode:	BLE-1Mbps High CH	Temp/Hum	24.3(°C) / 60%RH
Test Item	Harmonic	Test Date	May 30, 2023
Polarize	Horizontal	Test Engineer	Czerny Lin
Detector	Peak / Average		

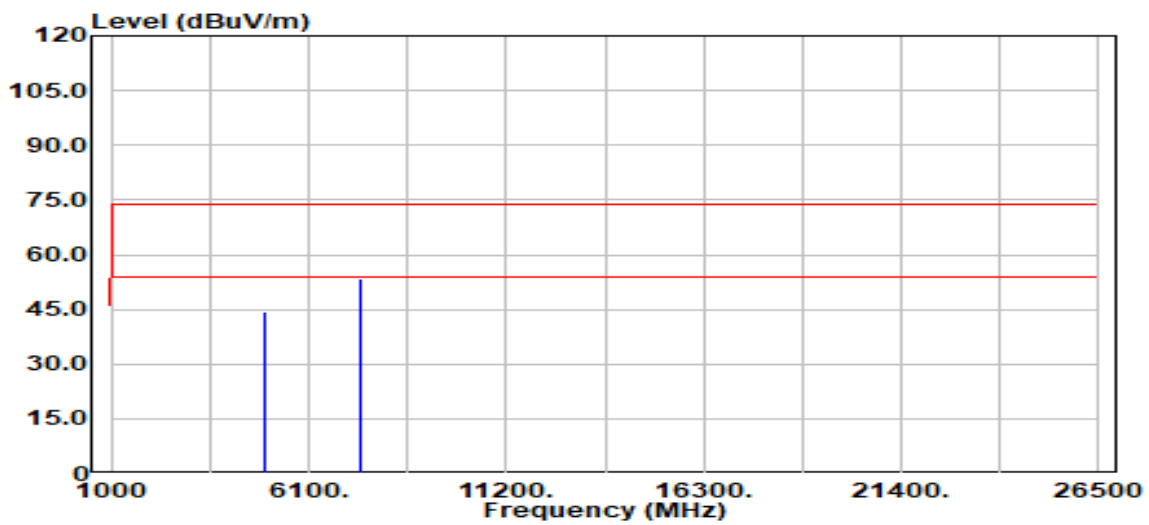

Freq. (MHz)	Detector Mode (PK/QP/AV)	Spectrum Reading Level (dBμV)	Factor (dB)	Actual FS (dBμV/m)	Limit @3m (dBμV/m)	Margin (dB)
4960.00	Peak	43.63	0.65	44.28	74.00	-29.72
4960.00	Average	38.54	0.65	39.19	54.00	-14.81
7440.00	Peak	48.05	5.56	53.62	74.00	-20.38
7440.00	Average	43.07	5.56	48.63	54.00	-5.37
N/A						

Remark:

1. Measuring frequencies from 1 GHz to the 10th harmonic of highest fundamental frequency.

Report No.: TMWK2305001496KR

Test Mode:	BLE-2Mbps Low CH	Temp/Hum	24.3(°C) / 60%RH
Test Item	Harmonic	Test Date	May 30, 2023
Polarize	Vertical	Test Engineer	Czerny Lin
Detector	Peak / Average		

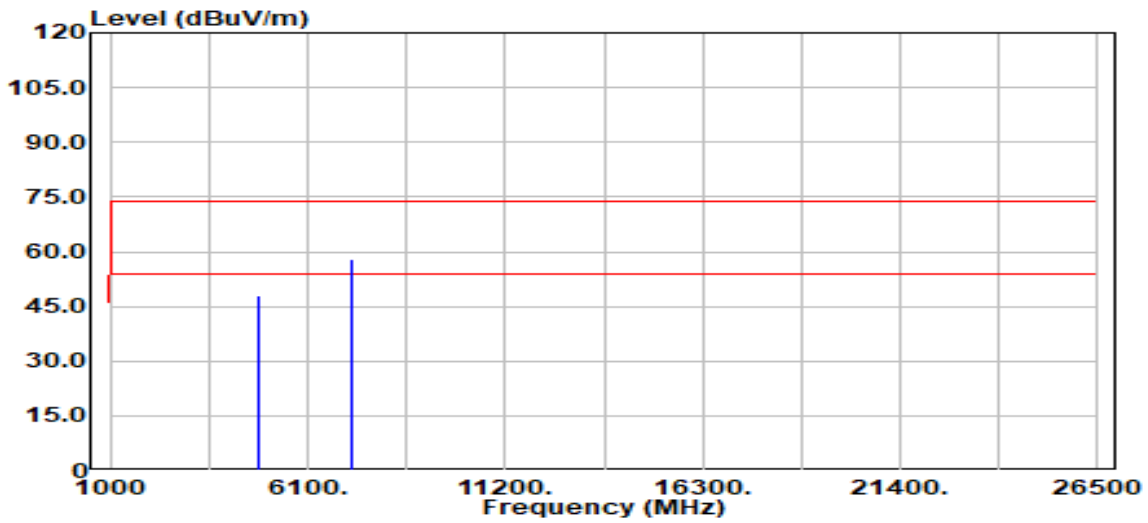

Freq. (MHz)	Detector Mode (PK/QP/AV)	Spectrum Reading Level (dBμV)	Factor (dB)	Actual FS (dBμV/m)	Limit @3m (dBμV/m)	Margin (dB)
4804.00	Peak	47.80	0.38	48.19	74.00	-25.81
4804.00	Average	44.99	0.38	45.37	54.00	-8.63
7206.00	Peak	52.55	5.33	57.88	74.00	-16.12
7206.00	Average	47.78	5.33	53.11	54.00	-0.89
N/A						

Remark:

1. Measuring frequencies from 1 GHz to the 10th harmonic of highest fundamental frequency.

Test Mode:	BLE-2Mbps Low CH	Temp/Hum	24.3(°C) / 60%RH
Test Item	Harmonic	Test Date	May 30, 2023
Polarize	Horizontal	Test Engineer	Czerny Lin
Detector	Peak / Average		

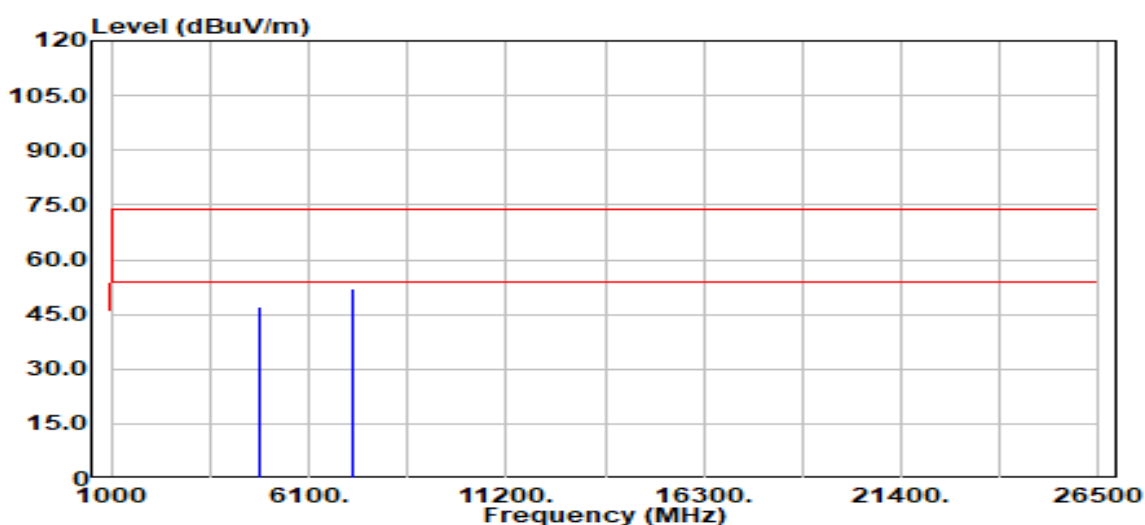

Freq. (MHz)	Detector Mode (PK/QP/AV)	Spectrum Reading Level (dBµV)	Factor (dB)	Actual FS (dBµV/m)	Limit @3m (dBµV/m)	Margin (dB)
4804.00	Peak	46.62	0.38	47.00	74.00	-27.00
4804.00	Average	39.78	0.38	40.17	54.00	-13.83
7206.00	Peak	46.76	5.33	52.08	74.00	-21.92
7206.00	Average	41.54	5.33	46.87	54.00	-7.13
N/A						

Remark:

1. Measuring frequencies from 1 GHz to the 10th harmonic of highest fundamental frequency.

Report No.: TMWK2305001496KR

Test Mode:	BLE-2Mbps Mid CH	Temp/Hum	24.3(°C) / 60%RH
Test Item	Harmonic	Test Date	May 30, 2023
Polarize	Vertical	Test Engineer	Czerny Lin
Detector	Peak / Average		

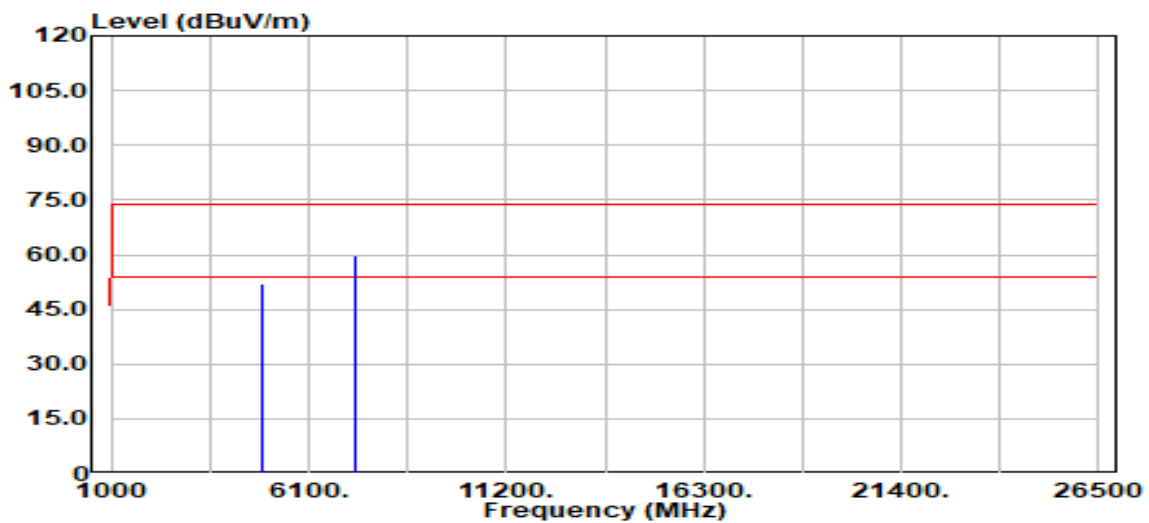

Freq. (MHz)	Detector Mode (PK/QP/AV)	Spectrum Reading Level (dBμV)	Factor (dB)	Actual FS (dBμV/m)	Limit @3m (dBμV/m)	Margin (dB)
4880.00	Peak	51.54	0.48	52.02	74.00	-21.98
4880.00	Average	46.67	0.48	47.15	54.00	-6.85
7320.00	Peak	54.32	5.48	59.81	74.00	-14.19
7320.00	Average	47.55	5.48	53.03	54.00	-0.97
N/A						

Remark:

1. Measuring frequencies from 1 GHz to the 10th harmonic of highest fundamental frequency.

Report No.: TMWK2305001496KR

Test Mode:	BLE-2Mbps Mid CH	Temp/Hum	24.3(°C) / 60%RH
Test Item	Harmonic	Test Date	May 30, 2023
Polarize	Horizontal	Test Engineer	Czerny Lin
Detector	Peak / Average		

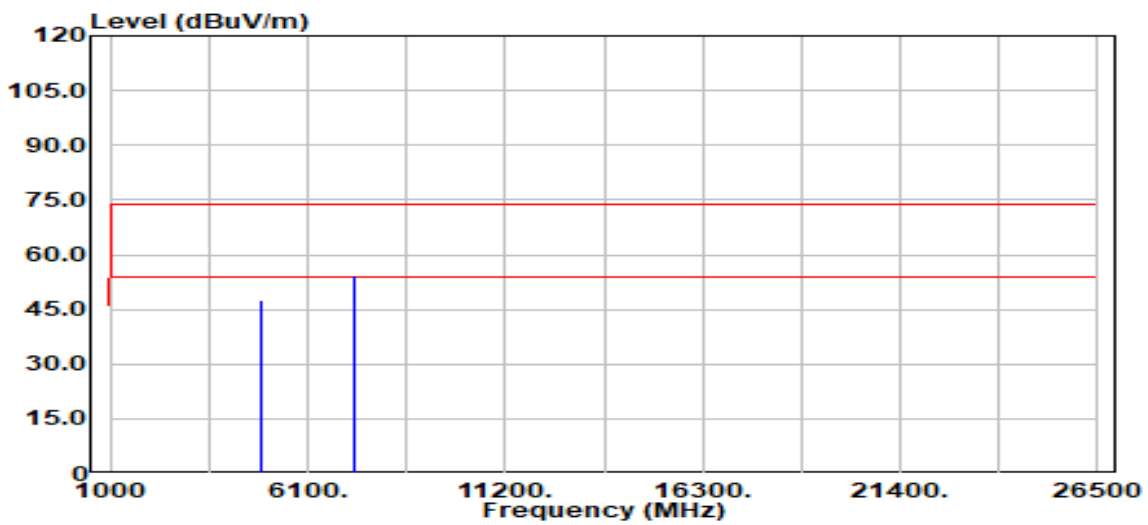

Freq. (MHz)	Detector Mode (PK/QP/AV)	Spectrum Reading Level (dBµV)	Factor (dB)	Actual FS (dBµV/m)	Limit @3m (dBµV/m)	Margin (dB)
4880.00	Peak	46.88	0.48	47.37	74.00	-26.63
4880.00	Average	40.30	0.48	40.78	54.00	-13.22
7320.00	Peak	48.84	5.48	54.32	74.00	-19.68
7320.00	Average	42.29	5.48	47.78	54.00	-6.22
N/A						

Remark:

1. Measuring frequencies from 1 GHz to the 10th harmonic of highest fundamental frequency.

Report No.: TMWK2305001496KR

Test Mode:	BLE-2Mbps High CH	Temp/Hum	24.3(°C) / 60%RH
Test Item	Harmonic	Test Date	May 30, 2023
Polarize	Vertical	Test Engineer	Czerny Lin
Detector	Peak / Average		

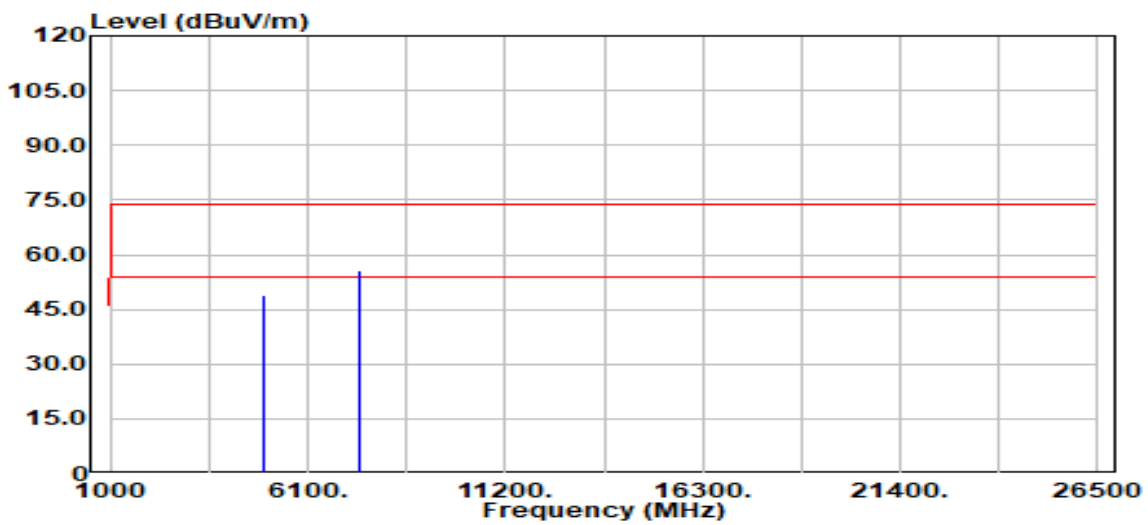

Freq. (MHz)	Detector Mode (PK/QP/AV)	Spectrum Reading Level (dBμV)	Factor (dB)	Actual FS (dBμV/m)	Limit @3m (dBμV/m)	Margin (dB)
4960.00	Peak	48.43	0.65	49.07	74.00	-24.93
4960.00	Average	42.13	0.65	42.77	54.00	-11.23
7440.00	Peak	50.26	5.56	55.82	74.00	-18.18
7440.00	Average	47.67	5.56	53.24	54.00	-0.76
N/A						

Remark:

1. Measuring frequencies from 1 GHz to the 10th harmonic of highest fundamental frequency.

Report No.: TMWK2305001496KR

Test Mode:	BLE-2Mbps High CH	Temp/Hum	24.3(°C) / 60%RH
Test Item	Harmonic	Test Date	May 30, 2023
Polarize	Horizontal	Test Engineer	Czerny Lin
Detector	Peak / Average		

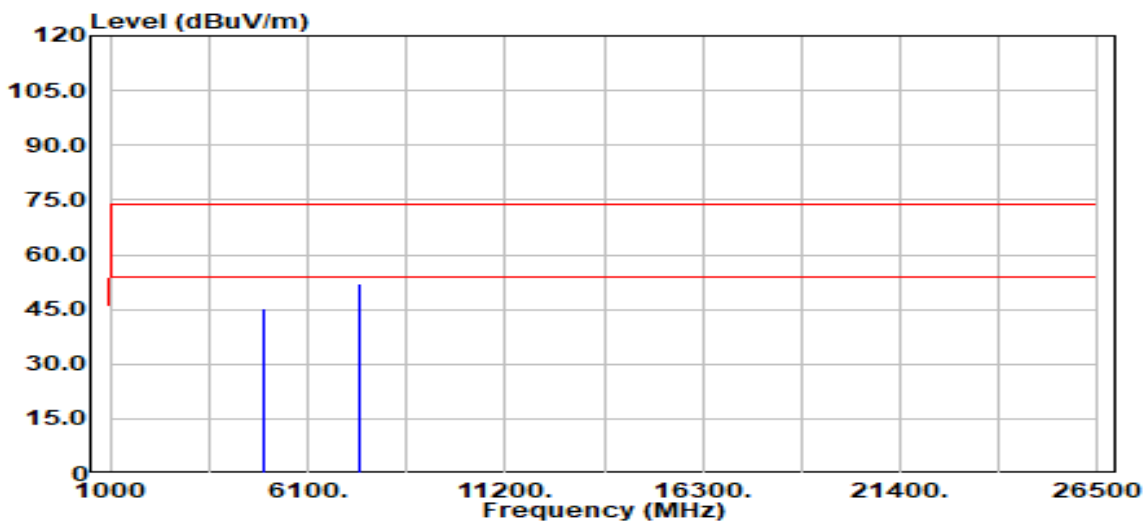

Freq. (MHz)	Detector Mode (PK/QP/AV)	Spectrum Reading Level (dBμV)	Factor (dB)	Actual FS (dBμV/m)	Limit @3m (dBμV/m)	Margin (dB)
4960.00	Peak	44.83	0.65	45.47	74.00	-28.53
4960.00	Average	37.81	0.65	38.46	54.00	-15.54
7440.00	Peak	46.30	5.56	51.86	74.00	-22.14
7440.00	Average	42.81	5.56	48.37	54.00	-5.63
N/A						

Remark:

1. Measuring frequencies from 1 GHz to the 10th harmonic of highest fundamental frequency.

Report No.: TMWK2305001496KR

Test Mode: Mode 2 (PIFA Antenna)

Test Mode:	BLE-1Mbps Low CH	Temp/Hum	25.4(°C) / 57%RH
Test Item	Harmonic	Test Date	June 6, 2023
Polarize	Vertical	Test Engineer	Czerny Lin
Detector	Peak / Average		

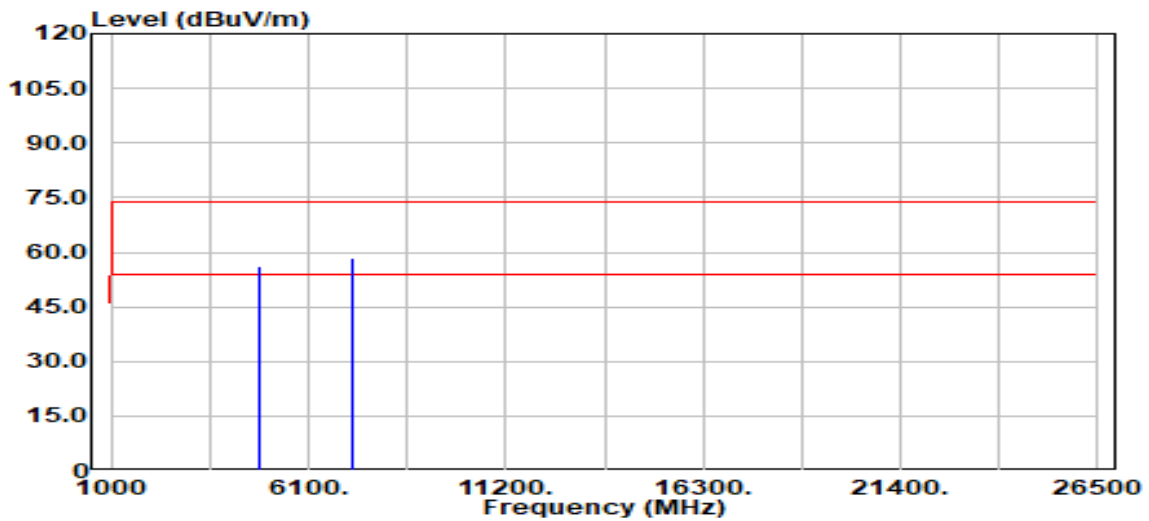

Freq. (MHz)	Detector Mode (PK/QP/AV)	Spectrum Reading Level (dBµV)	Factor (dB)	Actual FS (dBµV/m)	Limit @3m (dBµV/m)	Margin (dB)
4804.00	Peak	55.60	0.38	55.99	74.00	-18.01
4804.00	Average	50.75	0.38	51.13	54.00	-2.87
7206.00	Peak	52.91	5.33	58.23	74.00	-15.77
7206.00	Average	48.03	5.33	53.35	54.00	-0.65
N/A						

Remark:

1. Measuring frequencies from 1 GHz to the 10th harmonic of highest fundamental frequency.

Report No.: TMWK2305001496KR

Test Mode:	BLE-1Mbps Low CH	Temp/Hum	25.4(°C) / 57%RH
Test Item	Harmonic	Test Date	June 6, 2023
Polarize	Horizontal	Test Engineer	Czerny Lin
Detector	Peak / Average		

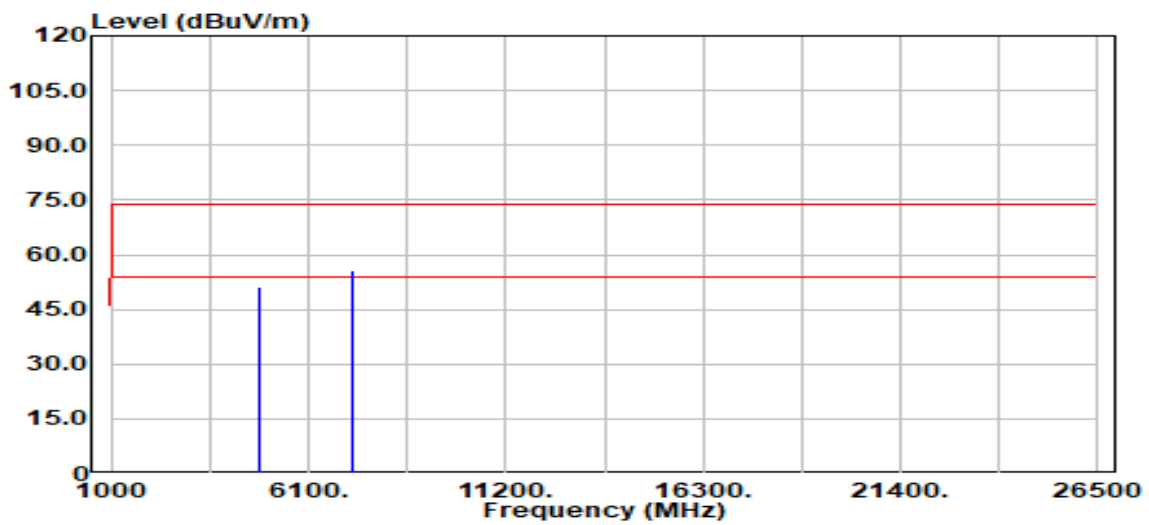

Freq. (MHz)	Detector Mode (PK/QP/AV)	Spectrum Reading Level (dBµV)	Factor (dB)	Actual FS (dBµV/m)	Limit @3m (dBµV/m)	Margin (dB)
4804.00	Peak	50.64	0.38	51.02	74.00	-22.98
4804.00	Average	45.36	0.38	45.74	54.00	-8.26
7206.00	Peak	50.20	5.33	55.52	74.00	-18.48
7206.00	Average	44.89	5.33	50.22	54.00	-3.78
N/A						

Remark:

1. Measuring frequencies from 1 GHz to the 10th harmonic of highest fundamental frequency.

Report No.: TMWK2305001496KR

Test Mode:	BLE-1Mbps Mid CH	Temp/Hum	25.4(°C) / 57%RH
Test Item	Harmonic	Test Date	June 6, 2023
Polarize	Vertical	Test Engineer	Czerny Lin
Detector	Peak / Average		

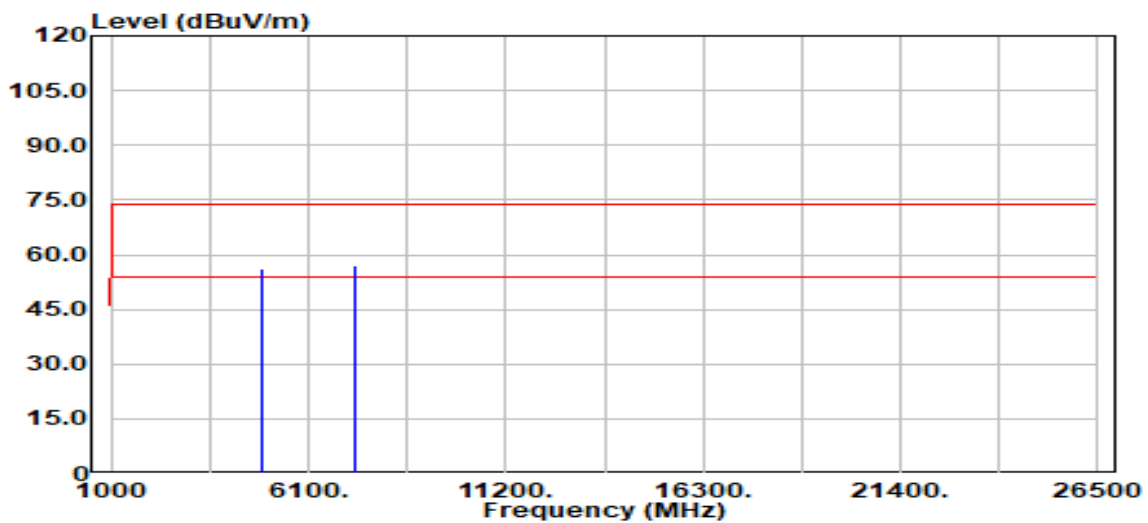

Freq. (MHz)	Detector Mode (PK/QP/AV)	Spectrum Reading Level (dB μ V)	Factor (dB)	Actual FS (dB μ V/m)	Limit @3m (dB μ V/m)	Margin (dB)
4880.00	Peak	55.74	0.48	56.22	74.00	-17.78
4880.00	Average	51.99	0.48	52.48	54.00	-1.52
7320.00	Peak	51.60	5.48	57.08	74.00	-16.92
7320.00	Average	47.25	5.48	52.74	54.00	-1.26
N/A						

Remark:

1. Measuring frequencies from 1 GHz to the 10th harmonic of highest fundamental frequency.

Report No.: TMWK2305001496KR

Test Mode:	BLE-1Mbps Mid CH	Temp/Hum	25.4(°C) / 57%RH
Test Item	Harmonic	Test Date	June 6, 2023
Polarize	Horizontal	Test Engineer	Czerny Lin
Detector	Peak / Average		

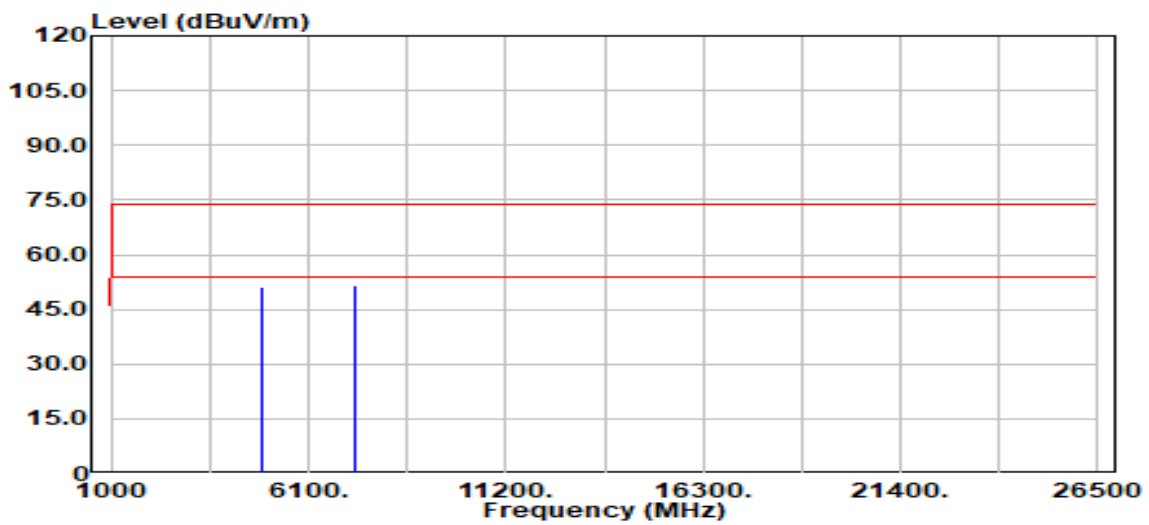

Freq. (MHz)	Detector Mode (PK/QP/AV)	Spectrum Reading Level (dBµV)	Factor (dB)	Actual FS (dBµV/m)	Limit @3m (dBµV/m)	Margin (dB)
4880.00	Peak	50.48	0.48	50.96	74.00	-23.04
4880.00	Average	45.03	0.48	45.52	54.00	-8.48
7320.00	Peak	46.24	5.48	51.73	74.00	-22.28
7320.00	Average	40.36	5.48	45.85	54.00	-8.15
N/A						

Remark:

1. Measuring frequencies from 1 GHz to the 10th harmonic of highest fundamental frequency.

Report No.: TMWK2305001496KR

Test Mode:	BLE-1Mbps High CH	Temp/Hum	25.4(°C) / 57%RH
Test Item	Harmonic	Test Date	June 6, 2023
Polarize	Vertical	Test Engineer	Czerny Lin
Detector	Peak / Average		

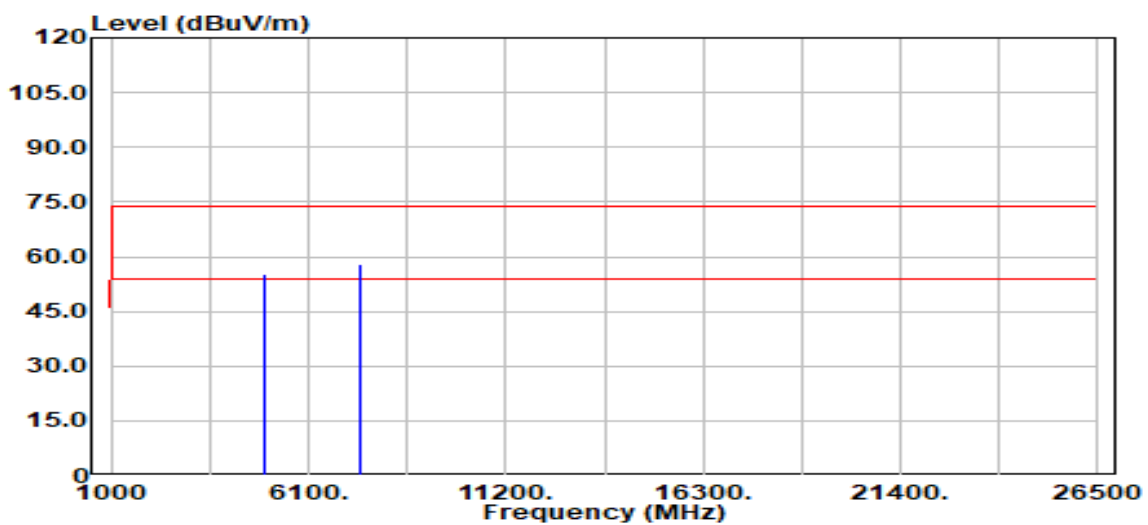

Freq. (MHz)	Detector Mode (PK/QP/AV)	Spectrum Reading Level (dB μ V)	Factor (dB)	Actual FS (dB μ V/m)	Limit @3m (dB μ V/m)	Margin (dB)
4960.00	Peak	54.53	0.65	55.17	74.00	-18.83
4960.00	Average	49.53	0.65	50.17	54.00	-3.83
7440.00	Peak	52.33	5.56	57.89	74.00	-16.11
7440.00	Average	47.63	5.56	53.19	54.00	-0.81
N/A						

Remark:

1. Measuring frequencies from 1 GHz to the 10th harmonic of highest fundamental frequency.

Report No.: TMWK2305001496KR

Test Mode:	BLE-1Mbps High CH	Temp/Hum	25.4(°C) / 57%RH
Test Item	Harmonic	Test Date	June 6, 2023
Polarize	Horizontal	Test Engineer	Czerny Lin
Detector	Peak / Average		

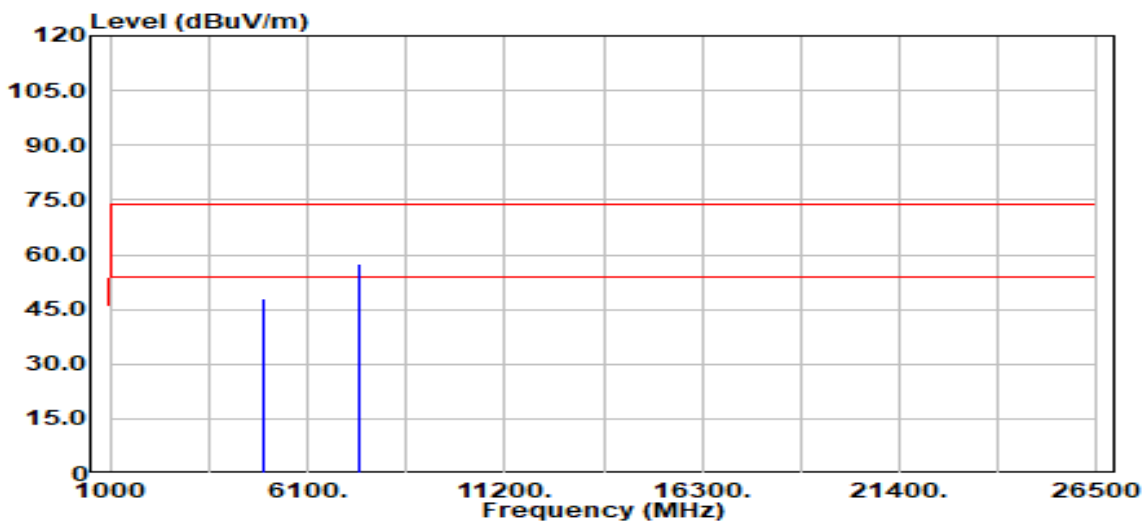

Freq. (MHz)	Detector Mode (PK/QP/AV)	Spectrum Reading Level (dBµV)	Factor (dB)	Actual FS (dBµV/m)	Limit @3m (dBµV/m)	Margin (dB)
4960.00	Peak	47.39	0.65	48.04	74.00	-25.96
4960.00	Average	42.75	0.65	43.39	54.00	-10.61
7440.00	Peak	51.73	5.56	57.29	74.00	-16.71
7440.00	Average	46.31	5.56	51.87	54.00	-2.13
N/A						

Remark:

1. Measuring frequencies from 1 GHz to the 10th harmonic of highest fundamental frequency.

Report No.: TMWK2305001496KR

Test Mode:	BLE-2Mbps Low CH	Temp/Hum	25.4(°C) / 57%RH
Test Item	Harmonic	Test Date	June 6, 2023
Polarize	Vertical	Test Engineer	Czerny Lin
Detector	Peak / Average		

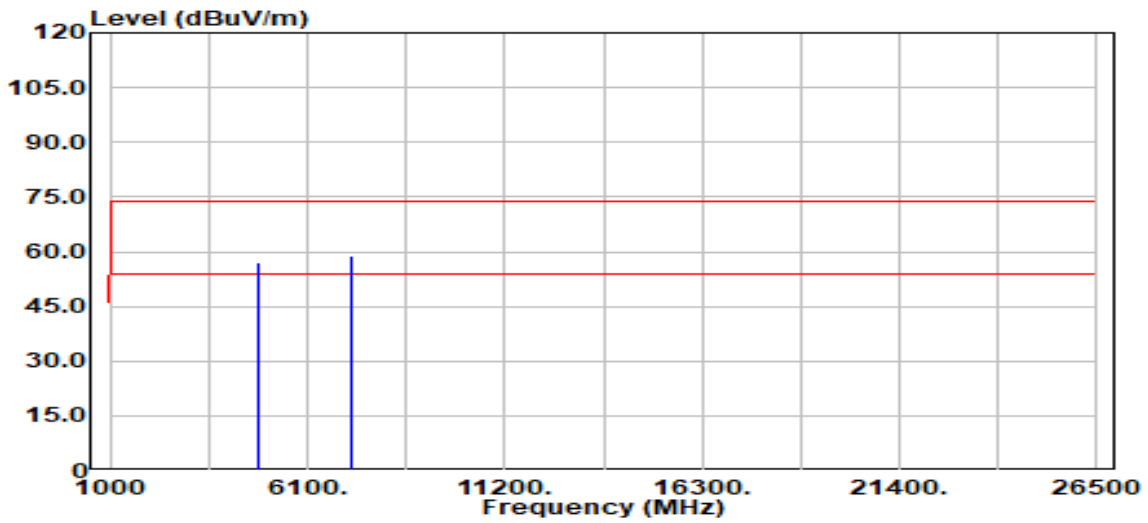

Freq. (MHz)	Detector Mode (PK/QP/AV)	Spectrum Reading Level (dBμV)	Factor (dB)	Actual FS (dBμV/m)	Limit @3m (dBμV/m)	Margin (dB)
4804.00	Peak	56.79	0.38	57.18	74.00	-16.82
4804.00	Average	50.75	0.38	51.13	54.00	-2.87
7206.00	Peak	53.53	5.33	58.86	74.00	-15.14
7206.00	Average	47.27	5.33	52.60	54.00	-1.40
N/A						

Remark:

1. Measuring frequencies from 1 GHz to the 10th harmonic of highest fundamental frequency.

Report No.: TMWK2305001496KR

Test Mode:	BLE-2Mbps Low CH	Temp/Hum	25.4(°C) / 57%RH
Test Item	Harmonic	Test Date	June 6, 2023
Polarize	Horizontal	Test Engineer	Czerny Lin
Detector	Peak / Average		

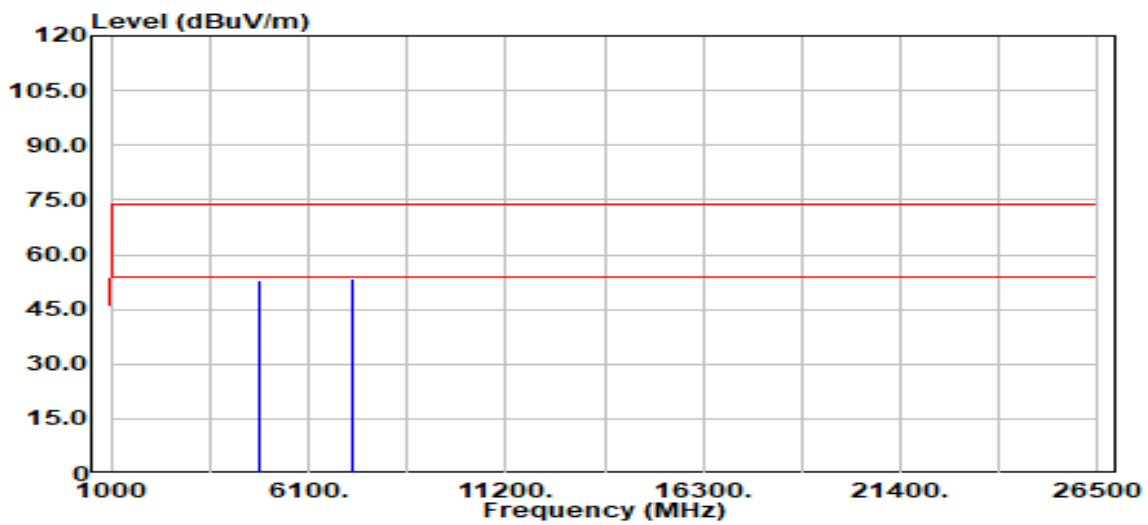

Freq. (MHz)	Detector Mode (PK/QP/AV)	Spectrum Reading Level (dB μ V)	Factor (dB)	Actual FS (dB μ V/m)	Limit @3m (dB μ V/m)	Margin (dB)
4804.00	Peak	52.38	0.38	52.76	74.00	-21.24
4804.00	Average	46.57	0.38	46.96	54.00	-7.04
7206.00	Peak	48.10	5.33	53.43	74.00	-20.57
7206.00	Average	44.30	5.33	49.63	54.00	-4.37
N/A						

Remark:

1. Measuring frequencies from 1 GHz to the 10th harmonic of highest fundamental frequency.

Report No.: TMWK2305001496KR

Test Mode:	BLE-2Mbps Mid CH	Temp/Hum	25.4(°C) / 57%RH
Test Item	Harmonic	Test Date	June 6, 2023
Polarize	Vertical	Test Engineer	Czerny Lin
Detector	Peak / Average		

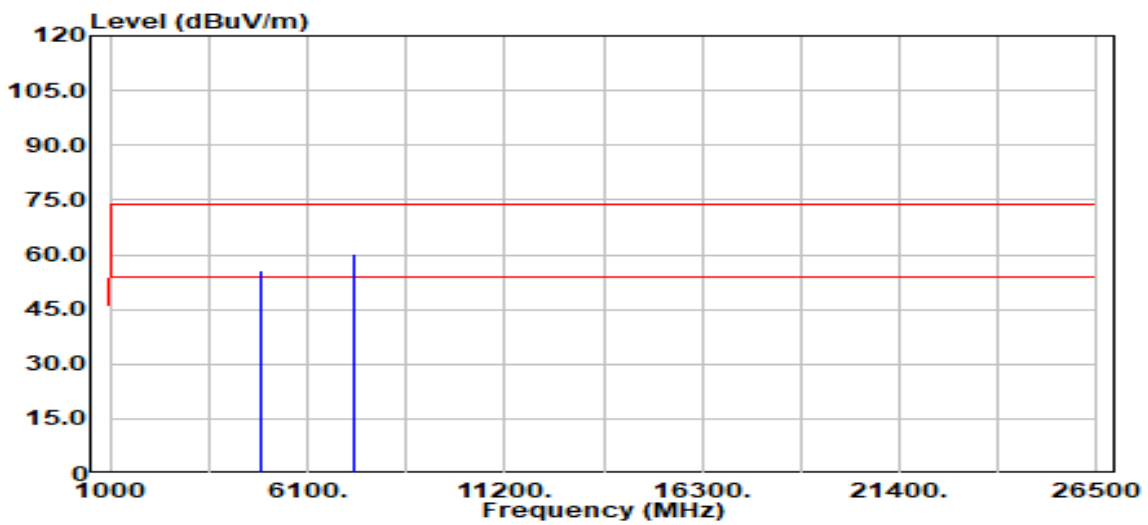

Freq. (MHz)	Detector Mode (PK/QP/AV)	Spectrum Reading Level (dBμV)	Factor (dB)	Actual FS (dBμV/m)	Limit @3m (dBμV/m)	Margin (dB)
4880.00	Peak	55.18	0.48	55.67	74.00	-18.33
4880.00	Average	51.38	0.48	51.86	54.00	-2.14
7320.00	Peak	54.87	5.48	60.35	74.00	-13.65
7320.00	Average	47.44	5.48	52.93	54.00	-1.07
N/A						

Remark:

1. Measuring frequencies from 1 GHz to the 10th harmonic of highest fundamental frequency.

Report No.: TMWK2305001496KR

Test Mode:	BLE-2Mbps Mid CH	Temp/Hum	25.4(°C) / 57%RH
Test Item	Harmonic	Test Date	June 6, 2023
Polarize	Horizontal	Test Engineer	Czerny Lin
Detector	Peak / Average		

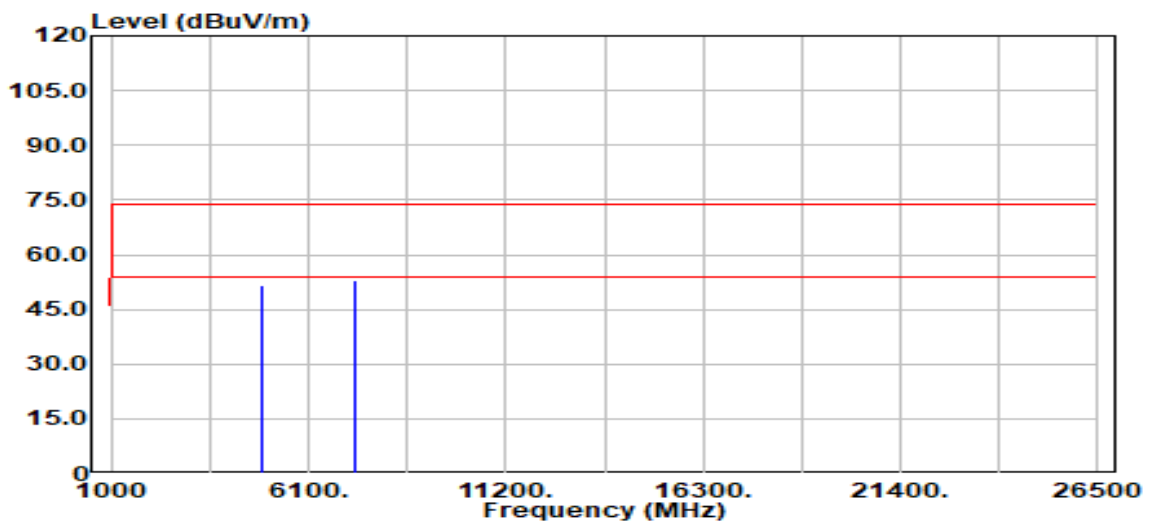

Freq. (MHz)	Detector Mode (PK/QP/AV)	Spectrum Reading Level (dBµV)	Factor (dB)	Actual FS (dBµV/m)	Limit @3m (dBµV/m)	Margin (dB)
4880.00	Peak	51.23	0.48	51.71	74.00	-22.29
4880.00	Average	46.27	0.48	46.75	54.00	-7.25
7320.00	Peak	47.56	5.48	53.04	74.00	-20.96
7320.00	Average	44.70	5.48	50.19	54.00	-3.81
N/A						

Remark:

1. Measuring frequencies from 1 GHz to the 10th harmonic of highest fundamental frequency.

Report No.: TMWK2305001496KR

Test Mode:	BLE-2Mbps High CH	Temp/Hum	25.4(°C) / 57%RH
Test Item	Harmonic	Test Date	June 6, 2023
Polarize	Vertical	Test Engineer	Czerny Lin
Detector	Peak / Average		

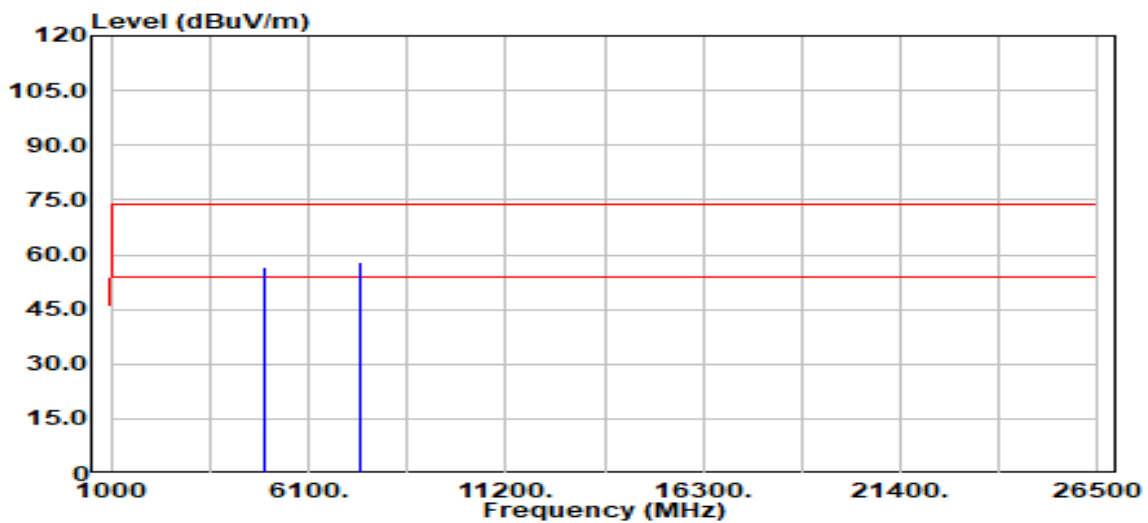

Freq. (MHz)	Detector Mode (PK/QP/AV)	Spectrum Reading Level (dB μ V)	Factor (dB)	Actual FS (dB μ V/m)	Limit @3m (dB μ V/m)	Margin (dB)
4960.00	Peak	55.79	0.65	56.43	74.00	-17.57
4960.00	Average	50.79	0.65	51.44	54.00	-2.56
7440.00	Peak	52.53	5.56	58.09	74.00	-15.91
7440.00	Average	47.53	5.56	53.09	54.00	-0.91
N/A						

Remark:

1. Measuring frequencies from 1 GHz to the 10th harmonic of highest fundamental frequency.

Report No.: TMWK2305001496KR

Test Mode:	BLE-2Mbps High CH	Temp/Hum	25.4(°C) / 57%RH
Test Item	Harmonic	Test Date	June 6, 2023
Polarize	Horizontal	Test Engineer	Czerny Lin
Detector	Peak / Average		

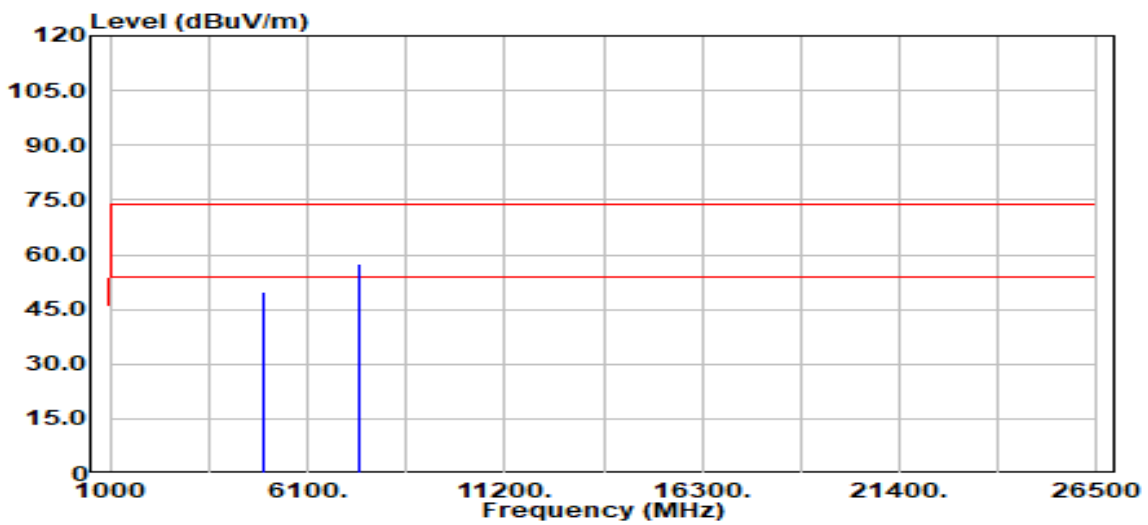

Freq. (MHz)	Detector Mode (PK/QP/AV)	Spectrum Reading Level (dBµV)	Factor (dB)	Actual FS (dBµV/m)	Limit @3m (dBµV/m)	Margin (dB)
4960.00	Peak	49.30	0.65	49.95	74.00	-24.05
4960.00	Average	44.88	0.65	45.53	54.00	-8.47
7440.00	Peak	51.77	5.56	57.33	74.00	-16.67
7440.00	Average	45.79	5.56	51.35	54.00	-2.65
N/A						

Remark:

1. Measuring frequencies from 1 GHz to the 10th harmonic of highest fundamental frequency.

--End of Test Report--