

RF Test Report

Test in accordance with
Federal Communications Commission(FCC)
CFR TITLE 47, Parts 2,22, 24

Product Name: 3G/2G fixed wireless phone

Model No. :F800C

FCC ID: 2AKWZF800C

Applicant : CO-COMM SERVICIOS TELECOMUNICACIONES S.L.
Address : C/Lisboa, 20 – 28232 Las Rozas (Madrid), Spain.

Date of Receipt : 01-05-2017

Test Date :01-05-2017~01-23-2017

Issued Date : 02-07-2017

Report No. :UL47120170105FCC001-2

Report Version :V1.0

Notes:

The test result only relate to these samples which have been tested.
Partly using this report will not be admitted unless been allowed by Unilab.
Unilab is only responsible for the complete report with the reported stamp of Unilab.

Test Report Certification

Issued Date : 12-05-2016
ReportNo. :UL12620161114FCC019-2

Product Name : 3G/2G fixed wireless phone

Applicant : CO-COMM SERVICIOS TELECOMUNICACIONES S.L.

Address : C/Lisboa, 20 – 28232 Las Rozas (Madrid), Spain.

Manufacturer : CO-COMM SERVICIOS TELECOMUNICACIONES S.L.

Address : C/Lisboa, 20 – 28232 Las Rozas (Madrid), Spain.

Model No. : F800C

EUT Voltage : Extreme Low:3.5V Nominal:3.7V Extreme High:4.2V

Brand Name : CO-COMM

Applicable Standard : ANSI/TIA-603-D-2010; FCC KDB 971168D01 Power Meas License Digital
Systems v02r02;FCC CFR Title 47 Part 2;FCCCFR Title 47 Part 22
Subpart ;FCC CFR Title 47 Part24 Subpart E;

Test Result : Complied

Performed Location : Unilab (Shanghai) Co., Ltd.

FCC 2.948 register number is 714465

No. 1350, Lianxi Rd. Pudong New District, Shanghai, China

TEL: +86-21-50275125FAX: +86-21-50275126

Prepared by :



(Technical Engineer: Wayne Wu)

Reviewed by :



(Senior Engineer: Forest Cao)

Approved by :

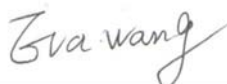

(SupervisorEngineer: Eva Wang)

TABLE OF CONTENTS

SUMMARY OF TEST RESULT	4
1. General Information	5
1.1. EUT Description	5
1.2. Mode of Operation	6
1.3. Tested System Details	7
1.4. Configuration of Tested System.....	8
1.5. EUT Exercise Software	8
2. Technical Test.....	9
2.1. Test Environment	9
3. Peak Output Power	10
3.1. Test Equipment	10
3.2. Test Setup.....	10
3.3. Limit.....	11
3.5. Uncertainty	12
3.6. Test Result	13
4. Occupied Bandwidth	15
4.1. Test Equipment	15
4.2. Test Setup	15
4.3. Limit.....	15
4.4. Test Procedure	15
4.5. Uncertainty	15
4.6. Test Result	16
5. Spurious Emission At Antenna Terminals (+/- 1MHz)	20
5.1. Test Equipment	20
5.2. Test Setup	20
5.3. Limit.....	20
5.4. Test Procedure	20
5.5. Uncertainty	21
5.6. Test Result	21
6. Spurious Emission.....	23
6.1. Test Equipment	23
6.2. Test Setup	24
6.3. Limit.....	25
6.4. Test Procedure	25
6.5. Uncertainty	26
6.6. Test Result	26
7. Frequency Stability Under Temperature & Voltage Variations	32
7.1. Test Equipment	32
7.2. Test Setup	32
7.3. Limit.....	33
7.4. Test Procedure	33
7.5. Uncertainty	33
8. Attachment.....	36

SUMMARY OF TEST RESULT

Report Section	SPECIFICATION	Description	Limit	Result
	FCC CFR 47			
3	part2.1046	Conducted Output Power	N/A	PASS
3	part 22.913(a)(2)	Effective RadiatedPower Equivalent IsotropicRadiated Power	<7 Watts <2 Watts	PASS
4	part 2.1049 part 22.917(a) part 24.238(a)	Occupied Bandwidth	N/A	PASS
5	part 2.1051 part 22.917(a) part 24.238(a)	Band Edge Measurement	<43+10lg(P[Watts])	PASS
6	part 2.1051 part 22.917(a) part 24.238(a)	Conducted Spurious Emission	<43+10lg(P[Watts])	PASS
6	part 2.1053 part 22.917(a) part 24.238(a)	Field Strength of Spurious Radiation	<43+10lg(P[Watts])	PASS
7	part 2.1055 part 22.355 part 24.235	Frequency Stability for Temperature &Voltage	<2.5 ppm	PASS

1.General Information

1.1. EUT Description

Product Name:	3G/2G fixed wireless phone
Model Name:	F800C
Hardware Version:	F800C57v1.0
Software Version:	F800C57v000.1.0
RF Exposure Environment:	Uncontrolled
WCDMA	
Support Band:	WCDMA Band V / WCDMA Band II
Tx FrequencyRange:	WCDMA Band V: 824MHz ~849MHz WCDMA Band II:1.85GHz ~1.91GHz
Rx FrequencyRange:	WCDMA Band V: 869MHz ~894MHz WCDMA Band II:1.93GHz ~1.99GHz
Type of modulation:	WCDMA(UMTS): QPSK
Antenna Type:	Connector
AntennaPeak Gain:	WCDMA Band V: -3.8dB WCDMA Band II:2.9dB

1.2. Mode of Operation

Unilab has verified the construction and function in typical operation. EUT is inlink mode with base station emulator at maximum power level. All the test modes were carried out with the EUT in normal operation, which was shown in this test report is the worst test mode and defined as:

Test Mode		
Band	Radiated TCs	Conducted TCs
WCDMA Band V	RMC 12.2Kbps Link	RMC 12.2Kbps Link

Note:

1. Regards to the frequency band operation: the lowest, middle and highest frequency of channel were selected to perform the test, then shown on this report.
2. The maximum power levels are RMC 12.2Kbps mode for WCDMA Band V and RMC 12.2Kbps mode for WCDMA Band II, only these modes were used for all tests.
3. For the ERP/EIRP and radiated emission test, every axis (X, Y, Z) was verified, and show the worst (Z axis) result in this report.

The conducted power table is as follows:

Conducted Power(dBm)			
Band	WCDMA V		
TX Channel	4132	4182	4233
RX Channel	4357	4407	4458
Frequency (MHz)	826.4	836.4	846.6
RMC 12.2Kbps	23.40	23.57	23.65
HSDPA Subtest-1	23.03	22.97	23.07
HSDPA Subtest-2	23.01	22.96	23.06
HSDPA Subtest-3	22.60	22.56	22.65
HSDPA Subtest-4	22.55	22.48	22.59

Conducted Power(dBm)			
Band	WCDMA II		
TX Channel	9262	9400	9538
RX Channel	9662	9800	9938
Frequency (MHz)	1852	1880	1908
RMC 12.2Kbps	23.11	23.58	22.20
HSDPA Subtest-1	23.06	22.31	22.17
HSDPA Subtest-2	23.04	22.23	22.05
HSDPA Subtest-3	22.63	21.75	21.58
HSDPA Subtest-4	22.57	21.74	21.57

1.3. Tested System Details

The types for all equipments, plus descriptions of all cables used in the tested system (including inserted cards) are:

Product	Manufacturer	Model	Serial No.	Power Cord
RadioCommunicationTester	Agilent	E5515C	GB46581718	N/A

1.4. Configuration of Tested System

Connection Diagram

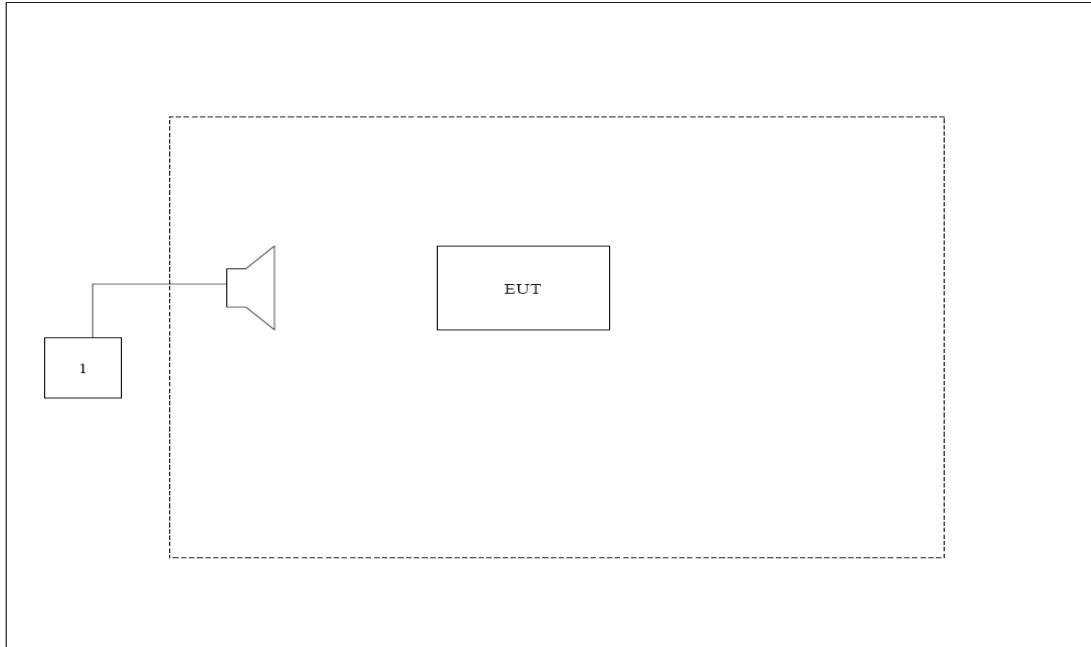

1.5. EUT Exercise Software

1	Setup the EUT and simulators as shown on above.
2	Turn on the power of all equipment.
3	EUT Communicate with Agilent 8960, then select channel to test.

2. Technical Test

2.1. Test Environment

Items	Required (IEC 68-1)	Actual
Temperature (°C)	15-35	22
Humidity (%RH)	25-75	53
Barometric pressure (mbar)	860-1060	950-1000

3. Peak Output Power

3.1. Test Equipment

Instrument	Manufacturer	Model	Serial No.	Cali. Due Date
SpectrumAnalyzer	Agilent	N9038A	MY51210142	11/01/2017
RadioCommunicationTester	Agilent	E5515C	GB46581718	11/03/2017
SignalGenerator	Agilent	N5183A	MY50140938	09/22/2017
Preamplifier	CEM	EM30180	3008A0245	06/07/2017
DC Power Supply	Agilent	6612C	MY43002989	03/01/2018
Bilog Antenna	Schwarzbeck	VULB9160	9160-3316	09/08/2018
VHF-UHF-Biconical Antenna	Schwarzbeck	VUBA9117	9117-263	09/08/2018
Broad-Band Horn Antenna	Schwarzbeck	BBHA9120D	9120D-942	09/08/2018
Broad-Band Horn Antenna	Schwarzbeck	BBHA9120D	9120D-943	09/08/2018

The measureequipment had been calibrated once a year.

3.2. Test Setup

Conducted Power Measurement:

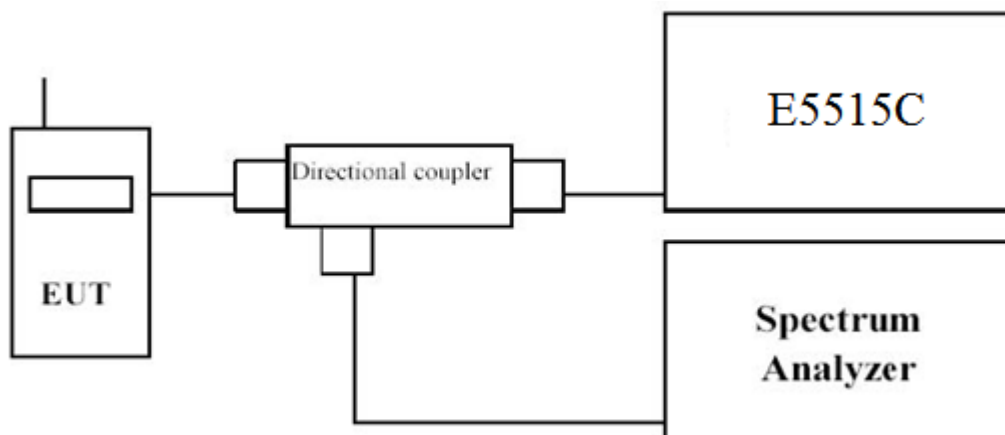

Radiated Spurious Measurement: below 1GHz

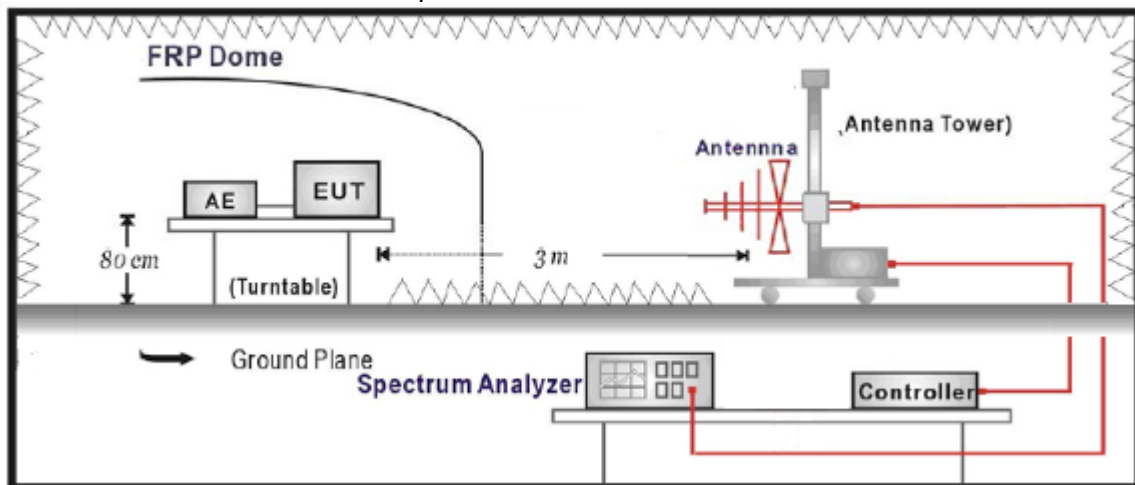

Radiated Spurious Measurement: above 1GHz

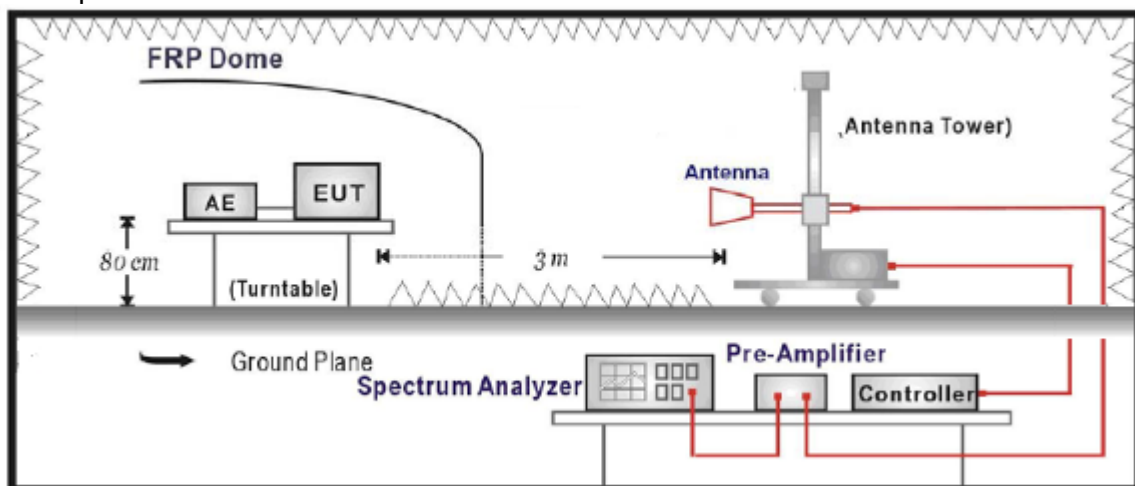

3.3. Limit

For FCC Part 22.913(a)(2):

The ERP of mobile transmitters and auxiliary test transmitters must not exceed 7 Watts.

For FCC Part 24.232(c):

The EIRP of mobile transmitters and auxiliary test transmitters must not exceed 2 Watts.

Conducted Power Measurement:

- a. Place the EUT on a bench and set it in transmitting mode.
- b. Connect a low loss RF cable from the antenna port to a spectrum analyzer and Agilent 8960 by a Directional Couple.
- c. EUT Communicate with Agilent 8960, then selects a channel for testing.
- d. Add a correction factor to the display of spectrum, and then test.

Radiated Power Measurement:

- a. The EUT shall be placed at the specified height on a support, and in the position closest to normal use as declared by provider.
- b. The test antenna shall be oriented initially for vertical polarization and shall be chosen to correspond to the frequency of the transmitter
- c. The output of the test antenna shall be connected to the measuring receiver.
- d. The transmitter shall be switched on and the measuring receiver shall be tuned to the frequency of the transmitter under test.
- e. The test antenna shall be raised and lowered through the specified range of height until a maximum signal level is detected by the measuring receiver.
- f. The transmitter shall then be rotated through 360° in the horizontal plane, until the maximum signal level is detected by the measuring receiver.
- g. The test antenna shall be raised and lowered again through the specified range of height until a maximum signal level is detected by the measuring receiver.
- h. The maximum signal level detected by the measuring receiver shall be noted.
- i. The transmitter shall be replaced by a substitution antenna.
- j. The substitution antenna shall be orientated for vertical polarization and the length of the substitution antenna shall be adjusted to correspond to the frequency of the transmitter.
- k. The substitution antenna shall be connected to a calibrated signal generator.
- l. If necessary, the input attenuator setting of the measuring receiver shall be adjusted in order to increase the sensitivity of the measuring receiver.
- m. The test antenna shall be raised and lowered through the specified range of height to ensure that the maximum signal is received.
- n. The input signal to the substitution antenna shall be adjusted to the level that produces a level detected by the measuring receiver, that is equal to the level noted while the transmitter radiated power was measured, corrected for the change of input attenuator setting of the measuring receiver.
- o. The measurement shall be repeated with the test antenna and the substitution antenna orientated for horizontal polarization.
- p. The measure of the effective radiated power is the larger of the two levels recorded at the input to the substitution antenna, corrected for gain of the substitution antenna if necessary.
- q. Test site anechoic chamber refer to ANSI C63.4: 2014.

3.5. Uncertainty

The measurement uncertainty is defined as for Conducted Power Measurement ± 1.1 dB,
for Radiated Power Measurement ± 3.1 dB

3.6. Test Result

The following table shows the conducted power measured:

Table 1

WCDMA				
Modes	Channel	Frequency (MHz)	Conducted Power (dBm)	Conducted Power (W)
WCDMA Band V	4357(Low)	826.4	23.40	0.22
	4407(Mid)	836.4	23.57	0.23
	4458(High)	846.6	23.65	0.23

Table 2

WCDMAII				
Modes	Channel	Frequency (MHz)	Conducted Power (dBm)	Conducted Power (W)
WCDMA Band II	9662(Low)	1852	23.11	0.20
	9800(Mid)	1880	23.58	0.23
	9938(High)	1908	22.20	0.17

The following table shows the Radiated power measured :

WCDMA Band V

Frequency(MHz)	Ant. Pol. (H/V)	SG Reading(dBm)	Cable Loss(dB)	Gain (dBd)	ERP (dBm)	ERP (W)
Low Channel4357(826.4MHz)						
826.4	H	30.80	3.83	-2.99	23.98	0.25
826.4	V	30.72	3.83	-2.99	23.73	0.25
Middle Channel 4407 (836.4MHz)						
836.4	H	30.47	3.96	-3.04	23.47	0.22
836.4	V	30.66	3.96	-3.04	23.66	0.23
High Channel 4458 (846.6MHz)						
846.6	H	30.59	3.97	-3.10	23.52	0.23
846.6	V	31.01	3.97	-3.10	24.04	0.25

WCDMA BandII

Frequency(MHz)	Ant. Pol. (H/V)	SG Reading(dBm)	Cable Loss(dB)	Gain (dBd)	ERP (dBm)	ERP (W)
Low Channel4357(826.4MHz)						
1852	H	31.02	3.83	-2.99	24.20	0.26
1852	V	30.92	3.83	-2.99	24.10	0.26
Middle Channel 4407 (836.4MHz)						
1880	H	30.66	3.96	-3.04	23.66	0.23
1880	V	30.91	3.96	-3.04	23.91	0.25
High Channel 4458 (846.6MHz)						
1908	H	30.65	3.97	-3.10	23.65	0.23
1908	V	31.74	3.97	-3.10	23.74	0.24

4. Occupied Bandwidth

4.1. Test Equipment

Occupied Bandwidth

Instrument	Manufacturer	Model	Serial No	Cali. Due Date
RadioCommunicationTester	Agilent	E5515C	GB46581718	11/03/2017
SpectrumAnalyzer	Agilent	N9038A	MY51210142	11/01/2017
DC Power Supply	Agilent	6612C	MY43002989	06/07/2017

The measure equipment had been calibrated once a year.

4.2. Test Setup

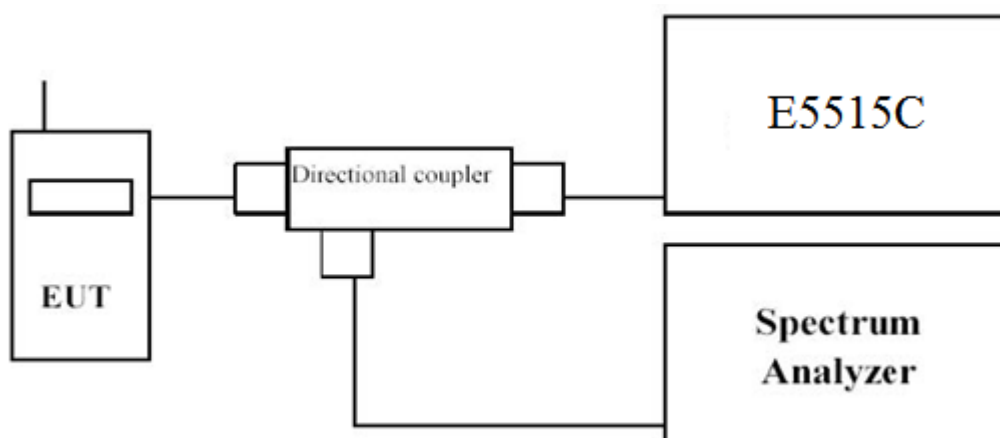

4.3. Limit

N/A

4.4. Test Procedure

1. The testing follows FCC KDB 971168 v02v02 Section 4.2;
2. Using Occupied Bandwidth measurement function of spectrum analyzer. In the Occupied Bandwidth measurement a resolution bandwidth of at least one percent of the emission bandwidth of the fundamental emission of the transmitter may be employed.

4.5. Uncertainty

The measurement uncertainty is defined as ± 10 Hz

4.6. Test Result

WCDMA Band V

Channel No.	Frequency (MHz)	-26dB Occupied Bandwidth (MHz)	99% Occupied Bandwidth (MHz)
4357	826.40	4.682	4.1520
4407	836.40	4.686	4.1634
4458	846.40	4.672	4.1583

WCDMA Band II

Channel No.	Frequency (MHz)	-26dB Occupied Bandwidth (MHz)	99% Occupied Bandwidth (MHz)
9662	1852	4.685	4.1596
9800	1880	4.695	4.1718
9938	1908	4.696	4.1613

WCDMA Band V, Channel 4357

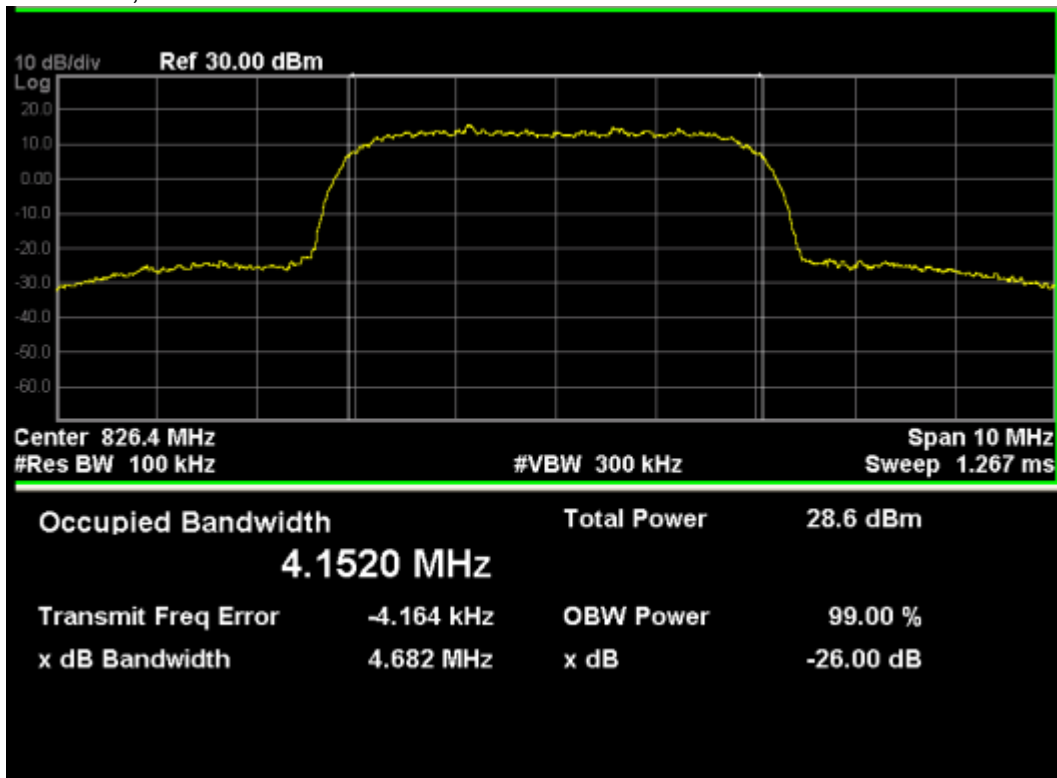

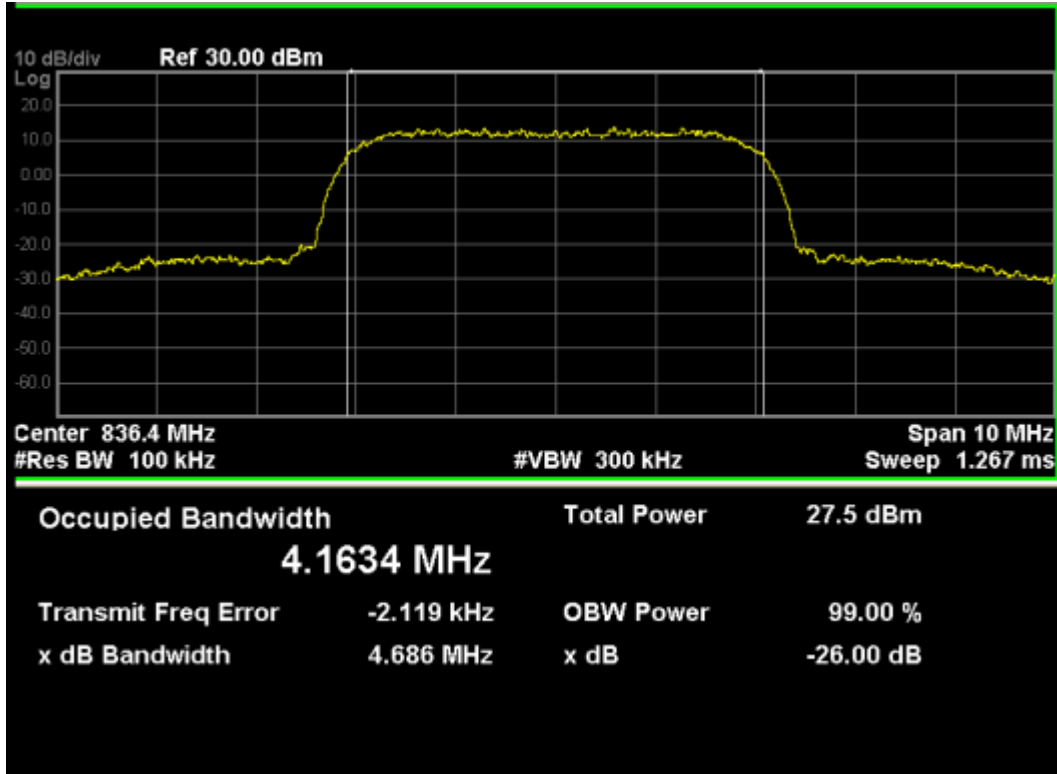

WCDMA Band V, Channel 4458

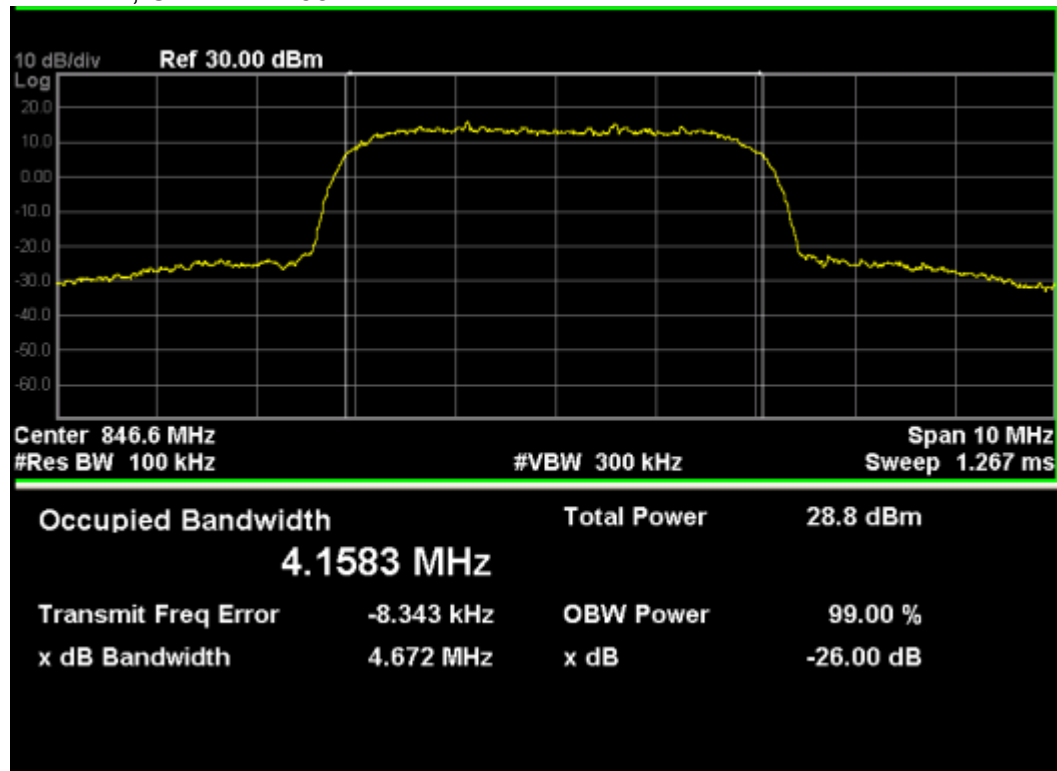

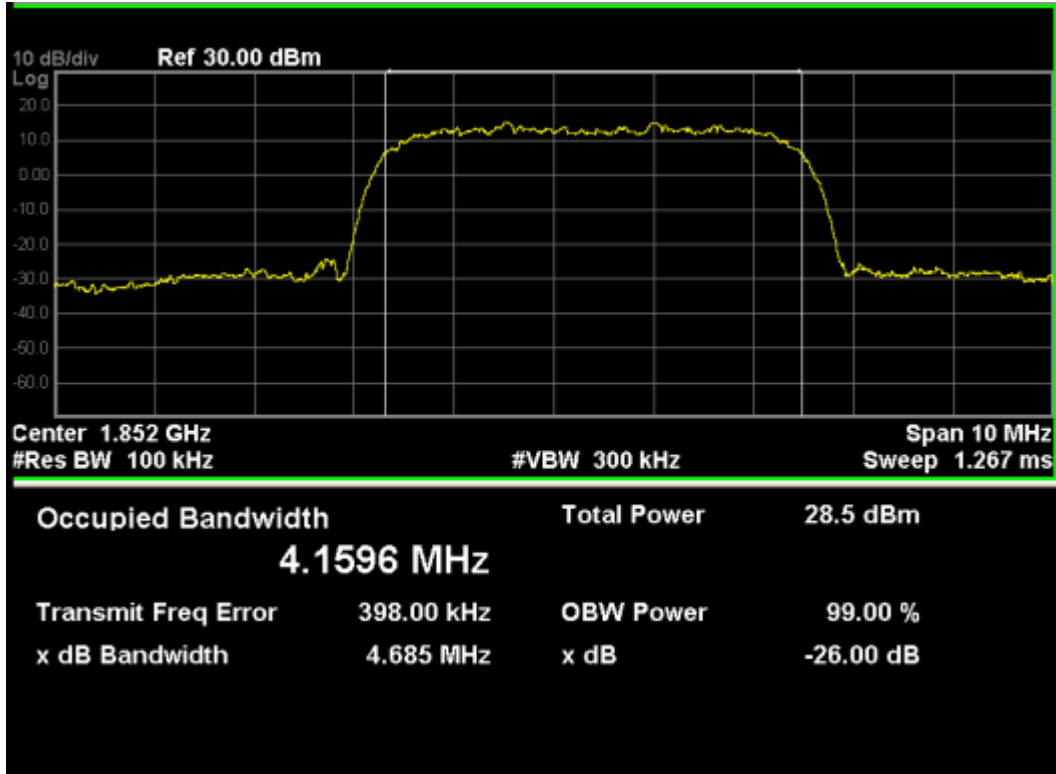

WCDMA Band II, Channel 9800

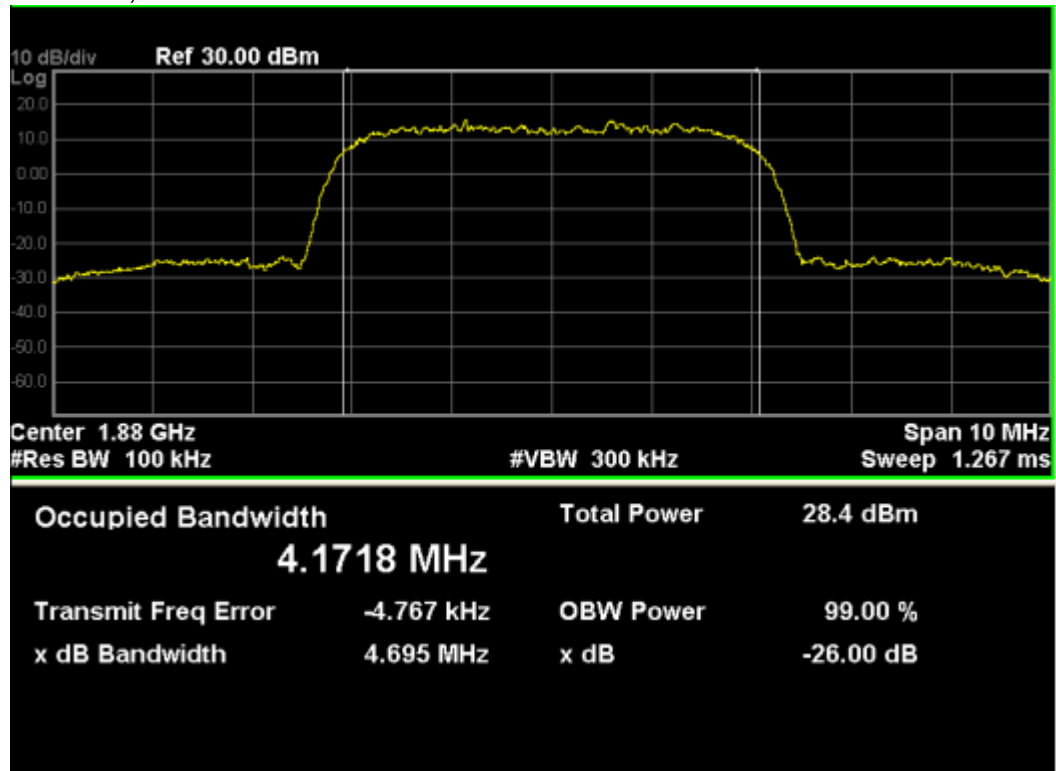

WCDMA Band II, Channel 9938

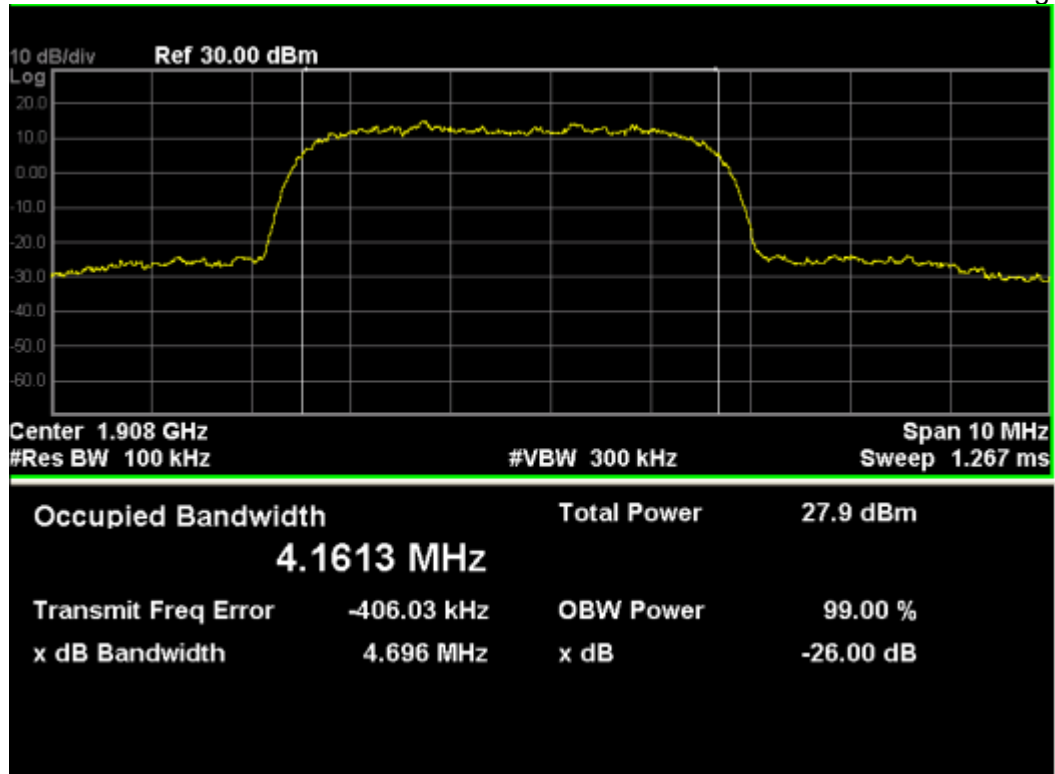

5.Spurious Emission At Antenna Terminals (+/- 1MHz)

5.1. Test Equipment

Instrument	Manufacturer	Model	Serial No	Cali. Due Date
RadioCommunicationTester	Agilent	E5515C	GB46581718	11/03/2017
SpectrumAnalyzer	Agilent	N9038A	MY51210142	11/01/2017
DC Power Supply	Agilent	6612C	MY43002989	06/07/2017

The measure equipment had been calibrated once a year.

5.2. Test Setup

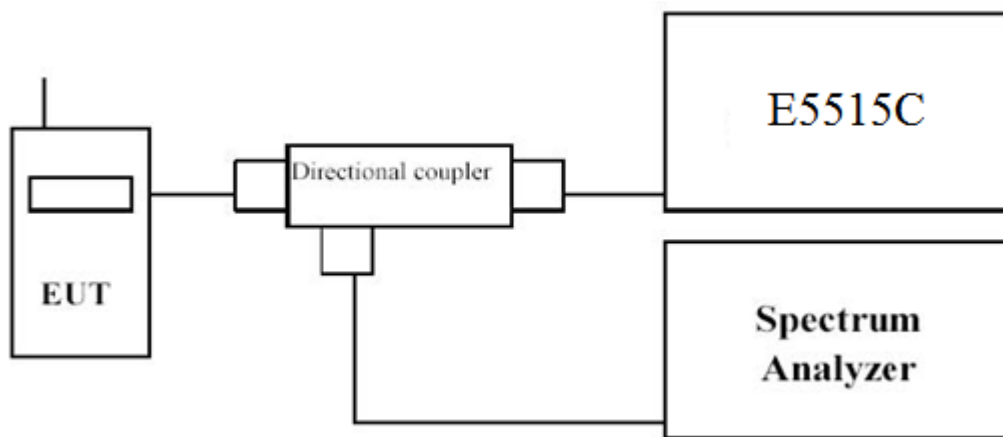

5.3. Limit

The power of any emission outside of the authorized operating frequency ranges must be attenuated below the transmitting power (P) by a factor of at least $43 + 10\log(P)$ dB.

5.4. Test Procedure

In the 1MHz bands immediately outside and adjacent to the frequency block a resolution bandwidth of at least one percent of the emission bandwidth of the fundamental emission of the transmitter may be employed to measure the out of band Emissions.

Procedure:

1. The testing follows FCC KDB 971168 v02v02 Section 6.0;
2. The EUT was connected to spectrum analyzer and the Agilent 8960;
3. The band edges of low and high channels for the highest RF powers were measured. Set $RBW \geq 1\%OBW$ in the 1MHz band immediately outside and adjacent to the band edge.
4. Set spectrum analyzer with RMS detector.

The measurement uncertainty is defined as ± 1.2 dB.

5.6. Test Result

WCDMA Band V, Channel 4357

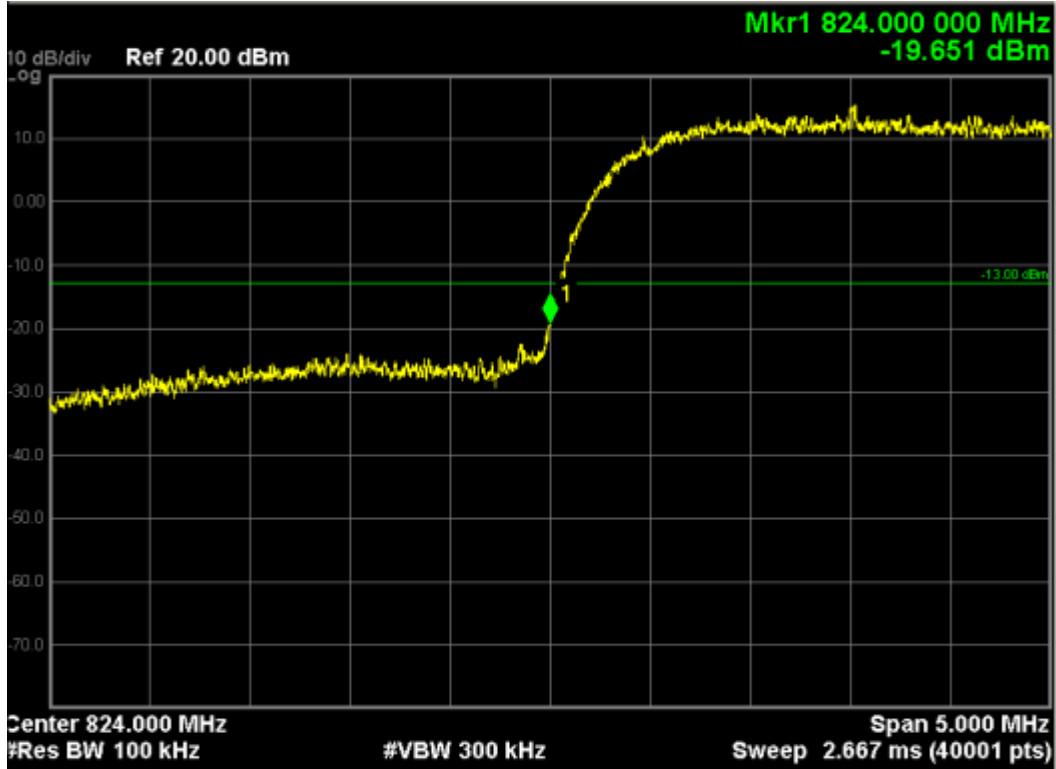

WCDMA Band V, Channel 4458

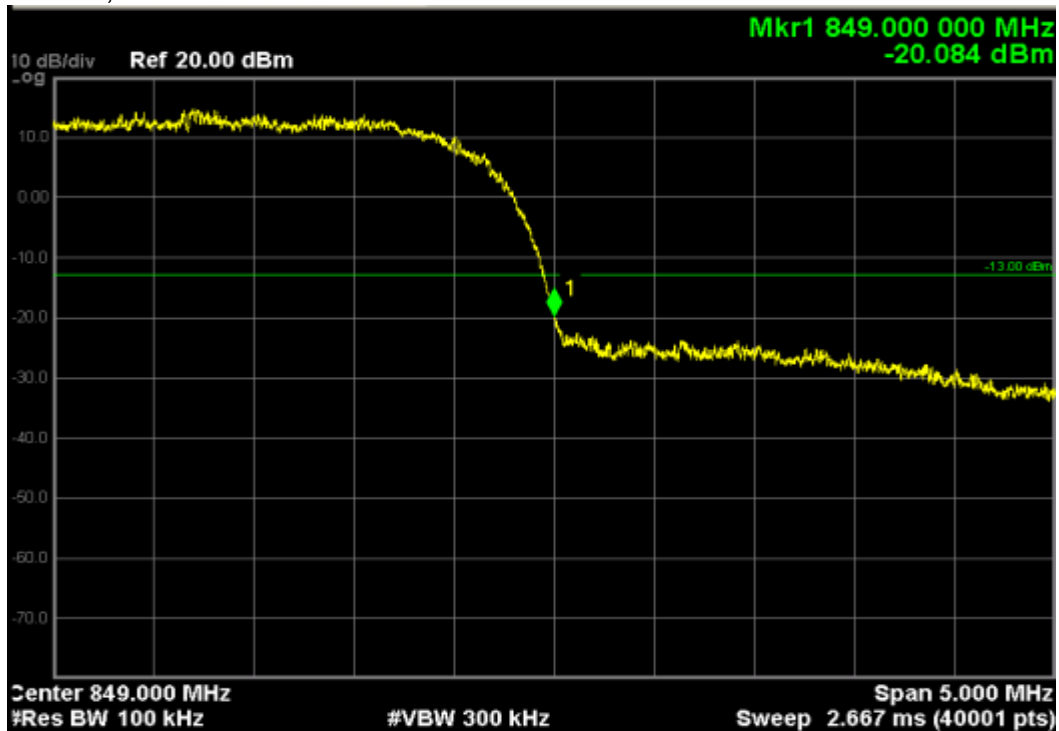

WCDMA Band II, Channel 9662

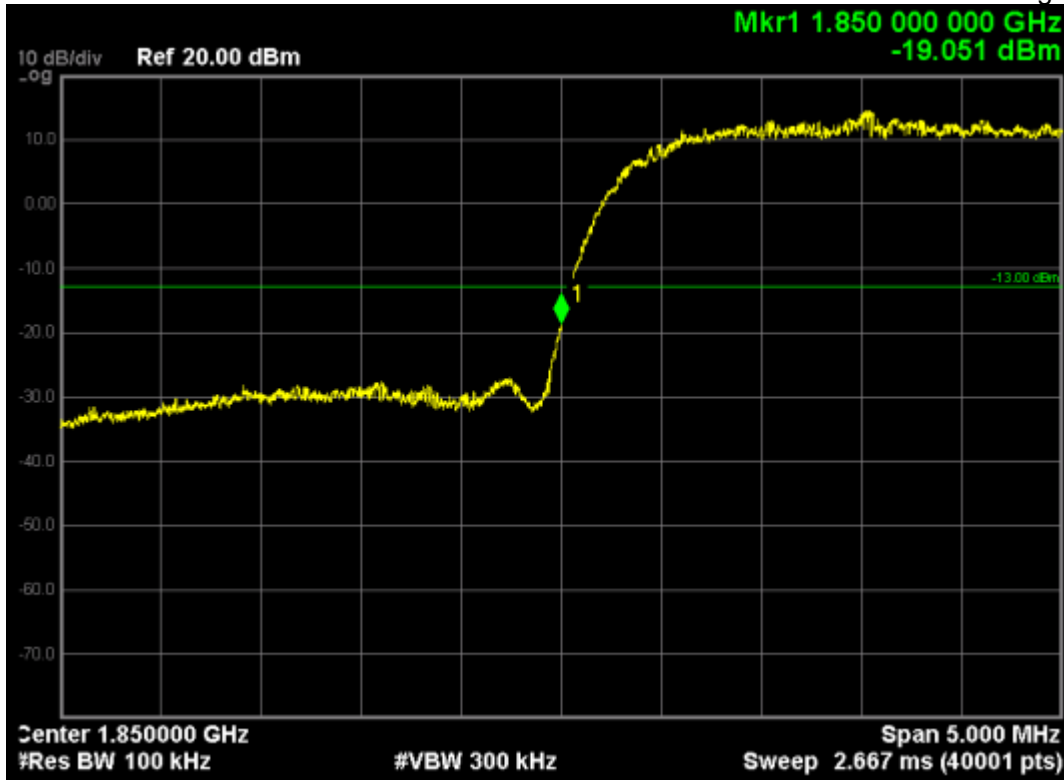

WCDMA Band II, Channel 9938

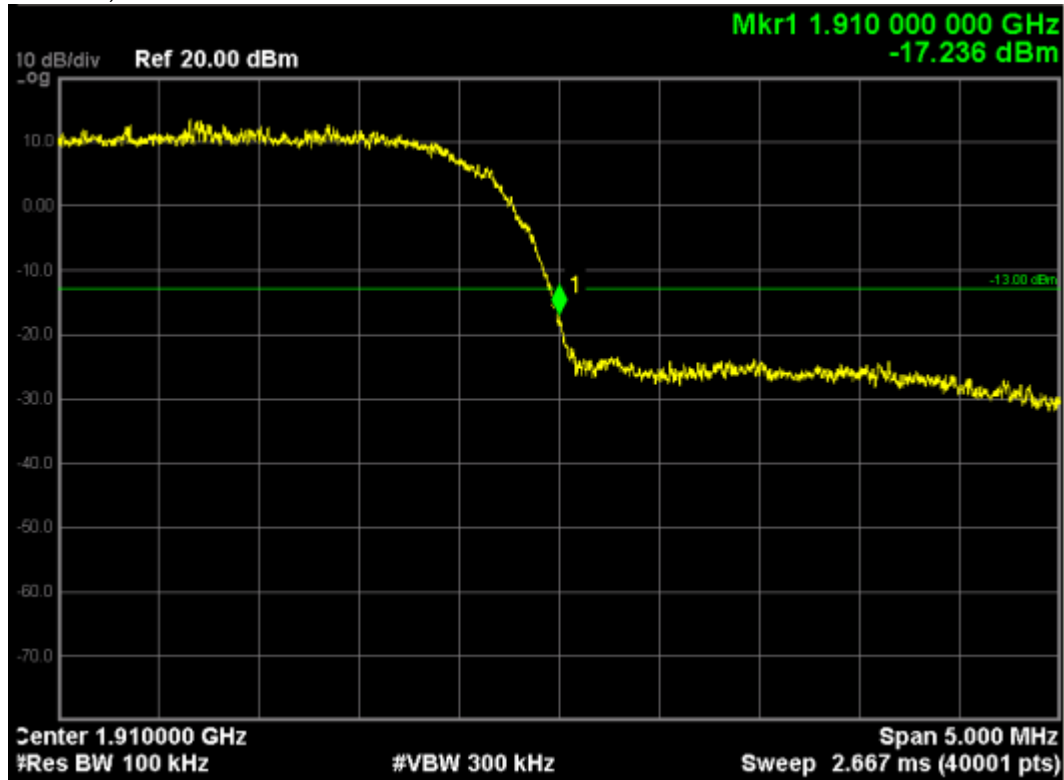

6.Spurious Emission

6.1. Test Equipment

Instrument	Manufacturer	Model	Serial No.	Cali. Due Date
SpectrumAnalyzer	Agilent	N9038A	MY51210142	11/01/2017
RadioCommunicationTester	Agilent	E5515C	GB46581718	11/03/2017
SignalGenerator	Agilent	N5183A	MY50140938	01/02/2018
Preamplifier	CEM	EM30180	3008A0245	06/07/2017
Loop Antenna	Schwarzbeck	FMZB1519	1519-020	03/23/2018
Bilog Antenna	Schwarzbeck	VULB9160	9160-3316	09/08/2018
VHF-UHF-Biconical Antenna	Schwarzbeck	VUBA9117	9117-263	09/08/2018
Broad-Band Horn Antenna	Schwarzbeck	BBHA9120D	9120D-942	09/08/2018
Broad-Band Horn Antenna	Schwarzbeck	BBHA9120D	9120D-943	09/08/2018

The measure equipment had been calibrated once a year.

6.2. Test Setup

Conducted Spurious Emission Measurement:

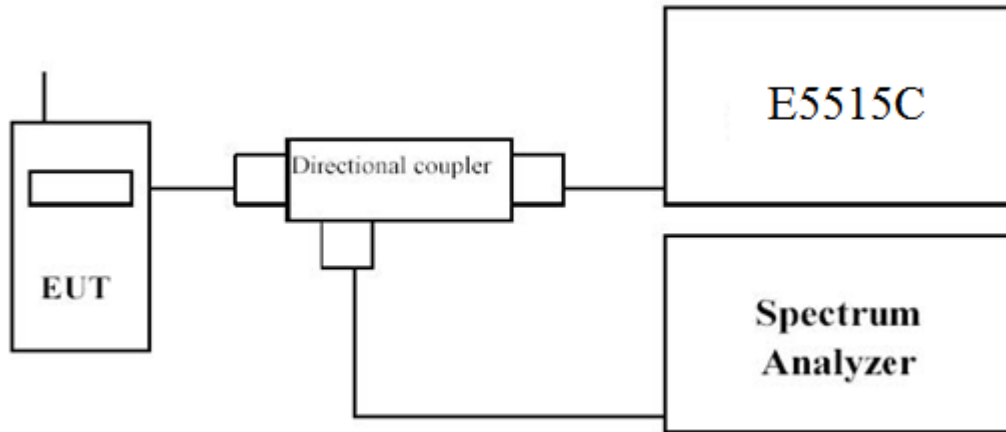

Radiated Spurious Measurement: below 30MHz

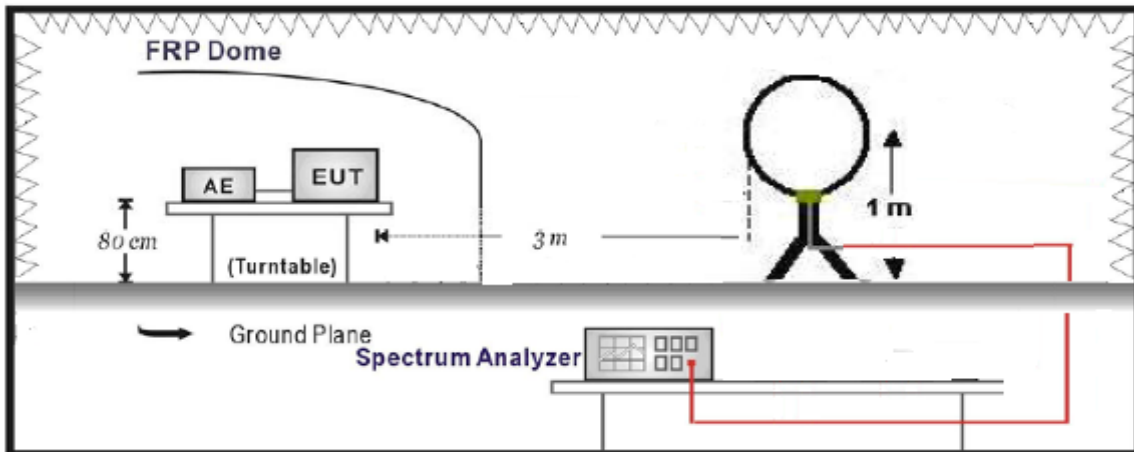

Radiated Spurious Measurement: 30MHz to 1GHz

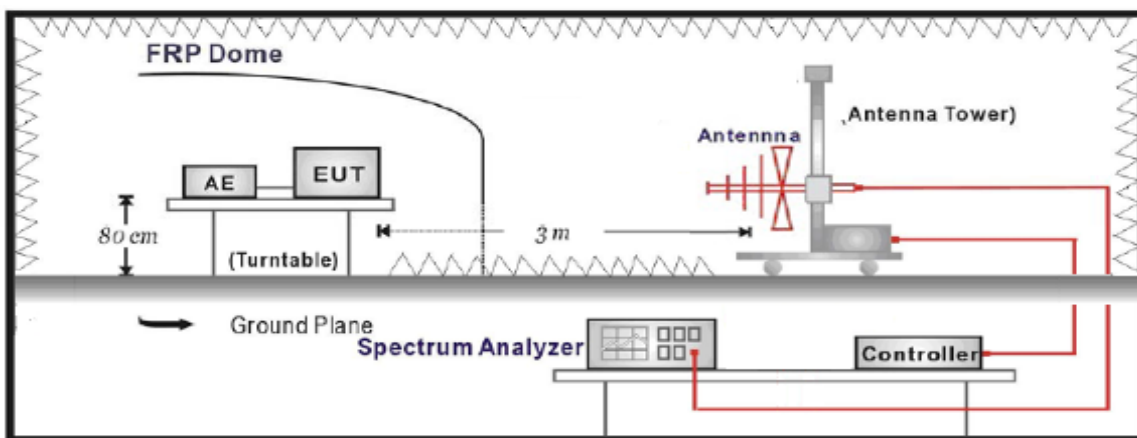

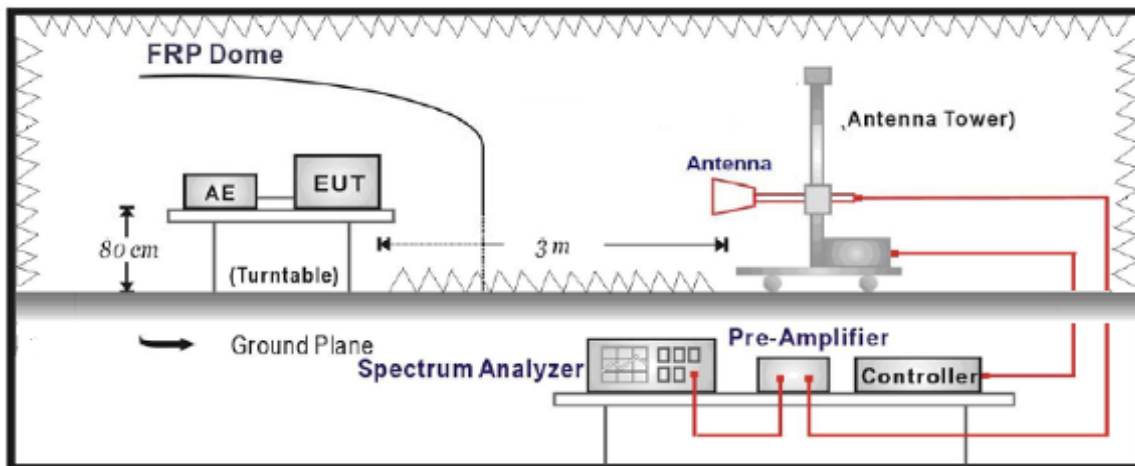

6.3. Limit

The power of any emission outside of the authorized operating frequency ranges must be attenuated below the transmitting power (P) by a factor of at least $43 + 10\log(P)$ dB.

6.4. Test Procedure

Conducted Spurious Measurement:

- The testing follows FCC KDB 971168 v02v02 Section 6.0;
- Place the EUT on a bench and set it in transmitting mode.
- Connect a low loss RF cable from the antenna port to a spectrum analyzer and Agilent 8960 by a Directional Coupler.
- EUT Communicate with Agilent 8960, then select a channel for testing.
- Add a correction factor to the display of spectrum, and then test.
- The resolution bandwidth of the spectrum analyzer was set at 1 MHz, sufficient scans were taken to show the out of band Emission if any up to 10th harmonic.

Radiated Spurious Measurement:

- The testing follows FCC KDB 971168 v02v02 Section 5.8 and ANSI/TIA-603-D-2010 Section 2.2.12;
- The EUT shall be placed at the specified height on a support, and in the position closest to normal use as declared by provider.
- The test antenna shall be oriented initially for vertical polarization and shall be chosen to correspond to the frequency of the transmitter
- The output of the test antenna shall be connected to the measuring receiver. The transmitter shall be switched on and the measuring receiver shall be tuned to the frequency of the transmitter under test.
- The test antenna shall be raised and lowered through the specified range of height until a maximum signal level is detected by the measuring receiver.
- The transmitter shall then be rotated through 360° in the horizontal plane, until the maximum signal level is detected by the measuring receiver.
- The test antenna shall be raised and lowered again through the specified range of height until a maximum signal level is detected by the measuring receiver.

- h. The maximum signal level detected by the measuring receiver shall be noted.
- i. The transmitter shall be replaced by a substitution antenna.
- j. The substitution antenna shall be orientated for vertical polarization and the length of the substitution antenna shall be adjusted to correspond to the frequency of the transmitter.
- k. The substitution antenna shall be connected to a calibrated signal generator.
- l. If necessary, the input attenuator setting of the measuring receiver shall be adjusted in order to increase the sensitivity of the measuring receiver.
- m. The test antenna shall be raised and lowered through the specified range of height to ensure that the maximum signal is received.
- n. The input signal to the substitution antenna shall be adjusted to the level that produces a level detected by the measuring receiver, that is equal to the level noted while the transmitter radiated power was measured, corrected for the change of input attenuator setting of the measuring receiver.
- o. The measurement shall be repeated with the test antenna and the substitution antenna orientated for horizontal polarization.
- p. The measure of the effective radiated power is the larger of the two levels recorded at the input to the substitution antenna, corrected for gain of the substitution antenna if necessary.
- q. The frequency range was checked up to 10th harmonic.

6.5. Uncertainty

The measurement uncertainty is defined as 3.2 dB for Radiated Power Measurement.

6.6. Test Result

Conducted Spurious Measurement:

WCDMA Band V, Channel 4407:

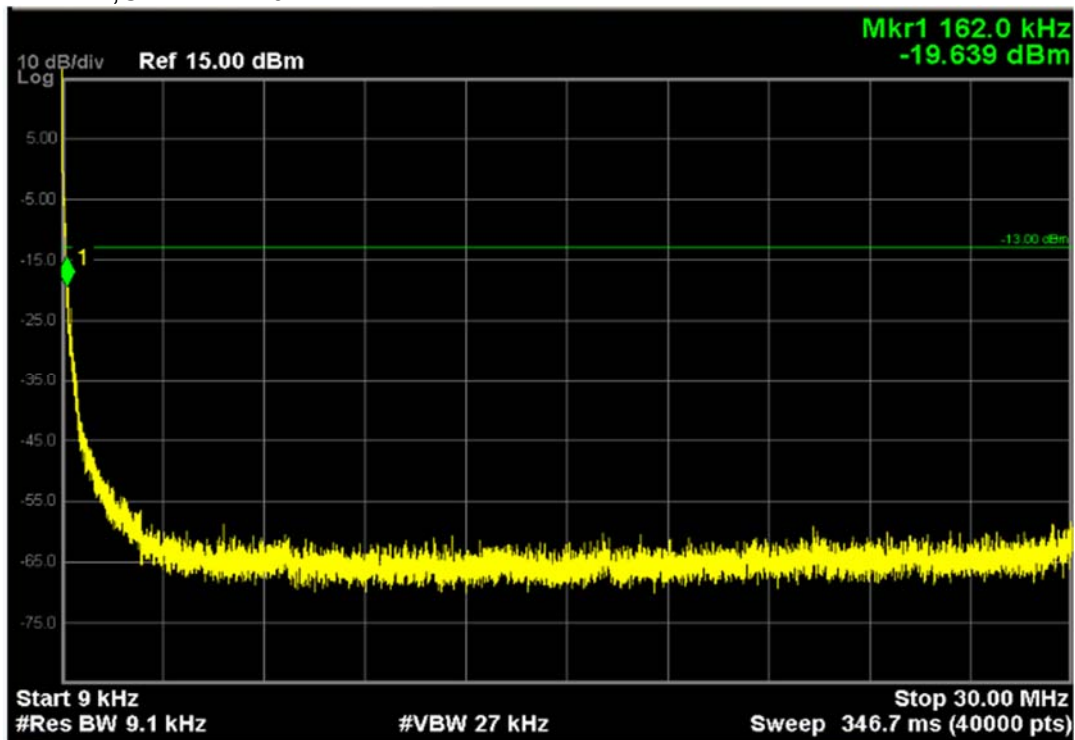

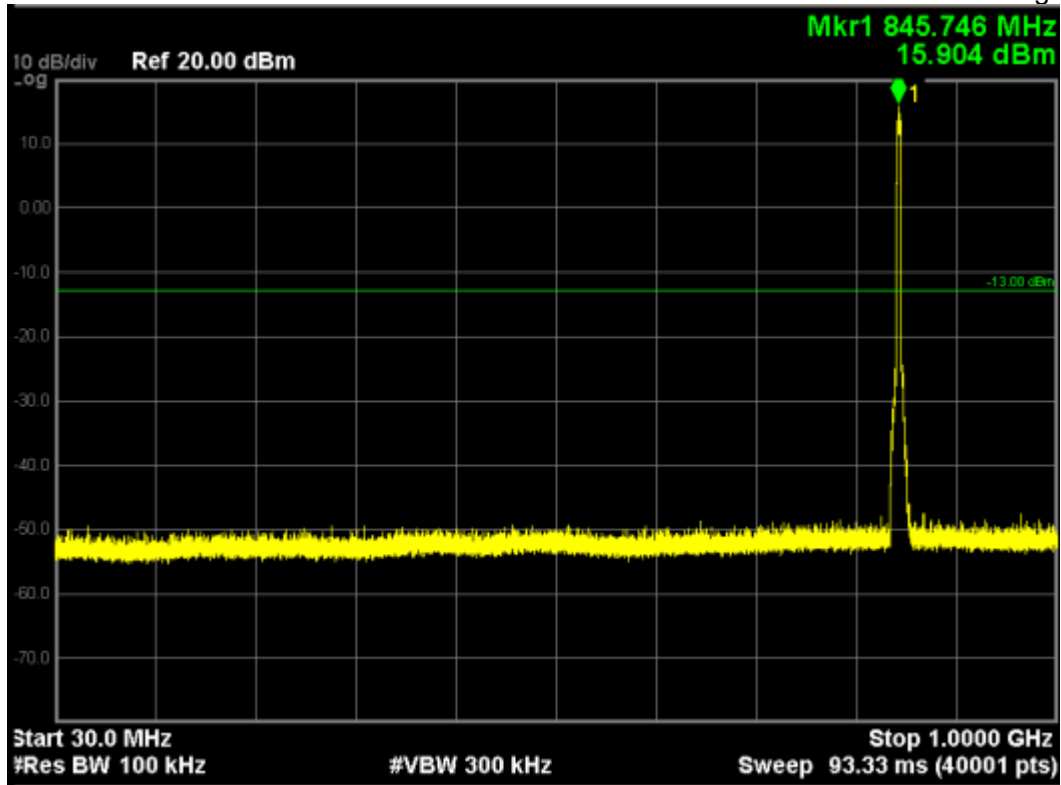

Note: The signal at point 1 is carrier

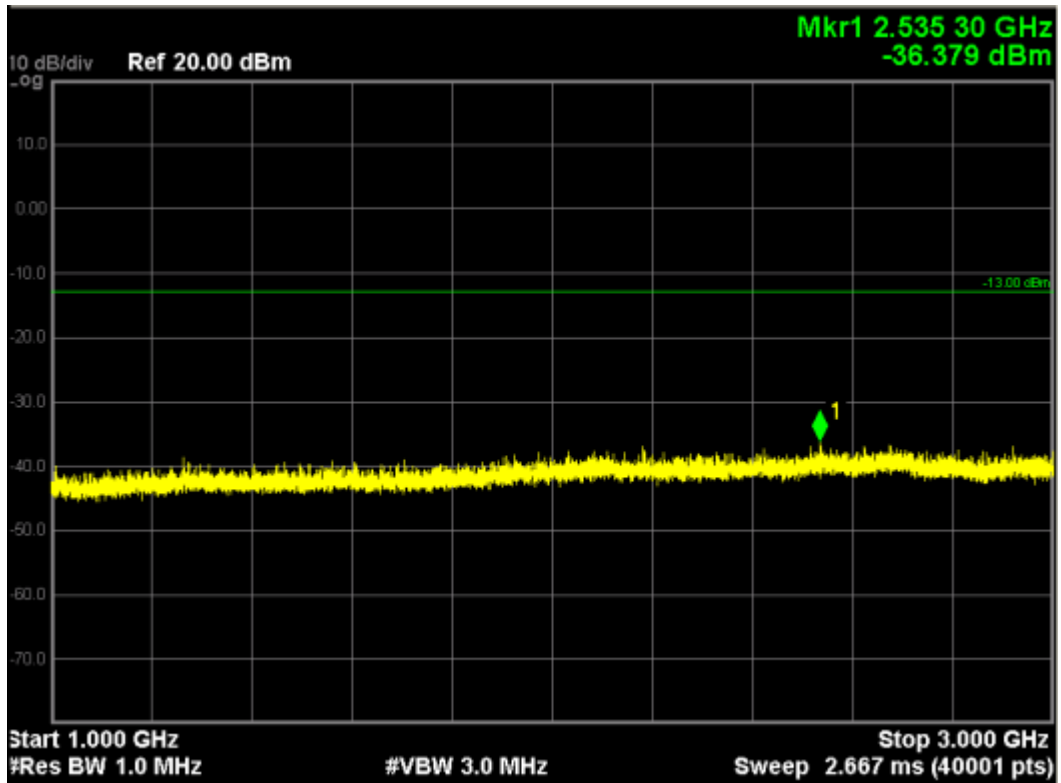

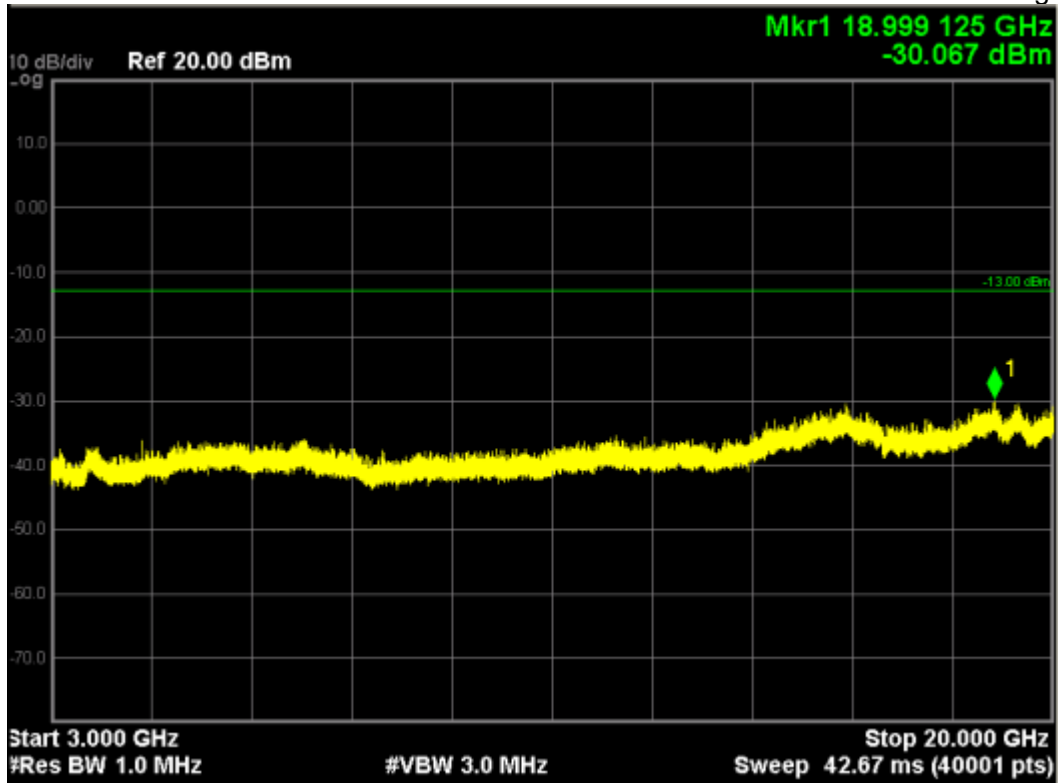

WCDMA Band II, Channel 9800:

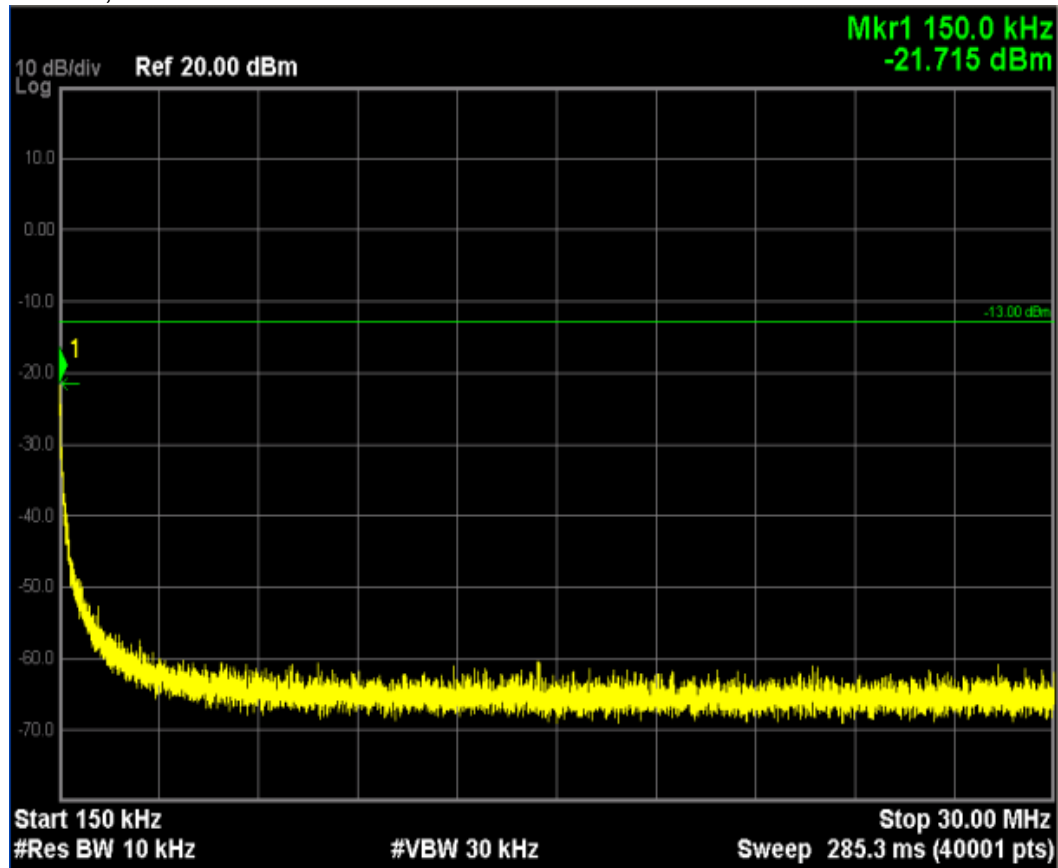

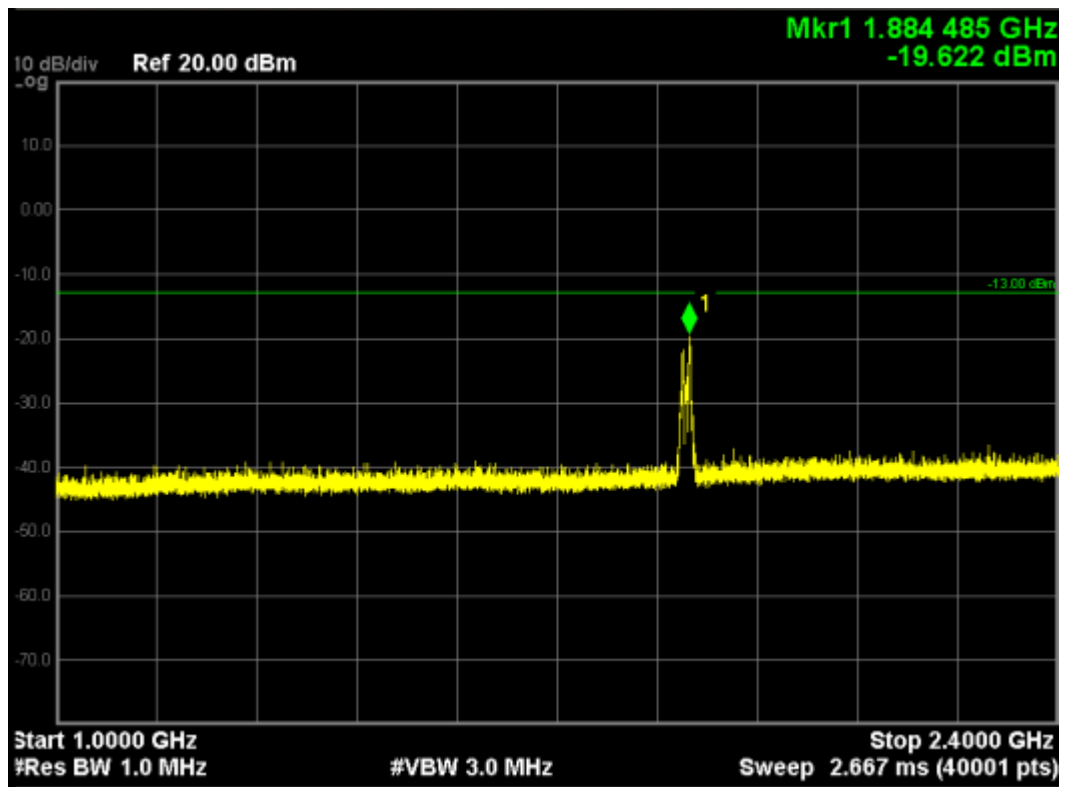
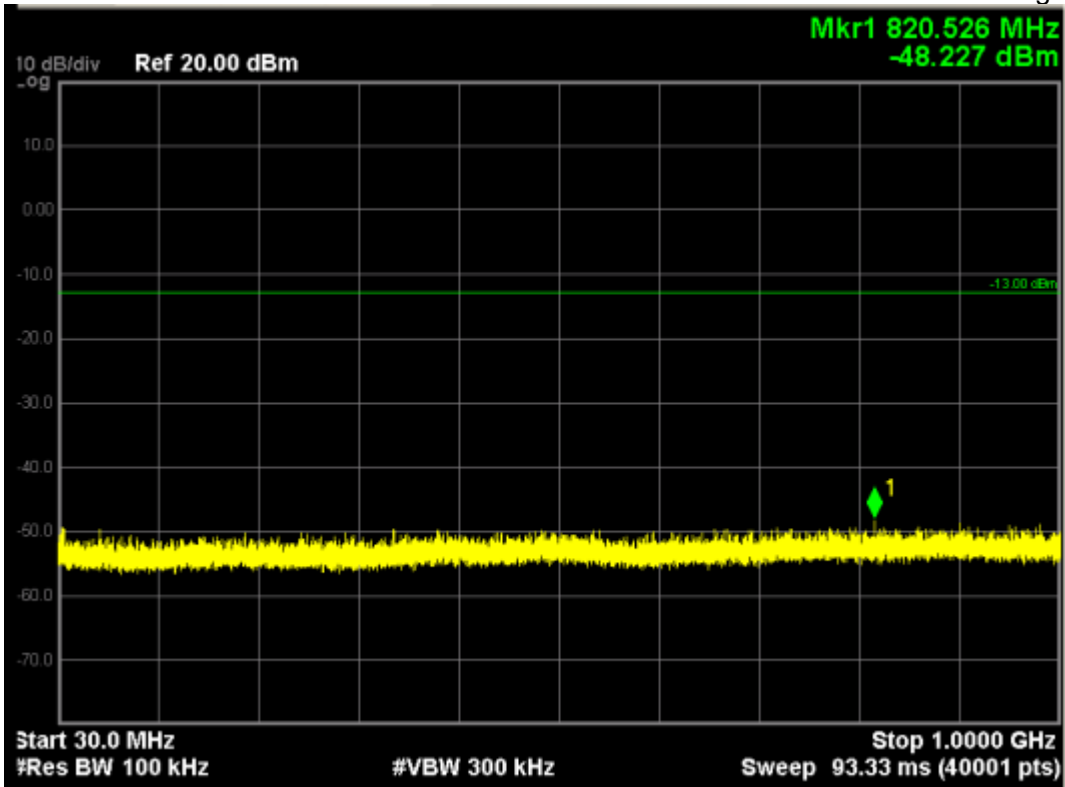

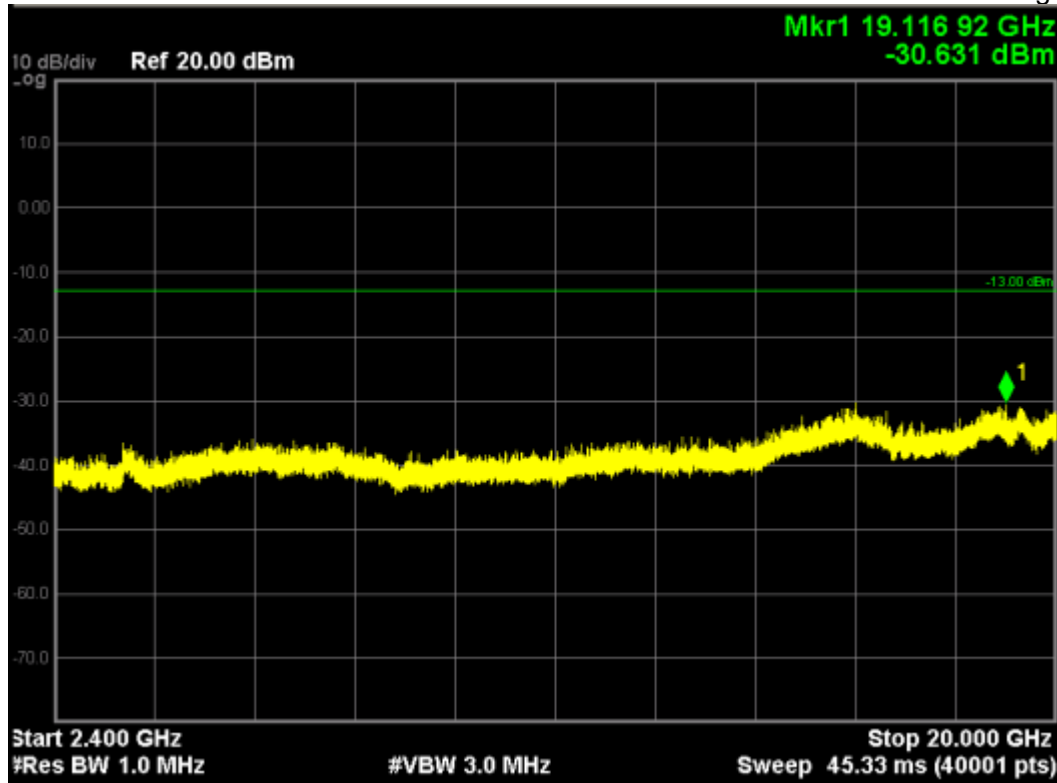

Radiated Spurious Measurement:

WCDMA Band V30MHz to 1GHz

Frequency (MHz)	Ant. Pol. (H/V)	SG Reading (dBm)	Cable Loss (dB)	Gain (dBd)	ERP (dBm)	Limit (dBm)	Margin (dB)
Middle Channel 4407 (836.40MHz)							
667.8	H	-51.67	2.97	-2.16	-56.80	-13.00	-43.80
667.8	V	-48.33	2.97	-2.16	-53.46	-13.00	-40.46

WCDMA Band VAbove 1GHz

Frequency (MHz)	Ant. Pol. (H/V)	SG Reading (dBm)	Cable Loss (dB)	Gain (dBd)	ERP (dBm)	Limit (dBm)	Margin (dB)
Middle Channel 4407 (836.40MHz)							
1672.8	H	-43.86	6.13	9.40	-40.59	-13.00	-27.59
1672.8	V	-45.69	6.13	9.40	-42.42	-13.00	-29.42
2509.2	H	-37.51	7.32	10.5	-34.33	-13.00	-21.33
2509.2	V	-35.29	7.32	10.5	-32.11	-13.00	-19.11
3345.6	H	-35.87	8.43	11.5	-32.80	-13.00	-19.80
3345.6	V	-32.69	8.43	11.5	-29.62	-13.00	-16.62

WCDMA Band II30MHz to 1GHz

Frequency (MHz)	Ant. Pol. (H/V)	SG Reading (dBm)	Cable Loss (dB)	Gain (dBd)	ERP (dBm)	Limit (dBm)	Margin (dB)
Middle Channel 1412 (1732.4MHz)							
667.8	H	-49.37	2.97	-2.16	-54.50	-13.00	-41.50
667.8	V	-45.62	2.97	-2.16	-50.75	-13.00	-37.75

WCDMA Band IIAbove 1GHz

Frequency (MHz)	Ant. Pol. (H/V)	SG Reading (dBm)	Cable Loss (dB)	Gain (dBd)	ERP (dBm)	Limit (dBm)	Margin (dB)
Middle Channel 1412 (1732.4MHz)							
1881.25	H	-28.78	6.19	8.25	-26.72	-13.00	-13.72
3761.25	H	-38.28	8.95	10.45	-36.78	-13.00	-23.78
1881.25	V	-26.11	6.19	8.25	-24.05	-13.00	-11.05
3761.25	V	-36.39	8.95	10.45	-34.89	-13.00	-21.89

7. Frequency Stability Under Temperature & Voltage Variations

7.1. Test Equipment

Instrument	Manufacturer	Model	Serial No.	Cali. Due Date
SpectrumAnalyzer	Agilent	N9038A	MY51210142	11/01/2017
RadioCommunicationTester	Agilent	E5515C	GB46581718	11/03/2017
DC Power Supply	Agilent	6612C	MY43002989	06/01/2017
Temperature Chamber	WEISS	DU/20/40	58226017340050	05/26/2017

The measure equipment had been calibrated once a year.

7.2. Test Setup

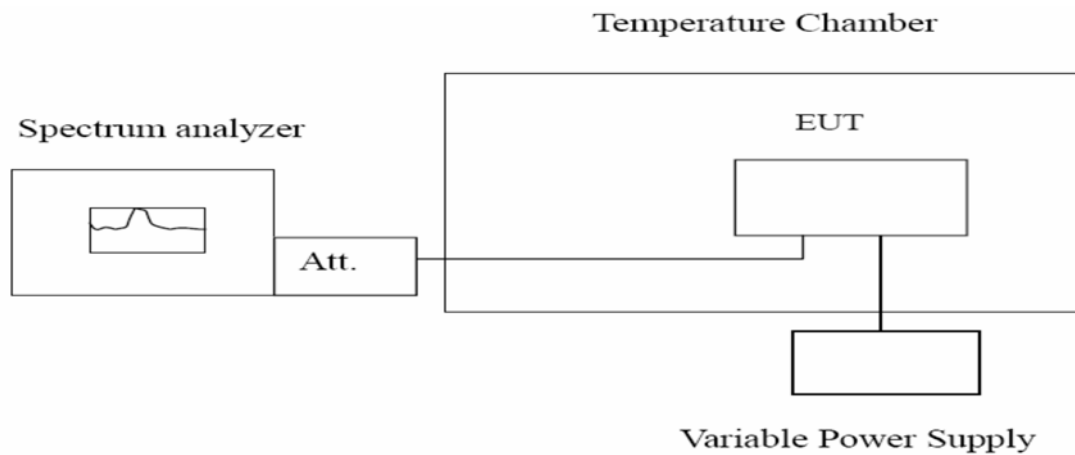

The frequency stability shall be sufficient to ensure that the fundamental emission stays within the authorized frequency block.

Limit	$< \pm 2.5$ ppm
-------	-----------------

7.4. Test Procedure

1.The testing follows FCC KDB 971168 v02v02 Section 9.0;

2.Frequency Stability Under Temperature Variations:

The equipment under test was connected to an external AC or DC power supply and input rated voltage. RF output was connected to a frequency counter or Agilent 8960. The EUT was placed inside the temperature chamber.

EUT 20°C operating frequency as reference frequency. Turn EUT off and set the chamber temperature to -30°C. After the temperature stabilized for approximately 30 minutes recorded the frequency. Repeat step measure with 10°C increased per stage until the highest temperature of +50°C reached.

3.Frequency Stability Under Voltage Variations:

Set chamber temperature to 20°C. Use a variable AC power supply / DC power source to power the EUT and set the voltage to rated voltage.

Reduce the input voltage to specify extreme voltage variation ($\pm 15\%$) and endpoint, record the maximum frequency change.

7.5. Uncertainty

The measurement uncertainty is defined as ± 10 Hz.

7.6. Test Result

WCDMA Band V:

Frequency Stability under Temperature

Temperature Interval (°C)	Test Frequency (MHz)	Deviation (Hz)	Limit(Hz)	Result
-30	836.40	-1.79	±2091	PASS
-20	836.40	6.80	±2091	
-10	836.40	-0.57	±2091	
0	836.40	1.32	±2091	
10	836.40	3.52	±2091	
20	836.40	-1.86	±2091	
30	836.40	-7.84	±2091	
40	836.40	2.34	±2091	
50	836.40	-18.57	±2091	

Frequency Stability under Voltage

DC Voltage (V)	Test Frequency (MHz)	Deviation (Hz)	Limit(Hz)	Result
3.0	836.40	-36.14	±2091	PASS
3.8	836.40	-37.83	±2091	
4.5	836.40	-36.87	±2091	

WCDMA BandII:

Frequency Stability under Temperature

Temperature Interval (°C)	Test Frequency (MHz)	Deviation (Hz)	Limit(Hz)	Result
-30	1880.00	17.68	±4700	PASS
-20	1880.00	19.32	±4700	
-10	1880.00	-15.32	±4700	
0	1880.00	-18.21	±4700	
10	1880.00	-15.36	±4700	
20	1880.00	-11.45	±4700	
30	1880.00	-15.64	±4700	
40	1880.00	14.22	±4700	
50	1880.00	21.32	±4700	

Frequency Stability under Voltage

DC Voltage (V)	Test Frequency (MHz)	Deviation (Hz)	Limit(Hz)	Result
3.64	1880.00	18.29	±4700	PASS
3.8	1880.00	-16.41	±4700	
4.2	1880.00	24.83	±4700	

Notes: the manufacture declared that the EUT could work between voltages 3.64V~4.2 V, and this EUT could normally work under the condition from -30°C to 70°C.

8.Attachment

PHOTOGRAPHS OF TEST SETUP

Please refer to the file named "RF Setup Photos".

PHOTOGRAPHS OF EUT

Please refer to the two files named "External Photos"..

----End of the report----