

User Manual

For Android Control Board

With

Wireless module

Product : Digital Transmission System

Model No : FBP205

1. Applicable Products

Model Description	Model
32 " Display	67401
43 " Display	67301
49 " Display	64909
55 " Display	64428

2. Feature

Feature	Implementation
Power Supply	5.0V±0.25V
Temperature range	Work temperature : -20°C ~ +70°C Storage temperature : -55°C ~ +125°C

3. Environmental Characteristics

(1) Temperature

Operating : 0°C ~ +40°C

Storage : -20°C ~ +70°C

(2) Humidity

Operating : 10% to 90% (non-condensing)

Storage : 5% to 95% (non-condensing)

(3) Altitude

Operating : 10,000 ft. (max)

Storage : 20,000 ft. (max)

4. Hardware Connection

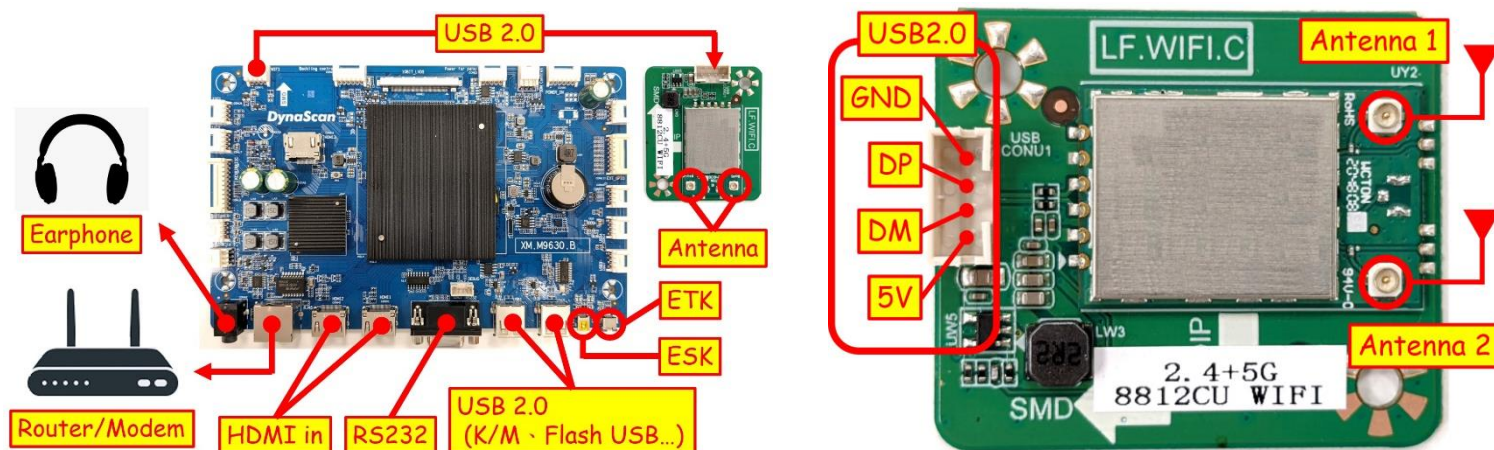

Connector		Description
USB2.0	5V	5V Supply Voltage
	DM	USB Data —
	DP	USB Data +
	GND	Ground
Antenna 1	Single-band 5G or dual-band antennas can be used, single-band 2.4G antennas cannot be used	
Antenna 2		

5. Module Specification

(1) General Description

This document is to specify the product requirements for 802.11a/b/g/n/ac USB Module. This Card is based on REALTEK RTL8812CU chipset .It is a complete dual-band(2.4GHz and 5GHz)WIFI 2×2 MIMO MAC/PHY/Radio System-on-a-Chip. This module provides a high level of integration with a dual-stream IEEE 802.11ac MAC/ base band/radio. The WLAN operation supports 20MHz,40MHz and 80MHz channels for data rates up to 866.7Mbps. It is also backward complied with IEEE 802.11a standard from 5.15~5.825GHz wideband and IEEE 802.11b/g standard from 2.4~2.5GHz. It can be used to provide up to 54Mbps for IEEE 802.11a and IEEE 802.11g, 11Mbps for IEEE 802.11b and 300Mbps for IEEE 802.11n.

(2) Features

- Compatible with IEEE 802.11a standard to provide wireless 54Mbps data rate.
- Compatible with IEEE 802.11b standard to provide wireless 11Mbps data rate.
- Compatible with IEEE 802.11g standard to provide wireless 54Mbps data rate.
- Compatible with IEEE 802.11n standard to provide wireless 300Mbps data rate.
- Compatible with IEEE 802.11ac standard to provide wireless 866.7Mbps data rate.
- Support 20MHz, 40MHz bandwidth in 2.4GHz band
- Operation at 2.4G ~ 5GHz and 5.15 ~ 5.825GHz frequency band to meet worldwide regulations
- Supports MU-MIMO.
- Support STBC, LDPC
- Supports IEEE 802.11i (WPA and WPA2), WAPI.
- Drivers support Windows, Linux, Android
- High speed USB 2.0 interface
- RoHS compliant

6. Application Diagrams

(1) Functional Block Diagram

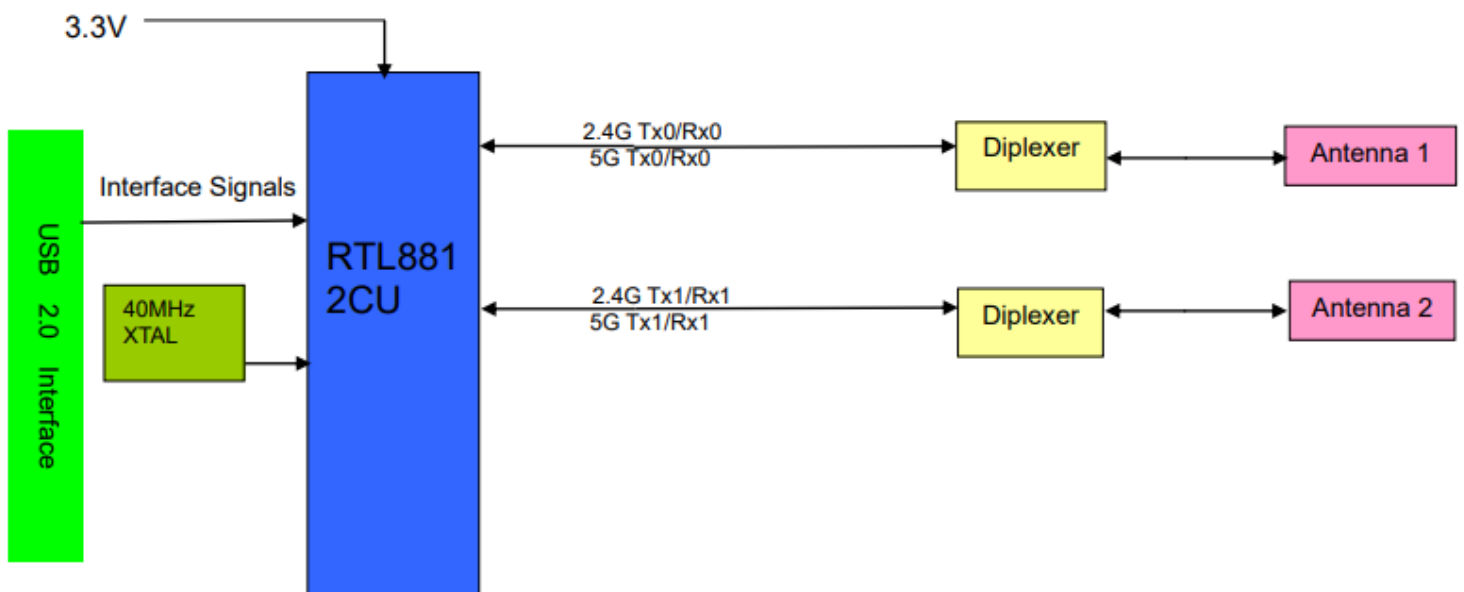

(2) General Requirements

➤ IEEE 802.11a Section

Feature	Detailed Description
Radio and Modulation Type	QPSK · BPSK · 16QAM · 64QAM with OFDM
Operating Frequency	5.15G ~ 5.25GHz
	5.725G ~ 5.825GHz
Data Rate	at most 54Mbps
Media Access Protocol	CSMA / CA with ACK
Transmitter Output Power at Antenna Connector	Typical RF Output Power (tolerance±2dB) at each RF chain, Data Rate and at room Temp. 25 degree C
	15±2 dBm at 54Mbps
Receiver Sensitivity at Antenna Connector	Typical Sensitivity at each RF chain. Frame (1000-byte PDUs) Error Rate < 10% at room Temp. 25 degree C
	-73 dBm at 54Mbps

➤ IEEE 802.11b Section

Feature	Detailed Description
Radio and Modulation Schemes	DQPSK · DBPSK · DSSS · CCK
Operating Frequency	2400M ~ 2483.5MHz, ISM band
Channel Numbers	13 channels for Worldwide
Data Rate	at most 11Mbps
Media Access Protocol	CSMA / CA with ACK
Transmitter Output Power at Antenna Connector	Typical RF Output Power (tolerance±2dB) at each RF chain, Data Rate and at room Temp. 25 degree C
	16±2 dBm at 11Mbps
Receiver Sensitivity at Antenna Connector	Typical Sensitivity at Which Frame (1000-byte PDUs) Error Rate = 8% at room Temp. 25 degree C
	-82 dBm at 11Mbps

► IEEE 802.11g Section

Feature	Detailed Description
Radio and Modulation Type	QPSK · BPSK · 16QAM · 64QAM with OFDM
Operating Frequency	2400M ~ 2483.5MHz, ISM band
Channel Numbers	13 channels for Worldwide
Data Rate	at most 54Mbps
Media Access Protocol	CSMA / CA with ACK
Transmitter Output Power at Antenna Connector	Typical RF Output Power (tolerance±2dB) at each RF chain, Data Rate and at room Temp. 25 degree C
	15±2 dBm at 54Mbps
Receiver Sensitivity at Antenna Connector	Typical Sensitivity at Which Frame (1000-byte PDUs) Error Rate < 10% at room Temp. 25 degree C
	-73 dBm at 54Mbps

► IEEE 802.11n Section

Feature	Detailed Description	
Radio and Modulation Type	QPSK · BPSK · 16QAM · 64QAM with OFDM	
Operating Frequency	2.4GHz	2400M ~ 2483.5MHz
	5GHz	5.15G ~ 5.25GHz
		5.725G ~ 5.825GHz
Data Rate	at most 300Mbps	
Media Access Protocol	CSMA / CA with ACK	
Transmitter Output Power at Antenna Connector	Typical RF Output Power (tolerance±2dB) at each RF chain, Data Rate and at room Temp. 25 degree C	
	2.4GHz Band / HT20 / HT40	15±2 dBm at MCS7
	5GHz Band / HT20 / HT40	
Receiver Sensitivity at Antenna Connector	Typical Sensitivity at each RF chain. Frame (1000-byte PDUs) Error Rate = 10% at room Temp. 25 degree C	

	2.4GHz Band / HT20	-70 dBm at MCS7
	2.4GHz Band / HT40	-66 dBm at MCS7
	5GHz Band / HT20	-71 dBm at MCS7
	5GHz Band / HT40	-67 dBm at MCS7

► IEEE 802.11ac Section

Feature	Detailed Description
Radio and Modulation Schemes	QPSK · BPSK · 16QAM · 64QAM · 256QAM · OFDM
Operating Frequency	5.15 ~ 5.25GHz ; 5.725 ~ 5.825GHz
Data Rate	at most 866.7Mbps
Media Access Protocol	CSMA / CA with ACK
Transmitter Output Power at Antenna Connector	Typical RF Output Power (tolerance \pm 2dB) at each RF chain, Data Rate and at room Temp. 25 degree C
	HT20 : 15 \pm 2 dBm at MCS8
	HT40 : 15 \pm 2 dBm at MCS9 HT80 : 13 \pm 2 dBm at MCS9
Receiver Sensitivity at Antenna Connector	Typical Sensitivity at each RF chain. Frame (1000-byte PDUs) Error Rate < 10% at room Temp. 25 degree C
	5GHz Band / HT20 : -64 dBm at MCS8
	5GHz Band / HT40 : -61 dBm at MCS9 5GHz Band / HT80 : -58 dBm at MCS9

FCC Statement :

FEDERAL COMMUNICATIONS COMMISSION INTERFERENCE STATEMENT

This equipment has been tested and found to comply with the limits for a Class A digital device, pursuant to part 15 of the FCC Rules. These limits are designed to provide reasonable protection against harmful interference when the equipment is operated in a commercial environment. This equipment generates, uses, and can radiate radio frequency energy and, if not installed and used in accordance with the instruction manual, may cause harmful interference to radio communications. Operation of this equipment in a residential area is likely to cause harmful interference in which case the user will be required to correct the interference at his own expense.

CAUTION :

Any changes or modifications not expressly approved by the grantee of this device could void the user's authority to operate the equipment.

This device complies with part 15 of the FCC Rules. Operation is subject to the following two conditions: (1) This device may not cause harmful interference, and (2) this device must accept any interference received, including interference that may cause undesired operation.

RF exposure warning :

This equipment must be installed and operated in accordance with provided instructions and the antenna(s) used for this transmitter must be installed to provide a separation distance of at least 20 cm from all persons and must not be co-located or operating in conjunction with any other antenna or transmitter. End-users and installers must be provide with antenna installation instructions and transmitter operating conditions for satisfying RF exposure compliance.

End Product Labeling :

The end product shall bear the following 15.19 statement: This device complies with part 15 of the FCC Rules. Operation is subject to the following two conditions: (1) This device may not cause harmful interference, and (2) this device must accept any interference received, including interference that may cause undesired operation.

This transmitter module is authorized only for use in device where the antenna may be installed such that 20cm may be maintained between the antenna and users. The final end product must be labeled in a visible area with the following:

" Contains FCC ID: 2AKWYFBP205 "

This module is intended under the following conditions :

1. This module is certified pursuant to Part 15 rules section (15.247).
2. This module is limited to host model number: 67301, 67401, 64909, 64428/ Brand: DynaScan
3. This module has been approved to operate with the antenna types listed below, with the maximum permissible gain indicated.

Frequency Band	Antenna Type	Gain(dBi)
2400-2500MHz	PIFA	-3.04
5150-5850MHz	PIFA	-2.31

Information on test modes and additional testing requirements :

This module is restricted to integration into hosts for indoor use only.

Be limited the operation channels in channel 1-11 for 2.4GHz band.

The separate approval is required for all other operating configurations, including portable configurations with respect to Part 2.1093 and different antenna configurations.

The information on how to configure test modes for host product evaluation for different operational conditions for a stand-alone modular transmitter in a host, versus with multiple, simultaneously transmitting modules or other transmitters in a host can be found at KDB Publication 996369 D04.

According to KDB 388624 requirements we will retain control over the final installation of the modular such that compliance of the end product is assured.

Clear and specific instructions describing the conditions, limitations and procedures for third parties to use and/or integrate the module into a host device (see Comprehensive integration instructions below). Resolve: Supply example as follows:

Installation Notes:

- (1) When connect module to the host device, the host device must be power off.
- (2) Make sure the module pins correctly installed.
- (3) Make sure that the module does not allow users to replace or demolition.
- (4) Host approval is limited in mobile condition.
- (5) Labeling are pre-checked by modular vendor before marking.
- (6) Output power, and spurious emission are checked as always prior to permission to sign before marking.

Additional testing, Part 15 Subpart B disclaimer :

Appropriate measurements (e.g. 15B compliance) and if applicable additional equipment authorizations (e.g. SDoC) of the host product to be addressed by the integrator/manufacture. This module is only FCC authorized for the specific rule part 15.247 listed on the grant, and the host product manufacturer is responsible for compliance to any other FCC rules that apply to the host product as being Part 15 Subpart B compliant.

The user manual of the end product should include :

This device complies with part 15 of the FCC Rules. Operation is subject to the following two conditions: (1) This device may not cause harmful interference, and (2) this device must accept any interference received, including interference that may cause undesired operation.

Any changes or modifications not expressly approved by the party responsible for compliance could void the user's authority to operate this equipment.

The antenna(s) used for this transmitter must be installed to provide a separation distance of at least 20 cm from all persons.

This device and its antenna(s) must not be co-located or operating in conjunction with any other antenna or transmitter.

For product available in the USA/Canada market, only channel 1~11 can be operated. Selection of other channels is not possible.

Name: DynaScan Technology, Inc.

Address: 7 Chrysler, Irvine, CA 92618, USA

Office: +1 949.421.0348

<https://www.dynascandisplay.com>