

Dynascan Technology Corp.

TEST REPORT

Model:
FBP205

REPORT NUMBER
220900340THC-001

ISSUE DATE
Oct. 28, 2022

PAGES
38

DOCUMENT CONTROL NUMBER
GFT-OP-10h (28-Nov-2018)
© 2020 Intertek



Radio Spectrum TEST REPORT

Applicant:	Dynascan Technology Corp. 6F., No. 88, Wenmao Rd., Guishan Dist., Taoyuan City 333001, Taiwan
Product:	Digital Transmission Systems
Model No.:	FBP205
FCC ID:	2AKWYFBP205
Test Method/ Standard:	47 CFR FCC Part 15.407 KDB 789033 D02 v02r01 ANSI C63.10 2013 KDB 662911 D01 v02r01
Test By:	Intertek Testing Services Taiwan Ltd., Hsinchu Laboratory No. 11, Lane 275, Ko-Nan 1 Street, Chia-Tung Li, Shiang-Shan District, Hsinchu City, Taiwan



Rich Nien

Rich Nien
Engineer

Zero chen

Zero Chen
Reviewer

This report is for the exclusive use of Intertek's Client and is provided pursuant to the agreement between Intertek and its Client. Intertek's responsibility and liability are limited to the terms and conditions of the agreement. Intertek assumes no liability to any party, other than to the Client in accordance with the agreement, for any loss, expense or damage occasioned by the use of this report. Only the Client is authorized to permit copying or distribution of this report and then only in its entirety. Any use of the Intertek name or one of its marks for the sale or advertisement of the tested material, product or service must first be approved in writing by Intertek. The observations and test results in this report are relevant only to the sample tested. This report by itself does not imply that the material, product, or service is or has ever been under an Intertek certification program.

TEST REPORT**Revision History**

Report No.	Issue Date	Revision Summary
220900340THC-001	Oct. 28, 2022	<ol style="list-style-type: none">1. This case is to add different Host(Product Name: 55" Display, Model No.: 64428), so the FCC C2PC (Conducted Output Power, Spurious Emission, Band Edge, and AC Conducted Emissions) is exeuted.2. FCC Original Grant Date: 07/01/2022, FCC ID: 2AKWYFBP205

Table of Contents

Summary of Test Data	4
1. General Information	5
1.1 Identification of the EUT	5
1.2 Description of the EUT	5
1.3 Antenna description	6
1.4 Operation mode	6
2. Maximum Conducted Output Power	7
2.1 Limit for maximum output power	7
2.2 Measuring instrument setting.....	7
2.3 Test procedure.....	7
2.4 Test diagram	7
2.5 Test results.....	8
3. Emissions in Restricted Frequency Bands (Radiated emission measurements)	9
3.1 Limit for emission in restricted frequency bands (Radiated emission measurement)	9
3.2 Measuring instrument setting.....	10
3.3 Test procedure.....	11
3.4 Test configuration.....	12
3.4.1 Radiated emission from 9 kHz to 30MHz using Loop Antenna	12
3.5 Test results.....	14
3.5.1 Measurement results: frequencies from 9 kHz to 30MHz	14
3.5.2 Measurement results from 30 MHz to 1GHz	16
3.5.3 Measurement results from 1 GHz to 40 GHz	17
4. Emission on The Band Edge.....	18
4.1 Measuring instrument setting.....	18
4.2 Test procedure.....	18
4.3 Limit for Band Edge (Radiated emission measurement).....	18
4.4 Test Result.....	19
5. AC Power Line Conducted Emission	32
5.1 Measuring instrument setting.....	32
5.2 Test Procedure.....	32
5.3 Test Diagram	33
5.4 Limit.....	33
7.5 Test Results.....	34
Appendix A: Test equipment list.....	36
Appendix B: Measurement Uncertainty.....	38

Summary of Test Data

Test Requirement	Applicable Rule (Section 15.407)	Result
Maximum Conducted Output Power	15.407 (a)(1)/(2)/(3) KDB 789033 D02 v01r02	Pass
Emissions In Restricted Frequency Bands (Radiated emission measurements)	15.407(b), 15.209	Pass
Emission on The Band Edge	15.407(b), 15.209	Pass
AC Line Conducted Emission	15.407(b)(6) 15.207	Pass
Antenna requirement	15.203	Pass

Note: Please note that the test results with statement of conformity, the decision rules which are based on: Safety Testing: the specification, standard or IEC Guide 115.

Other Testing: the specification, standard and not taking into account the measurement uncertainty.

1. General Information

1.1 Identification of the EUT

Product:	Digital Transmission System
Model No.:	FBP205
Operating Frequency:	1. 5180MHz~5240MHz 2. 5745MHz~5825MHz
Channel Number:	1. 7 channels for 5180MHz ~ 5240MHz 2. 8 channels for 5745MHz ~ 5825MHz
Access scheme:	OFDM
Rated Power:	DC 3.3V
Power Cord:	N/A
Sample receiving date:	2022/09/19
Sample condition:	Workable
Test Date(s):	2022/10/05 ~ 2022/10/11

1.2 Description of the EUT

Modulation mode	Transmit path	
	Chain 0	Chain 1
802.11 a	V	V
802.11 ac (VHT20)	V	V
802.11 ac (VHT40)	V	V
802.11 ac (VHT80)	V	V

Item	Product name	Model No.	Rated Power
Host	55" Display	64428	100-240V~ 50/60Hz 3A

1.3 Antenna description

For antenna 0 (Chain 0)

Antenna Gain : -2.31 dBi
Antenna Type : PIFA antenna
Connector Type : I-pex

For antenna 1 (Chain 1)

Antenna Gain : -2.31 dBi
Antenna Type : PIFA antenna
Connector Type : I-pex

1.4 Operation mode

Power on, executing "WLAN Test Tool V2.3.0" to select different frequency and modulation.

With individual verifying, the maximum output power were found out 6 Mbps data rate for 802.11a mode, 6.5 Mbps data rate for 802.11ac(VHT20) mode, 13.5 Mbps data rate for 802.11ac(VHT40) mode , 29.3 Mbps data rate for 802.11ac(VHT80) mode, the final tests were executed under these conditions recorded in this report individually.

2. Maximum Conducted Output Power

2.1 Limit for maximum output power

Operating Frequency (MHz)	Conducted output power limit
5150~5725	< 0.25 W (24 dBm)
5725~5850	< 1 W (30 dBm)

Operating Frequency (MHz)	Maximum E.I.R.P. limit
5150~5725	< 1 W (30 dBm)
5725~5850	< 4 W (36 dBm)

2.2 Measuring instrument setting

Spectrum Analyzer function	Setting
RBW	=1 MHz
VBW	≥ 3 MHz
Sweep time	Auto couple
Detector	RMS
Trace	Average
Span	Encompass the EBW
Attenuation	Auto
Sweep point	≥ 2 Span / RBW

2.3 Test procedure

Test procedures refer to clause E) 2) d) Method SA-2 of KDB 789033 D02 v01r02

2.4 Test diagram

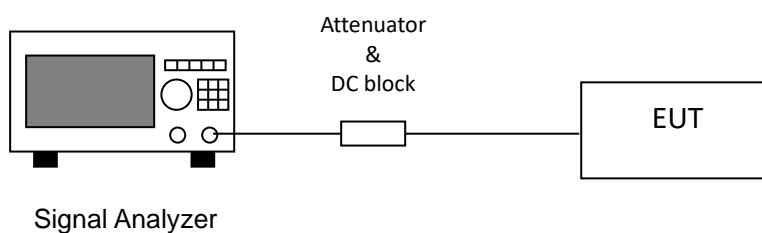

TEST REPORT

2.5 Test results

Temperature (°C) :	26
Relative Humidity (%) :	55
Test date :	2022/10/05
Host :	64428

Mode	Ch	Freq (MHz)	Output Power (AV)		Total Power (AV)		Duty Factor	Result dBm	Ant 0 Gain (dBi)	Ant 1 Gain (dBi)	E.I.R.P. (dBm)	Limit of Conducted Power (dBm)	Margin (dB)	Limit of E.I.R.P. (dBm)	Margin (dB)
			Chain 0	Chain 1	mW	dBm									
			dBm	dBm											
802.11a Chain0+1	36	5180	11.90	12.34	32.63	15.14	1.76	16.90	-2.31	-2.31	14.59	24	-7.10	30	-15.41
	44	5220	13.90	12.12	40.84	16.11	1.76	17.87	-2.31	-2.31	15.56	24	-6.13	30	-14.44
	48	5240	17.26	15.21	86.40	19.37	1.76	21.13	-2.31	-2.31	18.82	24	-2.87	30	-11.18
	149	5745	21.19	20.66	247.94	23.94	1.76	25.70	-2.31	-2.31	23.39	30	-4.30	36	-12.61
	157	5785	21.31	20.40	244.86	23.89	1.76	25.65	-2.31	-2.31	23.34	30	-4.35	36	-12.66
	165	5825	20.82	21.15	251.10	24.00	1.76	25.76	-2.31	-2.31	23.45	30	-4.24	36	-12.55
802.11ac (VHT20) Chain0+1	36	5180	9.78	8.68	16.89	12.28	0.97	13.24	-2.31	-2.31	10.93	24	-10.76	30	-19.07
	44	5220	11.13	11.18	26.09	14.17	0.97	15.13	-2.31	-2.31	12.82	24	-8.87	30	-17.18
	48	5240	16.74	15.81	85.31	19.31	0.97	20.28	-2.31	-2.31	17.97	24	-3.72	30	-12.03
	149	5745	21.26	20.58	247.95	23.94	0.97	24.91	-2.31	-2.31	22.60	30	-5.09	36	-13.40
	157	5785	21.21	20.78	251.80	24.01	0.97	24.98	-2.31	-2.31	22.67	30	-5.02	36	-13.33
	165	5825	20.65	20.80	236.37	23.74	0.97	24.71	-2.31	-2.31	22.40	30	-5.29	36	-13.60
802.11ac (VHT40) Chain0+1	38	5190	3.52	2.82	4.16	6.19	0.67	6.86	-2.31	-2.31	4.55	24	-17.14	30	-25.45
	46	5230	15.60	15.16	69.12	18.40	0.67	19.07	-2.31	-2.31	16.76	24	-4.93	30	-13.24
	151	5755	20.39	19.65	201.65	23.05	0.67	23.72	-2.31	-2.31	21.41	30	-6.28	36	-14.59
	159	5795	20.39	19.92	207.57	23.17	0.67	23.84	-2.31	-2.31	21.53	30	-6.16	36	-14.47
802.11ac (VHT80) Chain0+1	42	5210	5.14	3.95	5.75	7.60	0.51	8.11	-2.31	-2.31	5.80	24	-15.89	30	-24.20
	155	5775	18.42	18.08	133.77	21.26	0.51	21.78	-2.31	-2.31	19.47	30	-8.22	36	-16.53

Note: Result=Total Power+Duty Factor

TEST REPORT

3. Emissions in Restricted Frequency Bands (Radiated emission measurements)

3.1 Limit for emission in restricted frequency bands (Radiated emission measurement)

Frequency (MHz)	Field Strength (microvolts/meter)	Measurement distance (meters)
0.009~0.490	2400/F(kHz)	300
0.490~1.705	2400/F(kHz)	30
1.705~30	30	30
30-88	100	3
88-216	150	3
216-960	200	3
Above 960	500	3

Remark:

1. In the above table, the tighter limit applies at the band edges.
2. Distance refers to the distance in meters between the measuring instrument antenna and the closed point of any part of the device or system

As specified in 15.407(b), For transmitters operating in the 5.15-5.25 GHz band: All emissions outside of the 5.15-5.35 GHz band shall not exceed an e.i.r.p. of -27 dBm/MHz.

(2) For transmitters operating in the 5.25-5.35 GHz band: All emissions outside of the 5.15-5.35 GHz band shall not exceed an e.i.r.p. of -27 dBm/MHz.

(3) For transmitters operating in the 5.47-5.725 GHz band: All emissions outside of the 5.47-5.725 GHz band shall not exceed an e.i.r.p. of -27 dBm/MHz.

(4) For transmitters operating in the 5.725-5.85 GHz band:
 All emissions shall be limited to a level of -27 dBm/MHz at 75 MHz or more above or below the band edge increasing linearly to 10 dBm/MHz at 25 MHz above or below the band edge, and from 25 MHz above or below the band edge increasing linearly to a level of 15.6 dBm/MHz at 5 MHz above or below the band edge, and from 5 MHz above or below the band edge increasing linearly to a level of 27 dBm/MHz at the band edge.

However, an out-of-band emission that complies with both the average and peak limits of 15.209 is not required to satisfy the -27 dBm/MHz or -17 dBm/MHz peak emission limit.

3.2 Measuring instrument setting

Below 1GHz measurement

Receiver settings	
Receiver function	Setting
Detector	QP
RBW	9-150 kHz ; 200-300 Hz 0.15-30 MHz; 9-10 kHz 30-1000 MHz; 100-120 kHz
VBW	$\geq 3 \times$ RBW
Sweep	Auto couple
Attenuation	Auto

Above 1GHz measurement

Spectrum analyzer settings	
Spectrum Analyzer function	Setting
Detector	Peak ; Average
RBW	1MHz
VBW	3MHz for Peak; 1/T Minimum kHz for Average
Sweep	Auto couple
Start Frequency	1GHz
Stop Frequency	Tenth harmonic
Attenuation	Auto

3.3 Test procedure

1. Configure the EUT according to ANSI C63.10: 2013 The EUT was placed on the top of the turntable 1.5 meter above ground for above 1GHz and placed on the top of the turntable 0.8 meter above ground for below 1GHz. The center of the receiving antenna mounted on the top of a height-variable antenna tower was placed 3 meters far away from the turntable.
2. Power on the EUT and all the companion devices. The turntable was rotated by 360 degree to find the position of the maximum emission level.
3. The height of the receiving antenna was varied between one meter and four meters above ground to find the maximum emission field strength of the both horizontal and vertical polarization
4. If find the frequencies above the limit or below within 3dB, the antenna tower was scan (from 1m to 4m) and then the turntable was rotated to find the maximum reading.
5. Set the test-receiver system to peak or CISPR quasi-peak detector with specified bandwidth under maximum hold mode.
6. For emissions above 1GHz, use 1MHz VBW and 3MHz RBW for peak reading. Then 1MHz RBW and 10Hz VBW for average reading in spectrum analyzer.
Place the measurement antenna away from each area of the EUT determined to be a source of emissions at the specified measurement distance, while keeping the measurement antenna aimed at the source of emissions at each frequency of significant emissions, with polarization oriented for maximum response.
7. If the emissions level of the EUT in peak mode was 3dB lower than the average limit specified then testing will be stopped and peak values of the EUT will be reported. Otherwise, the emissions which do not have 3dB margin will be measured using the quasi-peak method for below 1GHz.
8. For testing above 1GHz, The emissions level of the EUT in peak mode was lower than average limit, then testing will be stopped and peak values of the EUT will be reported, otherwise, the emission will be measured in average mode again and reported.
9. In case the emission is lower than 30MHz, loop antenna has to be used for measurement and the recorded data should be quasi-peak measured by receiver.

3.4 Test configuration

3.4.1 Radiated emission from 9 kHz to 30MHz using Loop Antenna

Radiated emission from 9kHz to 30MHz uses Loop Antenna:

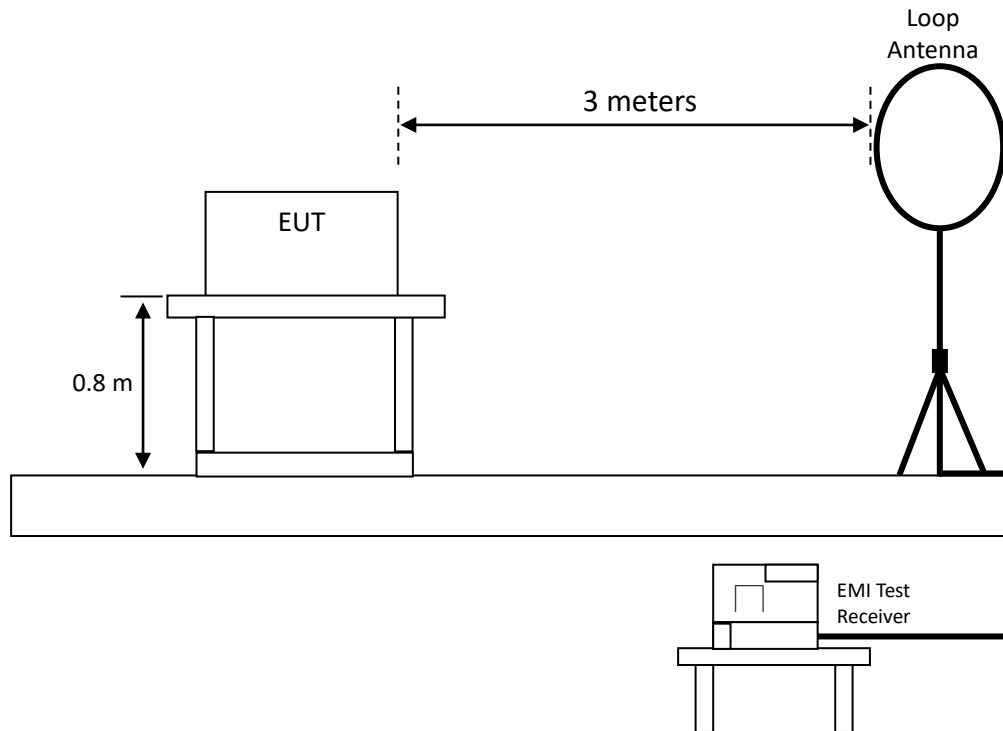

Radiated emission below 1GHz using Bilog Antenna

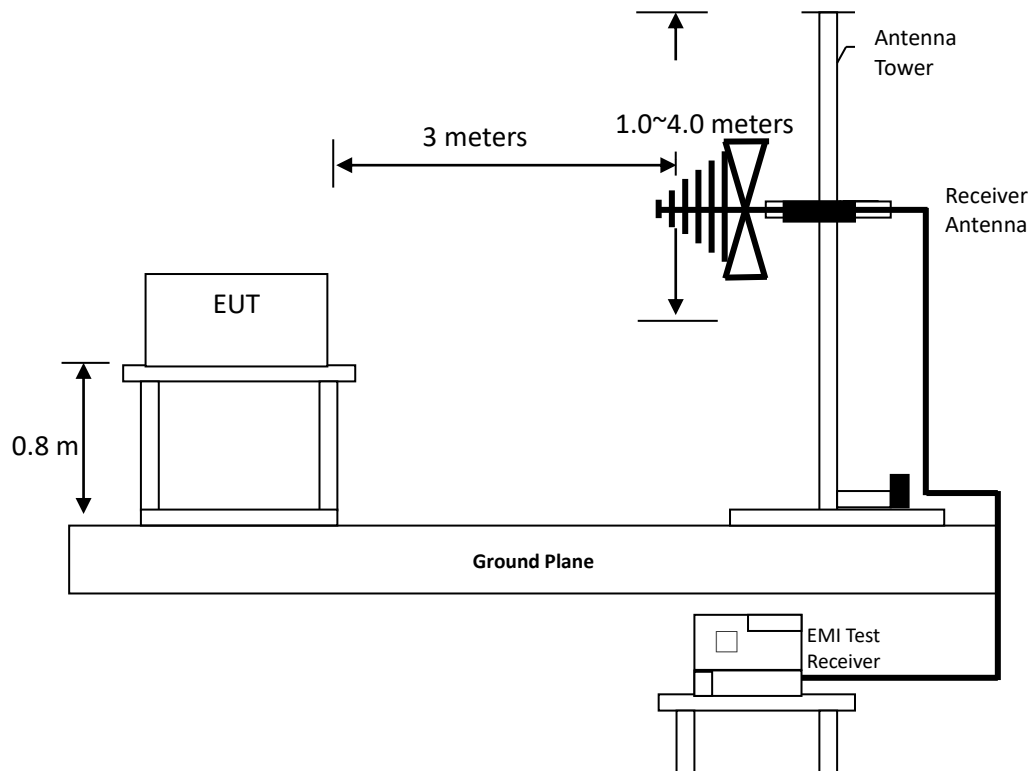

Radiated emission above 1GHz using Horn Antenna

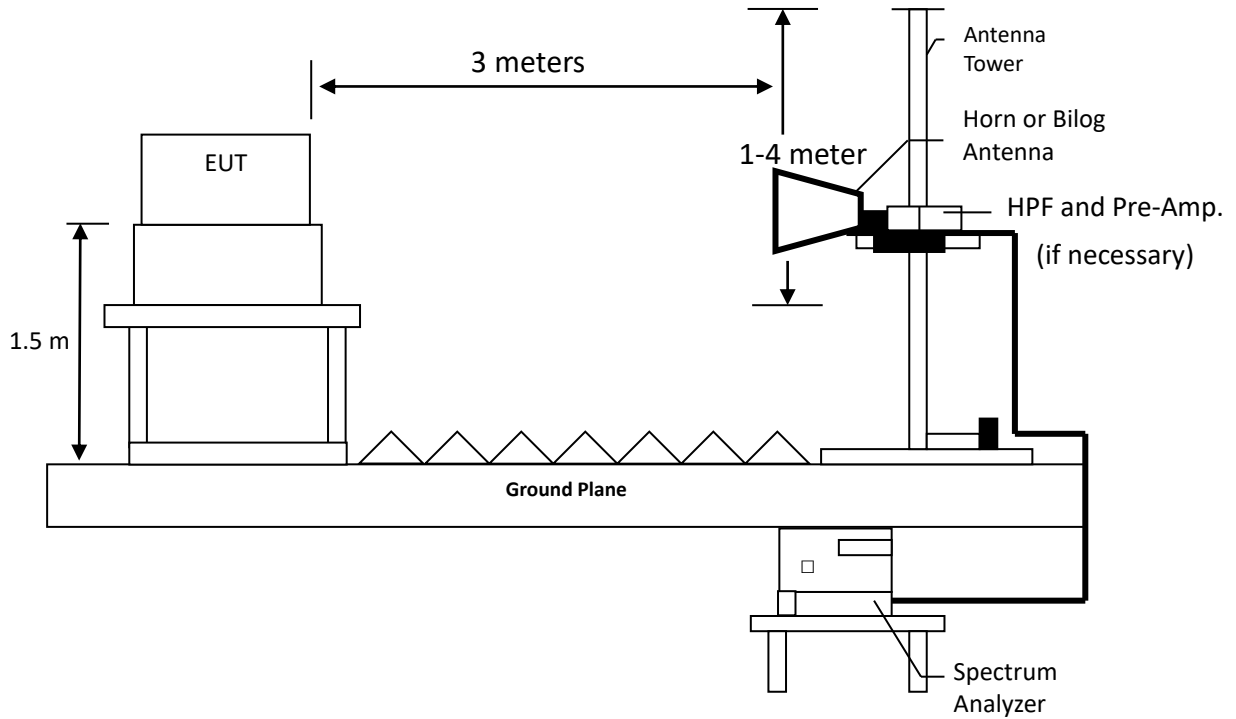

TEST REPORT

3.5 Test results

3.5.1 Measurement results: frequencies from 9 kHz to 30MHz

Temperature (°C) :	27
Relative Humidity (%) :	56
Test date :	2022/10/05
Host :	64428

The test was performed on EUT under 802.11a/an continuously transmitting mode. The worst case occurred at 802.11ac(VHT20) Chain0+1 Channel 157.

Antenna Polarity	Frequency (MHz)	Spectrum Analyzer Detector	Correction Factor (dB/m)	Reading (dBμV)	Corrected Reading (dBμV/m)	Limit @ 3 m (dBμV/m)	Margin (dB)
Perpendicular	0.009	AV	18.11	52.91	71.02	128.52	-57.50
Perpendicular	0.069	AV	18.76	42.93	61.69	114.73	-53.04
Perpendicular	0.129	AV	18.04	33.87	51.91	105.56	-53.65
Perpendicular	0.339	AV	18.66	28.07	46.73	97.02	-50.29
Perpendicular	0.519	QP	18.81	25.71	44.52	73.34	-28.82
Perpendicular	0.729	QP	18.94	23.61	42.55	70.43	-27.88

Remark: Corr. Factor = Antenna Factor + Cable Loss

Antenna Polarity	Frequency (MHz)	Spectrum Analyzer Detector	Correction Factor (dB/m)	Reading (dBμV)	Corrected Reading (dBμV/m)	Limit @ 3 m (dBμV/m)	Margin (dB)
Parallel	0.009	AV	18.11	53.48	71.59	128.52	-56.93
Parallel	0.129	AV	18.04	32.77	50.81	105.56	-54.75
Parallel	0.339	AV	18.66	26.71	45.37	97.02	-51.65
Parallel	0.519	QP	18.81	24.39	43.20	73.34	-30.14
Parallel	0.729	QP	18.94	22.66	41.60	70.43	-28.83
Parallel	0.999	QP	19.10	20.74	39.84	67.61	-27.77

Remark: Corr. Factor = Antenna Factor + Cable Loss

TEST REPORT

Antenna Polarity	Frequency (MHz)	Spectrum Analyzer Detector	Correction Factor (dB/m)	Reading (dBμV)	Corrected Reading (dBμV/m)	Limit @ 3 m (dBμV/m)	Margin (dB)
Ground-parallel	0.009	AV	18.11	55.23	73.34	128.52	-55.18
Ground-parallel	0.069	AV	18.76	37.14	55.90	114.73	-58.83
Ground-parallel	0.339	AV	18.66	22.04	40.70	97.02	-56.32
Ground-parallel	0.549	QP	18.83	19.32	38.15	72.86	-34.71
Ground-parallel	0.729	QP	18.94	18.99	37.93	70.43	-32.50
Ground-parallel	1.209	QP	19.10	17.63	36.73	65.96	-29.23

Remark: Corr. Factor = Antenna Factor + Cable Loss

TEST REPORT

3.5.2 Measurement results from 30 MHz to 1GHz

Temperature (°C) :	27
Relative Humidity (%) :	56
Test date :	2022/10/05
Host :	64428

The test was performed on EUT under 802.11a/an continuously transmitting mode. The worst case occurred at 802.11ac(VHT20) Chain0+1 Channel 157.

Antenna Polarity	Frequency (MHz)	Spectrum Analyzer Detector	Correction Factor (dB/m)	Reading (dBμV)	Corrected Reading (dBμV/m)	Limit @ 3 m (dBμV/m)	Margin (dB)
Vertical	42.61	QP	20.25	12.87	33.12	40.00	-6.88
Vertical	368.53	QP	23.44	19.38	42.82	46.00	-3.18
Vertical	602.30	QP	28.96	13.17	42.13	46.00	-3.87
Vertical	752.65	QP	31.56	13.64	45.20	46.00	-0.80
Vertical	828.31	QP	32.56	12.15	44.71	46.00	-1.29
Vertical	903.00	QP	33.20	8.77	41.97	46.00	-4.03

Antenna Polarity	Frequency (MHz)	Spectrum Analyzer Detector	Correction Factor (dB/m)	Reading (dBμV)	Corrected Reading (dBμV/m)	Limit @ 3 m (dBμV/m)	Margin (dB)
Horizontal	74.62	QP	17.42	21.23	38.65	40.00	-1.35
Horizontal	368.53	QP	23.44	16.42	39.86	46.00	-6.14
Horizontal	526.64	QP	27.07	14.20	41.27	46.00	-4.73
Horizontal	752.65	QP	31.56	11.10	42.66	46.00	-3.34
Horizontal	828.31	QP	32.56	9.35	41.91	46.00	-4.09
Horizontal	903.00	QP	33.20	8.11	41.31	46.00	-4.69

Remark: Corr. Factor = Antenna Factor + Cable Loss

TEST REPORT

3.5.3 Measurement results from 1 GHz to 40 GHz

Temperature (°C) :	27
Relative Humidity (%) :	56
Test date :	2022/10/05
Host :	64428

Mode	Frequency (MHz)	Spectrum Analyzer Detector	Ant. Pol. (H/V)	Correction Factor (dB/m)	Reading (dBµV)	Corrected Reading (dBµV/m)	Limit @ 3 m (dBµV/m)	Margin (dB)
802.11a_Ch48	10480	PK	H	9.17	37.99	47.16	74	-26.84
	10480	PK	V	9.17	39.07	48.24	74	-25.76
802.11a_Ch165	11650	PK	H	11.10	38.82	49.92	74	-24.08
	11650	PK	V	11.10	38.73	49.83	74	-24.17

Remark: Correction Factor = Antenna Factor + Cable Loss + High Pass Filter Loss - Pre_Amplifier Gain

4. Emission on The Band Edge

4.1 Measuring instrument setting

For 5.15 GHz -5.25 GHz

Spectrum analyzer settings	
Spectrum Analyzer function	Setting
Detector	Peak ; Average
RBW	1MHz
VBW	3MHz for Peak; 1/T Minimum kHz for Average
Sweep	Auto couple
Restrict bands	4500~5150MHz
	5350 ~5460MHz
Attenuation	Auto

For 5.725 GHz -5.850 GHz

Spectrum analyzer settings	
Spectrum Analyzer function	Setting
Detector	Peak
RBW	1MHz
VBW	3MHz
Sweep	Auto couple
Attenuation	Auto

4.2 Test procedure

The test procedure is the same as clause 3.3

4.3 Limit for Band Edge (Radiated emission measurement)

Refer to clause 3.1

TEST REPORT

4.4 Test Result

Temperature (°C) :	27
Relative Humidity (%) :	56
Test date :	2022/10/05
Host :	64428

Mode	Frequency (MHz)	Spectrum Analyzer Detector	Ant. Pol. (H/V)	Correction Factor (dB/m)	Reading (dBμV)	Corrected Reading (dBμV/m)	Limit @ 3 m (dBμV/m)	Margin (dB)	Restricted band (MHz)
802.11a Chain0	5122.08	PK	H	-5.74	60.69	54.95	74	-19.05	4500~5150
	5150.00	AV	H	-5.75	49.99	44.24	54	-9.76	
	5442.72	PK	H	-5.05	60.22	55.17	74	-18.83	5350~5460
	5452.32	AV	H	-4.98	49.08	44.10	54	-9.90	
802.11ac (VHT20) Chain0+1	5065.44	PK	H	-5.97	61.01	55.04	74	-18.96	4500~5150
	5150.00	AV	H	-5.75	49.58	43.83	54	-10.17	
	5440.80	PK	H	-5.07	61.25	56.18	74	-17.82	5350~5460
	5452.32	AV	H	-4.98	48.96	43.98	54	-10.02	
802.11ac (VHT40) Chain0+1	5150.00	PK	H	-5.75	58.42	52.67	74	-21.33	4500~5150
	5135.52	AV	H	-5.75	49.30	43.55	54	-10.45	
	5371.68	PK	H	-5.51	60.65	55.14	74	-18.86	5350~5460
	5450.40	AV	H	-4.99	49.30	44.31	54	-9.69	
802.11ac (VHT80) Chain0+1	5117.28	PK	H	-5.73	60.77	55.04	74	-18.96	4500~5150
	5111.52	AV	H	-5.74	49.99	44.25	54	-9.75	
	5452.32	PK	H	-4.98	60.86	55.88	74	-18.12	5350~5460
	5434.08	AV	H	-5.11	49.23	44.12	54	-9.88	

Remark: Correction Factor = Antenna Factor + Cable Loss - Pre_Amplifier Gain

Chain0+1 : Restricted Band Bandedge @ 802.11a Mode Ch36 PK

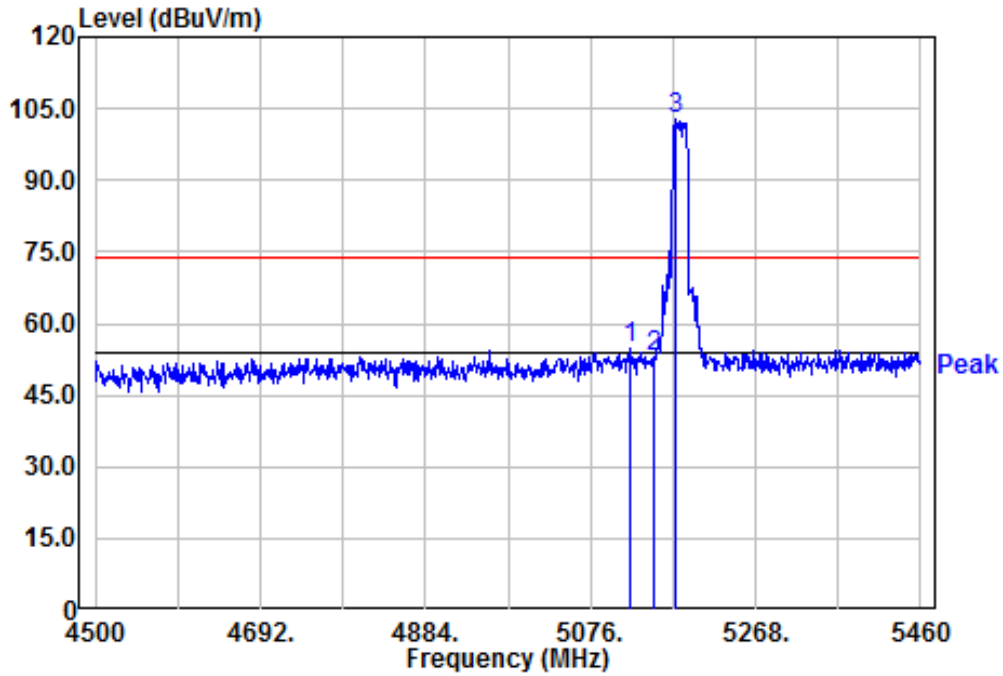

Chain0+1 : Restricted Band Bandedge @ 802.11a Mode Ch36 AV

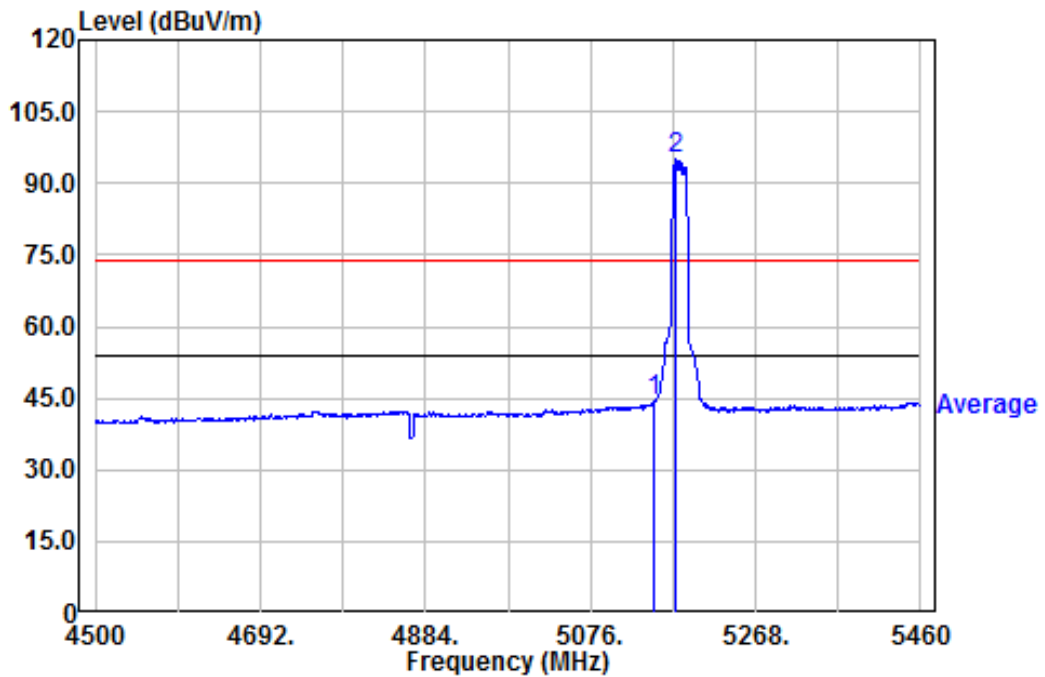

Chain0+1 : Restricted Band Bandedge @ 802.11a Mode Ch48 PK

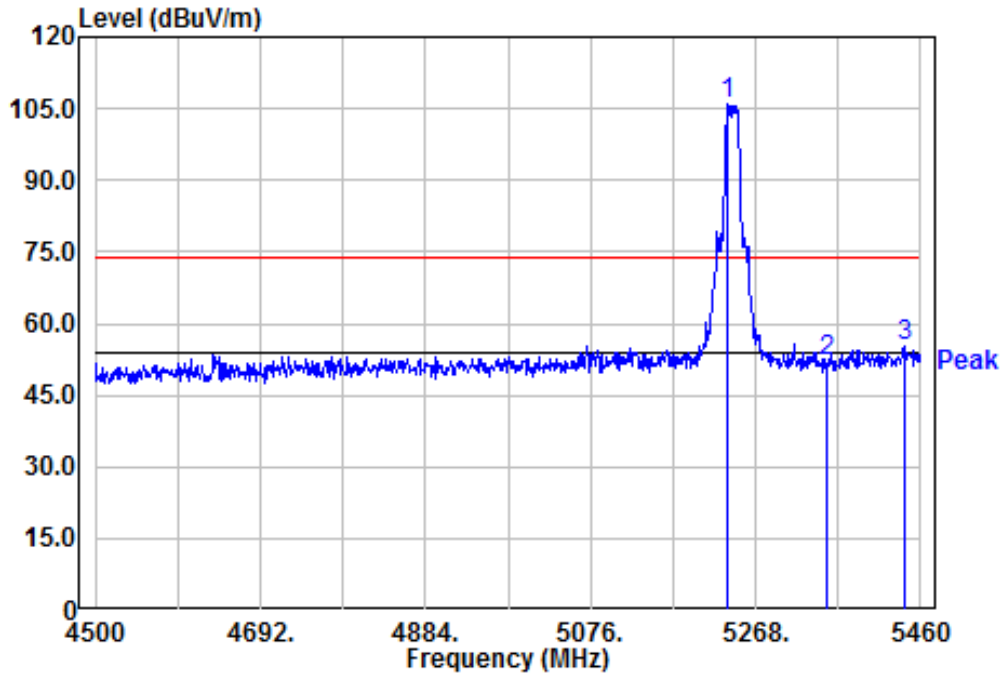

Chain0+1 : Restricted Band Bandedge @ 802.11a Mode Ch48 AV

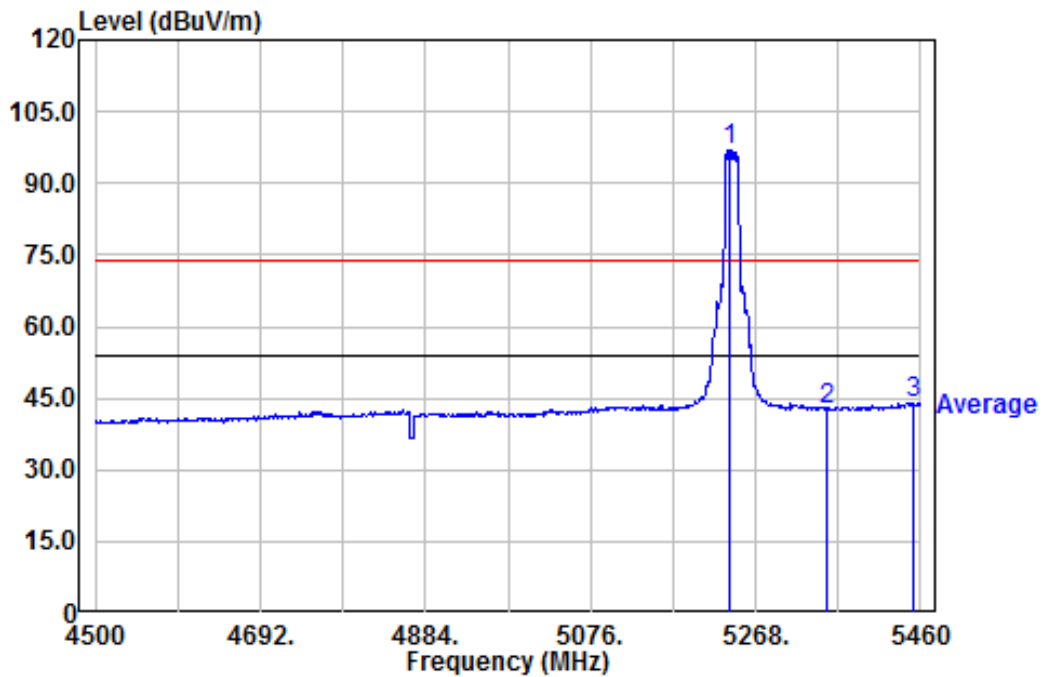

Chain0+1 : Restricted Band Bandedge @ 802.11ac(VHT20) Mode Ch36 PK

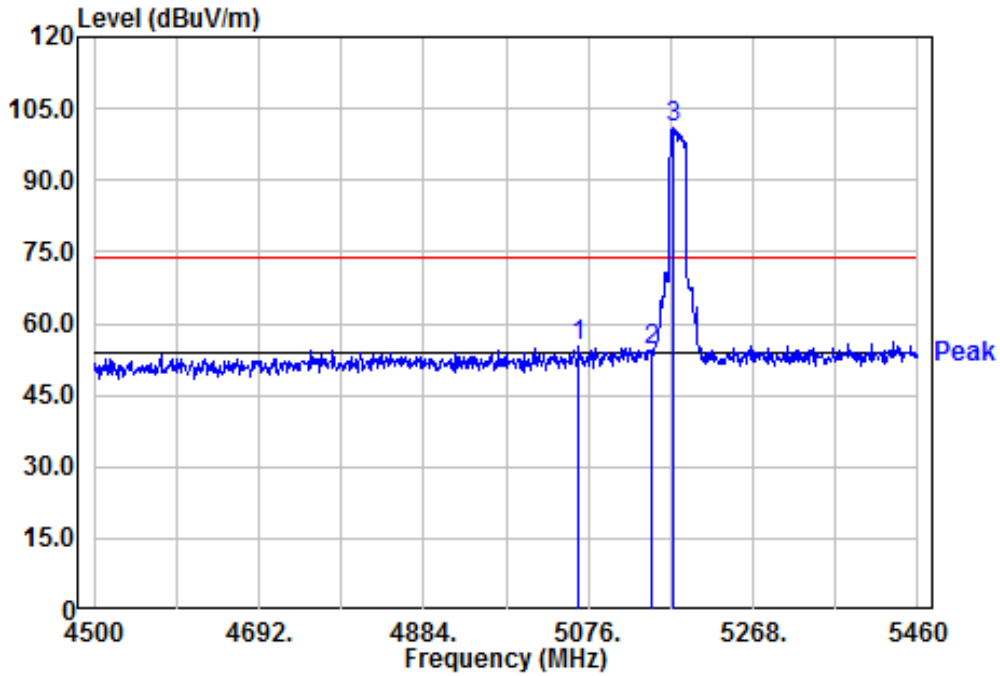

Chain0+1 : Restricted Band Bandedge @ 802.11ac(VHT20) Mode Ch36 AV

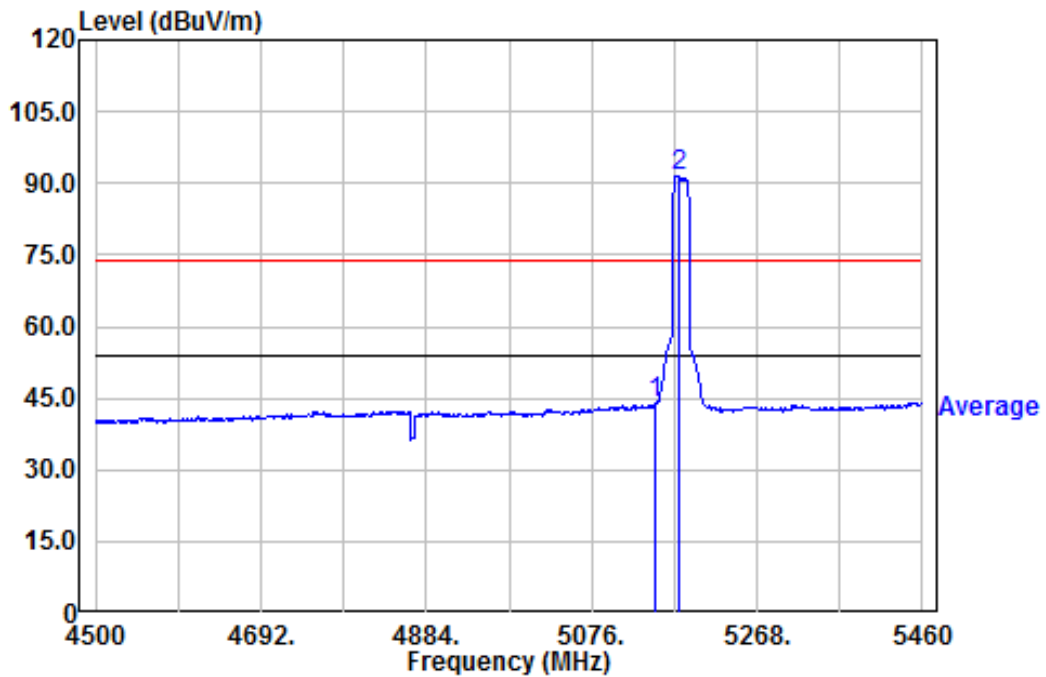

Chain0+1 : Restricted Band Bandedge @ 802.11ac(VHT20) Mode Ch48 PK

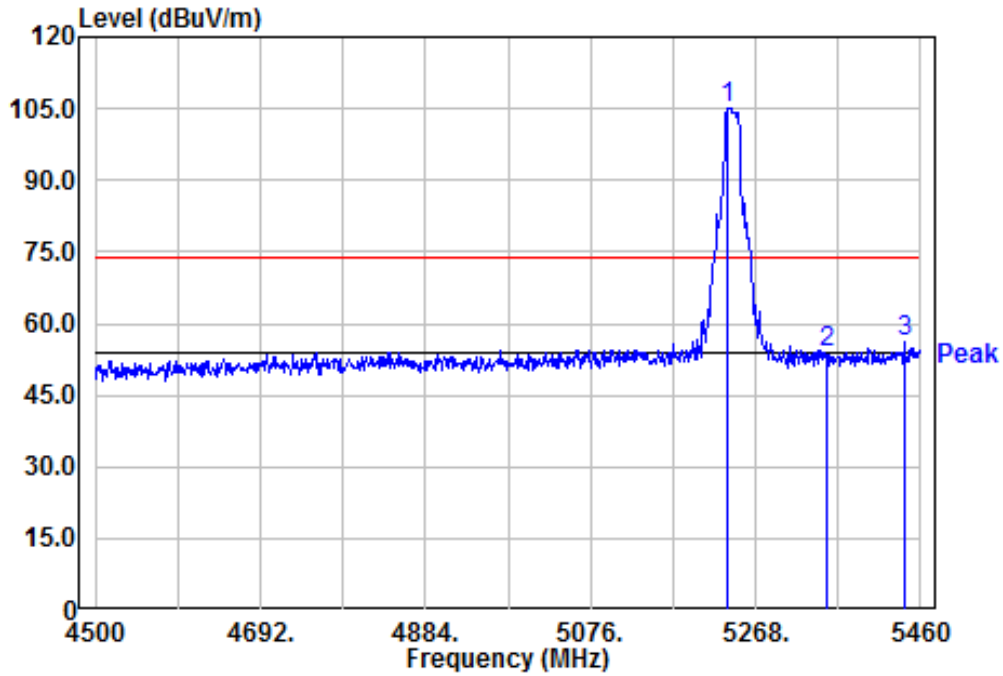

Chain0+1 : Restricted Band Bandedge @ 802.11ac(VHT20) Mode Ch48 AV

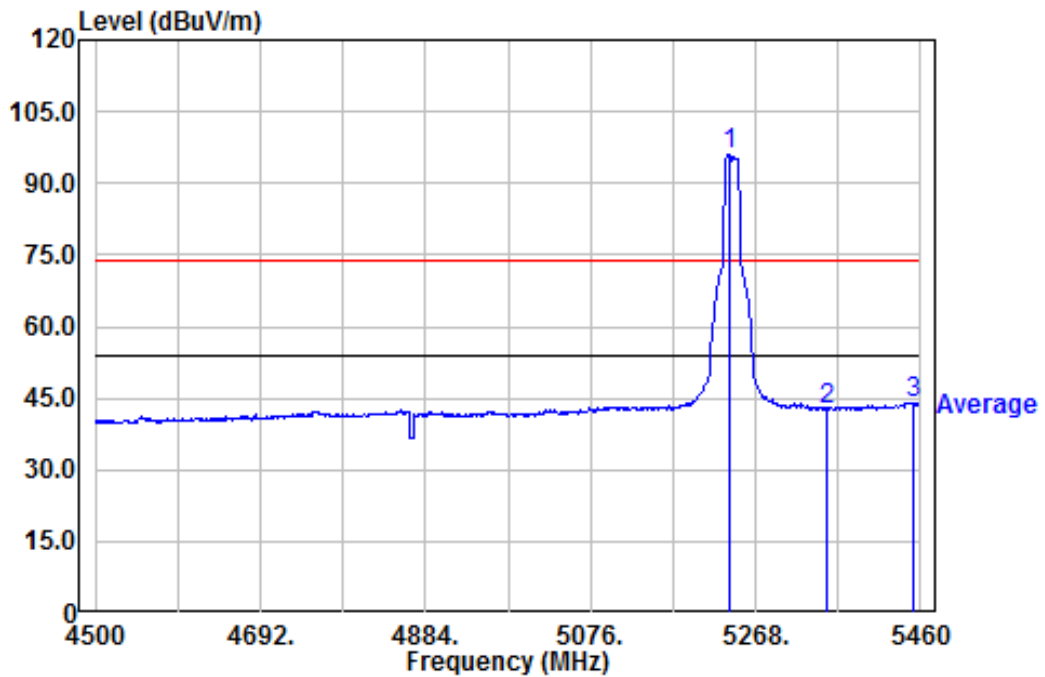

Chain0+1 : Restricted Band Bandedge @ 802.11ac(VHT40) Mode Ch38 PK

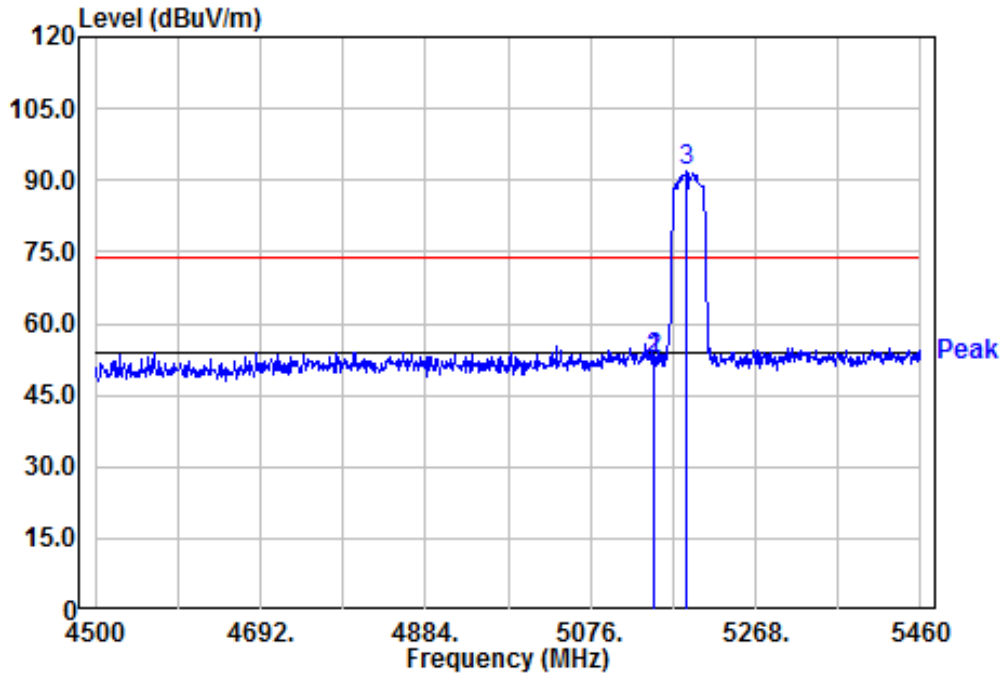

Chain0+1 : Restricted Band Bandedge @ 802.11ac(VHT40) Mode Ch38 AV

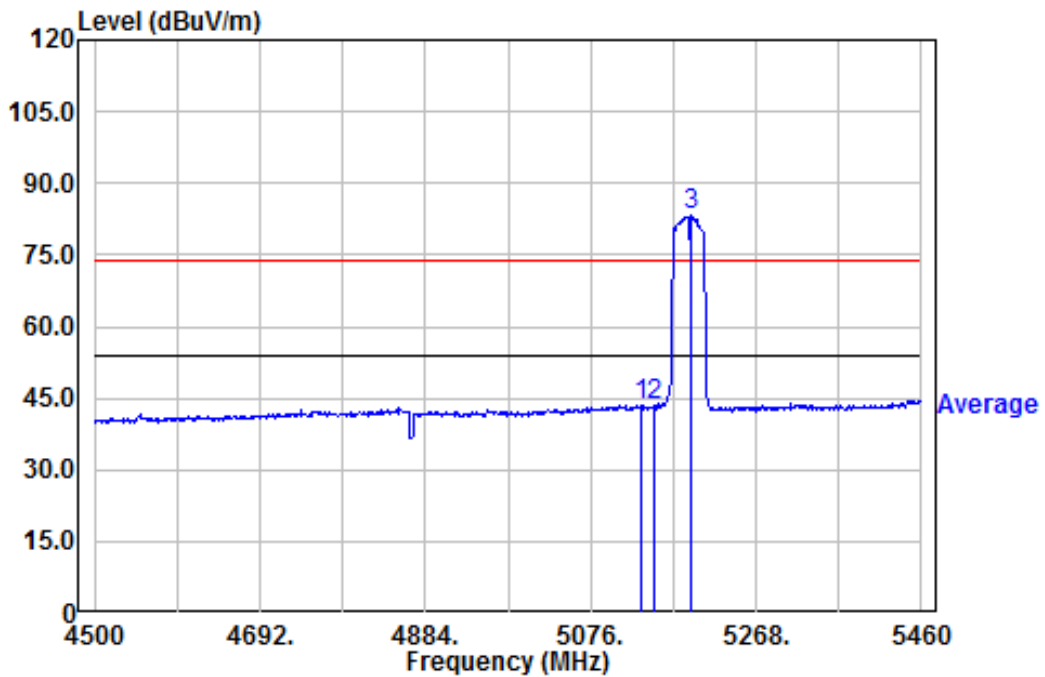

Chain0+1 : Restricted Band Bandedge @ 802.11ac(VHT40) Mode Ch46 PK

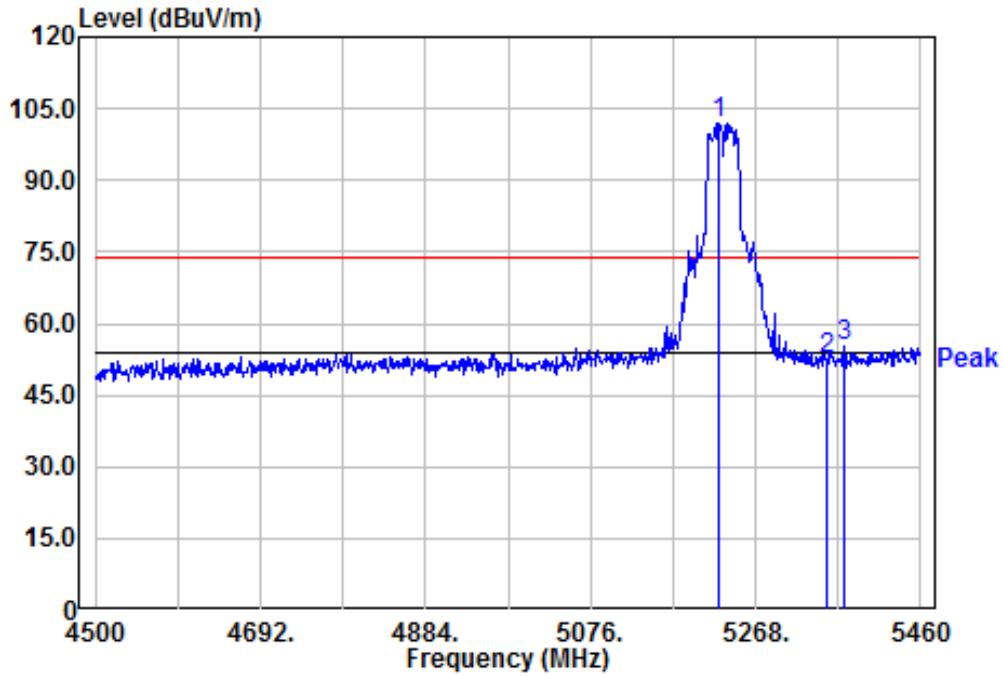

Chain0+1 : Restricted Band Bandedge @ 802.11ac(VHT40) Mode Ch46 AV

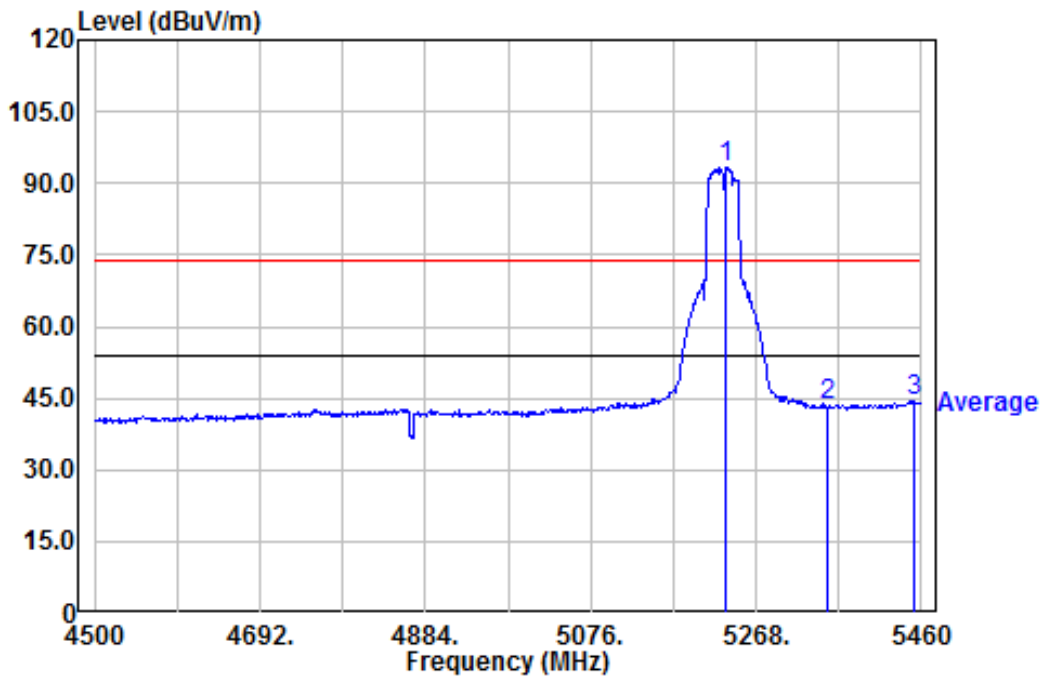

TEST REPORT

Chain0+1 : Restricted Band Bandedge @ 802.11ac(VHT80) Mode Ch42 PK

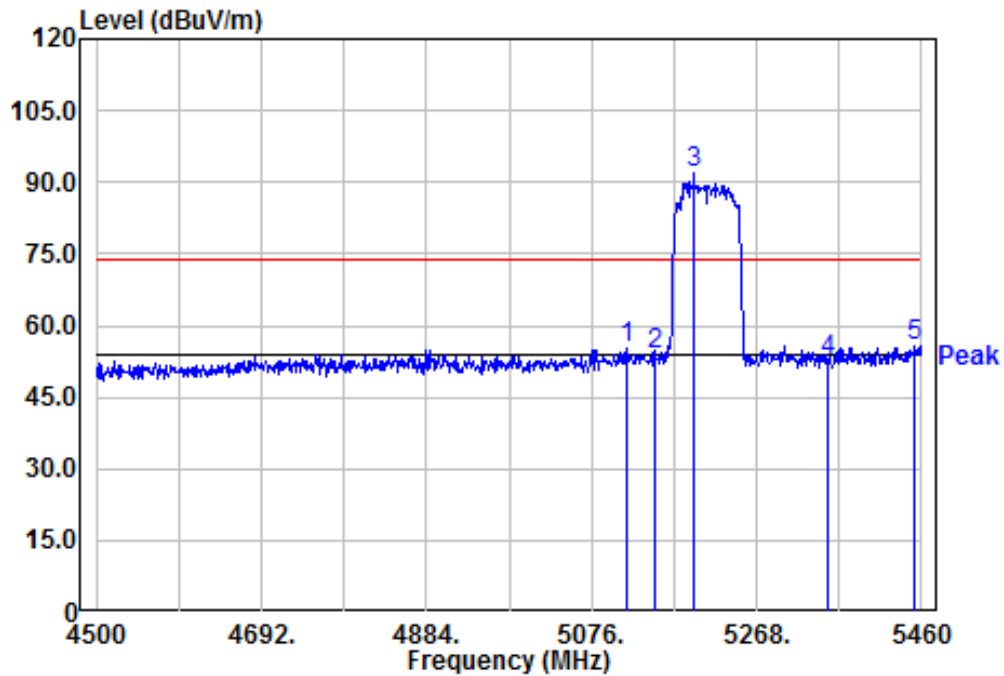

Chain0+1 : Restricted Band Bandedge @ 802.11ac(VHT80) Mode Ch42 AV

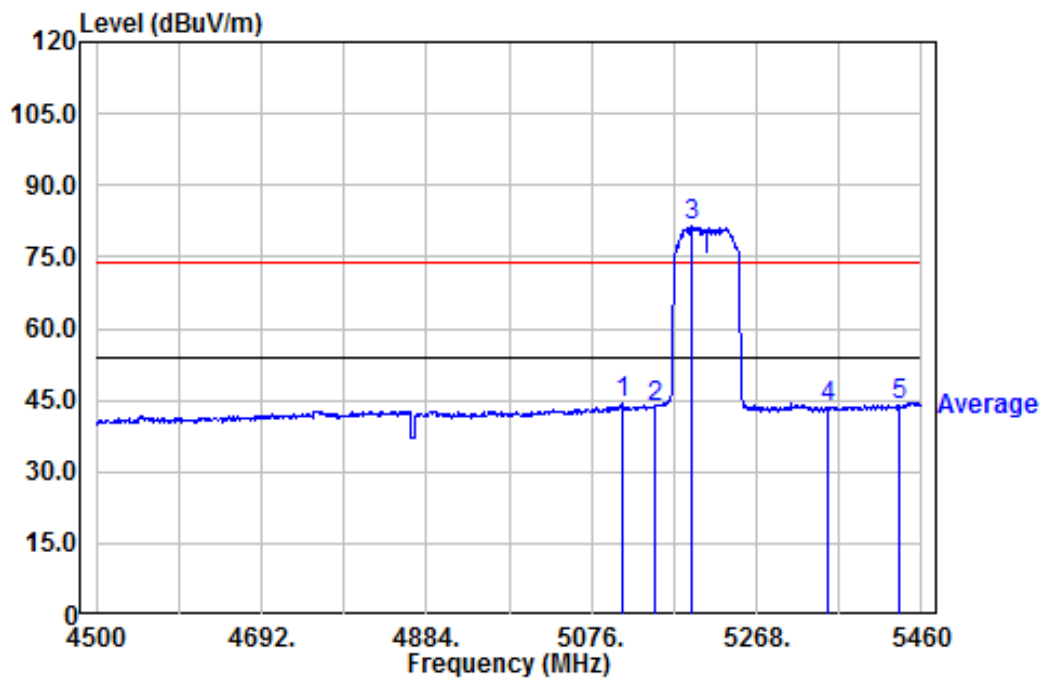

Chain0+1 : Out-of-band emission limits for U-NII-3 @ mode 802.11a Ch149

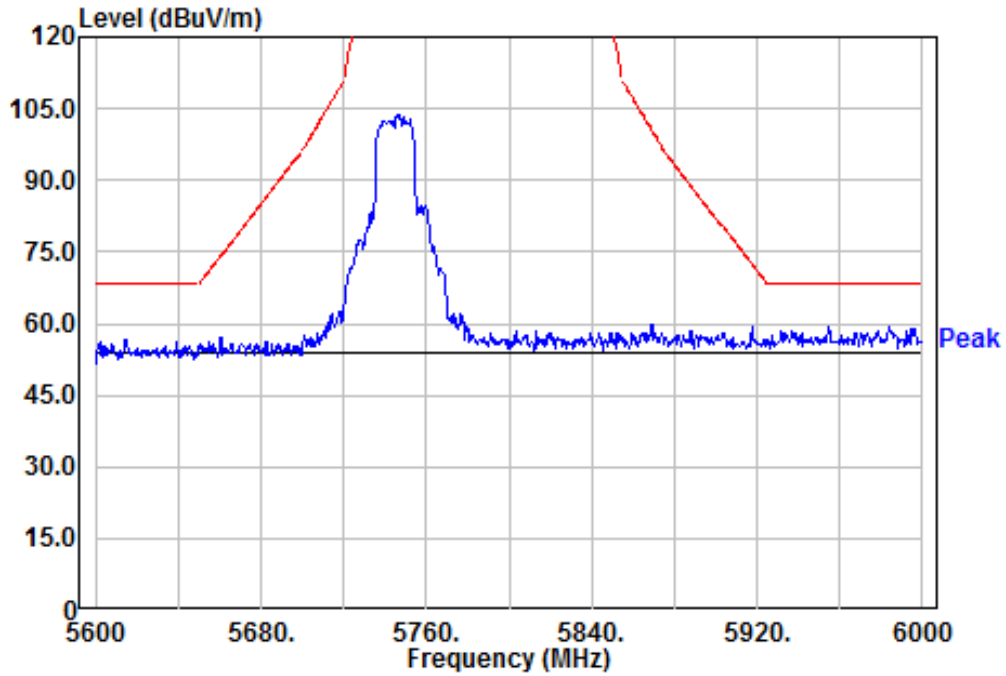

Chain0+1 : Out-of-band emission limits for U-NII-3 @ mode 802.11a Ch157

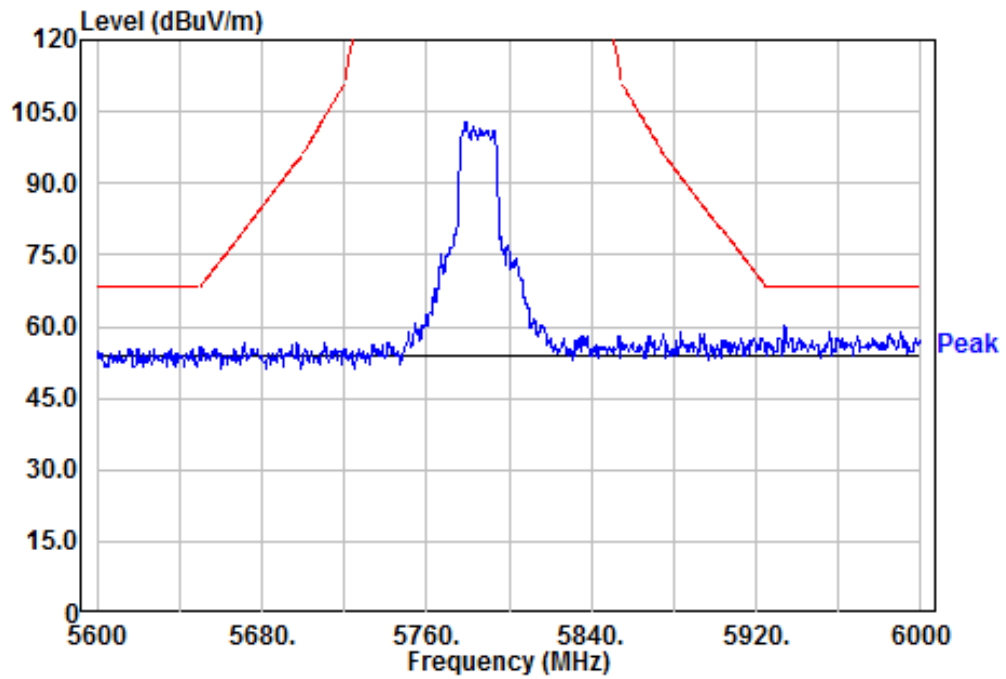

Chain0+1 : Out-of-band emission limits for U-NII-3 @ mode 802.11a Ch165

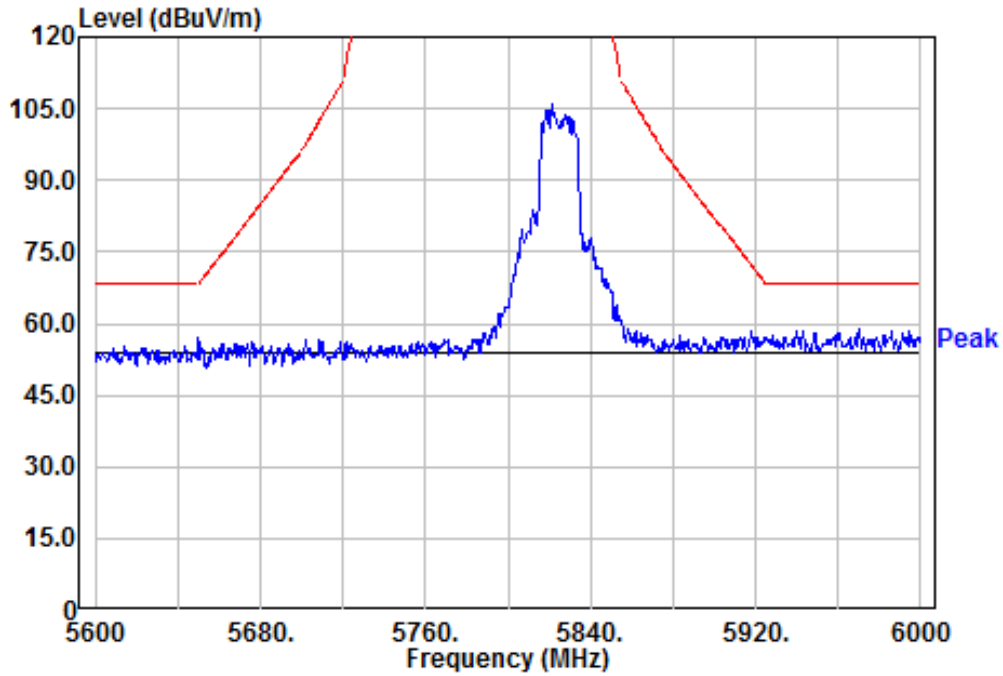

Chain0+1 : Out-of-band emission limits for U-NII-3 @ mode 802.11ac(VHT20) Ch149

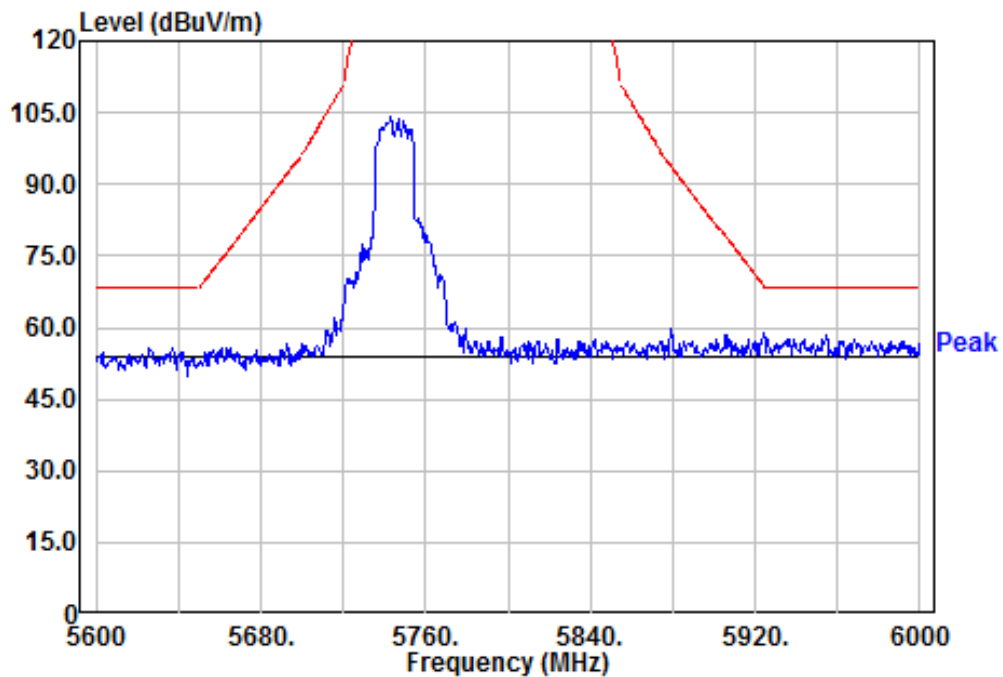

Chain0+1 : Out-of-band emission limits for U-NII-3 @ mode 802.11ac(VHT20) Ch157

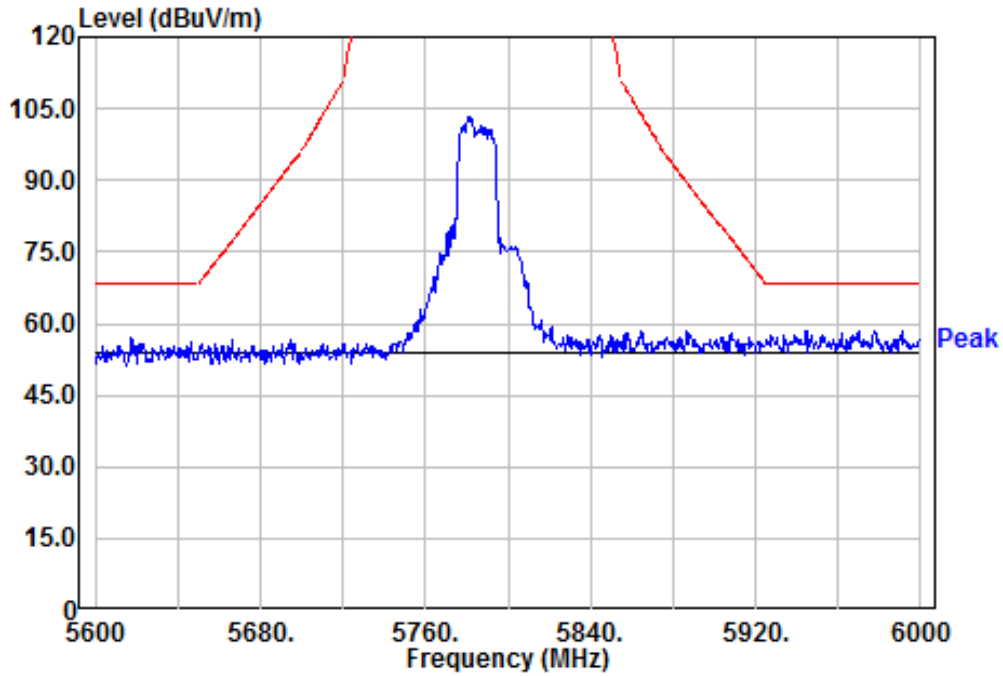

Chain0+1 : Out-of-band emission limits for U-NII-3 @ mode 802.11ac(VHT20) Ch165

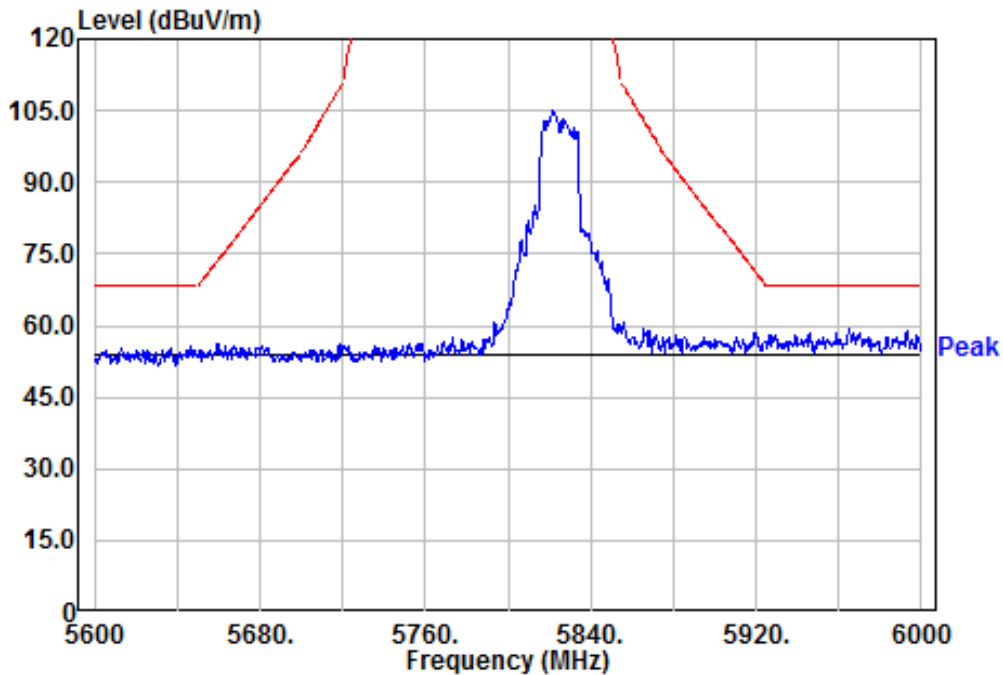

Chain0+1 : Out-of-band emission limits for U-NII-3 @ mode 802.11ac(VHT40) Ch151

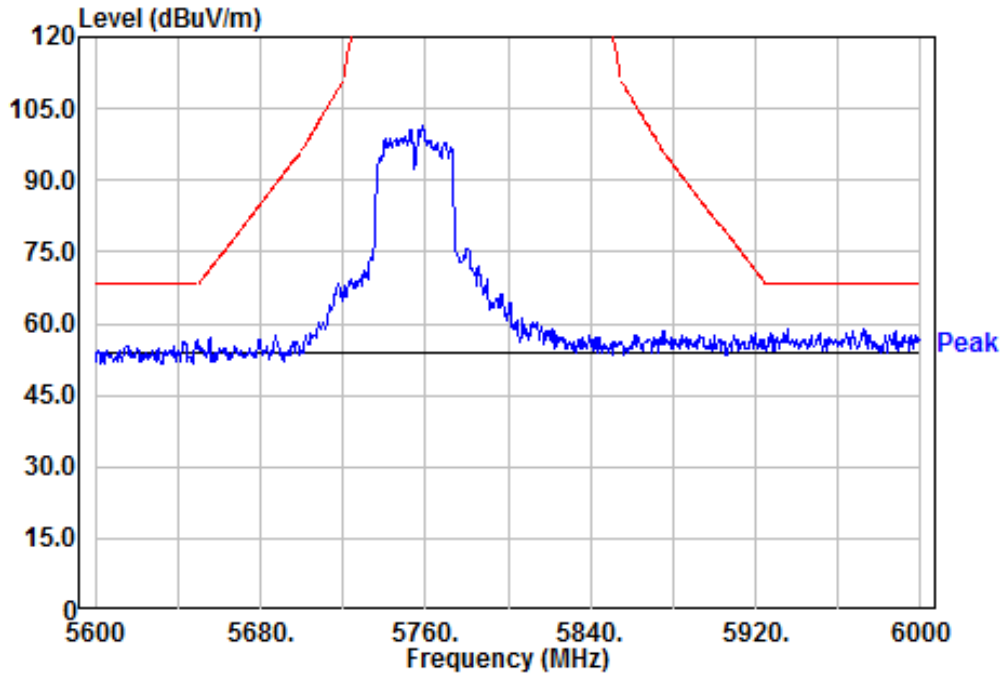

Chain0+1 : Out-of-band emission limits for U-NII-3 @ mode 802.11ac(VHT40) Ch159

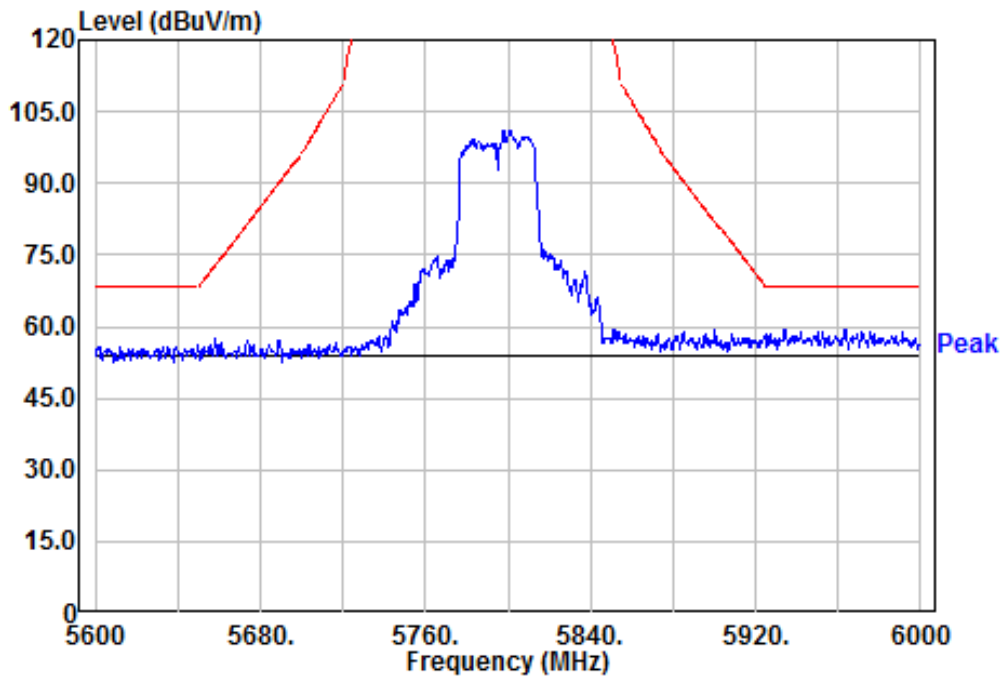

Chain0+1 : Out-of-band emission limits for U-NII-3 @ mode 802.11ac(VHT80) Ch155

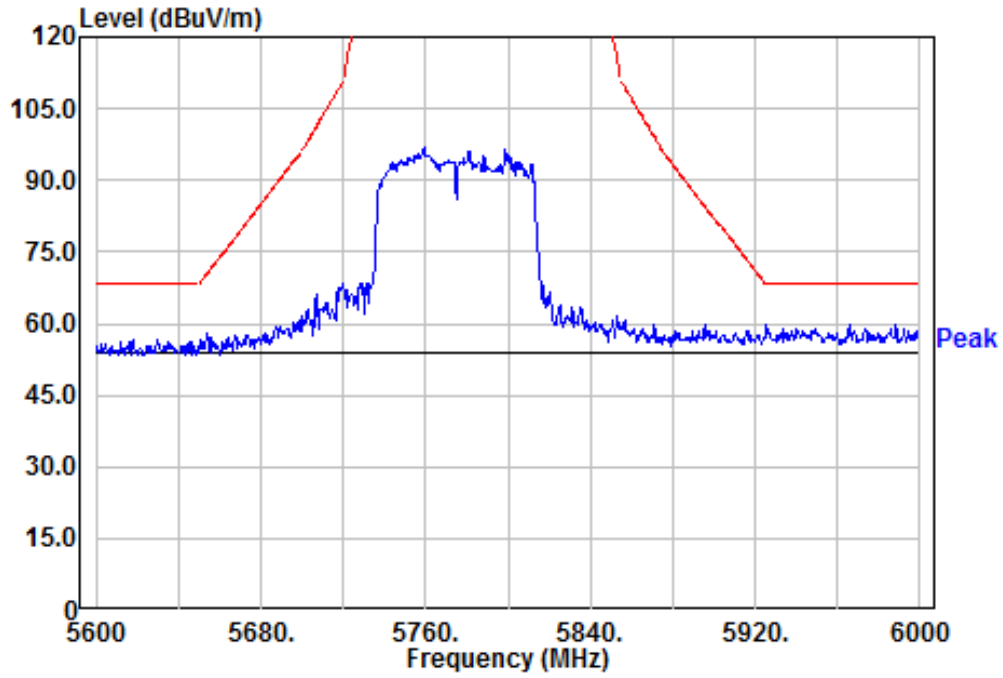

5. AC Power Line Conducted Emission

5.1 Measuring instrument setting

Receiver Function	Setting
Detector	QP
Start frequency	0.15MHz
Stop frequency	30MHz
IF bandwidth	9 kHz
Attenuation	10dB

5.2 Test Procedure

Step 1	Configure the EUT according to ANSI C63.10:2013. The EUT or host of EHT has to be placed 0.4 meter far from the conducting wall of the shielding room and at least 80 centimeters from any other grounded conducting surface.
Step 2	Connect EUT or host of EUT to the power mains through a line impedance stabilization network.
Step 3	All the companion devices are connected to the other LISN. The LISN should provide 50Uh/50ohms coupling impedance.
Step 4	The frequency range from 150 kHz to 30MHz was searched.
Step 5	Set the test-receiver system to peak detector and specified bandwidth with maximum hold mode.
Step 6	The measurement has to be done between each power line and ground at the power terminal.

5.3 Test Diagram

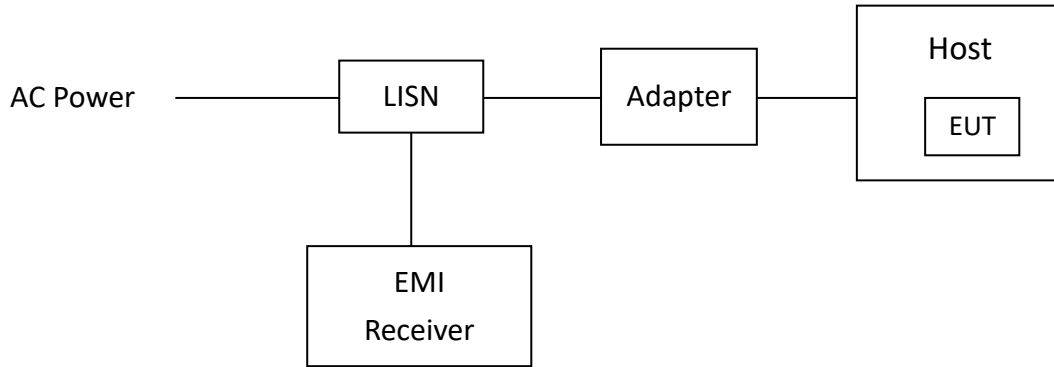

5.4 Limit

Frequency (MHz)	Conducted Limit (dBuV)	
	Q.P.	Ave.
0.15~0.50	66 – 56	56 – 46
0.50~5.00	56	46
5.00~30.0	60	50

TEST REPORT

7.5 Test Results

Model No.:	FBP205
Host :	64428

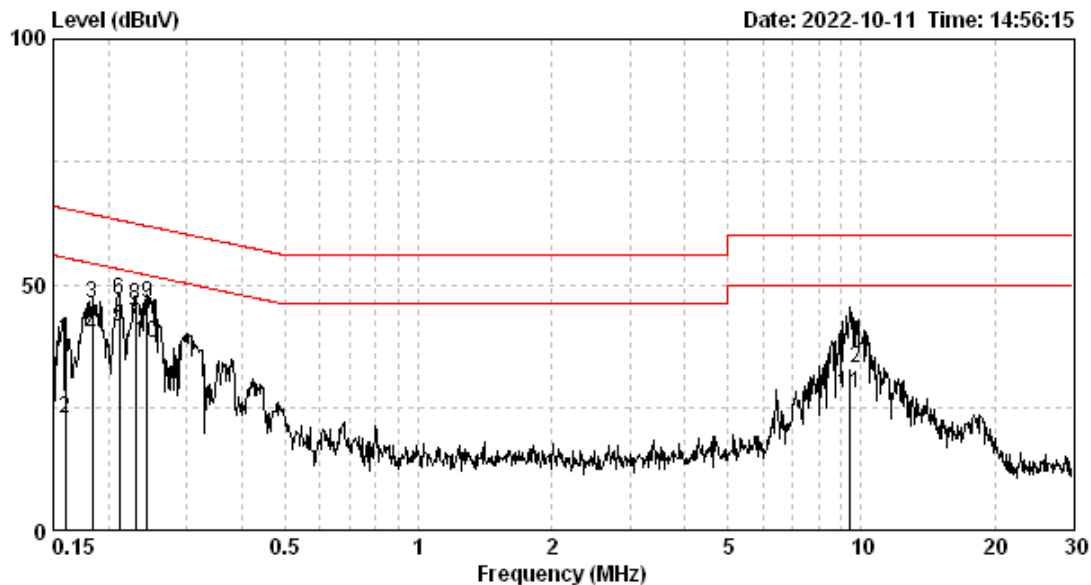

Test voltage :AC 120V/60Hz
 Temp. / R.H. :22°C / 60%
 Atmospheric pressure :1007 hPa

Phase	Frequency (MHz)	Corr. Factor (dB)	Reading QP (dBuV)	Level QP (dBuV)	Limit QP (dBuV)	Reading AV (dBuV)	Level AV (dBuV)	Limit AV (dBuV)	Margin (dB)	
									QP	AV
LINE	0.160	9.65	29.33	38.98	65.47	12.90	22.56	55.47	-26.49	-32.91
LINE	0.183	9.65	36.54	46.19	64.33	29.89	39.54	54.33	-18.14	-14.79
LINE	0.212	9.65	37.16	46.81	63.14	31.76	41.41	53.14	-16.33	-11.73
LINE	0.230	9.65	36.16	45.81	62.44	32.05	41.70	52.44	-16.63	-10.74
LINE	0.244	9.65	36.50	46.16	61.95	28.47	38.13	51.95	-15.79	-13.83
LINE	9.451	9.78	23.19	32.97	60.00	17.93	27.72	50.00	-27.03	-22.28

Remark:

1. Corr. Factor (dB) = LISN Factor (dB) + Cable Loss (dB)
2. Level (dBuV) = Corr. Factor (dB) + Reading (dBuV)
3. Margin (dB) = Level (dBuV) – Limit (dBuV)

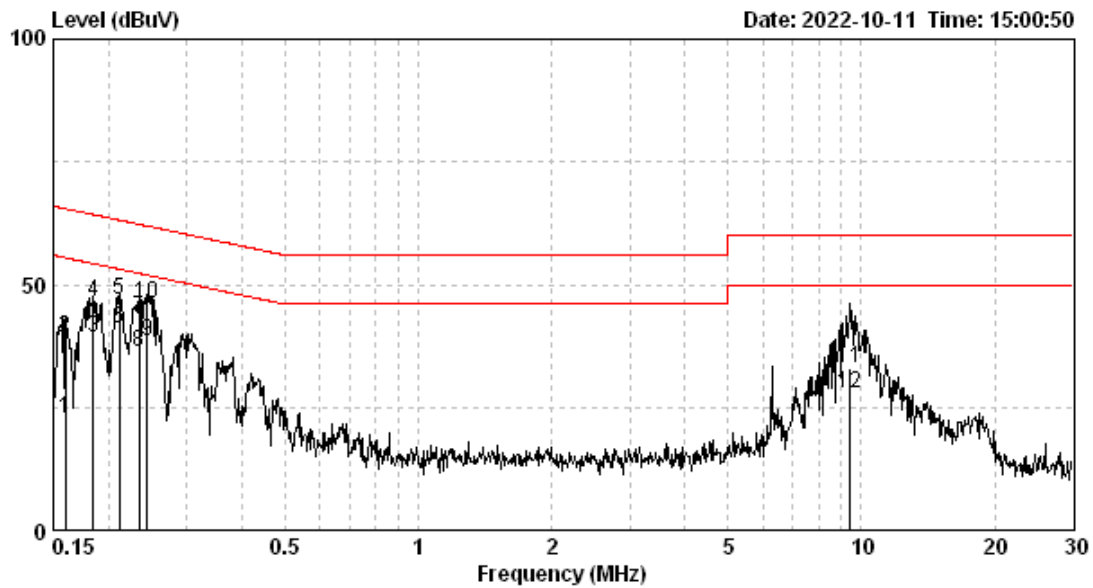

Test voltage :AC 120V/60Hz
 Temp. / R.H. :22°C / 60%
 Atmospheric pressure :1007 hPa

Phase	Frequency (MHz)	Corr. Factor (dB)	Reading QP (dBuV)	Level QP (dBuV)	Limit QP (dBuV)	Reading AV (dBuV)	Level AV (dBuV)	Limit AV (dBuV)	Margin (dB)	
									QP	AV
NEUTRAL	0.160	9.66	29.62	39.28	65.47	12.89	22.56	55.47	-26.19	-32.91
NEUTRAL	0.184	9.66	36.86	46.52	64.28	29.55	39.22	54.28	-17.76	-15.07
NEUTRAL	0.212	9.66	37.05	46.71	63.14	31.34	41.00	53.14	-16.43	-12.14
NEUTRAL	0.234	9.66	33.44	43.10	62.30	26.62	36.28	52.30	-19.20	-16.02
NEUTRAL	0.244	9.66	36.67	46.33	61.95	28.66	38.33	51.95	-15.62	-13.63
NEUTRAL	9.451	9.81	23.22	33.03	60.00	17.94	27.75	50.00	-26.97	-22.25

Remark:

1. Corr. Factor (dB) = LISN Factor (dB) + Cable Loss (dB)
2. Level (dBuV) = Corr. Factor (dB) + Reading (dBuV)
3. Margin (dB) = Level (dBuV) – Limit (dBuV)

Appendix A: Test equipment list

Test Equipment/ Test site	Brand	Model No.	Serial No.	Calibration Date	Next Calibration Date
EMI Test Receiver	Rohde & Schwarz	ESR7	101822	2022/08/09	2023/08/08
Signal Analyzer	Agilent	N9030A	MY51380492	2022/08/09	2023/08/08
Active Loop Antenna	SCHWARZBECK MESS-ELEKTRONIC	FMZB1519	1519-067	2022/04/13	2023/04/12
Broadband Antenna	SHWARZBECK	VULB 9168	9168-172	2022/01/20	2023/01/19
Horn Antenna	EMCO	BBHA 9120 D	9120D-456	2022/01/21	2023/01/20
Horn Antenna	SCHWARZBECK	BBHA 9170	BBHA9170159	2021/04/08	2024/04/07
Broadband Amplifier	SGH	SGH118(45dB)	20220105-1	2022/01/07	2023/01/06
Pre-amplifier	SGH	SGH184	20201124-1	2021/12/06	2022/12/05
Power Meter	Anritsu	ML2495A	0844001	2022/07/04	2023/07/03
Power Sensor	Anritsu	MA2491A	031543	2022/03/07	2023/03/06
966-2(A) Cable	SUHNER	SMA / EX 100	N/A	2022/03/04	2023/03/03
966-2(B) Cable	SUHNER	SUCOFLEX 104P	CB0005	2022/03/04	2023/03/03
966-2 Cable	SUHNER	SUCOFLEX 104P	9403/4P	2021/11/30	2022/11/29
966-2_3m Semi-Anechoic Chamber	966_2	CEM-966_2	N/A	2022/01/14	2023/01/13
Hight Pass Filter	Reactel	7HS-3G/18G-S11	N/A	2022/05/25	2023/05/24
20dB Attenuator	Mini-Circuits	BW-S20W5+	N/A	2022/05/25	2023/05/24
Test software	Audix	e3	V9	NCR	NCR

Note: No Calibration Required (NCR).

Test Equipment	Brand	Model No.	Serial No.	Calibration Date	Next Calibration Date
EMI Test Receiver	R&S	ESCI	100018	2021/11/16	2022/11/15
LISN	R&S	ENV216	101160	2022/07/13	2023/07/12
CON-2 Cable	SUHNER	EMCCFD300-B M-NM-6000	170502	2022/04/29	2023/04/28
Test software	Audix	e3	V4.20040112L	NCR	NCR

Note: No Calibration Required (NCR).

Appendix B: Measurement Uncertainty

This uncertainty represents an expanded uncertainty expressed at approximately the 95 % confidence level using a coverage factor of $k=2$.

Item	Uncertainty
Vertically polarized radiated disturbances from 30MHz~1GHz in a semi-anechoic chamber at a distance of 3m	5.16 dB
Horizontally polarized radiated disturbances from 30MHz~1GHz in a semi-anechoic chamber at a distance of 3m	5.02 dB
Radiated disturbances from 1GHz~18GHz in a semi-anechoic chamber at a distance of 3m	5.17 dB
Vertically polarized Radiated disturbances from 18GHz~26.5GHz in a semi-anechoic chamber at a distance of 1m	2.39 dB
Horizontally polarized Radiated disturbances from 18GHz~26.5GHz in a semi-anechoic chamber at a distance of 1m	2.39 dB
Vertically polarized Radiated disturbances from 26.5GHz~40GHz in a semi-anechoic chamber at a distance of 1m	2.39 dB
Horizontally polarized Radiated disturbances from 26.5GHz~40GHz in a semi-anechoic chamber at a distance of 1m	2.39 dB
Radiated disturbances from 9kHz~30MHz in a semi-anechoic chamber at a distance of 3m	3.70 dB
Emission on the Band Edge Test	4.32 dB
Minimum Emission Bandwidth	7.78 %
Maximum Conducted Output Power	1.27 dB
Power Spectral Density	1.27 dB
AC Power Line Conducted Emission	3.08 dB