

Chain0 : Emission Bandwidth-26dB @ 802.11ac(VHT20) Mode Ch149

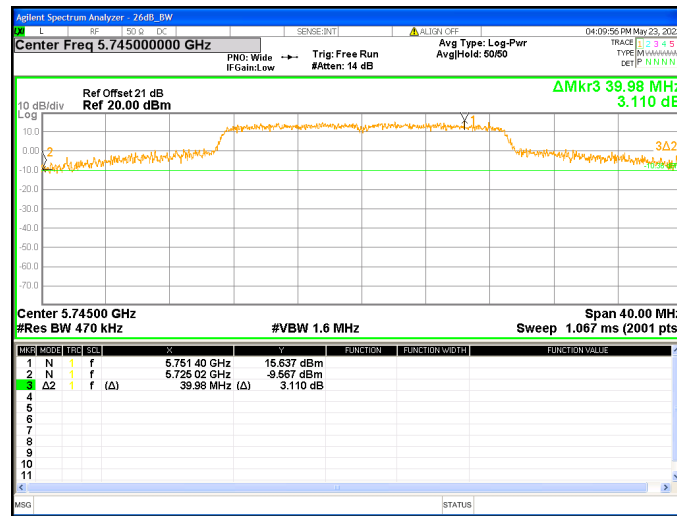

Chain0 : Emission Bandwidth-26dB @ 802.11ac(VHT20) Mode Ch157

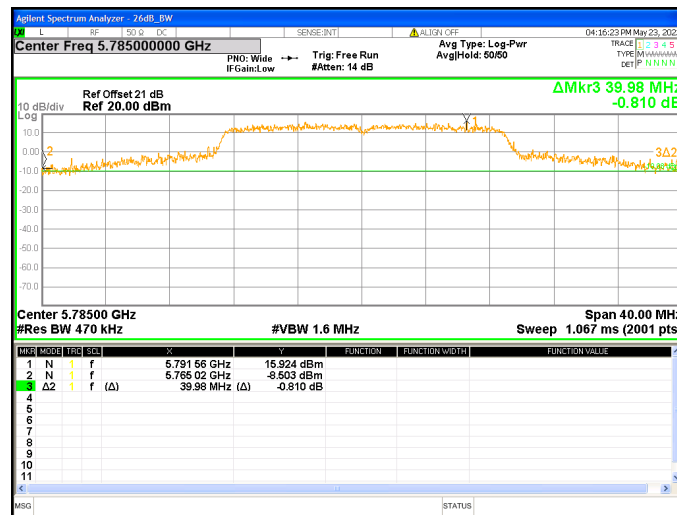

Chain0 : Emission Bandwidth-26dB @ 802.11ac(VHT20) Mode Ch165

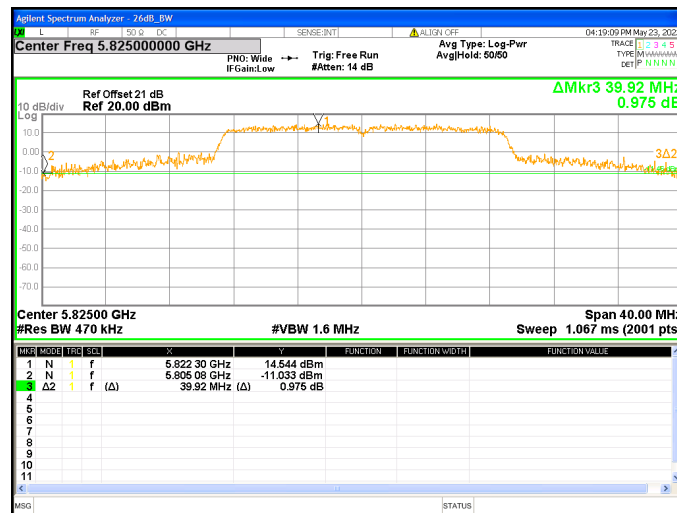

Chain1 : Emission Bandwidth-26dB @ 802.11ac(VHT20) Mode Ch36



Chain1 : Emission Bandwidth-26dB @ 802.11ac(VHT20) Mode Ch44



Chain1 : Emission Bandwidth-26dB @ 802.11ac(VHT20) Mode Ch48

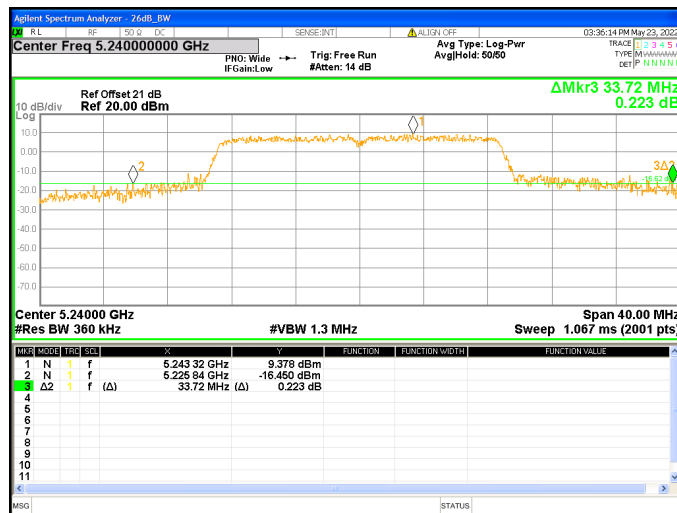

Chain1 : Emission Bandwidth-26dB @ 802.11ac(VHT20) Mode Ch149

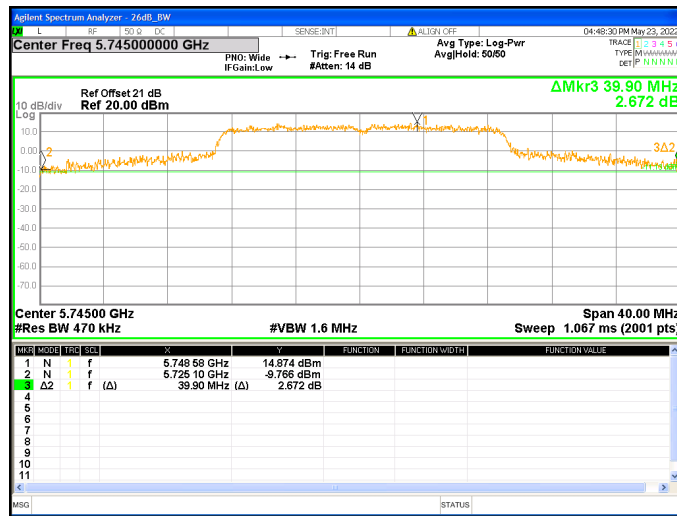

Chain1 : Emission Bandwidth-26dB @ 802.11ac(VHT20) Mode Ch157

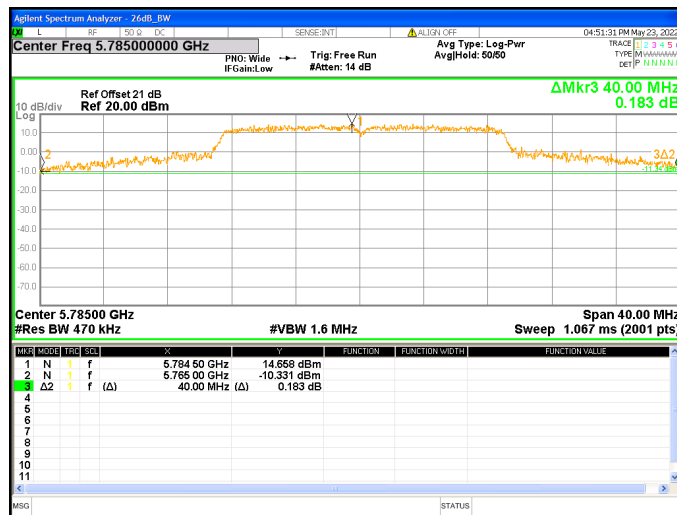

Chain1 : Emission Bandwidth-26dB @ 802.11ac(VHT20) Mode Ch165

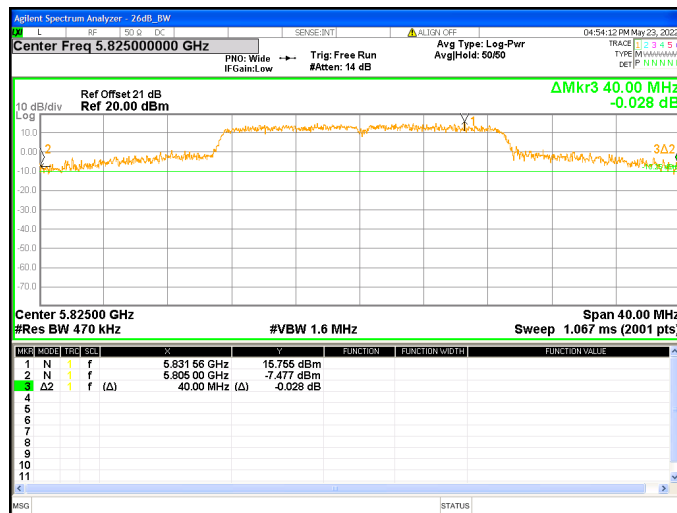

Chain0 : Emission Bandwidth-26dB @ 802.11ac(VHT40) Mode Ch38

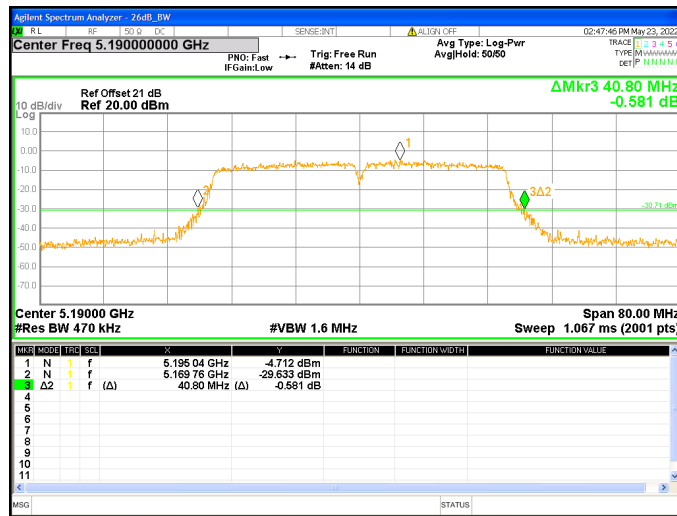

Chain0 : Emission Bandwidth-26dB @ 802.11ac(VHT40) Mode Ch46

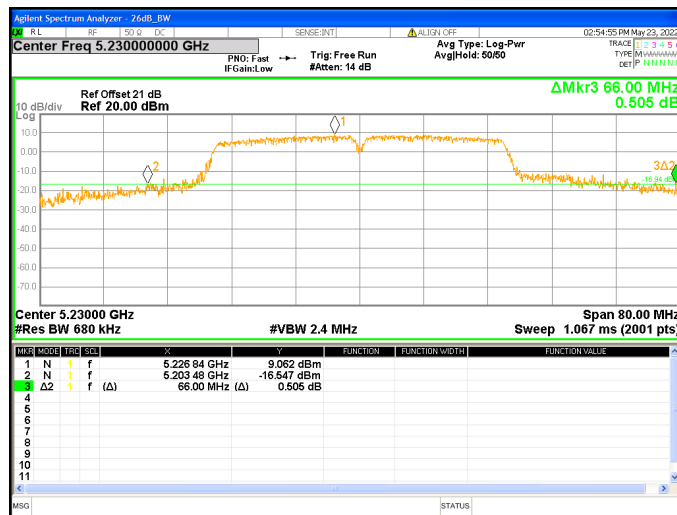

Chain0 : Emission Bandwidth-26dB @ 802.11ac(VHT40) Mode Ch151

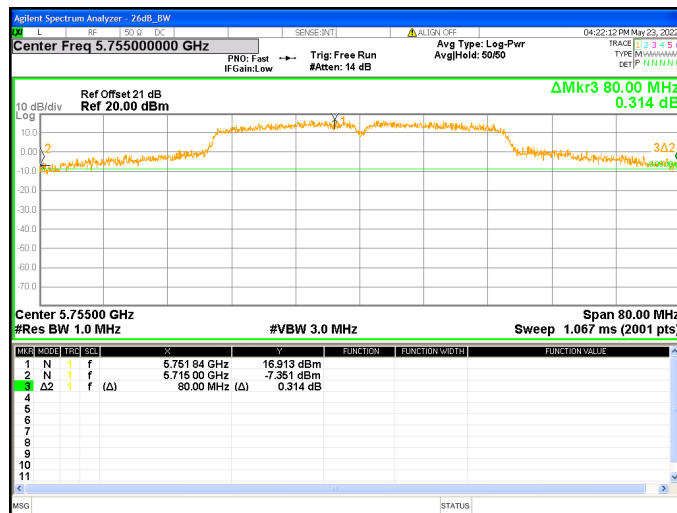

Chain0 : Emission Bandwidth-26dB @ 802.11ac(VHT40) Mode Ch159

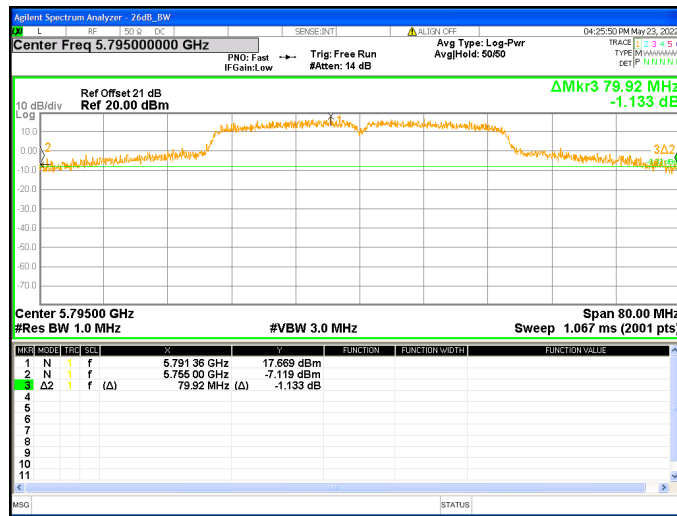

Chain1 : Emission Bandwidth-26dB @ 802.11ac(VHT40) Mode Ch38

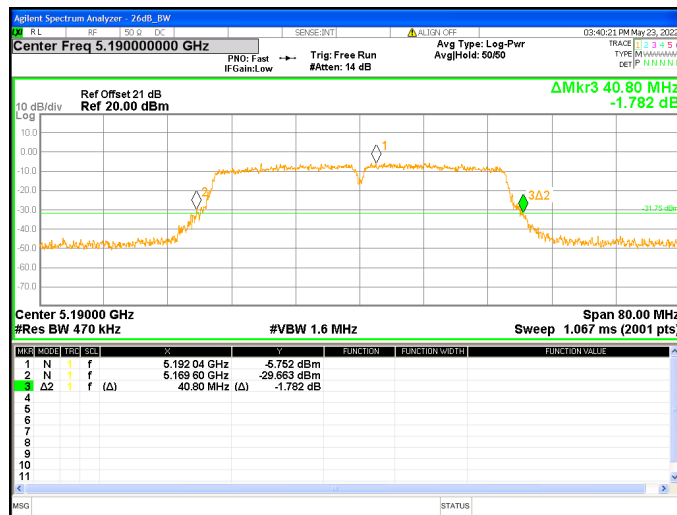

Chain1 : Emission Bandwidth-26dB @ 802.11ac(VHT40) Mode Ch46



Chain1 : Emission Bandwidth-26dB @ 802.11ac(VHT40) Mode Ch151

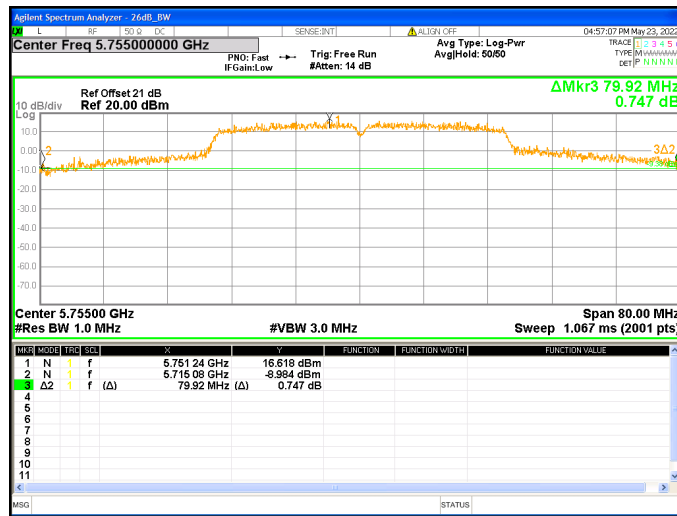

Chain1 : Emission Bandwidth-26dB @ 802.11ac(VHT40) Mode Ch159

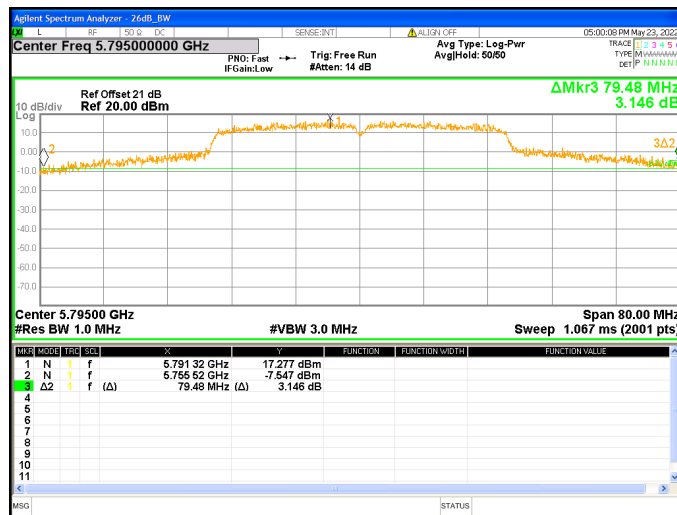

Chain0 : Emission Bandwidth-26dB @ 802.11ac(VHT80) Mode Ch42



Chain0 : Emission Bandwidth-26dB @ 802.11ac(VHT80) Mode Ch155

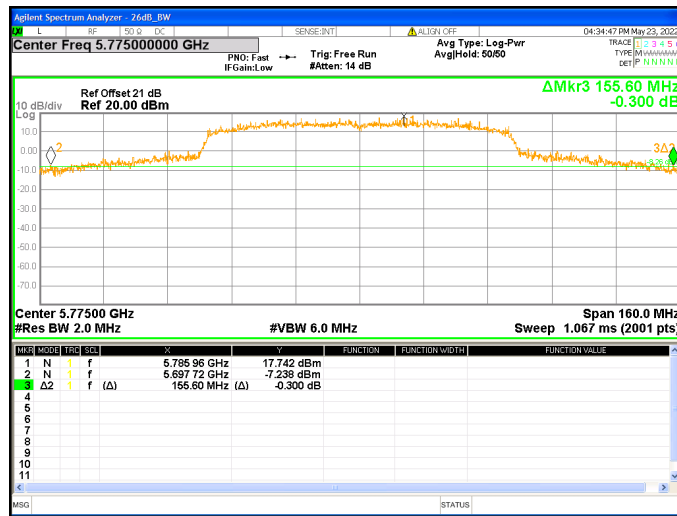

Chain1 : Emission Bandwidth-26dB @ 802.11ac(VHT80) Mode Ch42

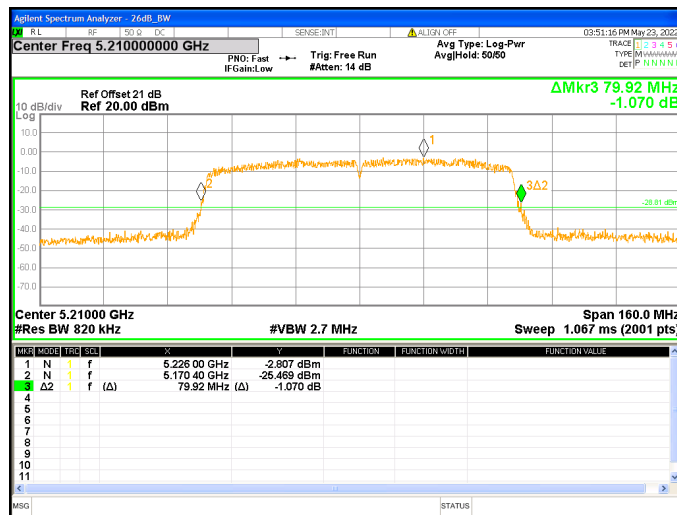

Chain1 : Emission Bandwidth-26dB @ 802.11ac(VHT80) Mode Ch155

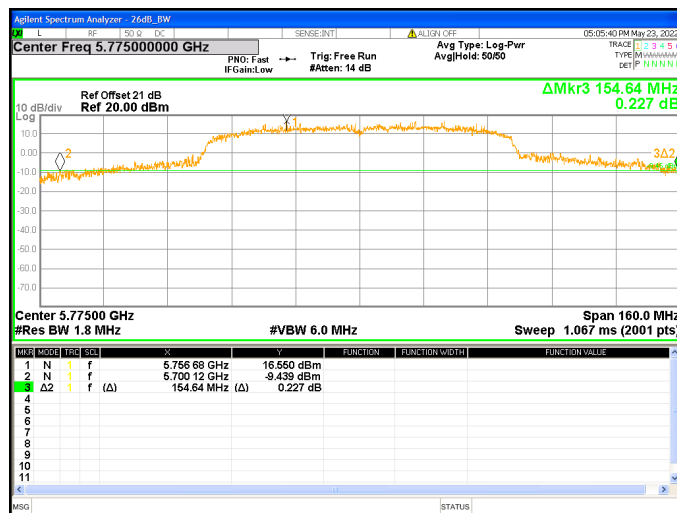

TEST REPORT

Temperature (°C) :	24
Relative Humidity (%) :	63
Test date :	2022/05/23
Host 1 :	67401

Mode	Channel	Frequency (MHz)	6dB Bandwidth (MHz)	Limit (MHz)	Result
802.11a Chain0	149	5745	16.36	>0.5	Pass
	157	5785	16.31		Pass
	165	5825	16.29		Pass
802.11a Chain1	149	5745	15.06	>0.5	Pass
	157	5785	16.34		Pass
	165	5825	15.95		Pass
802.11ac(VHT20) Chain0	149	5745	17.54	>0.5	Pass
	157	5785	17.48		Pass
	165	5825	16.95		Pass
802.11ac(VHT20) Chain1	149	5745	17.56	>0.5	Pass
	157	5785	16.97		Pass
	165	5825	17.52		Pass
802.11ac(VHT40) Chain0	151	5755	31.63	>0.5	Pass
	159	5795	33.80		Pass
802.11ac(VHT40) Chain1	151	5755	35.01	>0.5	Pass
	159	5795	35.03		Pass
802.11ac(VHT80) Chain0	155	5775	67.58	>0.5	Pass
802.11ac(VHT80) Chain1	155	5775	72.44	>0.5	Pass

Chain0 : 6dB Bandwidth @ 802.11a Mode Ch149

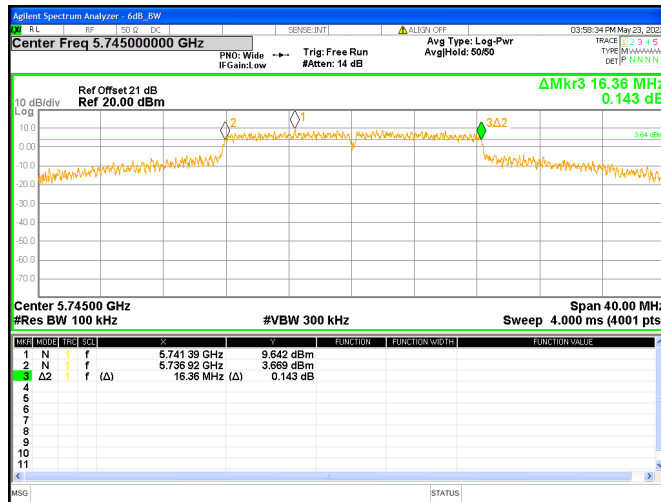

Chain0 : 6dB Bandwidth @ 802.11a Mode Ch157



Chain0 : 6dB Bandwidth @ 802.11a Mode Ch165

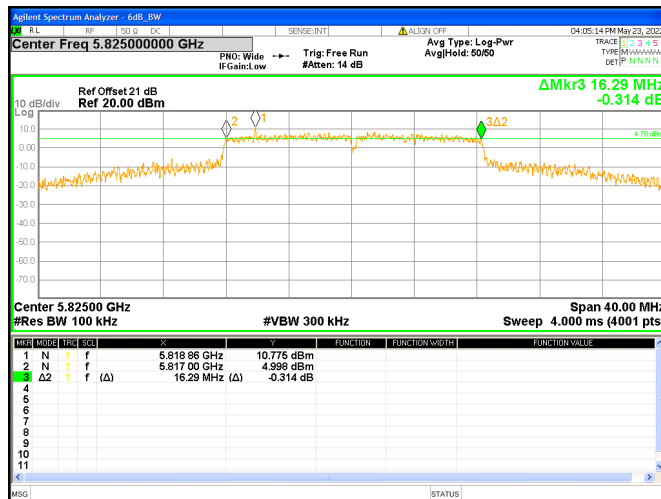

Chain1 : 6dB Bandwidth @ 802.11a Mode Ch149

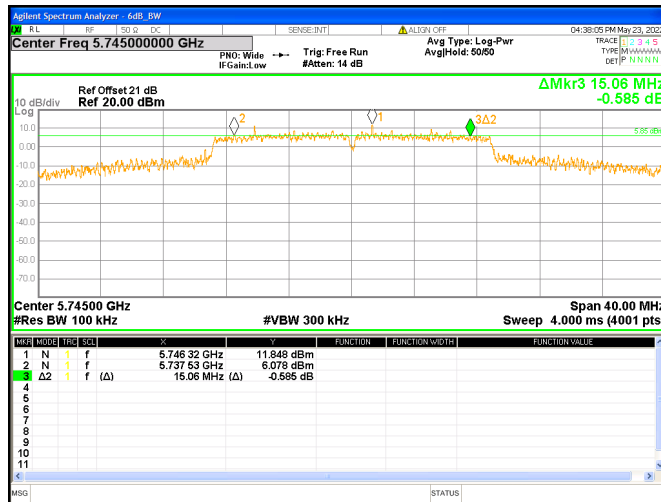

Chain1 : 6dB Bandwidth @ 802.11a Mode Ch157

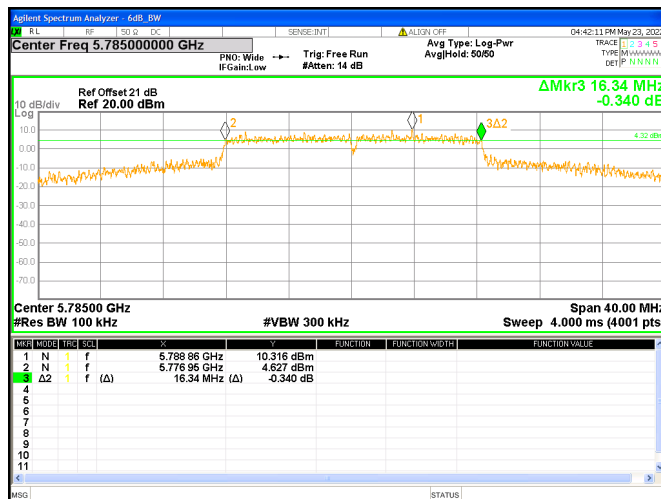

Chain1 : 6dB Bandwidth @ 802.11a Mode Ch165

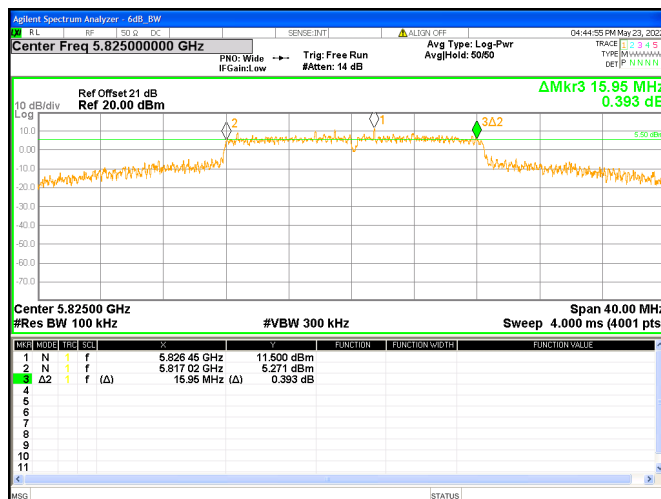

Chain0 : 6dB Bandwidth @ 802.11ac(VHT20) Mode Ch149

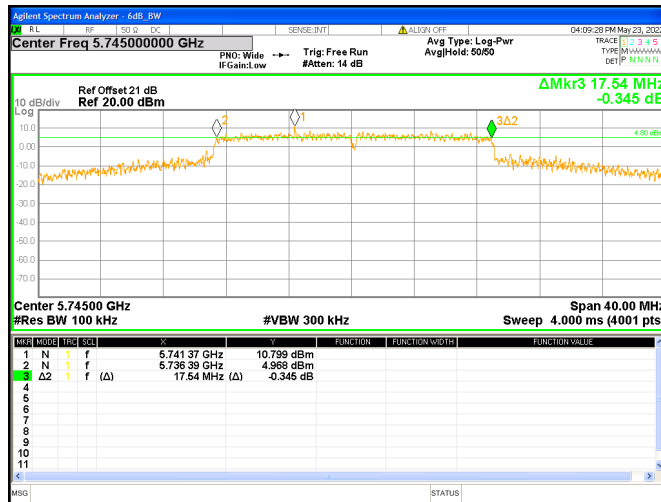

Chain0 : 6dB Bandwidth @ 802.11ac(VHT20) Mode Ch157

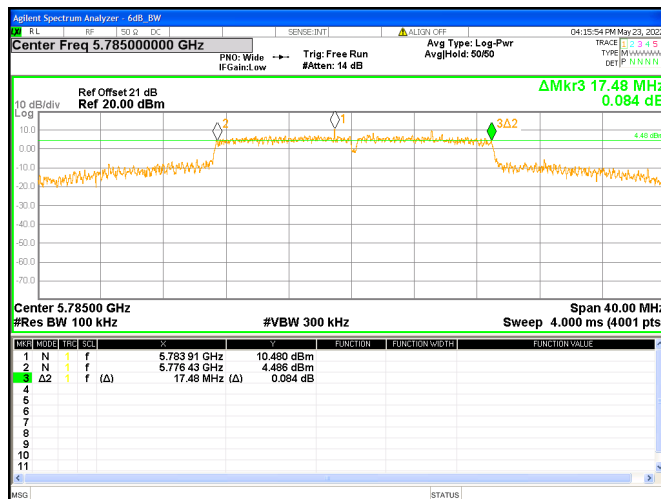

Chain0 : 6dB Bandwidth @ 802.11ac(VHT20) Mode Ch165

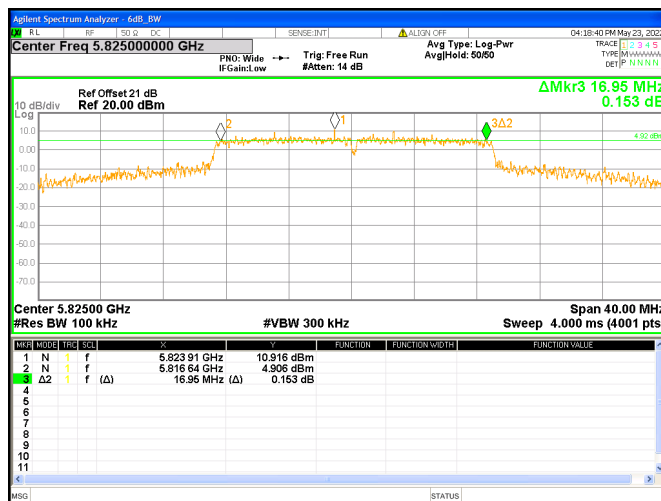

Chain1 : 6dB Bandwidth @ 802.11ac(VHT20) Mode Ch149

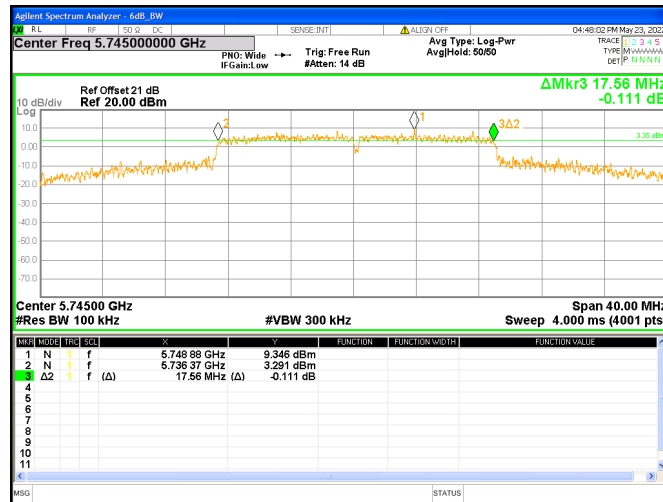

Chain1 : 6dB Bandwidth @ 802.11ac(VHT20) Mode Ch157

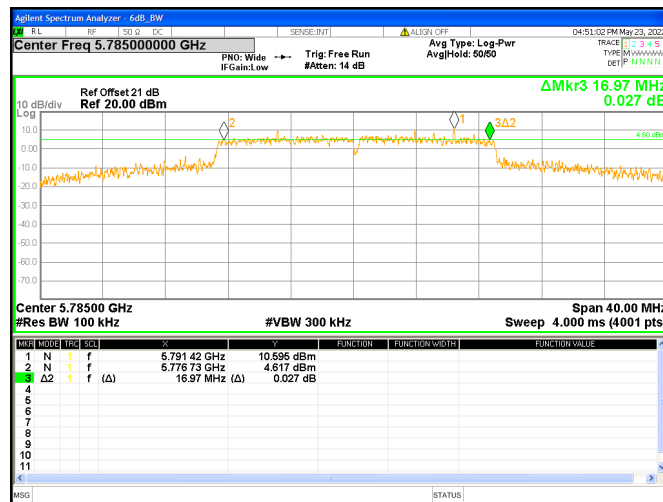

Chain1 : 6dB Bandwidth @ 802.11ac(VHT20) Mode Ch165



Chain0 : 6dB Bandwidth @ 802.11ac(VHT40) Mode Ch151

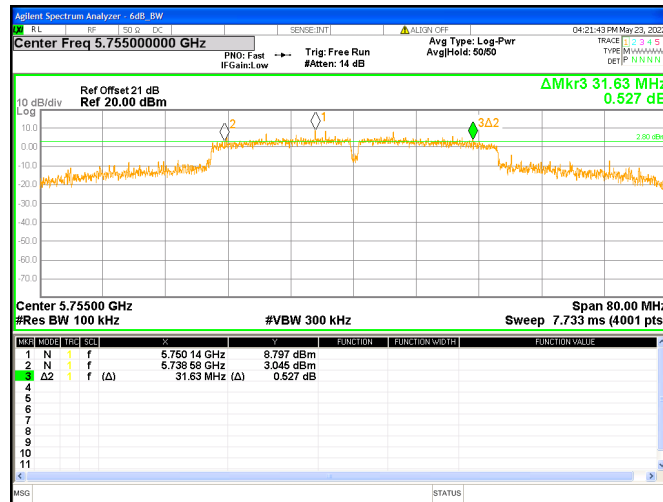

Chain0 : 6dB Bandwidth @ 802.11ac(VHT40) Mode Ch159

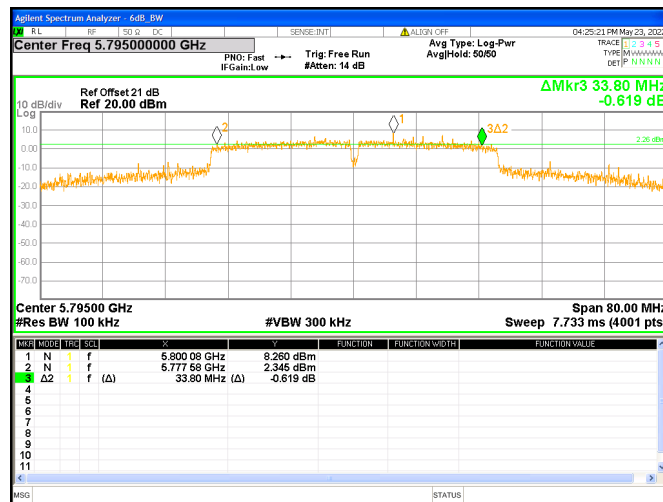

Chain1 : 6dB Bandwidth @ 802.11ac(VHT40) Mode Ch151



Chain1 : 6dB Bandwidth @ 802.11ac(VHT40) Mode Ch159

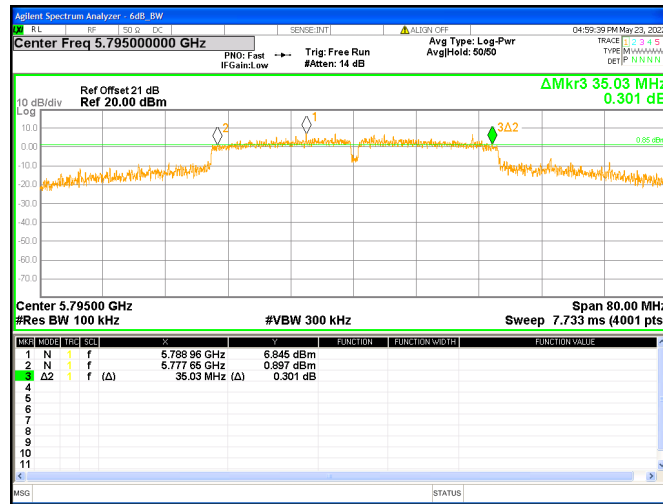

Chain0 : 6dB Bandwidth @ 802.11ac(VHT80) Mode Ch155



Chain1 : 6dB Bandwidth @ 802.11ac(VHT80) Mode Ch155



TEST REPORT

Temperature (°C) :	24
Relative Humidity (%) :	63
Test date :	2022/05/23
Host 1 :	67401

Mode	Channel	Frequency (MHz)	99% Bandwidth (MHz)	Upper Frequency (MHz)	Upper Limit (MHz)	Lower Frequency (MHz)	Lower Limit (MHz)
802.11a Chain0	36	5180	16.45				
	44	5220	16.53				
	48	5240	17.57	5249.14	5250		
	149	5745	27.57			5731.174	5725
	157	5785	25.96				
	165	5825	23.66				
802.11a Chain1	36	5180	16.48				
	44	5220	16.46				
	48	5240	16.48	5248.32	5250		
	149	5745	29.57			5730.96	5725
	157	5785	27.56				
	165	5825	27.30				
802.11ac (VHT20) Chain0	36	5180	17.62				
	44	5220	17.63				
	48	5240	18.00	5249.18	5250		
	149	5745	28.60			5731.3	5725
	157	5785	27.32				
	165	5825	25.08				
802.11ac (VHT20) Chain1	36	5180	17.64				
	44	5220	17.64				
	48	5240	17.87	5249.04	5250		
	149	5745	27.85			5732.08	5725
	157	5785	28.34				
	165	5825	27.93				
802.11ac (VHT40) Chain0	38	5190	36.13				
	46	5230	36.82	5248.76	5250		
	151	5755	55.11			5729	5725
	159	5795	52.88				

TEST REPORT

Mode	Channel	Frequency (MHz)	99% Bandwidth (MHz)	Upper Frequency (MHz)	Upper Limit (MHz)	Lower Frequency (MHz)	Lower Limit (MHz)
802.11ac (VHT40) Chain1	38	5190	36.08				
	46	5230	36.42	5248.40	5250		
	151	5755	55.41			5730	5725
	159	5795	54.27				
802.11ac (VHT80) Chain0	42	5210	74.56	5247.76	5250		
	155	5775	93.43			5729.24	5725
802.11ac (VHT80) Chain1	42	5210	74.53	5247.60	5250		
	155	5775	95.38			5734.04	5725

Chain0 : 99% Occupied Bandwidth @ 802.11a Mode Ch36

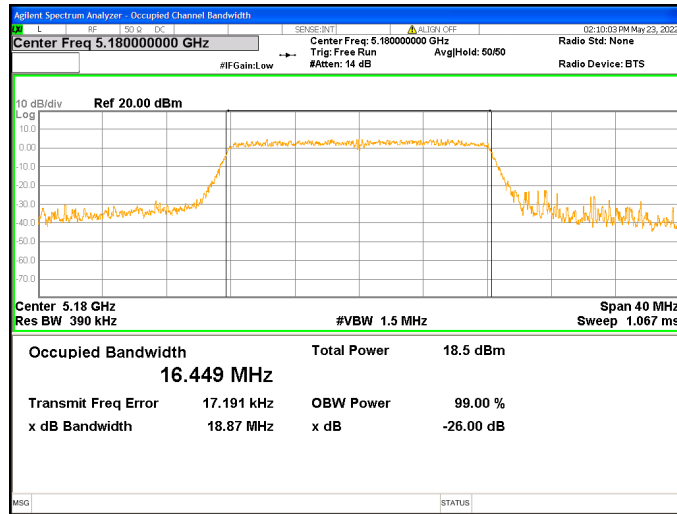

Chain0 : 99% Occupied Bandwidth @ 802.11a Mode Ch44

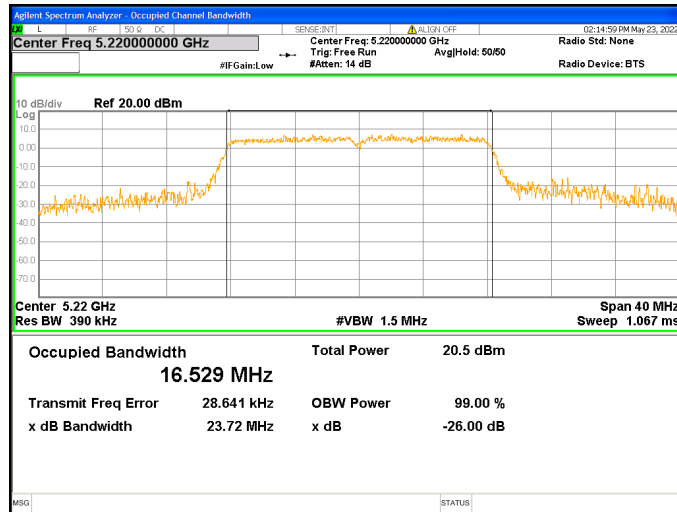

Chain0 : 99% Occupied Bandwidth @ 802.11a Mode Ch48

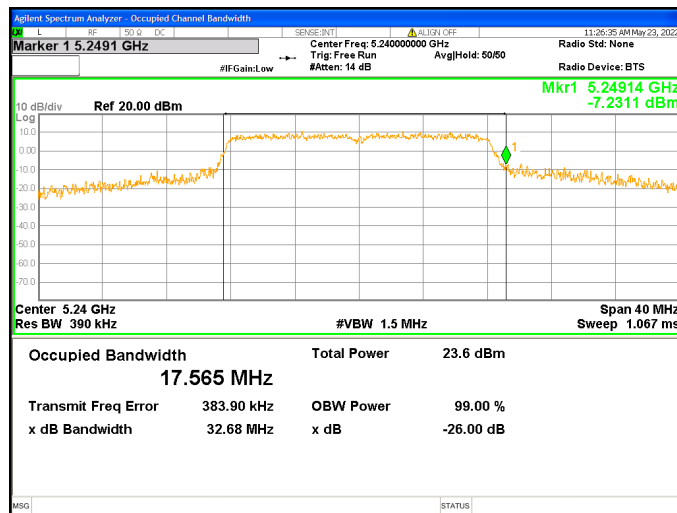

Chain0 : 99% Occupied Bandwidth @ 802.11a Mode Ch149

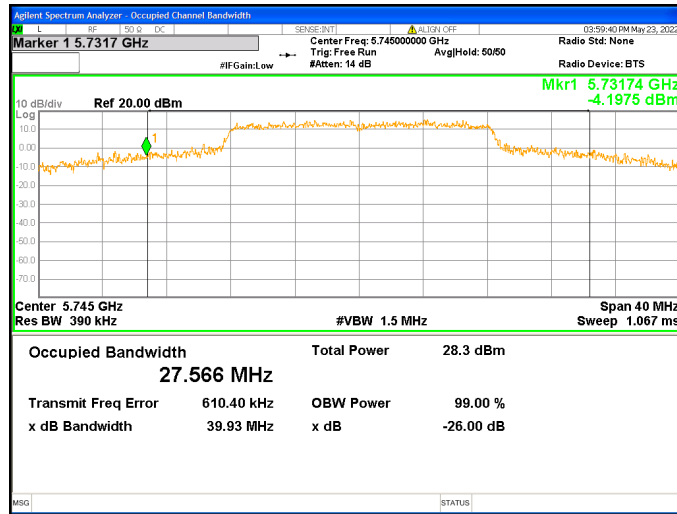

Chain0 : 99% Occupied Bandwidth @ 802.11a Mode Ch157

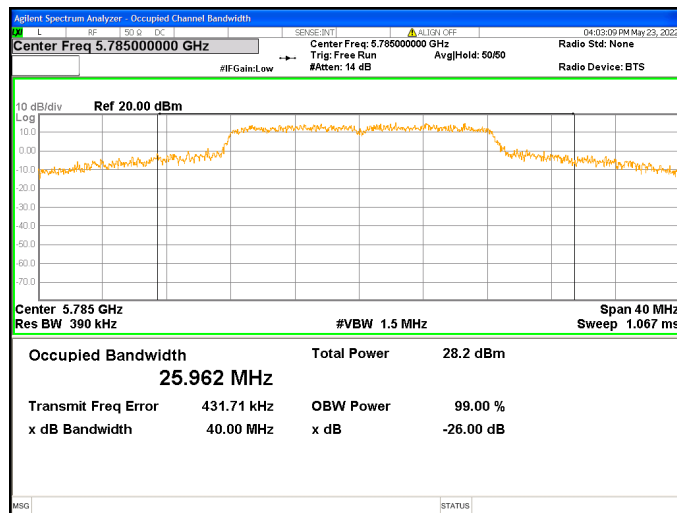

Chain0 : 99% Occupied Bandwidth @ 802.11a Mode Ch165

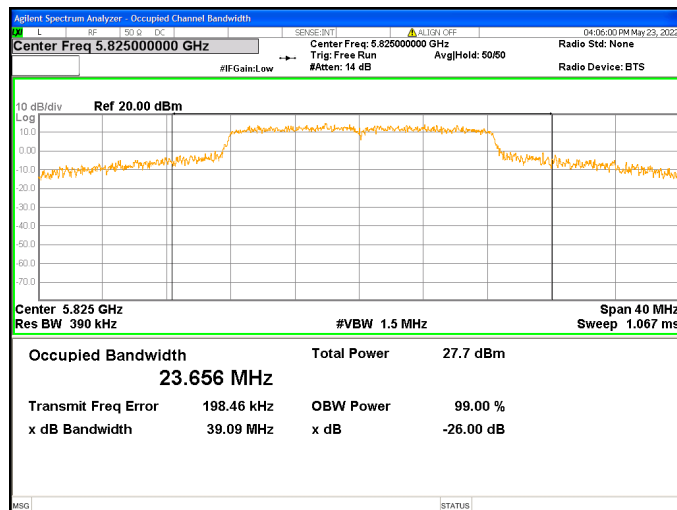

Chain1 : 99% Occupied Bandwidth @ 802.11a Mode Ch36

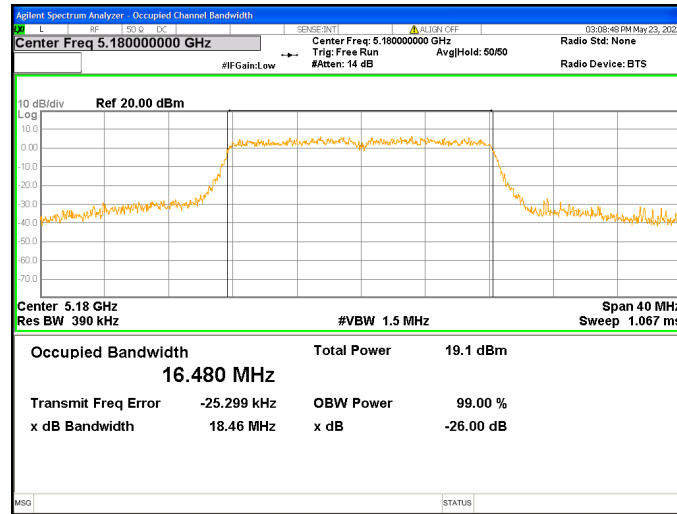

Chain1 : 99% Occupied Bandwidth @ 802.11a Mode Ch44

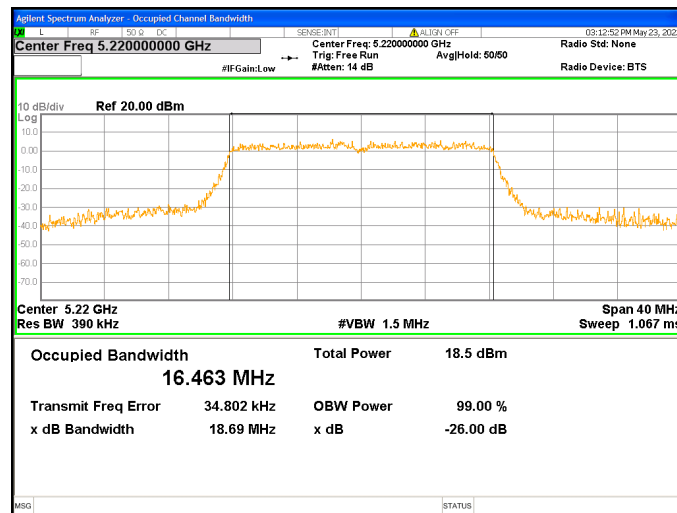

Chain1 : 99% Occupied Bandwidth @ 802.11a Mode Ch48

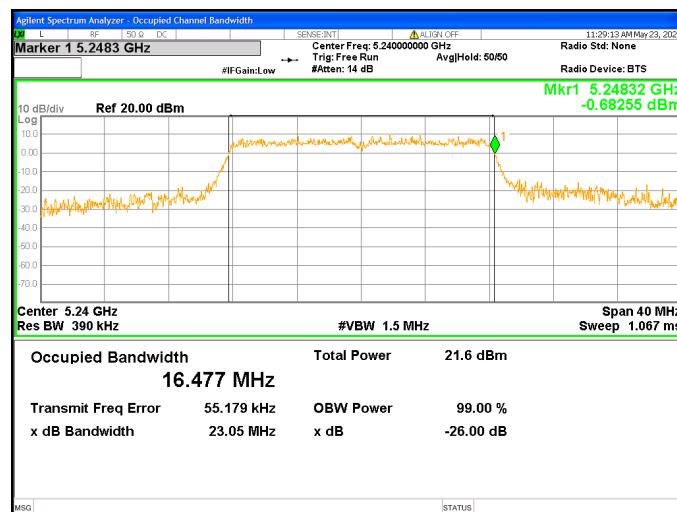

Chain1 : 99% Occupied Bandwidth @ 802.11a Mode Ch149

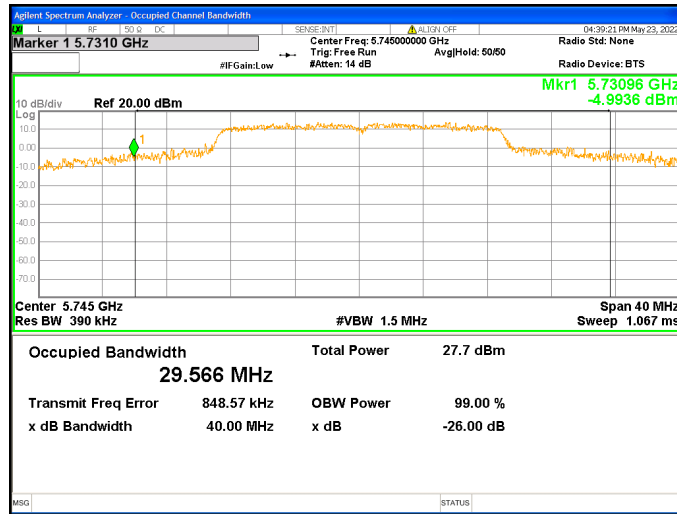

Chain1 : 99% Occupied Bandwidth @ 802.11a Mode Ch157

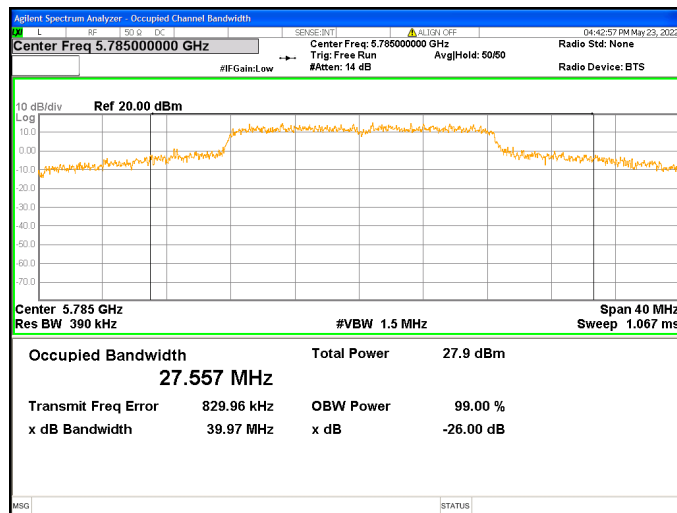

Chain1 : 99% Occupied Bandwidth @ 802.11a Mode Ch165

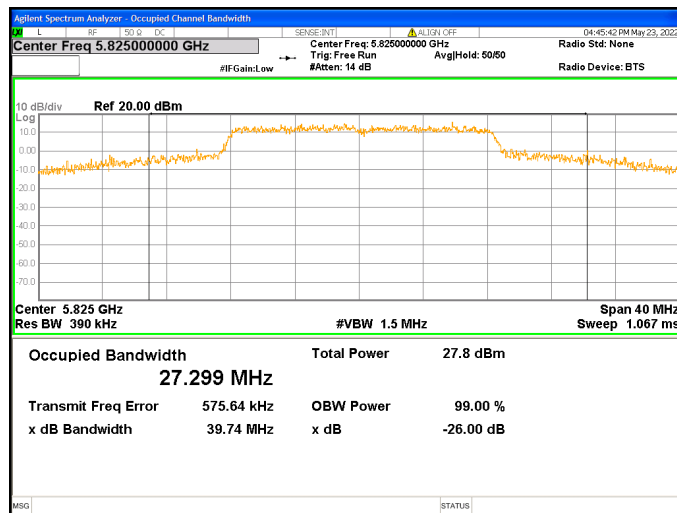

Chain0 : 99% Occupied Bandwidth @ 802.11ac(VHT20) Mode Ch36

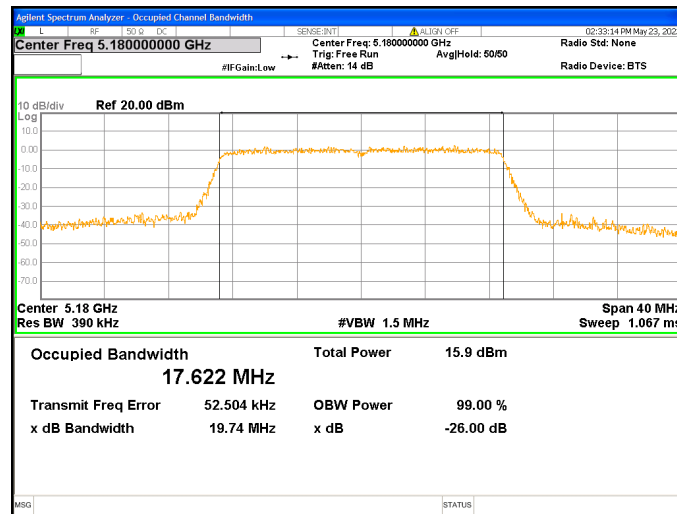

Chain0 : 99% Occupied Bandwidth @ 802.11ac(VHT20) Mode Ch44

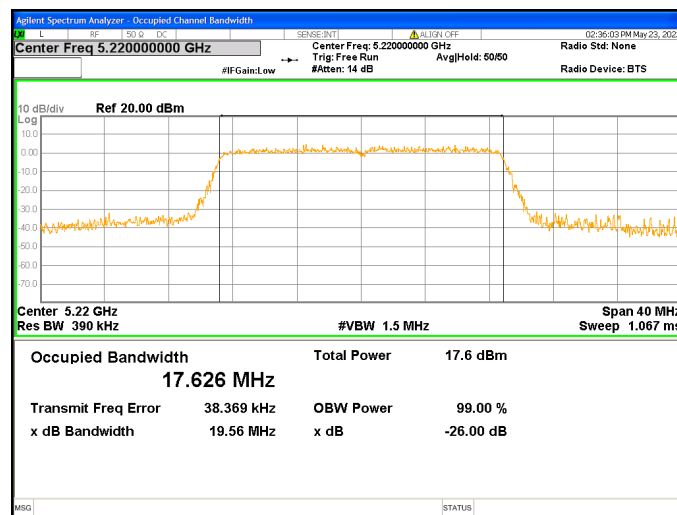

Chain0 : 99% Occupied Bandwidth @ 802.11ac(VHT20) Mode Ch48

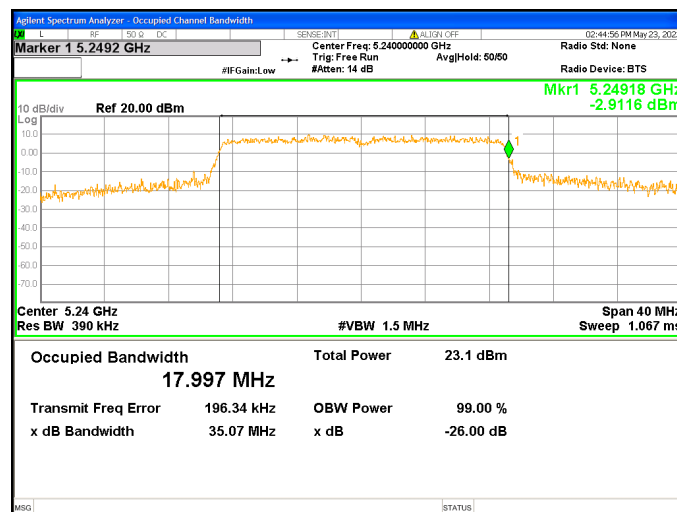

Chain0 : 99% Occupied Bandwidth @ 802.11ac(VHT20) Mode Ch149

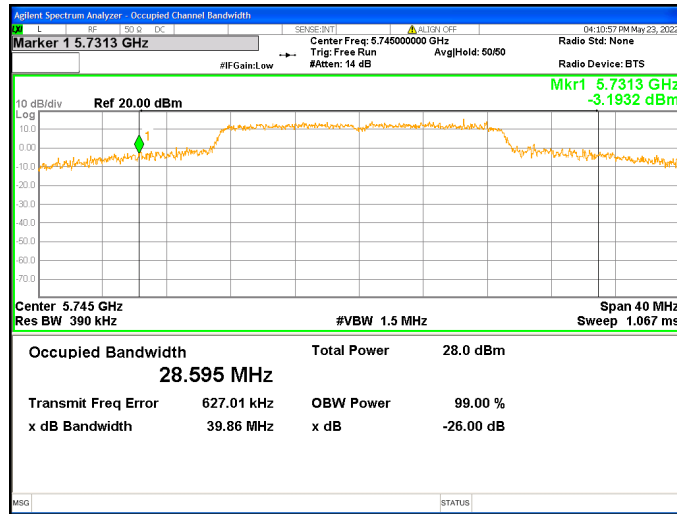

Chain0 : 99% Occupied Bandwidth @ 802.11ac(VHT20) Mode Ch157

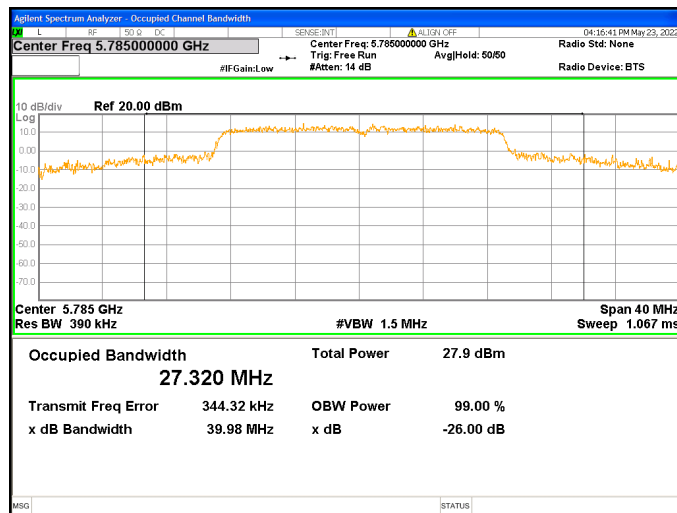

Chain0 : 99% Occupied Bandwidth @ 802.11ac(VHT20) Mode Ch165

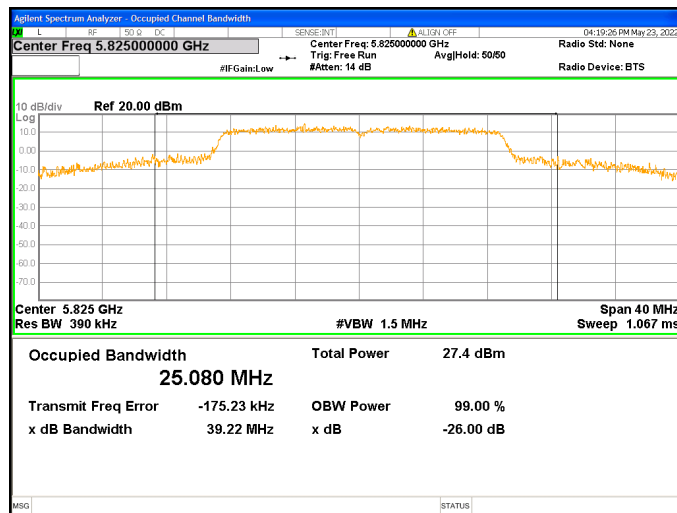

Chain1 : 99% Occupied Bandwidth @ 802.11ac(VHT20) Mode Ch36

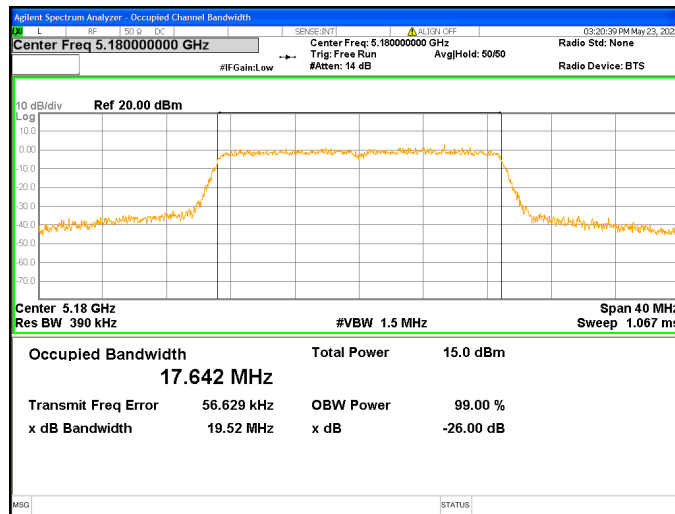

Chain1 : 99% Occupied Bandwidth @ 802.11ac(VHT20) Mode Ch44

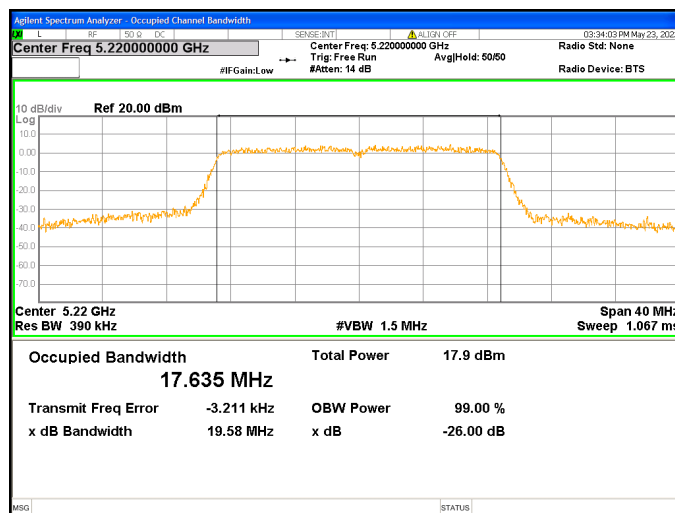

Chain1 : 99% Occupied Bandwidth @ 802.11ac(VHT20) Mode Ch48

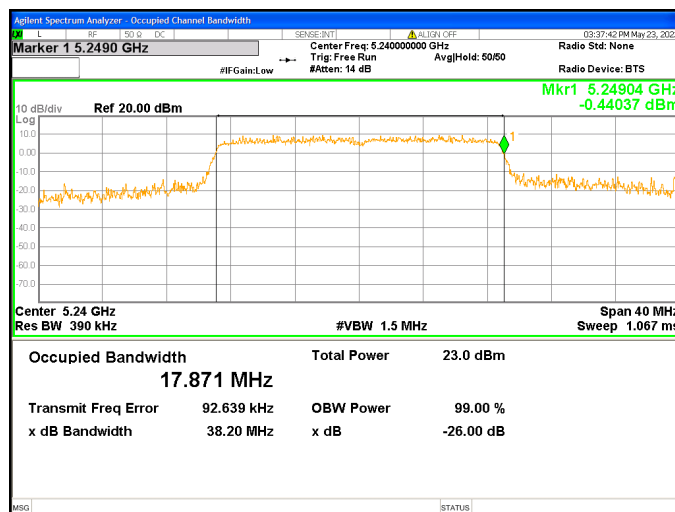

Chain1 : 99% Occupied Bandwidth @ 802.11ac(VHT20) Mode Ch149

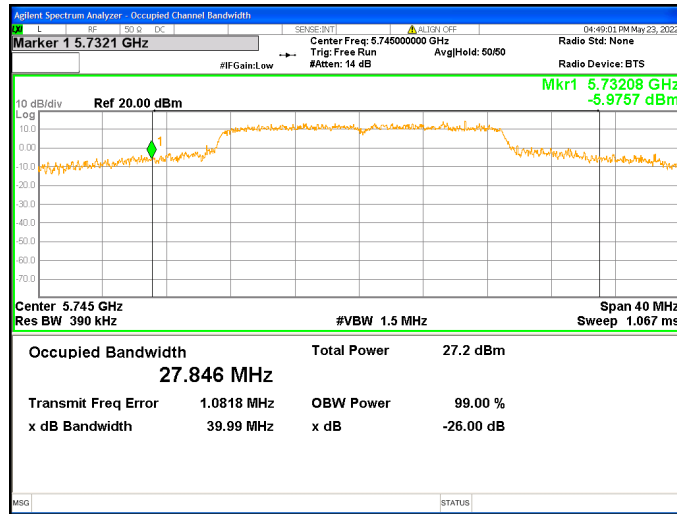

Chain1 : 99% Occupied Bandwidth @ 802.11ac(VHT20) Mode Ch157

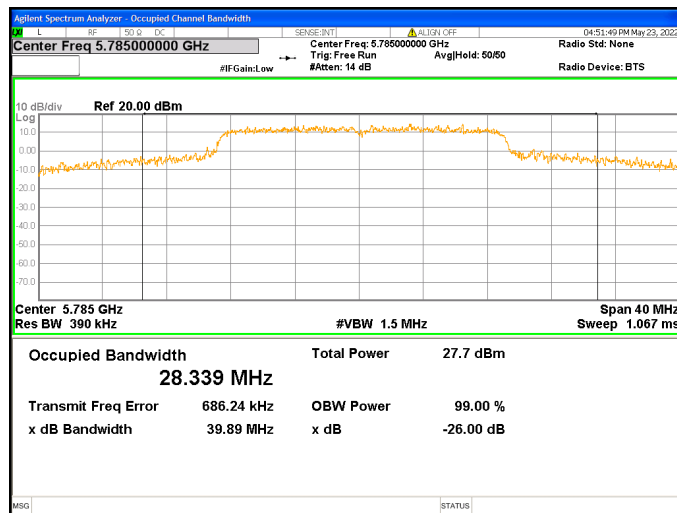

Chain1 : 99% Occupied Bandwidth @ 802.11ac(VHT20) Mode Ch165

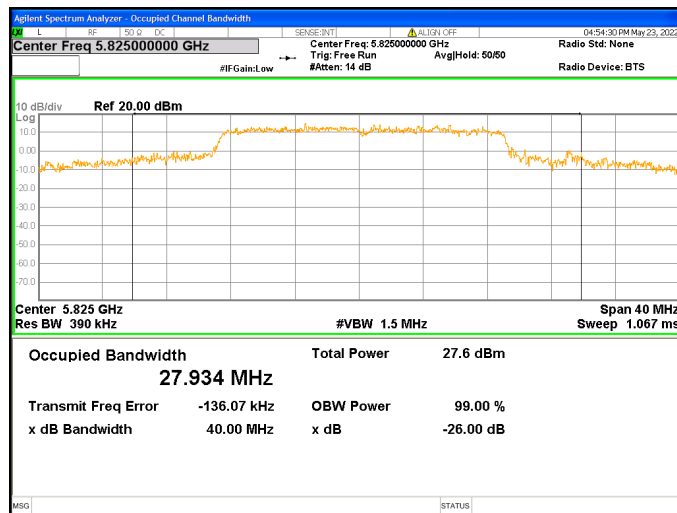

Chain0 : 99% Occupied Bandwidth @ 802.11ac(VHT40) Mode Ch38

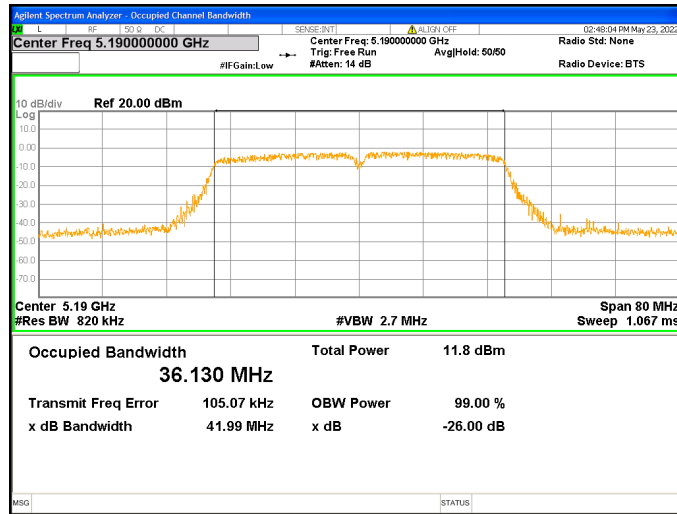

Chain0 : 99% Occupied Bandwidth @ 802.11ac(VHT40) Mode Ch46

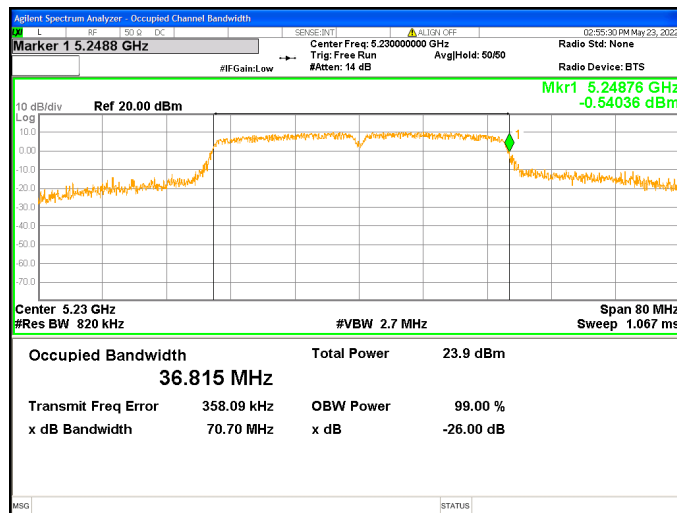

Chain0 : 99% Occupied Bandwidth @ 802.11ac(VHT40) Mode Ch151

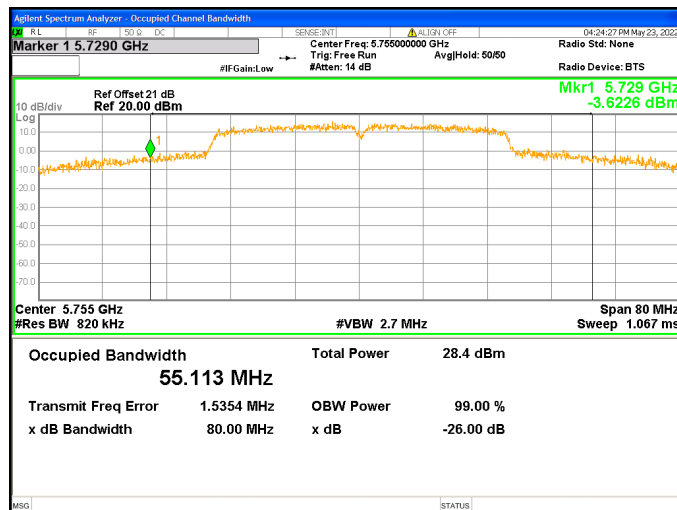

Chain0 : 99% Occupied Bandwidth @ 802.11ac(VHT40) Mode Ch159

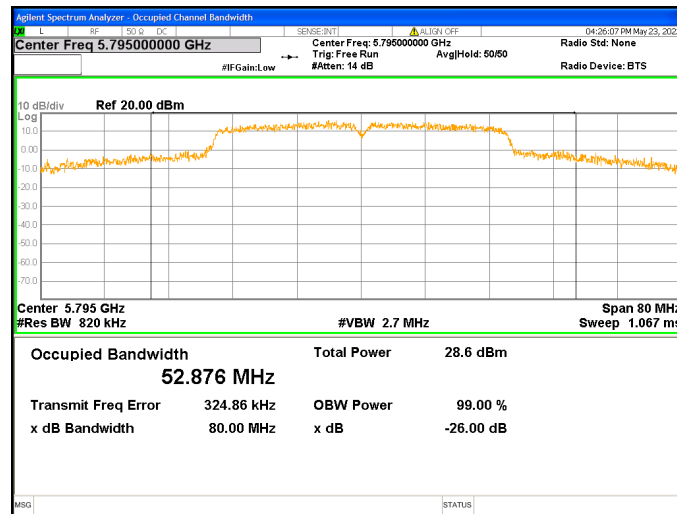

Chain1 : 99% Occupied Bandwidth @ 802.11ac(VHT40) Mode Ch38

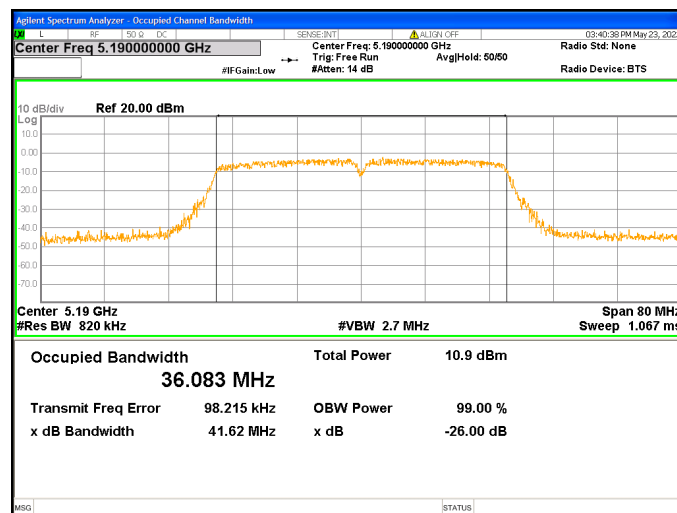

Chain1 : 99% Occupied Bandwidth @ 802.11ac(VHT40) Mode Ch46

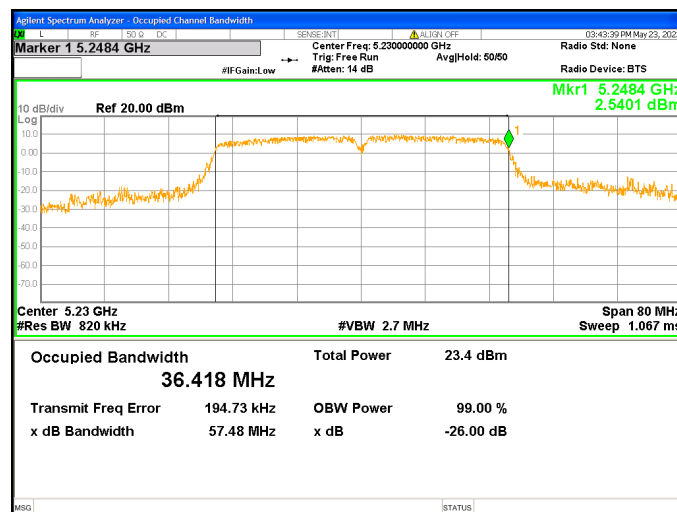

Chain1 : 99% Occupied Bandwidth @ 802.11ac(VHT40) Mode Ch151

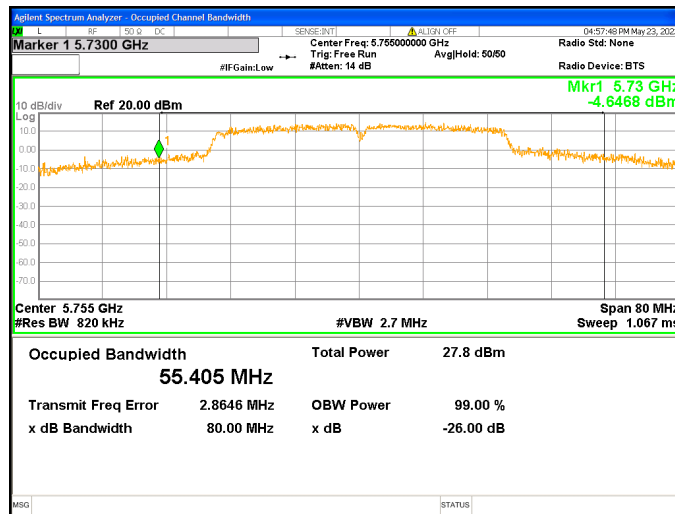

Chain1 : 99% Occupied Bandwidth @ 802.11ac(VHT40) Mode Ch159

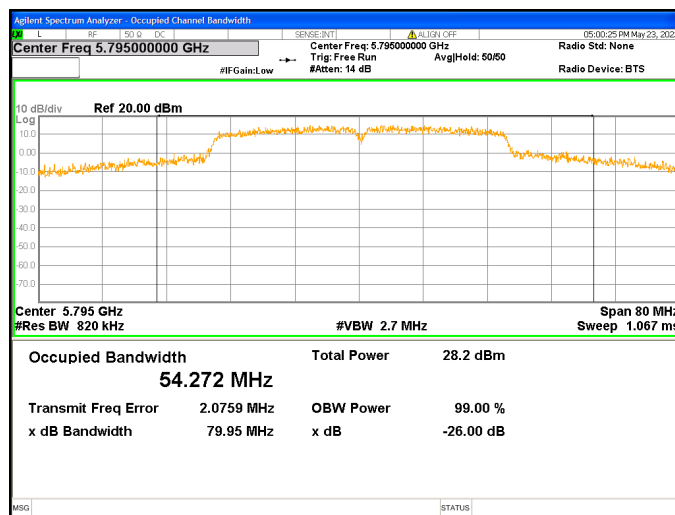

Chain0 : 99% Occupied Bandwidth @ 802.11ac(VHT80) Mode Ch42

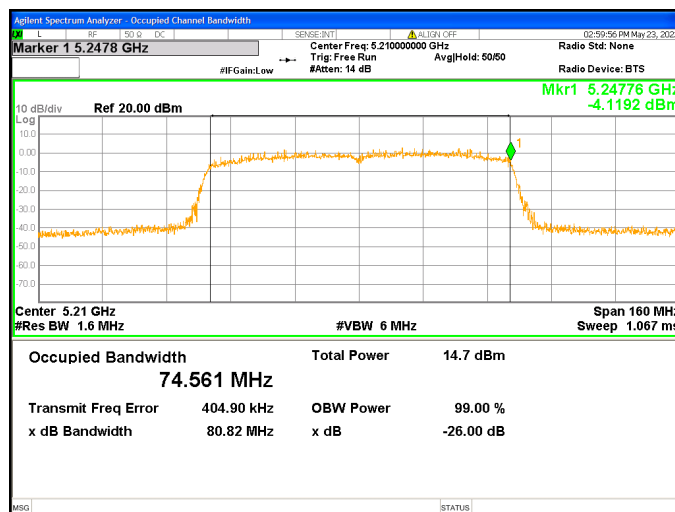

Chain0 : 99% Occupied Bandwidth @ 802.11ac(VHT80) Mode Ch155

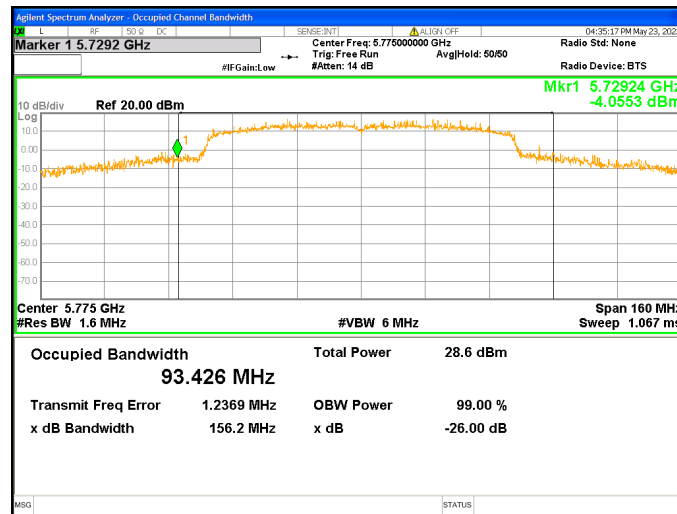

Chain1 : 99% Occupied Bandwidth @ 802.11ac(VHT80) Mode Ch42

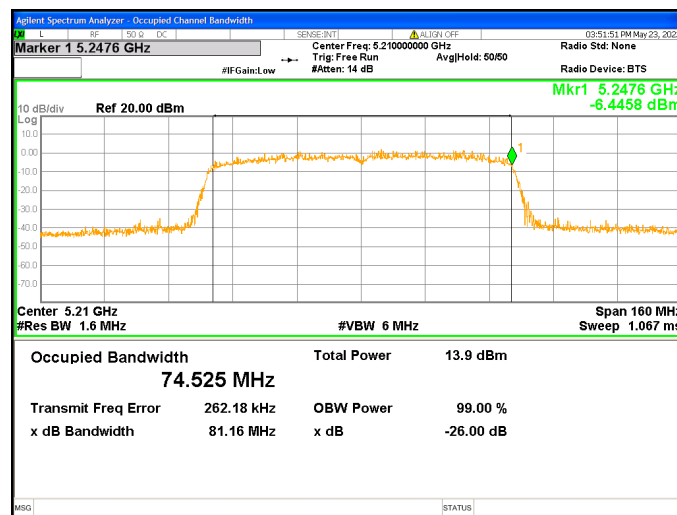

Chain1 : 99% Occupied Bandwidth @ 802.11ac(VHT80) Mode Ch155

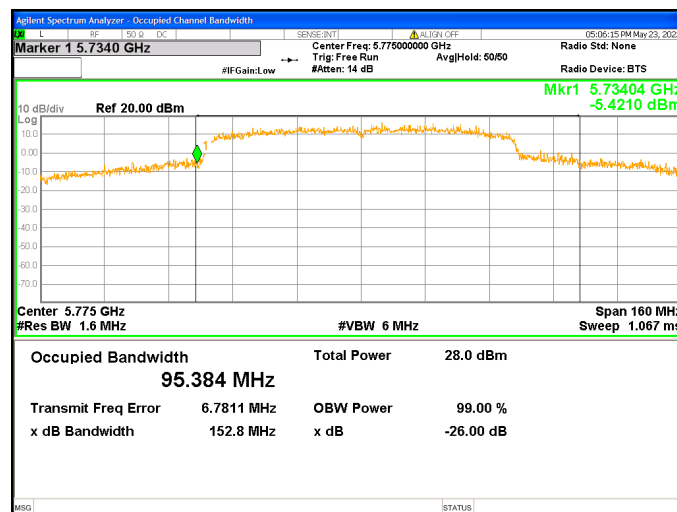

TEST REPORT

5. Emissions in Restricted Frequency Bands (Radiated emission measurements)

5.1 Limit for emission in restricted frequency bands (Radiated emission measurement)

Frequency (MHz)	Field Strength (microvolts/meter)	Measurement distance (meters)
0.009~0.490	2400/F(kHz)	300
0.490~1.705	2400/F(kHz)	30
1.705~30	30	30
30-88	100	3
88-216	150	3
216-960	200	3
Above 960	500	3

Remark:

1. In the above table, the tighter limit applies at the band edges.
2. Distance refers to the distance in meters between the measuring instrument antenna and the closed point of any part of the device or system

As specified in 15.407(b), For transmitters operating in the 5.15-5.25 GHz band: All emissions outside of the 5.15-5.35 GHz band shall not exceed an e.i.r.p. of -27 dBm/MHz.

(2) For transmitters operating in the 5.25-5.35 GHz band: All emissions outside of the 5.15-5.35 GHz band shall not exceed an e.i.r.p. of -27 dBm/MHz.

(3) For transmitters operating in the 5.47-5.725 GHz band: All emissions outside of the 5.47-5.725 GHz band shall not exceed an e.i.r.p. of -27 dBm/MHz.

(4) For transmitters operating in the 5.725-5.85 GHz band:
 All emissions shall be limited to a level of -27 dBm/MHz at 75 MHz or more above or below the band edge increasing linearly to 10 dBm/MHz at 25 MHz above or below the band edge, and from 25 MHz above or below the band edge increasing linearly to a level of 15.6 dBm/MHz at 5 MHz above or below the band edge, and from 5 MHz above or below the band edge increasing linearly to a level of 27 dBm/MHz at the band edge.

However, an out-of-band emission that complies with both the average and peak limits of 15.209 is not required to satisfy the -27 dBm/MHz or -17 dBm/MHz peak emission limit.

5.2 Measuring instrument setting

Below 1GHz measurement

Receiver settings	
Receiver function	Setting
Detector	QP
RBW	9-150 kHz ; 200-300 Hz 0.15-30 MHz; 9-10 kHz 30-1000 MHz; 100-120 kHz
VBW	$\geq 3 \times$ RBW
Sweep	Auto couple
Attenuation	Auto

Above 1GHz measurement

Spectrum analyzer settings	
Spectrum Analyzer function	Setting
Detector	Peak ; Average
RBW	1MHz
VBW	3MHz for Peak; 1/T Minimum kHz for Average
Sweep	Auto couple
Start Frequency	1GHz
Stop Frequency	Tenth harmonic
Attenuation	Auto

TEST REPORT**5.3 Test procedure**

1. Configure the EUT according to ANSI C63.10: 2013 The EUT was placed on the top of the turntable 1.5 meter above ground for above 1GHz and placed on the top of the turntable 0.8 meter above ground for below 1GHz. The center of the receiving antenna mounted on the top of a height-variable antenna tower was placed 3 meters far away from the turntable.
2. Power on the EUT and all the companion devices. The turntable was rotated by 360 degree to find the position of the maximum emission level.
3. The height of the receiving antenna was varied between one meter and four meters above ground to find the maximum emission field strength of the both horizontal and vertical polarization
4. If find the frequencies above the limit or below within 3dB, the antenna tower was scan (from 1m to 4m) and then the turntable was rotated to find the maximum reading.
5. Set the test-receiver system to peak or CISPR quasi-peak detector with specified bandwidth under maximum hold mode.
6. For emissions above 1GHz, use 1MHz VBW and 3MHz RBW for peak reading. Then 1MHz RBW and 10Hz VBW for average reading in spectrum analyzer.
Place the measurement antenna away from each area of the EUT determined to be a source of emissions at the specified measurement distance, while keeping the measurement antenna aimed at the source of emissions at each frequency of significant emissions, with polarization oriented for maximum response.
7. If the emissions level of the EUT in peak mode was 3dB lower than the average limit specified then testing will be stopped and peak values of the EUT will be reported. Otherwise, the emissions which do not have 3dB margin will be measured using the quasi-peak method for below 1GHz.
8. For testing above 1GHz, The emissions level of the EUT in peak mode was lower than average limit, then testing will be stopped and peak values of the EUT will be reported, otherwise, the emission will be measured in average mode again and reported.
9. In case the emission is lower than 30MHz, loop antenna has to be used for measurement and the recorded data should be quasi-peak measured by receiver.

5.4 Test configuration

5.4.1 Radiated emission from 9 kHz to 30MHz using Loop Antenna

Radiated emission from 9kHz to 30MHz uses Loop Antenna:

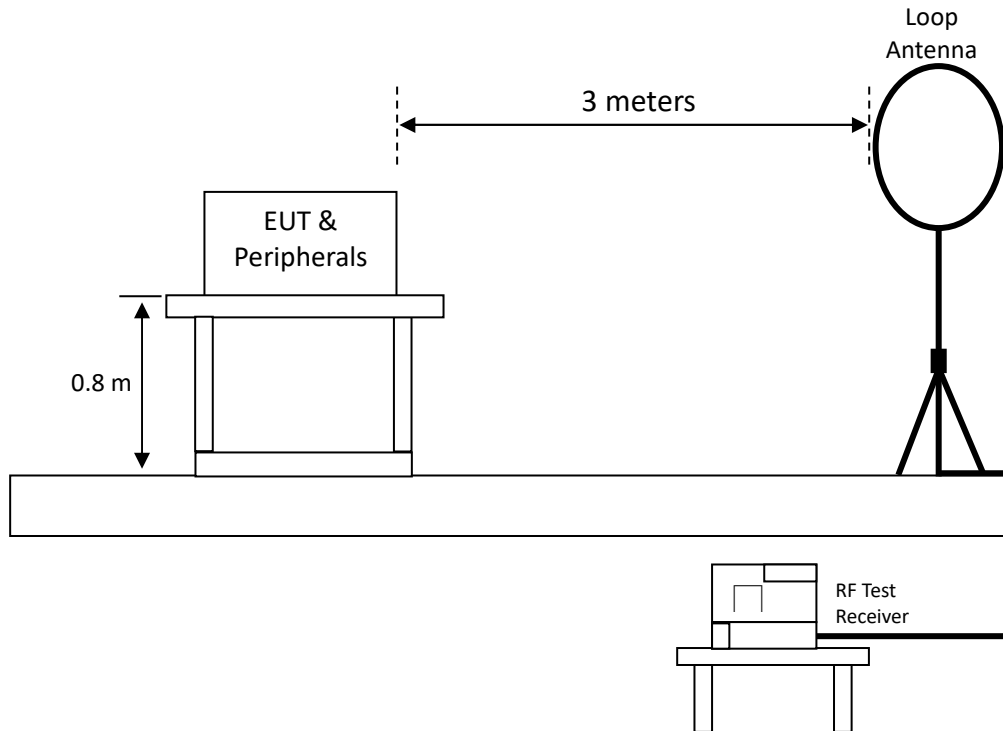

Radiated emission below 1GHz using Bilog Antenna

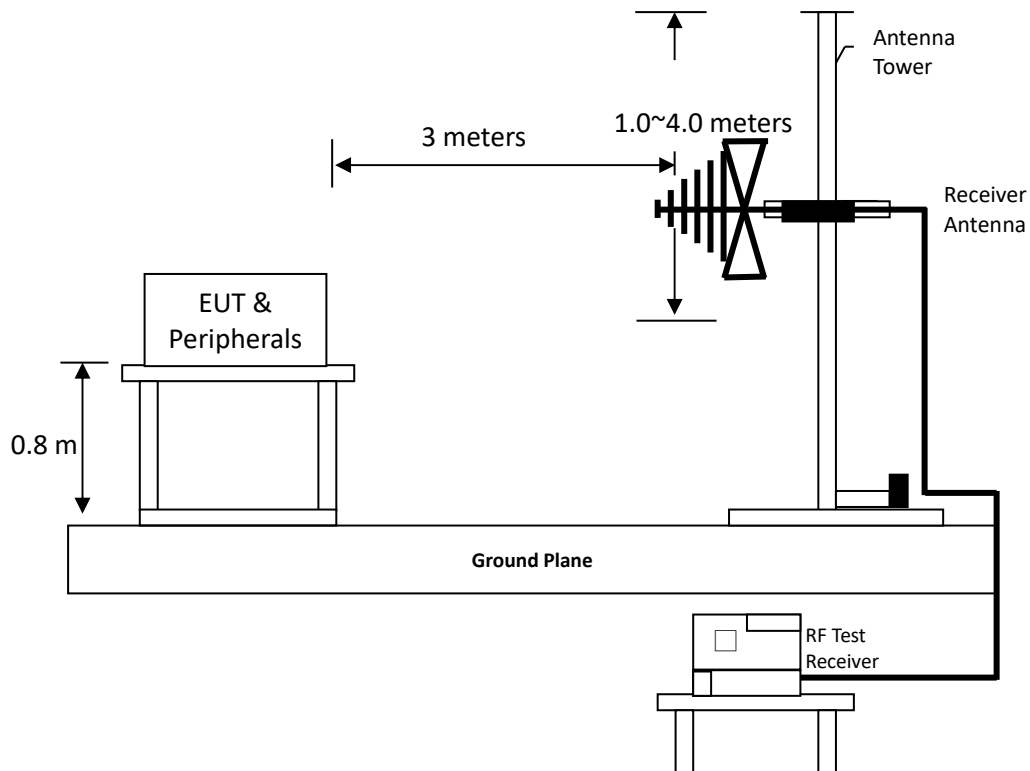

Radiated emission above 1GHz using Horn Antenna

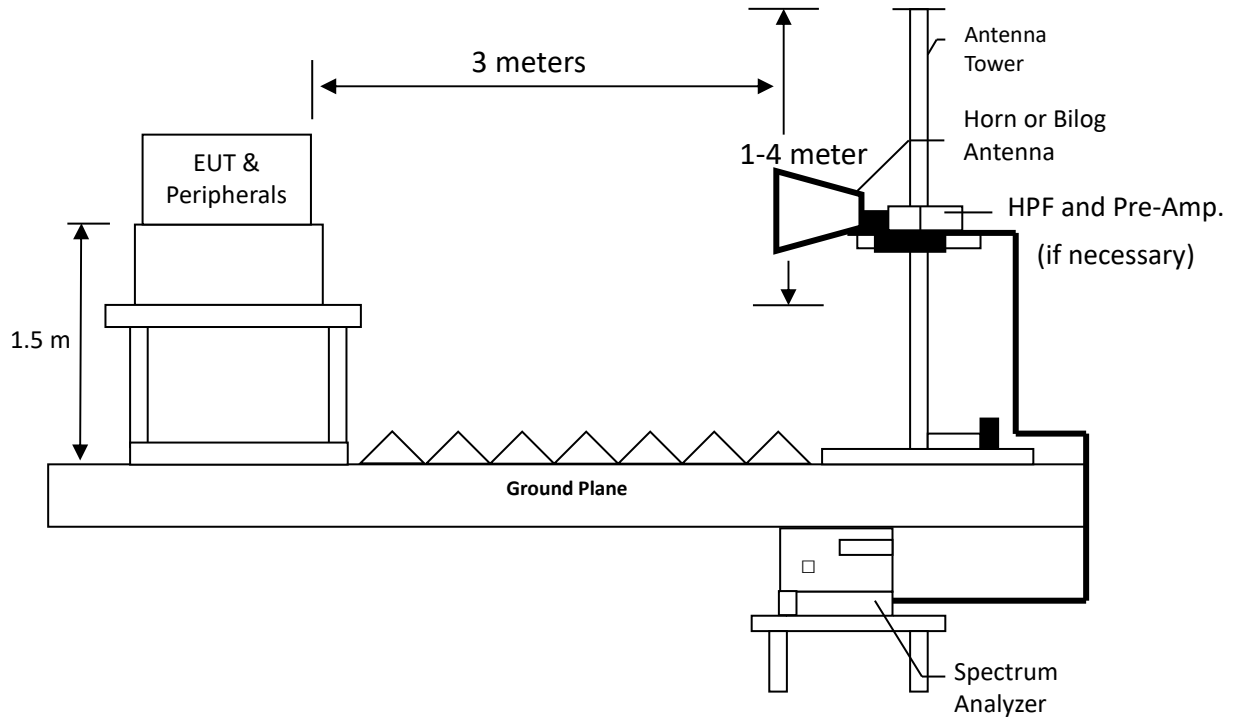

TEST REPORT

5.5 Test results

5.5.1 Measurement results: frequencies from 9 kHz to 30MHz

Temperature (°C) :	25
Relative Humidity (%) :	63
Test date :	2022/05/17
Host 1 :	67401

The test was performed on EUT under 802.11a/an continuously transmitting mode. The worst case occurred at 802.11ac(VHT20) Chain0 Channel 48.

Antenna Polarity	Frequency (MHz)	Spectrum Analyzer Detector	Correction Factor (dB/m)	Reading (dBμV)	Corrected Reading (dBμV/m)	Limit @ 3 m (dBμV/m)	Margin (dB)
Perpendicular	0.129	AV	18.04	50.61	68.65	105.56	-36.91
Perpendicular	0.249	AV	18.45	44.24	62.69	99.69	-37.00
Perpendicular	0.369	AV	18.68	40.34	59.02	96.28	-37.26
Perpendicular	0.549	QP	18.83	30.90	49.73	72.86	-23.13
Perpendicular	0.759	QP	18.95	29.09	48.04	70.06	-22.02
Perpendicular	0.999	QP	19.10	21.32	40.42	67.61	-27.19

Antenna Polarity	Frequency (MHz)	Spectrum Analyzer Detector	Correction Factor (dB/m)	Reading (dBμV)	Corrected Reading (dBμV/m)	Limit @ 3 m (dBμV/m)	Margin (dB)
Parallel	0.069	AV	18.76	52.67	71.43	114.73	-43.30
Parallel	0.189	AV	18.24	46.31	64.55	102.13	-37.58
Parallel	0.429	AV	18.74	40.94	59.68	94.97	-35.29
Parallel	0.549	QP	18.83	31.61	50.44	72.86	-22.42
Parallel	0.819	QP	18.99	26.97	45.96	69.36	-23.40
Parallel	0.879	QP	19.03	24.31	43.34	68.78	-25.44

TEST REPORT

Antenna Polarity	Frequency (MHz)	Spectrum Analyzer Detector	Correction Factor (dB/m)	Reading (dB μ V)	Corrected Reading (dB μ V/m)	Limit @ 3 m (dB μ V/m)	Margin (dB)
Ground-parallel	0.099	QP	17.97	50.29	68.26	107.84	-39.58
Ground-parallel	0.189	AV	18.24	44.47	62.71	102.13	-39.42
Ground-parallel	0.369	AV	18.68	40.72	59.40	96.28	-36.88
Ground-parallel	0.489	AV	18.79	33.87	52.66	93.82	-41.16
Ground-parallel	0.579	QP	18.85	27.79	46.64	72.38	-25.74
Ground-parallel	0.819	QP	18.99	29.48	48.47	69.36	-20.89

TEST REPORT

Temperature (°C) :	25
Relative Humidity (%) :	64
Test date :	2022/05/31
Host 2 :	67301

The test was performed on EUT under 802.11a/an continuously transmitting mode. The worst case occurred at 802.11ac(VHT20) Chain0 Channel 48.

Antenna Polarity	Frequency (MHz)	Spectrum Analyzer Detector	Correction Factor (dB/m)	Reading (dBμV)	Corrected Reading (dBμV/m)	Limit @ 3 m (dBμV/m)	Margin (dB)
Perpendicular	0.159	AV	18.14	54.08	72.22	103.63	-31.41
Perpendicular	0.279	AV	18.55	48.97	67.52	98.73	-31.21
Perpendicular	0.309	AV	18.63	44.73	63.36	97.82	-34.46
Perpendicular	0.489	AV	18.79	36.92	55.71	93.82	-38.11
Perpendicular	0.579	QP	18.85	30.98	49.83	72.38	-22.55
Perpendicular	0.789	QP	18.98	24.17	43.15	69.68	-26.53

Antenna Polarity	Frequency (MHz)	Spectrum Analyzer Detector	Correction Factor (dB/m)	Reading (dBμV)	Corrected Reading (dBμV/m)	Limit @ 3 m (dBμV/m)	Margin (dB)
Parallel	0.099	QP	17.97	52.41	70.38	107.84	-37.46
Parallel	0.279	AV	18.55	46.97	65.52	98.73	-33.21
Parallel	0.459	AV	18.76	36.79	55.55	94.38	-38.83
Parallel	0.609	QP	18.86	28.24	47.10	71.93	-24.83
Parallel	0.819	QP	18.99	22.99	41.98	69.36	-27.38
Parallel	0.909	QP	19.04	17.30	36.34	68.49	-32.15

TEST REPORT

Antenna Polarity	Frequency (MHz)	Spectrum Analyzer Detector	Correction Factor (dB/m)	Reading (dB μ V)	Corrected Reading (dB μ V/m)	Limit @ 3 m (dB μ V/m)	Margin (dB)
Ground-parallel	0.159	AV	18.14	51.08	69.22	103.63	-34.41
Ground-parallel	0.279	AV	18.55	45.97	64.52	98.73	-34.21
Ground-parallel	0.399	AV	18.71	41.52	60.23	95.59	-35.36
Ground-parallel	0.459	AV	18.76	37.79	56.55	94.38	-37.83
Ground-parallel	0.519	QP	18.81	31.56	50.37	73.34	-22.97
Ground-parallel	0.789	QP	18.98	24.17	43.15	69.68	-26.53

TEST REPORT

5.5.2 Measurement results from 30 MHz to 1GHz

Temperature (°C) :	25
Relative Humidity (%) :	63
Test date :	2022/05/17
Host 1 :	67401

The test was performed on EUT under 802.11a/an continuously transmitting mode. The worst case occurred at 802.11ac(VHT20) Chain0 Channel 48.

Antenna Polarity	Frequency (MHz)	Spectrum Analyzer Detector	Correction Factor (dB/m)	Reading (dBμV)	Corrected Reading (dBμV/m)	Limit @ 3 m (dBμV/m)	Margin (dB)
Vertical	43.58	QP	20.22	10.17	30.39	40.00	-9.61
Vertical	110.51	QP	17.03	12.55	29.58	43.50	-13.92
Vertical	134.76	QP	19.36	11.54	30.90	43.50	-12.60
Vertical	159.01	QP	20.69	14.78	35.47	43.50	-8.03
Vertical	331.67	QP	22.58	12.04	34.62	46.00	-11.38
Vertical	381.14	QP	23.87	10.00	33.87	46.00	-12.13

Antenna Polarity	Frequency (MHz)	Spectrum Analyzer Detector	Correction Factor (dB/m)	Reading (dBμV)	Corrected Reading (dBμV/m)	Limit @ 3 m (dBμV/m)	Margin (dB)
Horizontal	110.51	QP	17.03	17.51	34.54	43.50	-8.96
Horizontal	159.01	QP	20.69	17.81	38.50	43.50	-5.00
Horizontal	208.48	QP	17.62	12.98	30.60	43.50	-12.90
Horizontal	307.42	QP	21.86	12.69	34.55	46.00	-11.45
Horizontal	331.67	QP	22.58	14.84	37.42	46.00	-8.58
Horizontal	752.65	QP	31.56	8.61	40.17	46.00	-5.83

Remark: Corr. Factor = Antenna Factor + Cable Loss

TEST REPORT

Temperature (°C) :	25
Relative Humidity (%) :	64
Test date :	2022/05/31
Host 2 :	67301

The test was performed on EUT under 802.11a/an continuously transmitting mode. The worst case occurred at 802.11ac(VHT20) Chain0 Channel 48.

Antenna Polarity	Frequency (MHz)	Spectrum Analyzer Detector	Correction Factor (dB/m)	Reading (dBμV)	Corrected Reading (dBμV/m)	Limit @ 3 m (dBμV/m)	Margin (dB)
Vertical	275.41	QP	20.95	15.75	36.70	46.00	-9.30
Vertical	376.29	QP	23.76	14.35	38.11	46.00	-7.89
Vertical	395.69	QP	24.20	14.24	38.44	46.00	-7.56
Vertical	450.98	QP	25.87	13.99	39.86	46.00	-6.14
Vertical	564.47	QP	27.87	10.14	38.01	46.00	-7.99
Vertical	713.85	QP	30.36	13.16	43.52	46.00	-2.48

Antenna Polarity	Frequency (MHz)	Spectrum Analyzer Detector	Correction Factor (dB/m)	Reading (dBμV)	Corrected Reading (dBμV/m)	Limit @ 3 m (dBμV/m)	Margin (dB)
Horizontal	252.13	QP	19.92	14.44	34.36	46.00	-11.64
Horizontal	275.41	QP	20.95	11.90	32.85	46.00	-13.15
Horizontal	450.98	QP	25.87	8.32	34.19	46.00	-11.81
Horizontal	564.47	QP	27.87	11.81	39.68	46.00	-6.32
Horizontal	708.03	QP	30.34	5.46	35.80	46.00	-10.20
Horizontal	804.06	QP	32.09	4.97	37.06	46.00	-8.94

Remark: Corr. Factor = Antenna Factor + Cable Loss

TEST REPORT

5.5.3 Measurement results from 1 GHz to 40 GHz

Temperature (°C) :	25
Relative Humidity (%) :	63
Test date :	2022/05/21
Host 1 :	67401

Mode	Frequency (MHz)	Spectrum Analyzer Detector	Ant. Pol. (H/V)	Correction Factor (dB/m)	Reading (dBµV)	Corrected Reading (dBµV/m)	Limit @ 3 m (dBµV/m)	Margin (dB)
802.11a_Ch36	10360	PK	H	8.98	38.08	47.06	74	-26.94
	10360	PK	V	8.98	38.05	47.03	74	-26.97
802.11a_Ch44	10440	PK	H	9.60	36.71	46.31	74	-27.69
	10440	PK	V	9.60	37.79	47.39	74	-26.61
802.11a_Ch48	10480	PK	H	9.80	41.43	51.23	74	-22.77
	10480	PK	V	9.80	37.68	47.48	74	-26.52
802.11a_Ch149	11490	PK	H	12.47	38.03	50.50	74	-23.50
	11490	PK	V	12.47	38.58	51.05	74	-22.95
802.11a_Ch157	11570	PK	H	12.41	38.98	51.39	74	-22.61
	11570	PK	V	12.41	37.84	50.25	74	-23.75
802.11a_Ch165	11650	PK	H	12.24	38.69	50.93	74	-23.07
	11650	PK	V	12.24	37.93	50.17	74	-23.83
802.11ac(VHT20)_Ch36	10360	PK	H	8.98	39.17	48.15	74	-25.85
	10360	PK	V	8.98	38.45	47.43	74	-26.57
802.11ac(VHT20)_Ch44	10440	PK	H	9.62	36.88	46.50	74	-27.50
	10440	PK	V	9.60	36.62	46.22	74	-27.78
802.11ac(VHT20)_Ch48	10480	PK	H	9.80	39.84	49.64	74	-24.36
	10480	PK	V	9.80	39.51	49.31	74	-24.69
802.11ac(VHT20)_Ch149	11490	PK	H	12.47	38.42	50.89	74	-23.11
	11490	PK	V	12.47	38.65	51.12	74	-22.88
802.11ac(VHT20)_Ch157	11570	PK	H	12.41	37.78	50.19	74	-23.81
	11570	PK	V	12.41	37.67	50.08	74	-23.92
802.11ac(VHT20)_Ch165	11650	PK	H	12.24	38.28	50.52	74	-23.48
	11650	PK	V	12.24	38.65	50.89	74	-23.11
802.11ac(VHT40)_Ch38	10380	PK	H	9.19	40.16	49.35	74	-24.65
	10380	PK	V	9.19	39.69	48.88	74	-25.12
802.11ac(VHT40)_Ch46	10460	PK	H	9.70	40.37	50.07	74	-23.93
	10460	PK	V	9.70	39.86	49.56	74	-24.44
802.11ac(VHT40)_Ch151	11510	PK	H	12.51	37.49	50.00	74	-24.00
	11510	PK	V	12.51	37.78	50.29	74	-23.71

TEST REPORT

Mode	Frequency (MHz)	Spectrum Analyzer Detector	Ant. Pol. (H/V)	Correction Factor (dB/m)	Reading (dBμV)	Corrected Reading (dBμV/m)	Limit @ 3 m (dBμV/m)	Margin (dB)
802.11ac(VHT40)_Ch159	11590	PK	H	12.38	37.62	50.00	74	-24.00
	11590	PK	V	12.38	38.26	50.64	74	-23.36
802.11ac(VHT80)_Ch42	10420	PK	H	9.50	40.37	49.87	74	-24.13
	10420	PK	V	9.50	41.34	50.84	74	-23.16
802.11ac(VHT80)_Ch155	11550	PK	H	12.45	37.96	50.41	74	-23.59
	11550	PK	V	12.45	36.62	49.07	74	-24.93

Remark: Correction Factor = Antenna Factor + Cable Loss + High Pass Filter Loss - Pre_Amplifier Gain

TEST REPORT

Temperature (°C) :	25
Relative Humidity (%) :	64
Test date :	2022/05/31
Host 2 :	67301

Mode	Frequency (MHz)	Spectrum Analyzer Detector	Ant. Pol. (H/V)	Correction Factor (dB/m)	Reading (dBμV)	Corrected Reading (dBμV/m)	Limit @ 3 m (dBμV/m)	Margin (dB)
802.11a_Ch36	10360	PK	H	8.43	41.17	49.60	74	-24.40
	10360	PK	V	8.43	40.75	49.18	74	-24.82
802.11a_Ch44	10440	PK	H	8.99	41.39	50.38	74	-23.62
	10440	PK	V	8.99	41.36	50.35	74	-23.65
802.11a_Ch48	10480	PK	H	9.17	40.68	49.85	74	-24.15
	10480	PK	V	9.17	41.45	50.62	74	-23.38
802.11a_Ch149	11490	PK	H	11.32	39.70	51.02	74	-22.98
	11490	PK	V	11.32	39.91	51.23	74	-22.77
802.11a_Ch157	11570	PK	H	11.25	39.24	50.49	74	-23.51
	11570	PK	V	11.25	39.74	50.99	74	-23.01
802.11a_Ch165	11650	PK	H	11.10	39.32	50.42	74	-23.58
	11650	PK	V	11.10	40.16	51.26	74	-22.74
802.11ac(VHT20)_Ch36	10360	PK	H	8.43	41.61	50.04	74	-23.96
	10360	PK	V	8.43	42.34	50.77	74	-23.23
802.11ac(VHT20)_Ch44	10440	PK	H	8.99	41.30	50.29	74	-23.71
	10440	PK	V	8.99	40.90	49.89	74	-24.11
802.11ac(VHT20)_Ch48	10480	PK	H	9.17	41.08	50.25	74	-23.75
	10480	PK	V	9.17	40.69	49.86	74	-24.14
802.11ac(VHT20)_Ch149	11490	PK	H	11.32	40.25	51.57	74	-22.43
	11490	PK	V	11.32	39.25	50.57	74	-23.43
802.11ac(VHT20)_Ch157	11570	PK	H	11.25	40.08	51.33	74	-22.67
	11570	PK	V	11.25	39.48	50.73	74	-23.27
802.11ac(VHT20)_Ch165	11650	PK	H	11.10	39.63	50.73	74	-23.27
	11650	PK	V	11.10	39.90	51.00	74	-23.00
802.11ac(VHT40)_Ch38	10380	PK	H	8.62	41.32	49.94	74	-24.06
	10380	PK	V	8.62	42.77	51.39	74	-22.61
802.11ac(VHT40)_Ch46	10460	PK	H	9.08	42.56	51.64	74	-22.36
	10460	PK	V	9.08	41.40	50.48	74	-23.52
802.11ac(VHT40)_Ch151	11510	PK	H	11.34	39.60	50.94	74	-23.06
	11510	PK	V	11.34	40.70	52.04	74	-21.96

TEST REPORT

Mode	Frequency (MHz)	Spectrum Analyzer Detector	Ant. Pol. (H/V)	Correction Factor (dB/m)	Reading (dBμV)	Corrected Reading (dBμV/m)	Limit @ 3 m (dBμV/m)	Margin (dB)
802.11ac(VHT40)_Ch159	11590	PK	H	11.22	39.87	51.09	74	-22.91
	11590	PK	V	11.22	39.47	50.69	74	-23.31
802.11ac(VHT80)_Ch42	10420	PK	H	8.90	40.79	49.69	74	-24.31
	10420	PK	V	8.90	42.03	50.93	74	-23.07
802.11ac(VHT80)_Ch155	11550	PK	H	11.29	39.64	50.93	74	-23.07
	11550	PK	V	11.29	39.53	50.82	74	-23.18

Remark: Correction Factor = Antenna Factor + Cable Loss + High Pass Filter Loss - Pre_Amplifier Gain

6. Emission on The Band Edge

6.1 Measuring instrument setting

For 5.15 GHz -5.25 GHz

Spectrum analyzer settings	
Spectrum Analyzer function	Setting
Detector	Peak ; Average
RBW	1MHz
VBW	3MHz for Peak; 1/T Minimum kHz for Average
Sweep	Auto couple
Restrict bands	4500~5150MHz
	5350 ~5460MHz
Attenuation	Auto

For 5.725 GHz -5.850 GHz

Spectrum analyzer settings	
Spectrum Analyzer function	Setting
Detector	Peak
RBW	1MHz
VBW	3MHz
Sweep	Auto couple
Attenuation	Auto

6.2 Test procedure

The test procedure is the same as clause 5.3

6.3 Limit for Band Edge (Radiated emission measurement)

Refer to clause 5.1

6.4 Test Result

Temperature (°C) :	27
Relative Humidity (%) :	60
Test date :	2022/05/20
Host 1 :	67401

Mode	Frequency (MHz)	Spectrum Analyzer Detector	Ant. Pol. (H/V)	Correction Factor (dB/m)	Reading (dBμV)	Corrected Reading (dBμV/m)	Limit @ 3 m (dBμV/m)	Margin (dB)	Restricted band (MHz)
802.11a	5150.00	PK	H	-5.75	73.91	68.16	74	-5.84	4500~5150
	5150.00	AV	H	-5.75	59.38	53.63	54	-0.37	
	5414.88	PK	H	-5.26	64.41	59.15	74	-14.85	5350~5460
	5444.64	AV	H	-5.04	54.09	49.05	54	-4.95	
802.11ac(VHT20)	5150.00	PK	H	-5.75	70.70	64.95	74	-9.05	4500~5150
	5150.00	AV	H	-5.75	59.08	53.33	54	-0.67	
	5356.32	PK	H	-5.59	65.03	59.44	74	-14.56	5350~5460
	5444.64	AV	H	-5.04	53.98	48.94	54	-5.06	
802.11ac(VHT40)	5150.00	PK	H	-5.75	72.34	66.59	74	-7.41	4500~5150
	5150.00	AV	H	-5.75	58.69	52.94	54	-1.06	
	5350.00	PK	H	-5.62	70.78	65.16	74	-8.84	5350~5460
	5350.00	AV	H	-5.62	59.16	53.54	54	-0.46	
802.11ac(VHT80)	5150.00	PK	H	-5.75	70.43	64.68	74	-9.32	4500~5150
	5150.00	AV	H	-5.75	58.35	52.60	54	-1.40	
	5423.52	PK	H	-5.20	65.09	59.89	74	-14.11	5350~5460
	5444.64	AV	H	-5.04	54.07	49.03	54	-4.97	

Remark: Correction Factor = Antenna Factor + Cable Loss - Pre_Amplifier Gain

Chain0+1 : Restricted Band Bandedge @ 802.11a Mode Ch36 PK

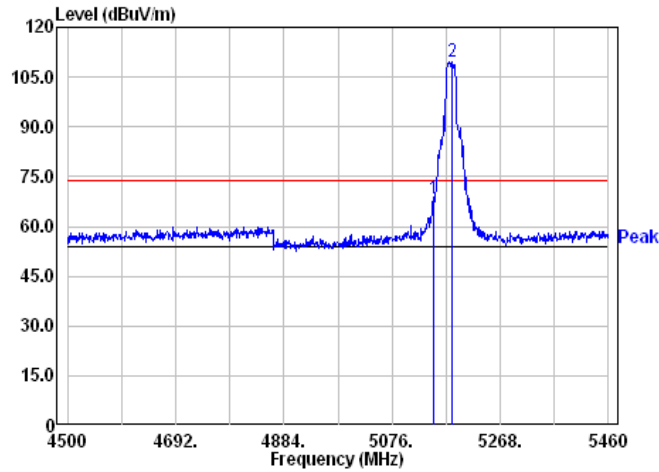

Chain0+1 : Restricted Band Bandedge @ 802.11a Mode Ch36 AV

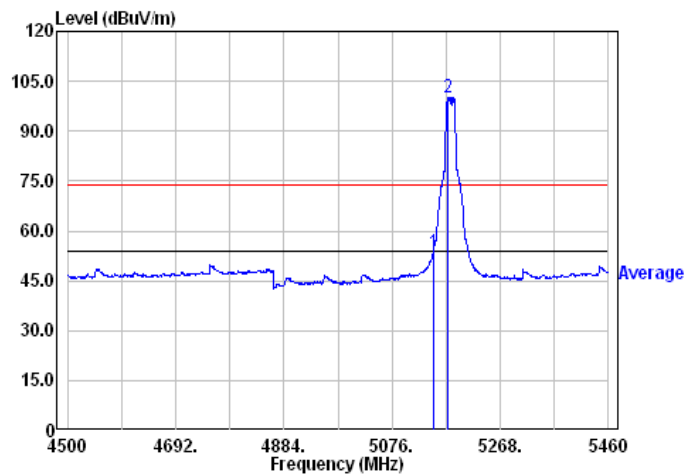

Chain0+1 : Restricted Band Bandedge @ 802.11a Mode Ch48 PK

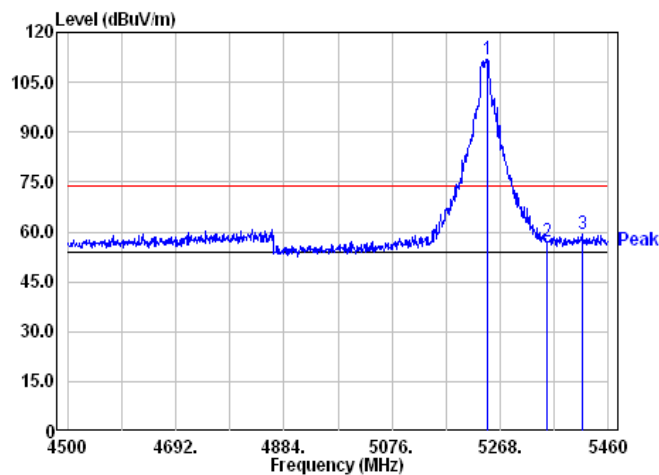

Chain0+1 : Restricted Band Bandedge @ 802.11a Mode Ch48 AV

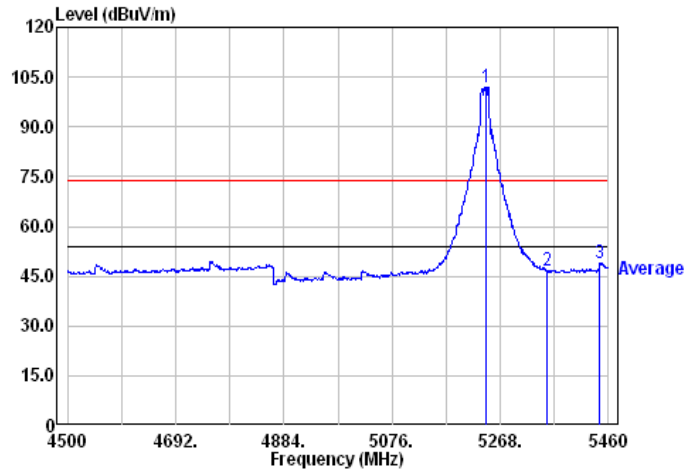

Chain0+1 : Restricted Band Bandedge @ 802.11ac(VHT20) Mode Ch36 PK

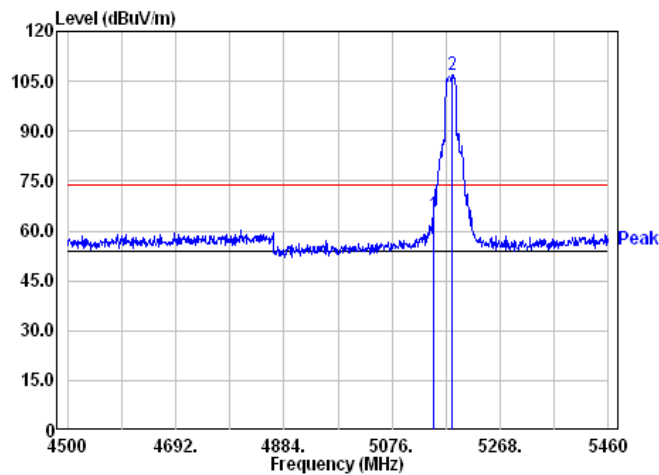

Chain0+1 : Restricted Band Bandedge @ 802.11ac(VHT20) Mode Ch36 AV

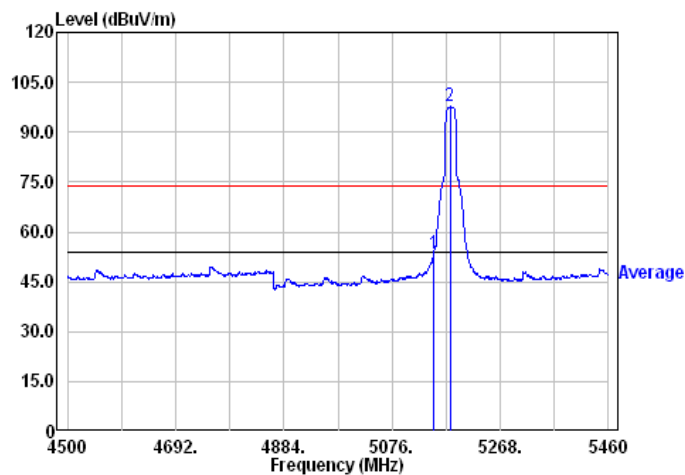

Chain0+1 : Restricted Band Bandedge @ 802.11ac(VHT20) Mode Ch48 PK

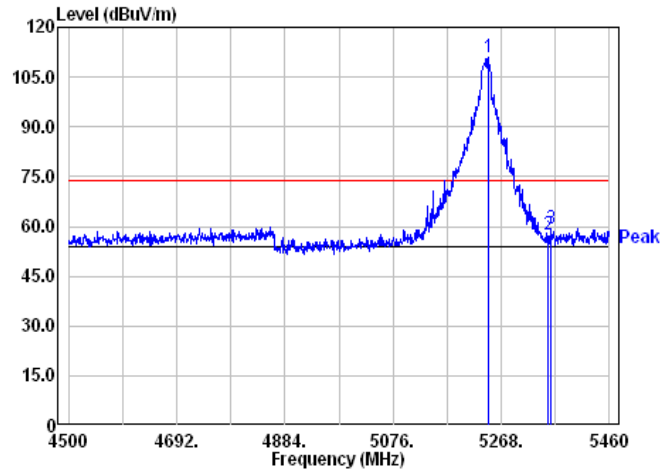

Chain0+1 : Restricted Band Bandedge @ 802.11ac(VHT20) Mode Ch48 AV

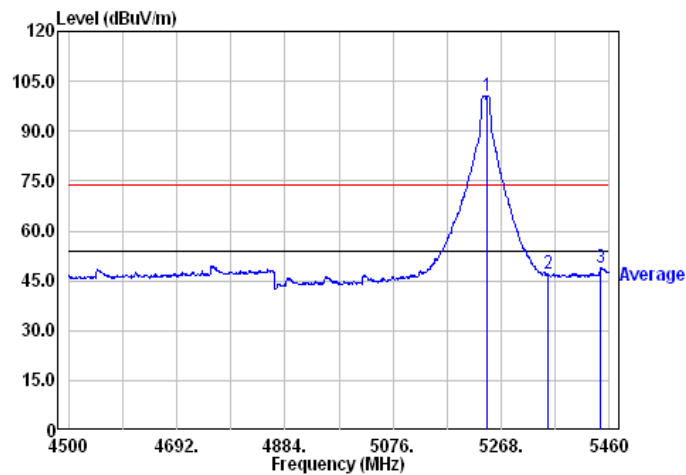

Chain0+1 : Restricted Band Bandedge @ 802.11ac(VHT40) Mode Ch38 PK

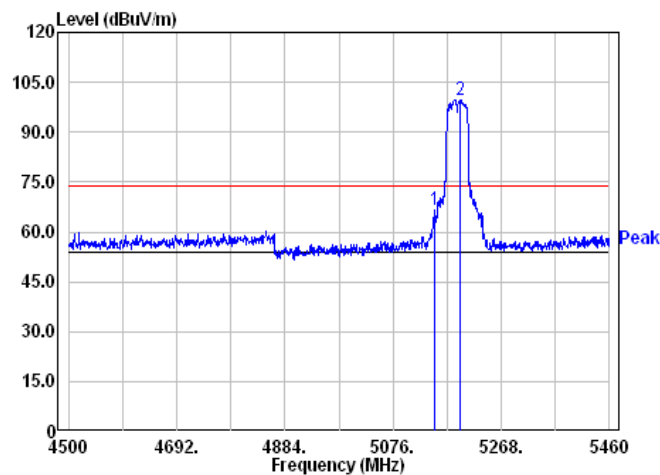

Chain0+1 : Restricted Band Bandedge @ 802.11ac(VHT40) Mode Ch38 AV

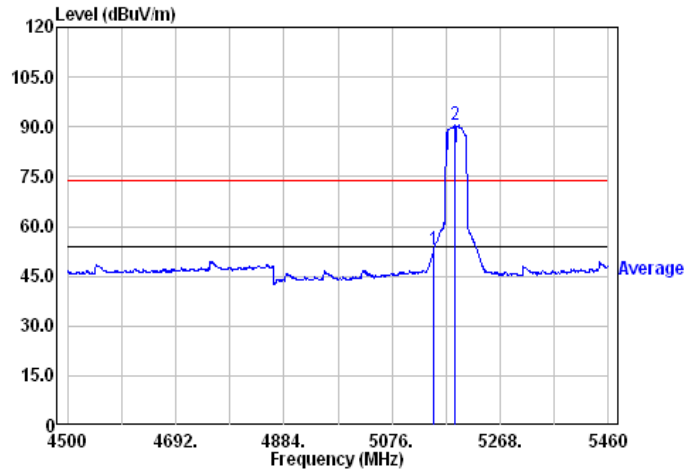

Chain0+1 : Restricted Band Bandedge @ 802.11ac(VHT40) Mode Ch46 PK

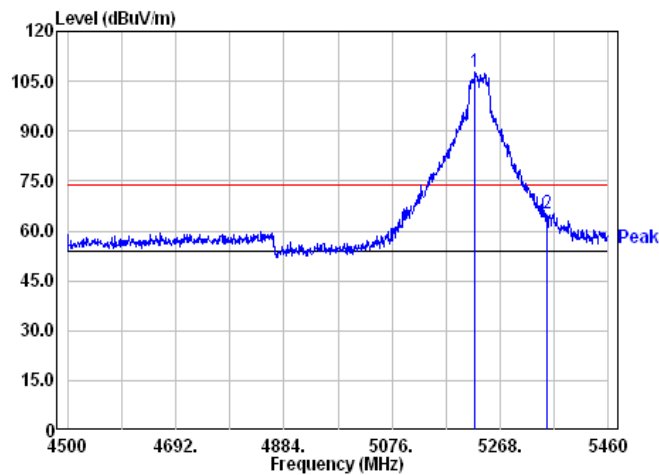

Chain0+1 : Restricted Band Bandedge @ 802.11ac(VHT40) Mode Ch46 AV

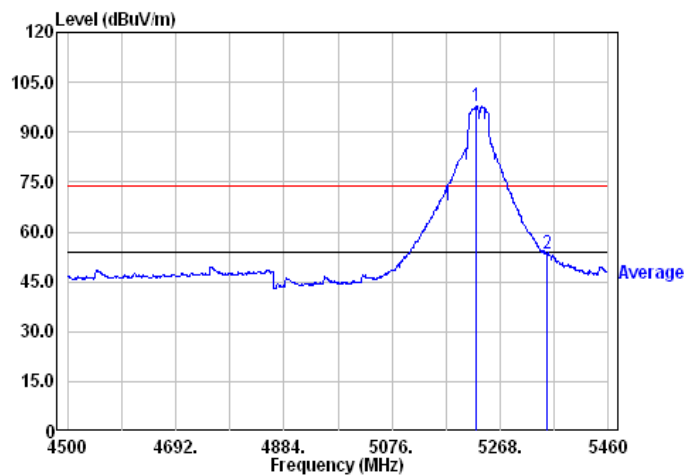

Chain0+1 : Restricted Band Bandedge @ 802.11ac(VHT80) Mode Ch42 PK

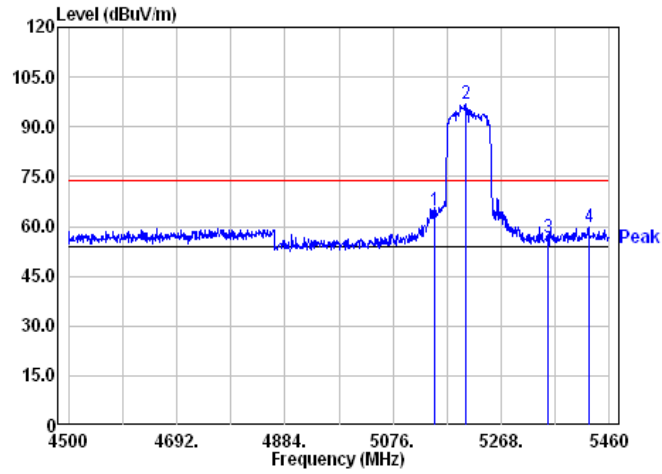

Chain0+1 : Restricted Band Bandedge @ 802.11ac(VHT80) Mode Ch42 AV

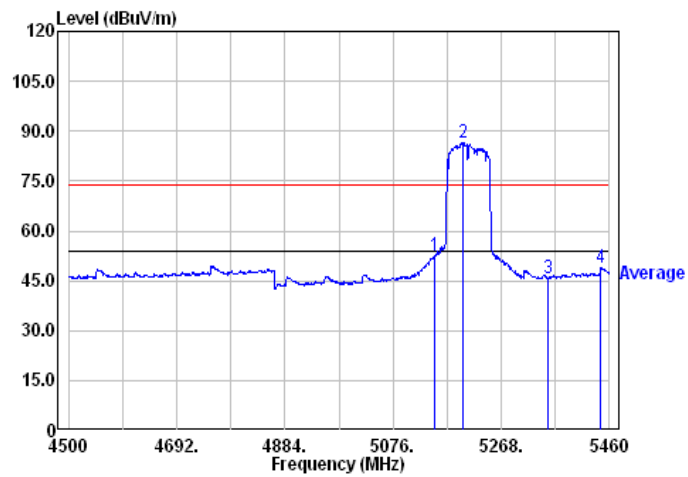

Chain0+1 : Out-of-band emission limits for U-NII-3 @ mode 802.11a Ch149

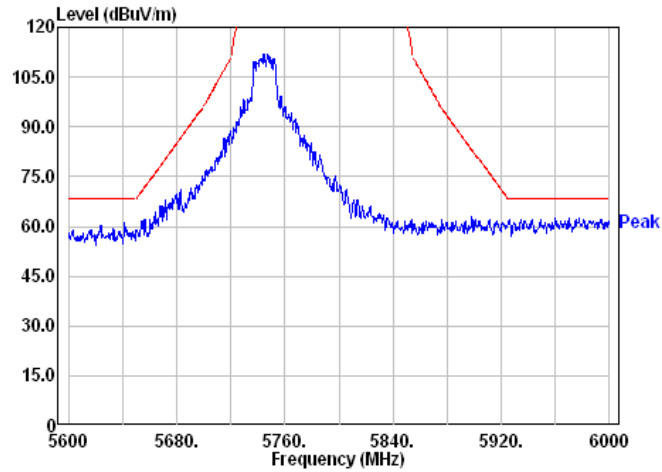

Chain0+1 : Out-of-band emission limits for U-NII-3 @ mode 802.11a Ch157

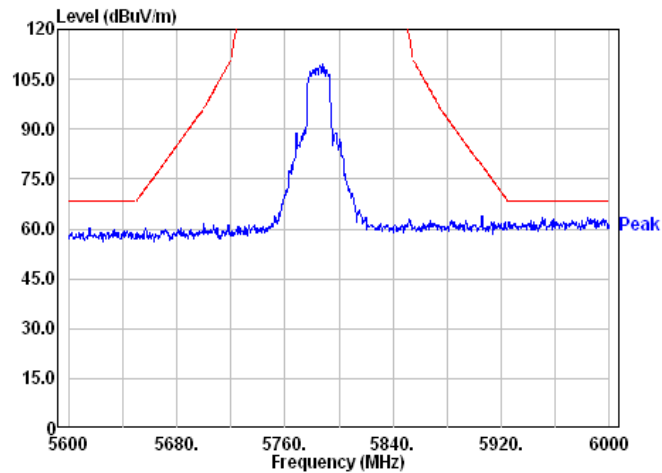

Chain0+1 : Out-of-band emission limits for U-NII-3 @ mode 802.11a Ch165

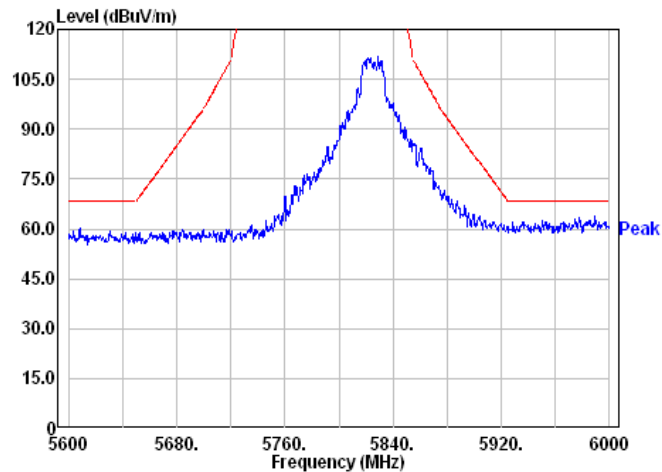

Chain0+1 : Out-of-band emission limits for U-NII-3 @ mode 802.11ac(VHT20) Ch149

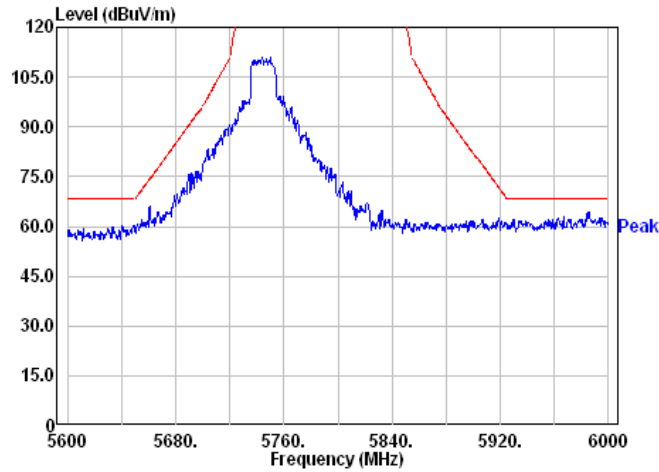

Chain0+1 : Out-of-band emission limits for U-NII-3 @ mode 802.11ac(VHT20) Ch157

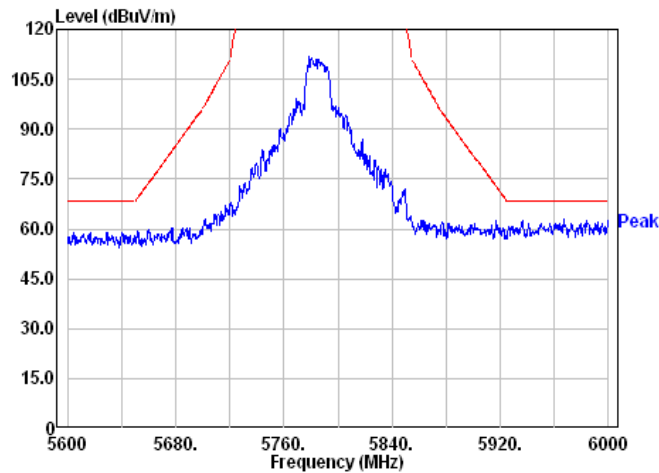

Chain0+1 : Out-of-band emission limits for U-NII-3 @ mode 802.11ac(VHT20) Ch165

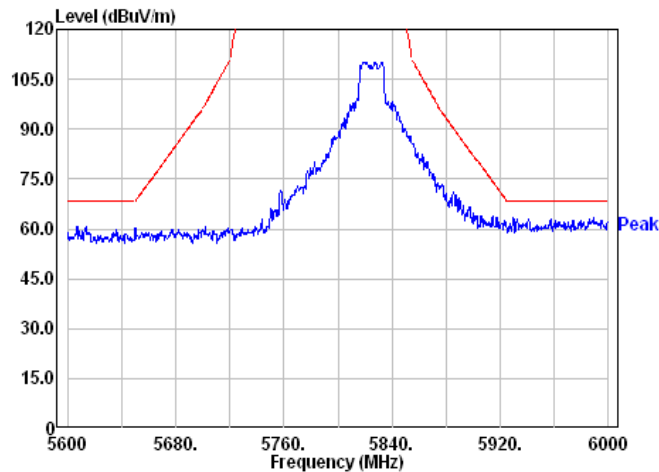

Chain0+1 : Out-of-band emission limits for U-NII-3 @ mode 802.11ac(VHT40) Ch151

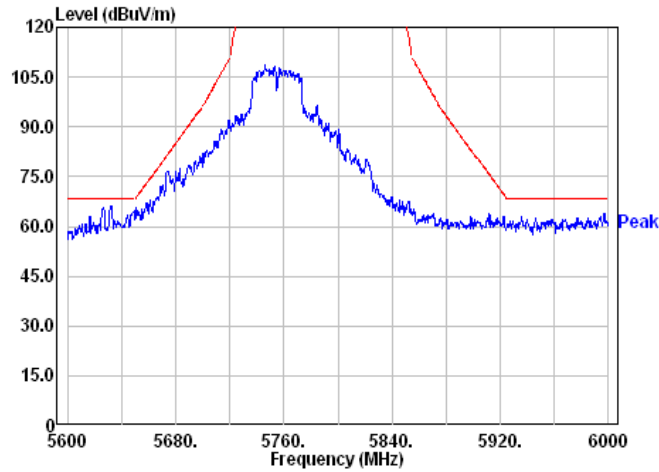

Chain0+1 : Out-of-band emission limits for U-NII-3 @ mode 802.11ac(VHT40) Ch159

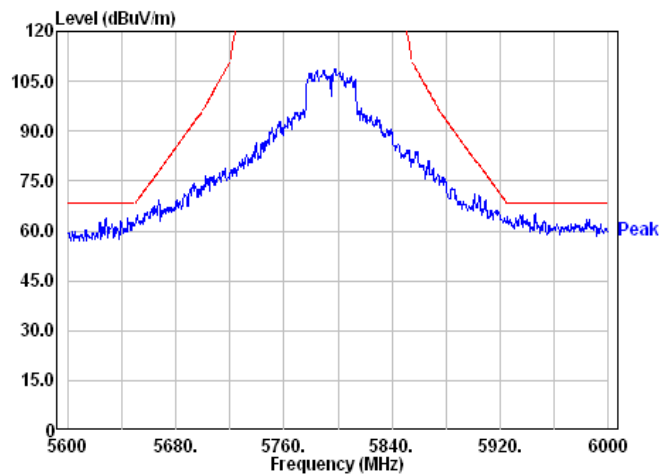

Chain0+1 : Out-of-band emission limits for U-NII-3 @ mode 802.11ac(VHT80) Ch155

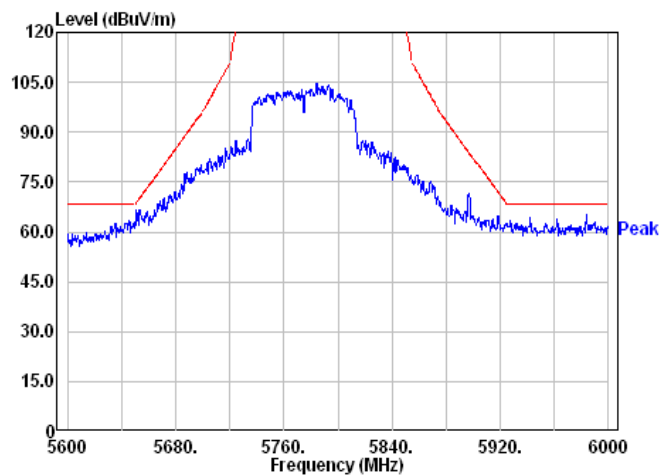

Temperature (°C) :	24
Relative Humidity (%) :	60
Test date :	2022/05/24
Host 2 :	67301

Mode	Frequency (MHz)	Spectrum Analyzer Detector	Ant. Pol. (H/V)	Correction Factor (dB/m)	Reading (dBμV)	Corrected Reading (dBμV/m)	Limit @ 3 m (dBμV/m)	Margin (dB)	Restricted band (MHz)
802.11a	5150.00	PK	H	41.96	22.47	64.43	74	-9.57	4500~5150
	5150.00	AV	H	41.96	10.08	52.04	54	-1.96	
	5358.24	PK	H	41.62	16.26	57.88	74	-16.12	5350~5460
	5350.00	AV	H	41.59	2.09	43.68	54	-10.32	
802.11ac(VHT20)	5150.00	PK	H	41.96	16.31	58.27	74	-15.73	4500~5150
	5150.00	AV	H	41.96	10.48	52.44	54	-1.56	
	5405.28	PK	H	41.75	10.31	52.06	74	-21.94	5350~5460
	5350.00	AV	H	41.59	-0.60	40.99	54	-13.01	
802.11ac(VHT40)	5150.00	PK	H	41.96	21.45	63.41	74	-10.59	4500~5150
	5150.00	AV	H	41.96	11.08	53.04	54	-0.96	
	5350.00	PK	H	41.59	19.26	60.85	74	-13.15	5350~5460
	5350.00	AV	H	41.59	10.10	51.69	54	-2.31	
802.11ac(VHT80)	5150.00	PK	H	41.96	27.16	69.12	74	-4.88	4500~5150
	5150.00	AV	H	41.96	11.07	53.03	54	-0.97	
	5350.00	PK	H	41.59	9.98	51.57	74	-22.43	5350~5460
	5350.00	AV	H	41.59	-1.38	40.21	54	-13.79	

Remark: Correction Factor = Antenna Factor + Cable Loss - Pre_Amplifier Gain

Chain0+1 : Restricted Band Bandedge @ 802.11a Mode Ch36 PK

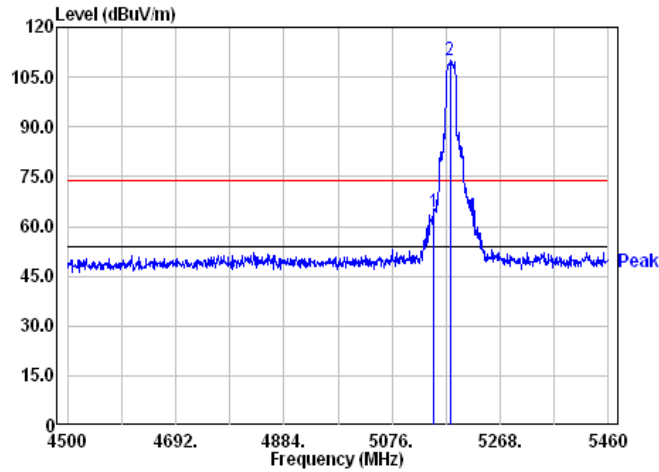

Chain0+1 : Restricted Band Bandedge @ 802.11a Mode Ch36 AV

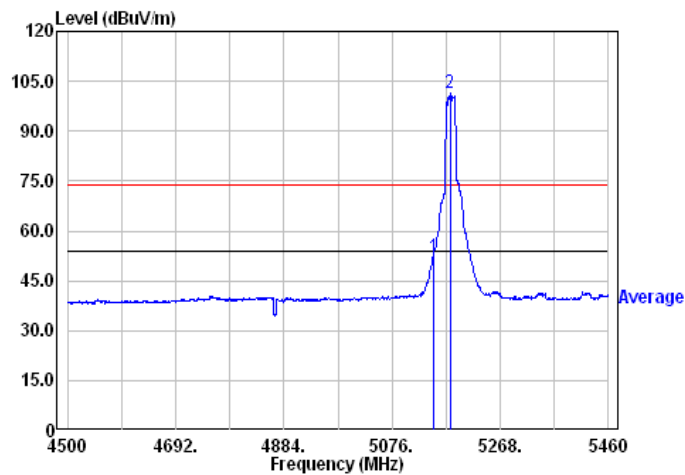

Chain0+1 : Restricted Band Bandedge @ 802.11a Mode Ch48 PK

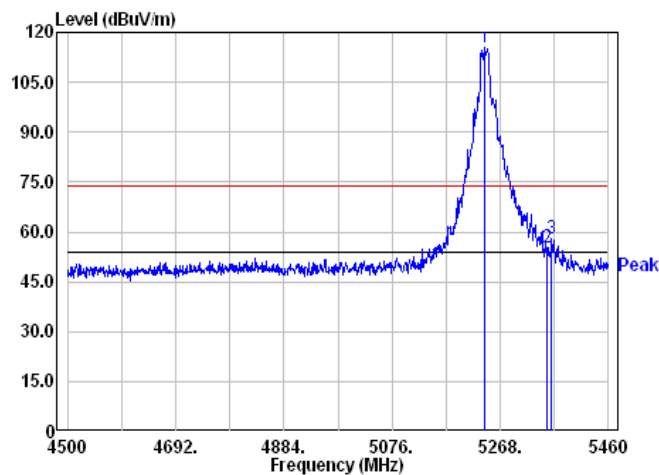

Chain0+1 : Restricted Band Bandedge @ 802.11a Mode Ch48 AV

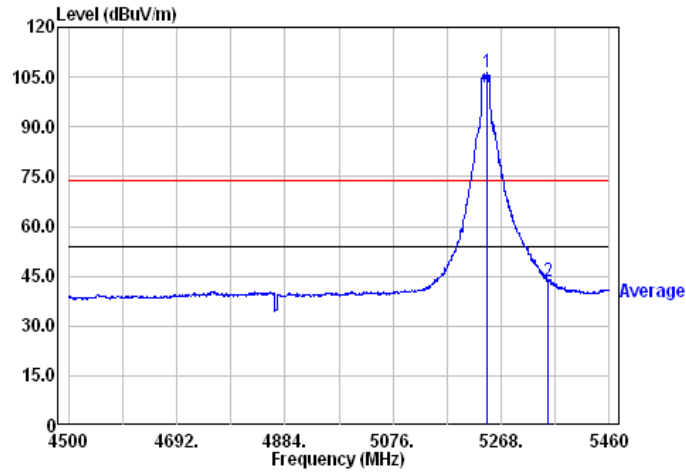

Chain0+1 : Restricted Band Bandedge @ 802.11ac(VHT20) Mode Ch36 PK

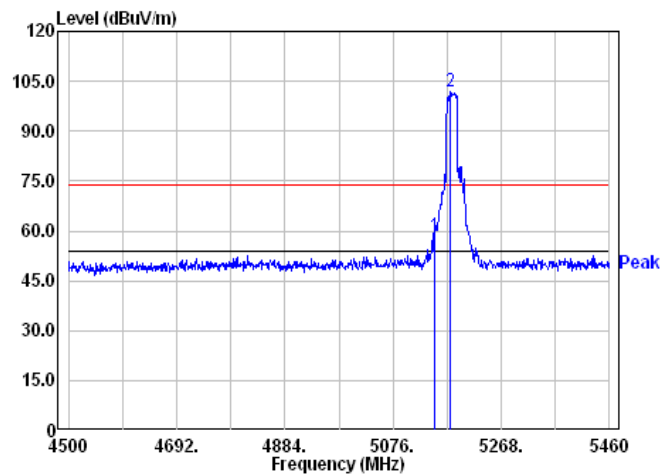

Chain0+1 : Restricted Band Bandedge @ 802.11ac(VHT20) Mode Ch36 AV

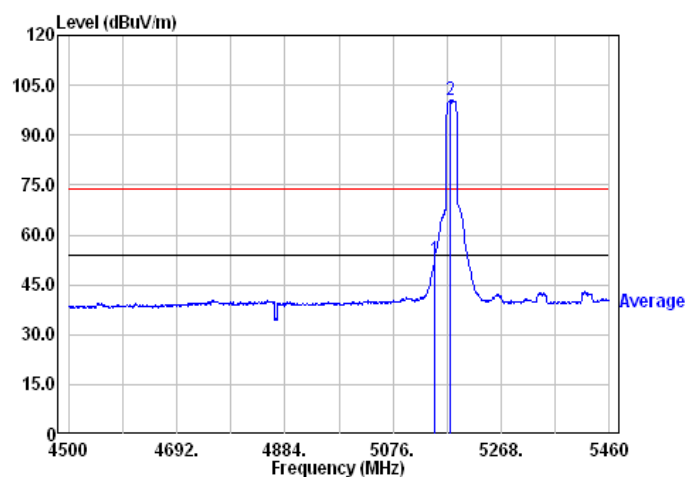

Chain0+1 : Restricted Band Bandedge @ 802.11ac(VHT20) Mode Ch48 PK

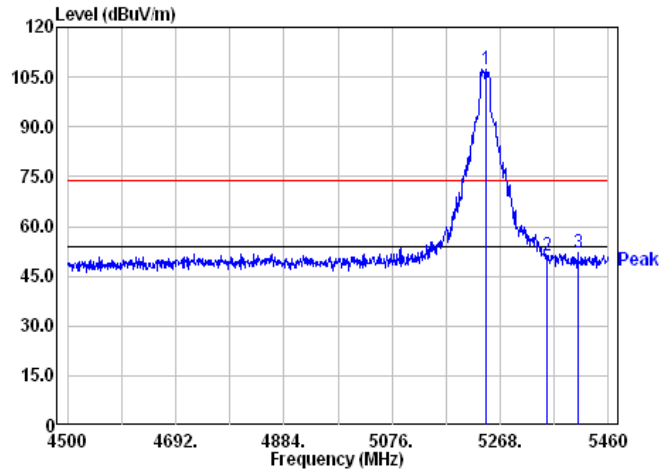

Chain0+1 : Restricted Band Bandedge @ 802.11ac(VHT20) Mode Ch48 AV

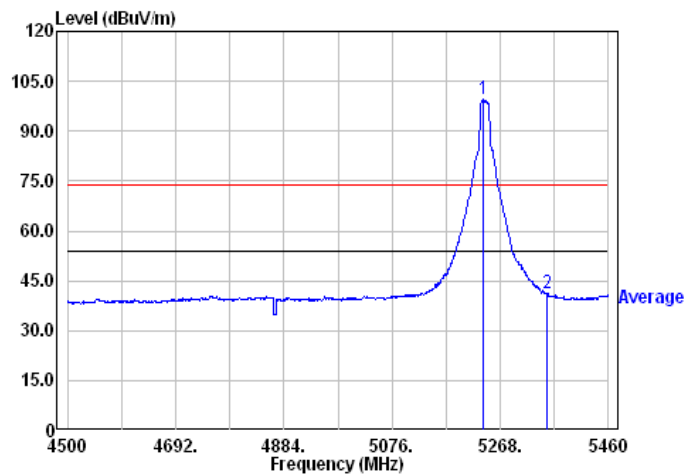

Chain0+1 : Restricted Band Bandedge @ 802.11ac(VHT40) Mode Ch38 PK

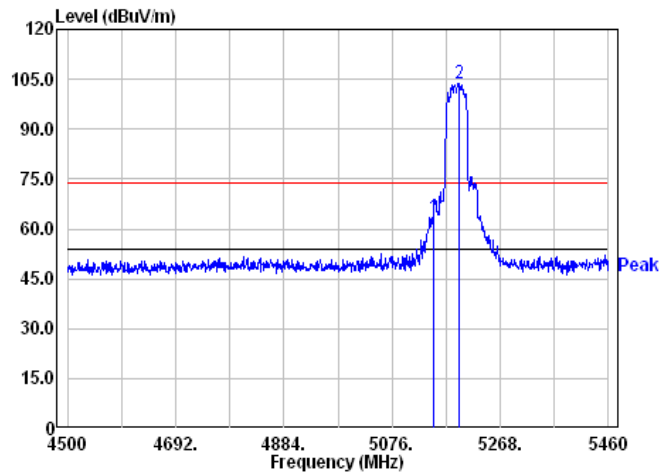

Chain0+1 : Restricted Band Bandedge @ 802.11ac(VHT40) Mode Ch38 AV

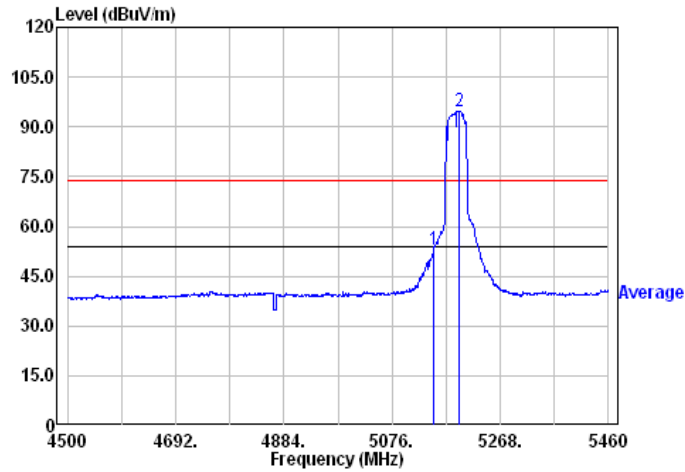

Chain0+1 : Restricted Band Bandedge @ 802.11ac(VHT40) Mode Ch46 PK

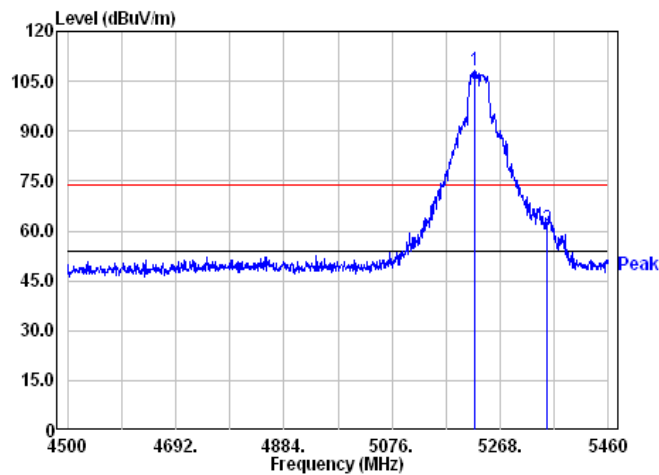

Chain0+1 : Restricted Band Bandedge @ 802.11ac(VHT40) Mode Ch46 AV

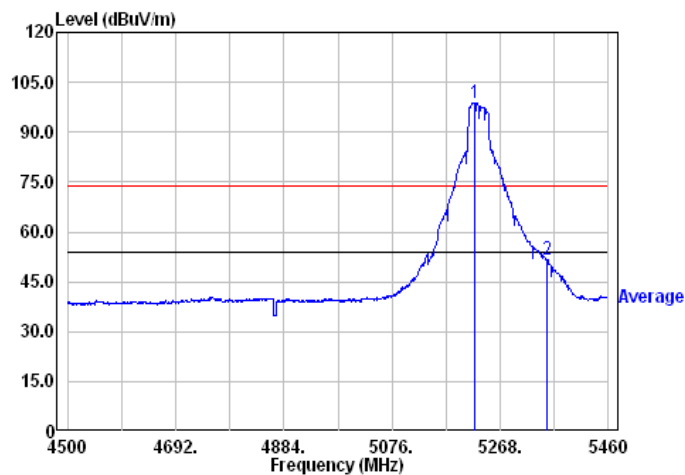

Chain0+1 : Restricted Band Bandedge @ 802.11ac(VHT80) Mode Ch42 PK

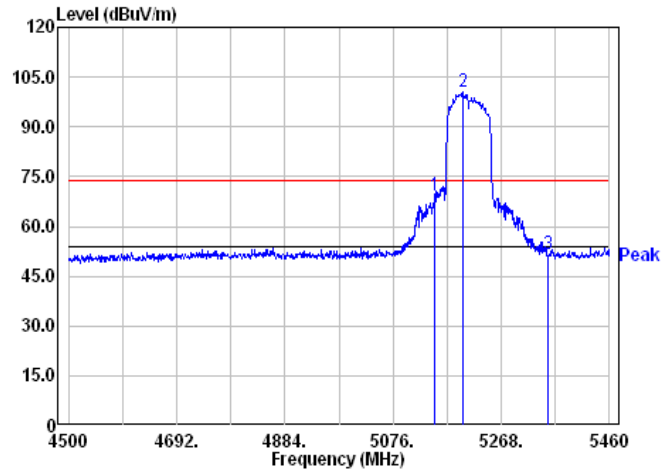

Chain0+1 : Restricted Band Bandedge @ 802.11ac(VHT80) Mode Ch42 AV

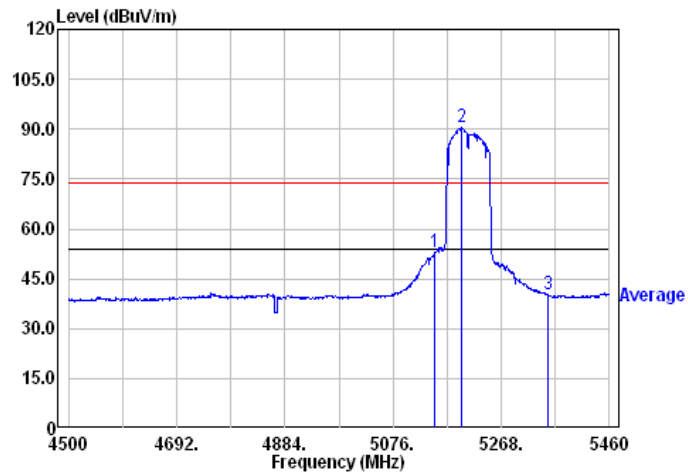

Chain0+1 : Out-of-band emission limits for U-NII-3 @ mode 802.11a Ch149

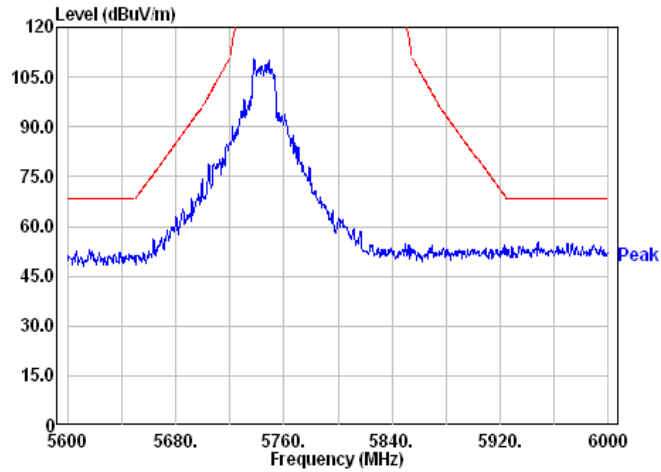

Chain0+1 : Out-of-band emission limits for U-NII-3 @ mode 802.11a Ch157

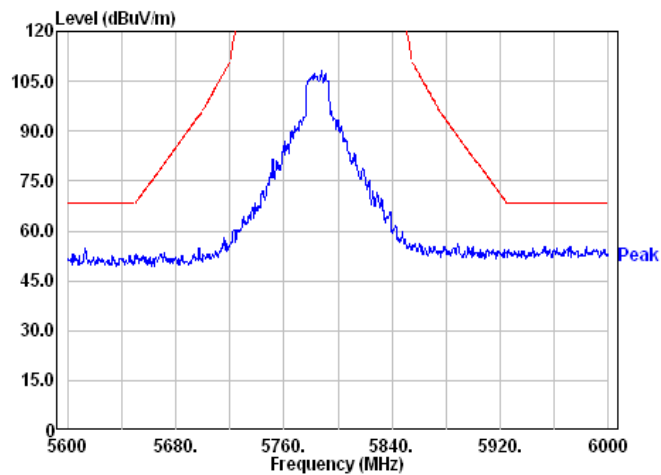

Chain0+1 : Out-of-band emission limits for U-NII-3 @ mode 802.11a Ch165

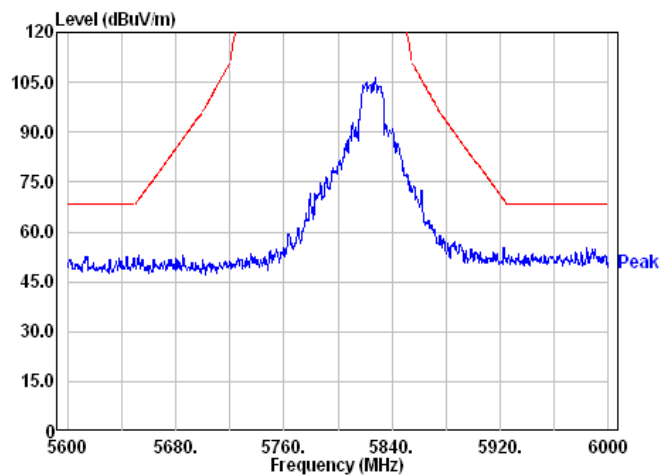

Chain0+1 : Out-of-band emission limits for U-NII-3 @ mode 802.11ac(VHT20) Ch149

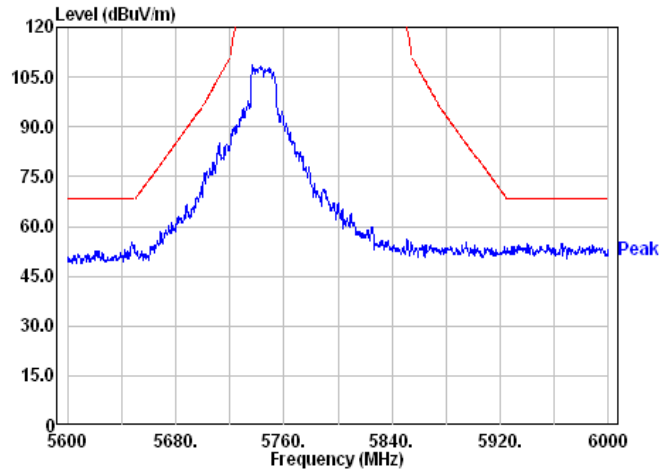

Chain0+1 : Out-of-band emission limits for U-NII-3 @ mode 802.11ac(VHT20) Ch157

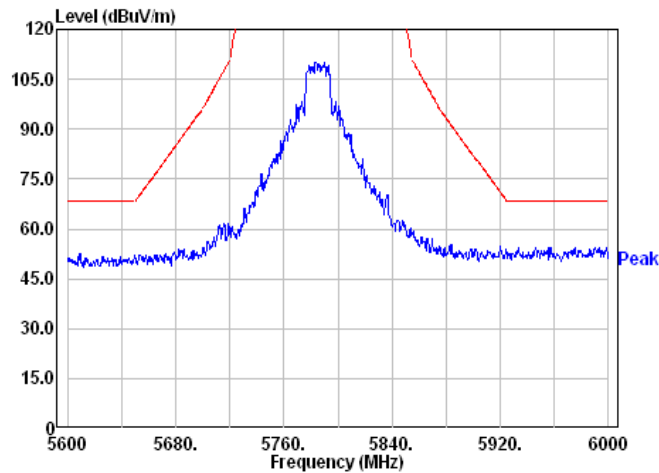

Chain0+1 : Out-of-band emission limits for U-NII-3 @ mode 802.11ac(VHT20) Ch165

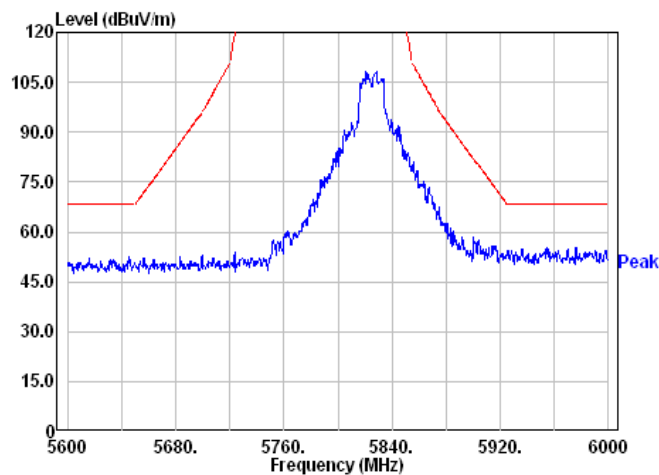

Chain0+1 : Out-of-band emission limits for U-NII-3 @ mode 802.11ac(VHT40) Ch151

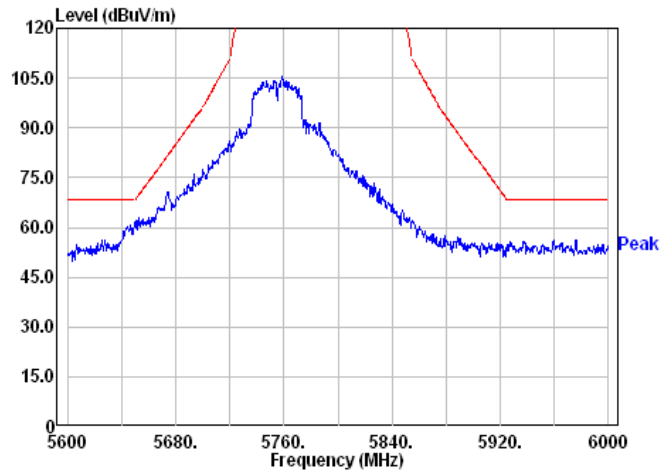

Chain0+1 : Out-of-band emission limits for U-NII-3 @ mode 802.11ac(VHT40) Ch159

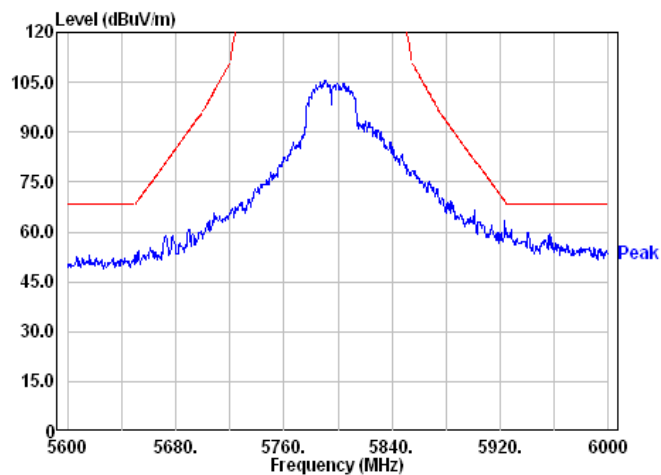

Chain0+1 : Out-of-band emission limits for U-NII-3 @ mode 802.11ac(VHT80) Ch155

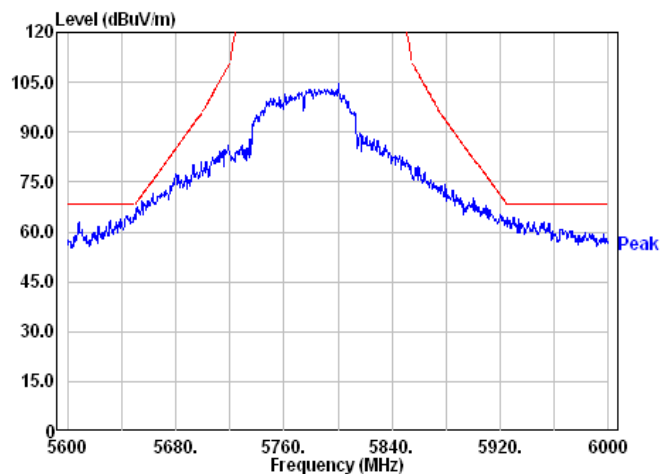

7. AC Power Line Conducted Emission

7.1 Measuring instrument setting

Receiver Function	Setting
Detector	QP
Start frequency	0.15MHz
Stop frequency	30MHz
IF bandwidth	9 kHz
Attenuation	10dB

7.2 Test Procedure

Step 1	Configure the EUT according to ANSI C63.10:2013. The EUT or host of EHT has to be placed 0.4 meter far from the conducting wall of the shielding room and at least 80 centimeters from any other grounded conducting surface.
Step 2	Connect EUT or host of EUT to the power mains through a line impedance stabilization network.
Step 3	All the companion devices are connected to the other LISN. The LISN should provide 50Uh/50ohms coupling impedance.
Step 4	The frequency range from 150 kHz to 30MHz was searched.
Step 5	Set the test-receiver system to peak detector and specified bandwidth with maximum hold mode.
Step 6	The measurement has to be done between each power line and ground at the power terminal.

7.3 Test Diagram

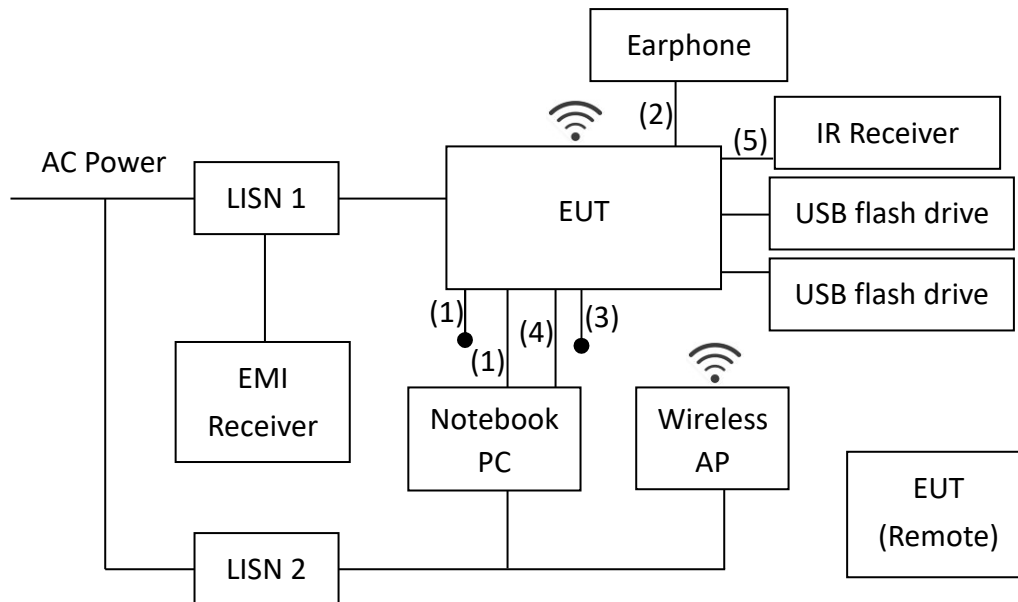

- (1) Shielded HDMI cable 1.5m
- (2) Unshielded audio 3.5mm cable 2m
- (3) RS-232 cable 1.5m
- (4) RJ45 UTP CAT.5 cable 2m
- (5) IR cable 2m

7.4 Limit

Frequency (MHz)	Conducted Limit (dBuV)	
	Q.P.	Ave.
0.15~0.50	66 – 56	56 – 46
0.50~5.00	56	46
5.00~30.0	60	50

TEST REPORT

7.5 Test Results

Model No.:	FBP205
Host 1 :	67401

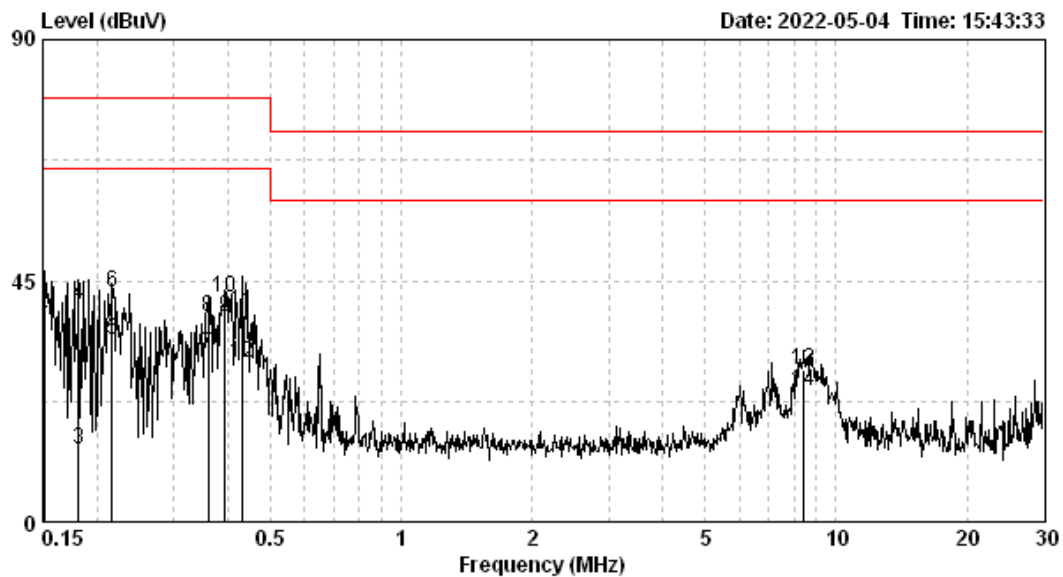

Test voltage :AC 120V/60Hz
 Temp. / R.H. :23°C / 52%RH
 Atmospheric pressure :1008hPa

Phase	Frequency (MHz)	Corr. Factor (dB)	Reading QP (dBUV)	Level QP (dBUV)	Limit QP (dBUV)	Reading AV (dBUV)	Level AV (dBUV)	Limit AV (dBUV)	Margin (dB)	
									QP	AV
LINE	0.151	9.62	34.55	44.17	79.00	29.38	39.00	66.00	-34.83	-27.00
LINE	0.182	9.63	30.95	40.58	79.00	3.87	13.51	66.00	-38.42	-52.49
LINE	0.216	9.66	33.16	42.82	79.00	24.20	33.85	66.00	-36.18	-32.15
LINE	0.360	9.76	28.47	38.24	79.00	21.47	31.23	66.00	-40.76	-34.77
LINE	0.393	9.78	32.03	41.81	79.00	28.38	38.16	66.00	-37.19	-27.84
LINE	0.433	9.80	29.37	39.17	79.00	19.89	29.69	66.00	-39.83	-36.31
LINE	8.456	9.84	18.58	28.42	73.00	14.47	24.31	60.00	-44.58	-35.69

Remark:

1. Corr. Factor (dB) = LISN Factor (dB) + Cable Loss (dB)
2. Level (dBUV) = Corr. Factor (dB) + Reading (dBUV)
3. Margin (dB) = Level (dBUV) – Limit (dBUV)

TEST REPORT

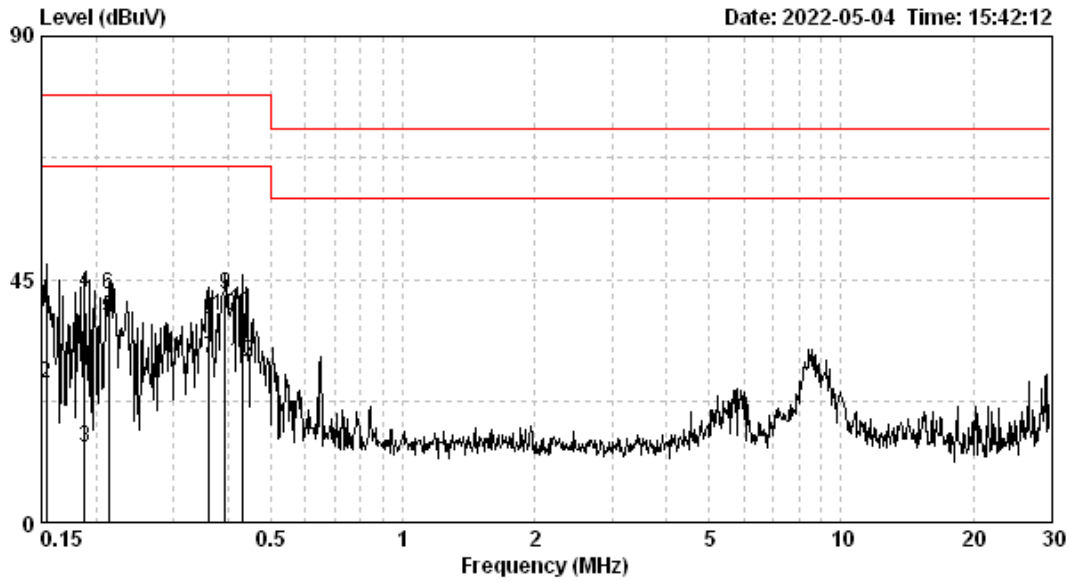

Test voltage :AC 120V/60Hz
 Temp. / R.H. :23°C / 52%RH
 Atmospheric pressure :1008hPa

Phase	Frequency (MHz)	Corr. Factor (dB)	Reading QP (dBuV)	Level QP (dBuV)	Limit QP (dBuV)	Reading AV (dBuV)	Level AV (dBuV)	Limit AV (dBuV)	Margin (dB)	
									QP	AV
NEUTRAL	0.154	9.63	29.91	39.53	79.00	15.99	25.61	66.00	-39.47	-40.39
NEUTRAL	0.188	9.64	33.05	42.68	79.00	4.31	13.95	66.00	-36.32	-52.05
NEUTRAL	0.214	9.66	32.45	42.10	79.00	28.26	37.92	66.00	-36.90	-28.08
NEUTRAL	0.361	9.76	27.80	37.56	79.00	20.59	30.35	66.00	-41.44	-35.65
NEUTRAL	0.393	9.78	32.47	42.25	79.00	28.56	38.34	66.00	-36.75	-27.66
NEUTRAL	0.433	9.80	29.29	39.09	79.00	19.81	29.61	66.00	-39.91	-36.39

Remark:

1. Corr. Factor (dB) = LISN Factor (dB) + Cable Loss (dB)
2. Level (dBuV) = Corr. Factor (dB) + Reading (dBuV)
3. Margin (dB) = Level (dBuV) – Limit (dBuV)

TEST REPORT

Model No.:	FBP205
Host 2 :	67301

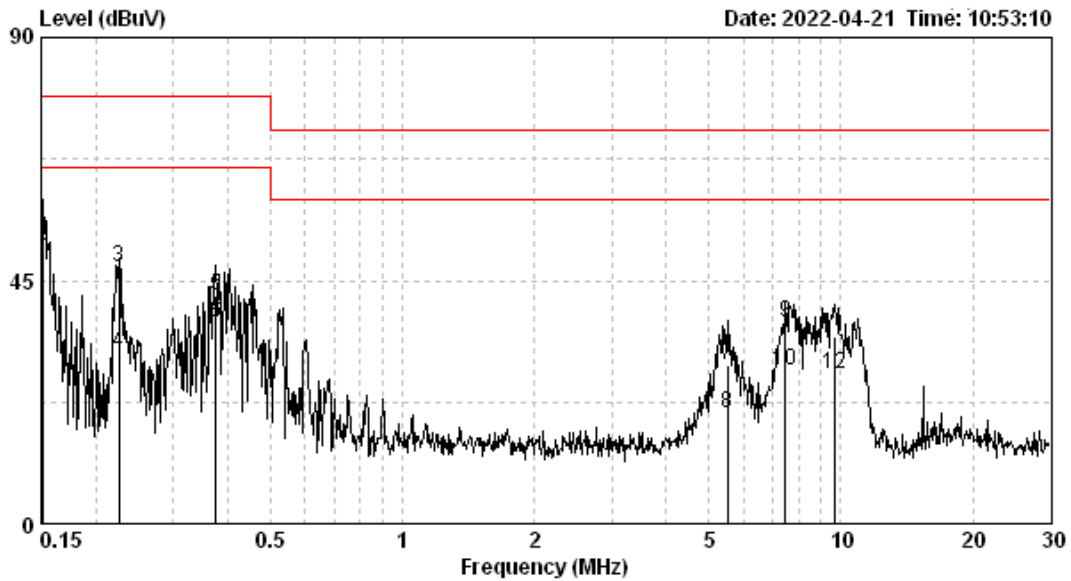

Test voltage : AC 120V/60Hz
 Temp. / R.H. : 23°C / 61%RH
 Atmospheric pressure : 1008hPa

Phase	Frequency (MHz)	Corr. Factor (dB)	Reading QP (dBuV)	Level QP (dBuV)	Limit QP (dBuV)	Reading AV (dBuV)	Level AV (dBuV)	Limit AV (dBuV)	Margin (dB)	
									QP	AV
LINE	0.151	9.62	48.36	57.98	79.00	41.93	51.55	66.00	-21.02	-14.45
LINE	0.226	9.67	37.66	47.33	79.00	22.07	31.74	66.00	-31.67	-34.26
LINE	0.375	9.77	32.53	42.30	79.00	27.49	37.26	66.00	-36.70	-28.74
LINE	5.505	9.82	19.68	29.50	73.00	10.68	20.51	60.00	-43.50	-39.49
LINE	7.486	9.84	27.26	37.10	73.00	18.62	28.46	60.00	-35.90	-31.54
LINE	9.654	9.85	24.90	34.75	73.00	17.97	27.82	60.00	-38.25	-32.18

Remark:

1. Corr. Factor (dB) = LISN Factor (dB) + Cable Loss (dB)
2. Level (dBuV) = Corr. Factor (dB) + Reading (dBuV)
3. Margin (dB) = Level (dBuV) – Limit (dBuV)

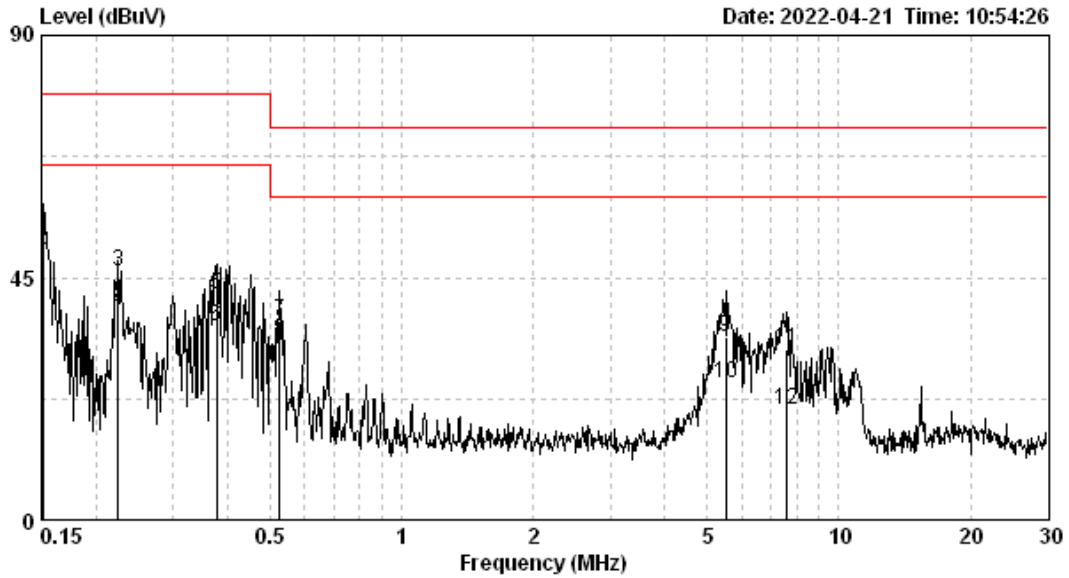

Test voltage :AC 120V/60Hz
 Temp. / R.H. :23°C / 61%RH
 Atmospheric pressure :1008hPa

Phase	Frequency (MHz)	Corr. Factor (dB)	Reading	Level	Limit	Reading	Level	Limit	Margin (dB)	
			QP (dBuV)	QP (dBuV)	QP (dBuV)	AV (dBuV)	AV (dBuV)	AV (dBuV)	QP	AV
NEUTRAL	0.151	9.62	47.73	57.35	79.00	40.33	49.96	66.00	-21.65	-16.04
NEUTRAL	0.224	9.67	36.50	46.16	79.00	29.16	38.82	66.00	-32.84	-27.18
NEUTRAL	0.377	9.77	32.15	41.93	79.00	26.17	35.94	66.00	-37.07	-30.06
NEUTRAL	0.527	9.83	27.01	36.84	73.00	23.39	33.22	60.00	-36.16	-26.78
NEUTRAL	5.505	9.83	24.03	33.86	73.00	15.56	25.39	60.00	-39.14	-34.61
NEUTRAL	7.606	9.84	21.89	31.73	73.00	10.70	20.54	60.00	-41.27	-39.46

Remark:

1. Corr. Factor (dB) = LISN Factor (dB) + Cable Loss (dB)
2. Level (dBuV) = Corr. Factor (dB) + Reading (dBuV)
3. Margin (dB) = Level (dBuV) – Limit (dBuV)

Appendix A: Test equipment list

Test Equipment/ Test site	Brand	Model No.	Serial No.	Calibration Date	Next Calibration Date
EMI Test Receiver	Rohde & Schwarz	ESR7	101822	2021/08/16	2022/08/15
Signal Analyzer	Agilent	N9030A	MY51380492	2021/08/17	2022/08/16
Active Loop Antenna	SCHWARZBECK MESS-ELEKTRONIC	FMZB1519	1519-067	2022/04/13	2023/04/12
Broadband Antenna	SHWARZBECK	VULB 9168	9168-172	2022/01/20	2023/01/19
Horn Antenna	EMCO	BBHA 9120 D	9120D-456	2022/01/21	2023/01/20
Horn Antenna	SCHWARZBECK	BBHA 9170	BBHA9170159	2021/04/08	2024/04/07
Broadband Amplifier	SGH	SGH118(45dB)	20220105-1	2022/01/07	2023/01/06
Pre-amplifier	SGH	SGH184	20201124-1	2021/12/06	2022/12/05
Power Meter	Anritsu	ML2495A	0844001	2021/10/17	2022/10/16
Power Sensor	Anritsu	MA2491A	031543	2022/03/07	2023/03/06
966-2(A) Cable	SUHNER	SMA / EX 100	N/A	2022/03/04	2023/03/03
966-2(B) Cable	SUHNER	SUCOFLEX 104P	CB0005	2022/03/04	2023/03/03
966-2 Cable	SUHNER	SUCOFLEX 104P	9403/4P	2021/11/30	2022/11/29
966-2_3m Semi-Anechoic Chamber	966_2	CEM-966_2	N/A	2022/01/14	2023/01/13
Hight Pass Filter	Reactel	7HS-3G/18G-S11	N/A	2021/05/26	2022/05/25
20dB Attenuator	Mini-Circuits	BW-S20W5+	N/A	2021/05/26	2022/05/25
Test software	Audix	e3	V9	NCR	NCR

Note: No Calibration Required (NCR).

TEST REPORT

Test Equipment	Brand	Model No.	Serial No.	Calibration Date	Next Calibration Date
EMI Test Receiver	R&S	ESCI	100018	2021/11/16	2022/11/15
LISN	R&S	ENV216	101160	2021/07/14	2022/07/13
LISN	R&S	ESH3-Z5	835239/023	2021/09/22	2022/09/21
CON-2 Cable	SUHNER	EMCCFD300-B M-NM-6000	170502	2021/04/29	2022/04/28
Test software	Audix	e3	V4.20040112L	NCR	NCR

Note: No Calibration Required (NCR).

Appendix B: Measurement Uncertainty

This uncertainty represents an expanded uncertainty expressed at approximately the 95 % confidence level using a coverage factor of $k=2$.

Item	Uncertainty
Vertically polarized radiated disturbances from 30MHz~1GHz in a semi-anechoic chamber at a distance of 3m	5.16 dB
Horizontally polarized radiated disturbances from 30MHz~1GHz in a semi-anechoic chamber at a distance of 3m	5.02 dB
Radiated disturbances from 1GHz~18GHz in a semi-anechoic chamber at a distance of 3m	5.17 dB
Vertically polarized Radiated disturbances from 18GHz~26.5GHz in a semi-anechoic chamber at a distance of 1m	2.39 dB
Horizontally polarized Radiated disturbances from 18GHz~26.5GHz in a semi-anechoic chamber at a distance of 1m	2.39 dB
Vertically polarized Radiated disturbances from 26.5GHz~40GHz in a semi-anechoic chamber at a distance of 1m	2.39 dB
Horizontally polarized Radiated disturbances from 26.5GHz~40GHz in a semi-anechoic chamber at a distance of 1m	2.39 dB
Radiated disturbances from 9kHz~30MHz in a semi-anechoic chamber at a distance of 3m	3.70 dB
Emission on the Band Edge Test	4.32 dB
Minimum Emission Bandwidth	7.78 %
Maximum Conducted Output Power	1.27 dB
Power Spectral Density	1.27 dB
AC Power Line Conducted Emission	3.08 dB