



Dongguan YiJia Electronics Communication Technology Co.,Ltd.

SPECIFICATION FOR APPROVAL

Date 2021/09/27
 File No 21092701
 Revision 1.0

Guide

CUSTOMER: _____

ZG11A

CUSTOMER NO: _____

PART NAME: WIFI Antenna L=65mm MHF

SUPPLIER NO: YJT01.220.003.301A

Date: _____

Q “TY:

CUSTOMER APPROVED BY		
APPROVAL	CHIEF	SUPERVISOR

SUPPLIER SIGNATURE		
APPROVAL	CHECK	DESIGN
 ChenGuoqiang	WenXue	ChenXingyi

YJ-RD-F04-A

RoHS

Compliant

CUSTOMER	
PART NO	

REV.	DESCRIPTION	DATE
△	首次发行	2021-08-10
△	修改丝印	2021-08-16

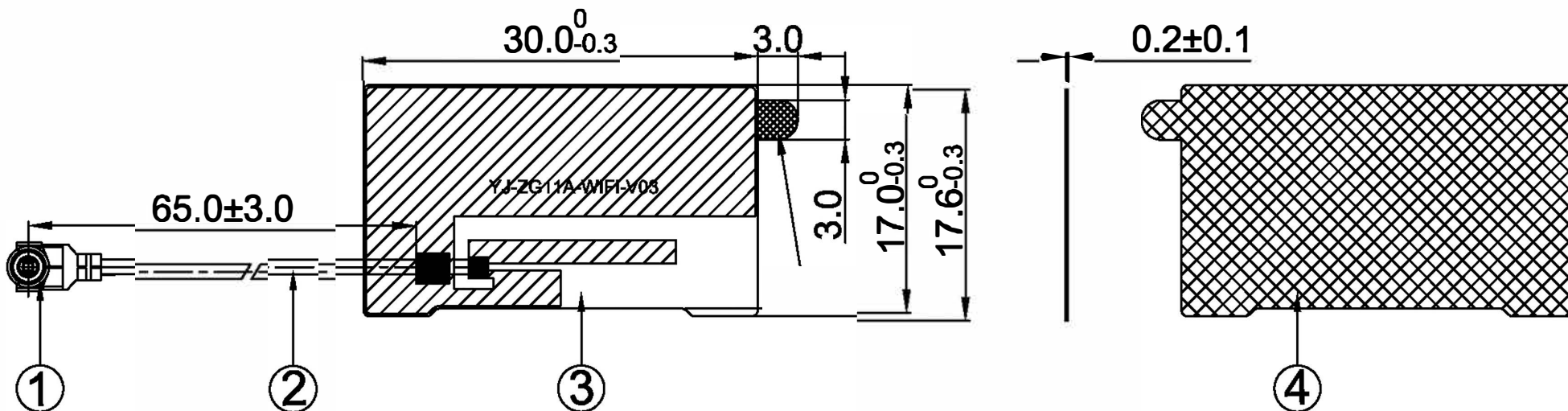

4	Paster	30.0*17.6MM	3M9448A	PAS10XXXA.P01	1
3	FPC	30.0*17.6MM	FPC	FPC10XXXA.P01	1
2	Coaxial Cable	O.D.1.13 Black	O.D.1.13	COA10XXXA.P01	1
1	Mini Connector	Au Plated 1	Cu	TER10XXXX.P01	1
NO	PART NAME	DESCRIPTION	Material	Part Number	Q.TY



Tel: 769-8258 086

Dongguan YiJia Electronics Communication Technology Co., Ltd. Fax: 0769-82586086

PART NAME: WIFI Antenna L=65mm MHF			
PART NO.: YJT01.220.003.301A		DATE: 2021-08-16	
APPROVED BY	CHECKED BY	DESIGNED BY	 Tolerance X.X ±0.50 X.XX ±0.15 X° ±3°
		SCALE: 1/	
			REVISION: B



Antenna Specification

Electrical Properties	
Frequency	2.4-2.5GHz
Impedance	50 Ohm Nominal
V.S.W.R	2.0 Max
Gain	1.2dBi
Radiation	Omni-directional
Polarization	Linear
Physical Properties	
Connector	IPEX
Cable Type	O.D.1.13mm
Cable Length	65mm
Cable Color	Black
Operating Temp.	-40 ~ +85 °C
Storage Temp / Humidity	25±5°C / <70%



Antenna Performance Test

**Agilent
E5071B**

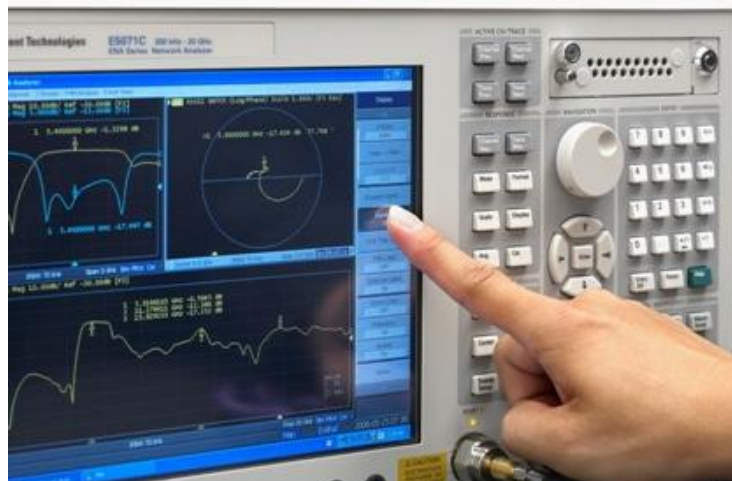

**S
Parameter
Test //
WiFi
Antenna**

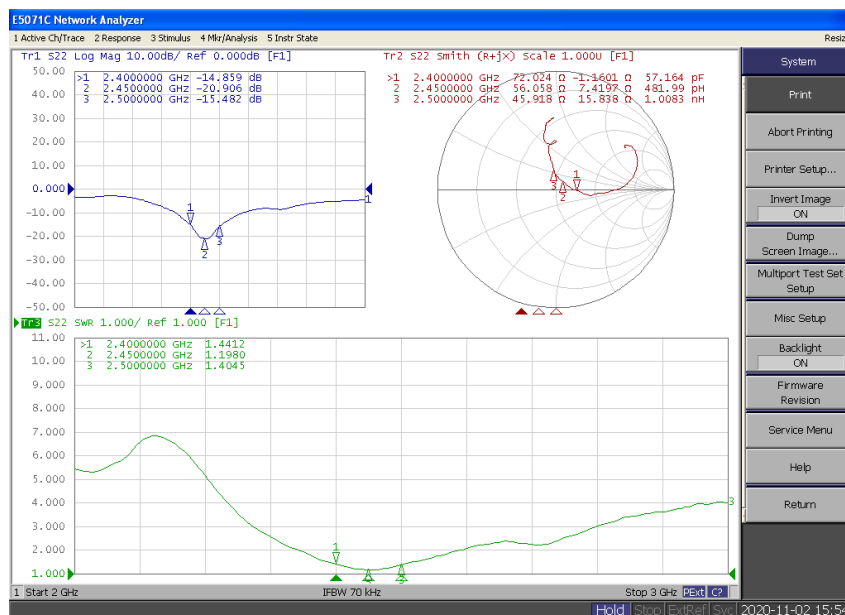

2020-11-02 15:54



Antenna Passive Test





Passive Test For WiFi Antenna

Freq (MHz)	Effi (%)	Effi (dB)	Gain (dBi)
2400	48.5	-3.1	1.2
2410	48.8	-3.1	1.1
2420	47.6	-3.2	0.9
2430	45.6	-3.4	0.8
2440	42.9	-3.7	0.9
2450	42.2	-3.8	0.7
2460	39.7	-4.0	0.8
2470	40.2	-4.0	0.6
2480	36.9	-4.3	0.1
2490	35.6	-4.5	-0.2
2500	33.3	-4.8	-0.7



Radiation Pattern For WiFi Antenna(2450MHz)

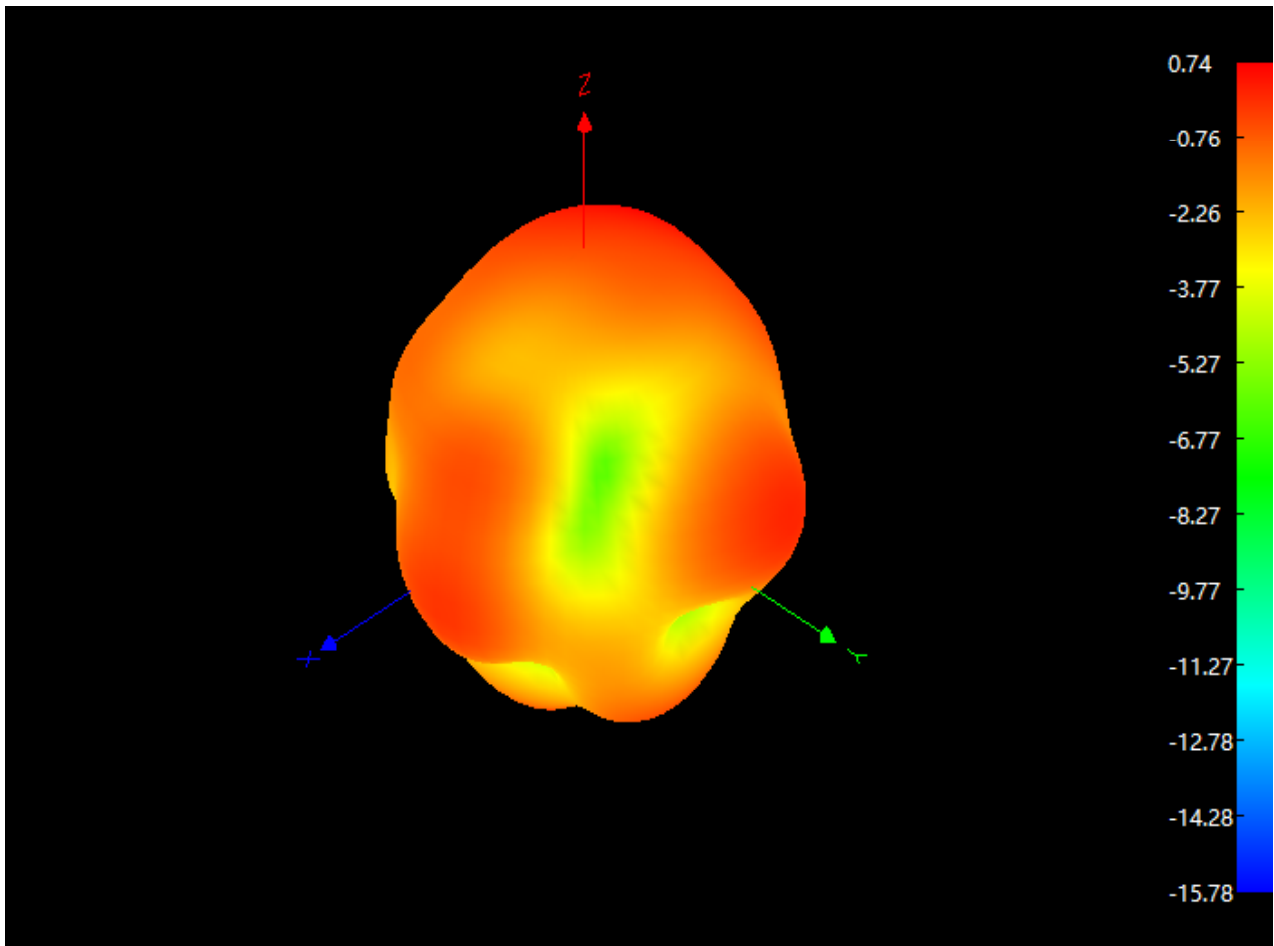



Device



*WiFi
Antenna*





WIFI Antenna

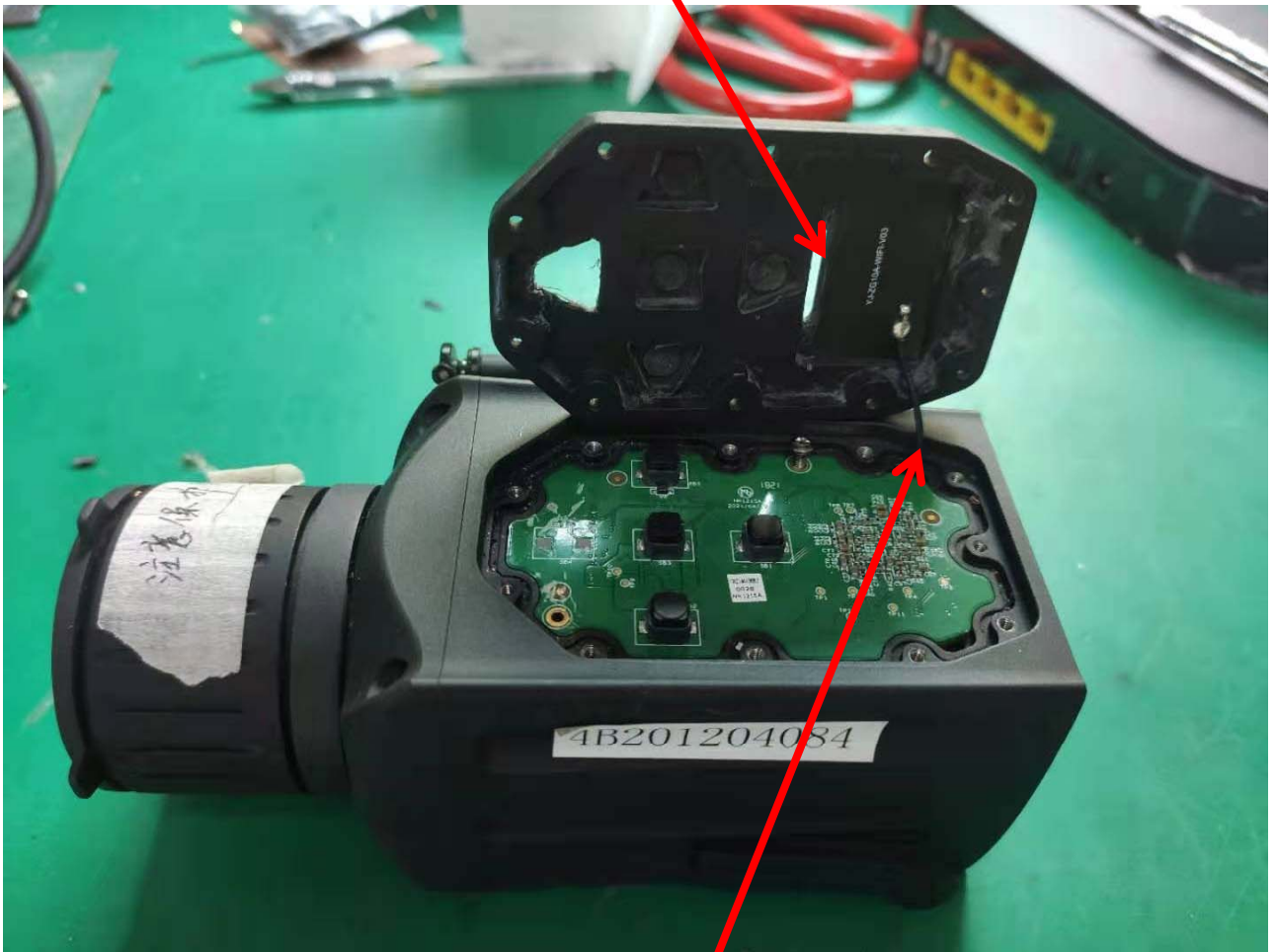

Material safety data sheet

Article and manufacturer informatio

Item name :KTM-150F WM
Ohter name: NONE
Recommended use: heat hardening printing ink
Name of manufacturer or supplier: supplier - keyway Technology Co., Ltd Manufacturer - kaiyao Technology Co., Ltd
Address of manufacturer or supplier: supplier - No.18, Lane 646, Boai street, Zhubei City, Xinzhu County Factory - No.18, Lane 646, Boai street, Zhubei City, Xinzhu County
Emergency contact: (03) 555-1822 Fax: (03) 553-1338

Hazard identification data

Hazard classification: flammable liquid, fire hazard Category 3, acute toxicity category 5.
Label content: flammable mixed solvent

Symbols: warning:
Hazard warning message: flammable substances, may be harmful if inhaled.
Hazard prevention measures: tightly cover the container; keep away from the ignition source - no smoking; place the container in a well ventilated place; take off the clothes as soon as they are polluted; wear eye mask / face shield; do not eat or drink when using, and avoid release to the environment
Other hazards:

Component identification data

INGREDIENTS	% by Wt	CAS No.
Polyester resin (polymer)	20~25%	28064-14-4
Mixed solvent	20~25 %	106-65-0 ; 1119-40-0 ; 627-93-0
Titanium dioxide	30~35%	13463-67-7
Filler	10~15 %	14807-96-6
Hexamethylene diisocyanate refers to oligomer	5~10 %	21093-51-6
Butyl acetate	1~5 %	627-93-0

First aid measures

First aid methods of different exposure routes:
Inhalation:1. remove the patient to fresh air immediately. It can only cause nose irritation and may be harmful to people. Skin contact: 1. Immediately wash with water.
Eye contact: 1. Immediately open the eyelids and wash them with mild water.
Ingestion:
Most important symptoms:
Protection for first aid personnel: wear protective gloves to avoid contact with pollutants.
Tips for doctors:.

Fire fighting measures

Suitable extinguishing agent: dry powder

Special hazards that may be encountered during fire fighting:

Special fire fighting procedures: 1. Remove the container from the fire site and put out the fire in the upwind.

2. Stop leakage without endangering personnel safety.

3. If the leakage cannot be stopped and the surrounding area is empty, the fire will burn out.

Special protective equipment for firefighters: Firefighters must wear air breathing apparatus, fire clothing and protective gloves.

Leakage treatment method

Personal precautions: 1. Restrict personnel access until the overflow area is completely clean.

2. It is determined that the trained personnel are responsible for the cleaning work.

3. Wear appropriate personal protective equipment.

Environmental precautions:

1. Ventilate the area.

2. Extinguish or remove all sources of ignition.

3. Report to relevant units of safety, health and environmental protection of the government.

Cleaning method: 1. Do not touch the leakage. 2. Avoid discharging into sewer or other confined space. 3. Try to prevent or reduce the leakage under the condition of safety permission. 4. Use sand, soil or other absorbing substances that do not react with leakage substances to enclose the leakage. 5. In case of a small amount of leakage, absorb it with absorbent that will not react with the leakage. Contaminated absorbents and spills are equally hazardous and should be placed in properly capped and labeled containers. Flush the spill area with water. 6. In case of a large number of spills, contact the fire department, emergency treatment unit and supplier for assistance.

Safe handling and storage methods:

Without special measures, it is not inflammable and explosive.

Storage: no corrosive container, no reactivity, low flammability, non flammable.

Exposure precautions

Engineering control: local exhaust device or integral air exchange device.

Control parameters: eight hour daily average allowable concentration / short time

average allowable concentration / maximum allowable concentration:

Personal protective equipment: respiratory protection:

Hand protection: impervious gloves, butyl rubber recommended, Teflon, 4h, barricale, chemrel

Eye protection: 1. Goggles (minimum 8 inches). 2. splash proof safety goggles. 3. Do not wear contact lenses. Skin and body protection: chemical protective clothing.

Physical and chemical properties

Material state: viscous paste liquid shape: paste liquid

Color: smell: Fragrance

PH value: slightly acidic boiling point / melting point range: OC /---

Decomposition temperature: flash point not measured:

Test method: open cup and close cup

Autoignition temperature: explosion limit: LEL: uel:

Vapor pressure: vapor density: > 1 (air 1)/

Specific gravity: 1.2 ~ 1.4 (25 / 25 °C) for water solubility:

Stability and reactivity

Stability: under normal conditions
Possible hazardous reactions under special conditions:
Conditions to avoid:
Substances to be avoided: acids.
Hazardous decomposition:

Toxicity data

Exposure route: skin contact, eye contact, ingestion
Symptoms: eye damage
Acute toxicity: inhalation:
Skin: causes mild irritation. Eyes: cause mild irritation. Ingestion:
LD50 (test animal, absorption pathway) local effect:---
Sensitization:---
Chronic toxicity or long-term toxicity:
Special effect:.

Ecological data

Ecotoxicity:
Durability and degradability:
Bioaccumulation:
Mobility in soil:
Other adverse effects:

Waste disposal method

Waste disposal method:
1. Handle according to the current laws and regulations.
Consider sanitary burying or burning in a qualified solvent burning tower.

Delivery information

UN No:
UN transport Name:
Transportation hazard classification:
Packing category:
Marine pollutants (yes / no):
Special delivery methods and precautions:-

Other information

References: None
Prepared by: kaiyao Technology Co., Ltd. / No.18, Lane 646, Boai street, Zhubei City, Xinzhu County/ Tel:03-5551822 / Fax:03-5531338
Prepared by: Xie Jinquan
Prepared on: August 15, 2014
Note: the above information and data are for reference only. The user shall determine the feasibility of the application according to the application requirements.

Material safety data sheet

一、Goods and manufacturer information

Item name: Halogen-free polyimide copper foil substrate(Halogen-free PI -CCL)
Item number: SHIS or SHID
Name of the manufacturer or supplier / Address / Telephone/Portraiture: Suzhou Serengeti Electronic Material Co., Ltd. /NO. 168 north Taiping road, Taicang city , Jiangsu Province, China/0512-5337 8333/0512-5337 8355
Emergency contact number/Phototelephony : 0512-5337 8333/0512-5337 8355

二、Component identification data

Pure substance :

Chinese and English names: 1. Halogen-free epoxy resin adhesive 2. Polyimide film 3. 3. Copper foil
Synonymous name: -
Chemical Abstracts Agency Registration Number(CAS No.): 1. (Halogen-free epoxy resin adhesive) 24969-06-0 25% ~ 41.2% 2. (Polyphenylene amine membrane) 25038-81-7 17.4% ~ 39.6% 3. (Copper foil) 7440-50-8 28.7% ~ 48%
Hazardous substance composition(percentage composition): < 15(Halogen-free epoxy resin adhesive)

三、Hazard identification data

Most important harm and effect	Health hazard effect: No harm to the human body.
	Environment effects: -
	Physical and chemical harm: -
	Special harm: -
Cardinal symptom: -	
Hazardous classification of articles: -	

四、Emergency treatment

First aid methods for different ways of exposure: Inhalation: There is no way to inhale the film. Skin contact: No stimulation. Eye contact: No volatiles are allowed to touch. Ingestion: There is no possible way for the film.
Most important symptoms and harmful effects: -
Protection of first aid personnel: -
Tips for doctors: -

五、Fire extinguishing measures

Applicable fire-extinguishing agent: Use a fire extinguishing agent suitable for isolating the fire site.
Special hazards that may be encountered at the time of fire-fighting: Inhalation of high-temperature pyrolysis substances.
Special fire-fighting program: -
Special protective equipment for firefighters: Wear air respirator and

protective gloves and fire-fighting clothes.

六、Emergency strain of leakage

Individual considerations: Use of personal protective equipment.

Environmental consideration: -

Cleaning method: -

七、Safety disposal and storage method

Handle: When operating, isolate from food and beverage.

Lay in: Store in a cool, dry and well-ventilated place.

八、Exposure prevention measures

Engineering control: -

Controlling parameter:

Average allowable concentration of eight hours per day/Short time average allowable concentration/Maximum allowable concentration: -

Biological index: -

Personal protective equipment:

Respiratory protection : A dust-proof mask.

Hand protection : Gloves.

Eye protection: Safety glasses.

Skin and body protection: -。

九、Physical and chemical properties

Material state:	Solid body	Form:	Membrane shape
Pigment:	Light brown ~ Dark brown(PI side)	Smell:	not have
PH value :	N/A	Boiling point/Boiling spread :	N/A
Decomposition temperature :	N/A	Flash point :	N/A test method : Open cup Closed cup
Autogenous ignition temperature :	N/A	Explosion limit :	N/A
Vapour pressure:	N/A	Vapour density :	N/A

十、Stability and reactivity:

Stability:	Stable under normal condition
Possible hazardous reactions in special conditions:	-
The situation to be avoided:	-
Substance to be avoided:	-
Hazardous decomposition products:	High thermal decomposition to produce nitrogen, phosphorus oxidation gas.

十一、Toxic data

Acute toxicity:	N/A
Local effect :	N/A
Sensitivity:	N/A

Chronic or long-term toxicity:	N/A
Special effects :	N/A

十二、Ecological data

Possible environmental impact/Environmental flow cloth:	-
---	---

十三、Disposal method

Handle according to local environmental laws and regulations.

十四、Transport information

International shipping regulations:	Not available for IATA, ICAO. (Non-dangerous goods)
UN number :	--
Domestic transportation regulations:	--
Special delivery methods and matters needing attention:	--

十五、Regulatory data

Applicable regulations:	Applicable to RoHS, GP, WEEE.
-------------------------	-------------------------------

十六、Other data

Rdocumentation :	--		
Tabulating unit:	Name:	Suzhou Serengeti Electronic Material Co., Ltd.	
	Address/Telephone:	NO. 168 north Taiping road, Taicang city , Jiangsu Province/ 0512-5337 8333	
Lister:	Professional ranks and titles : Department Manager	Name: Huang long	
Tabulation date:	16 February, 2019		
Remarks:	The symbol "--" in the above data indicates that there is no relevant information at present. All data and data are used for reference only. Users should judge their availability according to the application requirements.		

Material Safety Data Sheet

ITEM : PSM-800@ /SMH-800

Identity (Trade Name As Used On Label)

SECTION 1 IDENTIFICATION

Manufacturer

UNIRES CHEMICAL INDUSTRIAL CO.,LTD.

Address

22CHING CHIAN 4thRD.KUANYIN INDUSTRIAL

DISTRICT TAOYUAN HSIEN TAIWAN

Phone Number (For Information)

886-3-4836651 (fax)886-3-4837487

Emergency Phone Number

Telex * **886-3-4836651**

MSDS Number* **20110701AAA**

CAS Number*

07/01/2011

Data Prepared

HUANG CHIN HUAI

Prepared By*

Note: Blank spaces are not permitted. If any item is not applicable, or no information is available, the space must be marked to indicate that.

SECTION 2 COMPOSITION/INFORMATION ON INGREDIENTS

INGREDIENTS	CAS No.	CONTENTS(%)	OSHA (PEL)	ACGIH (TLV)
Heavy aromtic naphtha(petroleum)	64742-94-5	<12%	N.D.	N.D.
Epoxy-Acrylic derivative	Trade secret	<48%	N.D.	N.D.
Barium sulfate	7727-43-7	<20%	dust 15mg/m3	10mg/m3
Silica, amorphous, fused	7631-86-9	<8%	N.D.	dustTLV10mg/m3
Dipropylene glycol methyl ether	34590-94-8	<12%	100ppm	200ppm

SECTION 3 HAZARDS IDENTIFICATION

INHALATION : Highly concentrated vapor irritates nose, throat ant and lungs. May cause headache and dizziness.
EYE CONTACT : Slight irritation
SKIN CONTACT : Slight irritation
INGESTION : Harmful, if swallowed.

SECTION 4 FIRST AID MEASURES

SKIN CONTACT : Wash with plenty of water using a soap. Do not use organic solvents.
EYE CONTACT : Rinse immediately with clean water for at least 15 minutes. If irritation persists, seek medical attention
INHALATION : Immediately carry the victim to a place where fresh air is available. If irritation persists, treat with oxygen and seek medical attention.
INGESTION :obtain medical advice immediately. It is not recommended that vomiting be induced except on medical advice

SECTION 5**FIRE-FIGHTING MEASURES**

SUITABLE EXTINGUISHING MEDIA	: Carbon dioxide, foam, powder.
UNSUITABLE EXTINGUISHING MEDIA	: water spray and water jet.
EXPOSURE HAZARDS	: Burning may release oxides of carbon, nitrogen, sulfur and other toxic gases or vapors. Do not release chemically contaminated water into drains or surface waters, and soil according to local regulations.
PROTECTIVE EQUIPMENT	: Use full protective clothing and self-contained breathing apparatus.
FIR FIREFIGHTERS MEASURES	: promptly move transferable containers to another safety area .Check the speed of fire. Extinguish the fire with suitable extinguisher from the windward side

SECTION 6**ACCTDENTAL RELEASE MEASURES**

PERSONAL PRECAUTION	: Avoid ignition sources. Avoid contact with skin, eyes and clothing. Avoid inhaling vapor.
ENVIRINMENTAL PRECAUTIONS	: Prevent contamination of soil, drains and surface waters
METHODS FOR CLEANING	: Scoop up or absorb into combustible material, wipe out a stain in use organic solvents. Dispose in accordance with local regulations.

SECTION 7**HANDLING AND STORAGE**

HANDLTNG	: Handle with care. Avoid ignition sources. Ensure good ventilation and local exhaust. Do not smoke at the workplace
STORAGE	: Store in the original sealed container at less than 20°C.Avoid direct exposure to UV and sunlights.

SECTION 8**EXPOSURE CONTROLS/PERSINAL PROTECTION**

People who know they are chemically sensitive, should avoid contact with this product.

TECHNICAL PROTECTIVE MEASURES	: No special safety measures required.
EXPOSURE CONTROL LIMITS	: (see PEL and TLV values shown in shown in section 2)
RESPIRATORY PROTECTION	: Wear suitable mask to avoid inhalation of vapor.
HAND PROTECTION	: wear chemical resistant gloves.
EYE PROTECTION	: wear safety glasses.
SKIN PROTECTION	: wear suitable protective working cloths.

SECTION 9**PHYSICAL AND CHEMICAL PROPERTIES**

BOILING	: *156°C(760mmHg)	COLOR	: black
FLASH	: 75.0°C	FORM	: Paste
VAPOR PRESSURE	: * 2.00mmHg(40°C)	VAPOR DENSITY	: *6.08(Air=1)
SOLUBILITY IN WATER	: * <10.7wt%	ODOR	: Mild odor
		SPECIFIC GRAVITY	: 1.18

*Data of the organic solvents or monomers contained in this product is product is quoted.

SECTION 10	STABILITY AND REACTIVITY
-------------------	---------------------------------

STABILITY : Stable
CONDITIONS TO AVOID : Heat and sunlight.
MATERIALS TO AVOID : Strong acids, strong bases, peroxides and strong oxidizing agents.
HAZARDOUS DECOMPOSITION PRODUCTS : Burning may release oxides of carbon, nitrogen, sulfur and other toxic gases or vapors.

SECTION 11	TOXICOLGICAL INFORMATION
-------------------	---------------------------------

PRIMARY ROUTE(S) OF ENTRY

DERMAL INHALATION INGESTION

TOXICITY STUDIES : Toxicity studies have not been carried out in this product. Toxicity information available for the ingredients listed in section 2 is given below.

HEALTH HAZARDS

ACUTE INGESTION TOXICITY : N.E.
ACUTE SKIN IRRITATION : Slightly irritant
MUTAGENICITY : NONE

CARCINOGENICITY

NTP IARC OSHA NOT LISTED

SYMPTOMS OF OVER EXPOSURE

INHALATION : Slight irritation to respiratory tract. Highly concentrated vapor may cause headaches, and nausea.
EYES : Slight irritation
SKIN : Slight irritation
INGESTION : Expected to have a low order of toxicity.

SEVTION 12	ECOLOGICAL INFORMATION
-------------------	-------------------------------

ACUTE FISH TOXICITY : Ecological data are not available
BIODEGRADABILTY : No data available.

SEVTION 13	DISPOSAL CONSIDERATIONS
-------------------	--------------------------------

Incineration or landfill in accordance with local regulations.

SEVTION 14	TRANSPORT INFORMATION
-------------------	------------------------------

ADR : Inflammable liquid
IMDG-CODE : Free
IATA : Free
US DOT : Combustible liquid

UN : Free
FLASH POINT : 75.0°C

SECTION 15	REGULATORY INFORMATION
-------------------	-------------------------------

EEC LABELING : Harmful

RISK PHRASES : Harmful : may cause lung damage if swallowed. Harmful to aquatic organisms, may cause long-term adverse effects in the aquatic environment.

SAFETY PHRASES : Avoid contact with skin.
: Do not breathe vapor.
: If swallowed, do not induce vomiting :seek medical advice immediately and show this container or label.
: Avoid release to the environment. Refer to special instructions/Safety data sheets.

SECTION 16	OTHER INFORMATION
-------------------	--------------------------

This product should be stored, handled and used in accordance with good industrial hygiene practices and in conformity with any legal regulation. The information contained herein is based on the present state of our knowledge and is intended to describe our products from the point of view of view of safety requirements. It should not therefore be construed as guaranteeing specific properties.

It may not be valid for this material, if used in combination with any other materials.

MATERIAL SAFETY DATA SHEET (MSDS)

Issued: Dec 20, 2007

Revised: Dec 20, 2007

File No. 2302

1. CHEMICAL PRODUCT & COMPANY IDENTIFICATION

CHEMICAL PRODUCT NAME : DURANEX XFR4840
NAME OF COMPANY : WinTech Polymer Ltd.
SECTION IN CHARGE : Quality Assurance Dept.
ADDRESS : 2-18-1 Konan, Minato-ku, Tokyo,108-8280 Japan
TELEPHONE NUMBER : 03-6711-8605
FACSIMILE NUMBER : 03-6711-8616

2. COMPOSITION/INFORMATION ON INGREDIENTS

SUBSTANCE/PREPARATION : Preparation RATION
COMMON CHEMICAL NAME : Polybutyleneterephthalate
SYNONYMS : Polybutyleneterephthalate(PBT)
INGREDIENTS AND COMPOSITION : PBT \geq 80%, Phosphorus Flame retardant and others \leq 20%
CHEMICAL FORMULA : $\{ \text{C}_{10}\text{H}_{16}\text{O}_2 \}_n$
SERIAL No IN OFFICIAL GAZETTE : 7-1039 (base resin)
(Law Concerning Examination and Regulation of Manufacture, etc., of Chemical Substances)
CAS No : 2 4 9 6 8 - 1 2 - 5 (base resin)

3. HAZARDS IDENTIFICATION

PHYSICAL AND CHEMICAL HAZARDS : Not applicable
HUMAN HEALTH EFFECTS : Not applicable
ENVIRONMENTAL EFFECTS : Not applicable
PHYSICAL AND CHEMICAL HAZARDS : It is inflammable substance and combustible if an igniting source is existent. Neither dangerous reaction, fire nor explosion can be caused under normal conditions.
THE CLASSIFICATION : Not applicable

4. FIRST-AID MEASURES

INGESTION : Help to vomit as much as possible. If sick feeling continues, and ask a physician for advice.
INHALATION : When a gas generated from the molten polymer, especially fume generated during combustion or heat, has been inhaled, remove fresh air without delay and wait until the victim is recovered. If sick feeling continues, ask a physician for advice.
SKIN CONTACT : Cool the contacted skin with clean water without delay, if a contact with the polymer in a molten form. Do not force to remove the solid resin on the skin. If any burns are observed on the skin, ask a physician for advice.

EYE CONTACT : Cool and rinse the eye with clean water for at least 15 minutes when the eyes had contact with molten polymer. In case of wearing contact lenses,remove the lenses as soon as possible,and ask a physician for advice. When the eye had contact with the polymer in an ordinary solid form,rinse the eye with clean water without delay. If the discomfort persists,ask a physician for advice.

5. FIRE-FIGHTING MEASURES

EXTINGUISHING MEDIA : Water,form fire-extinguishing agent,powder fire-extinguishing agent,and carbon dioxide gas.

SPECIFIC METHODS : Extinguish the fire with water. A method of extinguishing an ordinary fire may be applied. Do not apply water directly to processing machines.

SPECIFIC HAZARDS : Incomplete combustion leads to generation of toxic gases such as carbon monoxide or tetrahydrofuran,in addition to carbonic acid gas and water.

SPECIAL EQUIPMENT FOR THE PROTECTION OF FIREFIGHTERS : In case the fire gained force,use a gas mask or other protective equipment.

6. ACCIDENTAL LEAKAGE MEASURES

PERSONAL PRECAUTIONS : When pellets were spilled on the road or floor,wipe them off with a besom or cleaner not to cause slipping.

ENVIRONMENTAL PRECAUTION : Handle the spillage in accordance with provisions given in the "Resin pellet spillage preventive manual",in order to prevent intakes by marine animals and birds.

7. HANDLING AND STORAGE

HANDLING : This resin in a pellet form will neither ignite nor explode at room temperatures.

HANDLING 2 : For molding work,effective means for local exhaust are required to discharge gases generated by melt processing.

HANDLING 3 : Avoid inhaling of gases generated in moulding work. Do not directly touch resin of high temperature.

HANDLING 4 : Avoid retaining hot resin in the processing machines for many hours.

HANDLING 5 : This pellets spilled on the floor are likely to cause slipping. Remove such spillage at any times.

STORAGE : Keep the substance away from any fire or heat sources for the sake of safe storage.

RECOMMENDED PACKAGING MATERIALS : No information.

8. EXPOSURE CONTROL / PERSONAL PROTECTION

CONTROL CONCENTRATION : None at present

PERMISSIBLE CONCENTRATION : OSHA PEL/1985
Max. permissible concentration of inactive powder 15mg/m³
- ditto - (Aspiration) 5 mg/m³
ACGIH TLV/1992 1993
Exposure limit of the powder TWA 10 mg/m³

ENGINEERING MEASURE : When handling dust: Use totally enclosed containers resisting dust explosion.
When heat melted in molding: Effective local ventilation must be provided.

PERSONAL PROTECTIVE EQUIPMENT	:	
RESPIRATORY PROTECTION	:	Wear a dust-proof mask.
EYE PROTECTION	:	Wear protective glasses or goggles.
HAND PROTECTION	:	Wear heat-resisting gloves against burns, when handling molten polymer.
SKIN & BODY PROTECTION	:	Wear long sleeve clothes against burns, when handling molten polymer.

9. PHYSICAL AND CHEMICAL PROPERTIES

APPEARANCE etc.	:	Pellet
BOILING POINT	:	Not applicable
VAPOUR PRESSURE	:	Not applicable
VOLATILITY	:	Not applicable
SUBLIMATION	:	None
MELTING POINT	:	228°C
DENSITY	:	1.32g/cm ³
SOLUBILITY	:	Insoluble in water
FLASH POINT	:	300°C or higher
IGNITION POINT	:	300°C or higher
EXPLOSION PROPERTY	:	Not applicable
INFLAMMABILITY	:	None
REACTIVITY WITH WATER	:	None
OXIDIZABILITY	:	None
SELF-REACTIVITY	:	None
DUST EXPLOSIVENESS	:	Upper explosion limit : Not applicable. Lower explosion limit : 35g/m ³

10. STABILITY AND REACTIVITY

STABILITY AND REACTIVITY	:	Stable for normal storage or handling.
--------------------------	---	--

11. TOXICOLOGICAL INFORMATION

SKIN CORROSIVE PROPERTIES	:	No finding.
SENSITIZING & IRRITANT EFFECTS	:	Gas generated in drying or melting is irritating eyes and skins.
ACUTE TOXICITY (INCLUDING LD50)	:	No finding.
SUBACUTE TOXICITY	:	No finding.
CHRONIC TOXICITY	:	No finding.

CARCINOGENECITY : No finding.

MUTAGENECITY(Mi : No finding.
cro
organisms,chromoso
mal aberration)

REPRODUCTIVE : No finding.
TOXICITY

TERATOGENICITY : No finding.

OTHERS(Including : No finding in this report means that there will be no hazard in
generation of general,but no proving data available at the time of reporting.
hazardous gases by
reaction with
water,for ezample)

OTHER CAUTIONS : With regard to dust,the maximum permissible concentration and limits
are fixed by OSHA and ACGIH.

12. ECOLOGICAL INFORMATION

BIODEGRADABILITY : No finding.

BIOACCUMULATION : No finding.

FISH TOXICITY : No finding.

13. DISPOSAL CONSIDERATION

WASTE FROM : This is designated as waste plastics among industrial wastes by the
RESIDUES Wastes Disposal Law. Disposal waste pellets through licensed wastes
handlers or local autonomous bodies if they are handling wastes
disposal.

WASTE FROM : When disposed by incineration,use the well controlled incinerators in
RESIDUES 2 accordance with the Wastes Disposal Law,Air Pollution Control Law and
Water Pollution Prevention Law.

14. TRANSPORT CONSIDERATION

UN : Not applicable
CLASSIFICATION
NUMBER

OTHER CAUSIONS : Handle with care so as not to give damages to containers or not to be
subjected to wetting.

OTHER CAUSIONS : Secure the containers firmly so as not to cause collapsing.
2

15. REGULATORY INFORMATION

WASTE DISPOSAL : Waste plastics among industrial wastes.
LAW

16. OTHER INFORMATION

HANDLING OF THE : This MSDS is the English version translated from the Japanese MSDS
DETAILS GIVEN which is prepared for domestic use.
ABOVE Details given above are based on references, information and data
available at this moment, but no warranty can be made on exactness of
these details. They are also prepared on the assumption that the
product will be handled in a normal way. For special handling, adequate
safety and environmental measures should be taken in respect to its
applications. Our products are not specifically intended for implants for
medical and dental applications, and therefore they are not
recommended for such applications.
"No finding" in this report means that there will be no hazard in general,
but no proving data is available at the time of reporting.

MATERIAL SAFETY DATA SHEET

MSDS FILE No. (KURAMI WORKS) : 05-1225

(based on Form OSHA-174)

IDENTITY (AS Used on Label and List)

Product Class : Phosphor Bronze Strip
 Trade Name : JIS H3130 C5210R (Equivalent to ASTM B103 C52100)
 CAS No. : Copper: 7440-50-8, Tin: 7440-31-5, Phosphor: 7723-14-0
 Chemical Composition

	Content(wt-%)	CAS No.
Tin(Sn)	7.0~9.0	7440-31-5
Phosphor(P)	0.03~0.35	7723-14-0
Copper(Cu)	Balance	7440-50-8
Sn+P+Cu	99.7 \leq	-

Section I

Manufacturer's Name NIKKO METAL MANUFACTURING CO., LTD. KURAMI WORKS	Date Prepared May 24th, 2005
Address 3 Kurami Samukawa-cho Kouza-gun Kanagawa prefecture 253-0101 JAPAN	Signature of Person in Charge <i>Chihiro Izumi</i> IZUMI, Chihiro Senior Technical Supervisor, Quality Assurance
Telephone Number for Information (Quality Assurance) +81-467-75-7285	Signature of Person Responsible <i>Hiroaki Watanabe</i>
Facsimile Number for Information (Quality Assurance) +81-467-74-6971	WATANABE, Hiroaki Manager, Quality Assurance Section

Section II Hazardous Ingredients / Identity Information

Hazardous Components (Specific Chemical Identity : Names OSHA PeI ACGIH TLV)

Nothing for ordinary service condition

Section III Physical / Chemical Characteristics

Boiling Point 2630 °C for Copper 2275 °C for Tin	Specific Gravity (H2O = 1) 8.80
Vapor Pressure (mmHg) N/A	Melting Point 1025 deg. centi. for C5210 Phosphor Bronze
Vapor Density (Air = 1) N/A	Evaporation Rate (Butyl Acetate = 1) N/A
Solubility in Water N/A	
Appearance and Odor Brown - Red (solid) : Odor - None	

Section IV Fire and Explosion Hazard Data

Flash Point (Method Used) N/A	Flammable Limits N/A	LEL N/A	UEL N/A
Extinguishing Media N/A (stable , nonflammable substance)			
Special Fire Fighting Procedures Not specified			
Unusual Fire and Explosion Hazards Metal products do not present fire or explosion hazards under normal conditions.			

Section V Reactivity Data

Stability	Unstable		Conditions to Avoid
	Stable	X	

Incompatibility (Materials to Avoid)

Nothing

Hazardous Decomposition or Byproducts

Nothing

Hazardous Polymerization	May Occur		Conditions to Avoid
	Will Not Occur	X	

Section VI Health Hazard Data

Route(s) of Entry :	Inhalation ?	Skin ?	Ingestion ?
	N/A	N/A	N/A

Health Hazardous (Acute and Chronic)

N/A

Carcinogenicity :	NTP ?	IARC Monographs ?	OSHA Regulated ?
	N/A	N/A	N/A

Signs and Symptoms of Exposure

N/A

Medical Conditions

Generally Aggravated by Exposure N/A

Emergency and First Aid Procedures

N/A

Section VII Precautions for State Handling and Use

Steps to Be Taken in Case Material Is Released or Spilled

N/A

Waste Disposal Method

Collect scrap for remelting.

Precautions to Be Taken in Handling and storing

For Handling

- Put safety gloves on to protect your hands from edges of coils which might cut your hands.
- Wear safety glasses when metal powders or chips are expected to be generated in the work.
- Put safety shoes on when handling heavy coils.

For Storing

- The environment of stocking area should be free from acid, alkali, chloride, sulfide and other corrosive chemicals to prevent from rusting or corrosion.

Other Precautions

No special requirements

Section VIII Control Measures

Respiratory Protection (Specify Type)

Wearing a mask be recommended in the work such as abrasion and buffing which generates metal powders or chips.

Ventilation	Local Exhaust	Special
	None	None
	Mechanical (General)	Other
	None	None

Protective Gloves

Put safety gloves on to protect your hands from edges of coils which might cut your hands.

Eye Protection

Wear safety glasses when metal powder is expected to be generated in the work.

Other Protective Clothing or Equipment

Put safety shoes on when handling heavy coils.

Work / Hygienic Practices

None

Influence to environments

Fish on toxicity : TLm 48 hr. on CuSO4

Salmogairdeneri : 0.038 ~ 0.8 ppm

Oryzias Latipes : 2.1 ~ 24ppm

Material Safety Data Sheet

1. Manufacturer

- Company HARADA Metal Industry Co., Ltd.
- Address 10-18 Sasamekitamati, Toda, Saitama 335-0033, Japan
TEL 048-422-1588
FAX 048-449-6303
- Counter The domestic business department business primary and second section
TEL 048-441-5115
FAX 048-444-9104
The domestic business department OSAKA service office
TEL 06-531-8094
FAX 06-531-8096
The domestic business department NAGOYA service office
TEL 052-821-9778
FAX 052-822-7500
The overseas business department export section
TEL 048-441-5115
FAX 048-444-9104
- Urgent place to contact
The quality assurance department
TEL 048-422-1588
FAX 048-449-6303

2. Products

- Phosphor bronze plates and strips for springs
- Phosphor bronze plates and strips

3. Specification of the material

- The division of mixture or single product : Single product
- The chemical name : Copper alloy
- Chemical composition and content rate(wt.%)

Element	Percent					CAS No.
	C5210	C5212	C5191	C5102	C5111	
Copper	rem.	rem.	rem.	rem.	rem.	7440-50-8
Tin	7.0~9.0	7.0~9.0	5.5~7.0	4.5~5.5	3.5~4.5	7440-31-5
Phosphorus	0.03~0.35	0.03~0.35	0.03~0.35	0.03~0.35	0.03~0.35	7723-14-0
Lead	0.05 max	0.05 max	0.05 max	0.05 max	0.05 max	7439-92-1
Iron	0.1 max	0.1 max	0.1 max	0.1 max	0.1 max	7439-89-6
Zinc	0.2 max	0.2 max	0.2 max	0.2 max	0.2 max	7440-66-6

4. Classification of harmfulness

- The name of classification : Not classified into the dangerous harmfulness material.
- The danger : No knowledge
- The harmfulness : No knowledge
- The effect for the environment : No knowledge

5. First aid

- Eyes : Flush the water. Consult the doctor, when the simulation of the eye continues.
- Skin : Flush the water.
- Inhalation : Consult the doctor, when it was large inhaled.

6. The treatment in the fire

- Nonflammable.

7. Leakage

- Not applied (because of solid)

8. Attention in handling and storage

- Stored at the ordinary—temperature and usual humidity.
- Prohibition of the rapid temperature and humidity change.

9. Treatment on the exposure prevention

- Standard control concentration : Not regulated.
- Allowable temperature : Not regulated.
- Facility countermeasure : The whole ventilation is desirable.
- Protector : For lung ,the wear of protection mask is desirable for the power handling.
For hand ,the wear of protective glove is desirable.
For eyes ,the wear of safety goggles is desirable for the power handling.
For body , the wear of protective clothing is desirable.

10. Physical and chemical characteristic

- Appearance and smell : The solid with the metallic luster. Odoless.
- Boiling point : The indistinctness.
- Solubility : Dissolves in the inorganic acid.

	C5210	C5212	C5191	C5102	C5111
Specific gravity	8.82	8.82	8.85	8.88	8.90
Melting point	1020°C	1020°C	1045°C	1050°C	1060°C

11. Information for danger

- Fire point : The indistinctness.
- Stability : Show the stability at room temperature and in the air.
- The situation to be avoided : —

12. Information for harmfulness

- The powder stimulates eyes , skin and bronchi.
- Produce the ulcer and the hepatic disorder rarely.

13. Information for environment

- No knowledge.

14. Attention for scrapping

- Possible to deal with ,as an industrial waste.

15. Attention for transportation

- No damage transportation is desirable.

16. Applying act

- —