

User Manual

Product Name: Bluetooth module

Model Name: DX-BT04-E

Manufacture: SHEN ZHEN DX-SMART TECHNOLOGY CO., LTD



Table Of Contents

1、 Overview.....	15
2、 Module default parameters.....	15
3、 Application area.....	16
4、 Power consumption parameters.....	17
5、 RF characteristics.....	17
6、 Transparent transmission parameters.....	17
7、 Module pin description and minimum circuit diagram	18
8、 Pin function description	18
9、 Other configuration.....	19
10、 Dimensions	19
11、 LAYOUT considerations.....	20
12、 AT COMMAND	21
12.1 Test Command	22
12.2 Software restart	22
12.3 Get The Software Version	22
12.4 Restore default settings	22
12.5 Query Module Bluetooth MAC.....	23
12.6 Set/Query Device Name	23
12.7 Set / Query-Pairing password	23
12.8 Set/Query - Serial Port Baud Rate.....	23
12.9 Settings\Query-SERVICE UUID	24
12.10 Settings\Query-NOTIFY UUID.....	24
12.11 Settings\Query-WRITE UUID.....	24
12.12 Settings\Query - Broadcast time interval.....	25
13、 Contact us	26



1、 Overview

DX-BT04-E Bluetooth module is specially built for intelligent wireless data transmission by ShenzhenDX-SMARTTechnology Co., Ltd. SPP + BLE dual-mode Bluetooth.

This module supports the UART interface and the SPP Bluetooth serial protocol. It has the advantages of low cost, small size, low power consumption, and high sensitivity of receiving and sending. It only needs to be equipped with a few peripheral components to achieve its powerful functions.

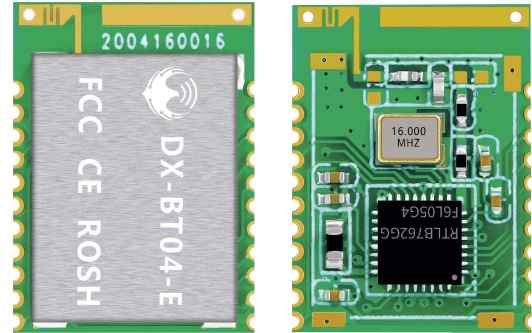

二、 Module default parameters

Bluetooth Protocol	Bluetooth Specification V3.0 SPP +V4.2 BLE
Working Frequency	2.4GHz ISM band
Communication Interface	UART
PowerSupply	MIN:1.8V - MAX:3.6V (Suggest 3.3V)
antenna	PCB onboard antenna
Communication distance	30-40M (Open and unobstructed environment)
Physical Dimension	16.1mm x 11.4mm x 2 mm
Physical Dimension	ROHS REACH FCC
Bluetooth Name	BT04-E(customizable)
Pairing code	1234 (SPP agreement is valid)
Serial Port Parameters	9600、8data bits、1 stop bit、No check、Noflow control
Service UUID	FFE0
Notify UUID	FFE1
Write UUID	FFE2
Storage temperature	MIN:-40℃ - MAX:+125℃
Work temperature	MIN:-20℃ - MAX:+85℃
Customized requirements	If you have other special function requirements, youcan contact us tocustomize the module.



3. Application area:

The module is mainly used in the field of short-range wireless data transmission. It can be easily connected to the Bluetooth devices of mobile phones and PCs, avoiding the cumbersome cable connection, and can directly replace the serial cable.

- ※ Bluetooth wireless data transmission
- ※ Industrial remote control, telemetry
- ※ POS system
- ※ Traffic, alarm
- ※ Automated data acquisition system
- ※ Wireless data transmission; banking system
- ※ Wireless data collection
- ※ Building automation, security, computer room equipment wireless monitoring, access control system;
- ※ Smart home, industrial control;
- ※ medical instruments
- ※ Electronic scale
- ※ Bluetooth printer, meow machine
- ※ Bluetooth remote control toys
- ※ Automotive testing equipment
- ※ Car diagnostic system OBDII



4、Power consumption parameters:

DC-DC	Average Current	Unit
Discoverable	4	mA
Connected(BLE)	4	mA
Connected(SPP)	9	mA

5、RF characteristics

Rating	Value	Unit
Basic Rate Transmit power	0	dBm
Basic Rate Sensitivity	-90	dBm
BLE Transmit power	0	dBm
BLE Sensitivity	-93	dBm

6、transparent transmission parameters

BT04-E dual-mode SPP data throughput:

Android ->BT04-E -> UART	UART ->BT04-E -> Android	BAUD
12000 bytes/s	4500 bytes/s	115200

BT04-E dual-mode BLE data throughput:

IPhone ->BT04-E -> UART		UART ->BT04-E -> IPhone	
Baud rate	115200	Baud rate	115200
Connection interval(ms)	115200	Connection interval(ms)	15
APP packet size(bytes)	15	Serial packet size (bytes)	80
Send interval(ms)	80	Send interval(ms)	70
Throughput(bytes/s)	50	Throughput(bytes/s)	2500
Characteristic Write	Write without Response	Characteristic Write	Notify



7、Module pin description and minimum circuit diagram

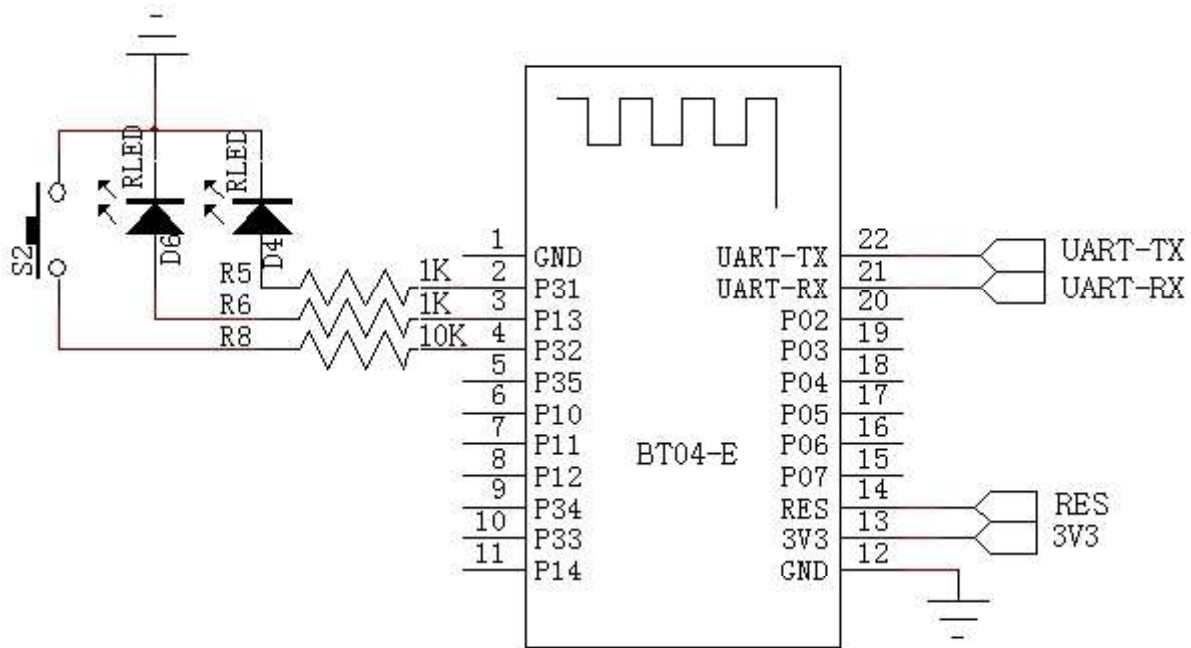

注意：该应用电路图为蓝牙串口电路，如需要其他应用方案，请联系我司

8、Pin function description:

管脚号	名称	类型	功能描述
1	GND	Land	Land
2	P31	output	Module disconnect indication port (see other Set up)
3	P13	output	Connection status indicator LED port (see other Set up)
4	KEY	Bidirectional	Disconnectable (200ms low pulse disconnect)
5	P35	Bidirectional	Programmable input and output port
6	P10	Bidirectional	Programmable input and output port
7	P11	Bidirectional	Programmable input and output port
8	P12	Bidirectional	Programmable input and output port
9	P34	Bidirectional	Programmable input and output port
10	P33	Bidirectional	Programmable input and output port
11	P14	Bidirectional	Programmable input and output port
12	GND	Land	Land
13	3.3V	power input	+3.3V power supply
14	RESET	CMOS input	Reset/Restart Key (Low level reset at least 200ms)



15	P07	Bidirectional	Programmable input and output port
16	P06	Bidirectional	Programmable input and output port
17	P05	Bidirectional	Programmable input and output port
18	P04	Bidirectional	Programmable input and output port
19	P03	Bidirectional	Programmable input and output port
20	P02	Bidirectional	Programmable input and output port
21	UART-RX	CMOS input	Serial port data input
22	UART-TX	CMOS output	Serial port data output

9、Other configuration

Status indicator LED: P13

It is used to indicate the status of the Bluetooth module. The flashing mode of the LED light corresponds to the status of the Bluetooth module. See the table below::

mode	LED display	Module status
Standby	Flashes slowly and evenly (500ms-on, 500ms-off)	Waiting for pairing
	Long bright	establish connection

Bluetooth module disconnect indication: P31

Used to indicate whether the Bluetooth module is connected, the connection status is high, and the other status is low.

10、Dimensions:

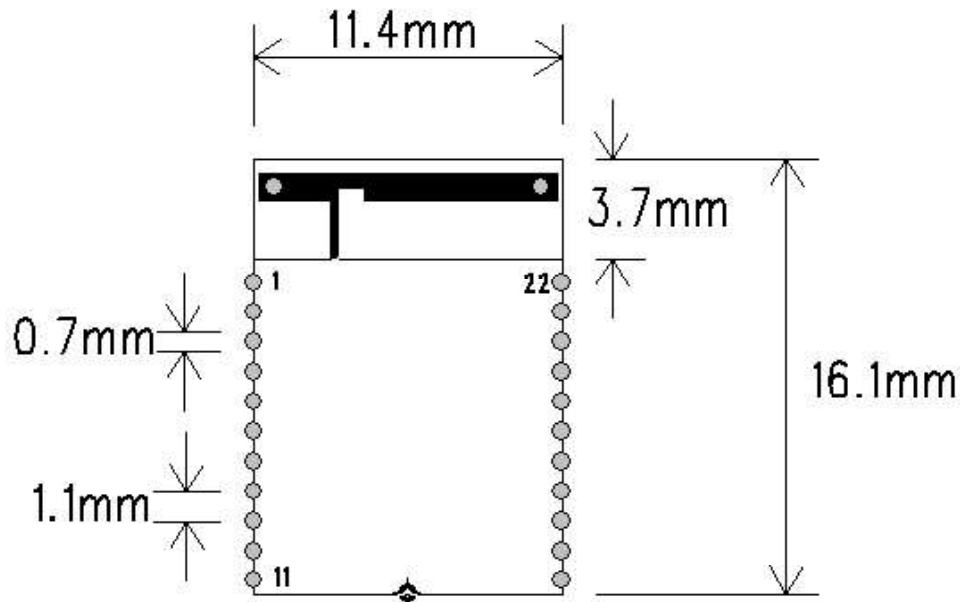

11、LAYOUT considerations

1. The serial port level of the DX-BT04-E Bluetooth module needs to be 3.3V. If it is



connected to a 5V level system, a level conversion chip needs to be added.

2. The Bluetooth signal is greatly affected by the surroundings. Obstacles such as trees, metals, walls, etc. will absorb or shield the Bluetooth signal to a certain extent, so it is recommended not to install it in a metal enclosure.

3. Since metal will weaken the antenna function, it is recommended not to lay the ground and wiring under the module antenna when giving the module Lay board, it is best to be hollowed out.

(Recommend)

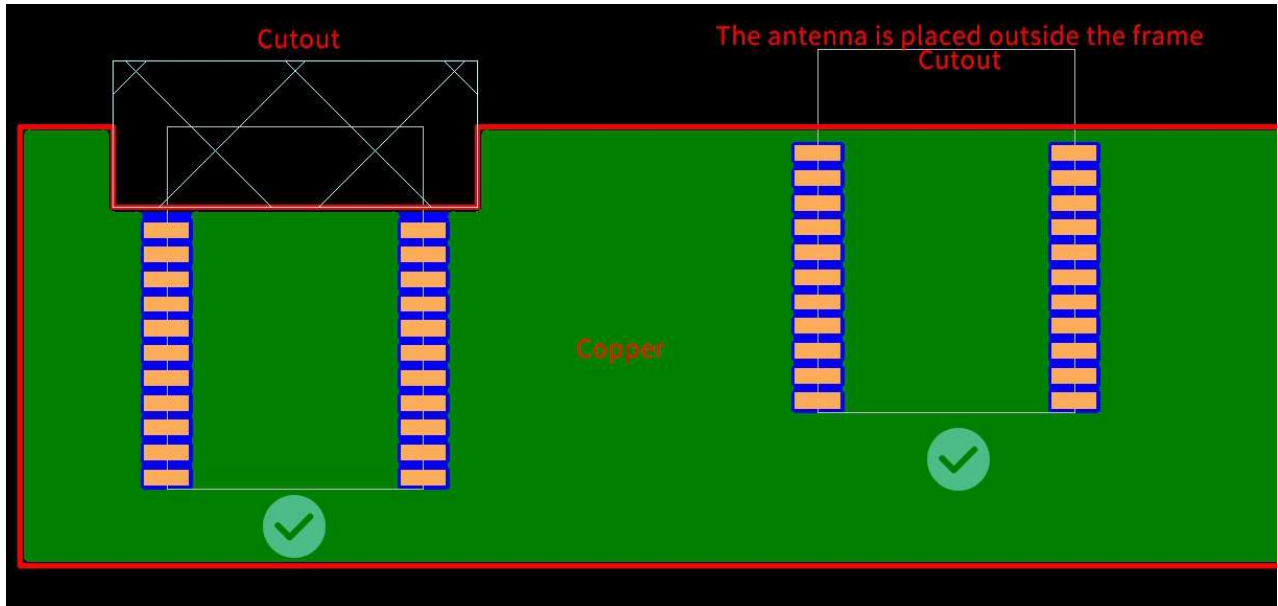

(Not recommend)

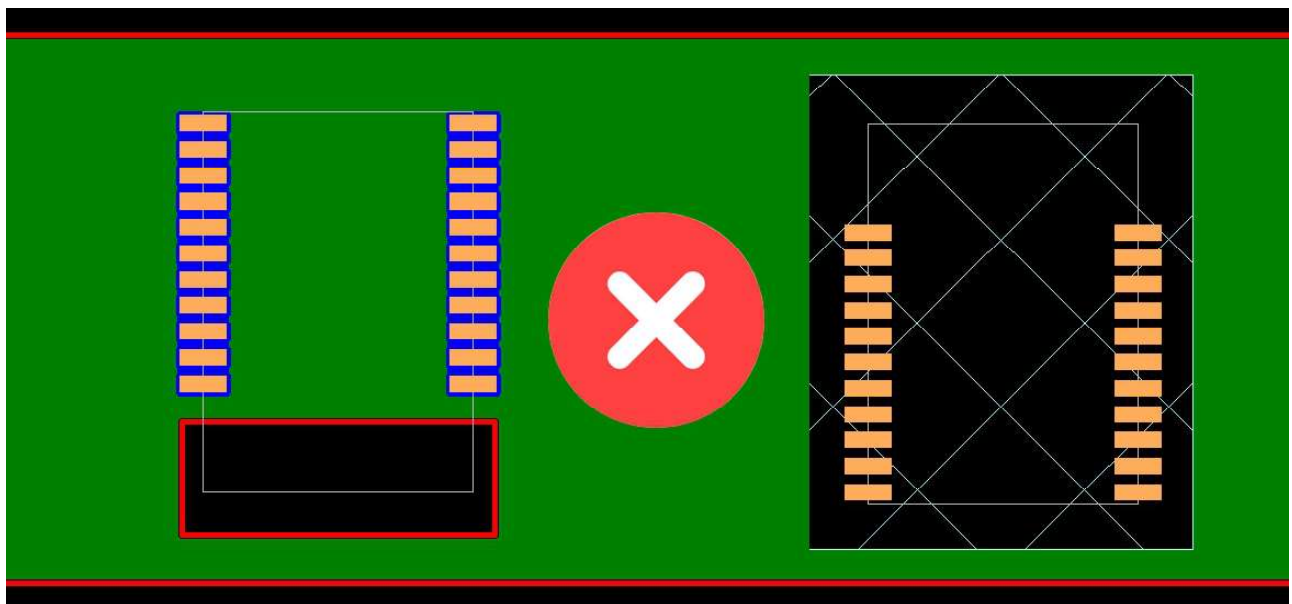

12、 AT COMMAND



Users can communicate with the DX-BT04-E Bluetooth module through the serial port. The serial port uses Tx and Rx signal lines

Baud rate support 2400, 4800, 9600, 19200, 38400, 57600, 115200bps

Serial port default baud rate 9600bps

Detailed instruction set description (AT mode when the module is not connected, and transparent transmission mode when connected)

DX-BT04-E Bluetooth serial port module command is Command command set.

(Note: When the module is powered on, if it is not paired, it is in AT mode. AT commands can only take effect when the module is not connected. Once the Bluetooth module is connected to the device, the Bluetooth module enters data transparent transmission mode.)

AT command format example (Figure 1 is AT test command, Figure 2 is to change the Bluetooth name to 1234):



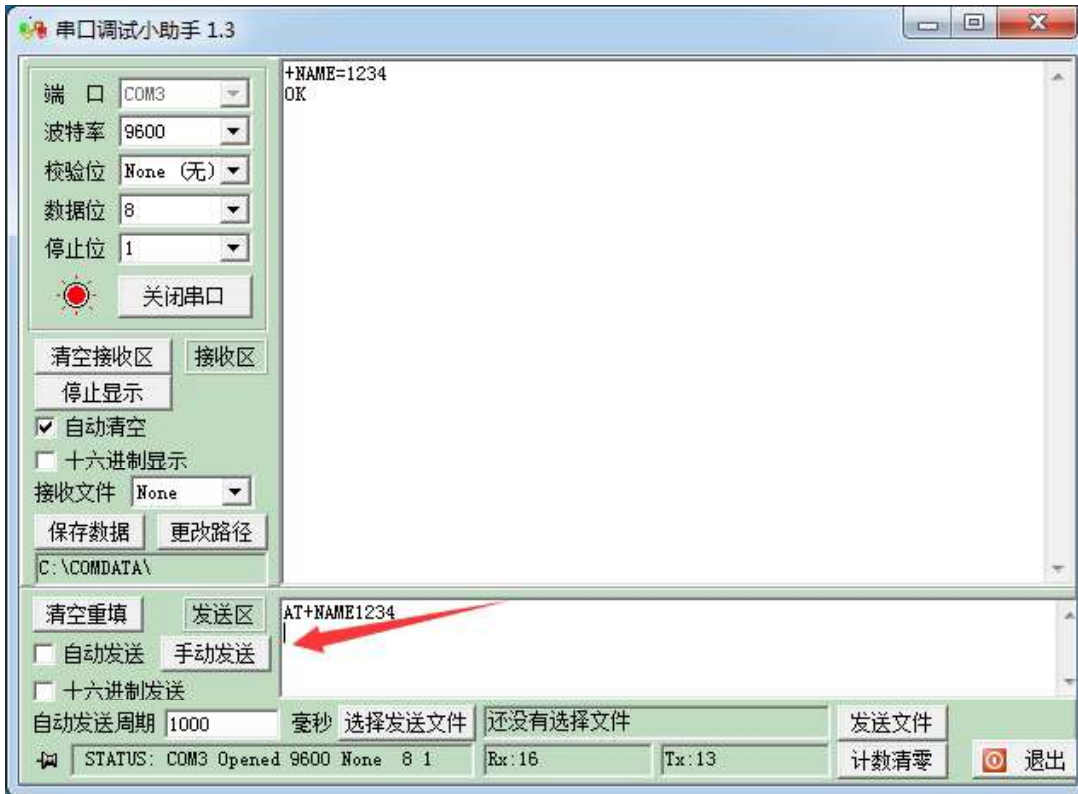

12.1、 Test Command:

Down command	response	parameter
AT	OK	no

12.2、 Software restart:

Down command	response	parameter
AT+RESET	OK	No

12.3、 Get The Software Version:

Down command	response	parameter
AT+VERSION	+VERSION=<Param> OK	Param: Software version number

Example:

Send: AT+VERSION\r\n

Return: +VERSION=2.0-20100601 OK

12.4、 Restore default settings:

Down command	response	parameter
AT+DEFAULT	OK	No



12.5、Query Module Bluetooth MAC:

Down command	response	parameter
AT+LADDR	+ LADDR =<Param>	Param:address code

Example:

Send: AT+LADDR\r\n

Return: +LADDR=11:22:33:44:55:66

11:22:33:44:55:66is the actual address code obtained from the query.

12.6、Set/Query Device Name:

Down command	response	parameter
AT+NAME<Param>	OK	
AT+NAME	1、 +NAME=<Param> OK——success 2、 FAIL——failure	Param: Bluetooth device name default name: “BT04-E”

Example: Modify the name of the Bluetooth device1234

Send: AT+NAME1234\r\n

Return: +NAME=1234

At this time, the Bluetooth name is changed to1234

Parameters can be saved after power-off.

12.7、Set/Query-Pairing password:

Down command	response	parameter
AT+PIN<Param>	OK	
AT+ PIN	+ PIN =<Param> OK	Param: Default name of the pairing code: “1234”

Example: Modify the
pairing code to 8888

Send: AT+PIN8888\r\n

Return: +PIN=8888

At this time, the Bluetooth pairing password is changed to 8888, and the module's default pairing password is 1234.

12.8、Set/Query - Serial Port Baud Rate:

Down command	response	parameter
AT+BAUD<Param>	OK	<Param>: Baudrate
	+BAUD=<Param> OK	2---2400 3---4800 4---9600



AT+BAUD		5---19200 6---38400 7---57600 8---115200
		default: 4---9600

Example: Modify the baud rate to 38400

Send: AT+BAUD6

Return: +BAUD=6

At this time the baud rate is 38400

Note: After the baud rate is changed, if it is not the default 9600, the parameter setting or data communication is required to use the set baud rate

12.9、Settings\Query-SERVICE UUID default:FFE0

Down command	response	parameter
(Inquire) AT+UUID	+UUID=<Param>	Param: UUID号
(Set up) AT+UUID<Param>	+ UUID =<Param> OK	

Example: modify/InquireSERVICE UUID

Send: AT+UUID\r\n

Return:+UUID=FFE0

Send: AT+UUIDFFE1\r\n

Return: +UUID=FFE1\r\n OK

Note: After the UUID is set, the setting will take effect after a reset operation.

12.10、Inquire/Set up— NOTIFY UUID\ READ UUID default:FFE1

Down command	response	parameter
(Inquire) AT+CHAR	+CHAR=<Param>	Param: UUID号
(Set up) AT+CHAR<Param>	+ CHAR =<Param> OK	

Example: modify/Inquire NOTIFY UUID\ READ UUID

Send: AT+CHAR\r\n

Return: +CHAR=FFE0

Send: AT+CHARFFE1\r\n

Return: +CHAR=FFE1\r\n OK

Note: After the UUID is set, the setting will take effect after a reset operation.

12.11、Inquire/Set up— WRITE UUID default: FFE2

Down command	response	parameter
(Inquire) AT+WRITE	+WRITE=<Param>	Param: UUID号
(Set up) AT+WRITE<Param>	+ WRITE =<Param> OK	



Example: Modify / Query write to WRITE UUID

Send: AT+WRITE\r\n

Return: +WRITE=FFE2

Send: AT+WRITEFFE1\r\n

Return: +WRITE=FFE1\r\n OK

Note: After the UUID is set, the setting will take effect after a reset operation.

12.12. Inquire/Set up—Broadcast time interval default: 0

Down command	response	parameter
(Inquire) AT+ADVI\r\n (Set up) AT+ADVI<Param>\r\n	+ADVI=<Param>	Param: Broadcast interval 0—100ms 1—152.5ms 2—211.25ms 3—318.75ms 4—417.5ms 5—546.25ms 6—760ms 7—852.5ms 8—1022.5ms 9—1285ms A—2000ms B—3000ms C—4000ms D—5000ms E—6000ms F—7000ms default setting: 0

Example: modify / query broadcast interval

Send: AT+ADVI\r\n

Return: +AVDI=0

Send: AT+AVDI1\r\n

Return: +AVDI=1 OK

(Corresponds to 152.5ms)

Note: After the broadcast interval is set, it needs to be reset to take effect.



13、Contact us

ShenZhenDX-SMARTTechnology Co., Ltd.

Address: 511, Building C, Yuxing Technology Park, Yuxing Chuanggu, Bao'an District, Shenzhen, China

Tel: 0755-2997 8125

Fax: 0755-2997 8369

Website: <http://www.szdx-smart.com/>

FCC Statement

FCC standards: FCC CFR Title 47 Part 15 Subpart C Section 15.247

Integral antenna with antenna gain 0dBi

This device complies with part 15 of the FCC Rules. Operation is subject to the following two conditions: (1) This device may not cause harmful interference, and (2) this device must accept any interference received, including interference that may cause undesired operation.

Any Changes or modifications not expressly approved by the party responsible for compliance could void the user's authority to operate the equipment.

Note: This equipment has been tested and found to comply with the limits for a Class B digital device, pursuant to part 15 of the FCC Rules. These limits are designed to provide reasonable protection against harmful interference in a residential installation. This equipment generates, uses and can radiate radio frequency energy and, if not installed and used in accordance with the instructions, may cause harmful interference to radio communications. However, there is no guarantee that interference will not occur in a particular installation. If this equipment does cause harmful interference to radio or television reception, which can be determined by turning the equipment off and on, the user is encouraged to try to correct the interference by one or more of the following measures:

- Reorient or relocate the receiving antenna.
- Increase the separation between the equipment and receiver.
- Connect the equipment into an outlet on a circuit different from that to which the receiver is connected.
- Consult the dealer or an experienced radio/TV technician for help.

FCC Radiation Exposure Statement

This modular complies with FCC RF radiation exposure limits set forth for an uncontrolled environment.

If the FCC identification number is not visible when the module is installed inside another device, then the outside of the device into which the module is installed must also display a label referring to the enclosed module. This exterior label can use wording such as the following: “Contains Transmitter Module FCC ID: 2AKS8DX-BT04-E Or Contains FCC ID:2AKS8DX-BT04-E”

When the module is installed inside another device, the user manual of the host must contain below warning statements;

1. This device complies with Part 15 of the FCC Rules. Operation is subject to the following two conditions:
(1) This device may not cause harmful interference.
(2) This device must accept any interference received, including interference that may cause undesired operation.

Note: This equipment has been tested and found to comply with the limits for a Class B digital device, pursuant to part 15 of the FCC Rules. These limits are designed to provide reasonable protection against harmful interference in a residential installation. This equipment generates, uses and can radiate radio frequency energy and, if not installed and used in accordance with the instructions, may cause harmful interference to radio communications.

However, there is no guarantee that interference will not occur in a particular installation. If this equipment does cause harmful interference to radio or television reception, which can be determined by turning the equipment off and on, the user is encouraged to try to correct the interference by one or more of the following measures:

- Reorient or relocate the receiving antenna.
- Increase the separation between the equipment and receiver.
- Connect the equipment into an outlet on a circuit different from that to which the receiver is connected.
- Consult the dealer or an experienced radio/TV technician for help.

2. Changes or modifications not expressly approved by the party responsible for compliance could void the user's authority to operate the equipment.

The devices must be installed and used in strict accordance with the manufacturer's instructions as described in the user documentation that comes with the product.

Any company of the host device which install this modular with single modular approval should perform the test of radiated & conducted emission and spurious emission,etc. according to FCC part 15C : 15.247 and 15.209 & 15.207 ,15B Class B requirement, Only if the test result comply with FCC part 15C : 15.247 and 15.209 & 15.207 ,15B Class B requirement, then the host can be sold legally.