

User Manual

Product Name: Bluetooth module

Model Name: DX-BT24

Manufacture: SHEN ZHEN DX-SMART TECHNOLOGY CO., LTD



Table Of Contents

1、 Overview	19
2、 Module Default Parameters	19
3、 Application Area.....	20
4、 Power consumption parameters.....	20
5、 Radio frequency characteristics.....	20
6、 Transparent Transmission Parameters	21
7、 Module Pin Description And Minimum Circuit Diagram.....	21
8、 Pin Function Description	22
9、 Detailed Description Of Function pins.....	23
10、 Dimensions	24
11、 LAYOUT Precautions.....	24
12、 AT COMMAND.....	26
12.1 Test Command	27
12.2 Get The Software Version.....	27
12.3 Query Module Bluetooth MAC.....	27
12.4 Set/Query Device Name.....	28
12.5 Settings\Query—Bluetooth name suffix MAC.....	28
12.6 Set/Query - Serial Port Baud Rate.....	28
12.7 Set/Query - Serial Port Stop Bit:.....	29
12.8 Set / Query - Serial Parity Bit:	29
12.9 Set/Query-Notify the host computer connection status.....	30
12.10 Set/Query - Notification connection with address code.....	30
12.11 Settings\Query - SERVICE UUID.....	30
12.12 Settings\Query - NOTIFY UUID\ WRITE UUID	30
12.13 Settings\Query - WRITE UUID	31
12.14 Settings\Query - Low Power Mode.....	31
12.15 Settings\Query - Broadcast time interval.....	31
12.16Settings\Query - Module transmit power.....	32
12.17 Settings\Query—APP AT command.....	32
12.18 Settings\Query—Bluetooth device type.....	33
12.19 Software restart.....	33
12.20 Restore default settings.....	33
13、 Contact Us.....	33



1. Overview

DX-BT24 5.1 Bluetooth module is built by Shenzhen DX-SMART Technology Co., Ltd. for intelligent wireless data transmission. It uses the British DAILOG 14531 chip, configures 256Kb space, and follows V5.1 BLE Bluetooth specification. Support AT command, users can change the serial port baud rate, device name, pairing password and other parameters as needed, flexible use.

This module supports UART interface and supports Bluetooth serial port transparent transmission. It has the advantages of low cost, small size, low power consumption, high sensitivity of sending and receiving, etc. It can realize its powerful functions with only a few peripheral components simple operation, high cost performance and technology leading edge.

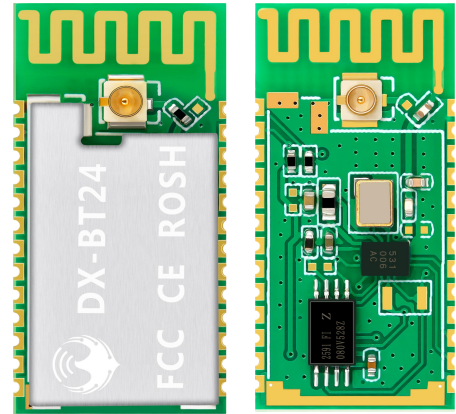

2. Module default parameters:

Bluetooth Protocol	Bluetooth Specification V5.1 BLE
Working Frequency	2.4GHz ISM band
Communication Interface	UART
Power Supply	3.3V
Communication distance	80M (Open and unobstructed environment)
Physical Dimension	27(L)mm x 13 (W)mm x 2(H) mm
Bluetooth Authentication	FCC CE ROHS REACH
Bluetooth Name	BT24
Serial Port Parameters	9600、8 data bits、1 stop bit、No check、No flow control
Service UUID	FFE0
Notify\Write UUID	FFE1
Write UUID	FFE2
Work temperature	MIN:-40℃ - MAX:+85℃
Customized requirements	If you have other special function requirements, you can contact us to customize the module.



3. Application area:

DX-BT24 module supports BT5.1 BLE protocol, which can be directly connected to iOS devices that have BLE Bluetooth function, and supports background program resident operation.

Successful application of BT24 module:

- ※ Bluetooth wireless data transmission;
- ※ Mobile phones, computer peripherals;
- ※ Handheld POS device;
- ※ Medical equipment wireless data transmission;
- ※ Smart Home Control;
- ※ Automotive Inspection OBD Equipment;
- ※ Bluetooth printer;
- ※ Bluetooth remote control toy;
- ※ Anti-lost device, LED light control;

4. Power consumption parameters:

Broadcast interval: 540ms			
Mode	Status	Current	Unit
Low power mode	Discoverable	19	uA
	Connected	341	uA
Normal working mode	Discoverable	270	uA
	Connected	341	uA
When transparently transmitting data(11520Bytes/s)	Connected	MIN:341uA MAX:3.5 (MIN is the minimum amount of data, MAX is the power consumption at the maximum amount of data)	mA

5. Radio frequency characteristics:

Rating	Value	Unit
BLE Transmit power	-19.5~+2.5	dBm
BLE Sensitivity	-94	dBm



6. Transparent transmission parameters

Data throughput:

Android ->BT24 -> UART		UART ->BT24 -> Android	
Baud rate	115200	Baud rate	115200
Connection interval (ms)	15	Connection interval (ms)	15
Serial packet size (bytes)	230	Serial packet size (bytes)	320
Transmission interval (ms)	20	Transmission interval (ms)	20
Throughput (bytes/s)	10120	Throughput (bytes/s)	10626
Characteristic Write	Write without Response	Characteristic Notify	Notify
iPhone 6 ->BT24 -> UART		UART ->BT24 -> iPhone 6	
Baud rate	115200	Baud rate	115200
Connection interval (ms)	30	Connection interval (ms)	30
Serial packet size (bytes)	140	Serial packet size (bytes)	180
Transmission interval (ms)	20	Transmission interval (ms)	50
Throughput (bytes/s)	5600	Throughput (bytes/s)	3240
Characteristic Write	Write without Response	Characteristic Notify	Notify

Note: This table parameter is for reference only and does not represent the maximum data throughput that the module can support.

7. Module pin description and minimum circuit diagram:

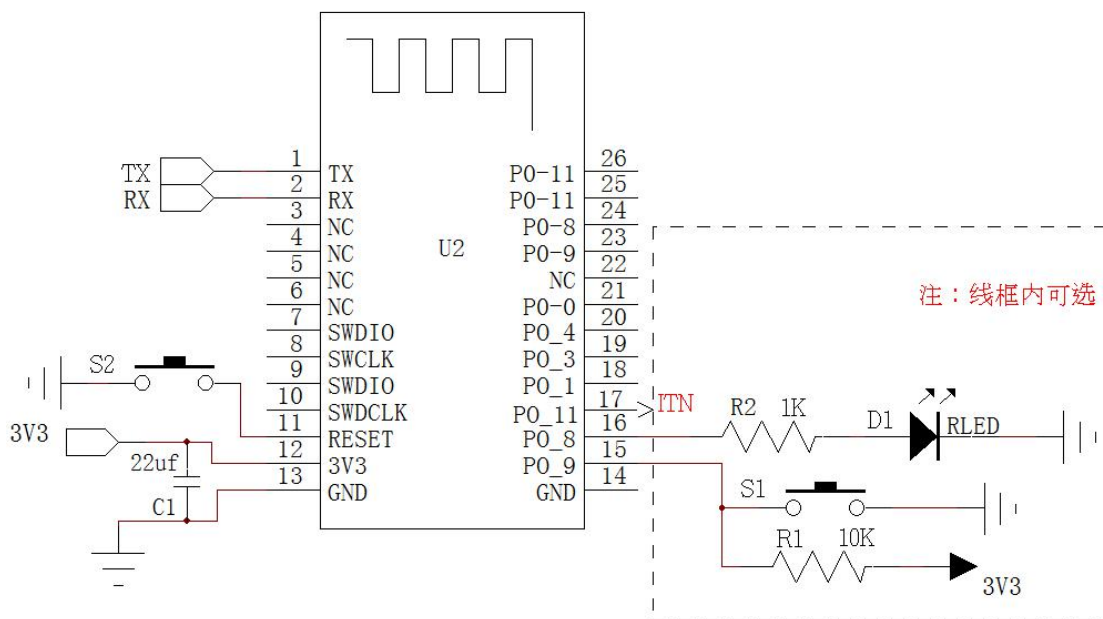



8. Pin function description:

Pin number	Pin name	Pin description
1	P0_6	Serial data output
2	P0_7	Serial data input
3	NC	NC
4	NC	NC
5	NC	NC
6	NC	NC
7	SWDIO	Debug data port
8	SWCLK	Debug clock port
9	SWDIO	Connected to pin 7, IO port can be customized
10	SWCLK	Connected to pin 8, IO port can be customized
11	Reset	Reset (Input 200ms low level pulse)
12	VCC	V3.3
13	GND	Land
14	GND	Land
15	P0_9	Disconnect pin(200ms low power pulse disconnection) Low power mode wake up(200ms low power pulse wake up)
16	P0_8	LED light pin(Not connected: 1s on, 1s off, connected: 3s on, 50ms off)
17	P0_11	Bluetooth connection indicator (not connected low, connection high)
18	P0_1	NC (Can only be left floating)
19	P0_3	NC (Can only be left floating)
20	P0_4	NC (Can only be left floating)
21	P0_0	Programmable input and output
22	NC	NC
23	P0_9	Connected to pin 15, IO port can be customized
24	P0_8	Connected to pin 16, IO port can be customized
25	P0_11	Connected to pin 17, IO port can be customized
26	P0_11	Connected to pin 17, IO port can be customized



9. Detailed description of function pins:

1、16 feet (P0_8): LED indicator pin

• Used to indicate the status of the Bluetooth module, the LED flashing mode corresponds to the status of the Bluetooth module, see the table below:

Module	LED display	Module status
Slave module	Flashes slowly and evenly (1s-on, 1s-off)	standby mode
	Bright 3s Extinguish 50ms (3s-on, 50ms-off)	Connection Status
	Light off in low power mode	

2、Pin 17 (P1_11): connection status indication pin

Pin status	Module status
Output low	standby mode
Output high level	Connection Status

3、Pin 15 (P0_9): connection interruption pin (the module is in the connected state is valid)

Pin status	Module status
No action	Connection Status
Input 200ms low-level pulse from the module	The connection is interrupted and the module enters low power consumption mode (Enter the previously set working mode, if not set, it is the normal working mode)

4、Pin15 (P0_9): low-power mode wake-up pin (the module is effective in low-power mode)

Pin status	Module status
No action	Low power mode
Input 200ms low-level pulse from the module	Wake up from low power mode, the module enters the standby state

5、Comparison of low power mode and normal working mode

	Normal working mode	Low power mode
AT command	Send AT commands after power-on	P0_9: 200ms low power pulse wake up to send AT command
Light status	Even slow blinking	light is not on



10. Dimensions:

厚度: $2.3\text{mm} \pm 0.2\text{mm}$

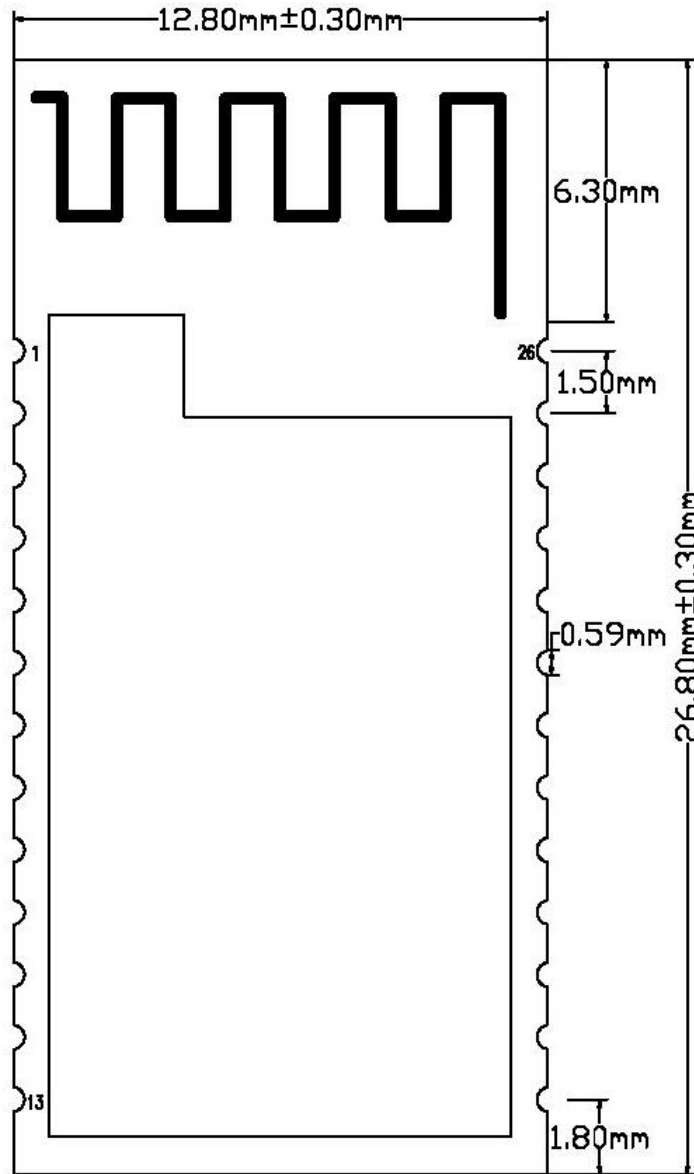

11. LAYOUT Precautions:

The DX-BT24 Bluetooth module works in the 2.4G wireless band. It should try to avoid the influence of various factors on the wireless transceiver. Pay attention to the following points:

1. the product shell surrounding the Bluetooth module to avoid the use of metal, when using part of the metal shell, should try to make the module antenna part away from the metal part.
2. The internal metal connecting wires or metal screws of the product should be far away from the antenna part of the module.



3. The antenna part of the module should be placed around the PCB of the carrier board. It is not allowed to be placed in the board, and the carrier board under the antenna is slotted. The direction parallel to the antenna is not allowed to be copper or traced. It is also a good choice to directly expose the antenna part out of the carrier board.

4. It is recommended to use insulating material for isolation at the module mounting position on the substrate. For example, put a block of screen printing (TopOverLay) at this position.

(Recommend)

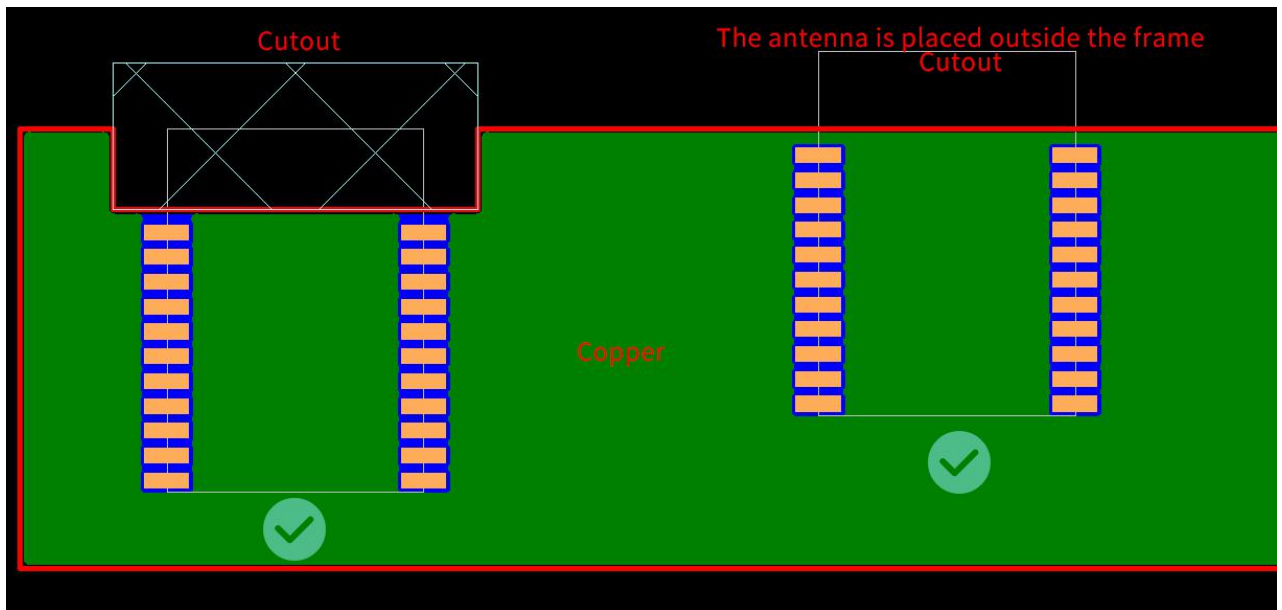

(Not recommend)

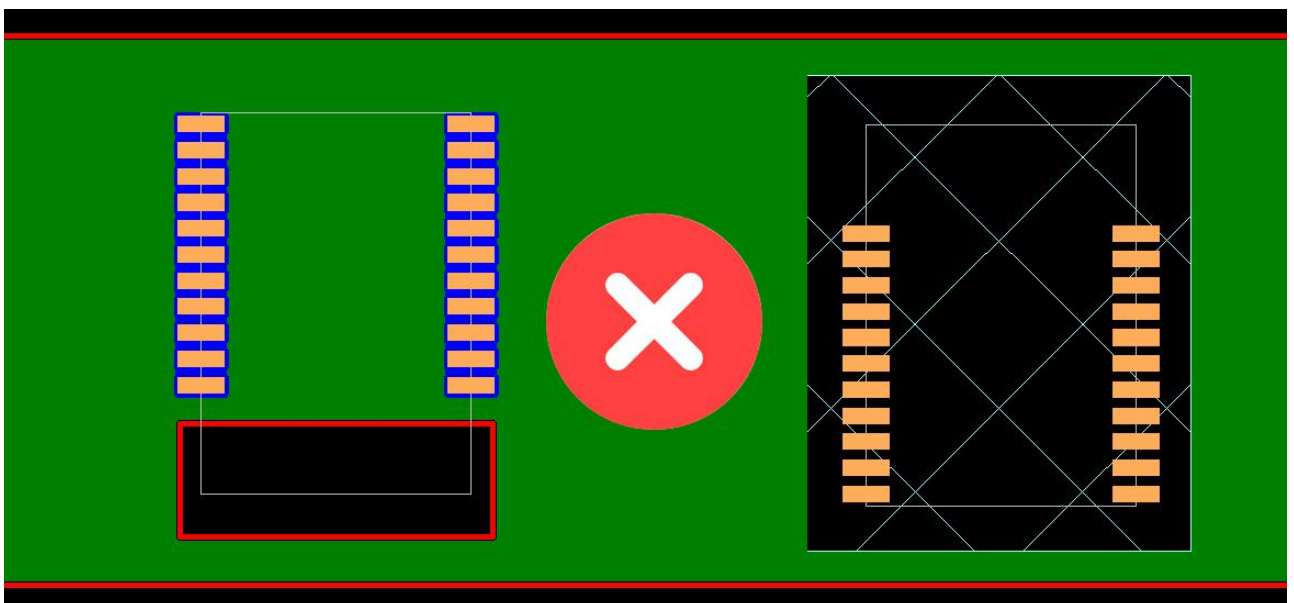



12. AT COMMAND

(Note: AT command mode when the module is not connected)

1. AT command, which belongs to the character line instruction, is parsed according to the line (that is, AT command must be returned by carriage return or `\r\n`, hexadecimal number is 0D0A)
2. The AT command supports case and the instruction prefix is AT+, which can be divided into parameter setting instructions and read instructions.
3. Set the instruction format: AT+<CMD><PARAM> Operation returns successfully: +<CMD>=<PARAM>\r\n OK\r\n Failure does not return characters. **In addition to the 9th and 10th settings, the other parameters need to be restarted after setting the parameters for the new parameters to take effect.**
4. Read instruction format: AT+<CMD>Operation succeeds: +<CMD>=<PARAM>\r\n Failure does not return a return character.

AT command format example (Figure 1 is AT test command, Figure 2 is to change the Bluetooth name to 1234):

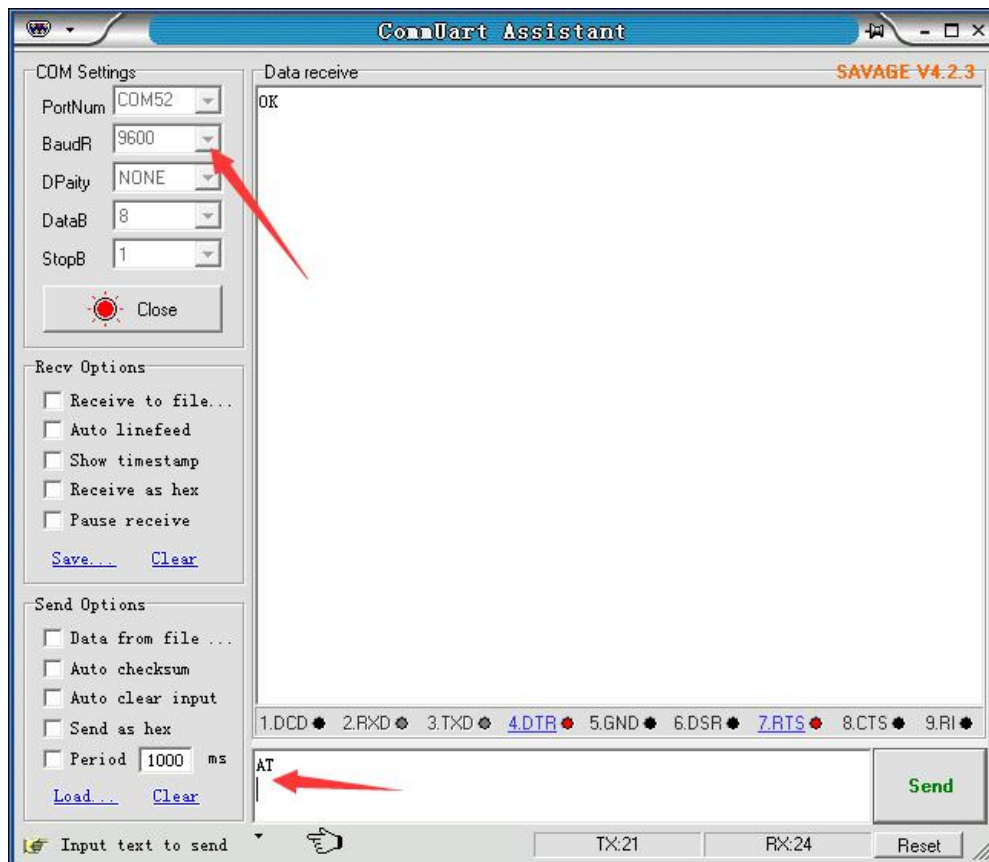

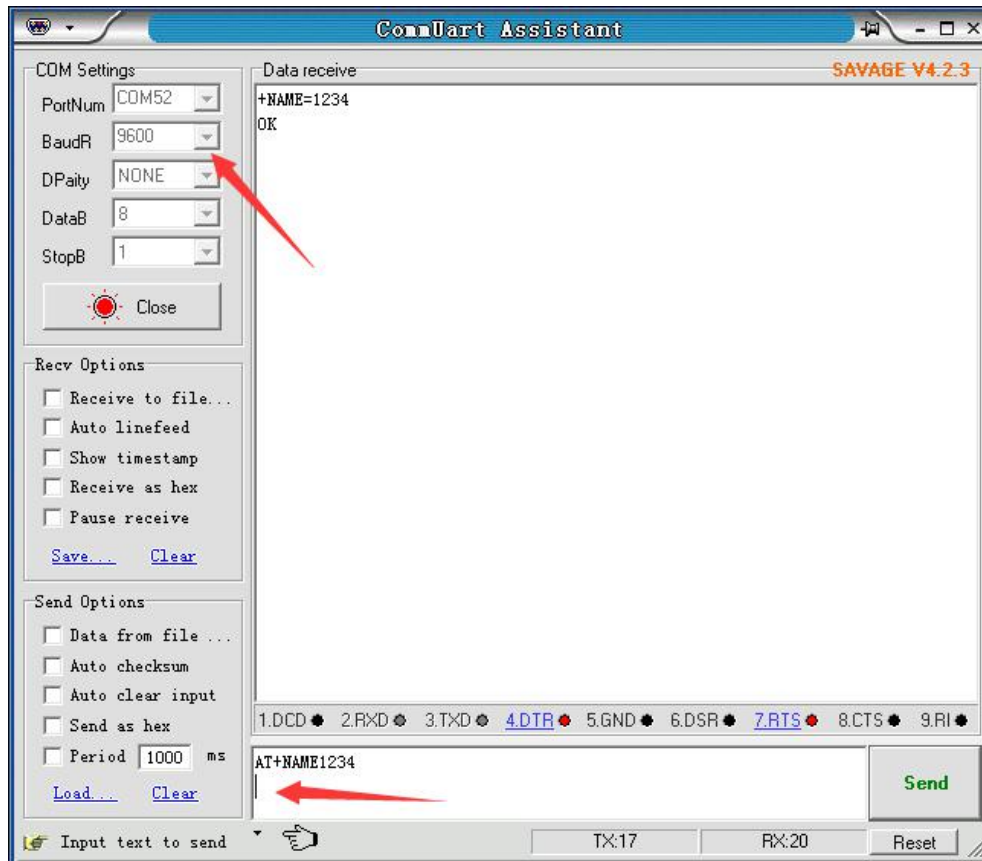

1、 Test Command:

Function	Command	Response	Description
Test instructions	AT\r\n	OK\r\n	

2、 Get The Software Version:

Function	Command	Response	Description
Query version number	AT+VERSION\r\n	+VERSION=<version>\r\n OK\r\n	<version > Software version number

Note:The version will be different depending on different modules and customization requirements.

3、 Query Module Bluetooth MAC:

Function	Command	Response	Description
Query module MAC address	AT+LADDR\r\n	+LADDR=<laddr>\r\n	<laddr> Bluetooth 12-bit MAC Address Code



4、Set/Query Device Name:

Function	Command	Response	Description
Query module Bluetooth name	AT+NAME\r\n	+NAME=<name>\r\n	<name> Bluetooth name, up to 20 bytes
Set the module Bluetooth name	AT+NAME<name>\r\n	+NAME=<name>\r\n OK	Default name: BT24

Example:

1. Send Settings:

AT+NAME=DX-BT24\r\n ——Set module device name: “DX-BT24”

return:

+NAME=DX-BT24\r\n ——Set module device name: “DX-BT24” succeeded

OK\r\n

2. Send inquiry:

AT+NAME\r\n ——Query module name

return:

+NAME=DX-BT24\r\n ——Return module device name: “DX-BT24”

5、Settings\Query—Bluetooth name suffix MAC:

Function	Command	Response	Description
Query Bluetooth name suffix MAC	AT+NAMAC\r\n	+NAMAC=<Param>\r\n	<Param > (0, 1, 2) 0: No MAC suffix after the name
Set Bluetooth name suffix MAC	AT+NAMAC<Param>\r\n	+NAMAC=<Param>\r\n OK	1:Open name suffix 12-digit MAC。 2:Open name suffix 6-digit MAC。 Default: 0

6、Set/Query - Serial Port Baud Rate:

Function	Command	Response	Description
Query module baud	AT+BAUD\r\n	+BAUD=<baud>\r\n	<baud> Baud rate



Set the module baud	AT+BAUD<baud>\r\n	+BAUD=<baud>\r\n OK\r\n	corresponding serial number 1:2400 2:4800 3:9600 4:19200 5:38400 6:57600 7:115200 Default: 3(9600)
---------------------	-------------------	----------------------------	--

Note: The module must be re-powered after setting the baud rate, enabling the new baud rate for data communication and AT command resolution.

Example: Setting the Serial Port Baud Rate: 57600

1. Send Settings:

AT+BAUD6\r\n

return:

+BAUD=6\r\n

OK\r\n

2. Send inquiry:

AT+BAUD?\r\n

return:

+BAUD=6\r\n

OK\r\n

7、Set/Query - Serial Port Stop Bit:

Function	Command	Response	Description
Query module serial port stop bit	AT+STOP\r\n	+STOP=<Param>\r\n	< Param> Stop bit 0 -1 Stop bit
Set module serial port stop bit	AT+STOP<Param>\r\n	+STOP=<Param>\r\n OK	1 -2 Stop bit Default: 0

8、Set / Query - Serial Parity Bit:

Function	Command	Response	Description
Query module serial parity bit	AT+PARI\r\n	+PARI=<Param>\r\n	< Param> Check Digit 0 -1 No check
Set the module serial parity bit	AT+PARI<Param>\r\n	+PARI=<Param>\r\n OK	1 -2 Odd parity 2 -2 Even parity



			Default: 0
--	--	--	------------

9、Set/Query—Notify the host computer connection status : The connection success module returns OK+CONN:

Function	Command	Response	Description
Query status	AT+NOTI\r\n	+NOTI=<Param>\r\n	< Param> Check Digit 0- Not notified 1- Notice Defaults: 0
Set status	AT+NOTI<Param>\r\n	+NOTI=<Param>\r\n OK	

10、Set/Query—Notification connection with address code: The connection success module returns OK+CONN0x112233445566:

Function	Command	Response	Description
Notification connection with address code	AT+NOTP\r\n	+NOTP=<Param>\r\n	< Param> Check Digit 0- Not notified 1- Notice Defaults: 0
Notification connection with address code	AT+NOTP<Param>\r\n	+NOTP=<Param>\r\n OK	

11、Settings\Query—SERVICE UUID:

Function	Command	Response	Description
Query service UUID	AT+UUID\r\n	+UUID =<service>\r\n	<service> UUID Default service UUID:FFE0 (This UUID is a 4-digit hexadecimal number)
Set service UUID	AT+UUID<service>\r\n	+UUID =<service>\r\n OK	

Example: Set the service UUID to: FE00

1. Send Settings:

AT+UUIDD0XFF00\r\n

return:

+UUID=0XFF00 r\n

OK

12、Settings\Query—NOTIFY UUID\ WRITE UUID:

Function	Command	Response	Description
----------	---------	----------	-------------



Query module notify\write UUID	AT+CHAR\r\n	+CHAR=<UUID >\r\n	<UUID>notify\write UUID
Set module notify \write UUID	AT+CHAR<UUID> \r\n	+CHAR =<UUID>\r\n OK	Default: FFE1 (This UUID is a 4-digit hexadecimal number)

Note: This channel is a readable and writable channel (ie it can be read or written)

Example: Set the notify \write UUID to: FE01

1. Send settings:

```
AT+CHAR0xFE01\r\n
```

return:

```
+CHAR= FE01\r\n
```

```
OK\r\n
```

13、Settings\Query—WRITE UUID:

Function	Command	Response	Description
Query module write UUID	AT+WRITE\r\n	+WRITE=<UUID >\r\n	<UUID> write UUID Default: FFE2
Set module write UUID	AT+WRITE<UUID >\r\n	+WRITE=<UUID>\r\n OK	(This UUID is a 4-digit hexadecimal number)

14、Settings\Query - Low Power Mode:

Function	Command	Response	Description
Query module low power mode	AT+PWRM\r\n	+PWRM=<Param>\r\n	< Param >(0、 1) 0: Low power mode
Set module low power mode	AT+PWRM<Para m>\r\n	+PWRM=<Param>\r\n OK	1: working mode Default: 1

15、Settings\Query - Broadcast time interval:

Function	Command	Response	Description
Query Broadcast time interval	AT+ ADVI \r\n	+ ADVI=<Param>\r\n	Param: 0~F 0—100ms 1—152.5ms



Set Broadcast time interval	AT+ADVI<Param>\r\n	+ ADVI=<Param>\r\n OK	2—211.25ms 3—318.75ms 4—417.5ms 5—546.25ms 6—760ms 7—852.5ms 8—1022.5ms 9—1285ms A—2000ms B—3000ms C—4000ms D—5000ms E—6000ms F—7000ms Default: 5
-----------------------------	--------------------	--------------------------	---

Note: This instruction can be used to reduce power consumption

16、Settings\Query - Module transmit power:

Function	Command	Response	Description
Query module transmit power	AT+POWE\r\n	+POWE=<POWE>\r\n	<POWE>: 1: -19.5 dB 2: -13.5 dB
Set module transmit power	AT+POWE<POWE>\r\n	+POWE=<POWE>\r\n OK\r\n	3: -10dB 4: -7dB 5: -5dB 6: -3.5dB 7: -2dB 8: -1dB 9: 0dB A: +1dB B: +1.5dB C: +2.5dB Default: C

17、Settings\Query—APP AT command:

Function	Command	Response	Description
Query APP AT commands	AT+APPAT\r\n	+APPAT=<Param>\r\n	<Param > (0, 1, 2)
Set APP AT command	AT+APPAT<Param>\r\n	+APPAT=<Param>\r\n	0:Close APP AT command



		OK	1:Open APP AT command Default: 0
--	--	----	-------------------------------------

Note: This command opens the user to send AT commands with APP (Note: APPAT command can only be enabled through UART; if you need to enter transparent transmission mode, you need to set to disable APP AT command.)

18、Settings\Query—Bluetooth device type:

Function	Command	Response	Description
Query Bluetooth device type	AT+TYPE\r\n	+TYPE=<Param>\r\n	<Param >: 0x0000:No types pecified 0x0040:Phone type
Set Bluetooth device type	AT+TYPE<Param>\r\n	+TYPE=<Param>\r\n OK	0x0080:Laptop type 0x03c1:Keyboard type 0x03c2:Mouse type ... Default: 0x0000

19、Software restart:

Function	Command	Response	Description
Software restart	AT+RESET\r\n	OK\r\n	

20、Restore default settings:

Function	Command	Response	Description
Restore default settings	AT+DEFAULT\r\n	OK\r\n	

13. Contact us

Shen Zhen DX-SMART Technology Co., Ltd.

Address: 511 ,Building C, Yuxing Technology Park, Yuxing Chuangu, Bao'an District, Shenzhen, China

Tel: 0755-2997 8125 **Fax:** 0755-2997 8369

Website: <http://www.szdx-smart.com/>

FCC Statement

FCC standards: FCC CFR Title 47 Part 15 Subpart C Section 15.247

Integral antenna with antenna gain 2.5dBi

This device complies with part 15 of the FCC Rules. Operation is subject to the following two conditions: (1) This device may not cause harmful interference, and (2) this device must accept any interference received, including interference that may cause undesired operation.

Any Changes or modifications not expressly approved by the party responsible for compliance could void the user's authority to operate the equipment.

Note: This equipment has been tested and found to comply with the limits for a Class B digital device, pursuant to part 15 of the FCC Rules. These limits are designed to provide reasonable protection against harmful interference in a residential installation. This equipment generates, uses and can radiate radio frequency energy and, if not installed and used in accordance with the instructions, may cause harmful interference to radio communications. However, there is no guarantee that interference will not occur in a particular installation. If this equipment does cause harmful interference to radio or television reception, which can be determined by turning the equipment off and on, the user is encouraged to try to correct the interference by one or more of the following measures:

- Reorient or relocate the receiving antenna.
- Increase the separation between the equipment and receiver.
- Connect the equipment into an outlet on a circuit different from that to which the receiver is connected.
- Consult the dealer or an experienced radio/TV technician for help.

FCC Radiation Exposure Statement

This modular complies with FCC RF radiation exposure limits set forth for an uncontrolled environment.

If the FCC identification number is not visible when the module is installed inside another device, then the outside of the device into which the module is installed must also display a label referring to the enclosed module. This exterior label can use wording such as the following: "Contains Transmitter Module FCC ID: 2AKS8DX-BT24 Or Contains FCC ID: 2AKS8DX-BT24"

When the module is installed inside another device, the user manual of the host must contain below warning statements;

1. This device complies with Part 15 of the FCC Rules. Operation is subject to the following two conditions:
 - (1) This device may not cause harmful interference.
 - (2) This device must accept any interference received, including interference that may cause undesired operation.

Note: This equipment has been tested and found to comply with the limits for a Class B digital device, pursuant to part 15 of the FCC Rules. These limits are designed to provide reasonable protection against harmful interference in a residential installation. This equipment generates, uses and can radiate radio frequency energy and, if not installed and used in accordance with the instructions, may cause harmful interference to radio communications.

However, there is no guarantee that interference will not occur in a particular installation. If this equipment does cause harmful interference to radio or television reception, which can be determined by turning the equipment off and on, the user is encouraged to try to correct the interference by one or more of the following measures:

- Reorient or relocate the receiving antenna.
- Increase the separation between the equipment and receiver.
- Connect the equipment into an outlet on a circuit different from that to which the receiver is connected.
- Consult the dealer or an experienced radio/TV technician for help.

2. Changes or modifications not expressly approved by the party responsible for compliance could void the user's authority to operate the equipment.

The devices must be installed and used in strict accordance with the manufacturer's instructions as described in the user documentation that comes with the product.

Any company of the host device which install this modular with single modular approval should perform the test of radiated & conducted emission and spurious emission,etc. according to FCC part 15C : 15.247 and 15.209 & 15.207 ,15B Class B requirement, Only if the test result comply with FCC part 15C : 15.247 and 15.209 & 15.207 ,15B Class B requirement , then the host can be sold legally.