

GPRS:

Cellular Band (Part 22H) result

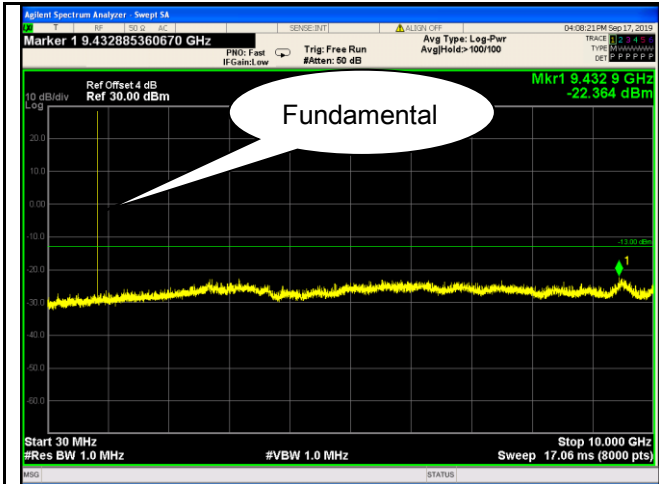

GSM 850 - Low Channel

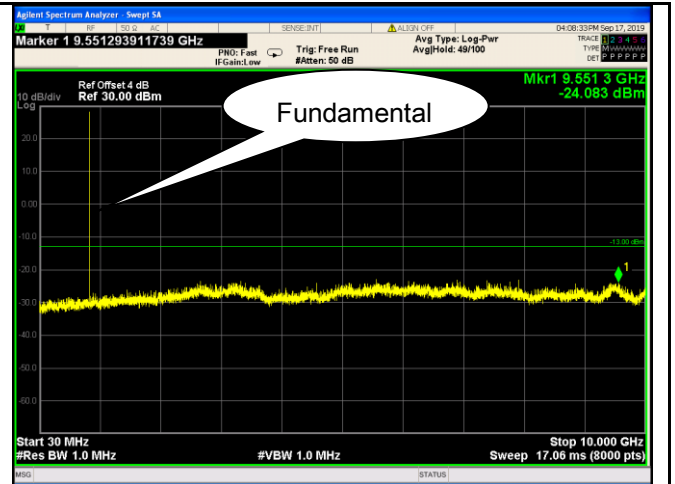

GSM 850 Middle Channel

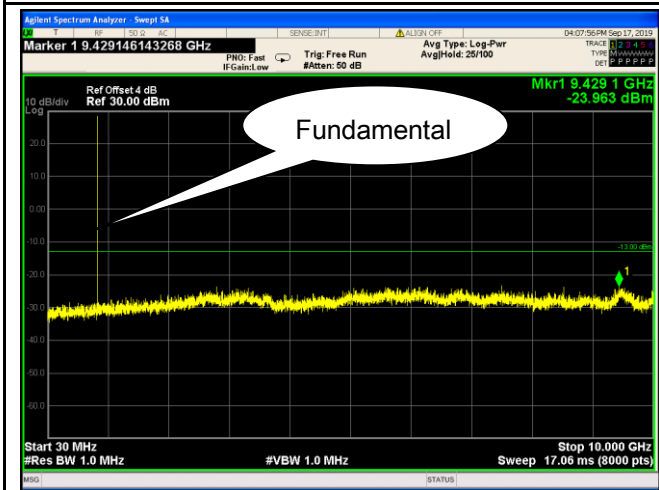

GSM 850 - High Channel

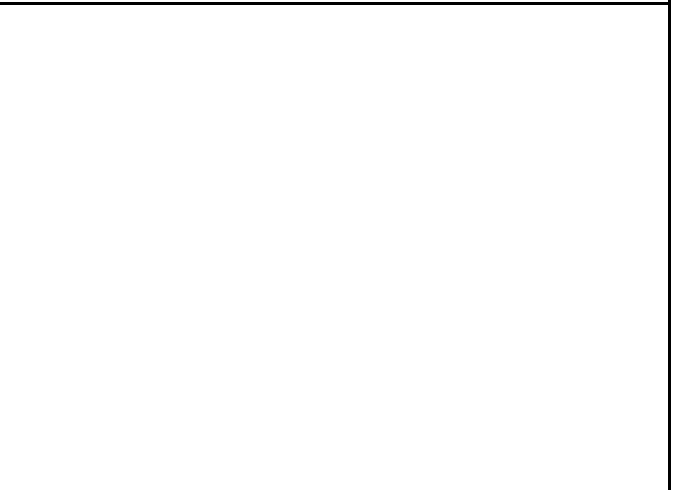

PCS Band (Part24E) result

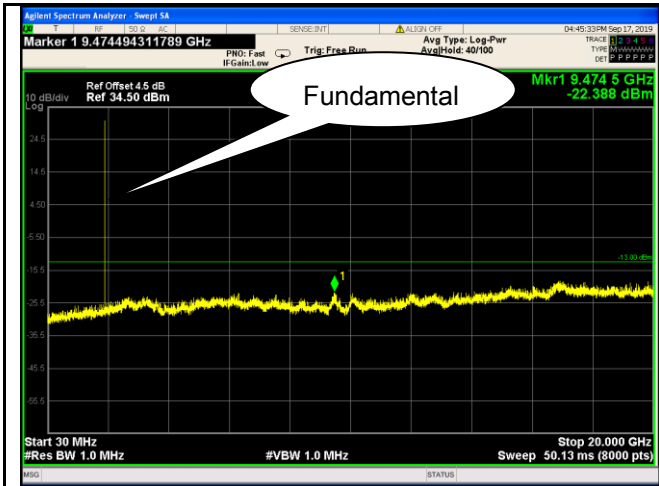

PCS1900 - Low Channel

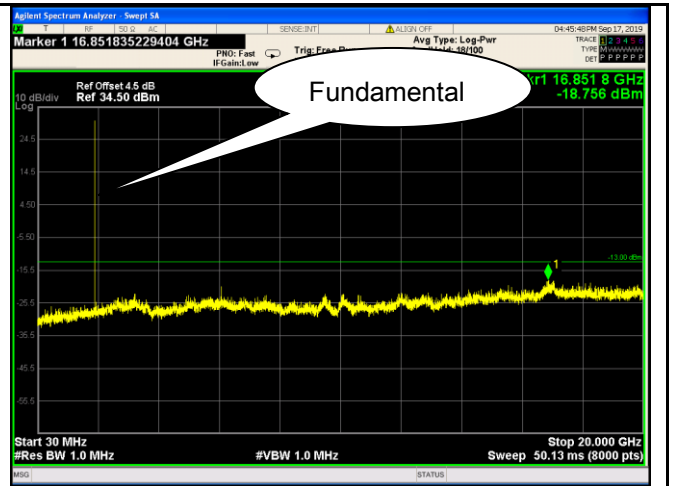

PCS1900 - Middle Channel

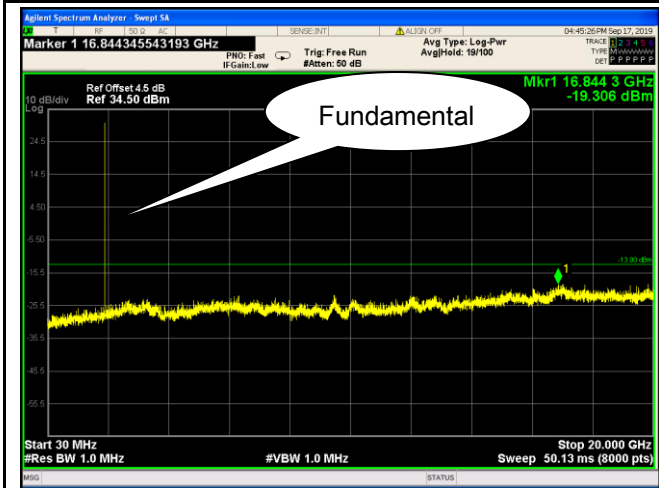

PCS1900 - High Channel

EGPRS (MSC 1):
Cellular Band (Part 22H) result

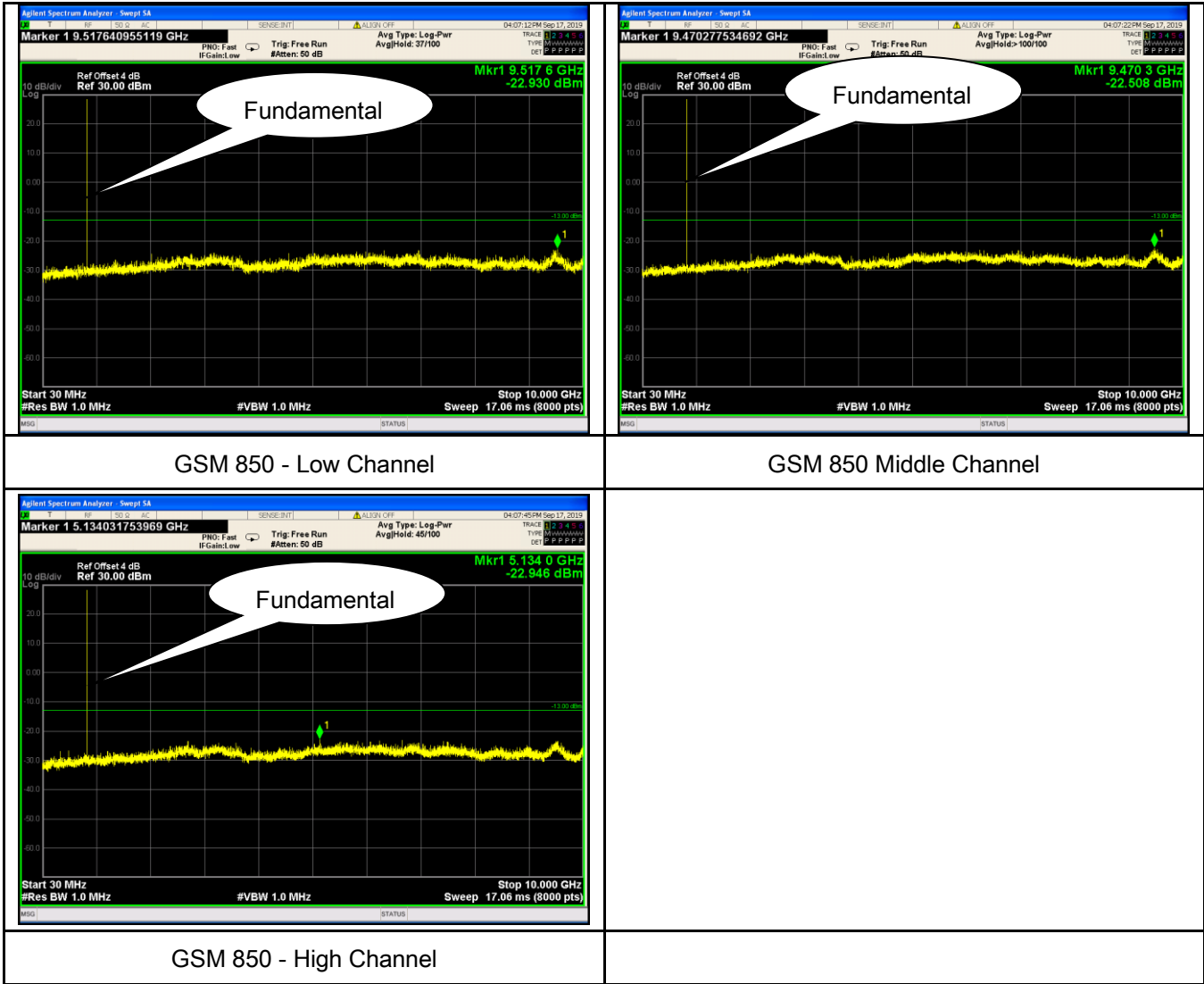

PCS Band (Part24E) result

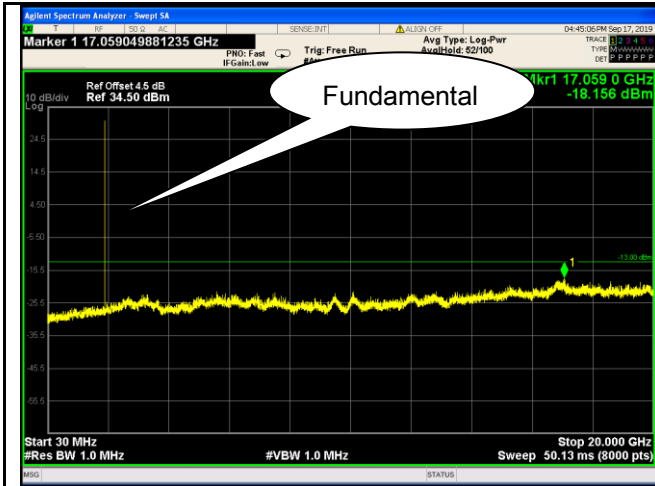

PCS1900 - Low Channel

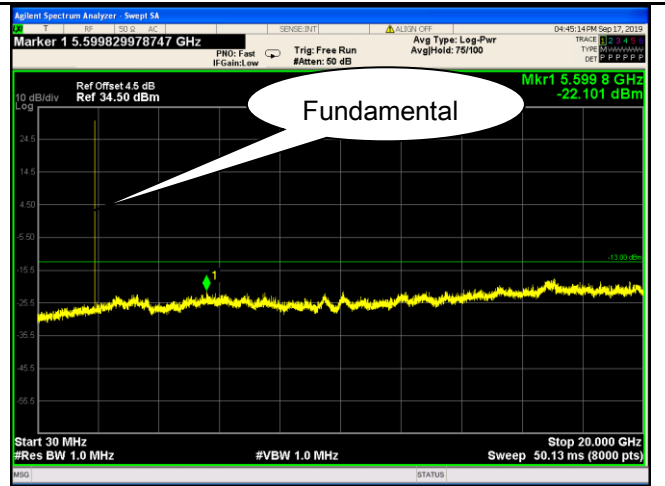

PCS1900 - Middle Channel

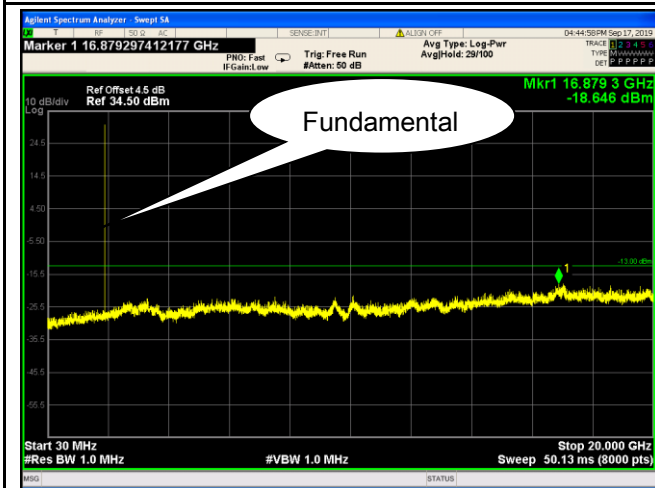

PCS1900 - High Channel

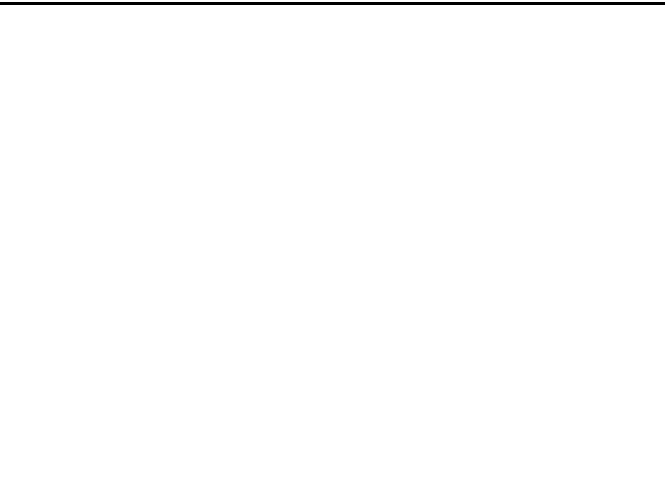

RMC

UMTS-FDD Band V (Part 22H)

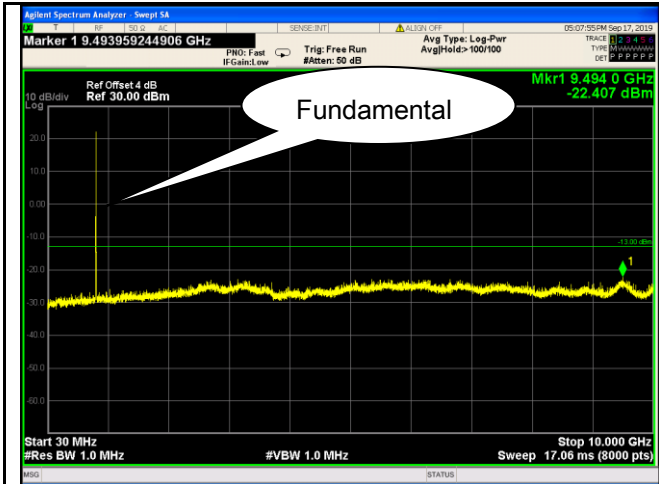

Band V - Low Channel

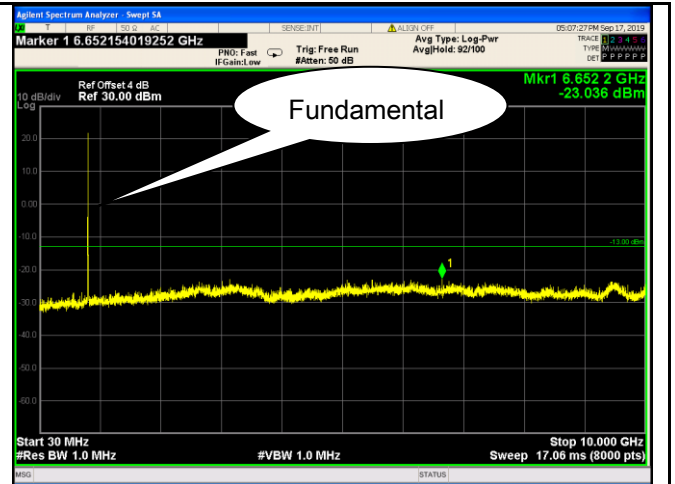

Band V - Middle Channel

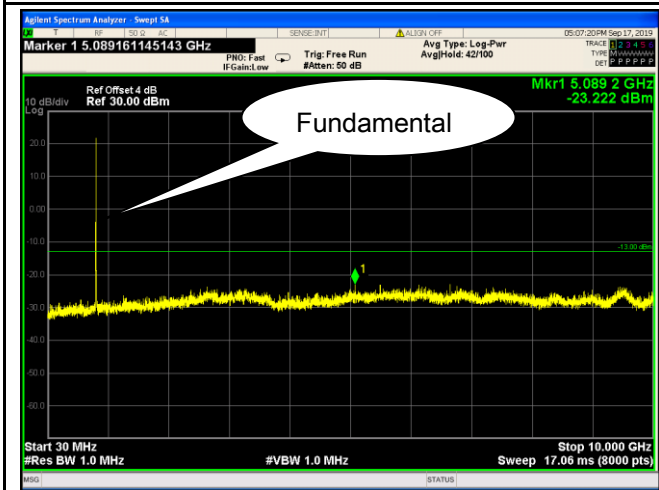

Band V - High Channel

UMTS-FDD Band II (Part 24E)

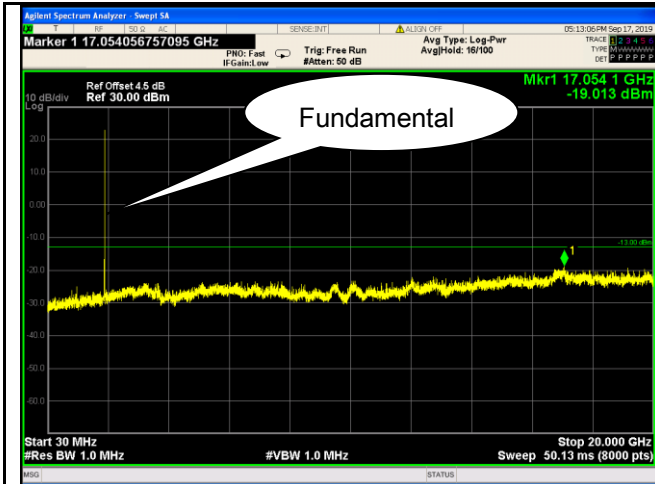

Band II - Low Channel

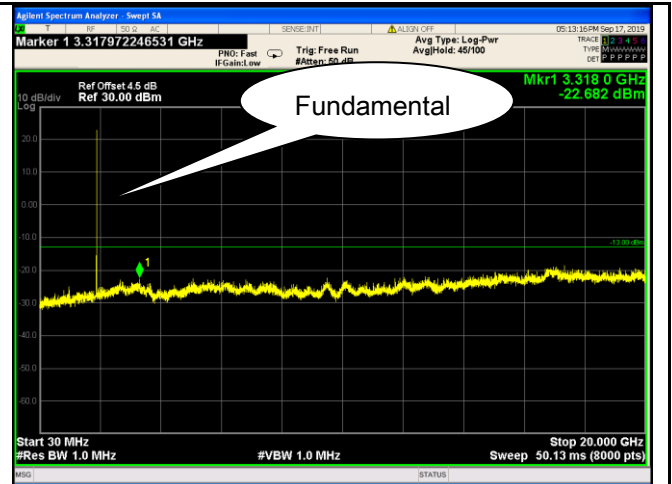

Band II - Middle Channel

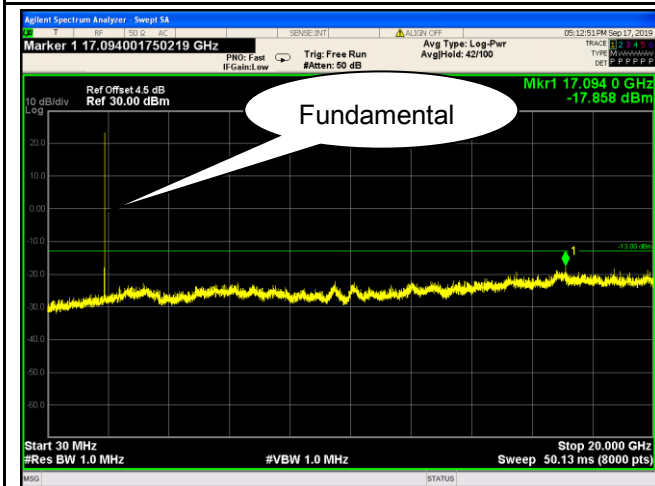

Band II - High Channel

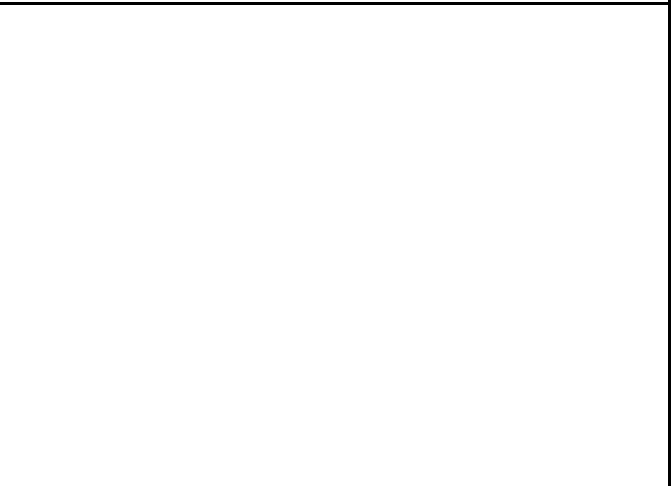

HSDPA:

UMTS-FDD Band V (Part 22H)

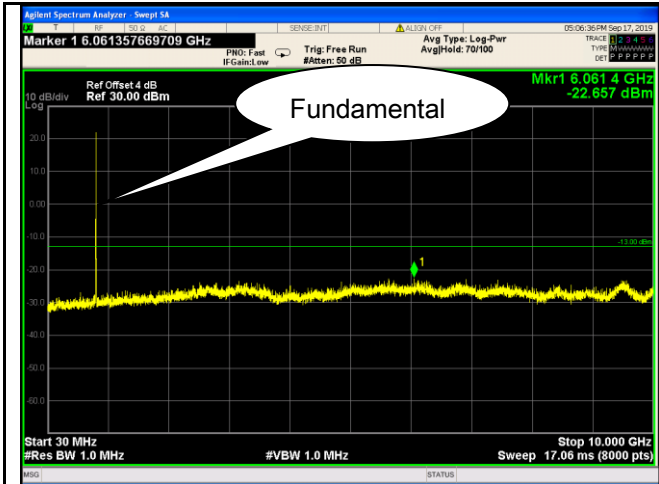

Band V - Low Channel

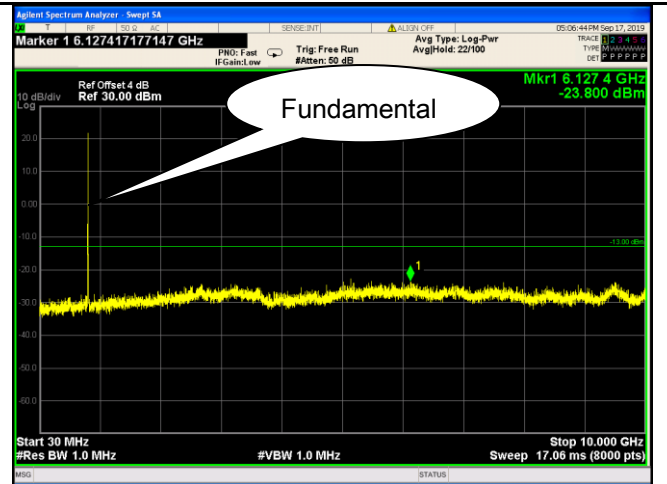

Band V - Middle Channel

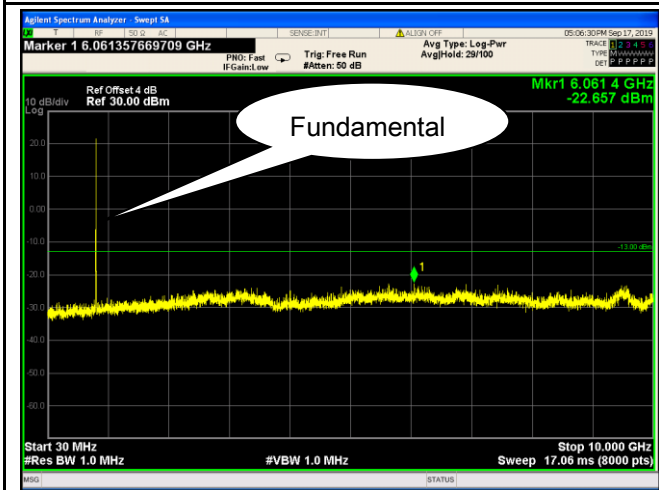

Band V - High Channel

UMTS-FDD Band II (Part 24E)

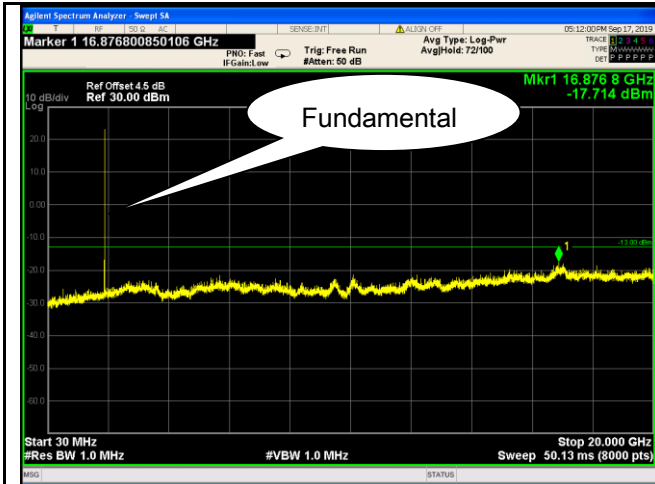

Band II - Low Channel

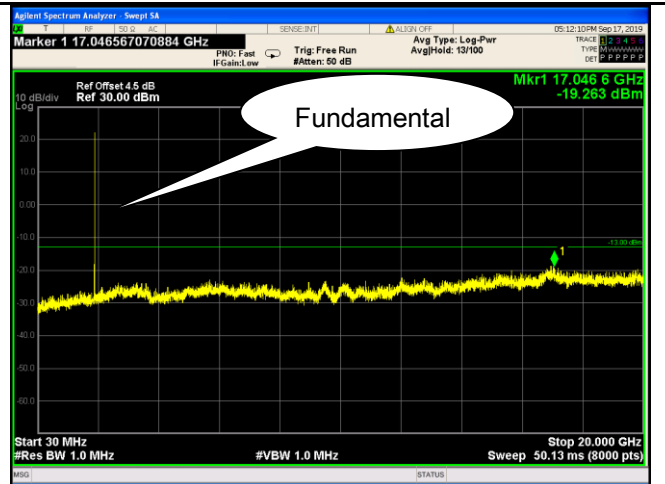

Band II - Middle Channel

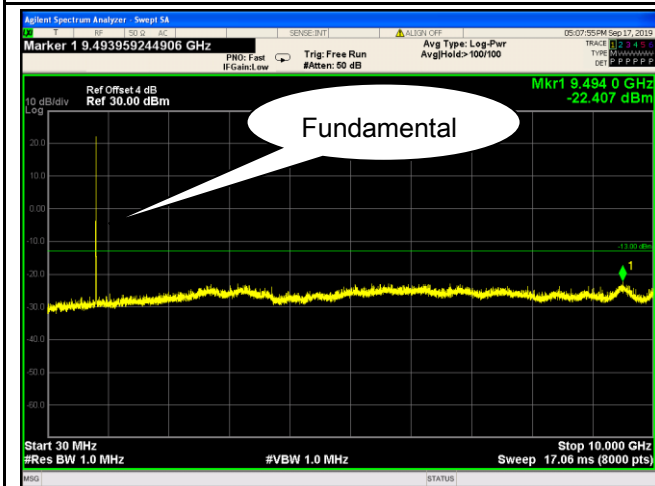

Band II - High Channel

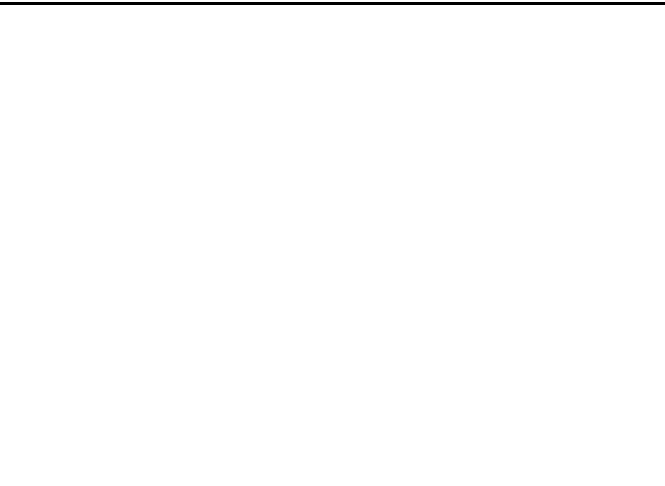

HSUPA:

UMTS-FDD Band V (Part 22H)

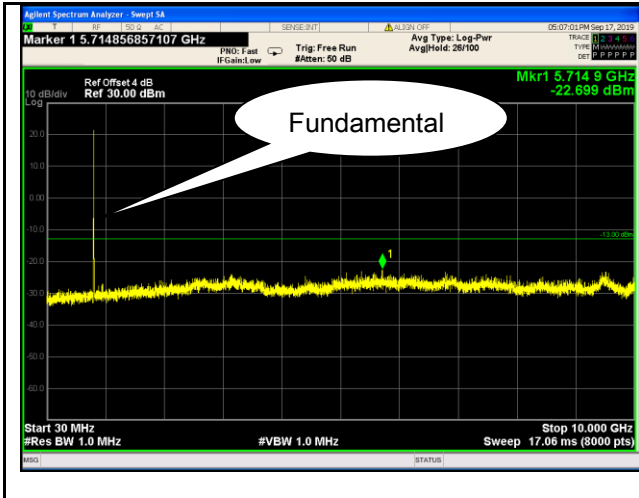

Band V - Low Channel

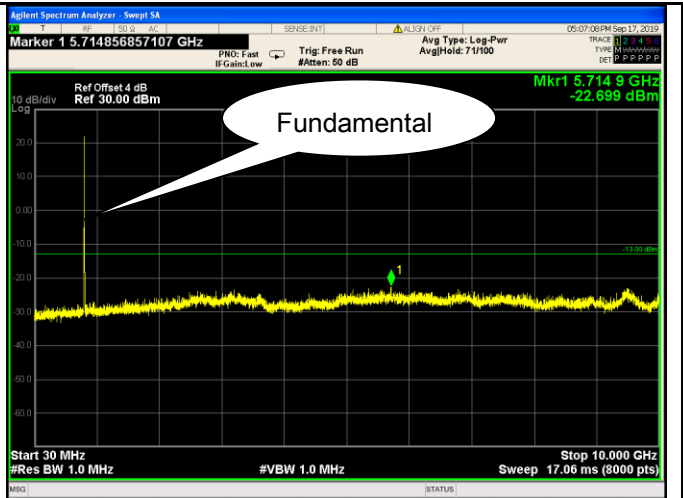

Band V - Middle Channel

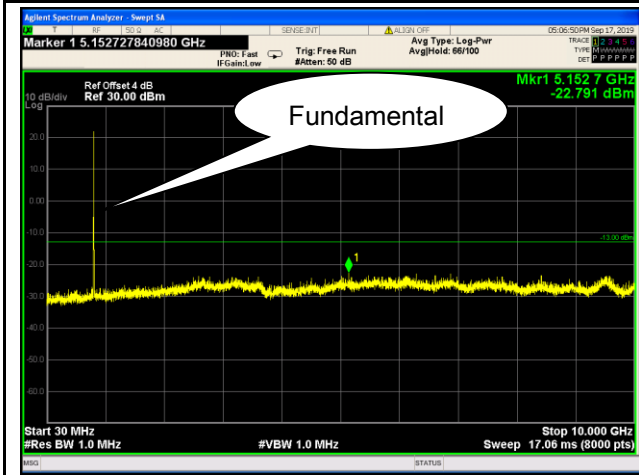

Band V - High Channel



UMTS-FDD Band II (Part 24E)

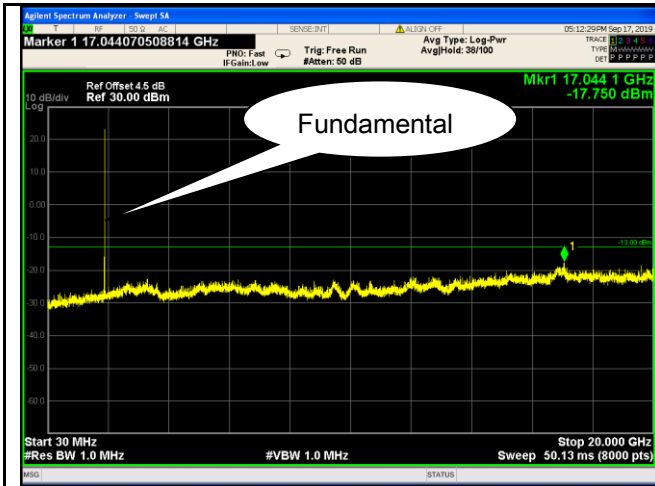

Band II - Low Channel

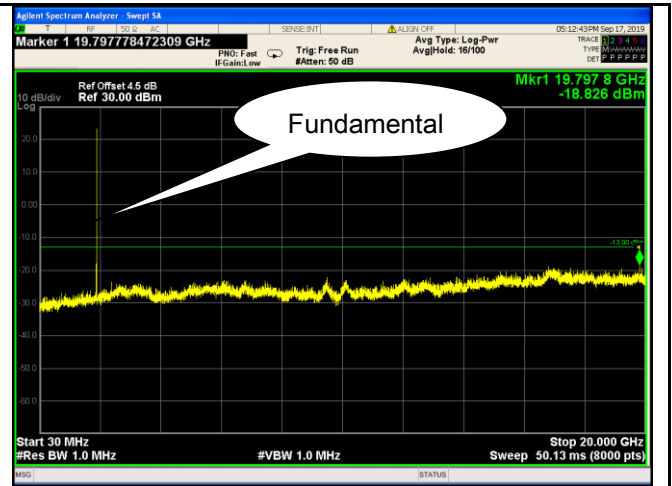

Band II - Middle Channel

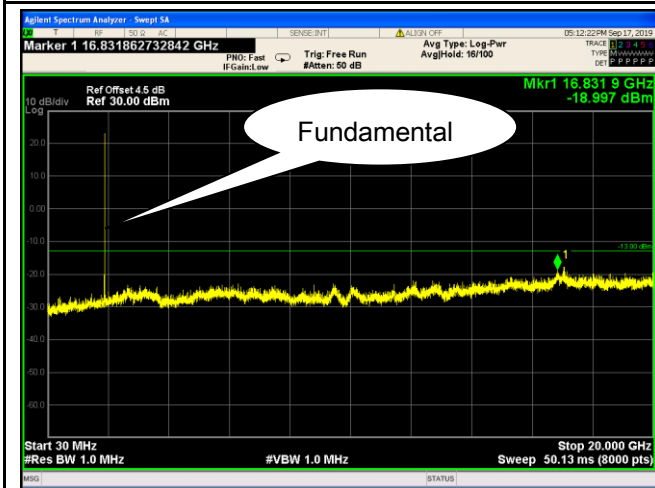

Band II - High Channel

6.6 Spurious Radiated Emissions

Temperature	23°C
Relative Humidity	66%
Atmospheric Pressure	1013mbar
Test date :	Sep 17,2019
Tested By :	Aaron Liang

Requirement(s):

Spec	Item	Requirement	Applicable
§2.1053, §22.917 & §24.238	a)	The power of any emission outside of the authorized operating frequency ranges must be attenuated below the transmitter power (P) by a factor of at least $43 + 10 \log (P)$ dB. The spectrum is scanned from 30 MHz up to a frequency including its 10th harmonic.	<input checked="" type="checkbox"/>

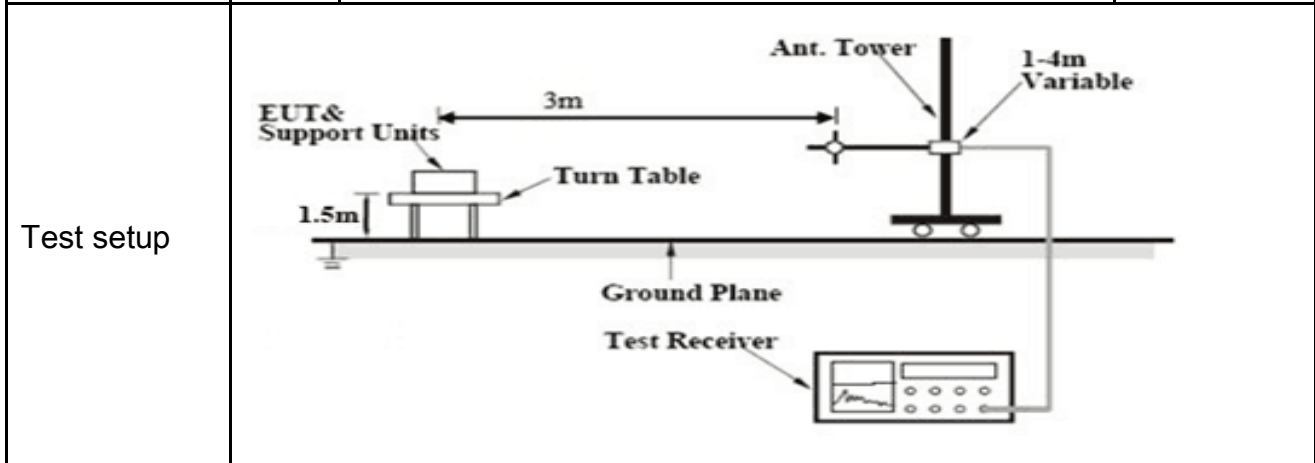

Test Procedure	<ol style="list-style-type: none"> The transmitter was placed on a wooden turntable, and it was transmitting into a non-radiating load which was also placed on the turntable. The measurement antenna was placed at a distance of 3 meters from the EUT. During the tests, the antenna height and polarization as well as EUT azimuth were varied in order to identify the maximum level of emissions from the EUT. The test was performed by placing the EUT on 3-orthogonal axis. Remove the EUT and replace it with substitution antenna. A signal generator was connected to the substitution antenna by a non-radiating cable. The absolute levels of the spurious emissions were measured by the substitution. <p>Sample Calculation:</p> <p>EUT Field Strength = Raw Amplitude (dBμV/m) – Amplifier Gain (dB) + Antenna Factor (dB) + Cable Loss (dB) + Filter Attenuation (dB, if used)</p>
----------------	--

Remark	
Result	<input checked="" type="checkbox"/> Pass <input type="checkbox"/> Fail

Test Data Yes N/A
Test Plot Yes (See below) N/A

Cellular Band (Part 22H) result

Low channel

Frequency (MHz)	Antenna Polarization (H/V)	Corrected Reading (dBm)	Limit (dBm)	Margin (dB)
1648.4	V	-37.59	-13	-24.59
1648.4	H	-42.16	-13	-29.16
2472.6	V	-33.26	-13	-20.26
2472.6	H	-32.31	-13	-19.31
165.4	V	-50.36	-13	-37.36
333.5	H	-51.28	-13	-38.28

Middle channel

Frequency (MHz)	Antenna Polarization (H/V)	Corrected Reading (dBm)	Limit (dBm)	Margin (dB)
1673.2	V	-38.29	-13	-25.29
1673.2	H	-43.68	-13	-30.68
2509.8	V	-34.85	-13	-21.85
2509.8	H	-32.4	-13	-19.4
145.6	V	-49.58	-13	-36.58
369.5	H	-50.26	-13	-37.26

High channel

Frequency (MHz)	Antenna Polarization (H/V)	Corrected Reading (dBm)	Limit (dBm)	Margin (dB)
1697.6	V	-38.95	-13	-25.95
1697.6	H	-43.77	-13	-30.77
2546.4	V	-35.16	-13	-22.16
2546.4	H	-33.16	-13	-20.16
251.3	V	-49.89	-13	-36.89
421.6	H	-50.56	-13	-37.56

Note:

- 1, The testing has been conformed to $10 \times 848.8 \text{MHz} = 8,488 \text{MHz}$
- 2, All other emissions more than 30 dB below the limit
- 3, GSM voice , GPRS and EGPRS mode were investigated. The results above show only the worse cases
- 4, X-Axis, Y-Axis and Z-Axis were investigated. The results above show only the worst case.

PCS Band (Part24E) result

Low channel

Frequency (MHz)	Antenna Polarization (H/V)	Corrected Reading (dBm)	Limit (dBm)	Margin (dB)
3700.4	V	-35.14	-13	-22.14
3700.4	H	-33.62	-13	-20.62
5550.6	V	-34.58	-13	-21.58
5550.6	H	-31.69	-13	-18.69
452.6	V	-46.85	-13	-33.85
255.8	H	-44.15	-13	-31.15

Middle channel

Frequency (MHz)	Antenna Polarization (H/V)	Corrected Reading (dBm)	Limit (dBm)	Margin (dB)
3760	V	-35.93	-13	-22.93
3760	H	-34	-13	-21
5640	V	-35.02	-13	-22.02
5640	H	-32.12	-13	-19.12
331.2	V	-47.95	-13	-34.95
400.5	H	-51.06	-13	-38.06

High channel

Frequency (MHz)	Antenna Polarization (H/V)	Corrected Reading (dBm)	Limit (dBm)	Margin (dB)
3819.6	V	-34.58	-13	-21.58
3819.6	H	-33.26	-13	-20.26
5729.4	V	-34.18	-13	-21.18
5729.4	H	-32.62	-13	-19.62
579.1	V	-45.69	-13	-32.69
356.5	H	-48.95	-13	-35.95

Note:

- 1, The testing has been conformed to $10 \times 1909.8 \text{MHz} = 19,098 \text{MHz}$
- 2, All other emissions more than 30 dB below the limit
- 3, GSM voice , GPRS and EGPRS mode were investigated. The results above show only the worse cases
- 4, X-Axis, Y-Axis and Z-Axis were investigated. The results above show only the worst case.

UMTS-FDD Band V (Part 22H)

Low channel

Frequency (MHz)	Antenna Polarization (H/V)	Corrected Reading (dBm)	Limit (dBm)	Margin (dB)
1648.4	V	-43.16	-13	-30.16
1648.4	H	-45.32	-13	-32.32
199.5	V	-53.62	-13	-40.62
426.3	H	-55.85	-13	-42.85

Middle channel

Frequency (MHz)	Antenna Polarization (H/V)	Corrected Reading (dBm)	Limit (dBm)	Margin (dB)
1673.2	V	-45.06	-13	-32.06
1673.2	H	-46.25	-13	-33.25
220.5	V	-56.41	-13	-43.41
418.9	H	-55.82	-13	-42.82

High channel

Frequency (MHz)	Antenna Polarization (H/V)	Corrected Reading (dBm)	Limit (dBm)	Margin (dB)
1697.6	V	-43.06	-13	-30.06
1697.6	H	-42.58	-13	-29.58
284.6	V	-54.87	-13	-41.87
489.7	H	-56.49	-13	-43.49

Note:

- 1, The testing has been conformed to $10 \times 846.6 \text{MHz} = 8,466 \text{MHz}$
- 2, All other emissions more than 30 dB below the limit
- 3, RMC, HSUPA and HSDPA mode were investigated. The results above show only the worse cases
- 4, X-Axis, Y-Axis and Z-Axis were investigated. The results above show only the worst case.

UMTS-FDD Band II (Part 24E)

Low channel

Frequency (MHz)	Antenna Polarization (H/V)	Corrected Reading (dBm)	Limit (dBm)	Margin (dB)
3700.4	V	-41.26	-13	-28.26
3700.4	H	-42.58	-13	-29.58
199.5	V	-56.84	-13	-43.84
342.5	H	-57.1	-13	-44.1

Middle channel

Frequency (MHz)	Antenna Polarization (H/V)	Corrected Reading (dBm)	Limit (dBm)	Margin (dB)
3760	V	-42.13	-13	-29.13
3760	H	-42.77	-13	-29.77
289.5	V	-57.41	-13	-44.41
225.4	H	-55.12	-13	-42.12

High channel

Frequency (MHz)	Antenna Polarization (H/V)	Corrected Reading (dBm)	Limit (dBm)	Margin (dB)
3819.6	V	-41.99	-13	-28.99
3819.6	H	-42.63	-13	-29.63
615.2	V	-56.15	-13	-43.15
428.9	H	-54.29	-13	-41.29

Note:

- 1, The testing has been conformed to $10 \times 1907.6 \text{ MHz} = 19,076 \text{ MHz}$
- 2, All other emissions more than 30 dB below the limit
- 3, RMC, HSUPA and HSDPA mode were investigated. The results above show only the worse cases
- 4, X-Axis, Y-Axis and Z-Axis were investigated. The results above show only the worst case

6.7 Band Edge

Temperature	23°C
Relative Humidity	66%
Atmospheric Pressure	1013mbar
Test date :	Sep 17,2019
Tested By :	Aaron Liang

Requirement(s):

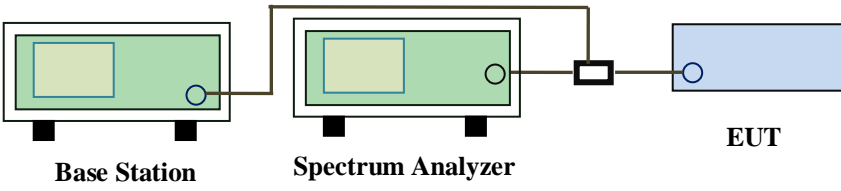
Spec	Item	Requirement	Applicable
§22.917(a) §24.238(a)	a)	The power of any emission outside of the authorized operating frequency ranges must be lower than the transmitter power (P) by a factor of at least $43 + 10 \log (P)$ dB.	<input checked="" type="checkbox"/>
Test setup	 <p>The diagram shows a Base Station (green box) connected to a Spectrum Analyzer (green box) and an EUT (blue box) via a power divider (black box). The Base Station and Spectrum Analyzer are connected to the power divider, which then splits the signal to the EUT.</p>		
Procedure	<ul style="list-style-type: none"> - The EUT was connected to Spectrum Analyzer and Base Station via power divider. - The Band Edges of low and high channels for the highest RF powers were measured. Setting RBW as roughly BW/100. 		
Remark			
Result	<input checked="" type="checkbox"/> Pass <input type="checkbox"/> Fail		

Test Data Yes N/A

Test Plot Yes (See below) N/A

GSM Voice:

Cellular Band (Part 22H) result

Frequency (MHz)	Emission (dBm)	Limit (dBm)
823.996	-16.016	-13
849.027	-17.553	-13

PCS Band (Part24E) result

Frequency (MHz)	Emission (dBm)	Limit (dBm)
1849.98	-15.152	-13
1910.013	-15.522	-13

GPRS:

Cellular Band (Part 22H) result

Frequency (MHz)	Emission (dBm)	Limit (dBm)
822.979	-19.137	-13
849.02	-15.966	-13

PCS Band (Part24E) result

Frequency (MHz)	Emission (dBm)	Limit (dBm)
1849.979	-14.589	-13
1910.01	-14.741	-13

EGPRS (MSC1):

Cellular Band (Part 22H) result

Frequency (MHz)	Emission (dBm)	Limit (dBm)
823.996	-18.428	-13
849.023	-14.833	-13

PCS Band (Part24E) result

Frequency (MHz)	Emission (dBm)	Limit (dBm)
1849.88	-25.148	-13
1910.02	-25.335	-13

RMC:

UMTS-FDD Band V (Part 22H)

Frequency (MHz)	Emission (dBm)	Limit (dBm)
823.99	-16.219	-13
849.01	-21.876	-13

UMTS-FDD Band II (Part 24E)

Frequency (MHz)	Emission (dBm)	Limit (dBm)
1848.43	-24.588	-13
1910.07	-25.069	-13

HSDPA:

UMTS-FDD Band V (Part 22H)

Frequency (MHz)	Emission (dBm)	Limit (dBm)
823.98	-18.984	-13
849.01	-21.876	-13

UMTS-FDD Band II (Part 24E)

Frequency (MHz)	Emission (dBm)	Limit (dBm)
1849.88	-25.148	-13
1910.02	-25.335	-13

HSUPA:

UMTS-FDD Band V (Part 22H)

Frequency (MHz)	Emission (dBm)	Limit (dBm)
823.98	-16.21	-13
849.12	-22.444	-13

UMTS-FDD Band II (Part 24E)

Frequency (MHz)	Emission (dBm)	Limit (dBm)
1848.79	-21.439	-13
1910.05	-25.762	-13

**GSM Voice:
Test Plots**

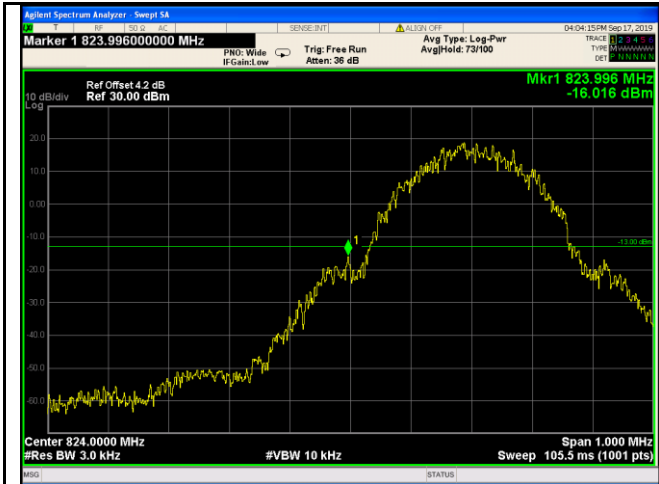

Cellular Band - Low Channel

Note: Offset=Cable loss (4.0) + 10log
(3.15/3)=4.0+0.2=4.2dB



Cellular Band - High Channel

Note: Offset=Cable loss (4.0) + 10log
(3.12/3)=4.0+0.2=4.2dB

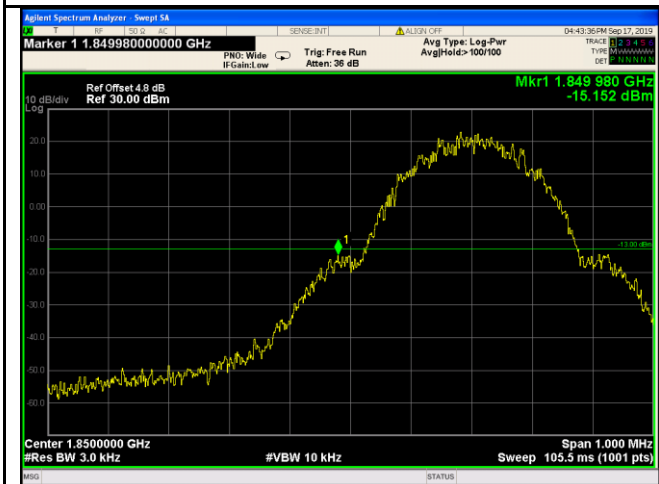

PCS Band - Low Channel

Note: Offset=Cable loss (4.5) + 10log
(3.22/3)=4.5+0.3=4.8dB



PCS Band - High Channel

Note: Offset=Cable loss (4.5) + 10log
(3.15/3)=4.5+0.2=4.7dB

GPRS:

Test Plots

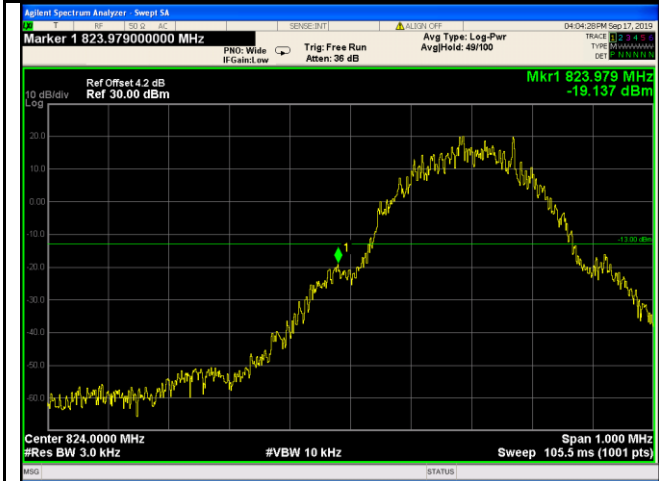

Cellular Band - Low Channel

Note: Offset=Cable loss (4.0) + 10log
 $(3.15/3)=4.0+0.2=4.2\text{dB}$



Cellular Band - High Channel

Note: Offset=Cable loss (4.0) + 10log
 $(3.16/3)=4.0+0.2=4.2\text{dB}$

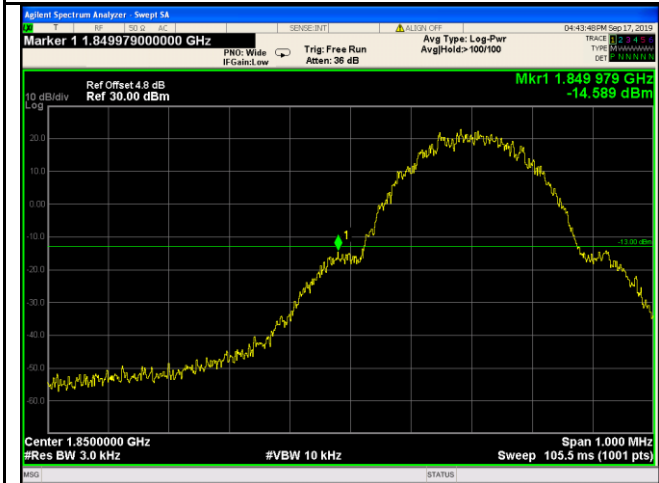

PCS Band - Low Channel

Note: Offset=Cable loss (4.5) + 10log
 $(3.22/3)=4.5+0.3=4.8\text{dB}$



PCS Band - High Channel

Note: Offset=Cable loss (4.5) + 10log
 $(3.15/3)=4.5+0.2=4.7\text{dB}$

EGPRS (MSC1):

Test Plots

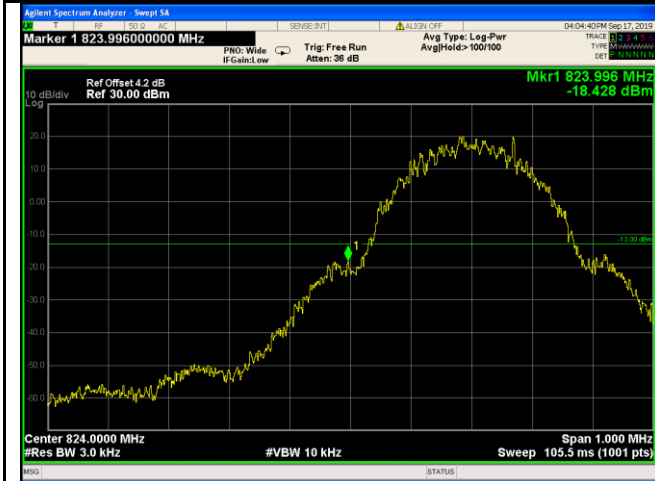

Cellular Band - Low Channel

Note: Offset=Cable loss (4.0) + 10log
(3.20/3)=4.0+0.3=4.3dB



Cellular Band - High Channel

Note: Offset=Cable loss (4.0) + 10log
(3.16/3)=4.0+0.2=4.2dB

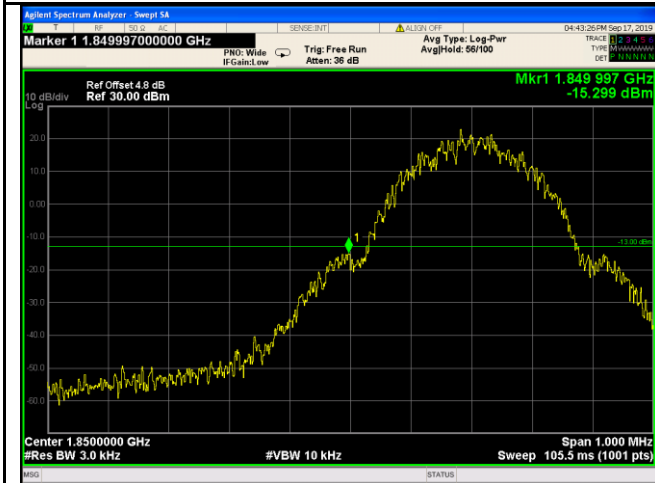

PCS Band - Low Channel

Note: Offset=Cable loss (4.5) + 10log
(3.22/3)=4.5+0.3=4.8dB



PCS Band - High Channel

Note: Offset=Cable loss (4.5) + 10log
(3.15/3)=4.5+0.2=4.7dB

RMC:

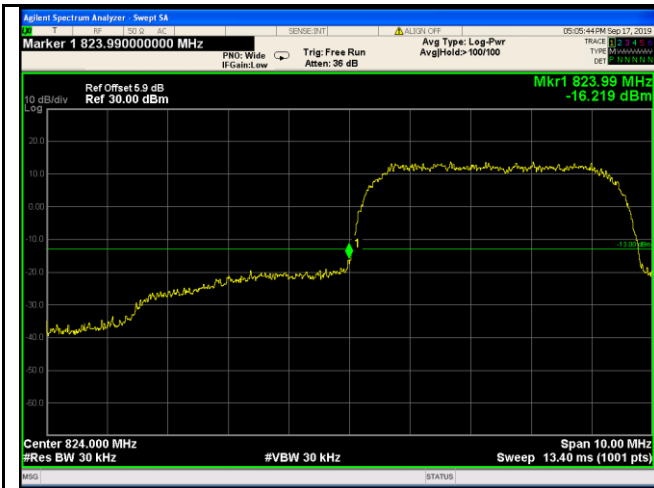

UMTS-FDD Band V - Low Channel

Note: Offset=Cable loss (4.0) + 10log
(47.07/30)=4.0+2.0=6.0dB



UMTS-FDD Band V - High Channel

Note: Offset=Cable loss (4.0) + 10log
(47.00/30)=4.0+1.9 =5.9dB

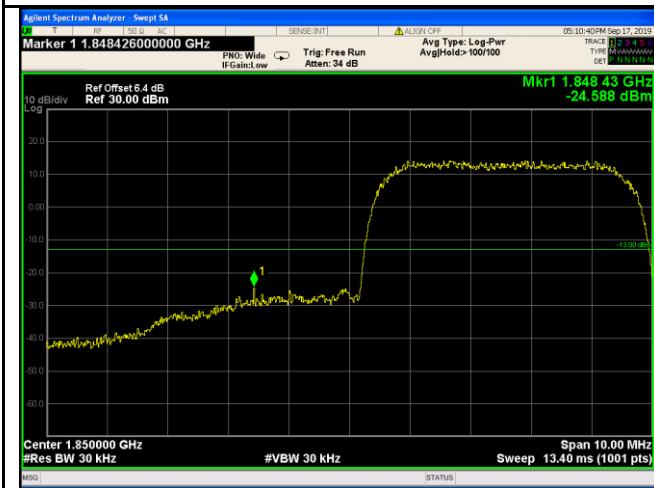

UMTS-FDD Band II - Low Channel

Note: Offset=Cable loss (4.5) + 10log
(46.77/30)=4.5+1.9=6.4dB



UMTS-FDD Band II - High Channel

Note: Offset=Cable loss (4.5) + 10log
(46.79/30)=4.5+1.9=6.4dB

HSDPA:

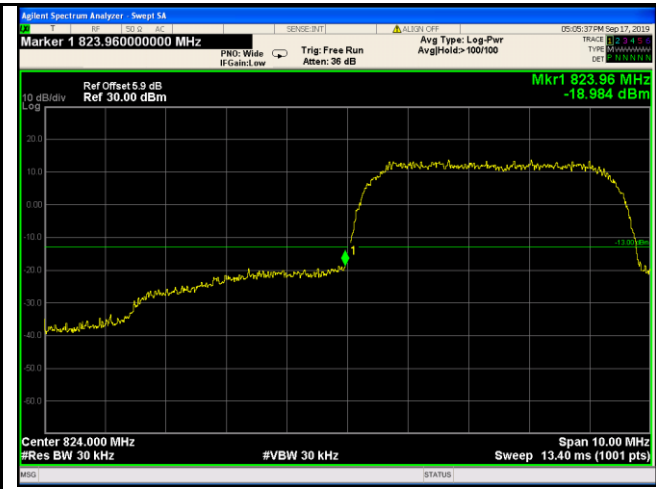

UMTS-FDD Band V - Low Channel

Note: Offset=Cable loss (4.0) + 10log
(46.98/30)=4.0+1.9=5.9dB

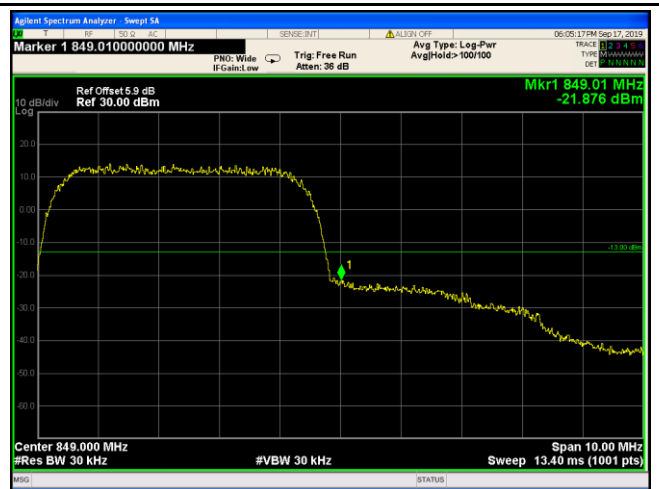

UMTS-FDD Band V - High Channel

Note: Offset=Cable loss (4.0) + 10log
(46.91/30)=4.0+1.9=5.9dB

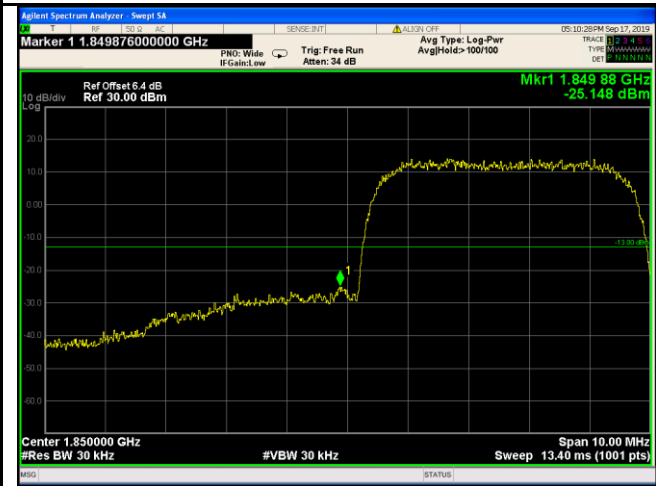

UMTS-FDD Band II - Low Channel

Note: Offset=Cable loss (4.5) + 10log
(46.77/30)=4.5+1.9=6.4dB



UMTS-FDD Band II - High Channel

Note: Offset=Cable loss (4.5) + 10log
(46.76/30)=4.5+1.9=6.4dB

HSUPA:

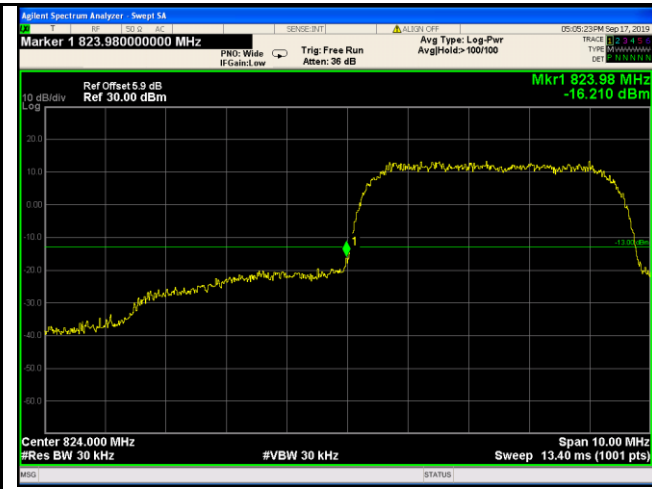

UMTS-FDD Band V - Low Channel

Note: Offset=Cable loss (4.0) + 10log
(46.62/30)=4.0+1.9=5.9dB



UMTS-FDD Band V - High Channel

Note: Offset=Cable loss (4.0) + 10log
(46.81/30)=4.0+1.9=5.9 dB



UMTS-FDD Band II - Low Channel

Note: Offset=Cable loss (4.5) + 10log
(46.88/30)=4.5+1.9=6.4dB



UMTS-FDD Band II - High Channel

Note: Offset=Cable loss (4.5) + 10log
(46.87/30)=4.5+1.9=6.4dB

6.8 Frequency Stability

Temperature	23°C
Relative Humidity	66%
Atmospheric Pressure	1013mbar
Test date :	Sep 17,2019
Tested By :	Aaron Liang

Requirement(s):

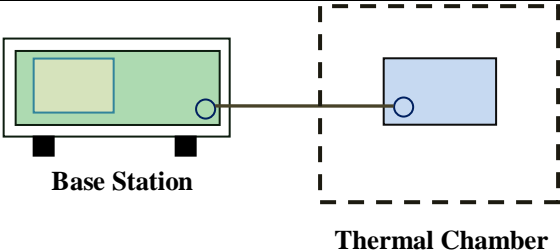
Spec	Item	Requirement	Applicable																																
§2.1055, §22.355 & §24.235	a)	<p>According to §22.355, the carrier frequency of each transmitter in the Public Mobile Services must be maintained within the tolerances given in Table below:</p> <p>Frequency Tolerance for Transmitters in the Public Mobile Services</p> <table border="1"> <thead> <tr> <th>Frequency Range (MHz)</th> <th>Base, fixed (ppm)</th> <th>Mobile ≥ 3 watts (ppm)</th> <th>Mobile ≤ 3 watts (ppm)</th> </tr> </thead> <tbody> <tr> <td>25 to 50</td> <td>20.0</td> <td>20.0</td> <td>50.0</td> </tr> <tr> <td>50 to 450</td> <td>5.0</td> <td>5.0</td> <td>50.0</td> </tr> <tr> <td>45 to 512</td> <td>2.5</td> <td>5.0</td> <td>5.0</td> </tr> <tr> <td>821 to 896</td> <td>1.5</td> <td>2.5</td> <td>2.5</td> </tr> <tr> <td>928 to 929</td> <td>5.0</td> <td>N/A</td> <td>N/A</td> </tr> <tr> <td>929 to 960.</td> <td>1.5</td> <td>N/A</td> <td>N/A</td> </tr> <tr> <td>2110 to 2220</td> <td>10.0</td> <td>N/A</td> <td>N/A</td> </tr> </tbody> </table> <p>According to §24.235, the frequency stability shall be sufficient to ensure that the fundamental emissions stay within the authorized frequency block.</p>	Frequency Range (MHz)	Base, fixed (ppm)	Mobile ≥ 3 watts (ppm)	Mobile ≤ 3 watts (ppm)	25 to 50	20.0	20.0	50.0	50 to 450	5.0	5.0	50.0	45 to 512	2.5	5.0	5.0	821 to 896	1.5	2.5	2.5	928 to 929	5.0	N/A	N/A	929 to 960.	1.5	N/A	N/A	2110 to 2220	10.0	N/A	N/A	<input checked="" type="checkbox"/>
		Frequency Range (MHz)	Base, fixed (ppm)	Mobile ≥ 3 watts (ppm)	Mobile ≤ 3 watts (ppm)																														
25 to 50	20.0	20.0	50.0																																
50 to 450	5.0	5.0	50.0																																
45 to 512	2.5	5.0	5.0																																
821 to 896	1.5	2.5	2.5																																
928 to 929	5.0	N/A	N/A																																
929 to 960.	1.5	N/A	N/A																																
2110 to 2220	10.0	N/A	N/A																																
Test setup		 <p>The diagram shows a green rectangular box labeled 'Base Station' on the left, connected by a horizontal line to a blue rectangular box labeled 'Thermal Chamber' on the right. The 'Thermal Chamber' is enclosed in a dashed-line border.</p>																																	

Procedure	<p>A communication link was established between EUT and base station. The frequency error was monitored and measured by base station under variation of ambient temperature and variation of primary supply voltage.</p> <p>Limit: The frequency stability of the transmitter shall be maintained within $\pm 0.00025\%$ ($\pm 2.5\text{ppm}$) of the center frequency.</p>
Remark	
Result	<input checked="" type="checkbox"/> Pass <input type="checkbox"/> Fail

Test Data Yes N/A

Test Plot Yes (See below) N/A

GSM Voice:

Cellular Band (Part 22H) result

Middle Channel, $f_0 = 836.6$ MHz				
Temperature (°C)	Power Supplied (V _{DC})	Frequency Error (Hz)	Frequency Error (ppm)	Limit (ppm)
-10	3.7	18	0.0215	2.5
0		16	0.0191	2.5
10		16	0.0191	2.5
20		13	0.0155	2.5
30		17	0.0203	2.5
40		14	0.0167	2.5
50		22	0.0263	2.5
55		18	0.0215	2.5
25	4.2	19	0.0227	2.5
	3.5	19	0.0227	2.5

PCS Band (Part 24E) result

Middle Channel, $f_0 = 1880$ MHz				
Temperature (°C)	Power Supplied (V _{DC})	Frequency Error (Hz)	Frequency Error (ppm)	Limit (ppm)
-10	3.7	14	0.0074	2.5
0		14	0.0074	2.5
10		11	0.0059	2.5
20		15	0.0080	2.5
30		17	0.0090	2.5
40		18	0.0096	2.5
50		17	0.0090	2.5
55		17	0.0090	2.5
25	4.2	19	0.0101	2.5
	3.5	22	0.0117	2.5

RMC:

UMTS-FDD Band V (Part 22H)

Middle Channel, $f_o = 835$ MHz				
Temperature (°C)	Power Supplied (V _{DC})	Frequency Error (Hz)	Frequency Error (ppm)	Limit (ppm)
-10	3.7	16	0.0192	2.5
0		16	0.0192	2.5
10		14	0.0168	2.5
20		13	0.0156	2.5
30		12	0.0144	2.5
40		8	0.0096	2.5
50		17	0.0204	2.5
55		14	0.0168	2.5
25	4.2	15	0.0180	2.5
	3.5	15	0.0180	2.5

UMTS-FDD Band II (Part 24E)

Middle Channel, $f_o = 1880$ MHz				
Temperature (°C)	Power Supplied (V _{DC})	Frequency Error (Hz)	Frequency Error (ppm)	Limit (ppm)
-10	3.7	20	0.0106	2.5
0		15	0.0080	2.5
10		15	0.0080	2.5
20		16	0.0085	2.5
30		14	0.0074	2.5
40		16	0.0085	2.5
50		19	0.0101	2.5
55		17	0.0090	2.5
25		4.2	18	0.0096
	3.5	17	0.0090	2.5

Annex A. TEST INSTRUMENT

RE& RSE

Frequency Range Below 1GHz

Equipment	Manufacturer	Model No.	Serial No.	Last Cal.	Next Cal.
EMI Test Receiver	Rohde&Schwarz	ESL6	1300.5001K06-100262-eQ	Apr. 04, 19	Apr. 03, 20
Bilog Antenna	Sunol Sciences	JB6	A110712	Apr. 08, 19	Apr. 07, 20
Active Antenna	CMO-POWER	AL-130	121031	Mar. 27, 19	Mar. 26, 20
Signal Amplifier	HP	8447E	443008	Mar. 28, 19	Mar. 27, 20
3m Semi-anechoic Chamber	SAEMC	9m*6m*6m	N/A	Oct. 18,18	Oct. 17,21
Test Software	EZ-EMC	ICP-03A1	N/A	N/A	N/A

RE& RSE

Frequency Range Above 1GHz

Equipment	Manufacturer	Model No.	Serial No.	Last Cal.	Next Cal.
Spectrum	Agilent	E4446A	MY46180622	8-May-19	7-May-20
MXA signal analyzer	Agilent	N9020A	MY49100060	Mar. 28, 19	Mar. 27, 20
Horn Antenna	COM-POWER	HAH-118	71259	Mar. 22, 19	Mar. 21, 20
Horn Antenna	COM-POWER	HAH-118	71283	Mar. 20, 19	Mar. 19, 20

SHF-EHF Horn	Schwarzbeck	BBHA9170	BBHA9170147	Jun. 30, 19	Jun. 29, 20
SHF-EHF Horn	Schwarzbeck	BBHA9170	BBHA9170242	Jun. 30, 19	Jun. 29, 20
AMPLIFIER	EM Electronic Corporation	EM01G26G	60613	Mar. 28, 19	Mar. 27, 20
AMPLIFIER	Emc Instruments Corporation	Emc012645	980077	Jan. 04, 19	Jan. 03,20
3m Semi-anechoic	SAEMC	9m*6m*6m	N/A	Oct. 18,18	Oct. 17,21
Test Software	EZ-EMC	ICP-03A1	N/A	N/A	N/A

Antenna Port Conducted RF measurement

Equipment	Manufacturer	Model No.	Serial No.	Last Cal.	Next Cal.
Wireless Connectivity	R&S	CMW270	1201.0002K75	Nov. 29, 18	Nov. 28, 19
MXA VEXTOR SIGNAL	Agilent	n5182a	MY50140530	Mar. 28,19	Mar. 27,20
MXA signal analyzer	Agilent	n9020a	MY49100060	Mar. 28,19	Mar. 27,20
RF Control Unit	Tonscend	JS0806-2	188060112	Mar. 28,19	Mar. 27,20
Signal Generation	Agilent	E4421B	US40051152	Nov. 29, 18	Nov. 28, 19
DC Power Supply	Agilent	E3640A	MY40004013	Mar. 28,19	Mar. 27,20
Programmable Temperature &	Hongjin	HYC-TH-225DH	DG-180746	Mar. 28,19	Mar. 27,20

Test System	Tonscend	JS 1120-3	N/A	N/A	N/A
Power Splitter	Weinschel	1580-1	TL177	Mar. 20,19	Mar. 19,20
Universal Radio Communication	ROHDE&SCHWARZ	CMU200	112012	Mar. 28,19	Mar. 27,20
Universal Radio Communication	ROHDE&SCHWARZ	CMU200	121393	Mar. 28,19	Mar. 27,20
Wireless Communication Test Set	ROHDE&SCHWARZ	CMW500	1201.0002K500-155842-Gd	Aug. 06, 19	Aug. 05, 20

Annex B. TEST SETUP AND SUPPORTING EQUIPMENT

Annex B.i. TEST SET UP BLOCK

Block Configuration Diagram for Radiated Emissions

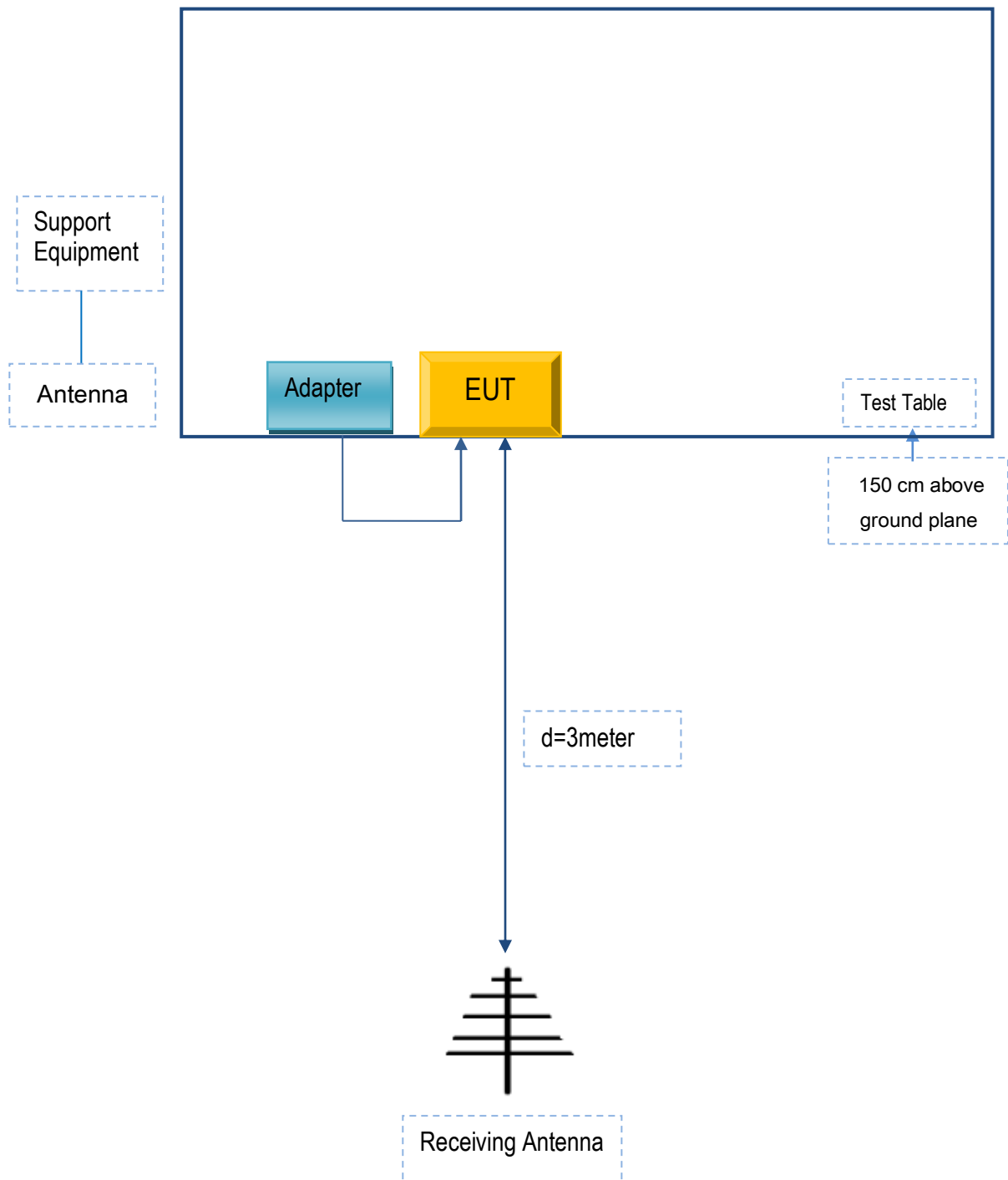

Annex C. SUPPORTING EQUIPMENT DESCRIPTION

The following is a description of supporting equipment and details of cables used with the EUT.

Supporting Equipment:

Manufacturer	Equipment Description	Model	Serial No
N/A	N/A	N/A	N/A

Supporting Cable:

Cable type	Shield Type	Ferrite Core	Length	Serial No
N/A	N/A	N/A	N/A	N/A

Test Report	Q190826S004 -FCC-R1
Page	77 of 77

**Annex C. User Manual / Block Diagram / Schematics / Partlist/
DECLARATION OF SIMILARITY**

Please see the attachment