



# FCC RADIO TEST REPORT

## FCC ID: 2AKQTSMARTBOX

**Product :** TV BOX

**Trade Name :** N/A

**Model Name:** Smartbox

**Serial Model :** G1, G1 pro, G8, G9, C96, T95U pro, MXQ,  
MXQ pro

**Report No. :** POCE- 20161204131R

### Prepared for

Shenzhen B2GO Technology Company Limited  
2201-2203, China South Development Center, China South City,  
Pinghu, LongGang District, Shenzhen, China 518111

### Prepared by

Shenzhen POCE Technology Co.,Ltd.  
Room 502, Bldg. 1, Xinghua Garden, Baoan Road Xixiang,  
Baoan District, Shenzhen, China

### TEST RESULT CERTIFICATION

**Applicant's name** ..... : Shenzhen B2GO Technology Company Limited  
**Address** ..... : 2201-2203, China South Development Center, China South City, Pinghu, LongGang District, Shenzhen, China 518111  
**Manufacture's Name**..... : Shenzhen B2GO Technology Company Limited  
**Address** ..... : 2201-2203, China South Development Center, China South City, Pinghu, LongGang District, Shenzhen, China 518111

**Product description**

**Product name** ..... : TV BOX  
**Model and/or type reference** : Smartbox  
**Serial Model** ..... : G1, G1 pro, G8, G9, C96, T95U pro, MXQ, MXQ pro  
**Standards** ..... : FCC Part15.247, KDB558074 D01 DTS Meas Guidance v03r03  
**Test procedure** ..... ANSI C63.10-2013

This device described above has been tested by POCE, and the test results show that the equipment under test (EUT) is in compliance with the FCC requirements. And it is applicable only to the tested sample identified in the report.

This report shall not be reproduced except in full, without the written approval of POCE, this document may be altered or revised by POCE, personal only, and shall be noted in the revision of the document.

**Date of Test** ..... :  
**Date (s) of performance of tests** ..... : 12 Dec. 2016 ~20 Dec. 2016  
**Date of Issue**..... : 20 Dec. 2016  
**Test Result**..... : **Pass**

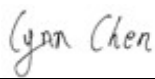
Testing Engineer :   
(Lynn Chen)

Technical Manager :   
(Carlen Liu)

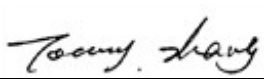
Authorized Signatory :   
(Tommy Zhang)

**Table of Contents**

	<b>Page</b>
<b>1 . SUMMARY OF TEST RESULTS</b>	<b>5</b>
1.1 TEST FACILITY	6
1.2 MEASUREMENT UNCERTAINTY	6
<b>2 . GENERAL INFORMATION</b>	<b>7</b>
2.1 GENERAL DESCRIPTION OF EUT	7
2.2 DESCRIPTION OF TEST MODES	10
2.3 BLOCK DIGRAM SHOWING THE CONFIGURATION OF SYSTEM TESTED	11
2.4 DESCRIPTION OF SUPPORT UNITS(CONDUCTED MODE)	12
2.5 EQUIPMENTS LIST FOR ALL TEST ITEMS	13
<b>3 . EMC EMISSION TEST</b>	<b>14</b>
3.1 CONDUCTED EMISSION MEASUREMENT	14
3.1.1 POWER LINE CONDUCTED EMISSION LIMITS	14
3.1.2 TEST PROCEDURE	15
3.1.3 DEVIATION FROM TEST STANDARD	15
3.1.4 TEST SETUP	15
3.1.5 EUT OPERATING CONDITIONS	15
3.1.6 TEST RESULTS	16
3.2 RADIATED EMISSION MEASUREMENT	18
3.2.1 RADIATED EMISSION LIMITS	18
3.2.2 TEST PROCEDURE	19
3.2.3 DEVIATION FROM TEST STANDARD	19
3.2.4 TEST SETUP	20
3.2.5 EUT OPERATING CONDITIONS	21
3.2.6 TEST RESULTS (BETWEEN 9KHZ – 30 MHZ)	22
3.2.7 TEST RESULTS (BETWEEN 30MHZ – 1GHZ)	23
3.2.8 TEST RESULTS (ABOVE 1000 MHZ)	25
<b>4 . POWER SPECTRAL DENSITY TEST</b>	<b>55</b>
4.1 APPLIED PROCEDURES / LIMIT	55
4.1.1 TEST PROCEDURE	55
4.1.2 DEVIATION FROM STANDARD	55
4.1.3 TEST SETUP	55
4.1.4 EUT OPERATION CONDITIONS	55
4.1.5 TEST RESULTS	56
<b>5 . BANDWIDTH TEST</b>	<b>64</b>
5.1 APPLIED PROCEDURES / LIMIT	64

**Table of Contents**

	<b>Page</b>
5.1.1 TEST PROCEDURE	64
5.1.2 DEVIATION FROM STANDARD	64
5.1.3 TEST SETUP	64
5.1.4 EUT OPERATION CONDITIONS	64
5.1.5 TEST RESULTS	65
<b>6 . PEAK OUTPUT POWER TEST</b>	<b>73</b>
6.1 APPLIED PROCEDURES / LIMIT	73
6.1.1 TEST PROCEDURE	73
6.1.2 DEVIATION FROM STANDARD	73
6.1.3 TEST SETUP	73
6.1.4 EUT OPERATION CONDITIONS	73
6.1.5 TEST RESULTS	74
<b>7 . ANTENNA REQUIREMENT</b>	<b>75</b>
7.1 STANDARD REQUIREMENT	75
7.2 EUT ANTENNA	75
<b>APPENDIX-PHOTOGRAPHS OF EUT CONSTRUCTIONAL DETAILS</b>	

## 1. SUMMARY OF TEST RESULTS

Test procedures according to the technical standards:

<b>FCC Part15 (15.247) , Subpart C RSS-210 Annex 8</b>			
<b>Standard Section</b>	<b>Test Item</b>	<b>Judgment</b>	<b>Remark</b>
15.207&7.2.4	Conducted Emission	PASS	
15.247 (a)(2) & A8.2	6dB Bandwidth	PASS	
15.247 (b) & A8.4	Peak Output Power	PASS	
15.247 (c) &A8.5	Radiated Spurious Emission	PASS	
15.247 (d) & A8.2	Power Spectral Density	PASS	
15.205&A8.5	Band Edge Emission	PASS	
15.203	Antenna Requirement	PASS	

**NOTE:**

(1) " N/A " denotes test is not applicable in this Test Report

## 1.1 TEST FACILITY

Shenzhen POCE Technology Co.,Ltd.

Add.: Room 502, Bldg. 1, Xinghua Garden, Baoan Road Xixiang, Baoan District, Shenzhen, China

FCC Registration No.: 222278

## 1.2 MEASUREMENT UNCERTAINTY

The reported uncertainty of measurement  $y \pm U$ , where expanded uncertainty  $U$  is based on a standard uncertainty multiplied by a coverage factor of  $k=2$ , providing a level of confidence of approximately **95 %**.

No.	Item	Uncertainty
1	Conducted Emission Test	$\pm 1.38\text{dB}$
2	RF power,conducted	$\pm 0.16\text{dB}$
3	Spurious emissions,conducted	$\pm 0.21\text{dB}$
4	All emissions,radiated(<1G)	$\pm 4.68\text{dB}$
5	All emissions,radiated(>1G)	$\pm 4.89\text{dB}$
6	Temperature	$\pm 0.5^{\circ}\text{C}$
7	Humidity	$\pm 2\%$

## 2. GENERAL INFORMATION

### 2.1 GENERAL DESCRIPTION OF EUT

Equipment	TV BOX	
Trade Name	N/A	
Model Name	Smartbox	
Serial Model	G1, G1 pro, G8, G9, C96, T95U pro, MXQ, MXQ pro	
Model Difference	All the model are the same circuit and RF module, except the model name	
Product Description	The EUT is a TV BOX	
	Operation Frequency:	2412~2462 MHz
	Modulation Type:	DSS ( BPSK / QPSK / CCK) for 802.11b, OFDM (BPSK / QPSK / 16QAM / 64QAM ) for 802.11g/n
	Bit Rate of Transmitter	802.11b:11/5.5/2/1 Mbps 802.11g:54/48/36/24/18/12/9/6Mbps 802.11n(20MHz):150/144.44/130/117/115.56/104/86.67/78/52/6.5 Mbps 802.11n(40MHz):300/270/240/180/150/120/108/90/54 Mbps
	Number Of Channel	11 CH, Please see Note 2.
	Antenna Designation:	Please see Note 3.
	Output Power(Conducted):	802.11b: 21.56 dbm(Mxa) 802.11g: 19.87 dBm (Max.) 802.11n(20M) : 23.34 dBm (Max.) 802.11n(40M) : 22.77dBm (Max.)
	Antenna Gain (dBi)	1.0dbi
	Based on the application, features, or specification exhibited in User's Manual, the EUT is considered as an ITE/Computing Device. More details of EUT technical specification, please refer to the User's Manual.	
Channel List	Please refer to the Note 2.	
Ratings	DC 5V from Adapter	
Adapter	Model:XY-AP05020AHL Input: 100-240V~, 50/60Hz Output: 5.0V $\equiv$ 2A	
Battery	N/A	
Connecting I/O Port(s)	Please refer to the User's Manual	

Note:

1. For a more detailed features description, please refer to the manufacturer's specifications or the User's Manual.

2.

Channel List for 802.11b/g/n(20MHz)							
Channel	Frequency (MHz)	Channel	Frequency (MHz)	Channel	Frequency (MHz)	Channel	Frequency (MHz)
01	2412	04	2427	07	2442	10	2457
02	2417	05	2432	08	2447	11	2462
03	2422	06	2437	09	2452		

Channel List for 802.11n(40MHz)							
Channel	Frequency (MHz)	Channel	Frequency (MHz)	Channel	Frequency (MHz)	Channel	Frequency (MHz)
03	2422	06	2437	09	2452		
04	2427	07	2442				
05	2432	08	2447				



3.

Table for Filed Antenna

Ant	Brand	Model Name	Antenna Type	Gain (dBi)	NOTE
A	N/A	N/A	external antenna	1.0	N/A
B	N/A	N/A	external antenna	1.0	N/A

The Control software(MP\_TEST.exe) can control antenna A, antenna B. The antenna A and B can simultaneously transmit. The antenna is 2T2R. And the data is recorded for radiated spurious emission and band edge emission.

In 802.11b/g mode, When the antenna A is on, antenna B is off. When Antenna B is on, antenna A is off.

In 802.11n20/n40 mode, antenna A, B can simultaneously transmit.

Close PC(MP\_TEST.exe), this device will still in the transmit state



## 2.2 DESCRIPTION OF TEST MODES

To investigate the maximum EMI emission characteristics generates from EUT, the test system was pre-scanning tested base on the consideration of following EUT operation mode or test configuration mode which possible have effect on EMI emission level. Each of these EUT operation mode(s) or test configuration mode(s) mentioned above was evaluated respectively.

Pretest Mode	Description
Mode 1	802.11b CH1/ CH6/ CH11
Mode 2	802.11g CH1/ CH6/ CH11
Mode 3	802.11n(20) CH1/ CH6/ CH11
Mode 4	802.11n(40) CH3/ CH6/ CH9
Mode 5	WIFI NORMAL LINK

For Conducted Emission	
Final Test Mode	Description
Mode 5	WIFI NORMAL LINK

For Radiated Emission	
Final Test Mode	Description
Mode 1	802.11b CH1/ CH6/ CH11
Mode 2	802.11g CH1/ CH6/ CH11
Mode 3	802.11n(20) CH1/ CH6/ CH11
Mode 4	802.11n(40) CH3/ CH6/ CH9
Mode 5	WIFI NORMAL LINK

Note:

- (1) The measurements are performed at the highest, middle, lowest available channels.
- (2) The measurements are performed at all Bit Rate of Transmitter, the worst data was reported

### 2.3 BLOCK DIGRAM SHOWING THE CONFIGURATION OF SYSTEM TESTED

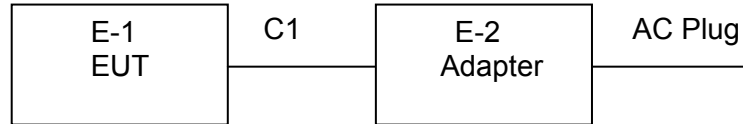

**2.4 DESCRIPTION OF SUPPORT UNITS(CONDUCTED MODE)**

The EUT has been tested as an independent unit together with other necessary accessories or support units. The following support units or accessories were used to form a representative test configuration during the tests.

Item	Equipment	Mfr/Brand	Model/Type No.	Series No.	Note
E-1	TV BOX	N/A	Smartbox	N/A	EUT
E-2	Adapter	N/A	XY-AP05020AHL	N/A	

Item	Shielded Type	Ferrite Core	Length	Note
C-1	NO	NO	1.0M	

Note:

- (1) The support equipment was authorized by Declaration of Confirmation.
- (2) For detachable type I/O cable should be specified the length in cm in 『Length』 column.

## 2.5 EQUIPMENTS LIST FOR ALL TEST ITEMS

### Radiation Test equipment

Item	Kind of Equipment	Manufacturer	Type No.	Serial No.	Last calibration	Calibrated until	Calibration period
1	Spectrum Analyzer	Agilent	E4407B	MY45108040	2016.07.06	2017.07.05	1 year
2	Test Receiver	R&S	ESPI	101318	2016.06.07	2017.06.06	1 year
3	Bilog Antenna	TESEQ	CBL6111D	31216	2016.07.06	2017.07.05	1 year
4	50Ω Coaxial Switch	Anritsu	MP59B	6200264416	2016.06.07	2017.06.06	1 year
5	Spectrum Analyzer	ADVANTEST	R3132	150900201	2016.06.07	2017.06.06	1 year
6	Horn Antenna	EM	EM-AH-10180	2011071402	2016.07.06	2017.07.05	1 year
7	Horn Ant	Schwarzbeck	BBHA 9170	9170-181	2016.07.06	2017.07.05	1 year
8	Amplifier	EM	EM-30180	060538	2015.12.22	2016.12.21	1 year
9	Loop Antenna	ARA	PLA-1030/B	1029	2016.06.08	2017.06.07	1 year

### Conduction Test equipment

Item	Kind of Equipment	Manufacturer	Type No.	Serial No.	Last calibration	Calibrated until	Calibration period
1	Test Receiver	R&S	ESCI	101160	2016.06.06	2017.06.05	1 year
2	LISN	R&S	ENV216	101313	2016.08.24	2017.08.23	1 year
3	LISN	EMCO	3816/2	00042990	2016.08.24	2017.08.23	1 year
4	50Ω Coaxial Switch	Anritsu	MP59B	6200264417	2016.06.07	2017.06.06	1 year
5	Passive Voltage Probe	R&S	ESH2-Z3	100196	2016.06.07	2017.06.06	1 year
6	Absorbing clamp	R&S	MOS-21	100423	2016.06.08	2017.06.07	1 year

### 3. EMC EMISSION TEST

#### 3.1 CONDUCTED EMISSION MEASUREMENT

##### 3.1.1 POWER LINE CONDUCTED EMISSION Limits (Frequency Range 150KHz-30MHz)

FREQUENCY (MHz)	Class A (dBuV)		Class B (dBuV)		Standard
	Quasi-peak	Average	Quasi-peak	Average	
0.15 -0.5	79.00	66.00	66 - 56 *	56 - 46 *	CISPR
0.50 -5.0	73.00	60.00	56.00	46.00	CISPR
5.0 -30.0	73.00	60.00	60.00	50.00	CISPR

0.15 -0.5	79.00	66.00	66 - 56 *	56 - 46 *	FCC
0.50 -5.0	73.00	60.00	56.00	46.00	FCC
5.0 -30.0	73.00	60.00	60.00	50.00	FCC

Note:

- (1) The tighter limit applies at the band edges.
- (2) The limit of " \* " marked band means the limitation decreases linearly with the logarithm of the frequency in the range.

The following table is the setting of the receiver

Receiver Parameters	Setting
Attenuation	10 dB
Start Frequency	0.15 MHz
Stop Frequency	30 MHz
IF Bandwidth	9 kHz

**3.1.2 TEST PROCEDURE**

- a. The EUT was placed 0.4 meters from the horizontal ground plane with EUT being connected to the power mains through a line impedance stabilization network (LISN). All other support equipments powered from additional LISN(s). The LISN provide 50 Ohm/ 50uH of coupling impedance for the measuring instrument.
- b. Interconnecting cables that hang closer than 40 cm to the ground plane shall be folded back and forth in the center forming a bundle 30 to 40 cm long.
- c. I/O cables that are not connected to a peripheral shall be bundled in the center. The end of the cable may be terminated, if required, using the correct terminating impedance. The overall length shall not exceed 1 m.
- d. LISN at least 80 cm from nearest part of EUT chassis.
- e. For the actual test configuration, please refer to the related Item –EUT Test Photos.

**3.1.3 DEVIATION FROM TEST STANDARD**

No deviation

**3.1.4 TEST SETUP**

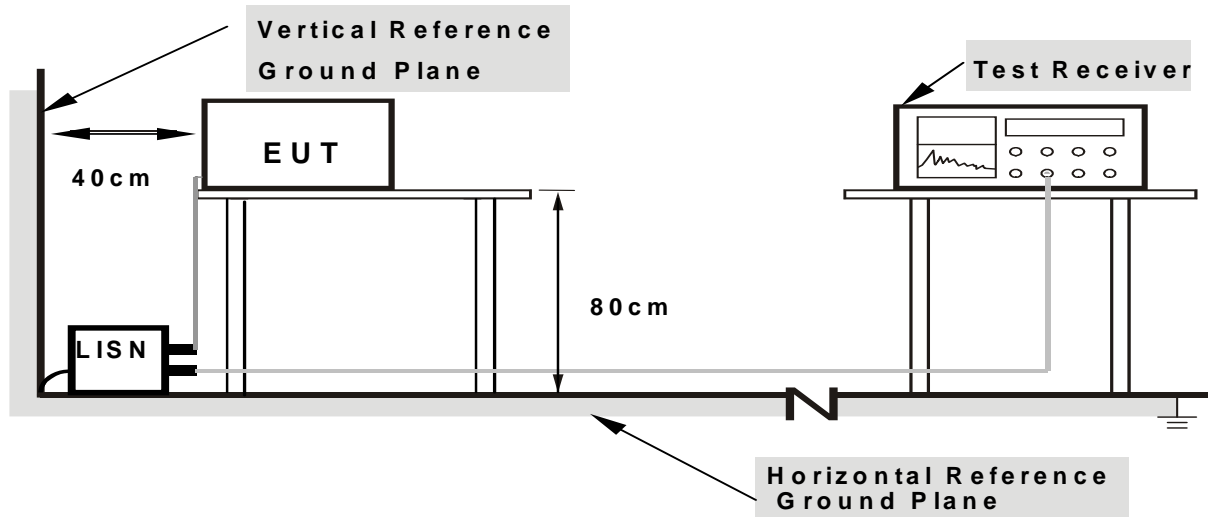

- Note:**
- 1. Support units were connected to second LISN.
  - 2. Both of LISNs (AMN) are 80 cm from EUT and at least 80 from other units and other metal planes

**3.1.5 EUT OPERATING CONDITIONS**

The EUT was configured for testing in a typical fashion (as a customer would normally use it). The EUT has been programmed to continuously transmit during test. This operating condition was tested and used to collect the included data.

### 3.1.6 TEST RESULTS

EUT :	TV BOX	Model Name. :	Smartbox
Temperature :	26 °C	Relative Humidity :	54%
Pressure :	1010hPa	Phase :	L
Test Voltage :	DC 5V from adapter AC 120V/60Hz	Test Mode :	Mode 5

Frequency (MHz)	Meter Reading (dBμV)	Factor (dB)	Emission Level (dBμV)	Limits (dBμV)	Margin (dB)	Detector Type
0.21	47.05	9.78	56.83	63.2	-6.37	QP
0.21	41.19	9.78	50.97	53.2	-2.23	AVG
0.294	36.75	9.9	46.65	50.41	-3.76	AVG
0.55	27.67	10.2	37.87	46	-8.13	AVG
0.558	37.58	10.2	47.78	56	-8.22	QP
24.93	40.33	10.57	50.9	60	-9.1	QP

**Remark:**

1. All readings are Quasi-Peak and Average values.
2. Factor = Insertion Loss + Cable Loss.

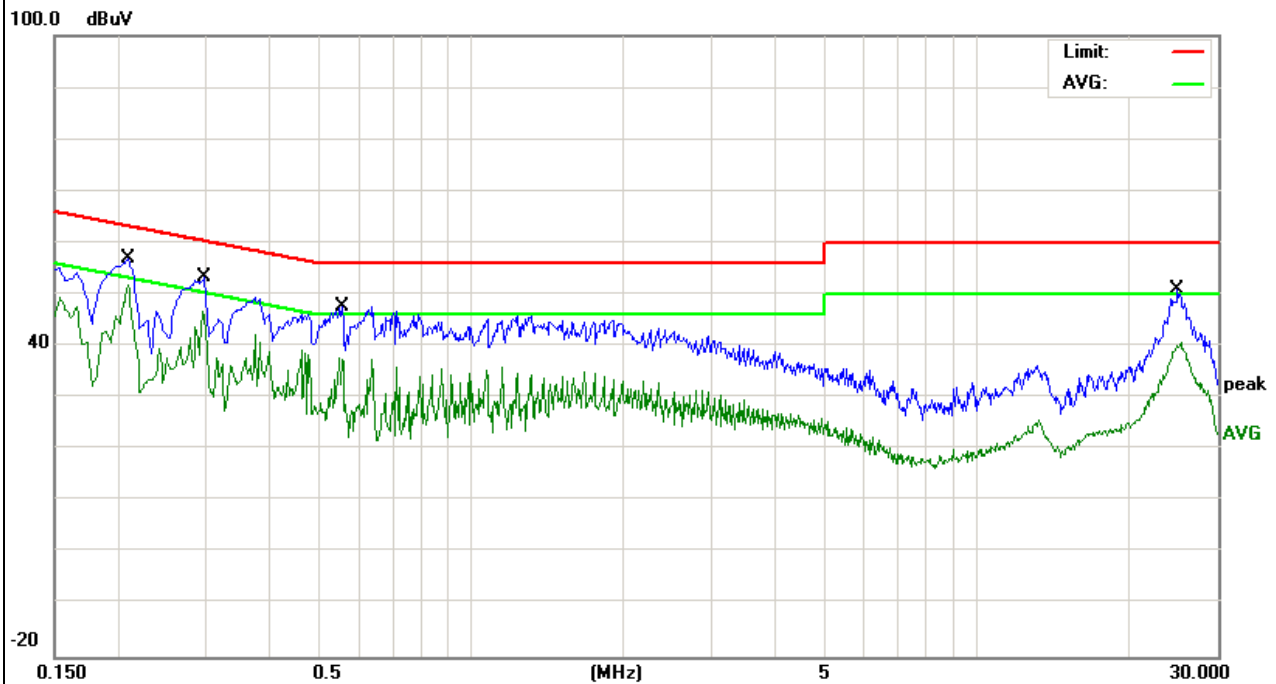



EUT :	TV BOX	Model Name. :	Smartbox
Temperature :	26 °C	Relative Humidity :	54%
Pressure :	1010hPa	Phase :	N
Test Voltage :	DC 5V from adapter AC 120V/60Hz	Test Mode :	Mode 5

Frequency (MHz)	Meter Reading (dBμV)	Factor (dB)	Emission Level (dBμV)	Limits (dBμV)	Margin (dB)	Detector Type
0.162	41.5	9.91	51.41	55.36	-3.95	AVG
0.2028	47.87	10.2	58.07	63.49	-5.42	QP
0.79	29.13	10.22	39.35	46	-6.65	AVG
0.962	39.93	10.16	50.09	56	-5.91	QP
24.938	31.32	10.53	41.85	50	-8.15	AVG
25.114	41.71	10.53	52.24	60	-7.76	QP

Remark:

1. All readings are Quasi-Peak and Average values.
2. Factor = Insertion Loss + Cable Loss.

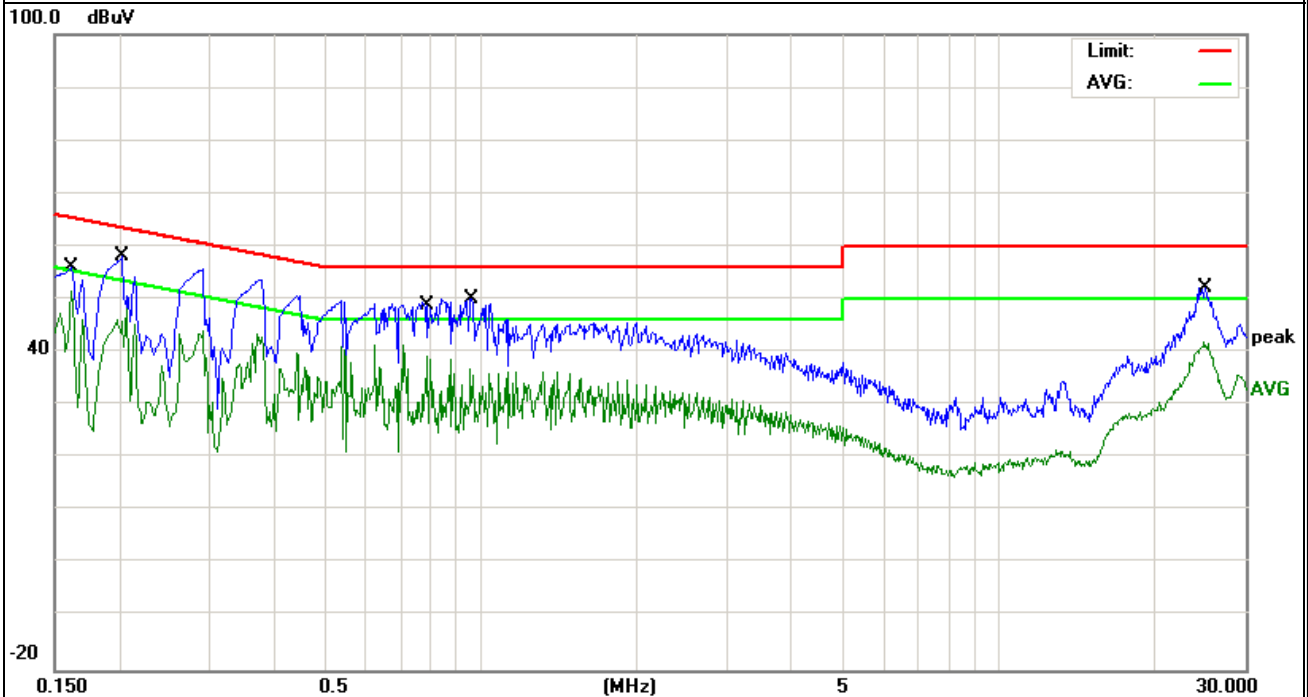

### 3.2 RADIATED EMISSION MEASUREMENT

#### 3.2.1 RADIATED EMISSION LIMITS (Frequency Range 9kHz-1000MHz)

20dBc in any 100 kHz bandwidth outside the operating frequency band. In case the emission fall within the restricted band specified on 15.205(a), then the 15.209(a) limit in the table below has to be followed.

Frequencies (MHz)	Field Strength (micorvolts/meter)	Measurement Distance (meters)
0.009~0.490	2400/F(KHz)	300
0.490~1.705	24000/F(KHz)	30
1.705~30.0	30	30
30~88	100	3
88~216	150	3
216~960	200	3
Above 960	500	3

Spectrum Parameter	Setting
Attenuation	Auto
Start Frequency	1000 MHz
Stop Frequency	10th carrier harmonic
RB / VB (emission in restricted band)	1 MHz / 1 MHz for Peak, 1 MHz / 10Hz for Average

Receiver Parameter	Setting
Attenuation	Auto
Start ~ Stop Frequency	9kHz~150kHz / RB 200Hz for QP
Start ~ Stop Frequency	150kHz~30MHz / RB 9kHz for QP
Start ~ Stop Frequency	30MHz~1000MHz / RB 120kHz for QP

### **3.2.2 TEST PROCEDURE**

- a. The measuring distance of at 3 m shall be used for measurements at frequency up to 1GHz. For frequencies above 1GHz, any suitable measuring distance may be used.
- b. The EUT was placed on the top of a rotating table 0.8 meters(above 1GHz is 1.5 m) above the ground at a 3 meter open area test site. The table was rotated 360 degrees to determine the position of the highest radiation.
- c. The height of the equipment or of the substitution antenna shall be 0.8 m; the height of the test antenna shall vary between 1 m to 4 m. Both horizontal and vertical polarizations of the antenna are set to make the measurement.
- d. The initial step in collecting conducted emission data is a spectrum analyzer peak detector mode pre-scanning the measurement frequency range. Significant peaks are then marked and then Quasi Peak detector mode re-measured.
- e. If the Peak Mode measured value compliance with and lower than Quasi Peak Mode Limit, the EUT shall be deemed to meet QP Limits and then no additional QP Mode measurement performed.
- f. For the actual test configuration, please refer to the related Item –EUT Test Photos.

Note:

Both horizontal and vertical antenna polarities were tested and performed pretest to three orthogonal axis. The worst case emissions were reported

### **3.2.3 DEVIATION FROM TEST STANDARD**

No deviation

### 3.2.4 TEST SETUP

#### (A) Radiated Emission Test-Up Frequency Below 30MHz

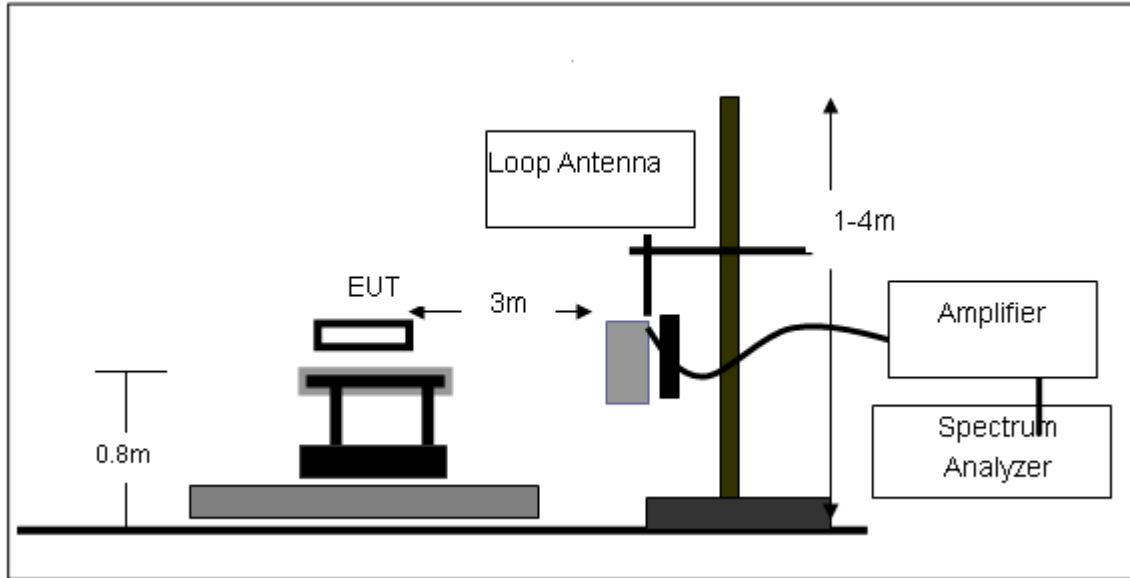

#### (B) Radiated Emission Test-Up Frequency 30MHz~1GHz

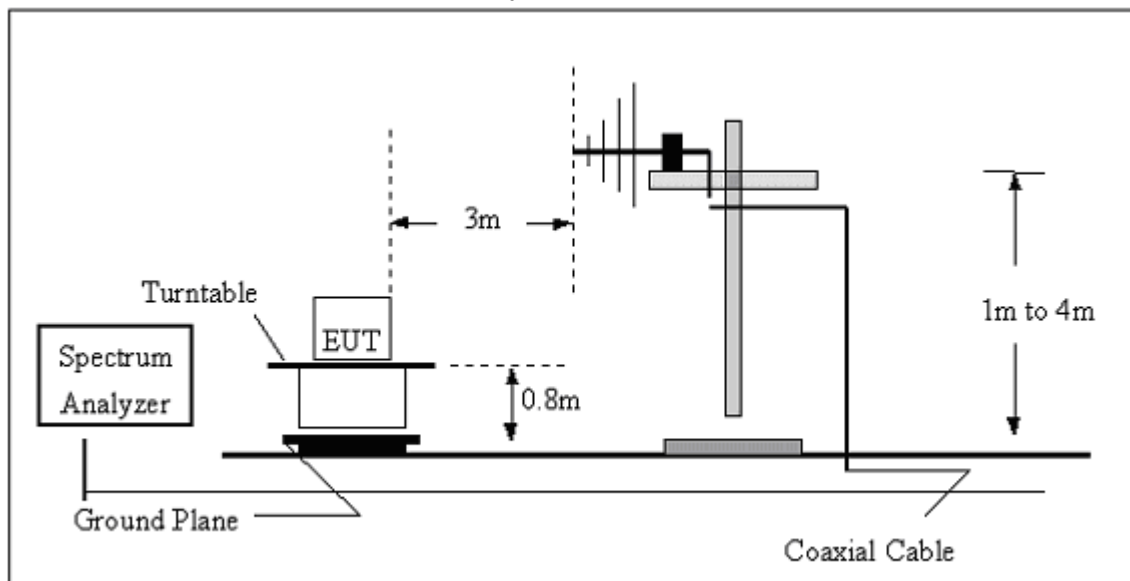

(C) Radiated Emission Test-Up Frequency Above 1GHz

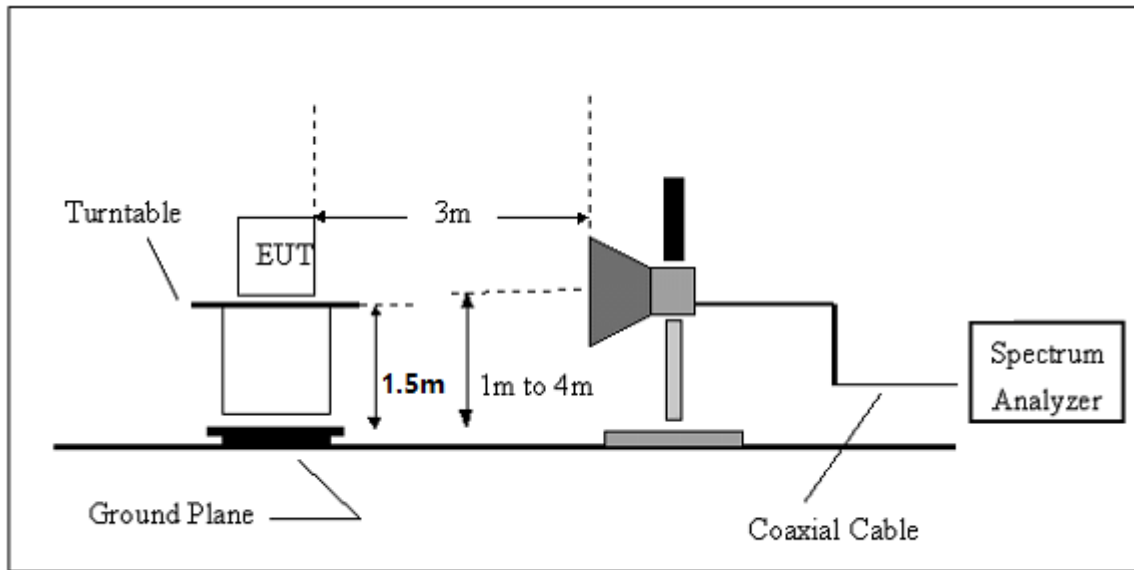

**3.2.5 EUT OPERATING CONDITIONS**

The EUT tested system was configured as the statements of 2.4 Unless otherwise a special operating condition is specified in the follows during the testing.

**3.2.6 TEST RESULTS (BETWEEN 9KHZ – 30 MHZ)**

EUT:	TV BOX	Model Name. :	Smartbox
Temperature:	20 °C	Relative Humidity:	48%
Pressure:	1010 hPa	Test Voltage :	DC 5V from adapter AC 120V/60Hz
Test Mode :	Mode 5	Polarization :	--

Freq.	Reading	Limit	Margin	State
(MHz)	(dBuV/m)	(dBuV/m)	(dB)	P/F
--	--	--	--	PASS
--	--	--	--	PASS

**NOTE:**

The amplitude of spurious emissions which are attenuated by more than 20dB below the permissible value has no need to be reported.

Distance extrapolation factor =  $40 \log (\text{specific distance}/\text{test distance})(\text{dB})$ ;

Limit line = specific limits(dBuv) + distance extrapolation factor.

### 3.2.7 TEST RESULTS (BETWEEN 30MHZ – 1GHZ)

EUT :	TV BOX	Model Name :	Smartbox
Temperature :	20 °C	Relative Humidity :	48%
Pressure :	1010 hPa	Test Voltage :	DC 5V from adapter AC 120V/60Hz
Test Mode :	Mode 5	Polarization :	Horizontal

Frequency (MHz)	Meter Reading (dBµV)	Factor (dB)	Emission Level (dBµV/m)	Limits (dBµV/m)	Margin (dB)	Detector Type
125.0066	27.74	11.9	39.64	43.5	-3.86	QP
183.2005	25.57	9.47	35.04	43.5	-8.46	QP
248.5517	27.07	12.83	39.9	46	-6.1	QP
383.9318	18.5	16.6	35.1	46	-10.9	QP
501.1788	20.36	19.43	39.79	46	-6.21	QP
890.7278	16.17	25.33	41.5	46	-4.5	QP

Remark:

Factor = Antenna Factor + Cable Loss – Pre-amplifier.

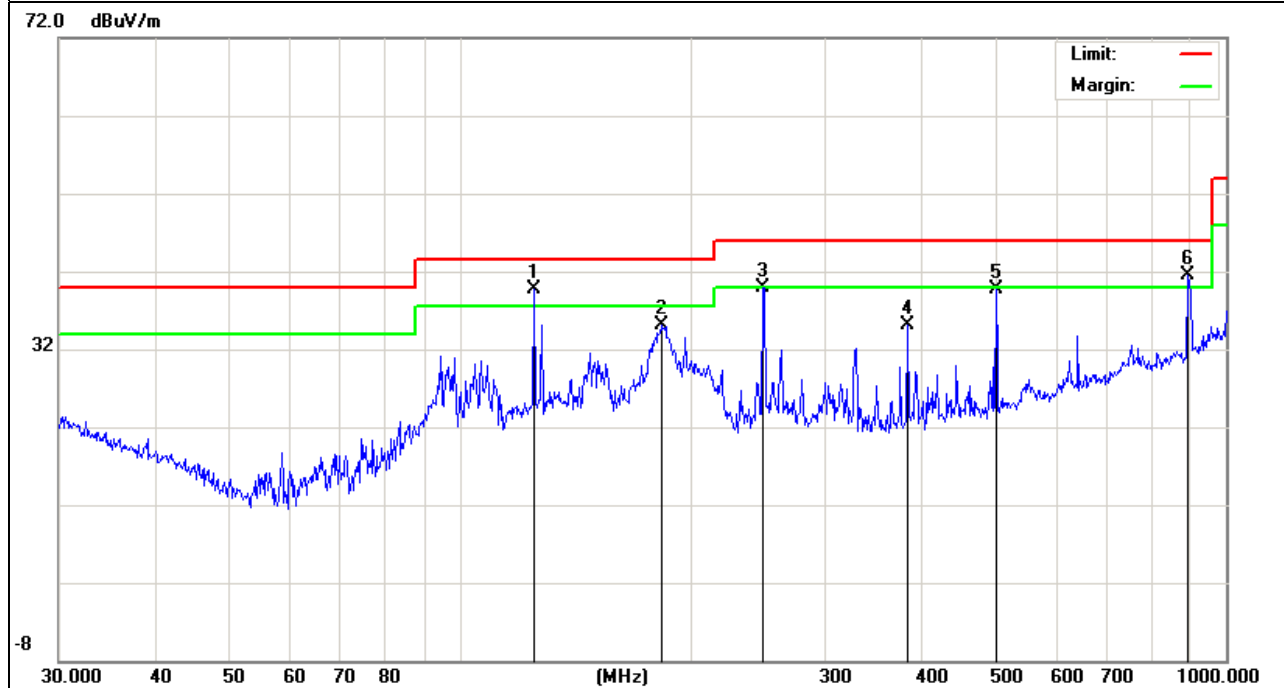

EUT :	TV BOX	Model Name :	Smartbox
Temperature :	20 °C	Relative Humidity :	48%
Pressure :	1010 hPa	Test Voltage :	DC 5V from adapter AC 120V/60Hz
Test Mode :	Mode 5	Polarization :	Vertical

Frequency (MHz)	Meter Reading (dBµV)	Factor (dB)	Emission Level (dBµV/m)	Limits (dBµV/m)	Margin (dB)	Detector Type
104.5361	15.97	10.91	26.88	43.5	-16.62	QP
125.0066	24	11.9	35.9	43.5	-7.6	QP
181.92	20.54	9.55	30.09	43.5	-13.41	QP
250.301	19.42	13.09	32.51	46	-13.49	QP
501.1788	15.31	19.43	34.74	46	-11.26	QP
640.6109	15.28	21.76	37.04	46	-8.96	QP

Remark:  
 Factor = Antenna Factor + Cable Loss – Pre-amplifier.

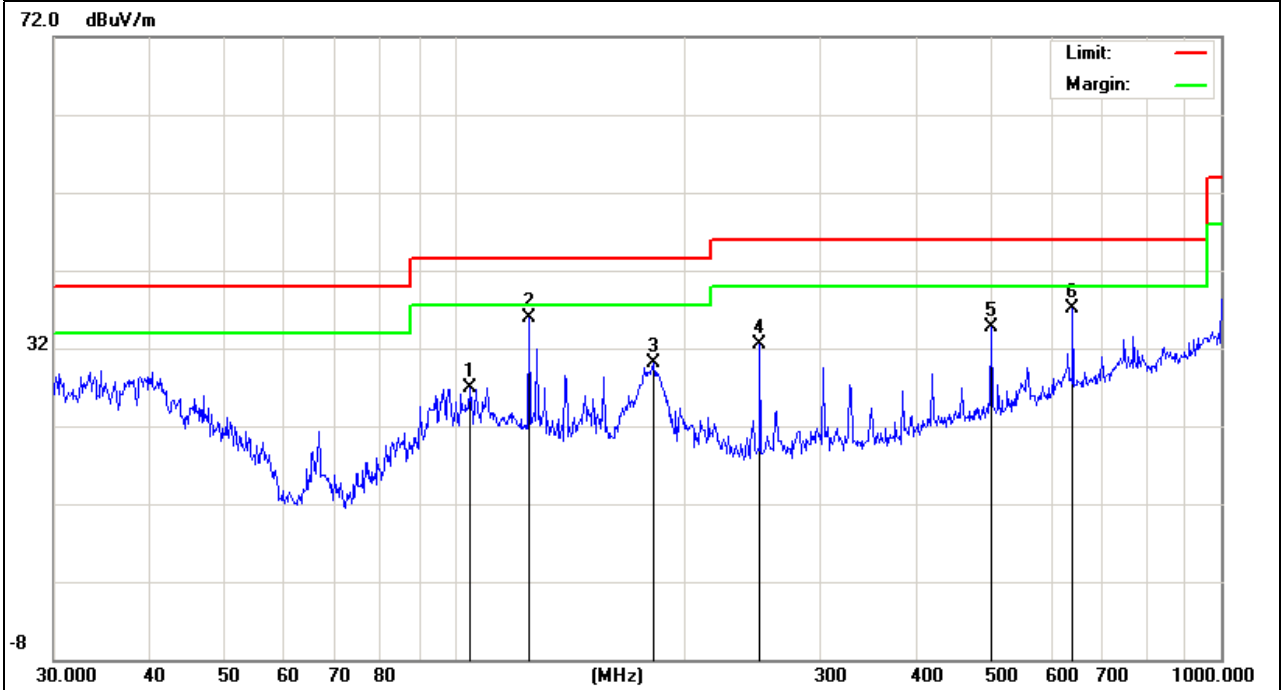



### 3.2.8 TEST RESULTS (ABOVE 1000 MHZ)

EUT :	TV BOX	Model Name :	Smartbox
Temperature :	20 °C	Relative Humidity :	48%
Pressure :	1010 hPa	Test Voltage :	DC 5V from adapter AC 120V/60Hz
Test Mode :	CH1 (802.11b Mode)	Polarization :	Horizontal

Frequency (MHz)	Meter Reading (dBµV)	Factor (dB)	Emission Level (dBµV/m)	Limits (dBµV/m)	Margin (dB)	Detector Type
4824.348	52.11	10.44	62.55	74	-11.45	peak
4824.348	33.18	10.44	43.62	54	-10.38	AVG
7236.473	44.35	12.39	56.74	74	-17.26	peak
7236.473	29	12.39	41.39	54	-12.61	AVG

Remark:  
Factor = Antenna Factor + Cable Loss – Pre-amplifier.

EUT :	TV BOX	Model Name :	Smartbox
Temperature :	20 °C	Relative Humidity :	48%
Pressure :	1010 hPa	Test Voltage :	DC 5V from adapter AC 120V/60Hz
Test Mode :	CH1 (802.11b Mode)	Polarization :	Vertical

Frequency (MHz)	Meter Reading (dBµV)	Factor (dB)	Emission Level (dBµV/m)	Limits (dBµV/m)	Margin (dB)	Detector Type
4874.247	51.17	10.4	61.57	74	-12.43	peak
4874.247	31.98	10.4	42.38	54	-11.62	AVG
7311.231	41.61	12.75	54.36	74	-19.64	peak
7311.231	27.66	12.75	40.41	54	-13.59	AVG

Remark:  
Factor = Antenna Factor + Cable Loss – Pre-amplifier.

EUT :	TV BOX	Model Name :	Smartbox
Temperature :	20 °C	Relative Humidity :	48%
Pressure :	1010 hPa	Test Voltage :	DC 5V from adapter AC 120V/60Hz
Test Mode :	CH6 (802.11b Mode)	Polarization :	Horizontal

Frequency (MHz)	Meter Reading (dBµV)	Factor (dB)	Emission Level (dBµV/m)	Limits (dBµV/m)	Margin (dB)	Detector Type
4874.234	49.82	10.4	60.22	74	-13.78	peak
4874.234	32.76	10.4	43.16	54	-10.84	AVG
7311.748	42.62	12.75	55.37	74	-18.63	peak
7311.748	29.68	12.75	42.43	54	-11.57	AVG

Remark:  
Factor = Antenna Factor + Cable Loss – Pre-amplifier.

EUT :	TV BOX	Model Name :	Smartbox
Temperature :	20 °C	Relative Humidity :	48%
Pressure :	1010 hPa	Test Voltage :	DC 5V from adapter AC 120V/60Hz
Test Mode :	CH6 (802.11b Mode)	Polarization :	Vertical

Frequency (MHz)	Meter Reading (dBµV)	Factor (dB)	Emission Level (dBµV/m)	Limits (dBµV/m)	Margin (dB)	Detector Type
4924.341	52.96	10.39	63.35	74	-10.65	peak
4934.341	32.05	10.44	42.49	54	-11.51	AVG
7386.208	42.55	12.68	55.23	74	-18.77	peak
7386.208	28.99	12.68	41.67	54	-12.33	AVG

Remark:  
Factor = Antenna Factor + Cable Loss – Pre-amplifier.

EUT :	TV BOX	Model Name :	Smartbox
Temperature :	20 °C	Relative Humidity :	48%
Pressure :	1010 hPa	Test Voltage :	DC 5V from adapter AC 120V/60Hz
Test Mode :	CH11 (802.11b Mode)	Polarization :	Horizontal

Frequency (MHz)	Meter Reading (dBµV)	Factor (dB)	Emission Level (dBµV/m)	Limits (dBµV/m)	Margin (dB)	Detector Type
4924.155	51.46	10.39	61.85	74	-12.15	peak
4924.155	33.27	10.39	43.66	54	-10.34	AVG
7386.242	42.89	12.68	55.57	74	-18.43	peak
7386.242	28.61	12.68	41.29	54	-12.71	AVG

Remark:  
Factor = Antenna Factor + Cable Loss – Pre-amplifier.

EUT :	TV BOX	Model Name :	Smartbox
Temperature :	20 °C	Relative Humidity :	48%
Pressure :	1010 hPa	Test Voltage :	DC 5V from adapter AC 120V/60Hz
Test Mode :	CH11 (802.11b Mode)	Polarization :	Vertical

Frequency (MHz)	Meter Reading (dBµV)	Factor (dB)	Emission Level (dBµV/m)	Limits (dBµV/m)	Margin (dB)	Detector Type
4924.238	51.84	10.39	62.23	74	-11.77	peak
4924.238	32.09	10.39	42.48	54	-11.52	AVG
7386.346	42.94	12.68	55.62	74	-18.38	peak
7386.346	27.91	12.68	40.59	54	-13.41	AVG

Remark:  
Factor = Antenna Factor + Cable Loss – Pre-amplifier.

EUT :	TV BOX	Model Name :	Smartbox
Temperature :	20 °C	Relative Humidity :	48%
Pressure :	1010 hPa	Test Voltage :	DC 5V from adapter AC 120V/60Hz
Test Mode :	CH1 (802.11g Mode)	Polarization :	Horizontal

Frequency (MHz)	Meter Reading (dBµV)	Factor (dB)	Emission Level (dBµV/m)	Limits (dBµV/m)	Margin (dB)	Detector Type
4824.374	47.03	10.44	57.47	74	-16.53	peak
4824.374	30.88	10.44	41.32	54	-12.68	AVG
7236.522	40.99	12.39	53.38	74	-20.62	peak
7236.522	26.07	12.39	38.46	54	-15.54	AVG

Remark:  
Factor = Antenna Factor + Cable Loss – Pre-amplifier.

EUT :	TV BOX	Model Name :	Smartbox
Temperature :	20 °C	Relative Humidity :	48%
Pressure :	1010 hPa	Test Voltage :	DC 5V from adapter AC 120V/60Hz
Test Mode :	CH1 (802.11g Mode)	Polarization :	Vertical

Frequency (MHz)	Meter Reading (dBµV)	Factor (dB)	Emission Level (dBµV/m)	Limits (dBµV/m)	Margin (dB)	Detector Type
4824.168	48.08	10.44	58.52	74	-15.48	peak
4824.168	32.04	10.44	42.48	54	-11.52	AVG
7236.342	41.99	12.39	54.38	74	-19.62	peak
7236.342	28.27	12.39	40.66	54	-13.34	AVG

Remark:  
Factor = Antenna Factor + Cable Loss – Pre-amplifier.

EUT :	TV BOX	Model Name :	Smartbox
Temperature :	20 °C	Relative Humidity :	48%
Pressure :	1010 hPa	Test Voltage :	DC 5V from adapter AC 120V/60Hz
Test Mode :	CH6 (802.11g Mode)	Polarization :	Horizontal

Frequency (MHz)	Meter Reading (dBµV)	Factor (dB)	Emission Level (dBµV/m)	Limits (dBµV/m)	Margin (dB)	Detector Type
4874.145	48.02	10.4	58.42	74	-15.58	peak
4874.145	31.42	10.4	41.82	54	-12.18	AVG
7311.269	41.68	12.75	54.43	74	-19.57	peak
7311.269	26.97	12.75	39.72	54	-14.28	AVG

Remark:  
Factor = Antenna Factor + Cable Loss – Pre-amplifier.

EUT :	TV BOX	Model Name :	Smartbox
Temperature :	20 °C	Relative Humidity :	48%
Pressure :	1010 hPa	Test Voltage :	DC 5V from adapter AC 120V/60Hz
Test Mode :	CH6 (802.11g Mode)	Polarization :	Vertical

Frequency (MHz)	Meter Reading (dBµV)	Factor (dB)	Emission Level (dBµV/m)	Limits (dBµV/m)	Margin (dB)	Detector Type
4874.177	48.07	10.4	58.47	74	-15.53	peak
4874.177	31.89	10.4	42.29	54	-11.71	AVG
7311.224	42.78	12.75	55.53	74	-18.47	peak
7311.224	27.99	12.75	40.74	54	-13.26	AVG

Remark:  
Factor = Antenna Factor + Cable Loss – Pre-amplifier.

EUT :	TV BOX	Model Name :	Smartbox
Temperature :	20 °C	Relative Humidity :	48%
Pressure :	1010 hPa	Test Voltage :	DC 5V from adapter AC 120V/60Hz
Test Mode :	CH11 (802.11g Mode)	Polarization :	Horizontal

Frequency (MHz)	Meter Reading (dBµV)	Factor (dB)	Emission Level (dBµV/m)	Limits (dBµV/m)	Margin (dB)	Detector Type
4924.235	48.12	10.39	58.51	74	-15.49	peak
4924.235	33.07	10.39	43.46	54	-10.54	AVG
7386.316	42.81	12.68	55.49	74	-18.51	peak
7386.316	27.89	12.68	40.57	54	-13.43	AVG

Remark:  
Factor = Antenna Factor + Cable Loss – Pre-amplifier.

EUT :	TV BOX	Model Name :	Smartbox
Temperature :	20 °C	Relative Humidity :	48%
Pressure :	1010 hPa	Test Voltage :	DC 5V from adapter AC 120V/60Hz
Test Mode :	CH11(802.11g Mode)	Polarization :	Vertical

Frequency (MHz)	Meter Reading (dBµV)	Factor (dB)	Emission Level (dBµV/m)	Limits (dBµV/m)	Margin (dB)	Detector Type
4924.146	47.43	10.39	57.82	74	-16.18	peak
4924.146	32.54	10.39	42.93	54	-11.07	AVG
7386.225	42.19	12.68	54.87	74	-19.13	peak
7386.225	28.75	12.68	41.43	54	-12.57	AVG

Remark:  
Factor = Antenna Factor + Cable Loss – Pre-amplifier.

EUT :	TV BOX	Model Name :	Smartbox
Temperature :	20 °C	Relative Humidity :	48%
Pressure :	1010 hPa	Test Voltage :	DC 5V from adapter AC 120V/60Hz
Test Mode :	CH1 (802.11n/20M Mode)	Polarization :	Horizontal

Frequency (MHz)	Meter Reading (dBµV)	Factor (dB)	Emission Level (dBµV/m)	Limits (dBµV/m)	Margin (dB)	Detector Type
4824.062	49.08	10.44	59.52	74	-14.48	peak
4824.062	33.04	10.44	43.48	54	-10.52	AVG
7236.351	41.47	12.39	53.86	74	-20.14	peak
7236.351	29.4	12.39	41.79	54	-12.21	AVG

Remark:  
Factor = Antenna Factor + Cable Loss – Pre-amplifier.

EUT :	TV BOX	Model Name :	Smartbox
Temperature :	20 °C	Relative Humidity :	48%
Pressure :	1010 hPa	Test Voltage :	DC 5V from adapter AC 120V/60Hz
Test Mode :	CH1 (802.11n/20M Mode)	Polarization :	Vertical

Frequency (MHz)	Meter Reading (dBµV)	Factor (dB)	Emission Level (dBµV/m)	Limits (dBµV/m)	Margin (dB)	Detector Type
4824.247	48.15	10.44	58.59	74	-15.41	peak
4824.247	32.3	10.44	42.74	54	-11.26	AVG
7236.336	41.87	12.39	54.26	74	-19.74	peak
7236.336	28.23	12.39	40.62	54	-13.38	AVG

Remark:  
Factor = Antenna Factor + Cable Loss – Pre-amplifier.

EUT :	TV BOX	Model Name :	Smartbox
Temperature :	20 °C	Relative Humidity :	48%
Pressure :	1010 hPa	Test Voltage :	DC 5V from adapter AC 120V/60Hz
Test Mode :	CH6 (802.11n/20M Mode)	Polarization :	Horizontal

Frequency (MHz)	Meter Reading (dBμV)	Factor (dB)	Emission Level (dBμV/m)	Limits (dBμV/m)	Margin (dB)	Detector Type
4874.437	48.41	10.4	58.81	74	-15.19	peak
4874.437	31.04	10.4	41.44	54	-12.56	AVG
7311.265	41.6	12.75	54.35	74	-19.65	peak
7311.265	26.84	12.75	39.59	54	-14.41	AVG

Remark:  
Factor = Antenna Factor + Cable Loss – Pre-amplifier.



EUT :	TV BOX	Model Name :	Smartbox
Temperature :	20 °C	Relative Humidity :	48%
Pressure :	1010 hPa	Test Voltage :	DC 5V from adapter AC 120V/60Hz
Test Mode :	CH6 (802.11n/20M Mode)	Polarization :	Vertical

Frequency (MHz)	Meter Reading (dBµV)	Factor (dB)	Emission Level (dBµV/m)	Limits (dBµV/m)	Margin (dB)	Detector Type
4874.428	47.85	10.4	58.25	74	-15.75	peak
4874.428	31.23	10.4	41.63	54	-12.37	AVG
7311.374	41.73	12.75	54.48	74	-19.52	peak
7311.374	27.54	12.75	40.29	54	-13.71	AVG

Remark:  
Factor = Antenna Factor + Cable Loss – Pre-amplifier.

EUT :	TV BOX	Model Name :	Smartbox
Temperature :	20 °C	Relative Humidity :	48%
Pressure :	1010 hPa	Test Voltage :	DC 5V from adapter AC 120V/60Hz
Test Mode :	CH11 (802.11n/20M Mode)	Polarization :	Horizontal

Frequency (MHz)	Meter Reading (dBµV)	Factor (dB)	Emission Level (dBµV/m)	Limits (dBµV/m)	Margin (dB)	Detector Type
4924.248	48.96	10.39	59.35	74	-14.65	peak
4924.248	31.08	10.39	41.47	54	-12.53	AVG
7386.386	41.97	12.69	54.66	74	-19.34	peak
7386.386	26.99	12.69	39.68	54	-14.32	AVG

Remark:  
Factor = Antenna Factor + Cable Loss – Pre-amplifier.

EUT :	TV BOX	Model Name :	Smartbox
Temperature :	20 °C	Relative Humidity :	48%
Pressure :	1010 hPa	Test Voltage :	DC 5V from adapter AC 120V/60Hz
Test Mode :	CH11 (802.11n/20M Mode)	Polarization :	Vertical

Frequency (MHz)	Meter Reading (dBµV)	Factor (dB)	Emission Level (dBµV/m)	Limits (dBµV/m)	Margin (dB)	Detector Type
4924.319	49.03	10.39	59.42	74	-14.58	peak
4924.319	31.99	10.39	42.38	54	-11.62	AVG
7386.157	43.88	12.68	56.56	74	-17.44	peak
7386.157	28.05	12.68	40.73	54	-13.27	AVG

Remark:  
Factor = Antenna Factor + Cable Loss – Pre-amplifier.

EUT :	TV BOX	Model Name :	Smartbox
Temperature :	20 °C	Relative Humidity :	48%
Pressure :	1010 hPa	Test Voltage :	DC 5V from adapter AC 120V/60Hz
Test Mode :	CH3 (802.11n/40M Mode)	Polarization :	Horizontal

Frequency (MHz)	Meter Reading (dBµV)	Factor (dB)	Emission Level (dBµV/m)	Limits (dBµV/m)	Margin (dB)	Detector Type
4844.164	46.81	10.5	57.31	74	-16.69	peak
4844.164	31.93	10.5	42.43	54	-11.57	AVG
7266.342	41.4	12.5	53.9	74	-20.1	peak
7266.342	28.03	12.5	40.53	54	-13.47	AVG

Remark:  
Factor = Antenna Factor + Cable Loss – Pre-amplifier.

EUT :	TV BOX	Model Name :	Smartbox
Temperature :	20 °C	Relative Humidity :	48%
Pressure :	1010 hPa	Test Voltage :	DC 5V from adapter AC 120V/60Hz
Test Mode :	CH3 (802.11n/40M Mode)	Polarization :	Vertical

Frequency (MHz)	Meter Reading (dBµV)	Factor (dB)	Emission Level (dBµV/m)	Limits (dBµV/m)	Margin (dB)	Detector Type
4844.365	45.8	10.5	56.3	74	-17.7	peak
4844.365	31.97	10.5	42.47	54	-11.53	AVG
7266.221	41.06	12.5	53.56	74	-20.44	peak
7266.221	27.93	12.5	40.43	54	-13.57	AVG

Remark:  
Factor = Antenna Factor + Cable Loss – Pre-amplifier.

EUT :	TV BOX	Model Name :	Smartbox
Temperature :	20 °C	Relative Humidity :	48%
Pressure :	1010 hPa	Test Voltage :	DC 5V from adapter AC 120V/60Hz
Test Mode :	CH6 (802.11n/40M Mode)	Polarization :	Horizontal

Frequency (MHz)	Meter Reading (dBµV)	Factor (dB)	Emission Level (dBµV/m)	Limits (dBµV/m)	Margin (dB)	Detector Type
4874.233	47.06	10.4	57.46	74	-16.54	peak
4874.233	32.25	10.4	42.65	54	-11.35	AVG
7311.152	40.98	12.75	53.73	74	-20.27	peak
7311.152	28.92	12.75	41.67	54	-12.33	AVG

Remark:  
Factor = Antenna Factor + Cable Loss – Pre-amplifier.

EUT :	TV BOX	Model Name :	Smartbox
Temperature :	20 °C	Relative Humidity :	48%
Pressure :	1010 hPa	Test Voltage :	DC 5V from adapter AC 120V/60Hz
Test Mode :	CH6 (802.11n/40M Mode)	Polarization :	Vertical

Frequency (MHz)	Meter Reading (dBμV)	Factor (dB)	Emission Level (dBμV/m)	Limits (dBμV/m)	Margin (dB)	Detector Type
4874.542	46.84	10.4	57.24	74	-16.76	peak
4874.542	32.88	10.4	43.28	54	-10.72	AVG
7311.639	40.88	12.75	53.63	74	-20.37	peak
7311.639	28.88	12.75	41.63	54	-12.37	AVG

Remark:  
 Factor = Antenna Factor + Cable Loss – Pre-amplifier.

EUT :	TV BOX	Model Name :	Smartbox
Temperature :	20 °C	Relative Humidity :	48%
Pressure :	1010 hPa	Test Voltage :	DC 5V from adapter AC 120V/60Hz
Test Mode :	CH9 (802.11n/40M Mode)	Polarization :	Horizontal

Frequency (MHz)	Meter Reading (dBµV)	Factor (dB)	Emission Level (dBµV/m)	Limits (dBµV/m)	Margin (dB)	Detector Type
4904.348	47.25	10.29	57.54	74	-16.46	peak
4904.348	32.25	10.29	42.54	54	-11.46	AVG
7356.246	40.89	12.79	53.68	74	-20.32	peak
7356.246	27.9	12.79	40.69	54	-13.31	AVG

Remark:  
 Factor = Antenna Factor + Cable Loss – Pre-amplifier.

EUT :	TV BOX	Model Name :	Smartbox
Temperature :	20 °C	Relative Humidity :	48%
Pressure :	1010 hPa	Test Voltage :	DC 5V from adapter AC 120V/60Hz
Test Mode :	CH9 (802.11n/40M Mode)	Polarization :	Vertical

Frequency (MHz)	Meter Reading (dBµV)	Factor (dB)	Emission Level (dBµV/m)	Limits (dBµV/m)	Margin (dB)	Detector Type
4904.138	47.28	10.29	57.57	74	-16.43	peak
4904.138	32.05	10.29	42.34	54	-11.66	AVG
7356.423	40.9	12.79	53.69	74	-20.31	peak
7356.423	28.93	12.79	41.72	54	-12.28	AVG

Remark:  
Factor = Antenna Factor + Cable Loss – Pre-amplifier.

**Band Edge Emission:**

EUT :	TV BOX	Model Name :	Smartbox
Temperature :	20 °C	Relative Humidity :	48%
Pressure :	1010 hPa	Test Voltage :	DC 5V from adapter AC 120V/60Hz
Test Mode :	CH1(802.11b Mode)	Polarization :	Horizontal

Frequency (MHz)	Meter Reading (dBµV)	Factor (dB)	Emission Level (dBµV/m)	Limits (dBµV/m)	Margin (dB)	Detector Type
2400	82.19	-12.99	69.2	74	-4.8	peak
2400	59.82	-12.99	46.83	54	-7.17	AVG

Remark:  
Factor = Antenna Factor + Cable Loss – Pre-amplifier.

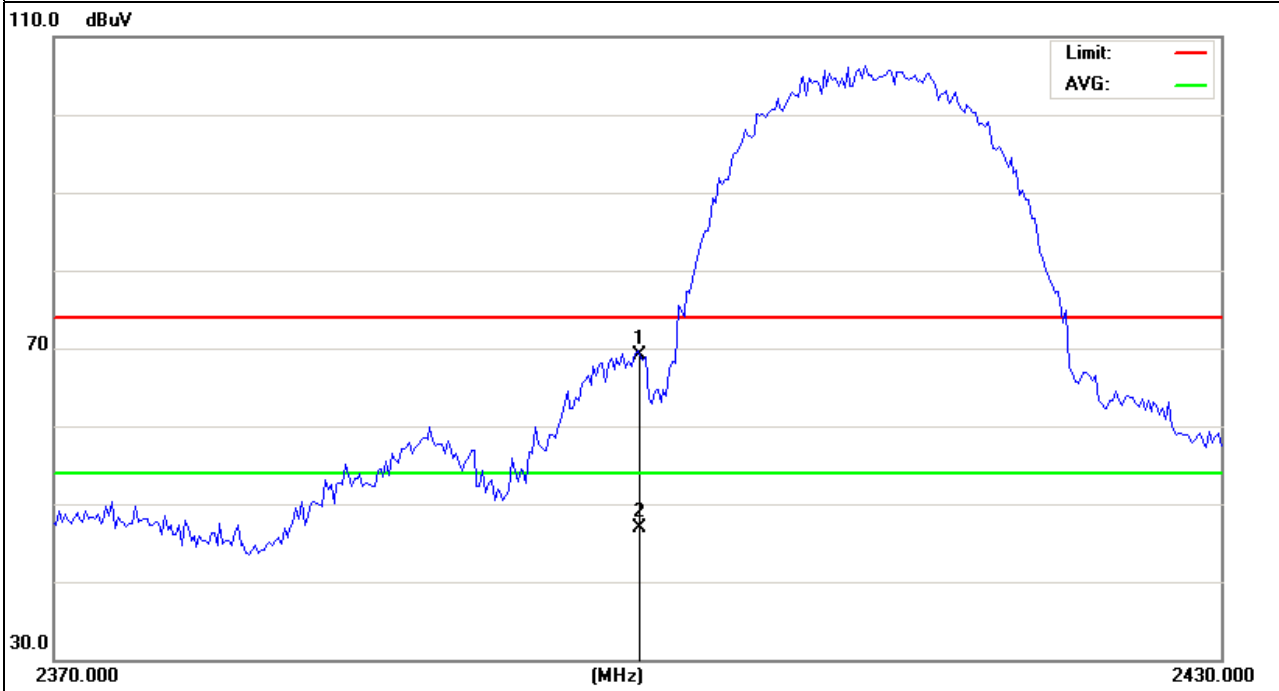

EUT :	TV BOX	Model Name :	Smartbox
Temperature :	20 °C	Relative Humidity :	48%
Pressure :	1010 hPa	Test Voltage :	DC 5V from adapter AC 120V/60Hz
Test Mode :	CH1(802.11b Mode)	Polarization :	Vertical

Frequency (MHz)	Meter Reading (dBµV)	Factor (dB)	Emission Level (dBµV/m)	Limits (dBµV/m)	Margin (dB)	Detector Type
2400	84.39	-12.99	71.4	74	-2.6	peak
2400	59.62	-12.99	46.63	54	-7.37	AVG

Remark:  
Factor = Antenna Factor + Cable Loss – Pre-amplifier.

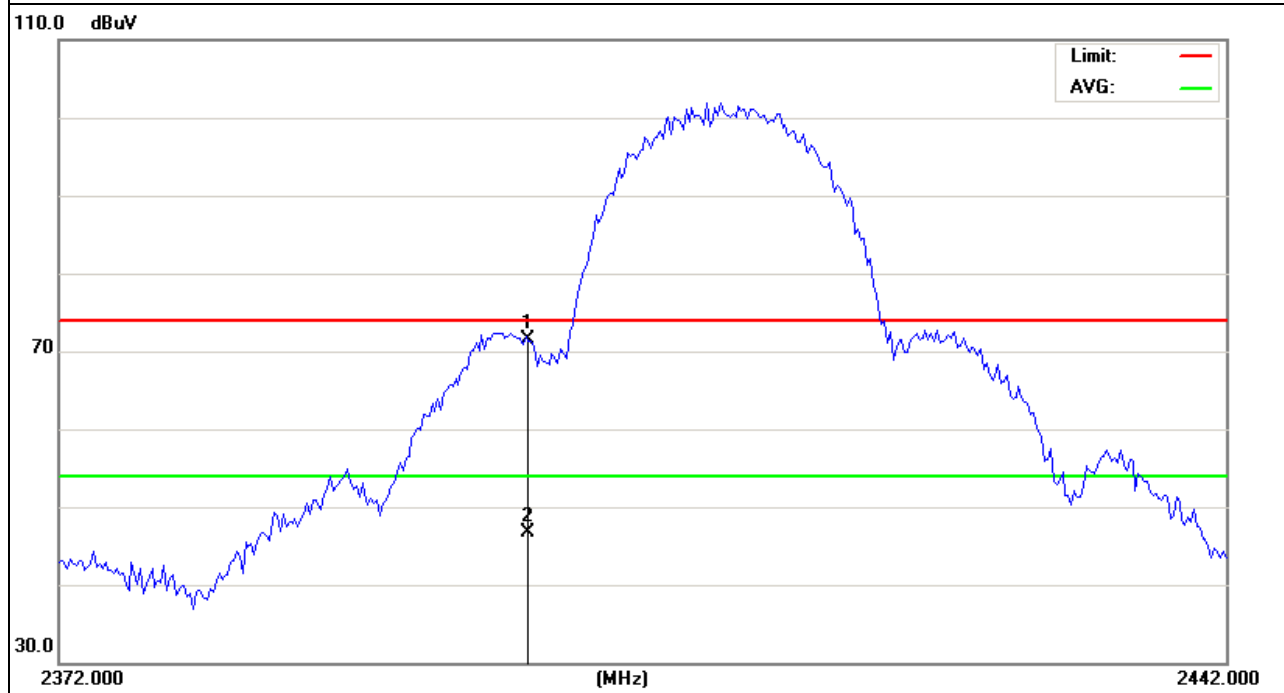



EUT :	TV BOX	Model Name :	Smartbox
Temperature :	20 °C	Relative Humidity :	48%
Pressure :	1010 hPa	Test Voltage :	DC 5V from adapter AC 120V/60Hz
Test Mode :	CH11(802.11b Mode)	Polarization :	Horizontal

Frequency (MHz)	Meter Reading (dBµV)	Factor (dB)	Emission Level (dBµV/m)	Limits (dBµV/m)	Margin (dB)	Detector Type
2483.5	61.68	-12.78	48.9	74	-25.1	peak

Remark:  
Factor = Antenna Factor + Cable Loss – Pre-amplifier.

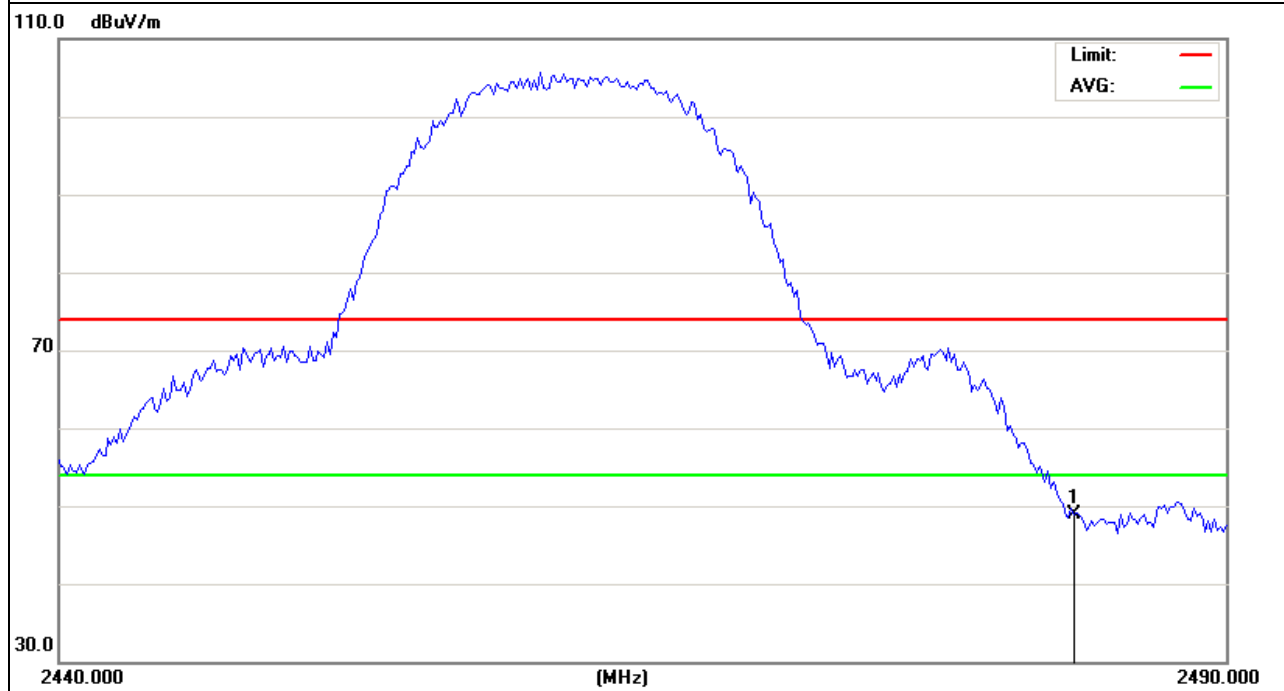

EUT :	TV BOX	Model Name :	Smartbox
Temperature :	20 °C	Relative Humidity :	48%
Pressure :	1010 hPa	Test Voltage :	DC 5V from adapter AC 120V/60Hz
Test Mode :	CH11(802.11b Mode)	Polarization :	Vertical

Frequency (MHz)	Meter Reading (dBµV)	Factor (dB)	Emission Level (dBµV/m)	Limits (dBµV/m)	Margin (dB)	Detector Type
2483.5	62.18	-12.78	49.4	74	-24.6	peak

Remark:  
Factor = Antenna Factor + Cable Loss – Pre-amplifier.

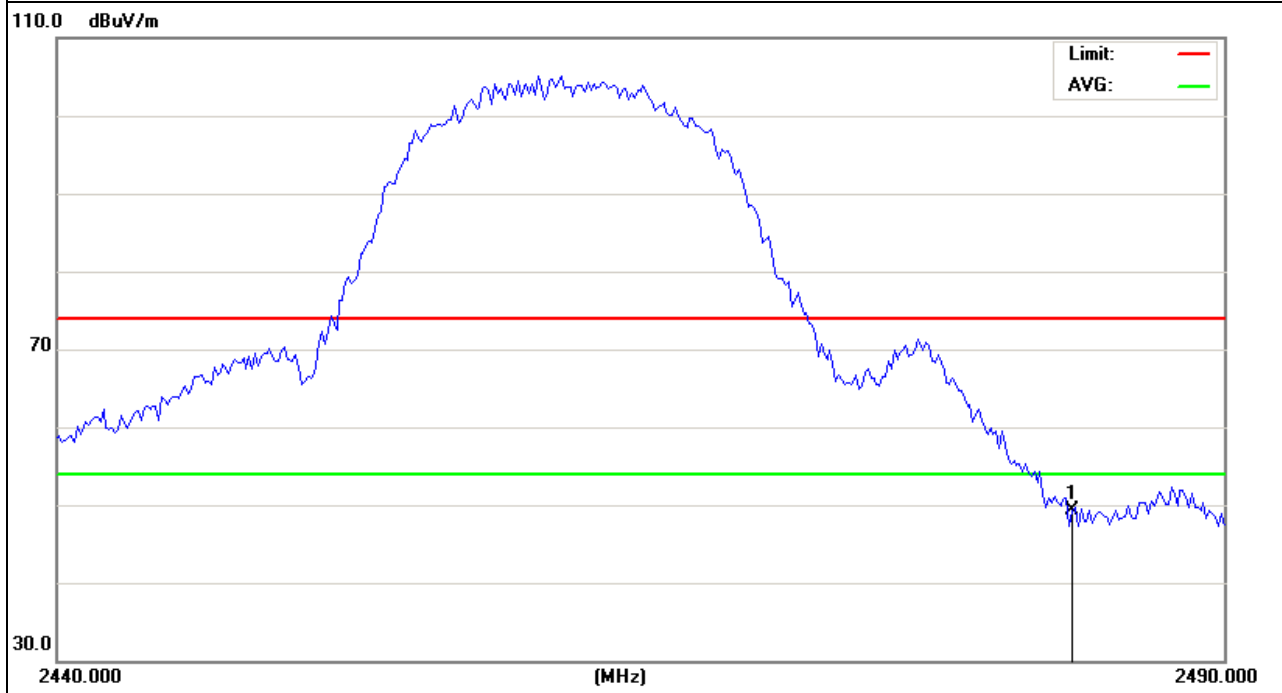

EUT :	TV BOX	Model Name :	Smartbox
Temperature :	20 °C	Relative Humidity :	48%
Pressure :	1010 hPa	Test Voltage :	DC 5V from adapter AC 120V/60Hz
Test Mode :	CH1(802.11g Mode)	Polarization :	Horizontal

Frequency (MHz)	Meter Reading (dBμV)	Factor (dB)	Emission Level (dBμV/m)	Limits (dBμV/m)	Margin (dB)	Detector Type
2400	79.32	-12.99	66.33	74	-7.67	peak
2400	57.27	-12.99	44.28	54	-9.72	AVG

Remark:  
Factor = Antenna Factor + Cable Loss – Pre-amplifier.

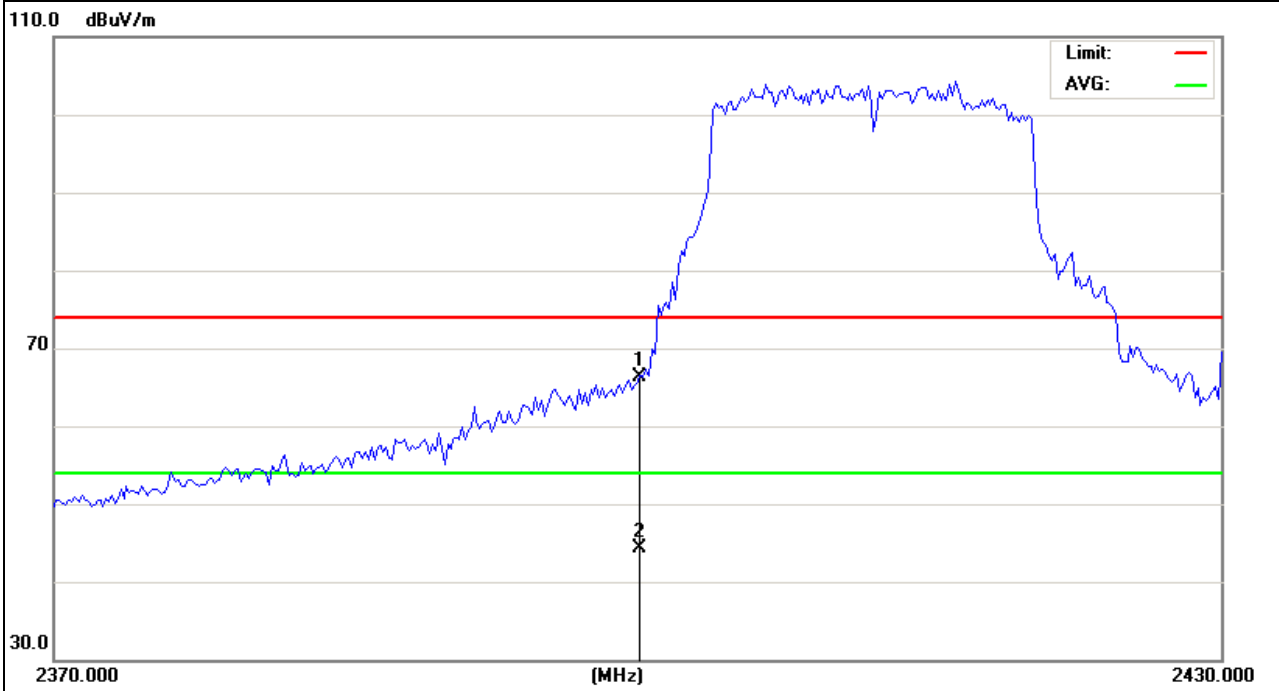

EUT :	TV BOX	Model Name :	Smartbox
Temperature :	20 °C	Relative Humidity :	48%
Pressure :	1010 hPa	Test Voltage :	DC 5V from adapter AC 120V/60Hz
Test Mode :	CH1(802.11gMode)	Polarization :	Vertical

Frequency (MHz)	Meter Reading (dBµV)	Factor (dB)	Emission Level (dBµV/m)	Limits (dBµV/m)	Margin (dB)	Detector Type
2400	83.59	-12.99	70.6	74	-3.4	peak
2400	60.37	-12.99	47.38	54	-6.62	AVG

Remark:  
Factor = Antenna Factor + Cable Loss – Pre-amplifier.

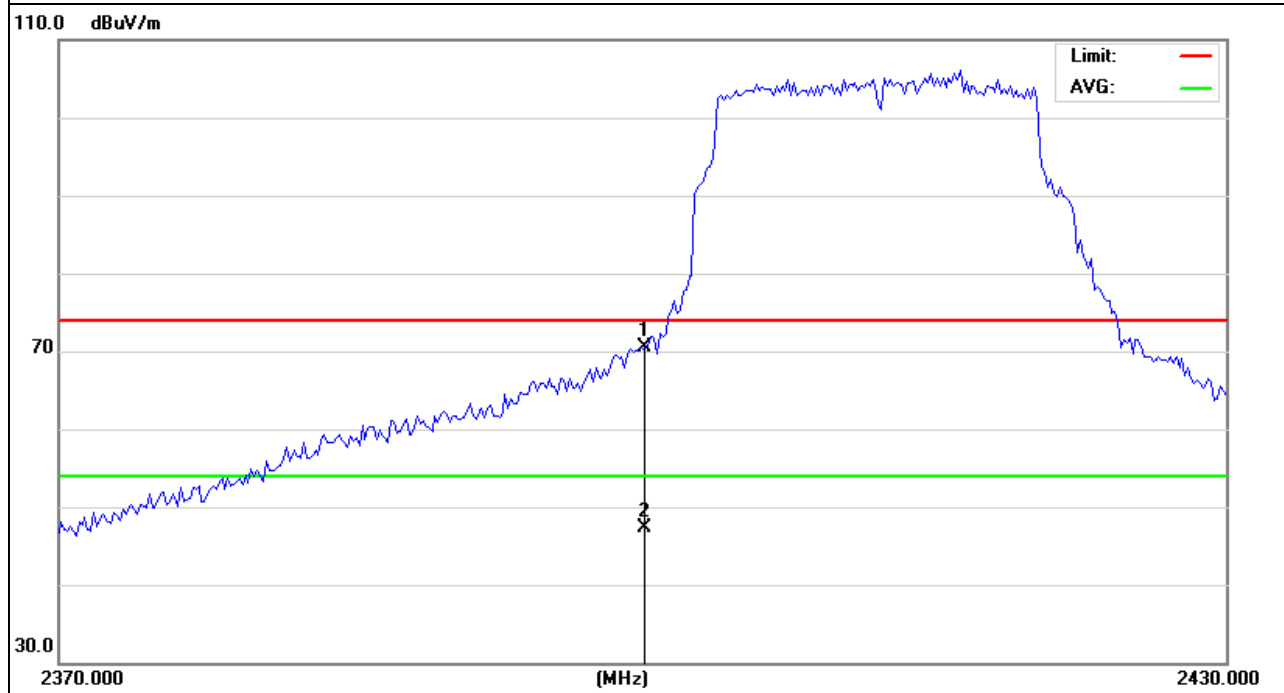

EUT :	TV BOX	Model Name :	Smartbox
Temperature :	20 °C	Relative Humidity :	48%
Pressure :	1010 hPa	Test Voltage :	DC 5V from adapter AC 120V/60Hz
Test Mode :	CH11(802.11g Mode)	Polarization :	Horizontal

Frequency (MHz)	Meter Reading (dBμV)	Factor (dB)	Emission Level (dBμV/m)	Limits (dBμV/m)	Margin (dB)	Detector Type
2483.5	64.68	-12.78	51.9	74	-22.1	peak

Remark:  
Factor = Antenna Factor + Cable Loss – Pre-amplifier.

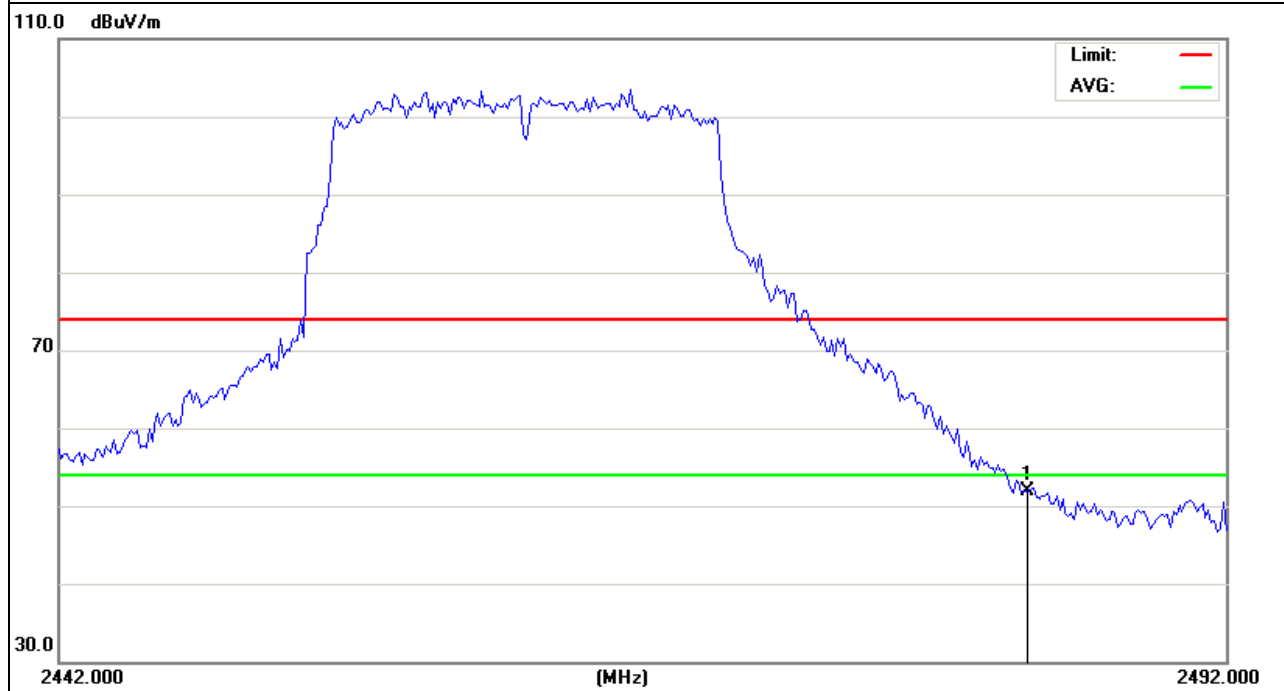

EUT :	TV BOX	Model Name :	Smartbox
Temperature :	20 °C	Relative Humidity :	48%
Pressure :	1010 hPa	Test Voltage :	DC 5V from adapter AC 120V/60Hz
Test Mode :	CH11(802.11g Mode)	Polarization :	Vertical

Frequency (MHz)	Meter Reading (dBµV)	Factor (dB)	Emission Level (dBµV/m)	Limits (dBµV/m)	Margin (dB)	Detector Type
2483.5	80.4	-12.78	67.62	74	-6.38	peak
2483.5	60.15	-12.78	47.37	54	-6.63	AVG

Remark:  
Factor = Antenna Factor + Cable Loss – Pre-amplifier.

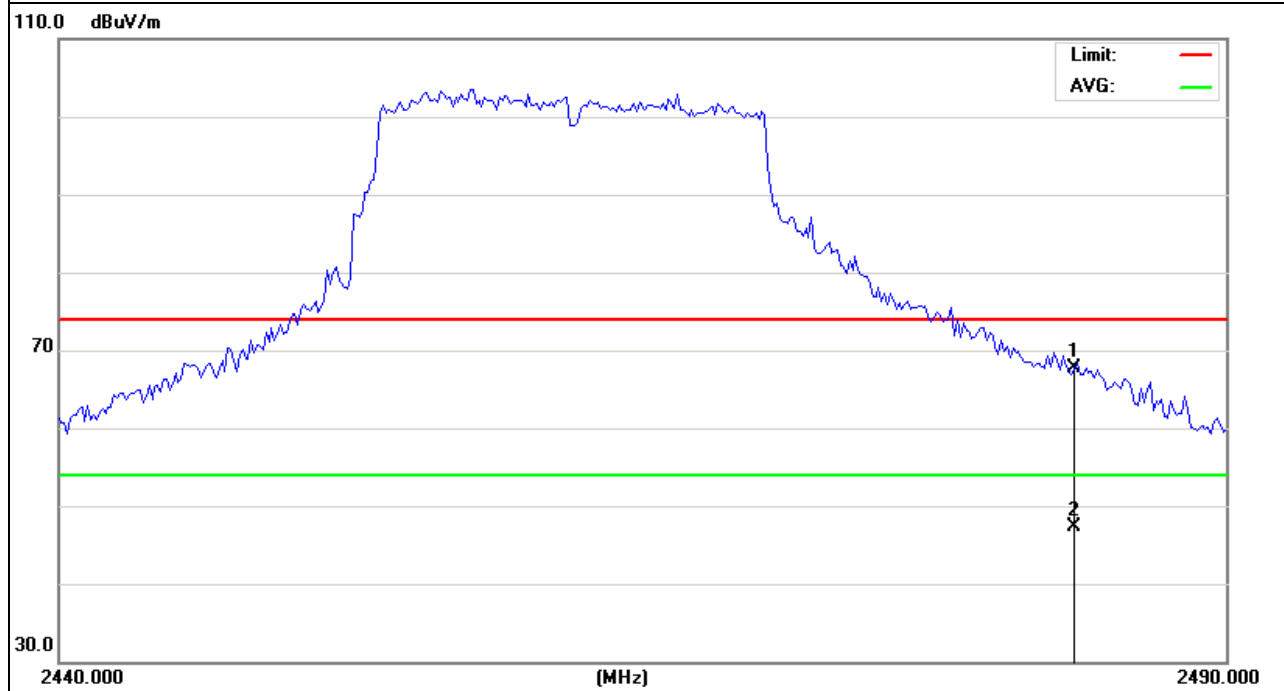

EUT :	TV BOX	Model Name :	Smartbox
Temperature :	20 °C	Relative Humidity :	48%
Pressure :	1010 hPa	Test Voltage :	DC 5V from adapter AC 120V/60Hz
Test Mode :	CH1(802.11n Mode/20MHz)	Polarization :	Horizontal

Frequency (MHz)	Meter Reading (dBµV)	Factor (dB)	Emission Level (dBµV/m)	Limits (dBµV/m)	Margin (dB)	Detector Type
2400	84.29	-12.99	71.3	74	-2.7	peak
2400	60.84	-12.99	47.85	54	-6.15	AVG

Remark:  
Factor = Antenna Factor + Cable Loss – Pre-amplifier.

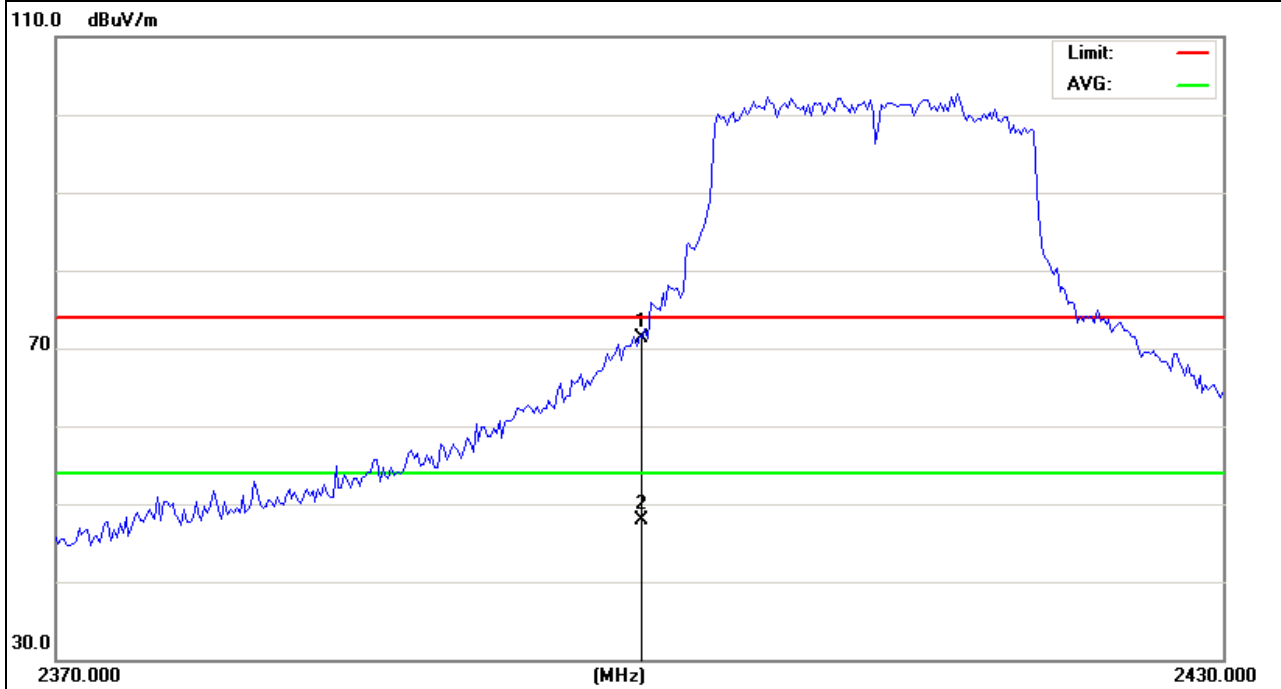

EUT :	TV BOX	Model Name :	Smartbox
Temperature :	20 °C	Relative Humidity :	48%
Pressure :	1010 hPa	Test Voltage :	DC 5V from adapter AC 120V/60Hz
Test Mode :	CH1(802.11n Mode/20MHz)	Polarization :	Vertical

Frequency (MHz)	Meter Reading (dBμV)	Factor (dB)	Emission Level (dBμV/m)	Limits (dBμV/m)	Margin (dB)	Detector Type
2400	83.79	-12.99	70.8	74	-3.2	peak
2400	60.33	-12.99	47.34	54	-6.66	AVG

Remark:  
Factor = Antenna Factor + Cable Loss – Pre-amplifier.

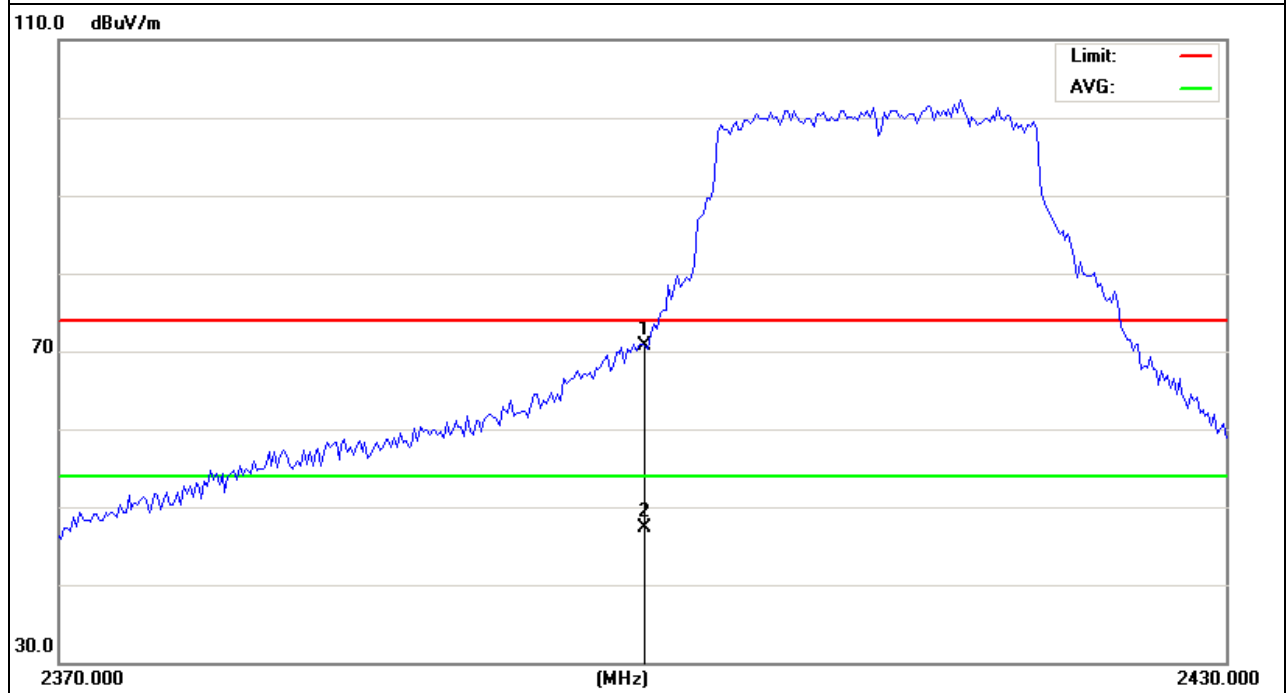



EUT :	TV BOX	Model Name :	Smartbox
Temperature :	20 °C	Relative Humidity :	48%
Pressure :	1010 hPa	Test Voltage :	DC 5V from adapter AC 120V/60Hz
Test Mode :	CH11(802.11n Mode/20MHz)	Polarization :	Horizontal

Frequency (MHz)	Meter Reading (dBµV)	Factor (dB)	Emission Level (dBµV/m)	Limits (dBµV/m)	Margin (dB)	Detector Type
2483.5	78.11	-12.78	65.33	74	-8.67	peak
2483.5	57.19	-12.78	44.41	54	-9.59	AVG

Remark:  
Factor = Antenna Factor + Cable Loss – Pre-amplifier.

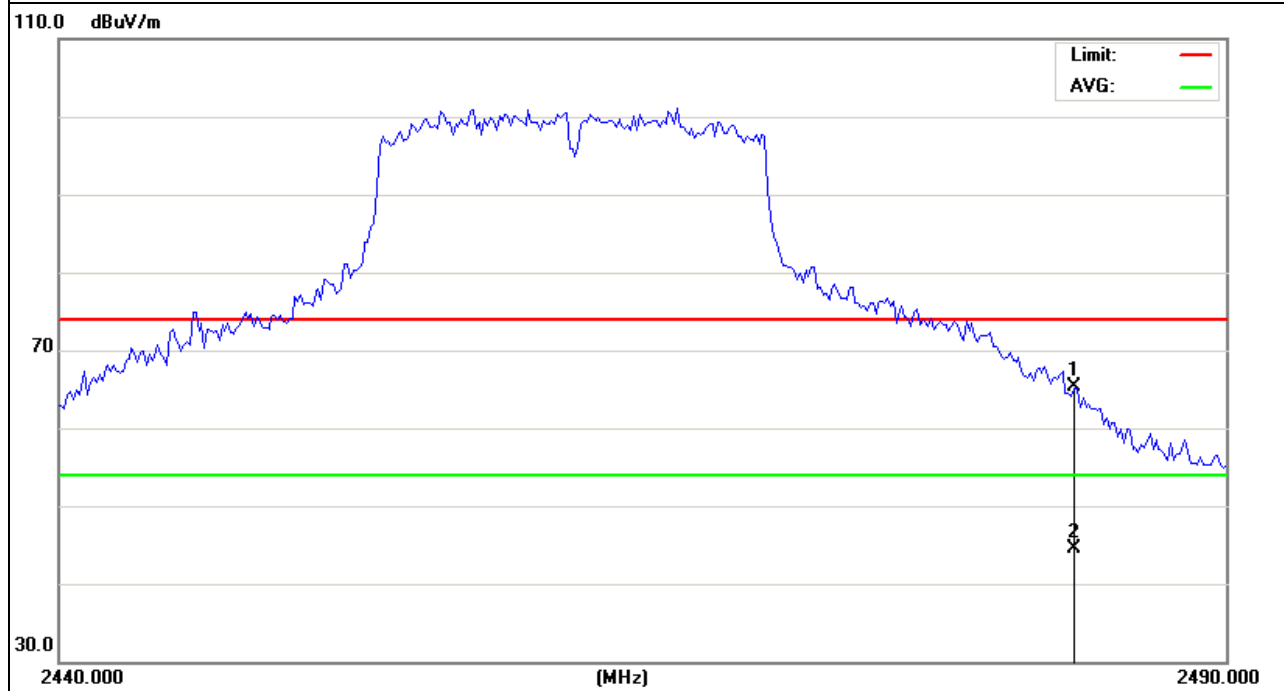

EUT :	TV BOX	Model Name :	Smartbox
Temperature :	20 °C	Relative Humidity :	48%
Pressure :	1010 hPa	Test Voltage :	DC 5V from adapter AC 120V/60Hz
Test Mode :	CH11(802.11n Mode/20MHz)	Polarization :	Vertical

Frequency (MHz)	Meter Reading (dBμV)	Factor (dB)	Emission Level (dBμV/m)	Limits (dBμV/m)	Margin (dB)	Detector Type
2483.5	77.54	-12.78	64.76	74	-9.24	peak
2483.5	57.46	-12.78	44.68	54	-9.32	AVG

Remark:  
Factor = Antenna Factor + Cable Loss – Pre-amplifier.

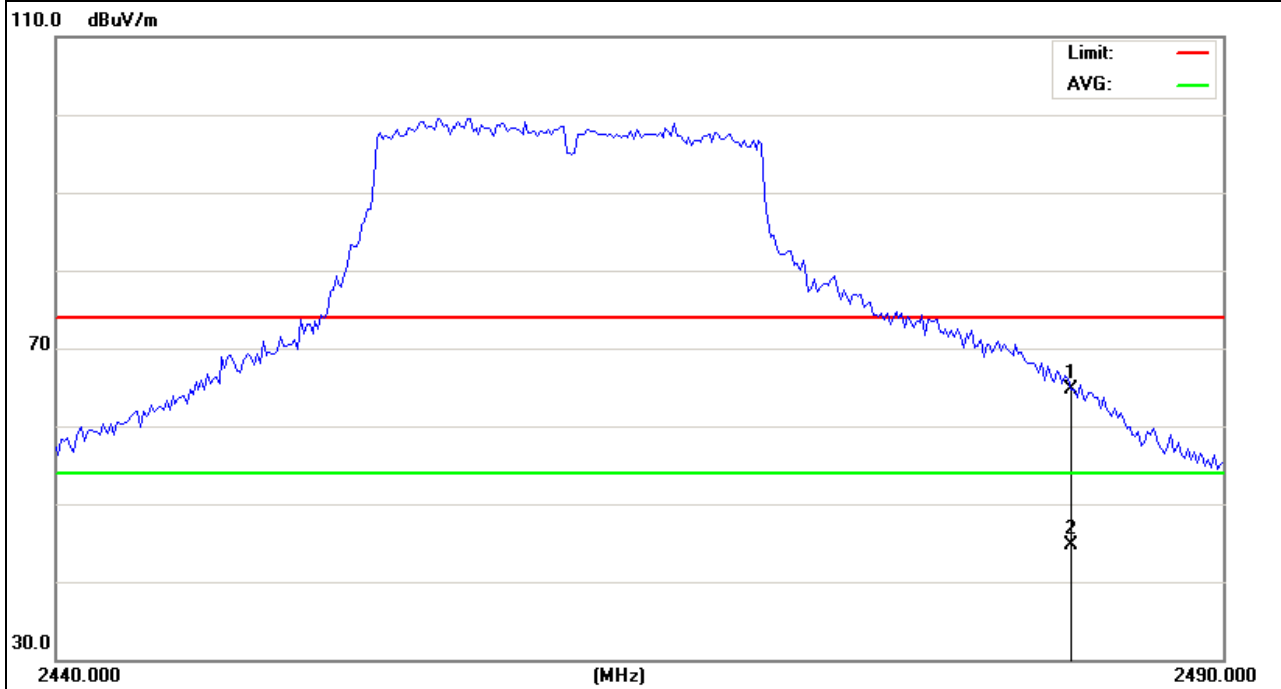

EUT :	TV BOX	Model Name :	Smartbox
Temperature :	20 °C	Relative Humidity :	48%
Pressure :	1010 hPa	Test Voltage :	DC 5V from adapter AC 120V/60Hz
Test Mode :	CH3(802.11n Mode/40MHz)	Polarization :	Horizontal

Frequency (MHz)	Meter Reading (dBµV)	Factor (dB)	Emission Level (dBµV/m)	Limits (dBµV/m)	Margin (dB)	Detector Type
2400	74.99	-12.99	62	74	-12	peak
2400	57.83	-12.99	44.84	54	-9.16	AVG

Remark:  
Factor = Antenna Factor + Cable Loss – Pre-amplifier.

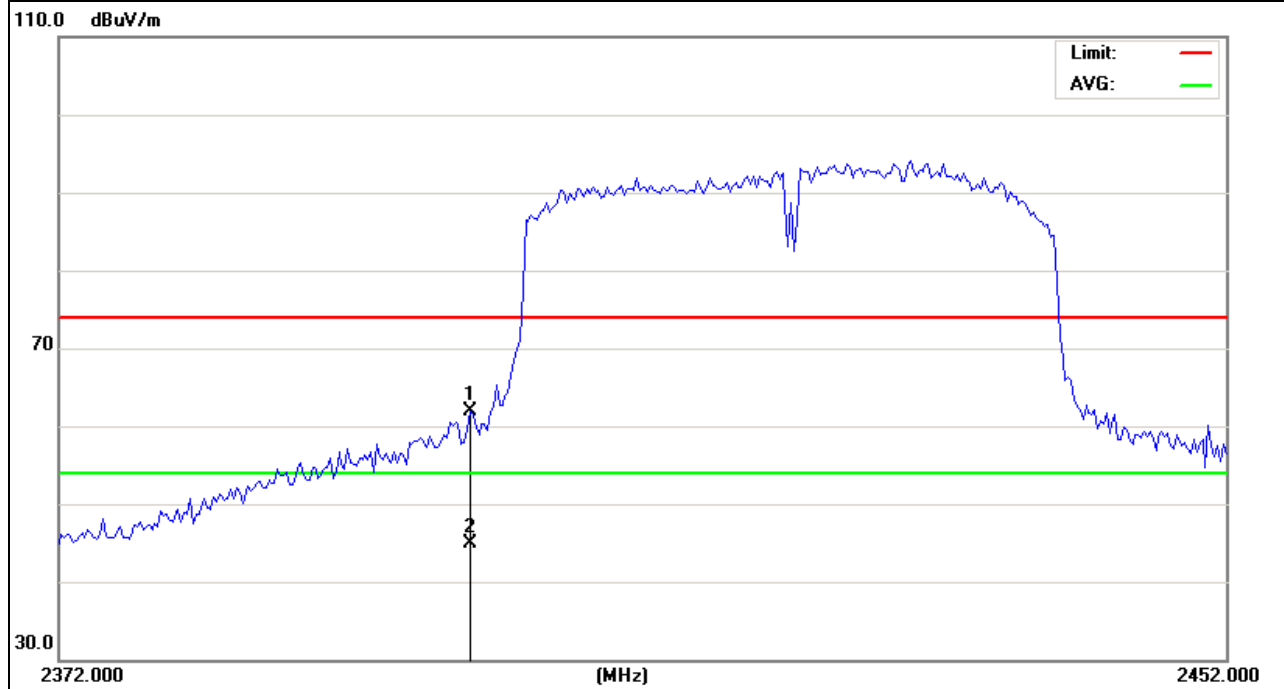

EUT :	TV BOX	Model Name :	Smartbox
Temperature :	20 °C	Relative Humidity :	48%
Pressure :	1010 hPa	Test Voltage :	DC 5V from adapter AC 120V/60Hz
Test Mode :	CH3(802.11n Mode/40MHz)	Polarization :	Vertical

Frequency (MHz)	Meter Reading (dBμV)	Factor (dB)	Emission Level (dBμV/m)	Limits (dBμV/m)	Margin (dB)	Detector Type
2400	80.11	-12.99	67.12	74	-6.88	peak
2400	58.62	-12.99	45.63	54	-8.37	AVG

Remark:  
Factor = Antenna Factor + Cable Loss – Pre-amplifier.

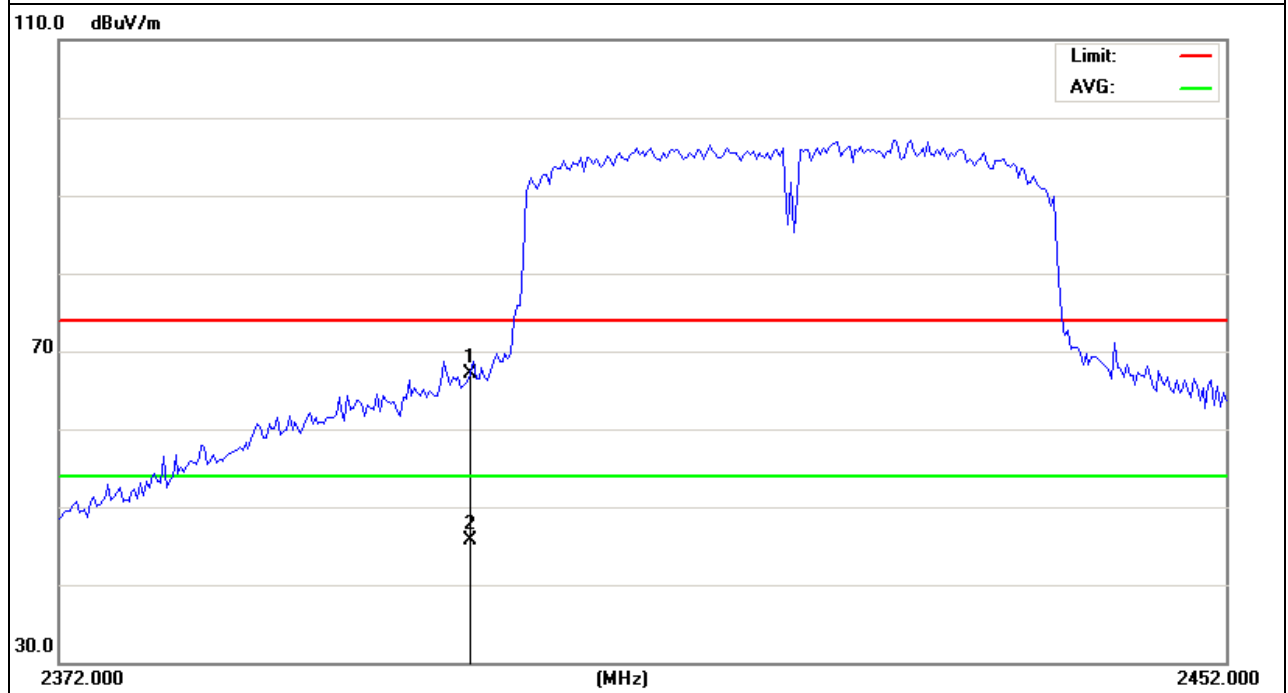

EUT :	TV BOX	Model Name :	Smartbox
Temperature :	20 °C	Relative Humidity :	48%
Pressure :	1010 hPa	Test Voltage :	DC 5V from adapter AC 120V/60Hz
Test Mode :	CH9(802.11n Mode/40MHz)	Polarization :	Horizontal

Frequency (MHz)	Meter Reading (dBμV)	Factor (dB)	Emission Level (dBμV/m)	Limits (dBμV/m)	Margin (dB)	Detector Type
2483.5	69.42	-12.78	56.64	74	-17.36	peak
2483.5	54.61	-12.78	41.83	54	-12.17	AVG

Remark:  
Factor = Antenna Factor + Cable Loss – Pre-amplifier.

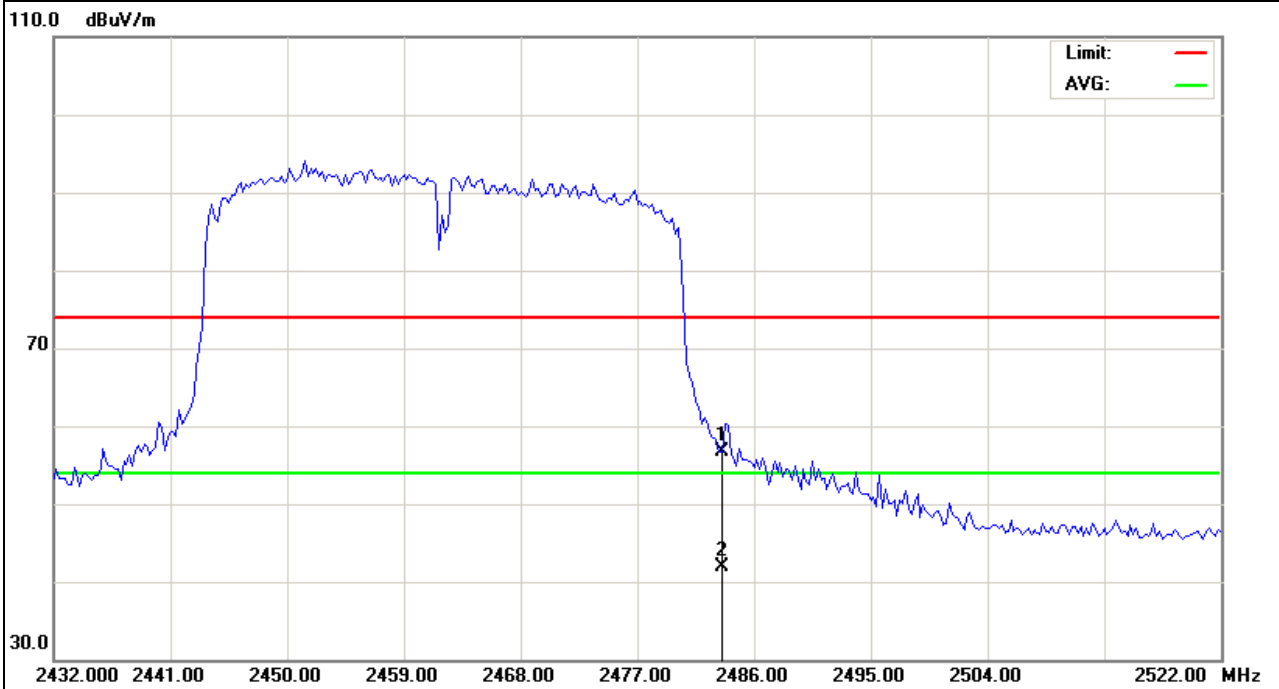

EUT :	TV BOX	Model Name :	Smartbox
Temperature :	20 °C	Relative Humidity :	48%
Pressure :	1010 hPa	Test Voltage :	DC 5V from adapter AC 120V/60Hz
Test Mode :	CH9(802.11n Mode/40MHz)	Polarization :	Vertical

Frequency (MHz)	Meter Reading (dBμV)	Factor (dB)	Emission Level (dBμV/m)	Limits (dBμV/m)	Margin (dB)	Detector Type
2483.5	71.58	-12.78	58.8	74	-15.2	peak
2483.5	54.78	-12.78	42	54	-12	AVG

Remark:  
Factor = Antenna Factor + Cable Loss – Pre-amplifier.

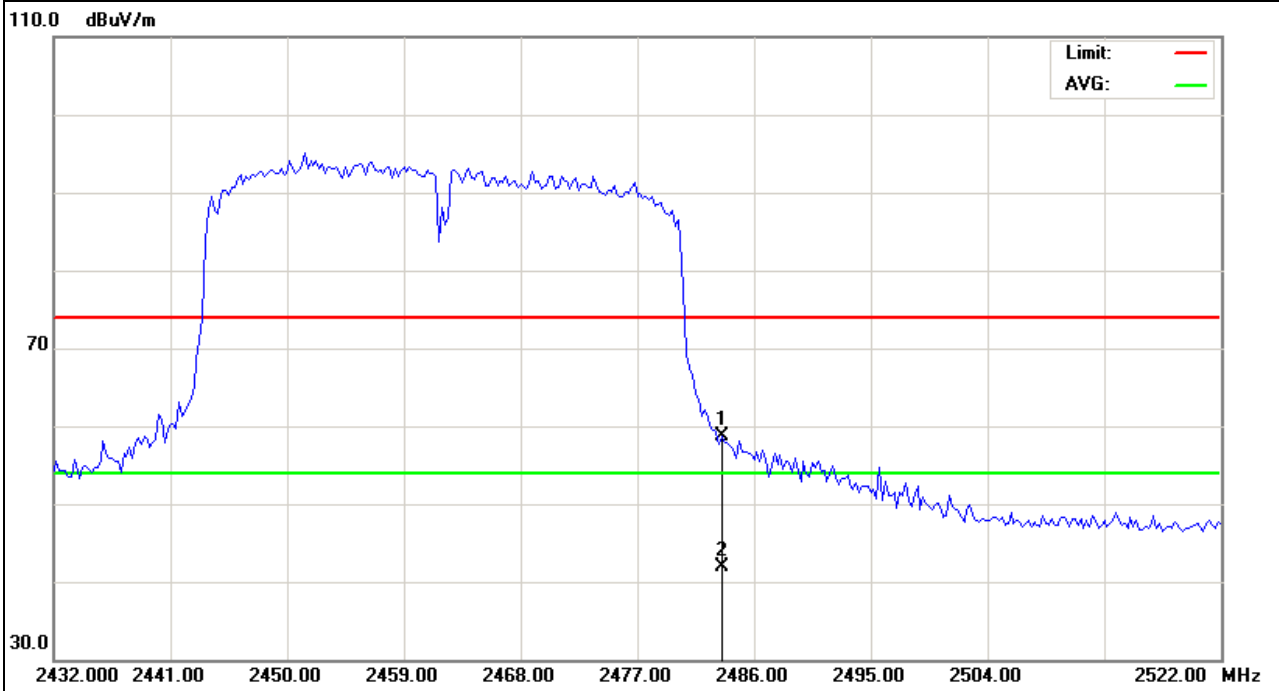

#### 4. POWER SPECTRAL DENSITY TEST

##### 4.1 APPLIED PROCEDURES / LIMIT

FCC Part15 (15.247) , Subpart C				
Section	Test Item	Limit	Frequency Range (MHz)	Result
15.247	Power Spectral Density	8 dBm (in any 3KHz)	2400-2483.5	PASS

##### 4.1.1 TEST PROCEDURE

1. Set analyzer center frequency to DTS channel center frequency.
2. Set the span to 1.5 times the DTS channel bandwidth.
3. Set the RBW  $\geq$  3 kHz.
4. Set the VBW  $\geq$  3 x RBW.
5. Detector = peak.
6. Sweep time = auto couple.
7. Trace mode = max hold.
8. Allow trace to fully stabilize.
9. Use the peak marker function to determine the maximum amplitude level.
10. If measured value exceeds limit, reduce RBW (no less than 3 kHz) and repeat.

##### 4.1.2 DEVIATION FROM STANDARD

No deviation.

##### 4.1.3 TEST SETUP



##### 4.1.4 EUT OPERATION CONDITIONS

The EUT tested system was configured as the statements of 2.1 Unless otherwise a special operating condition is specified in the follows during the testing.

### 4.1.5 TEST RESULTS

EUT :	TV BOX	Model Name :	Smartbox
Temperature :	25 °C	Relative Humidity :	60%
Pressure :	1015 hPa	Test Voltage :	DC 5V from adapter AC 120V/60Hz
Test Mode :	TX b Mode /CH01, CH06, CH11		

Frequency	Power Density A (dBm)	Power Density B (dBm)	Total Power Density (dBm)	Limit (dBm)	Result
2412 MHz	-19.52	-20.21	--	8	<b>PASS</b>
2437 MHz	-18.54	-19.23	--	8	<b>PASS</b>
2462 MHz	-17.97	-18.65	--	8	<b>PASS</b>

NOTE: Only shown A plot, the worst data.

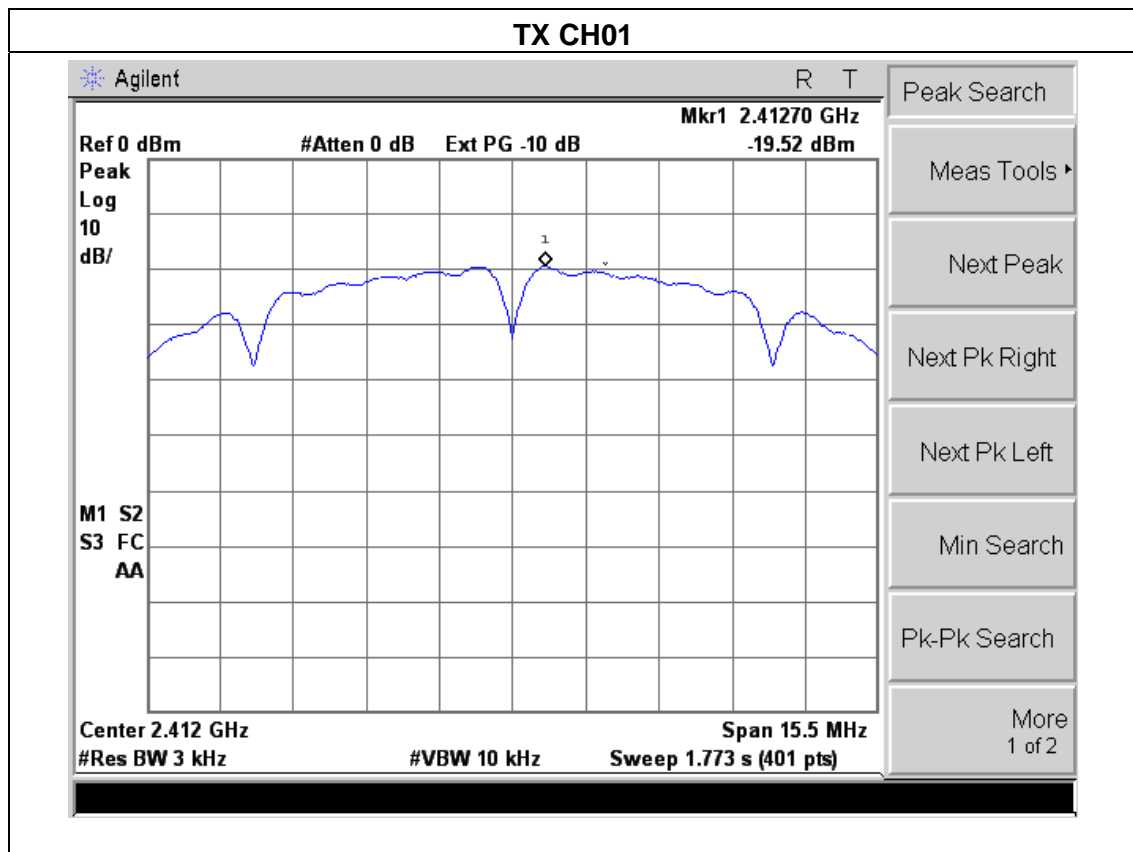



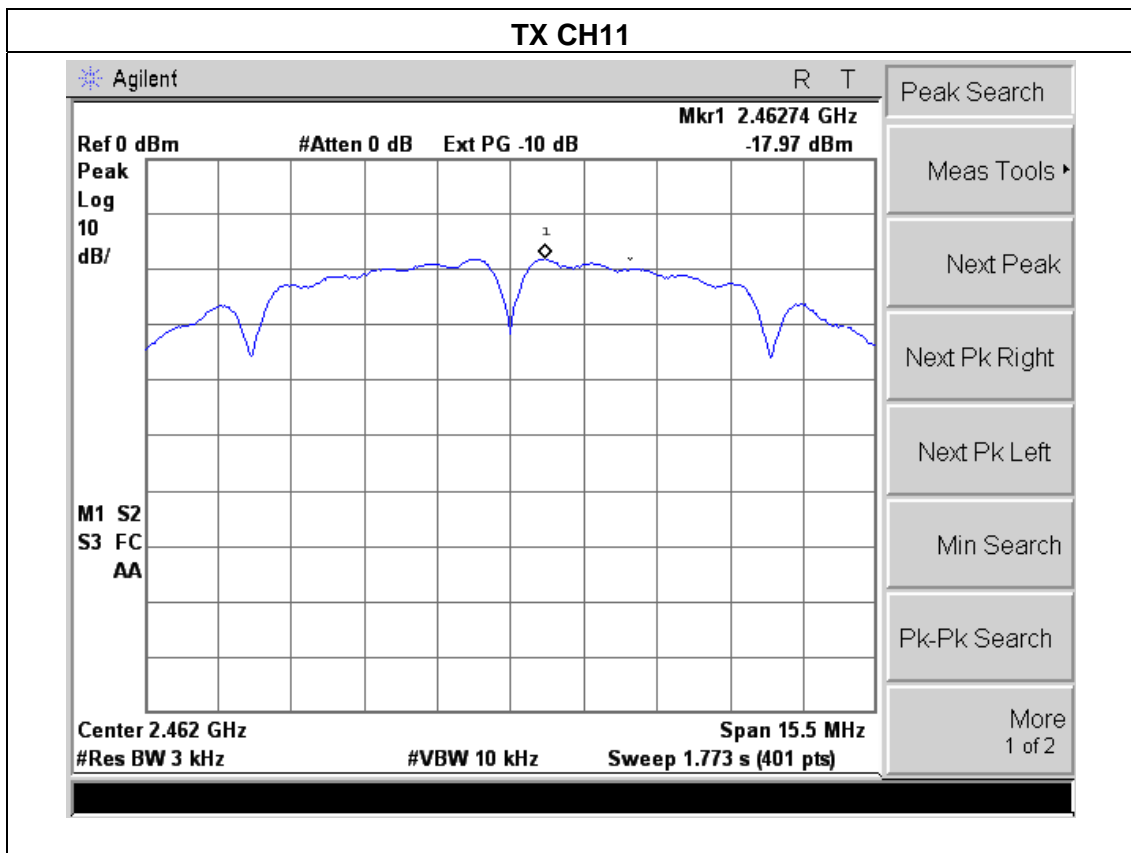
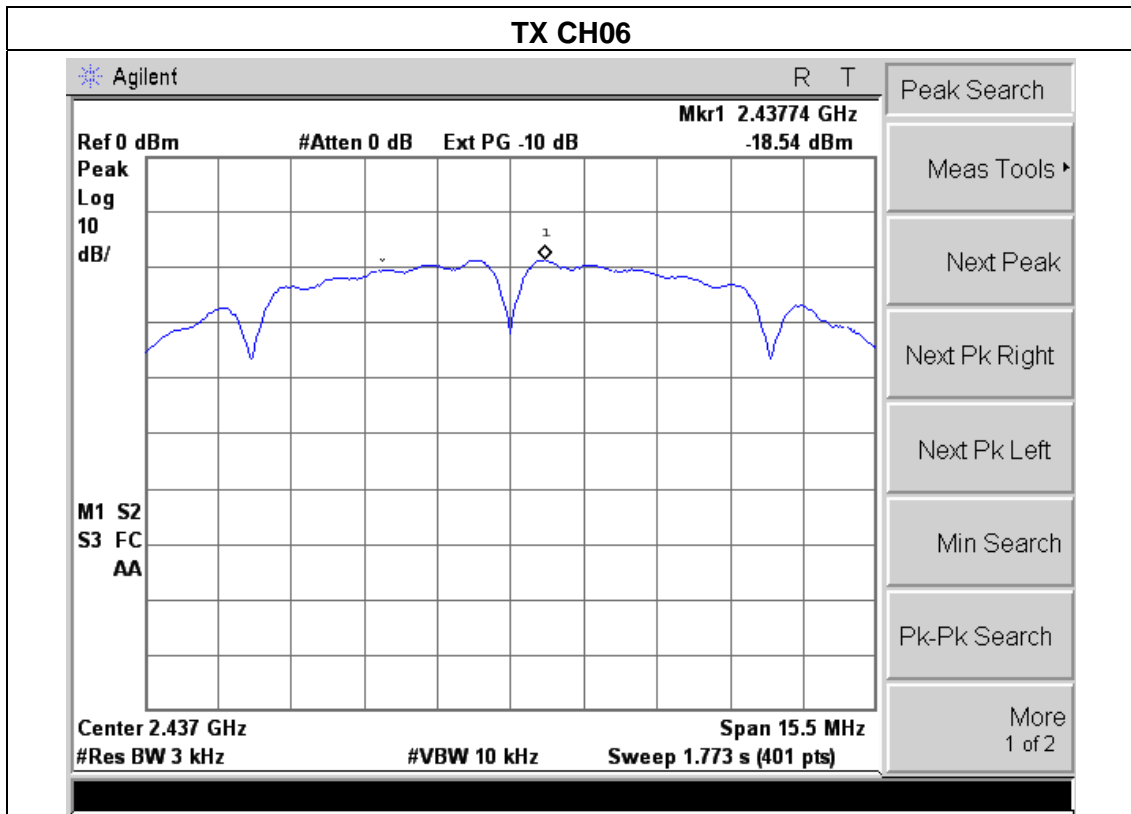

EUT :	TV BOX	Model Name :	Smartbox
Temperature :	25 °C	Relative Humidity :	60%
Pressure :	1015 hPa	Test Voltage :	DC 5V from adapter AC 120V/60Hz
Test Mode :	TX g Mode /CH01, CH06, CH11		

Frequency	Power Density A (dBm)	Power Density B (dBm)	Total Power Density (dBm)	Limit (dBm)	Result
2412 MHz	-21.50	-20.42	--	8	<b>PASS</b>
2437 MHz	-21.47	-20.65	--	8	<b>PASS</b>
2462 MHz	-20.65	-19.87	--	8	<b>PASS</b>

NOTE: Only shown A plot, the worst data.

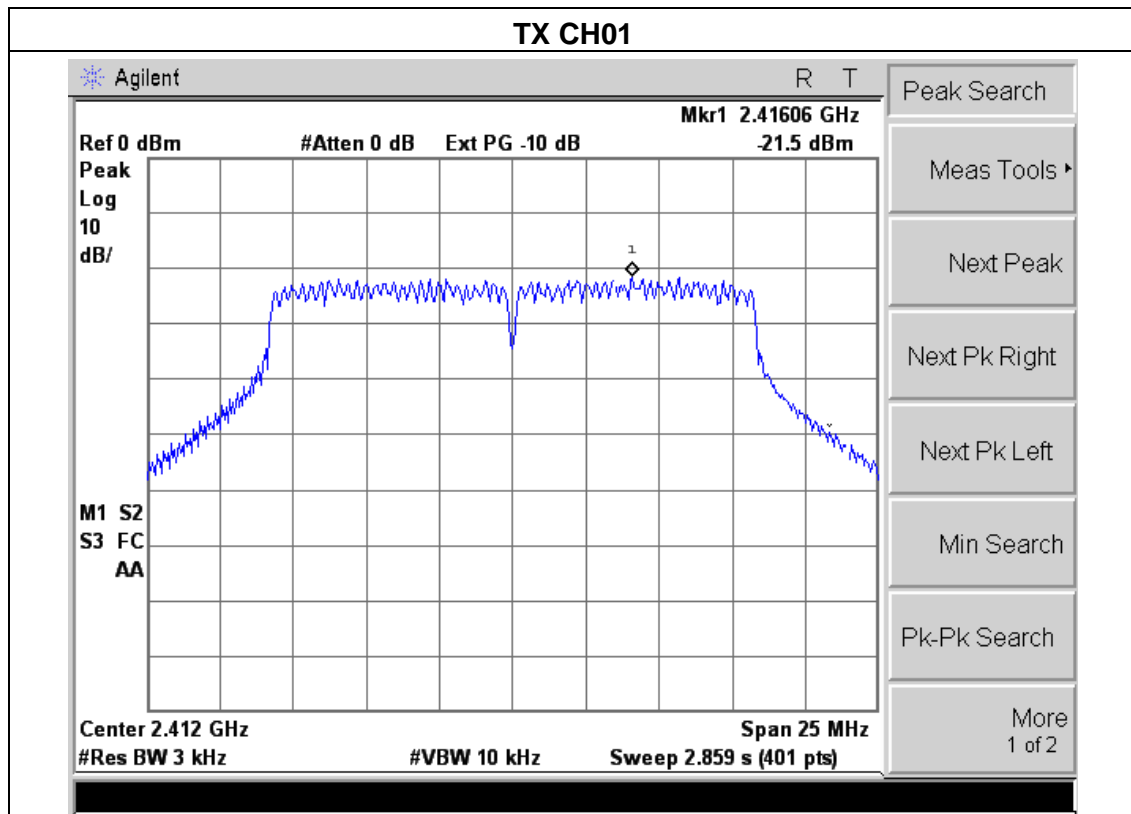

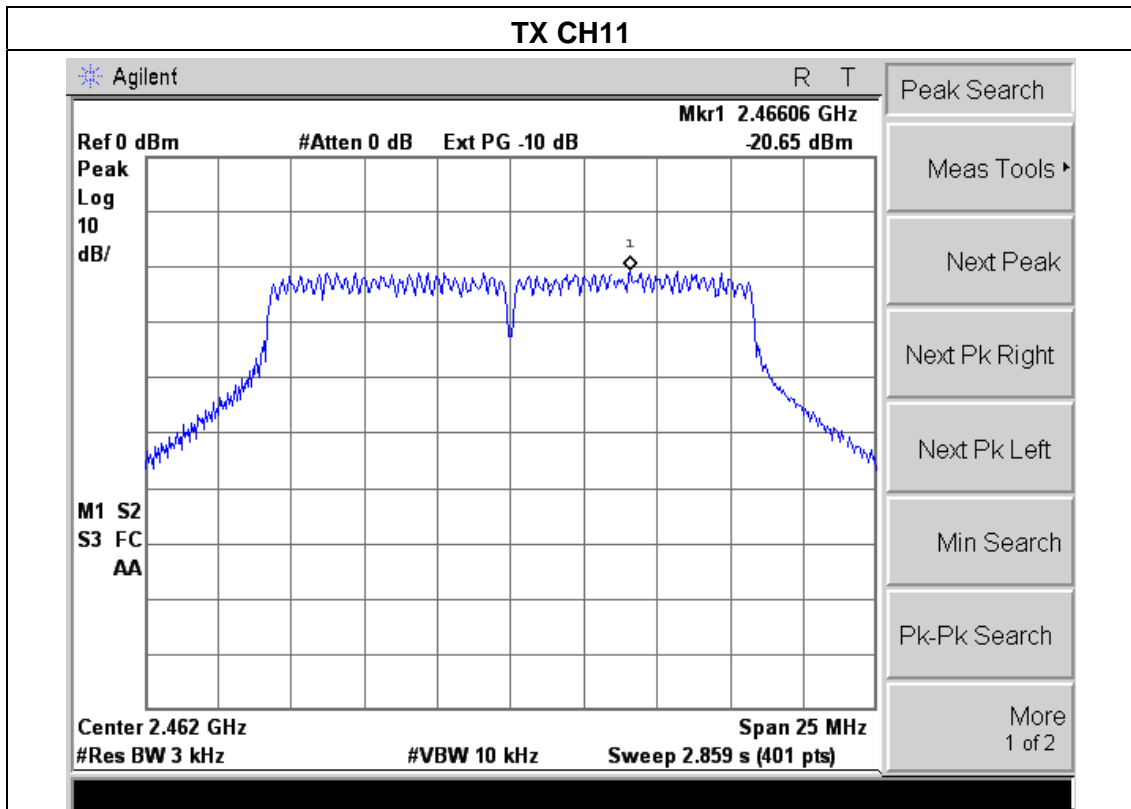
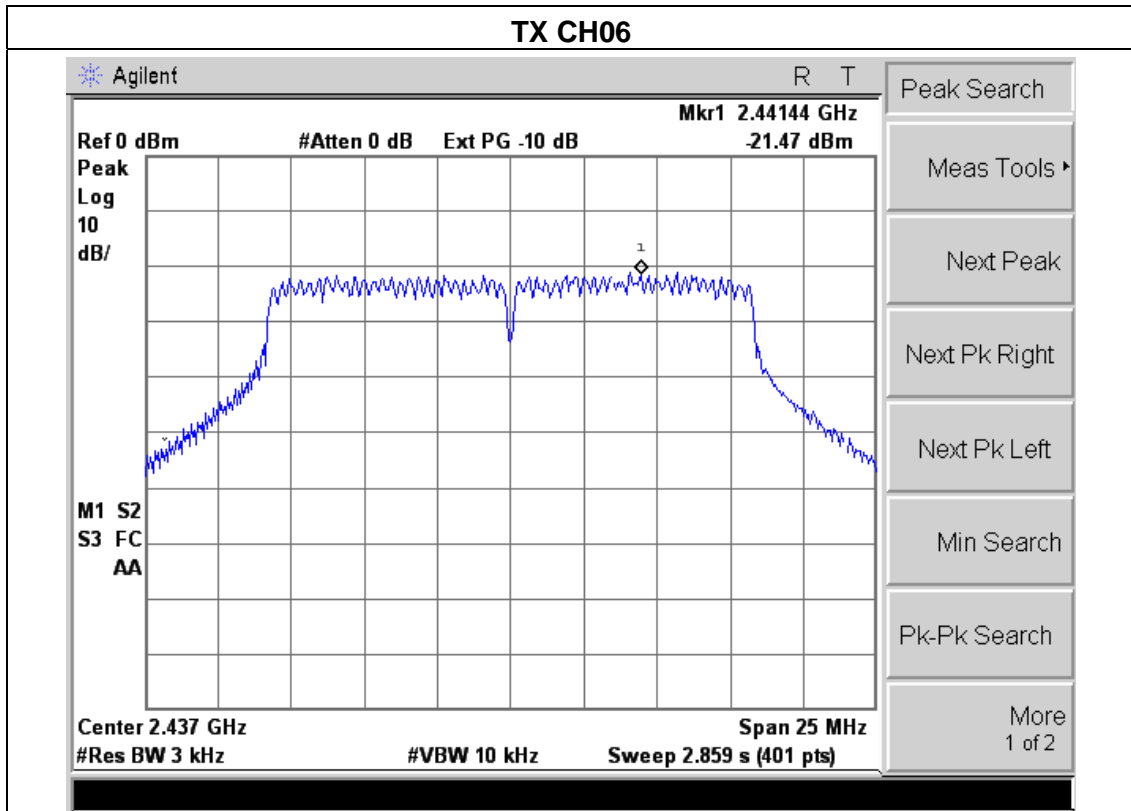

EUT :	TV BOX	Model Name :	Smartbox
Temperature :	25 °C	Relative Humidity :	60%
Pressure :	1015 hPa	Test Voltage :	DC 5V from adapter AC 120V/60Hz
Test Mode :	TX n Mode(20M) /CH01, CH06, CH11		

Frequency	Power Density A (dBm)	Power Density B (dBm)	Total Power Density (dBm)	Limit (dBm)	Result
2412 MHz	-21.18	-22.34	-18.71	8	<b>PASS</b>
2437 MHz	-21.34	-23.12	-19.13	8	<b>PASS</b>
2462 MHz	-20.26	-21.23	-17.71	8	<b>PASS</b>

NOTE: Only shown A plot, the worst data.

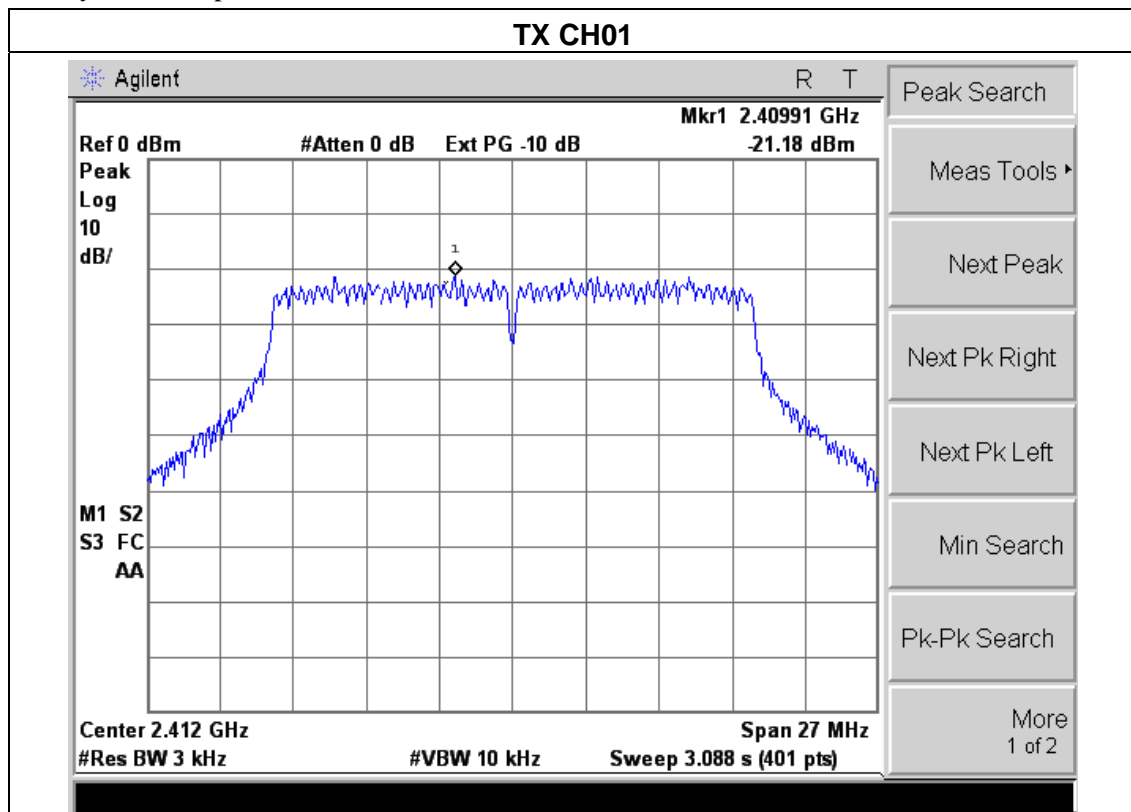

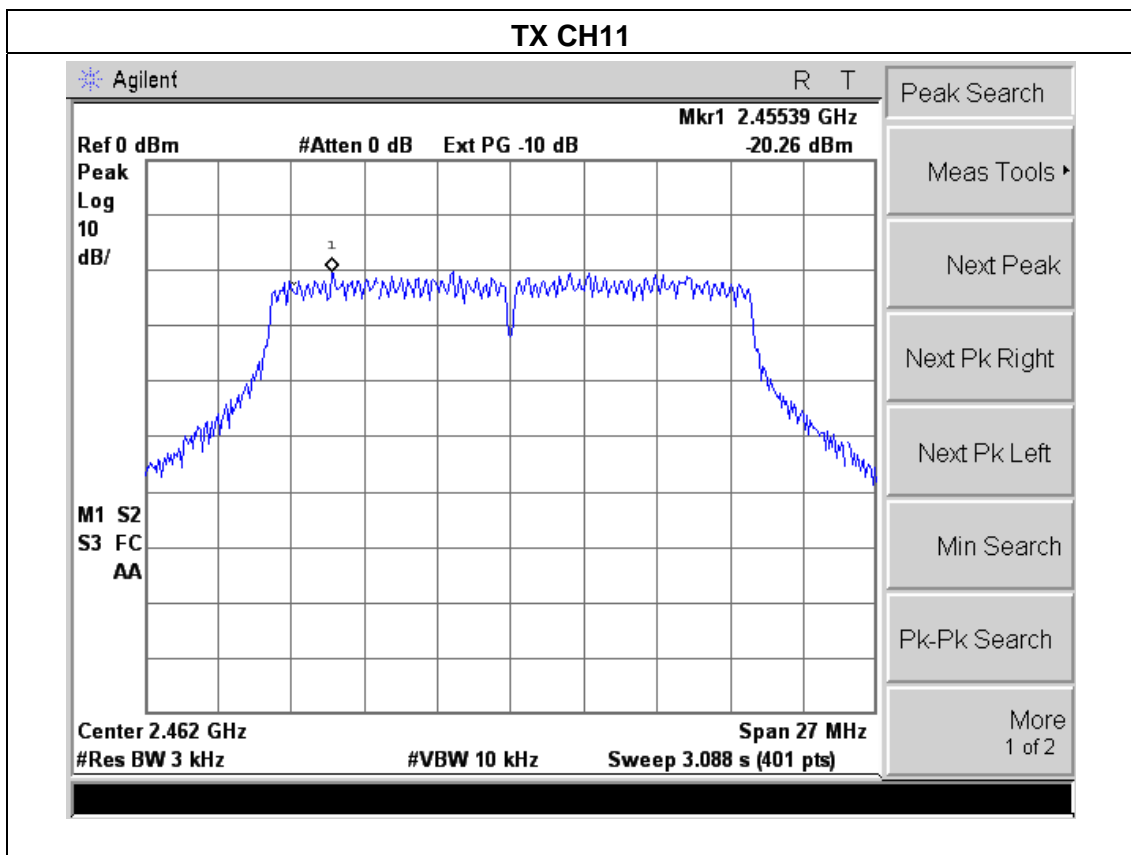
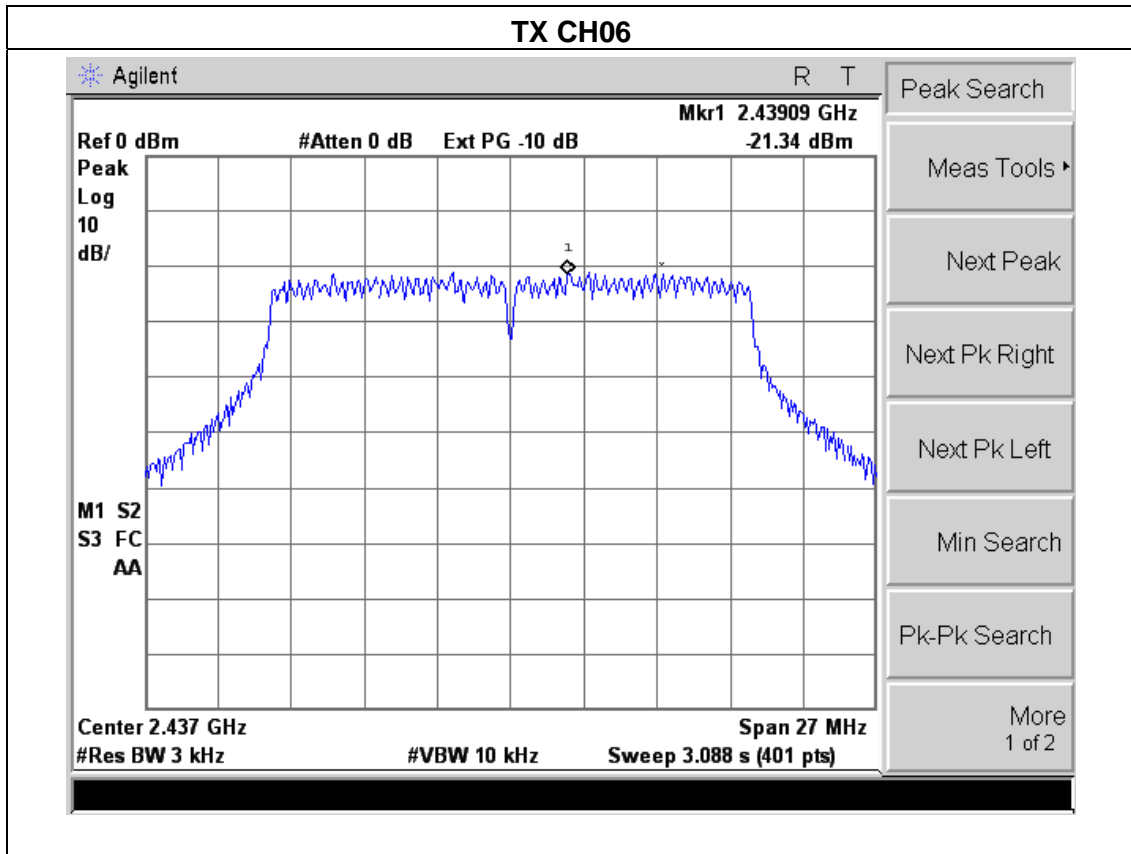

EUT :	TV BOX	Model Name :	Smartbox
Temperature :	25 °C	Relative Humidity :	60%
Pressure :	1015 hPa	Test Voltage :	DC 5V from adapter AC 120V/60Hz
Test Mode :	TX n Mode(40M) /CH03, CH06, CH09		

Frequency	Power Density A (dBm)	Power Density B (dBm)	Total Power Density (dBm)	Limit (dBm)	Result
2422 MHz	-22.00	-23.21	-19.55	8	<b>PASS</b>
2437 MHz	-20.85	-21.12	-17.97	8	<b>PASS</b>
2452 MHz	-20.15	-20.23	-17.18	8	<b>PASS</b>

NOTE: Only shown A plot, the worst data.

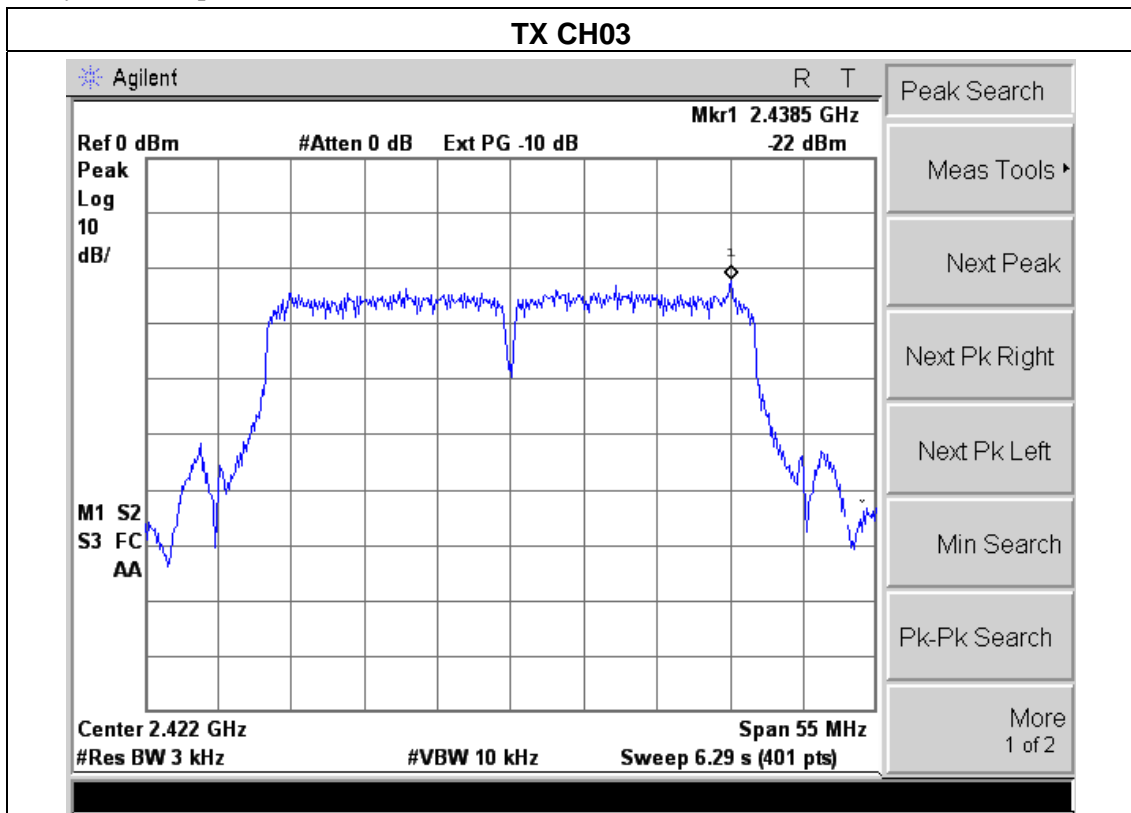

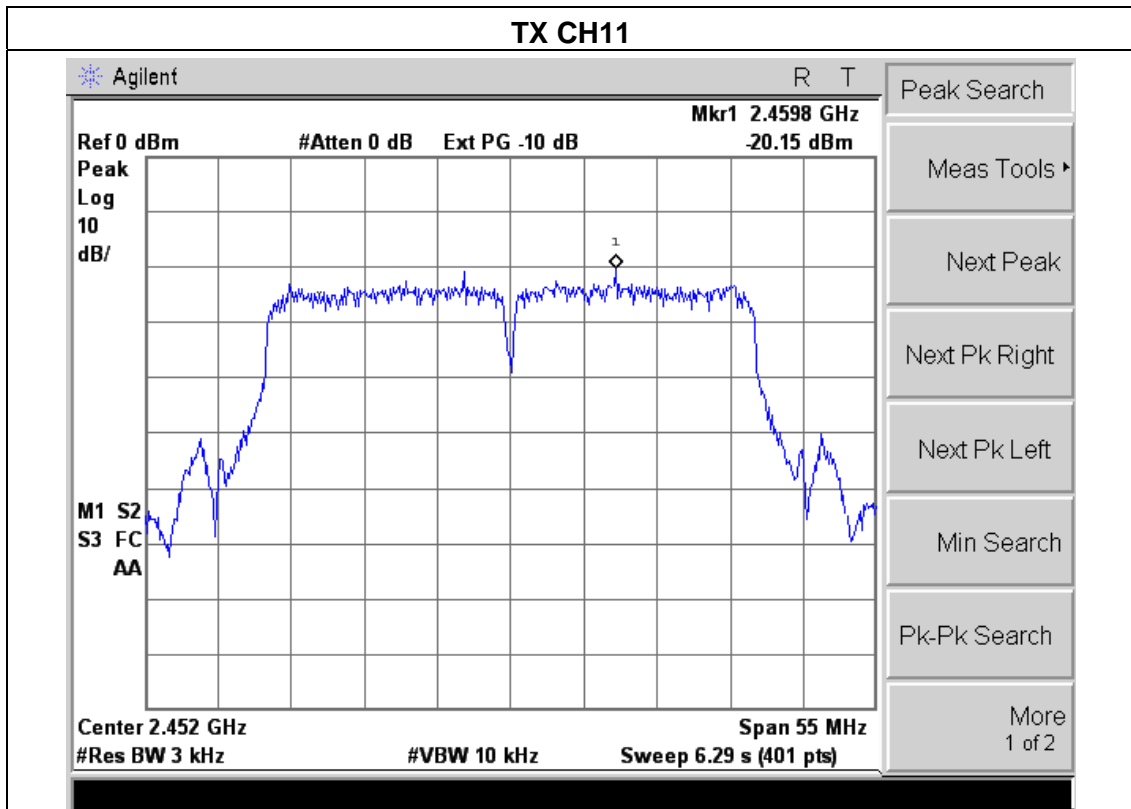
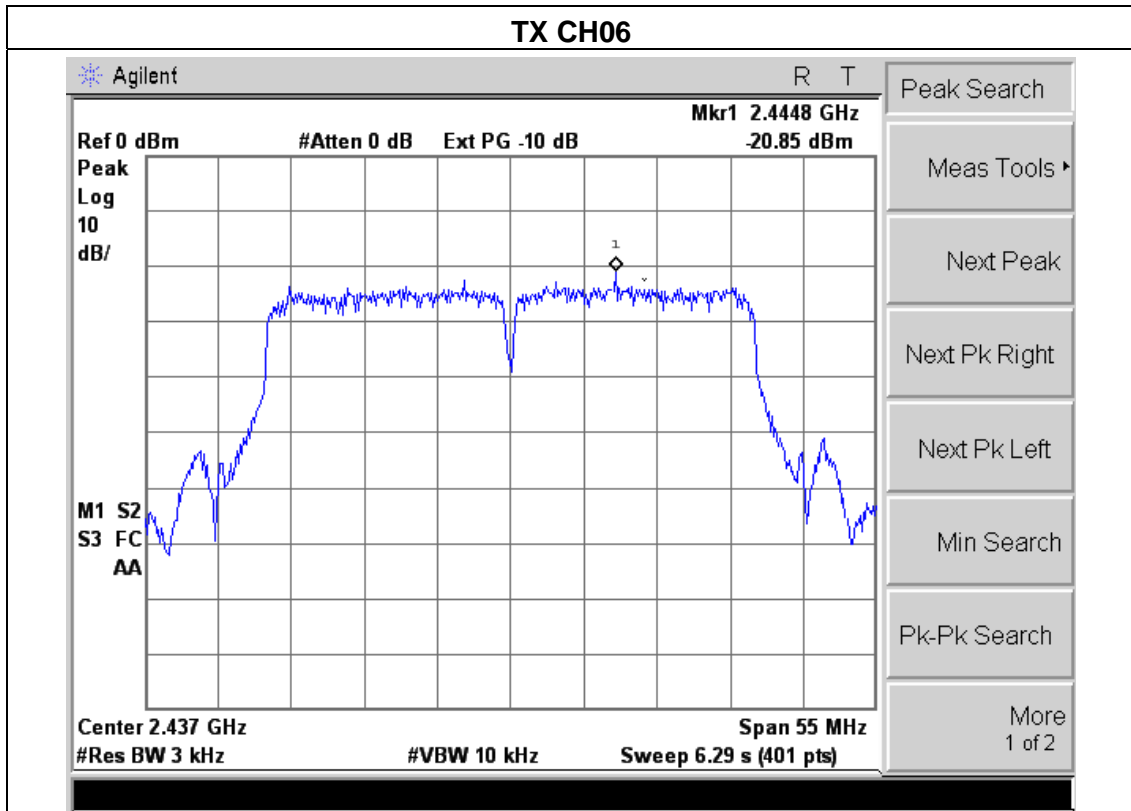

## 5. BANDWIDTH TEST

### 5.1 APPLIED PROCEDURES / LIMIT

FCC Part15 (15.247) , Subpart C				
Section	Test Item	Limit	Frequency Range (MHz)	Result
15.247(a)(2)	Bandwidth	$\geq 500\text{KHz}$ (6dB bandwidth)	2400-2483.5	PASS

#### 5.1.1 TEST PROCEDURE

a.

1. Set RBW= 100 kHz.
2. Set the video bandwidth (VBW)  $\geq 3 \times$  RBW.
3. Detector = Peak.
4. Trace mode = max hold.
5. Sweep = auto couple.
6. Allow the trace to stabilize.
7. Measure the maximum width of the emission that is constrained by the frequencies associated with the two outermost amplitude points (upper and lower) that are attenuated by 6 dB relative to the maximum level measured in the fundamental emission.

#### 5.1.2 DEVIATION FROM STANDARD

No deviation.

#### 5.1.3 TEST SETUP



#### 5.1.4 EUT OPERATION CONDITIONS

The EUT tested system was configured as the statements of 2.4 Unless otherwise a special operating condition is specified in the follows during the testing.



### 5.1.5 TEST RESULTS

EUT :	TV BOX	Model Name :	Smartbox
Temperature :	25 °C	Relative Humidity :	60%
Pressure :	1012 hPa	Test Voltage :	DC 5V from adapter AC 120V/60Hz
Test Mode :	TX b Mode /CH01, CH06, CH11		

Frequency	6dB Bandwidth (MHz)	Channel Separation (MHz)	Result
2412 MHz	10.227	>=500KHz	<b>PASS</b>
2437 MHz	9.739	>=500KHz	<b>PASS</b>
2462 MHz	10.251	>=500KHz	<b>PASS</b>

NOTE: Only shown A plot, the worst data.

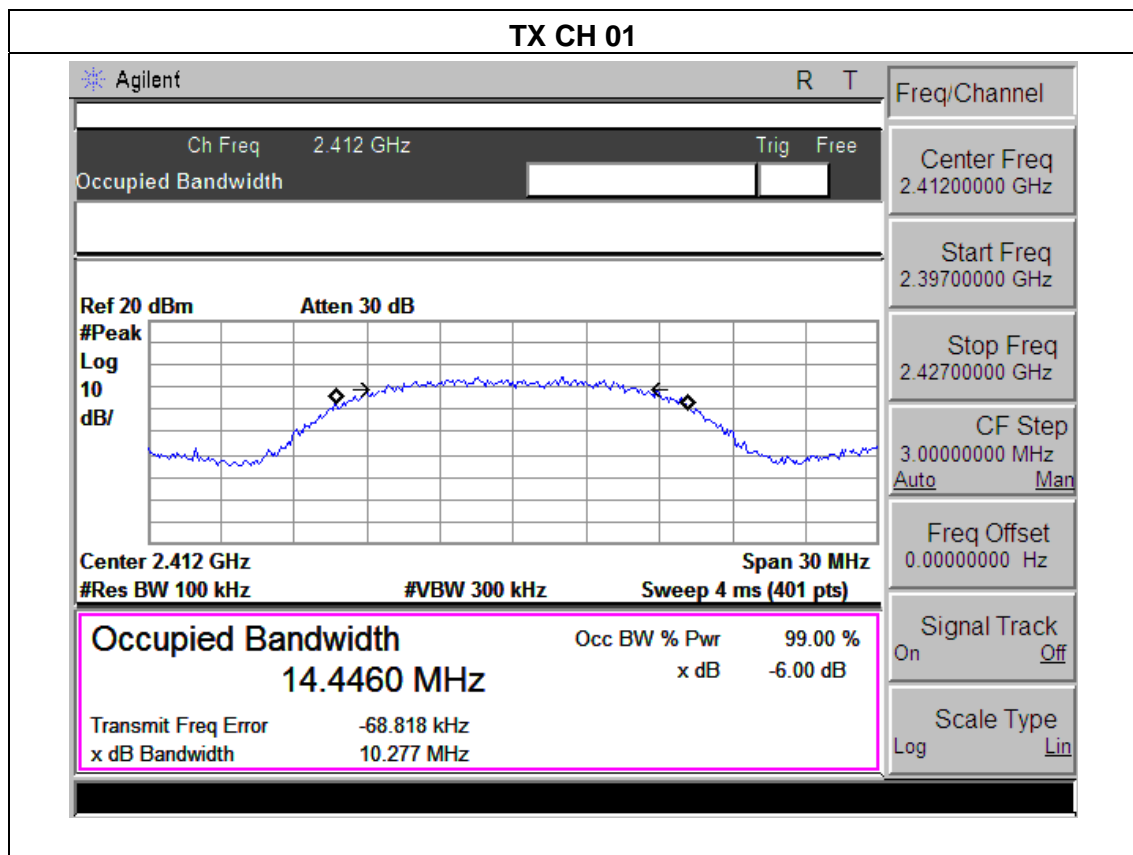

### TX CH 06

Agilent
R T

Ch Freq 2.437 GHz Trig Free

Occupied Bandwidth

Ref 20 dBm Atten 30 dB

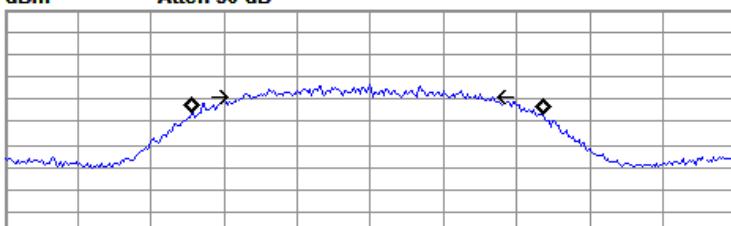
#Peak Log 10 dB/

Center 2.437 GHz Span 30 MHz  
#Res BW 100 kHz #VBW 300 kHz Sweep 4 ms (401 pts)

<b>Occupied Bandwidth</b>	Occ BW % Pwr	99.00 %
<b>14.3587 MHz</b>	x dB	-6.00 dB
Transmit Freq Error	-152.846 kHz	
x dB Bandwidth	9.739 MHz	

Meas Setup

Avg Number 10 On Off

Avg Mode Exp Repeat

Max Hold On Off

Occ BW % Pwr 99.00 %

OBW Span 30.0000000 MHz

x dB -6.00 dB

Optimize Ref Level

### TX CH 11

Agilent
R T

Ch Freq 2.462 GHz Trig Free

Occupied Bandwidth

Ref 20 dBm Atten 30 dB

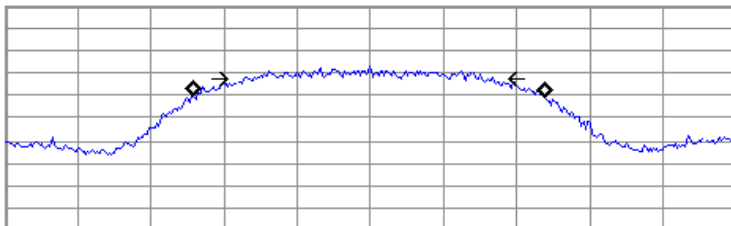
#Peak Log 10 dB/

Center 2.462 GHz Span 30 MHz  
#Res BW 100 kHz #VBW 300 kHz Sweep 4 ms (401 pts)

<b>Occupied Bandwidth</b>	Occ BW % Pwr	99.00 %
<b>14.4145 MHz</b>	x dB	-6.00 dB
Transmit Freq Error	-52.227 kHz	
x dB Bandwidth	10.251 MHz	

Freq/Channel

Center Freq 2.4620000 GHz

Start Freq 2.4470000 GHz

Stop Freq 2.4770000 GHz

CF Step 3.0000000 MHz Auto Man

Freq Offset 0.0000000 Hz

Signal Track On Off

Scale Type Log Lin

EUT :	TV BOX	Model Name :	Smartbox
Temperature :	25 °C	Relative Humidity :	60%
Pressure :	1012 hPa	Test Voltage :	DC 5V from adapter AC 120V/60Hz
Test Mode :	TX g Mode /CH01, CH06, CH11		

Frequency	6dB Bandwidth (MHz)	Channel Separation (MHz)	Result
2412 MHz	16.256	>=500KHz	<b>PASS</b>
2437 MHz	16.183	>=500KHz	<b>PASS</b>
2462 MHz	15.246	>=500KHz	<b>PASS</b>

NOTE: Only shown A plot, the worst data.

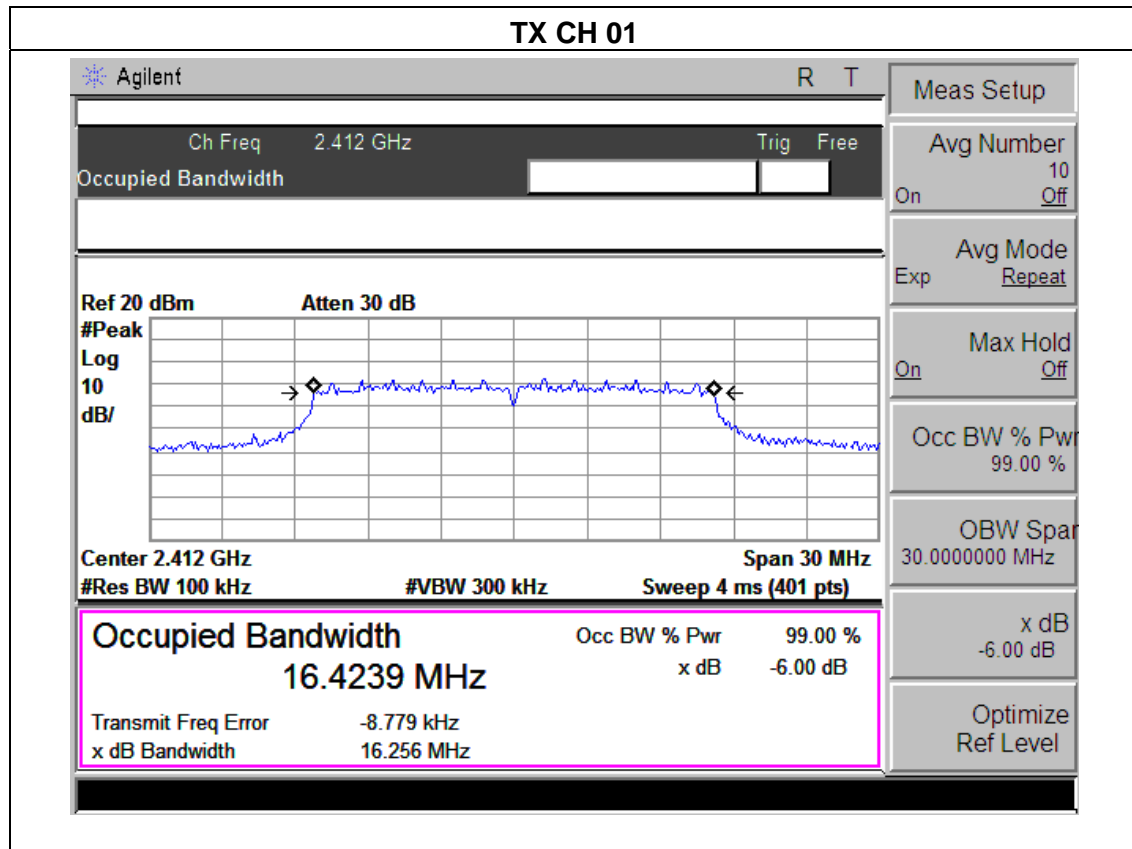

### TX CH 06

Agilent R T

Ch Freq 2.437 GHz Trig Free

Occupied Bandwidth [ ] [ ]

---

Ref 20 dBm Atten 30 dB

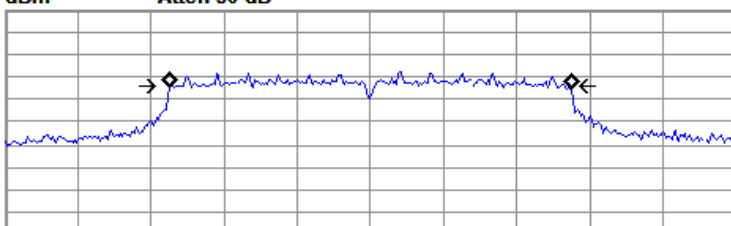

Center 2.437 GHz Span 30 MHz

#Res BW 100 kHz #VBW 300 kHz Sweep 4 ms (401 pts)

**Occupied Bandwidth** Occ BW % Pwr 99.00 %

**16.4638 MHz** x dB -6.00 dB

Transmit Freq Error 2.258 kHz

x dB Bandwidth 16.183 MHz

Freq/Channel

Center Freq 2.43700000 GHz

Start Freq 2.42200000 GHz

Stop Freq 2.45200000 GHz

CF Step 3.00000000 MHz  
Auto Man

Freq Offset 0.00000000 Hz

Signal Track On Off

Scale Type Log Lin

### TX CH 11

Agilent R T

Ch Freq 2.462 GHz Trig Free

Occupied Bandwidth [ ] [ ]

---

Ref 20 dBm Atten 30 dB

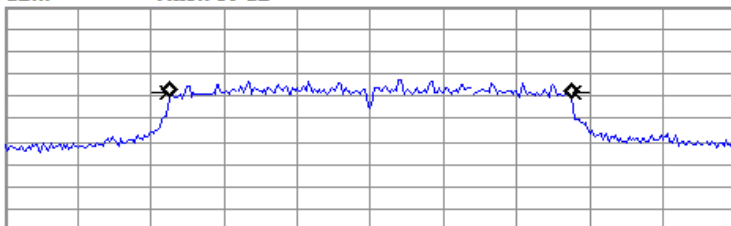

Center 2.462 GHz Span 30 MHz

#Res BW 100 kHz #VBW 300 kHz Sweep 4 ms (401 pts)

**Occupied Bandwidth** Occ BW % Pwr 99.00 %

**16.4757 MHz** x dB -6.00 dB

Transmit Freq Error 21.399 kHz

x dB Bandwidth 15.246 MHz

Meas Setup

Avg Number 10  
On Off

Avg Mode Exp Repeat

Max Hold On Off

Occ BW % Pwr 99.00 %

OBW Span 30.00000000 MHz

x dB -6.00 dB

Optimize Ref Level

EUT :	TV BOX	Model Name :	Smartbox
Temperature :	25 °C	Relative Humidity :	60%
Pressure :	1012 hPa	Test Voltage :	DC 5V from adapter AC 120V/60Hz
Test Mode :	TX n Mode(20M) /CH01, CH06, CH11		

Frequency	6dB Bandwidth (MHz)	Channel Separation (MHz)	Result
2412 MHz	16.007	>=500KHz	<b>PASS</b>
2437 MHz	15.746	>=500KHz	<b>PASS</b>
2462 MHz	16.622	>=500KHz	<b>PASS</b>

NOTE: Only shown A plot, the worst data.

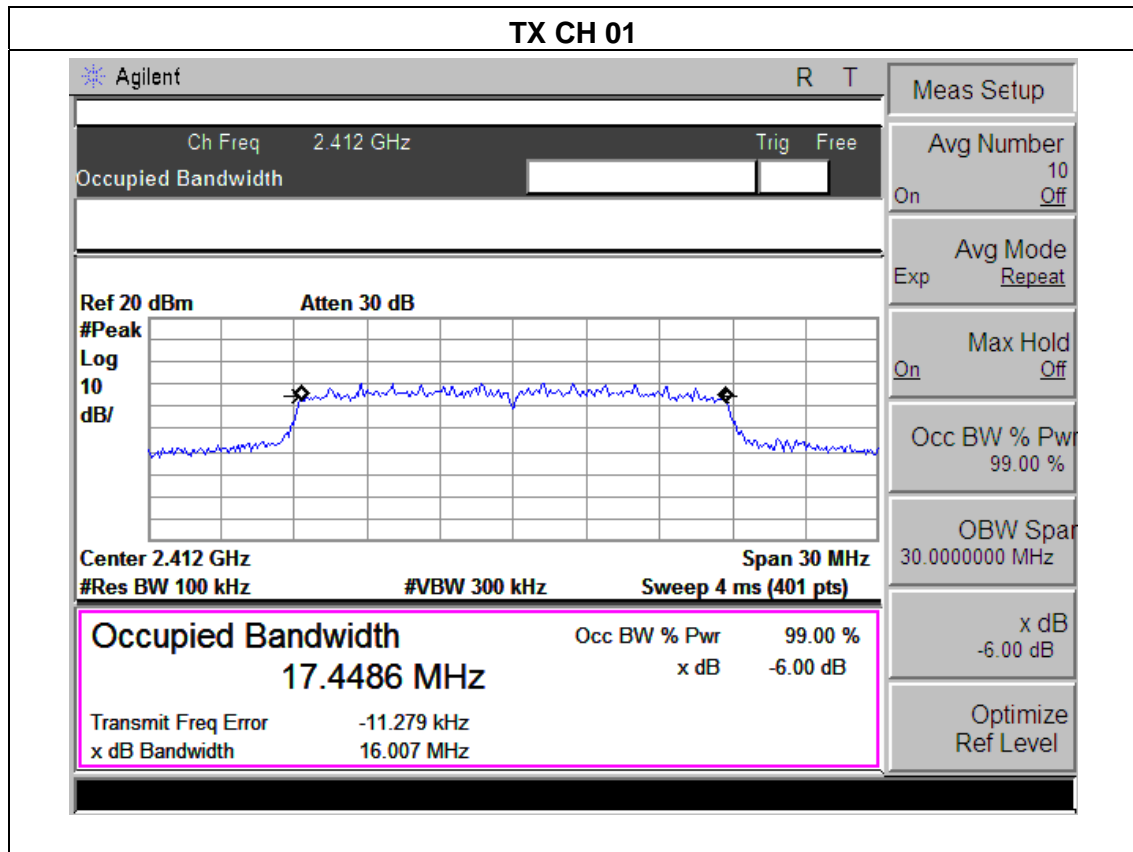

### TX CH 06

Agilent
R T

Ch Freq 2.437 GHz Trig Free

Occupied Bandwidth

Ref 20 dBm Atten 30 dB

#Peak Log 10 dB/

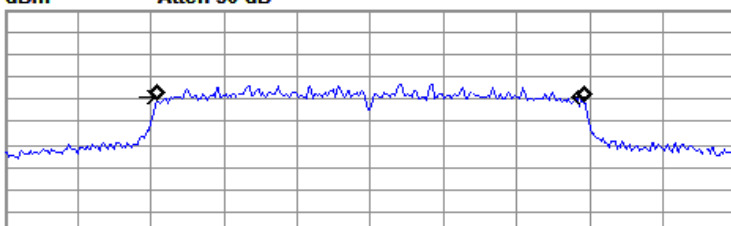

Center 2.437 GHz
Span 30 MHz

#Res BW 100 kHz
#VBW 300 kHz
Sweep 4 ms (401 pts)

<b>Occupied Bandwidth</b>	Occ BW % Pwr	99.00 %
<b>17.5318 MHz</b>	x dB	-6.00 dB
Transmit Freq Error	-3.727 kHz	
x dB Bandwidth	15.746 MHz	

Freq/Channel

Center Freq  
2.43700000 GHz

Start Freq  
2.42200000 GHz

Stop Freq  
2.45200000 GHz

CF Step  
3.00000000 MHz  
Auto Man

Freq Offset  
0.00000000 Hz

Signal Track  
On Off

Scale Type  
Log Lin

### TX CH 11

Agilent
R T

Ch Freq 2.462 GHz Trig Free

Occupied Bandwidth

Ref 20 dBm Atten 30 dB

#Peak Log 10 dB/

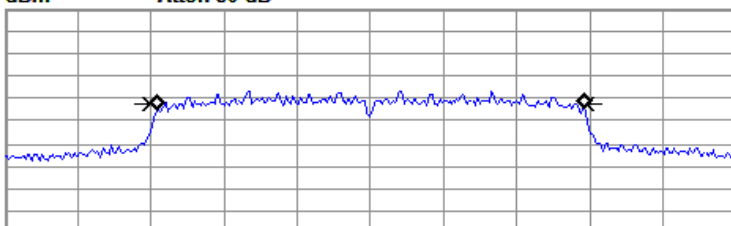

Center 2.462 GHz
Span 30 MHz

#Res BW 100 kHz
#VBW 300 kHz
Sweep 4 ms (401 pts)

<b>Occupied Bandwidth</b>	Occ BW % Pwr	99.00 %
<b>17.5233 MHz</b>	x dB	-6.00 dB
Transmit Freq Error	17.395 kHz	
x dB Bandwidth	16.622 MHz	

Freq/Channel

Center Freq  
2.46200000 GHz

Start Freq  
2.44700000 GHz

Stop Freq  
2.47700000 GHz

CF Step  
3.00000000 MHz  
Auto Man

Freq Offset  
0.00000000 Hz

Signal Track  
On Off

Scale Type  
Log Lin

EUT :	TV BOX	Model Name :	Smartbox
Temperature :	25 °C	Relative Humidity :	60%
Pressure :	1012 hPa	Test Voltage :	DC 5V from adapter AC 120V/60Hz
Test Mode :	TX n Mode(40M) /CH03, CH06, CH09		

Frequency	6dB Bandwidth (MHz)	Channel Separation (MHz)	Result
2422 MHz	35.135	>=500KHz	<b>PASS</b>
2437 MHz	33.999	>=500KHz	<b>PASS</b>
2452 MHz	35.238	>=500KHz	<b>PASS</b>

NOTE: Only shown A plot, the worst data.

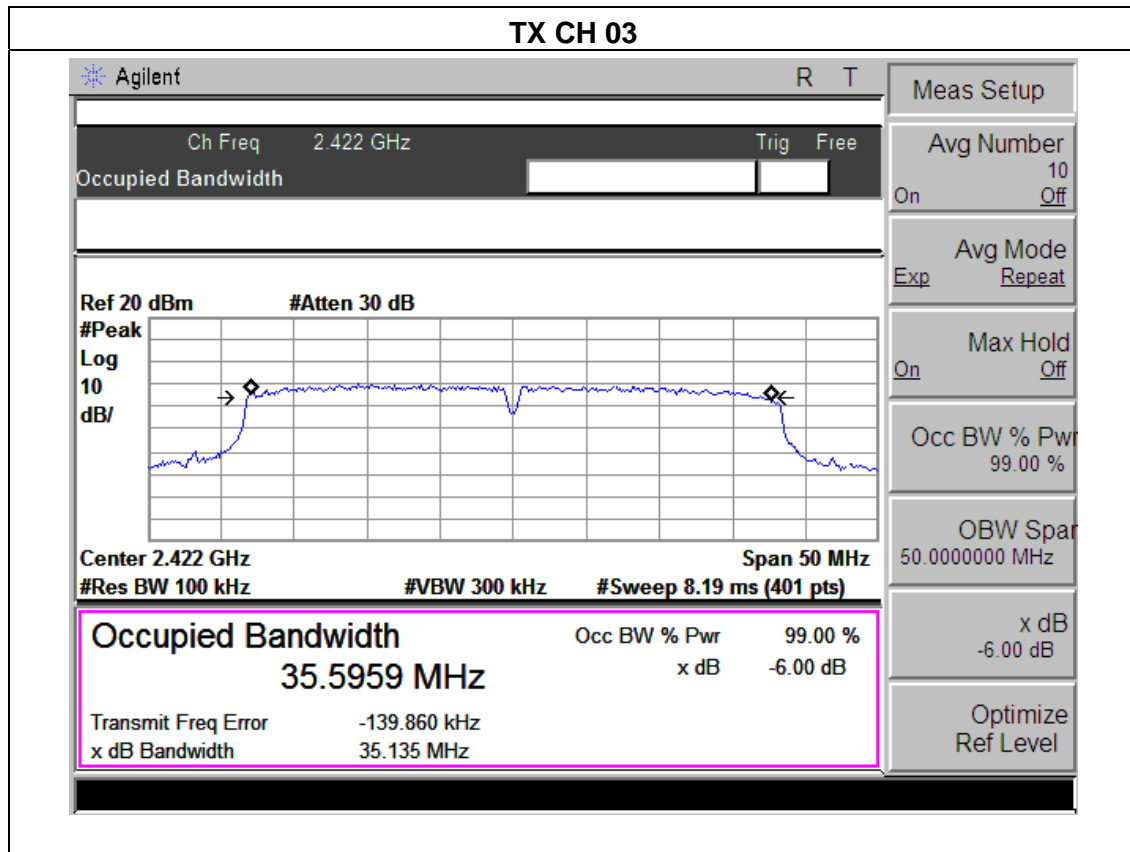

### TX CH 06

Agilent
R T

---

Ch Freq 2.437 GHz
Trig Free

Occupied Bandwidth

---

Ref 20 dBm
Atten 30 dB

#Peak
Log

10
dB/

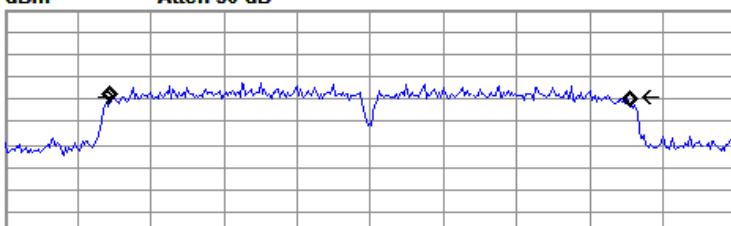

Center 2.437 GHz
Span 50 MHz

#Res BW 100 kHz
#VBW 300 kHz
Sweep 5.18 ms (401 pts)

<b>Occupied Bandwidth</b>	Occ BW % Pwr	99.00 %
<b>35.6177 MHz</b>	x dB	-6.00 dB
Transmit Freq Error	-35.462 kHz	
x dB Bandwidth	33.999 MHz	

Meas Setup  
 Avg Number 10  
 On Off  
 Avg Mode Repeat  
 Exp  
 Max Hold On Off  
 Occ BW % Pwr 99.00 %  
 OBW Span 50.0000000 MHz  
 x dB -6.00 dB  
 Optimize Ref Level

### TX CH 09

Agilent
R T

---

Ch Freq 2.452 GHz
Trig Free

Occupied Bandwidth

---

Ref 20 dBm
#Atten 30 dB

#Peak
Log

10
dB/

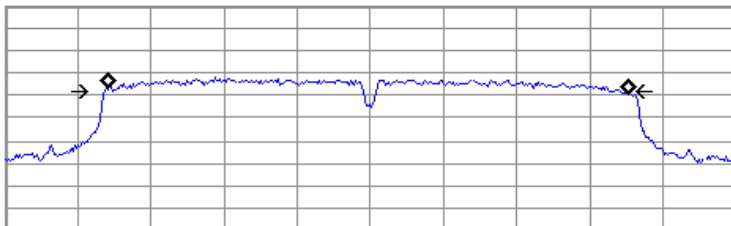

Center 2.452 GHz
Span 50 MHz

#Res BW 100 kHz
#VBW 300 kHz
#Sweep 8.19 ms (401 pts)

<b>Occupied Bandwidth</b>	Occ BW % Pwr	99.00 %
<b>35.5999 MHz</b>	x dB	-6.00 dB
Transmit Freq Error	-143.964 kHz	
x dB Bandwidth	35.283 MHz	

Freq/Channel  
 Center Freq 2.45200000 GHz  
 Start Freq 2.42700000 GHz  
 Stop Freq 2.47700000 GHz  
 CF Step 5.00000000 MHz  
 Auto Man  
 Freq Offset 0.00000000 Hz  
 Signal Track On Off  
 Scale Type Log Lin



**6. PEAK OUTPUT POWER TEST**

**6.1 APPLIED PROCEDURES / LIMIT**

FCC Part15 (15.247) , Subpart C				
Section	Test Item	Limit	Frequency Range (MHz)	Result
15.247(b)(3)	Peak Output Power	1 watt or 30dBm	2400-2483.5	PASS

**6.1.1 TEST PROCEDURE**

- a. The EUT was directly connected to the Power meter

**6.1.2 DEVIATION FROM STANDARD**

No deviation.

**6.1.3 TEST SETUP**



**6.1.4 EUT OPERATION CONDITIONS**

The EUT tested system was configured as the statements of 2.4 Unless otherwise a special operating condition is specified in the follows during the testing.

**6.1.5 TEST RESULTS**

EUT :	TV BOX	Model Name :	Smartbox
Temperature :	25 °C	Relative Humidity :	60%
Pressure :	1012 hPa	Test Voltage :	DC 5V from adapter AC 120V/60Hz
Test Mode :	TX b/g/n(20M,40M) Mode		

**TX 802.11b Mode**

Test Channe	Frequency	Peak output power. Antenna A port	Peak output power. Antenna B port	Total Power	LIMIT
	(MHz)	(dBm)	(dBm)	(dBm)	dBm
CH01	2412	22.31	21.56	--	30
CH06	2437	22.29	21.42	--	30
CH11	2462	22.26	21.31	--	30

**TX 802.11g Mode**

CH01	2412	20.53	19.87	--	30
CH06	2437	20.43	19.87	--	30
CH11	2462	20.32	19.76	--	30

**TX 802.11n/20M Mode**

CH01	2412	20.68	19.95	23.34	30
CH06	2437	20.63	19.54	23.12	30
CH11	2462	20.31	19.31	22.84	30

**TX 802.11n/40M Mode**

CH03	2422	19.95	19.57	22.77	30
CH06	2437	19.31	19.42	22.37	30
CH09	2452	19.21	19.19	22.21	30

**Note:** A .B Represent the Antenna A .B port

## **7. ANTENNA REQUIREMENT**

### **7.1 STANDARD REQUIREMENT**

15.203 requirement: For intentional device, according to 15.203: an intentional radiator shall be designed to ensure that no antenna other than that furnished by the responsible party shall be used with the device.

### **7.2 EUT ANTENNA**

This EUT uses the Integral Antennas, therefore this EUT complies with the antenna requirement

## **8. CONDUCTED SPURIOUS**

### **8.1 APPLIED PROCEDURES / LIMIT**

According to FCC section 15.247(d), in any 100kHz bandwidth outside the frequency band in which the spread spectrum or digitally modulated intentional radiator is operating, the radio frequency power that is produced by the intentional radiator shall be at least 20dB below that in the 100kHz bandwidth within the band that contains the highest level of the desired power, based on either an RF conducted or a radiated measurement

### **8.2 TEST PROCEDURE**

- a) Check the calibration of the measuring instrument using either an internal calibrator or a known signal from an external generator.
- b) Position the EUT without connection to measurement instrument. Turn on the EUT and connect its antenna terminal to measurement instrument via a low loss cable. Then set it to any one measured frequency within its operating range, and make sure the instrument is operated in its linear range.
- c) Set RBW to 100 kHz and VBW of spectrum analyzer to 300 kHz with a convenient frequency span including 100 kHz bandwidth from band edge.
- d) Measure the highest amplitude appearing on spectral display and set it as a reference level. Plot the graph with marking the highest point and edge frequency.
- e) Repeat above procedures until all measured frequencies were complete.

### **8.3 DEVIATION FROM STANDARD**

No deviation.

### **8.4 TEST SETUP**



### **8.5 EUT OPERATION CONDITIONS**

The EUT tested system was configured as the statements of 2.4 Unless otherwise a special operating condition is specified in the follows during the testing.

### 8.6 TEST RESULTS

EUT :	TV BOX	Model Name :	Smartbox
Temperature :	25 °C	Relative Humidity :	60%
Pressure :	1012 hPa	Test Voltage :	AC 120V

802.11b/CH1

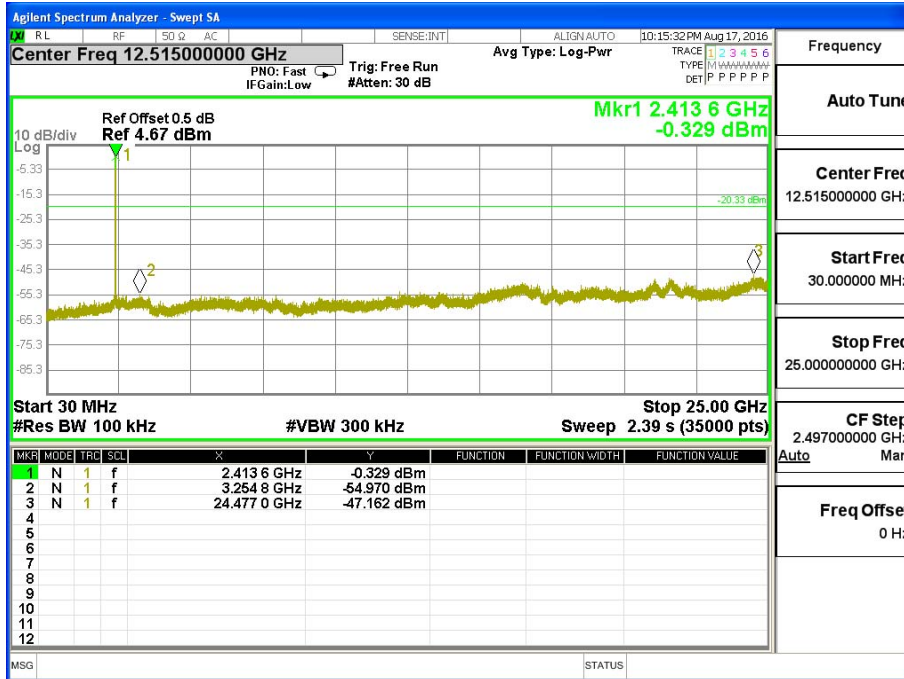

802.11b/CH6

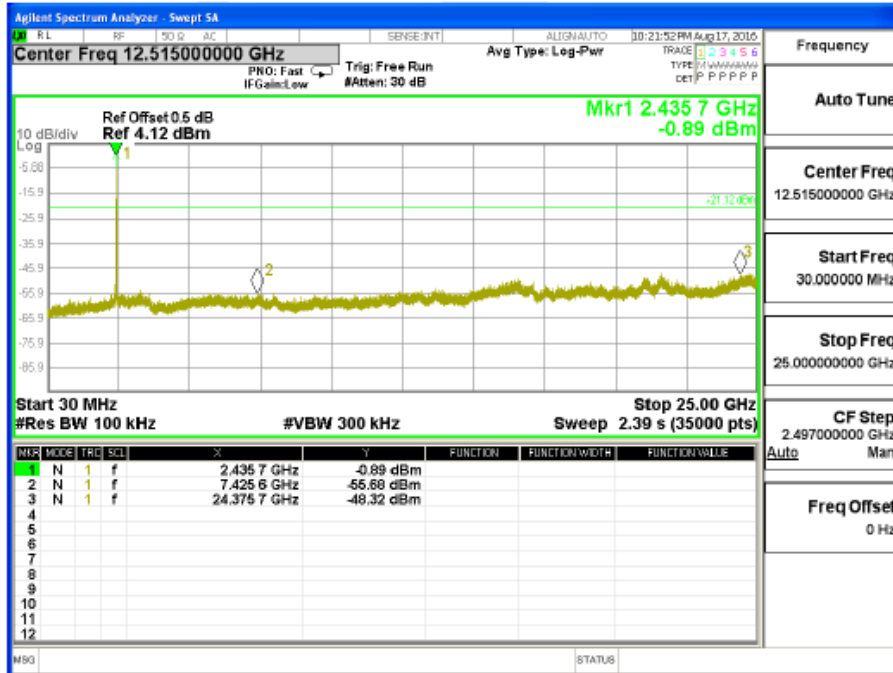

### 802.11b/CH11

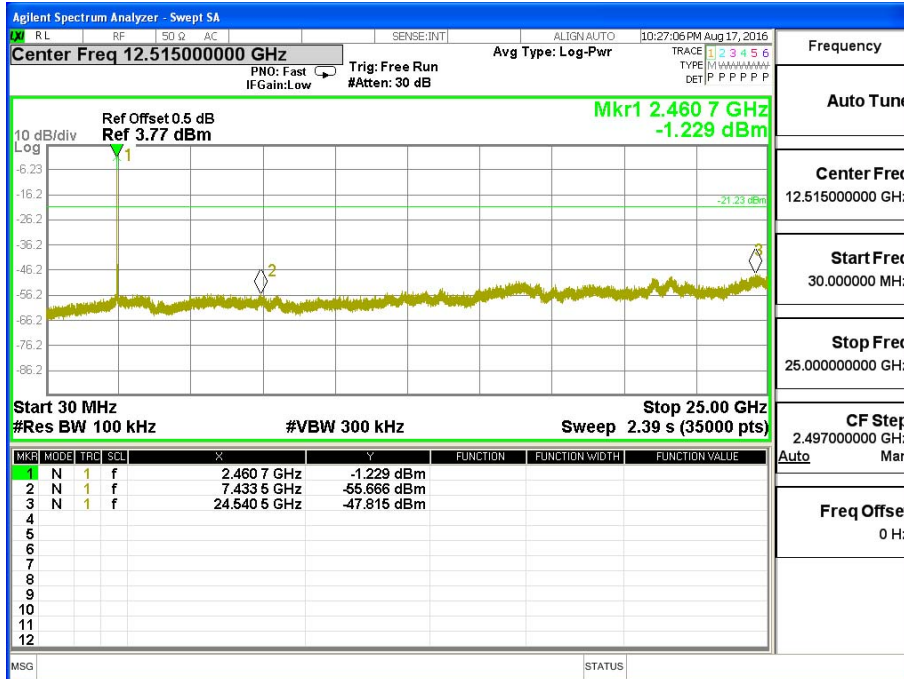

### 802.11g/CH1

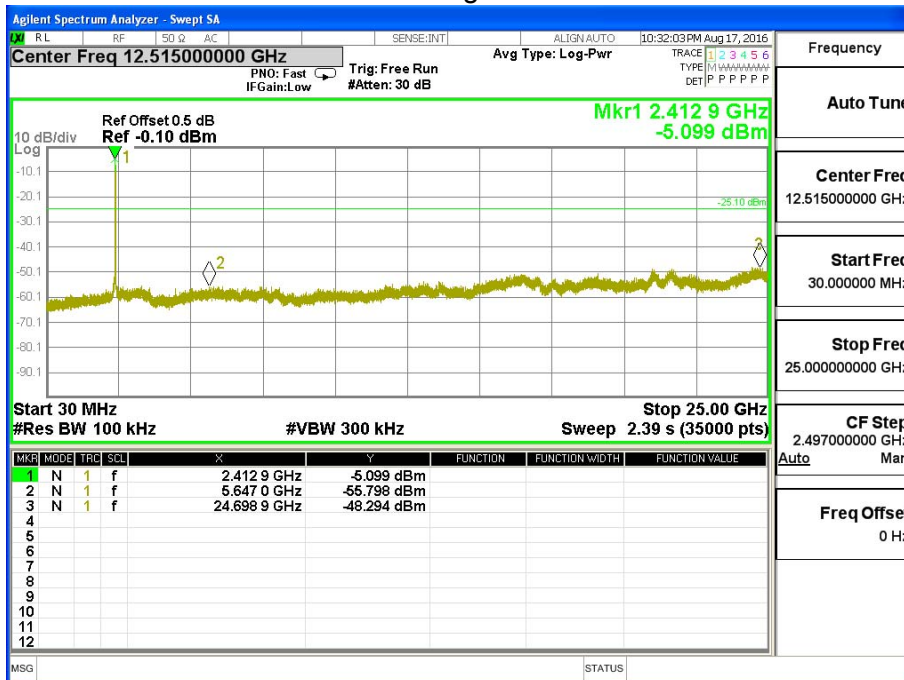

### 802.11g/CH6

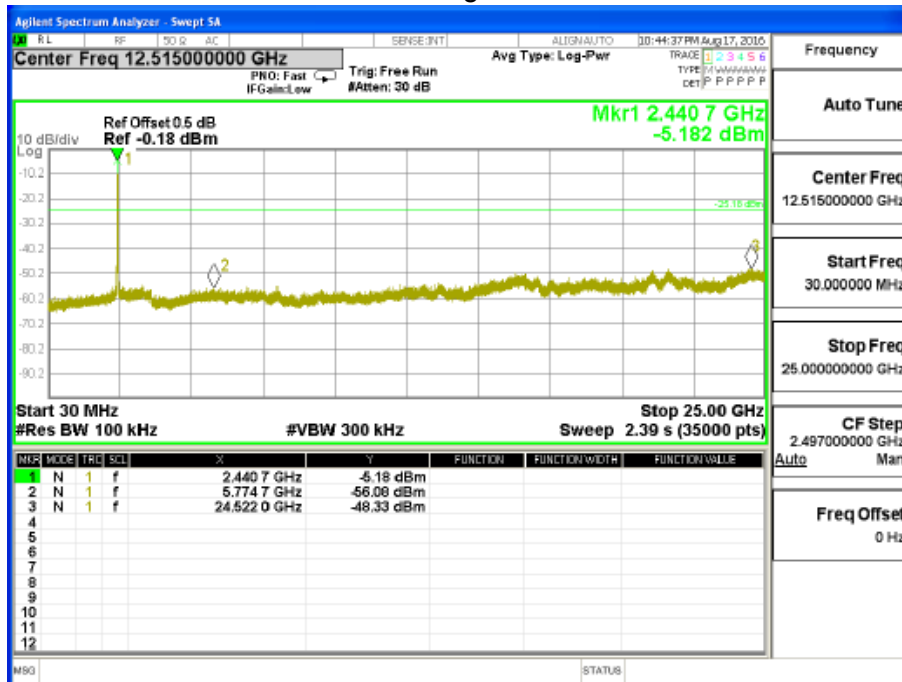

### 802.11g/CH11

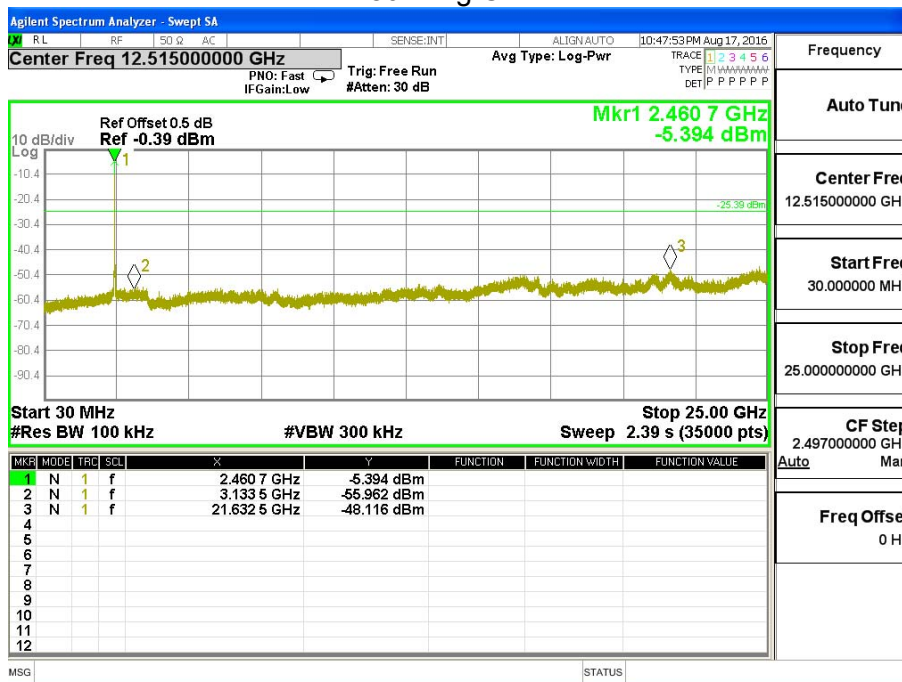

### 802.11n(20)/CH1

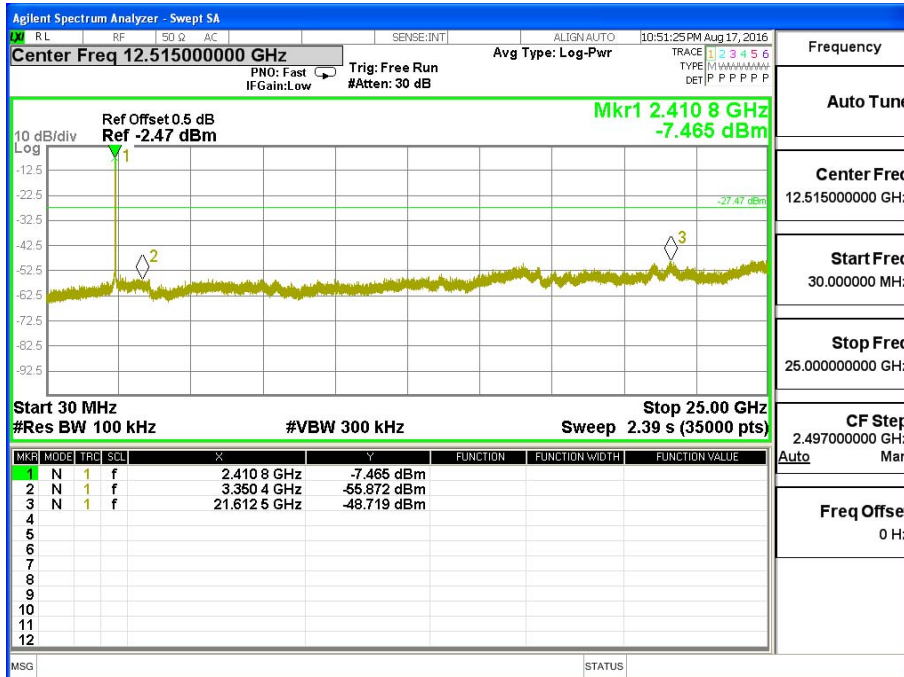

### 802.11n(20)/CH6

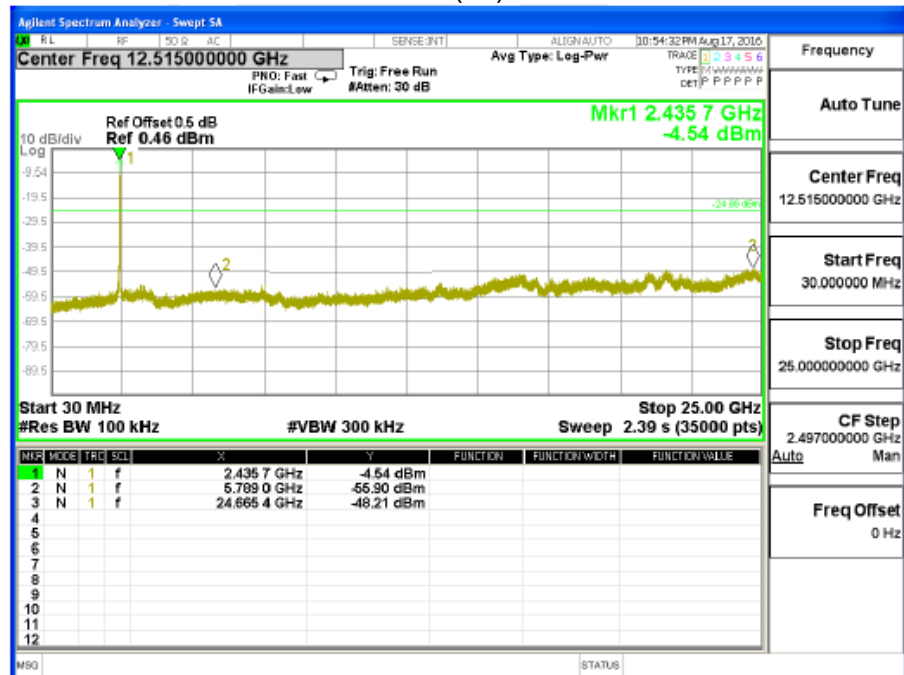



### 802.11n(20)/CH11

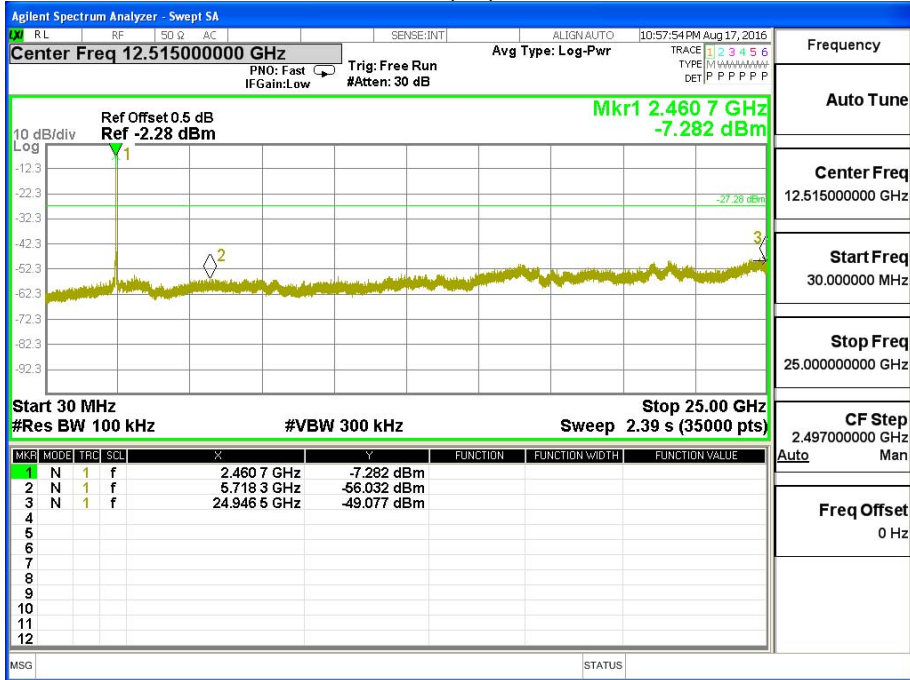

### 802.11n(40)/CH3

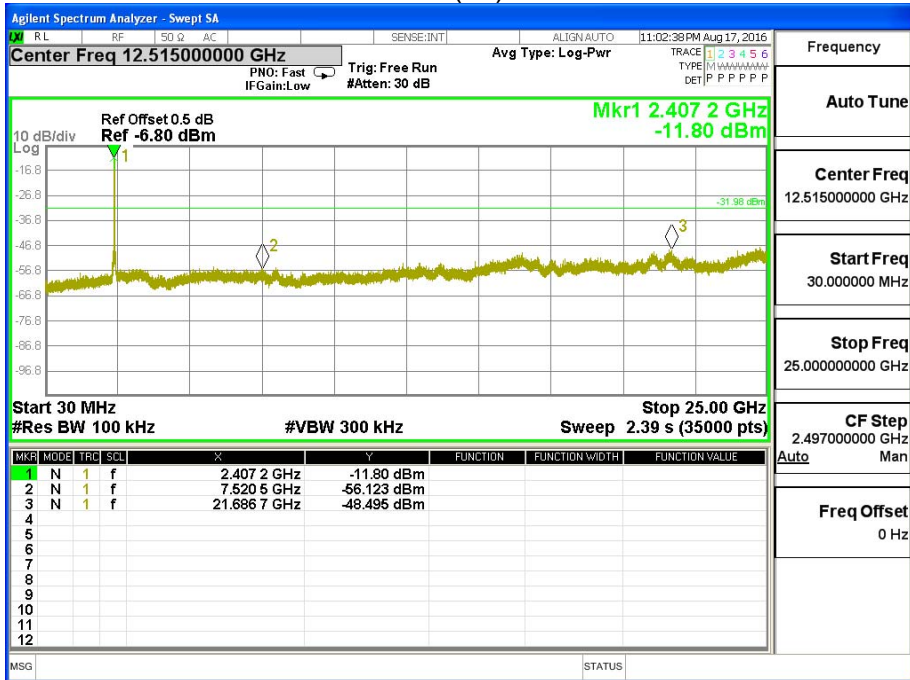

### 802.11n(40)/CH6

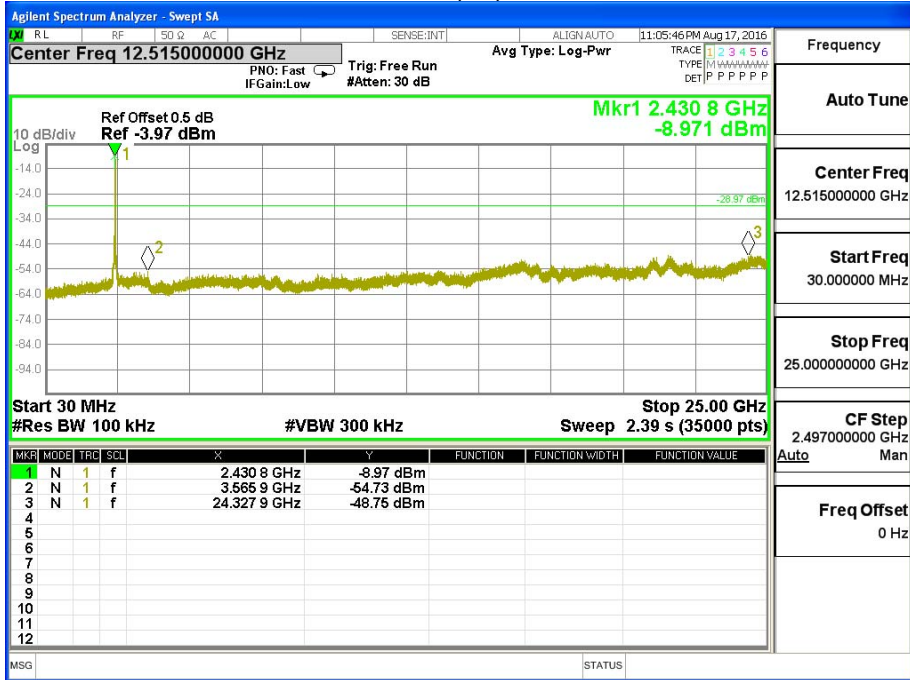

### 802.11n(40)/CH9

