

FCC REPORT

Applicant: Shenzhen RodinBell Technology Co., Ltd.

Address of Applicant: 905#, Tower B, Xinghe WORLD, Wuhe Avenue, Longgang District, Shenzhen City, PRC

Equipment Under Test (EUT)

Product Name: ORCA-50 Handheld Data Terminal

Model No.: ORCA-50

FCC ID: 2AKQD-ORCA-50

Applicable standards: FCC CFR Title 47 Part 15 Subpart C Section 15.247

Date of sample receipt: 19 Dec., 2016

Date of Test: 19 Dec., 2016 to 28 Mar., 2017

Date of report issued: 28 Mar., 2017

Test Result: PASS *

* In the configuration tested, the EUT complied with the standards specified above.

Authorized Signature:



Bruce Zhang
Laboratory Manager

This report details the results of the testing carried out on one sample. The results contained in this test report do not relate to other samples of the same product and does not permit the use of the CCIS product certification mark. The manufacturer should ensure that all products in series production are in conformity with the product sample detailed in this report.

This report may only be reproduced and distributed in full. If the product in this report is used in any configuration other than that detailed in the report, the manufacturer must ensure the new system complies with all relevant standards.

This document cannot be reproduced except in full, without prior written approval of the Company. Any unauthorized alteration, forgery or falsification of the content or appearance of this document is unlawful and offenders may be prosecuted to the fullest extent of the law. Unless otherwise stated the results shown in this test report refer only to the sample(s) tested and such sample(s) are retained for 90 days only.

2 Version

Version No.	Date	Description
00	28 Mar., 2017	Original

Prepared by:

Carrey Chen

Report Clerk

Date:

28 Mar., 2017

Reviewed by:

Ryan Lee

Project Engineer

Date:

28 Mar., 2017

3 Contents

	Page
1 COVER PAGE.....	1
2 VERSION	2
3 CONTENTS	3
4 TEST SUMMARY.....	4
5 GENERAL INFORMATION.....	5
5.1 CLIENT INFORMATION	5
5.2 GENERAL DESCRIPTION OF E.U.T.	5
5.3 TEST MODE	7
5.4 LABORATORY FACILITY	7
5.5 LABORATORY LOCATION	7
5.6 DESCRIPTION OF SUPPORT UNITS	7
5.7 TEST INSTRUMENTS LIST.....	8
6 TEST RESULTS AND MEASUREMENT DATA.....	10
6.1 ANTENNA REQUIREMENT	10
6.2 CONDUCTED EMISSIONS	11
6.3 CONDUCTED OUTPUT POWER.....	14
6.4 20dB OCCUPY BANDWIDTH.....	16
6.5 CARRIER FREQUENCIES SEPARATION.....	18
6.6 HOPPING CHANNEL NUMBER	20
6.7 DWELL TIME.....	22
6.8 PSEUDORANDOM FREQUENCY HOPPING SEQUENCE.....	24
6.9 BAND EDGE.....	25
6.9.1 Conducted Emission Method.....	25
6.10 SPURIOUS EMISSION	27
6.10.1 Conducted Emission Method.....	27
6.10.2 Radiated Emission Method	30
7 TEST SETUP PHOTO	35
8 EUT CONSTRUCTIONAL DETAILS.....	36

4 Test Summary

Test Item	Section in CFR 47	Result
Antenna Requirement	15.203/15.247 (c)	Pass
AC Power Line Conducted Emission	15.207	Pass
Conducted Peak Output Power	15.247 (b)(2)	Pass
20dB Occupied Bandwidth	15.247 (a)(1)	Pass
Carrier Frequencies Separation	15.247 (a)(1)	Pass
Hopping Channel Number	15.247 (a)(1)	Pass
Dwell Time	15.247 (a)(1)	Pass
Radiated Emission	15.205/15.209/15.247(d)	Pass
Band Edge	15.209/15.247(d)	Pass

Pass: The EUT complies with the essential requirements in the standard.

5 General Information

5.1 Client Information

Applicant:	Shenzhen RodinBell Technology Co., Ltd.
Address of Applicant:	905#, Tower B, Xinghe WORLD, Wuhe Avenue, Longgang District, Shenzhen City, PRC
Manufacturer:	Shenzhen RodinBell Technology Co., Ltd.
Address of Manufacturer:	905#, Tower B, Xinghe WORLD, Wuhe Avenue, Longgang District, Shenzhen City, PRC

5.2 General Description of E.U.T.

Product Name:	ORCA-50 Handheld Data Terminal
Model No.:	ORCA-50
Operation Frequency:	902.5MHz~927.5MHz
Number of channel:	50
Modulation type:	GFSK
Modulation technology:	FHSS
Antenna Type:	PCB Antenna
Antenna gain:	3dBi
Power supply:	Rechargeable Li-ion Battery DC3.7V-6000mAh
AC adapter:	Model: HKC0115020-2B Input: AC100-240V 50/60Hz 0.5A Output: DC 5.0V, 2A

Operation Frequency each of channel for GFSK							
Channel	Frequency	Channel	Frequency	Channel	Frequency	Channel	Frequency
0	902.50MHz	13	909.00MHz	26	915.50MHz	39	922.00MHz
1	903.00MHz	14	909.50MHz	27	916.00MHz	40	922.50MHz
2	903.50MHz	15	910.00MHz	28	916.50MHz	41	923.00MHz
3	904.00MHz	16	910.50MHz	29	917.00MHz	42	923.50MHz
4	904.50MHz	17	911.00MHz	30	917.50MHz	43	924.00MHz
5	905.00MHz	18	911.50MHz	31	918.00MHz	44	924.50MHz
6	905.50MHz	19	912.00MHz	32	918.50MHz	45	925.50MHz
7	906.00MHz	20	912.50MHz	33	919.00MHz	46	926.00MHz
8	906.50MHz	21	913.00MHz	34	919.50MHz	47	926.50MHz
9	907.00MHz	22	913.50MHz	35	920.00MHz	48	927.00MHz
10	907.50MHz	23	914.00MHz	36	920.50MHz	49	927.50MHz
11	908.00MHz	24	914.50MHz	37	921.00MHz		
12	908.50MHz	25	915.00MHz	38	921.50MHz		
Remark: Channel 0, 25 & 49 selected for GFSK.							

5.3 Test mode

Transmitting mode:	Keep the EUT in transmitting mode with worst case data rate.
<p>The sample was placed 0.8m above the ground plane of 3m chamber*. Measurements in both horizontal and vertical polarities were performed. During the test, each emission was maximized by: having the EUT continuously working with a fresh battery, investigated all operating modes, rotated about all 3 axis (X, Y & Z) and considered typical configuration to obtain worst position, manipulating interconnecting cables, rotating the turntable, varying antenna height from 1m to 4m in both horizontal and vertical polarizations. The emissions worst-case are shown in Test Results of the following pages.</p>	

5.4 Laboratory Facility

<p>The test facility is recognized, certified, or accredited by the following organizations:</p> <ul style="list-style-type: none"> ● FCC - Registration No.: 817957 Shenzhen Zhongjian Nanfang Testing Co., Ltd. EMC Laboratory has been registered and fully described in a report filed with the (FCC) Federal Communications Commission. The acceptance letter from the FCC is maintained in out files. Registration 817957, February 27, 2012. ● IC - Registration No.: 10106A-1 The 3m Semi-anechoic chamber of Shenzhen Zhongjian Nanfang Testing Co., Ltd. has been Registered by Certification and Engineering Bureau of Industry Canada for radio equipment testing with Registration No.: 10106A-1. ● CNAS - Registration No.: CNAS L6048 Shenzhen Zhongjian Nanfang Testing Co., Ltd. is accredited to ISO/IEC 17025:2005 General Requirements for the Competence of Testing and Calibration laboratories for the competence of testing. The Registration No. is CNAS L6048.
--

5.5 Laboratory Location

<p>Shenzhen Zhongjian Nanfang Testing Co., Ltd. Address: No. B-C, 1/F., Building 2, Laodong No.2 Industrial Park, Xixiang Road, Bao'an District, Shenzhen, Guangdong, China Tel: +86-755-23118282 Fax: +86-755-23116366</p>

5.6 Description of Support Units

N/A

5.7 Test Instruments list

Old calibration test Instruments list

Radiated Emission:						
Item	Test Equipment	Manufacturer	Model No.	Inventory No.	Cal. Date (mm-dd-yy)	Cal. Due date (mm-dd-yy)
1	3m SAC	SAEMC	9(L)*6(W)* 6(H)	CCIS0001	08-23-2014	08-22-2017
2	BiConiLog Antenna	SCHWARZBECK	VULB9163	CCIS0005	03-25-2016	03-25-2017
3	Horn Antenna	SCHWARZBECK	BBHA9120D	CCIS0006	03-25-2016	03-25-2017
4	Pre-amplifier (10kHz-1.3GHz)	HP	8447D	CCIS0003	04-01-2016	03-31-2017
5	Pre-amplifier (1GHz-18GHz)	Compliance Direction Systems Inc.	PAP-1G18	CCIS0011	04-01-2016	03-31-2017
6	Pre-amplifier (18-26GHz)	Rohde & Schwarz	AFS33-18002 650-30-8P-44	GTS218	04-01-2016	03-31-2017
7	Horn Antenna	ETS-LINDGREN	3160	GTS217	04-01-2016	03-31-2017
8	Spectrum analyzer 9k-30GHz	Rohde & Schwarz	FSP30	CCIS0023	03-28-2016	03-28-2017
9	EMI Test Receiver	Rohde & Schwarz	ESRP7	CCIS0167	03-28-2016	03-28-2017
10	Loop antenna	Laplace instrument	RF300	EMC0701	04-01-2016	03-31-2017
11	EMI Test Software	AUDIX	E3	N/A	N/A	N/A

Conducted Emission:						
Item	Test Equipment	Manufacturer	Model No.	Inventory No.	Cal. Date (mm-dd-yy)	Cal. Due date (mm-dd-yy)
1	Shielding Room	ZhongShuo Electron	11.0(L)x4.0(W)x3.0(H)	CCIS0061	08-23-2014	08-22-2017
2	EMI Test Receiver	Rohde & Schwarz	ESCI	CCIS0002	03-24-2016	03-24-2017
3	LISN	CHASE	MN2050D	CCIS0074	03-26-2016	03-26-2017
4	Coaxial Cable	CCIS	N/A	CCIS0086	04-01-2016	03-31-2017
5	EMI Test Software	AUDIX	E3	N/A	N/A	N/A

Latest calibration test Instruments list

Radiated Emission:						
Item	Test Equipment	Manufacturer	Model No.	Inventory No.	Cal. Date (mm-dd-yy)	Cal. Due date (mm-dd-yy)
1	3m SAC	SAEMC	9(L)*6(W)* 6(H)	CCIS0001	08-23-2014	08-22-2017
2	BiConiLog Antenna	SCHWARZBECK	VULB9163	CCIS0005	02-24-2017	02-25-2018
3	Horn Antenna	SCHWARZBECK	BBHA9120D	CCIS0006	02-24-2017	02-25-2018
4	Pre-amplifier (10kHz-1.3GHz)	HP	8447D	CCIS0003	02-24-2017	02-25-2018
5	Pre-amplifier (1GHz-18GHz)	Compliance Direction Systems Inc.	PAP-1G18	CCIS0011	02-24-2017	02-25-2018
6	Pre-amplifier (18-26GHz)	Rohde & Schwarz	AFS33-18002 650-30-8P-44	GTS218	02-24-2017	02-25-2018
7	Horn Antenna	ETS-LINDGREN	3160	GTS217	02-24-2017	02-25-2018
8	Spectrum analyzer 9k-30GHz	Rohde & Schwarz	FSP30	CCIS0023	02-24-2017	02-25-2018
9	EMI Test Receiver	Rohde & Schwarz	ESRP7	CCIS0167	02-24-2017	02-25-2018
10	Loop antenna	Laplace instrument	RF300	EMC0701	02-24-2017	02-25-2018
11	EMI Test Software	AUDIX	E3	N/A	N/A	N/A

Conducted Emission:						
Item	Test Equipment	Manufacturer	Model No.	Inventory No.	Cal. Date (mm-dd-yy)	Cal. Due date (mm-dd-yy)
1	Shielding Room	ZhongShuo Electron	11.0(L)x4.0(W)x3.0(H)	CCIS0061	08-23-2014	08-22-2017
2	EMI Test Receiver	Rohde & Schwarz	ESCI	CCIS0002	02-24-2017	02-25-2018
3	LISN	CHASE	MN2050D	CCIS0074	02-24-2017	02-25-2018
4	Coaxial Cable	CCIS	N/A	CCIS0086	02-24-2017	02-25-2018
5	EMI Test Software	AUDIX	E3	N/A	N/A	N/A

6 Test results and Measurement Data

6.1 Antenna requirement

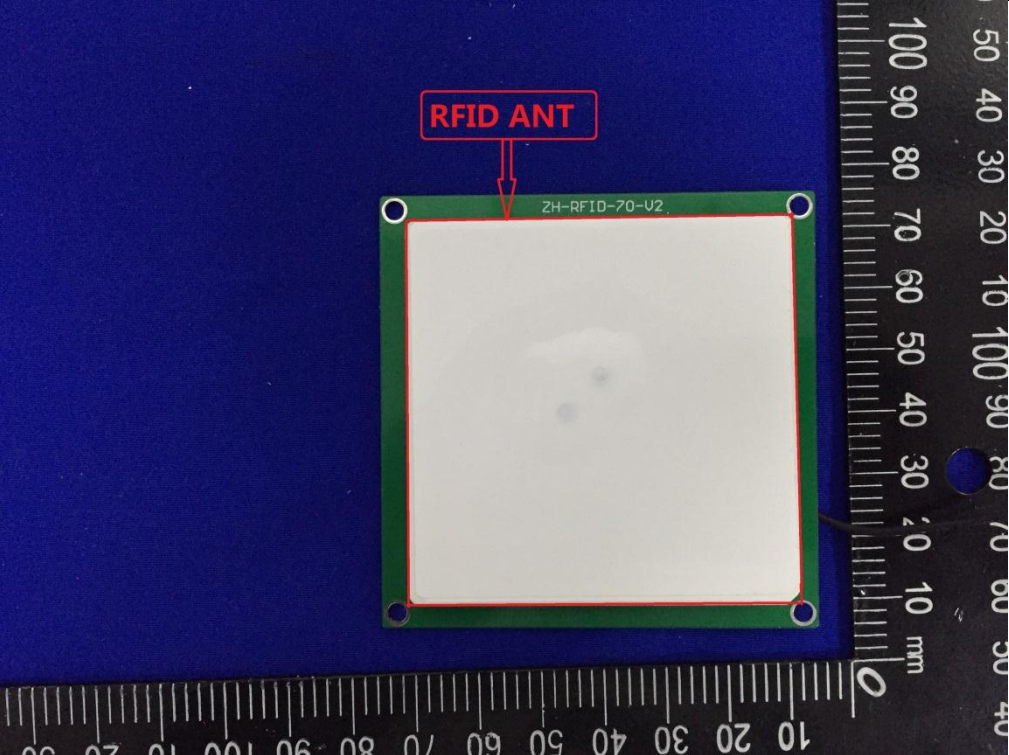
Standard requirement:	FCC Part 15 C Section 15.203 /247(c)
<p><i>15.203 requirement:</i> <i>An intentional radiator shall be designed to ensure that no antenna other than that furnished by the responsible party shall be used with the device. The use of a permanently attached antenna or of an antenna that uses a unique coupling to the intentional radiator, the manufacturer may design the unit so that a broken antenna can be replaced by the user, but the use of a standard antenna jack or electrical connector is prohibited.</i></p> <p><i>15.247(B) (4) requirement:</i> <i>(4) The conducted output power limit specified in paragraph (b) of this section is based on the use of antennas with directional gains that do not exceed 6 dBi. Except as shown in paragraph (c) of this The conducted output power limit specified in paragraph (b) of this section is based on the use The conducted output power limit specified in paragraph (b) of this section is based on the use (2), and (b)(3) of this section, as appropriate, by the amount in dB that the directional gain of the antenna exceeds 6 dBi.</i></p>	
E.U.T Antenna:	
<p><i>The antenna is an integral antenna which permanently attached, and the best case gain of the antenna is 3 dBi.</i></p>	
 <p>The photograph shows a square RFID antenna (model ZH-RFID-70-U2) mounted on a blue printed circuit board (PCB). The antenna is a light-colored square with a green border. A red box with the text 'RFID ANT' and a red arrow points to the antenna. A black ruler is placed to the right and bottom of the antenna for scale, showing measurements in millimeters. The ruler indicates the antenna is approximately 30 mm wide and 30 mm high.</p>	

6.2 Conducted Emissions

Test Requirement:	FCC Part 15 C Section 15.207														
Test Method:	ANSI C63.4:2014														
Test Frequency Range:	150 kHz to 30 MHz														
Class / Severity:	Class B														
Receiver setup:	RBW=9 kHz, VBW=30 kHz, Sweep time=auto														
Limit:	<table border="1"> <thead> <tr> <th rowspan="2">Frequency range (MHz)</th> <th colspan="2">Limit (dBuV)</th> </tr> <tr> <th>Quasi-peak</th> <th>Average</th> </tr> </thead> <tbody> <tr> <td>0.15-0.5</td> <td>66 to 56*</td> <td>56 to 46*</td> </tr> <tr> <td>0.5-5</td> <td>56</td> <td>46</td> </tr> <tr> <td>5-30</td> <td>60</td> <td>50</td> </tr> </tbody> </table> <p>* Decreases with the logarithm of the frequency.</p>	Frequency range (MHz)	Limit (dBuV)		Quasi-peak	Average	0.15-0.5	66 to 56*	56 to 46*	0.5-5	56	46	5-30	60	50
Frequency range (MHz)	Limit (dBuV)														
	Quasi-peak	Average													
0.15-0.5	66 to 56*	56 to 46*													
0.5-5	56	46													
5-30	60	50													
Test setup:	<p><i>Remark:</i> E.U.T: Equipment Under Test LISN: Line Impedance Stabilization Network Test table height=0.8m</p>														
Test procedure:	<ol style="list-style-type: none"> 1. The E.U.T and simulators are connected to the main power through a line impedance stabilization network (L.I.S.N.). This provides a 50ohm/50uH coupling impedance for the measuring equipment. 2. The peripheral devices are also connected to the main power through a LISN that provides a 50ohm/50uH coupling impedance with 50ohm termination. (Please refer to the block diagram of the test setup and photographs). 3. Both sides of A.C. line are checked for maximum conducted interference. In order to find the maximum emission, the relative positions of equipment and all of the interface cables must be changed according to ANSI C63.4: 2003 on conducted measurement. 														
Test Instruments:	Refer to section 5.7 for details														
Test mode:	Continuous transmitting mode														
Test results:	Pass														

Measurement Data

Line:

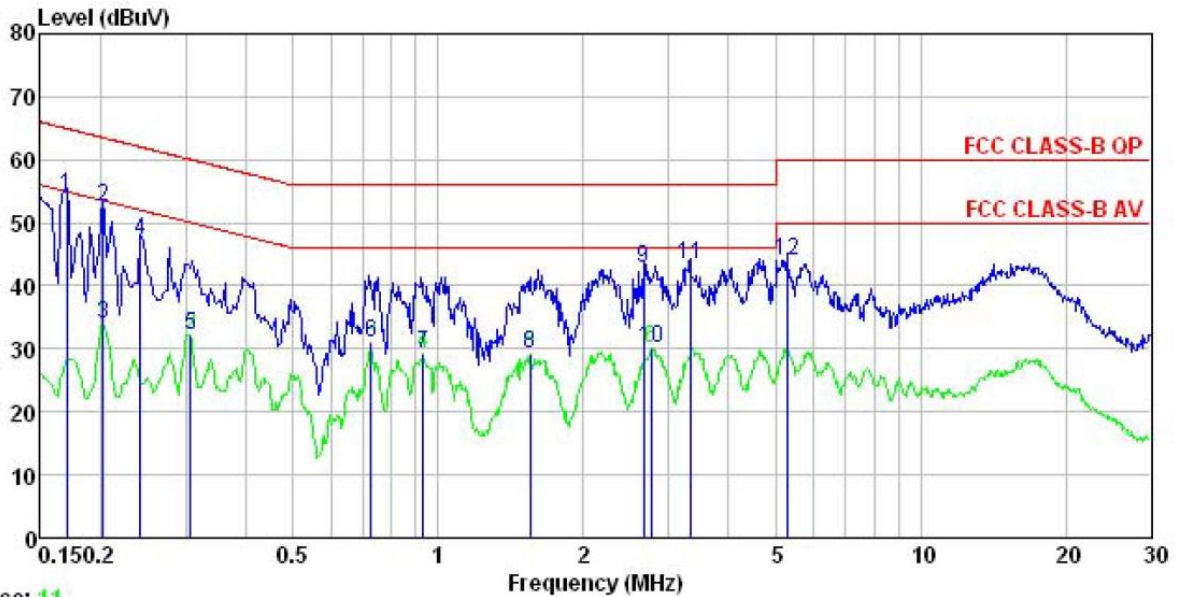

Trace: 11

Site : CCIS Shielding Room
 Condition : FCC CLASS-B QP LISN LINE
 EUT : ORCA-50 Handheld Data Terminal
 Model : ORCA-50
 Test Mode : RFID Mode
 Power Rating : AC 120V/60Hz
 Environment : Temp: 23 °C Humi:56% Atmos:101KPa
 Test Engineer: Carey
 Remark :

	Read	LISN	Cable	Limit	Over	
Freq	Level	Factor	Loss	Level	Line	Limit Remark
MHz	dBuV	dB	dB	dBuV	dBuV	dB
1	0.170	43.55	0.14	10.77	54.46	64.94 -10.48 QP
2	0.202	41.66	0.15	10.76	52.57	63.54 -10.97 QP
3	0.202	23.09	0.15	10.76	34.00	53.54 -19.54 Average
4	0.242	36.36	0.15	10.75	47.26	62.04 -14.78 QP
5	0.307	21.39	0.17	10.74	32.30	50.06 -17.76 Average
6	0.727	19.85	0.31	10.78	30.94	46.00 -15.06 Average
7	0.933	18.03	0.27	10.85	29.15	46.00 -16.85 Average
8	1.552	18.13	0.30	10.93	29.36	46.00 -16.64 Average
9	2.664	31.66	0.33	10.93	42.92	56.00 -13.08 QP
10	2.765	18.93	0.33	10.93	30.19	46.00 -15.81 Average
11	3.328	32.17	0.33	10.91	43.41	56.00 -12.59 QP
12	5.277	32.92	0.35	10.84	44.11	60.00 -15.89 QP

Neutral:

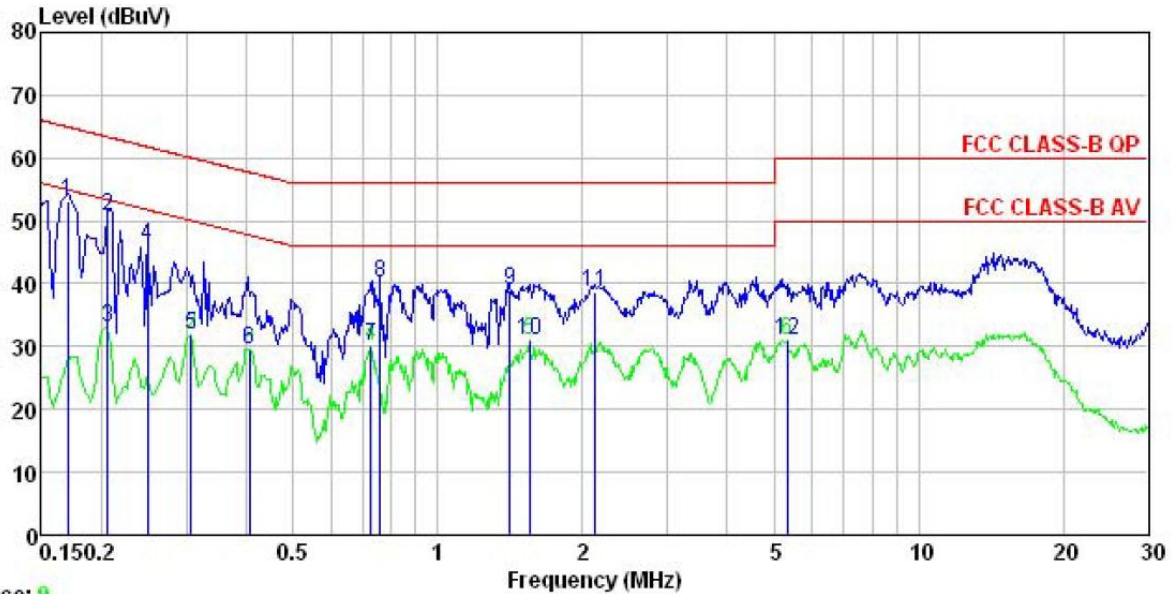

Trace: 9

Site : CCIS Shielding Room
 Condition : FCC CLASS-B QP LISN NEUTRAL
 EUT : ORCA-50 Handheld Data Terminal
 Model : ORCA-50
 Test Mode : RFID Mode
 Power Rating : AC 120V/60Hz
 Environment : Temp: 23 °C Humi:56% Atmos:101KPa
 Test Engineer: Carey
 Remark :

	Freq	Read Level	LISN Factor	Cable Loss	Level	Limit Line	Over Limit	Remark
	MHz	dBuV	dB	dB	dBuV	dBuV	dB	
1	0.170	42.35	0.13	10.77	53.25	64.94	-11.69	QP
2	0.206	39.78	0.15	10.76	50.69	63.36	-12.67	QP
3	0.206	22.13	0.15	10.76	33.04	53.36	-20.32	Average
4	0.249	35.06	0.17	10.75	45.98	61.78	-15.80	QP
5	0.307	20.96	0.19	10.74	31.89	50.06	-18.17	Average
6	0.406	18.60	0.23	10.72	29.55	47.73	-18.18	Average
7	0.727	19.04	0.32	10.78	30.14	46.00	-15.86	Average
8	0.759	29.14	0.31	10.80	40.25	56.00	-15.75	QP
9	1.411	27.78	0.26	10.91	38.95	56.00	-17.05	QP
10	1.552	19.72	0.26	10.93	30.91	46.00	-15.09	Average
11	2.121	27.50	0.27	10.95	38.72	56.00	-17.28	QP
12	5.333	19.91	0.33	10.84	31.08	50.00	-18.92	Average

Notes:

1. An initial pre-scan was performed on the line and neutral lines with peak detector.
2. Quasi-Peak and Average measurement were performed at the frequencies with maximized peak emission.
3. Final Level =Receiver Read level + LISN Factor + Cable Loss

6.3 Conducted Output Power

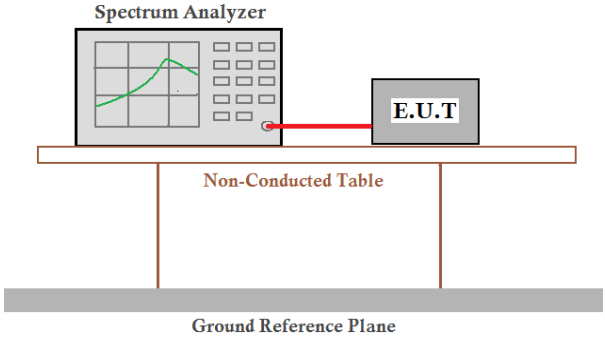
Test Requirement:	FCC Part 15 C Section 15.247 (b)(2)
Test Method:	ANSI C63.10:2013 and DA00-705
Receiver setup:	RBW=300KHz, VBW=1MHz, Detector=Peak (If 20dB BW ≤300KHz)
Limit:	1W(30 dBm)
Test setup:	
Test Instruments:	Refer to section 5.7 for details
Test mode:	Non-hopping mode
Test results:	Pass

Measurement Data

Test channel	Peak Output Power (dBm)	Limit (dBm)	Result
Lowest	29.99	30.00	Pass
Middle	29.98	30.00	Pass
Highest	29.98	30.00	Pass

Test plot as follows:

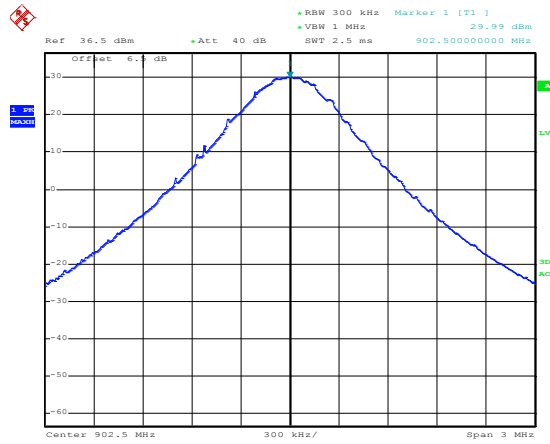

Date: 28.MAR.2017 22:25:40

Lowest channel

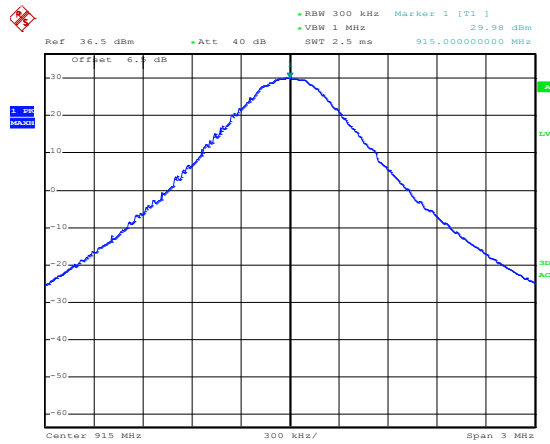

Date: 28.MAR.2017 22:29:59

Middle channel

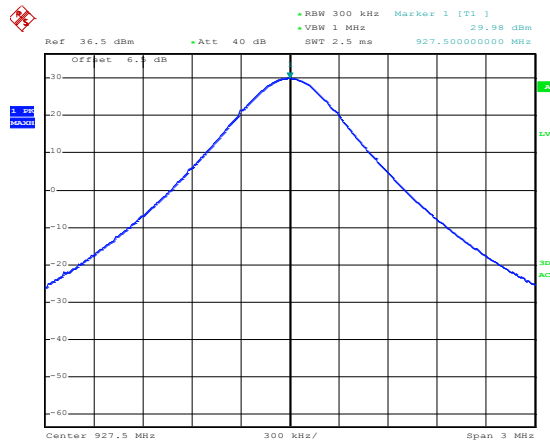

Date: 25.MAY.2017 16:04:44

Highest channel

6.4 20dB Occupy Bandwidth

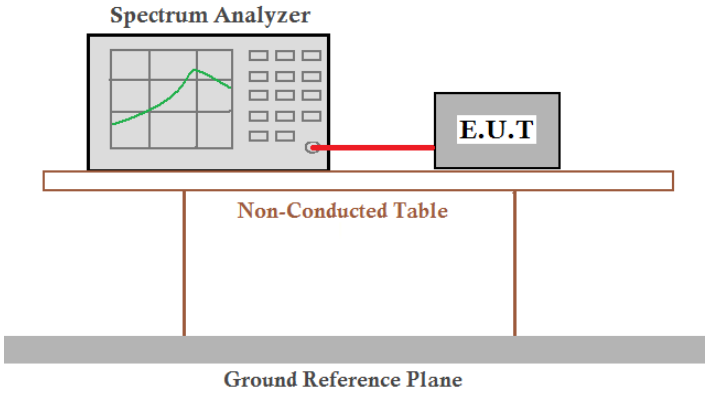
Test Requirement:	FCC Part 15 C Section 15.247 (a)(1)
Test Method:	ANSI C63.10:2013 and DA00-705
Receiver setup:	RBW=30 kHz, VBW=100 kHz, detector=Peak
Limit:	500 kHz
Test setup:	 <p>The diagram illustrates the test setup. A Spectrum Analyzer is connected to an E.U.T. (Equipment Under Test) via a red cable. Both are placed on a Non-Conducted Table, which sits on a Ground Reference Plane.</p>
Test Instruments:	Refer to section 5.7 for details
Test mode:	Non-hopping mode
Test results:	Pass

Measurement Data

Test channel	20dB Occupy Bandwidth (kHz)	Limit (kHz)
Lowest	134	500
Middle	140	500
Highest	199	500

Test plot as follows:

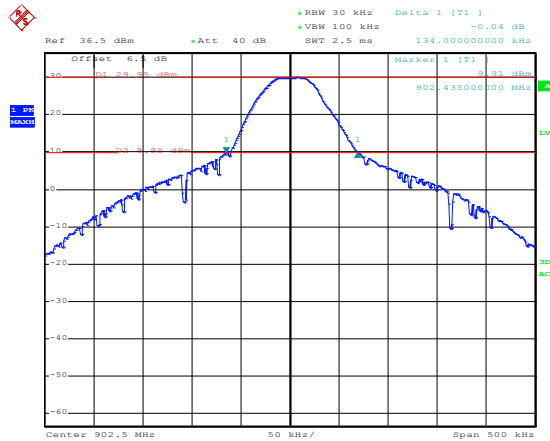

Date: 28.MAR.2017 22:41:42

Lowest channel

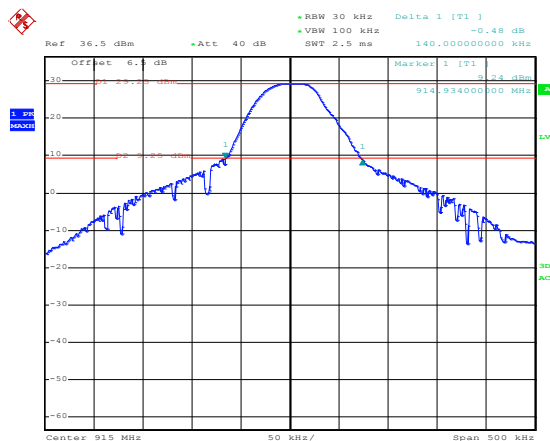

Date: 28.MAR.2017 22:38:25

Middle channel

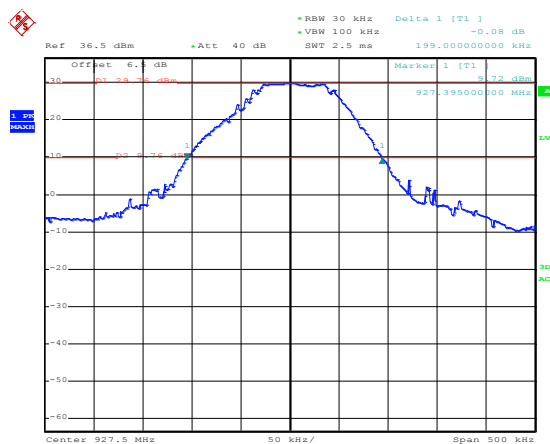

Date: 28.MAR.2017 22:35:16

Highest channel

6.5 Carrier Frequencies Separation

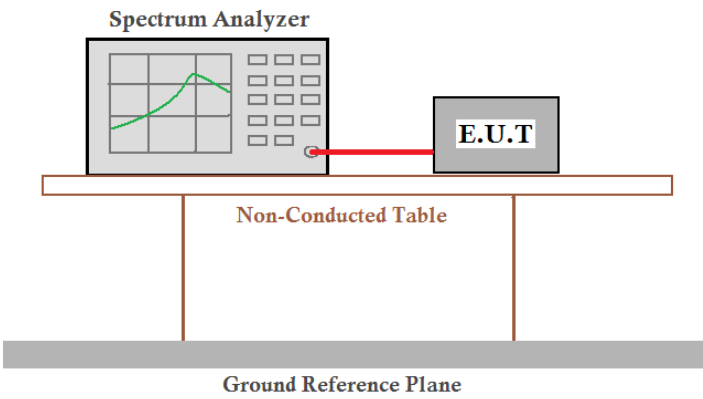
Test Requirement:	FCC Part 15 C Section 15.247 (a)(1)
Test Method:	ANSI C63.10:2013 and DA00-705
Receiver setup:	RBW=100 kHz, VBW=300 kHz, detector=Peak
Limit:	Frequency hopping systems shall have hopping channel carrier frequencies separated by a minimum of 25 kHz or the 20 dB bandwidth of the hopping channel, whichever is greater.
Test setup:	 <p>The diagram illustrates the test setup. A Spectrum Analyzer is connected via a red cable to an E.U.T. (Equipment Under Test). Both are placed on a Non-Conducted Table. Below the table is a Ground Reference Plane.</p>
Test Instruments:	Refer to section 5.7 for details
Test mode:	Hopping mode
Test results:	Pass

Measurement Data

Test channel	Carrier Frequencies Separation (kHz)	Limit (kHz)
Lowest	500	174
Middle	500	181
Highest	500	133

Test plot as follows:

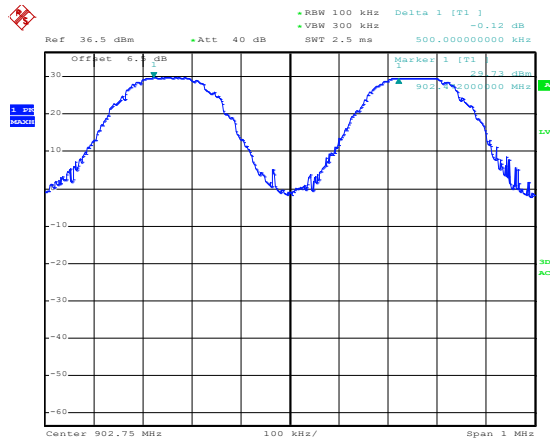

Date: 28.MAR.2017 22:52:42

Lowest channel

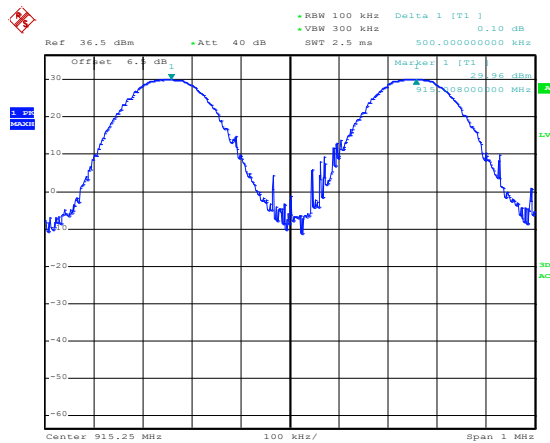

Date: 28.MAR.2017 22:51:07

Middle channel

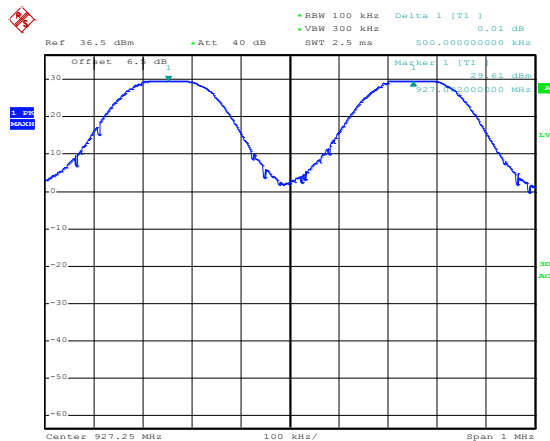

Date: 28.MAR.2017 22:48:57

Highest channel

6.6 Hopping Channel Number

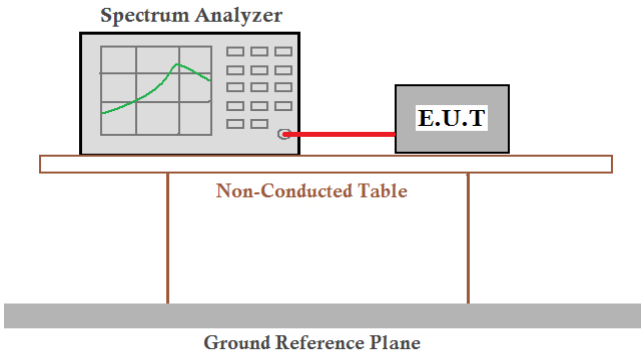
Test Requirement:	FCC Part 15 C Section 15.247 (a)(1)
Test Method:	ANSI C63.10:2013 and DA00-705
Receiver setup:	RBW=100 kHz, VBW=300 kHz, Frequency range=902MHz-928MHz, Detector=Peak
Limit:	25 channels \leq Hopping number < 50 channels (If 250 kHz \leq 20dB bandwidth \leq 500kHz) Hopping number \geq 50 channels (If 20 dB bandwidth < 250 kHz)
Test setup:	 <p>The diagram illustrates the test setup. A Spectrum Analyzer is connected via a red cable to an E.U.T. (Equipment Under Test). Both are placed on a Non-Conducted Table. Below the table is a Ground Reference Plane.</p>
Test Instruments:	Refer to section 5.7 for details
Test mode:	Hopping mode
Test results:	Pass

Measurement Data:

Hopping channel numbers	Limit	Result
50	50	Pass

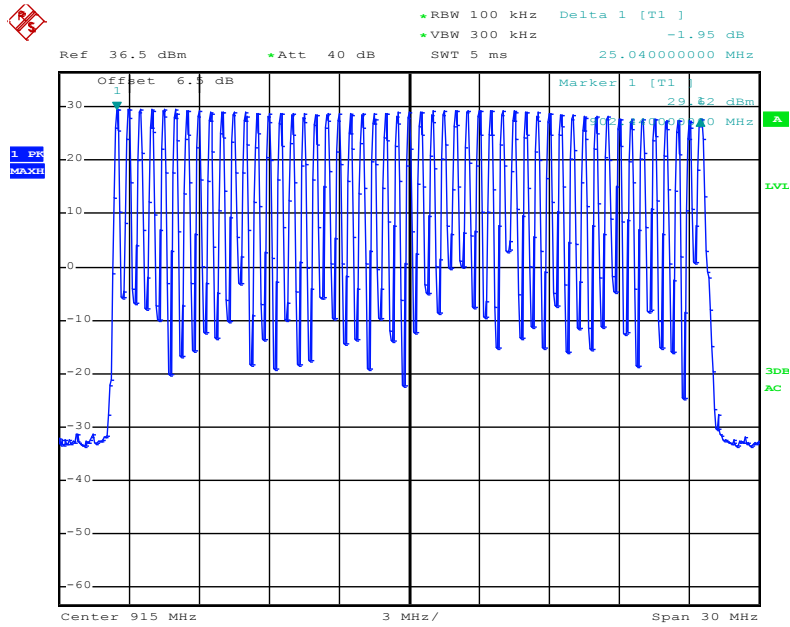

Date: 28.MAR.2017 22:59:48

6.7 Dwell Time

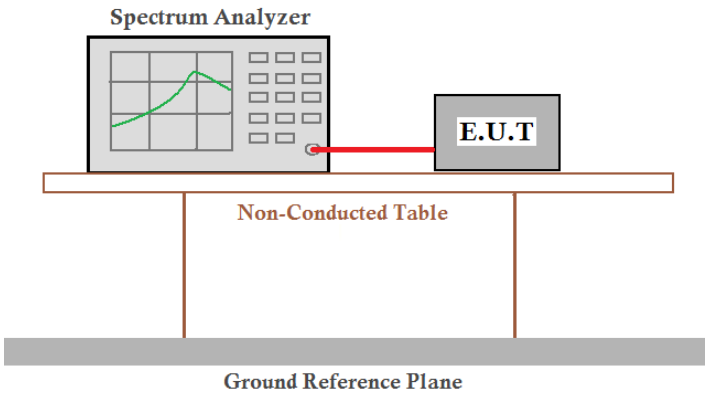
Test Requirement:	FCC Part 15 C Section 15.247 (a)(1)
Test Method:	ANSI C63.10:2013 and KDB DA00-705
Receiver setup:	RBW=1 MHz, VBW=1 MHz, Span=0 Hz, Detector=Peak
Limit:	0.4 Second (If 20 dB bandwidth < 250 kHz, the average time of occupancy on any frequency shall not be greater than 0.4 seconds within a 20 second period; if 250 kHz ≤ 20 dB bandwidth ≤ 500kHz, the average time of occupancy on any frequency shall not be greater than 0.4 seconds within a 10 second period.)
Test setup:	 <p>The diagram shows a Spectrum Analyzer and an E.U.T. (Equipment Under Test) connected by a red cable. They are placed on a table labeled 'Non-Conducted Table', which is supported by a 'Ground Reference Plane'.</p>
Test Instruments:	Refer to section 5.7 for details
Test mode:	Hopping mode
Test results:	Pass

Measurement Data

Dwell time per hop (Second)	Hopping numbers	Dwell time in one period (Second)	Limit (Second)	Result
0.01612	13	0.20956	0.4	Pass

Remark:

The test period: T= 20s

Test plot as follows:

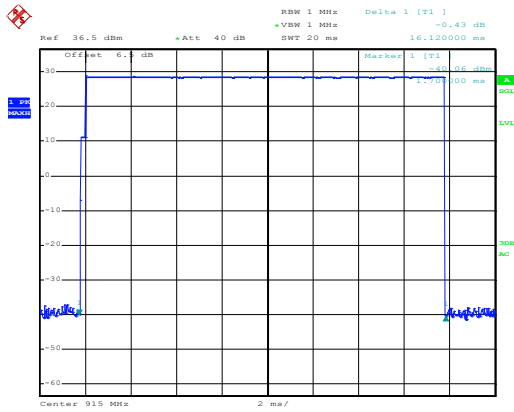

Date: 28.MAR.2017 23:01:39

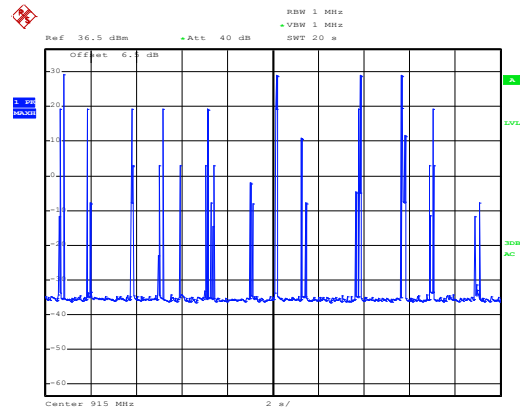

Date: 28.MAR.2017 23:04:23

6.8 Pseudorandom Frequency Hopping Sequence

Test Requirement:	FCC Part 15 C Section 15.247 (a)(1) requirement:
<p>For frequency hopping systems operating in the 902-928 MHz band: if the 20 dB bandwidth of the hopping channel is less than 250 kHz, the system shall use at least 50 hopping frequencies and the average time of occupancy on any frequency shall not be greater than 0.4 seconds within a 20 second period; if the 20 dB bandwidth of the hopping channel is 250 kHz or greater, the system shall use at least 25 hopping frequencies and the average time of occupancy on any frequency shall not be greater than 0.4 seconds within a 10 second period. The maximum allowed 20 dB bandwidth of the hopping channel is 500 kHz</p>	
EUT Pseudorandom Frequency Hopping Sequence	
<p>The pseudorandom sequence may be generated in a nine-stage shift register whose 5th and 9th stage outputs are added in a modulo-two addition stage. And the result is fed back to the input of the first stage. The sequence begins with the first ONE of 9 consecutive ONES; i.e. the shift register is initialized with nine ones.</p> <ul style="list-style-type: none"> • Number of shift register stages: 9 • Length of pseudo-random sequence: $2^9 - 1 = 511$ bits • Longest sequence of zeros: 8 (non-inverted signal) <div data-bbox="256 801 1294 947" style="text-align: center;"> </div> <p style="text-align: center;"><i>Linear Feedback Shift Register for Generation of the PRBS sequence</i></p> <p>An example of Pseudorandom Frequency Hopping Sequence as follow:</p> <div data-bbox="256 1048 1241 1193" style="text-align: center;"> </div> <p>Each frequency used equally on the average by each transmitter. The system receivers have input bandwidths that match the hopping channel bandwidths of their corresponding transmitters and shift frequencies in synchronization with the transmitted signals.</p>	

6.9 Band Edge

6.9.1 Conducted Emission Method

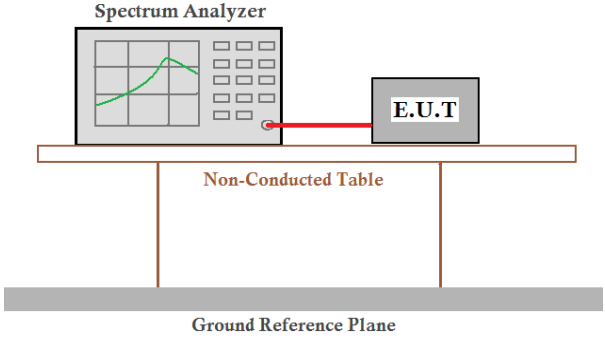
Test Requirement:	FCC Part 15 C Section 15.247 (d)
Test Method:	ANSI C63.10:2013 and DA00-705
Receiver setup:	RBW=100 kHz, VBW=300 kHz, Detector=Peak
Limit:	In any 100 kHz bandwidth outside the frequency band in which the spread spectrum intentional radiator is operating, the radio frequency power that is produced by the intentional radiator shall be at least 20 dB below that in the 100 kHz bandwidth within the band that contains the highest level of the desired power, based on either an RF conducted or a radiated measurement.
Test setup:	 <p>The diagram illustrates the test setup. A Spectrum Analyzer is connected to an E.U.T. (Equipment Under Test) via a red cable. Both are placed on a Non-Conducted Table, which is supported by a Ground Reference Plane.</p>
Test Instruments:	Refer to section 5.7 for details
Test mode:	Non-hopping mode and hopping mode
Test results:	Pass

Test plot as follows:

Lowest Channel

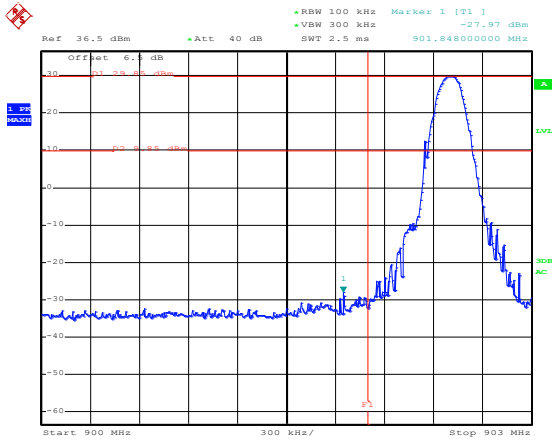

Date: 28.MAR.2017 22:44:44

Non-hopping

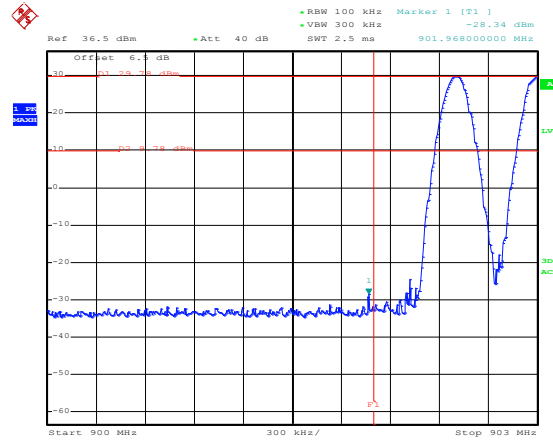

Date: 28.MAR.2017 22:44:18

Hopping

Highest Channel

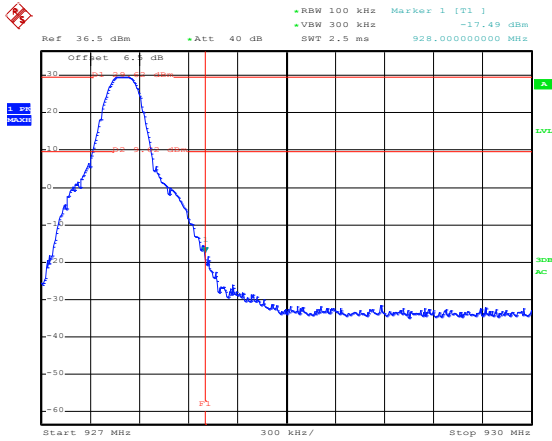

Date: 28.MAR.2017 22:46:13

Non-hopping

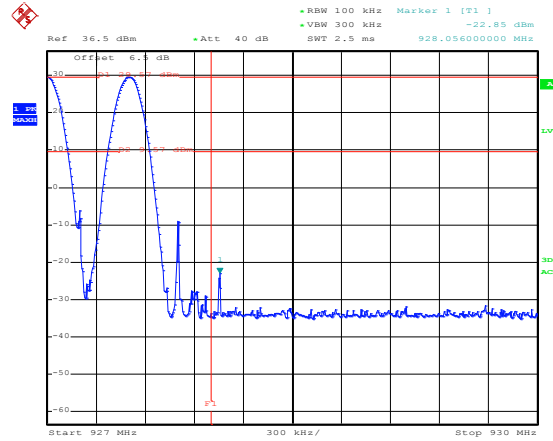

Date: 28.MAR.2017 22:47:12

Hopping

6.10 Spurious Emission

6.10.1 Conducted Emission Method

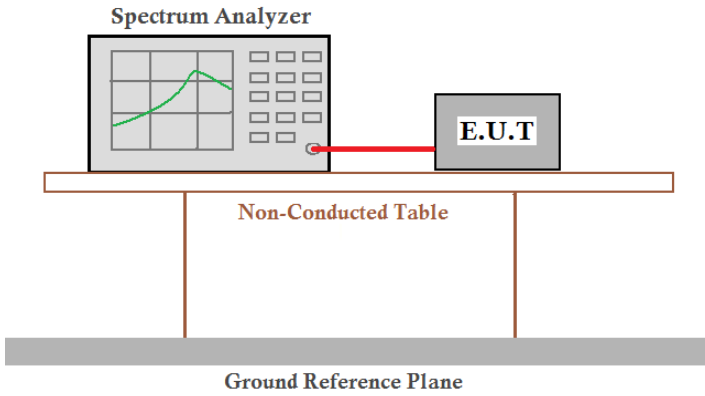
Test Requirement:	FCC Part 15 C Section 15.247 (d)
Test Method:	ANSI C63.10:2013and DA00-705
Limit:	In any 100 kHz bandwidth outside the frequency band in which the spread spectrum intentional radiator is operating, the radio frequency power that is produced by the intentional radiator shall be at least 20 dB below that in the 100 kHz bandwidth within the band that contains the highest level of the desired power, based on either an RF conducted or a radiated measurement.
Test setup:	 <p>The diagram illustrates the test setup. A Spectrum Analyzer is connected to an E.U.T. (Equipment Under Test) via a red cable. Both are placed on a Non-Conducted Table, which is supported by two legs. Below the table is a Ground Reference Plane.</p>
Test Instruments:	Refer to section 5.7 for details
Test mode:	Non-hopping mode
Test results:	Pass

Lowest channel

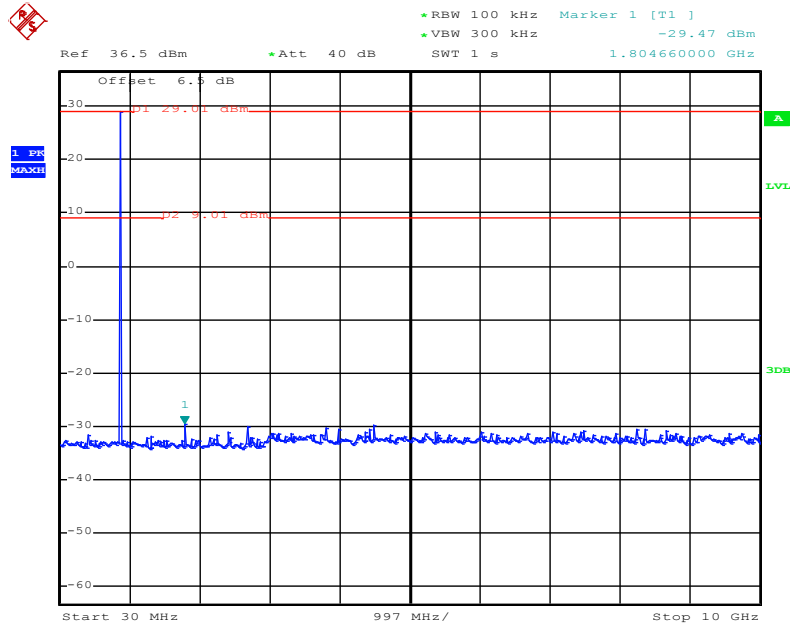

Date: 26.MAR.2017 05:52:43

30MHz~10GHz

Middle channel

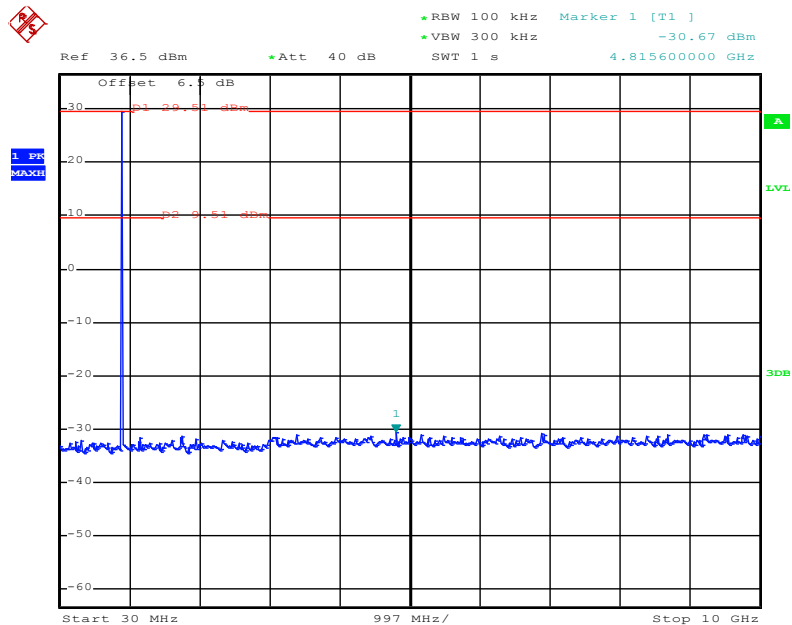

Date: 26.MAR.2017 05:54:15

30MHz~10GHz

Highest channel

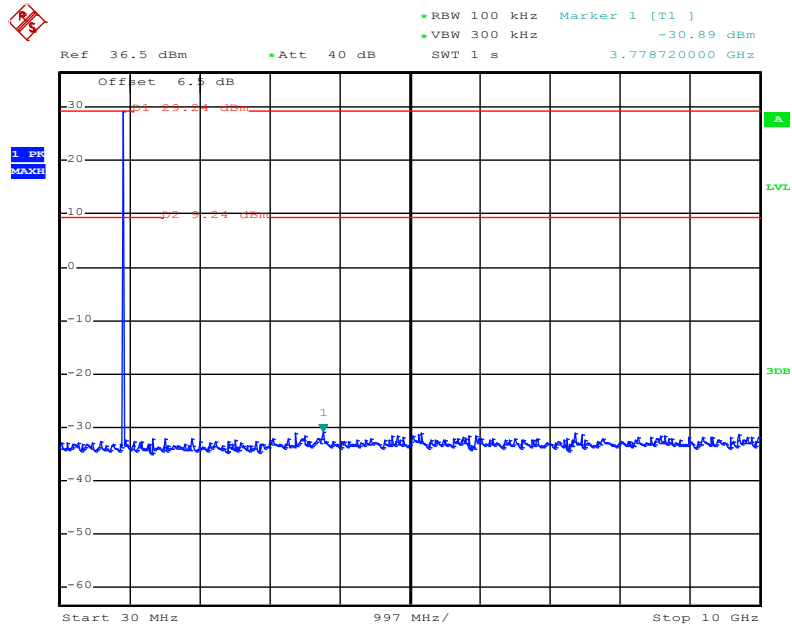

Date: 26.MAR.2017 05:55:02

30MHz~10GHz

6.10.2 Radiated Emission Method

Test Requirement:	FCC Part 15 C Section 15.205/15.209 /15.247(d)				
Test Method:	ANSI C63.10:2013				
Test Frequency Range:	9 kHz to 10 GHz				
Test site:	Measurement Distance: 3m				
Receiver setup:	Frequency	Detector	RBW	VBW	Remark
	30MHz-1GHz	Quasi-peak	120kHz	300kHz	Quasi-peak Value
	Above 1GHz	Peak	1MHz	3MHz	Peak Value
		Peak	1MHz	10Hz	Average Value
Limit:	Frequency	Limit (dBuV/m @3m)		Remark	
	30MHz-88MHz	40.0		Quasi-peak Value	
	88MHz-216MHz	43.5		Quasi-peak Value	
	216MHz-960MHz	46.0		Quasi-peak Value	
	960MHz-1GHz	54.0		Quasi-peak Value	
	Above 1GHz	54.0		Average Value	
74.0		Peak Value			
Test setup:	Below 1GHz				
Test setup:	Above 1GHz				

Test Procedure:	<ol style="list-style-type: none"> 1. The EUT was placed on the top of a rotating table 0.8 meters above the ground at a 3 meter camber. The table was rotated 360 degrees to determine the position of the highest radiation. 2. The EUT was set 3 meters away from the interference-receiving antenna, which was mounted on the top of a variable-height antenna tower. 3. The antenna height is varied from one meter to four meters above the ground to determine the maximum value of the field strength. Both horizontal and vertical polarizations of the antenna are set to make the measurement. 4. For each suspected emission, the EUT was arranged to its worst case and then the antenna was tuned to heights from 1 meter to 4 meters and the rota table was turned from 0 degrees to 360 degrees to find the maximum reading. 5. The test-receiver system was set to Peak Detect Function and Specified Bandwidth with Maximum Hold Mode. 6. If the emission level of the EUT in peak mode was 10dB lower than the limit specified, then testing could be stopped and the peak values of the EUT would be reported. Otherwise the emissions that did not have 10dB margin would be re-tested one by one using peak, quasi-peak or average method as specified and then reported in a data sheet.
Test Instruments:	Refer to section 5.7 for details
Test mode:	Non-hopping mode
Test results:	Pass

Remark:

1. Pre-scan all kind of the place mode (X-axis, Y-axis, Z-axis), and found the Y-axis is the worst case.
2. 9 kHz to 30 MHz is noise floor, so only shows the data of above 30MHz in this report.
3. Low, mid and high 3 channels all have been tested for 30MHz to 1GHz, only report worst case.

Measurement data:

Below 1GHz

Vertical:

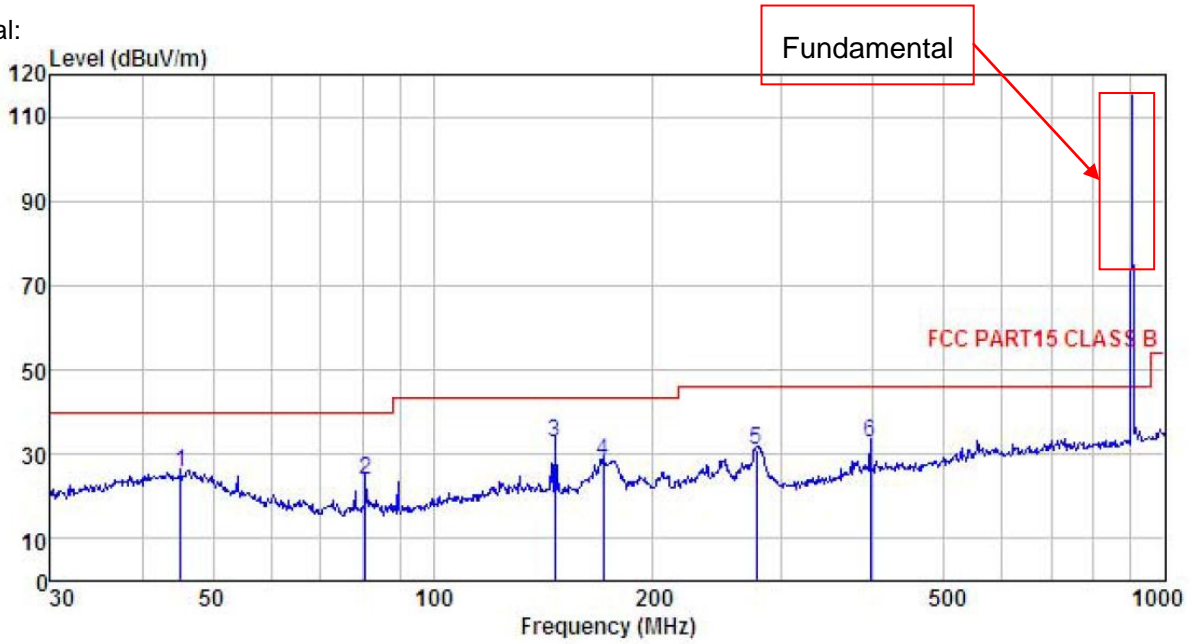

Site : 3m chamber
 Condition : FCC PART15 CLASS B 3m VULB9163(30M3G) VERTICAL
 EUT : ORCA-50 Handheld Data Terminal)
 Model : ORCA-50
 Test mode : RFID Mode
 Power Rating : AC120V/60Hz
 Environment : Temp:25.5°C Humi:55%
 Test Engineer: Carey
 REMARK :

	ReadAntenna	Cable	Preamp		Limit	Over		
Freq	Level	Factor	Loss	Factor	Level	Line	Limit	Remark
MHz	dBuV	dB/m	dB	dB	dBuV/m	dBuV/m	dB	
1	45.217	6.99	17.36	1.29	0.00	25.64	40.00	-14.36 QP
2	80.927	15.69	6.65	1.69	0.00	24.03	40.00	-15.97 QP
3	146.888	19.50	10.99	2.47	0.00	32.96	43.50	-10.54 QP
4	170.793	16.06	9.75	2.66	0.00	28.47	43.50	-15.03 QP
5	277.094	15.95	12.18	2.88	0.00	31.01	46.00	-14.99 QP
6	396.242	13.94	15.78	3.08	0.00	32.80	46.00	-13.20 QP

Horizontal:

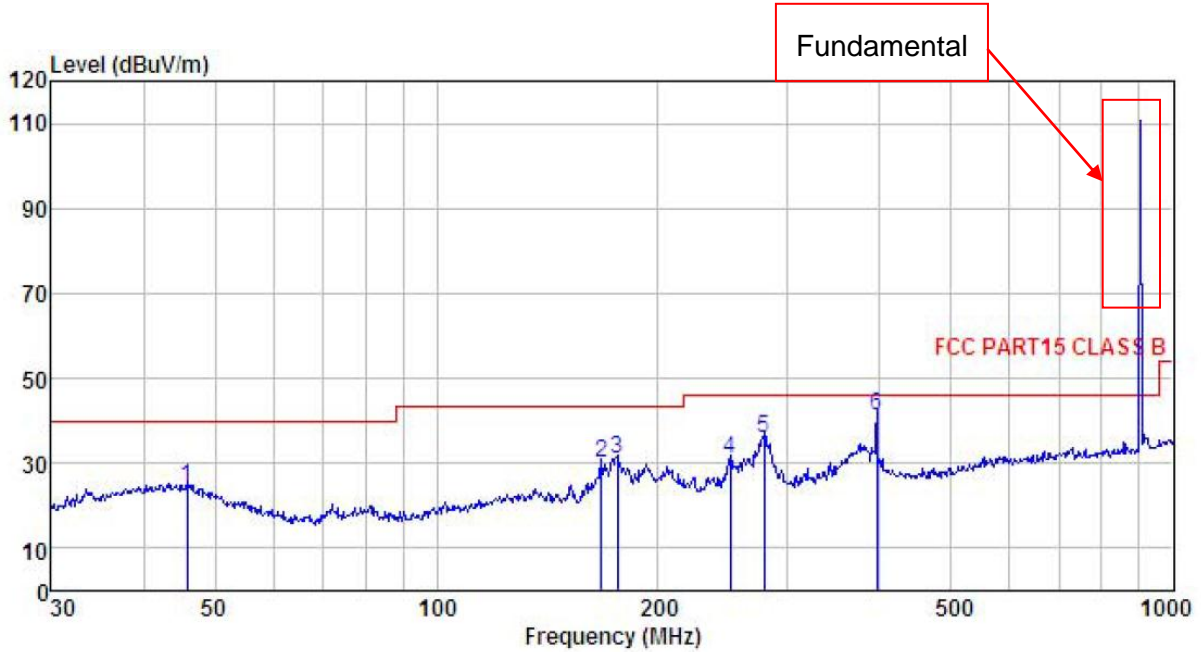

Site : 3m chamber
 Condition : FCC PART15 CLASS B 3m VULB9163(30M3G) HORIZONTAL
 EUT : ORCA-50 Handheld Data Terminal)
 Model : ORCA-50
 Test mode : RFID Mode
 Power Rating : AC120V/60Hz
 Environment : Temp:25.5°C Humi:55%
 Test Engineer: Carey
 REMARK :

	ReadAntenna	Cable Preamp	Limit	Over				
Freq	Level Factor	Loss Factor	Level	Line	Limit	Remark		
-----MHz	-----dBuV	-----dB/m	-----dB	-----dB	-----dBuV/m	-----dBuV/m	-----dB	-----
1	45.855	5.94	17.24	1.29	0.00	24.47	40.00	-15.53 QP
2	167.237	17.55	9.83	2.64	0.00	30.02	43.50	-13.48 QP
3	176.269	18.88	9.40	2.70	0.00	30.98	43.50	-12.52 QP
4	250.301	16.21	11.88	2.81	0.00	30.90	46.00	-15.10 QP
5	278.067	20.95	12.19	2.88	0.00	36.02	46.00	-9.98 QP
6	396.242	22.50	15.78	3.08	0.00	41.36	46.00	-4.64 QP

Above 1GHz:

Test channel:			Lowest		Level:		Peak	
Frequency (MHz)	Read Level (dBuV)	Antenna Factor (dB/m)	Cable Loss (dB)	Preamp Factor (dB)	Level (dBuV/m)	Limit Line (dBuV/m)	Over Limit (dB)	Polarization
1805.00	79.87	23.10	4.12	41.21	65.88	74.00	-8.12	Vertical
1805.00	75.26	23.10	4.12	41.21	61.27	74.00	-12.73	Horizontal

Test channel:			Lowest		Level:		Average	
Frequency (MHz)	Read Level (dBuV)	Antenna Factor (dB/m)	Cable Loss (dB)	Preamp Factor (dB)	Level (dBuV/m)	Limit Line (dBuV/m)	Over Limit (dB)	Polarization
1805.00	61.63	23.10	4.12	41.21	47.64	54.00	-6.36	Vertical
1805.00	61.35	23.10	4.12	41.21	47.36	54.00	-6.64	Horizontal

Test channel:			Middle		Level:		Peak	
Frequency (MHz)	Read Level (dBuV)	Antenna Factor (dB/m)	Cable Loss (dB)	Preamp Factor (dB)	Level (dBuV/m)	Limit Line (dBuV/m)	Over Limit (dB)	Polarization
1830.00	74.16	23.17	4.15	41.27	60.21	74.00	-13.79	Vertical
1830.00	71.58	23.17	4.15	41.27	57.63	74.00	-16.37	Horizontal

Test channel:			Middle		Level:		Average	
Frequency (MHz)	Read Level (dBuV)	Antenna Factor (dB/m)	Cable Loss (dB)	Preamp Factor (dB)	Level (dBuV/m)	Limit Line (dBuV/m)	Over Limit (dB)	Polarization
1830.00	60.66	23.17	4.15	41.27	46.71	54.00	-7.29	Vertical
1830.00	59.68	23.17	4.15	41.27	45.73	54.00	-8.27	Horizontal

Test channel:			Highest		Level:		Peak	
Frequency (MHz)	Read Level (dBuV)	Antenna Factor (dB/m)	Cable Loss (dB)	Preamp Factor (dB)	Level (dBuV/m)	Limit Line (dBuV/m)	Over Limit (dB)	Polarization
1855.00	74.06	23.22	4.17	41.32	60.13	74.00	-13.87	Vertical
1855.00	72.01	23.22	4.17	41.32	58.08	74.00	-15.92	Horizontal

Test channel:			Highest		Level:		Average	
Frequency (MHz)	Read Level (dBuV)	Antenna Factor (dB/m)	Cable Loss (dB)	Preamp Factor (dB)	Level (dBuV/m)	Limit Line (dBuV/m)	Over Limit (dB)	Polarization
1855.00	61.10	23.22	4.17	41.32	47.17	54.00	-6.83	Vertical
1855.00	60.58	23.22	4.17	41.32	46.65	54.00	-7.35	Horizontal

Remark:

1. *Final Level = Receiver Read level + Antenna Factor + Cable Loss – Pre-amplifier Factor*
2. *The emission levels of other frequencies are very lower than the limit and not show in test report.*