

FCC RF Test Report

(FHSS)

Report No.: JYTSZ-R12-2400908

Applicant: Shenzhen RodinBell Technology Co., Ltd.

Address of Applicant: 905#, Block B, Xinghe WORLD, Wuhe Avenue, Longgang District, Shenzhen City, PRC

Equipment Under Test (EUT)

Product Name: 16-port UHF RFID Module

Model No.: M-704

Trade Mark: N/A

FCC ID: 2AKQD-M-704

Applicable Standards: FCC CFR Title 47 Part 15C (§15.247)

Date of Sample Receipt: 30 Jul., 2024

Date of Test: 31 Jul., to 30 Aug., 2024

Date of Report Issued: 20 Sep., 2024

Test Result: PASS

Tested by: _____**Date:** _____

20 Sep., 2024

Reviewed by: _____**Date:** _____

20 Sep., 2024

Approved by: _____**Date:** _____

20 Sep., 2024

Manager

This equipment has been shown to be capable of compliance with the applicable technical standards as indicated in the measurement report and was tested in accordance with the measurement procedures specified in above the application standard version. Test results reported herein relate only to the item(s) tested.

This document cannot be reproduced except in full, without prior written approval of the Company. Any unauthorized alteration, forgery or falsification of the content or appearance of this document is unlawful and offenders may be prosecuted to the fullest extent of the law. Unless otherwise stated the results shown in this test report refer only to the sample(s) tested and such sample(s) are retained for 90 days only.

1 Version

Version No.	Date	Description
<i>00</i>	<i>21 Aug., 2024</i>	<i>Original</i>
<i>01</i>	<i>20 Sep., 2024</i>	<i>Update page 5, 18.</i>

2 Contents

	Page
Cover Page	1
1 Version	2
2 Contents	3
3 General Information	4
3.1 Client Information	4
3.2 General Description of E.U.T.	4
3.3 Test Mode and Test Environment	5
3.4 Description of Test Auxiliary Equipment	5
3.5 Measurement Uncertainty	5
3.6 Additions to, Deviations, or Exclusions From the Method.....	5
3.7 Laboratory Facility	5
3.8 Laboratory Location.....	6
3.9 Test Instruments List	6
4 Measurement Setup and Procedure	8
4.1 Test Channel	8
4.2 Test Setup	8
4.3 Test Procedure	10
5 Test Results	11
5.1 Summary	11
5.1.1 Clause and data summary	11
5.1.2 Test Limit.....	12
5.2 Antenna Requirement	13
5.3 Conducted Output Power	14
5.4 20dB Occupied Bandwidth	15
5.5 Carrier Frequencies Separation	16
5.6 Hopping Channel Number.....	17
5.7 Dwell Time.....	18
5.8 Spurious Emission.....	19
5.8.1 Band-edge Emission.....	19
5.8.2 Conducted Spurious Emission.....	20
5.8.3 Emissions in Restricted Frequency Bands	21
5.8.4 Emissions in Non-restricted Frequency Bands.....	25

3 General Information

3.1 Client Information

Applicant:	Shenzhen RodinBell Technology Co., Ltd.
Address:	905#, Block B, Xinghe WORLD, Wuhe Avenue, Longgang District, Shenzhen City, PRC
Manufacturer:	Shenzhen RodinBell Technology Co., Ltd.
Address:	905#, Block B, Xinghe WORLD, Wuhe Avenue, Longgang District, Shenzhen City, PRC

3.2 General Description of E.U.T.

Product Name:	16-port UHF RFID Module
Model No.:	M-704
Operation Frequency:	902 MHz - 928 MHz
Number of Channel:	51
Modulation Technology:	ASK
Antenna Type:	External Antenna
Antenna Gain:	1.5 dBi
Power Supply:	DC 4.8V
Test Sample Condition:	The test samples were provided in good working order with no visible defects.

3.3 Test Mode and Test Environment

Test Modes:	
Non-hopping mode:	Keep the EUT in continuous transmitting mode.
Hopping mode:	Keep the EUT in hopping mode.
Remark:	
<ol style="list-style-type: none"> For spurious emission of below 1GHz, pre-scan lowest, middle and highest channel, found lowest channel was worse case mode. The report only reflects the test data of worst mode. The product has 8 antenna ports, each antenna port is the same, and can be separately launched, but can not be launched at the same time, is time-sharing emission; The antenna does not support MIMO, so select antenna port 1 for testing. 	
Operating Environment:	
Temperature:	15°C ~ 35°C
Humidity:	20 % ~ 75 % RH
Atmospheric Pressure:	1008 mbar
Voltage:	Nominal: 4.8 Vdc
Test Engineer:	Alan Chen (Conducted measurement) Robin Gu (Radiated measurement)

3.4 Description of Test Auxiliary Equipment

The EUT has been tested as an independent unit.

3.5 Measurement Uncertainty

Parameter	Expanded Uncertainty (Confidence of 95%(U = 2Uc(y)))
Radiated Emission (30MHz ~ 200MHz) (3m SAC)	4.6 dB
Radiated Emission (200MHz ~ 1000MHz) (3m SAC)	5.8 dB
Radiated Emission (1GHz ~ 6GHz) (3m FAR)	4.95 dB
Radiated Emission (6GHz ~ 18GHz) (3m FAR)	5.23 dB
Note: All the measurement uncertainty value were shown with a coverage k=2 to indicate 95% level of confidence. The measurement data show herein meets or exceeds the CISPR measurement uncertainty values specified in CISPR 16-4-2 and can be compared directly to specified limit to determine compliance.	

3.6 Additions to, Deviations, or Exclusions From the Method

No

3.7 Laboratory Facility

The test facility is recognized, certified, or accredited by the following organizations:

- FCC - Designation No.: CN1211**
 JianYan Testing Group Shenzhen Co., Ltd. has been accredited as a testing laboratory by FCC(Federal Communications Commission). The test firm Registration No. is 727551.
- ISED – CAB identifier.: CN0021**
 The 3m Semi-anechoic chamber and 10m Semi-anechoic chamber of JianYan Testing Group Shenzhen Co., Ltd. has been Registered by Certification and Engineering Bureau of Industry Canada for radio equipment testing with Registration No.: 10106A-1.
- CNAS - Registration No.: CNAS L15527**
 JianYan Testing Group Shenzhen Co., Ltd. is accredited to ISO/IEC 17025:2017 General Requirements for the Competence of Testing and Calibration laboratories for the competence of testing. The Registration No. is CNAS L15527.
- A2LA - Registration No.: 4346.01**
 This laboratory is accredited in accordance with the recognized International Standard ISO/IEC 17025:2017 General requirements for the competence of testing and calibration laboratories. The test scope can be found as below link: <https://portal.a2la.org/scopepdf/4346-01.pdf>

3.8 Laboratory Location

JianYan Testing Group Shenzhen Co., Ltd.
 Address: No.101, Building 8, Innovation Wisdom Port, No.155 Hongtian Road, Huangpu Community, Xinqiao Street, Bao'an District, Shenzhen, Guangdong, People's Republic of China.
 Tel: +86-755-23118282, Fax: +86-755-23116366
 Email: info-JYTee@lets.com, Website: <http://jyt.lets.com>

3.9 Test Instruments List

Radiated Emission(3m SAC):					
Test Equipment	Manufacturer	Model No.	Manage No.	Cal. Date (mm-dd-yy)	Cal. Due date (mm-dd-yy)
3m SAC	ETS	9m*6m*6m	WXJ001-1	04-14-2021	04-13-2026
Loop Antenna	Schwarzbeck	FMZB 1519 B	WXJ002-4	01-05-2024	01-04-2025
BiConiLog Antenna	Schwarzbeck	VULB9163	WXJ002	01-09-2024	01-08-2025
Horn Antenna	Schwarzbeck	BBHA9120D	WXJ002-2	01-05-2024	01-04-2025
Horn Antenna	Schwarzbeck	BBHA9170	WXJ002-5	12-28-2023	12-27-2024
Pre-amplifier (30MHz ~ 1GHz)	Schwarzbeck	BBV9743B	WXJ001-2	12-27-2023	12-26-2024
Pre-amplifier (1GHz ~ 18GHz)	SKET	LNPA_0118G-50	WXJ001-3	12-27-2023	12-26-2024
Pre-amplifier (18GHz ~ 40GHz)	RF System	TRLA-180400G45B	WXJ002-7	12-28-2023	12-27-2024
EMI Test Receiver	Rohde & Schwarz	ESRP7	WXJ003-1	12-27-2023	12-26-2024
Spectrum Analyzer	Rohde & Schwarz	FSP 30	WXJ004	12-27-2023	12-26-2024
Spectrum Analyzer	KEYSIGHT	N9010B	WXJ004-2	09-25-2023	09-24-2024
Coaxial Cable (30MHz ~ 1GHz)	JYTSZ	JYT3M-1G-NN-8M	WXG001-4	01-17-2024	01-16-2025
Coaxial Cable (1GHz ~ 18GHz)	JYTSZ	JYT3M-18G-NN-8M	WXG001-5	01-17-2024	01-16-2025
Coaxial Cable (18GHz ~ 40GHz)	JYTSZ	JYT3M-40G-SS-8M	WXG001-7	01-17-2024	01-16-2025
Band Reject Filter Group	Tonscend	JS0806-F	WXJ089	N/A	
Test Software	Tonscend	TS+	Version: 3.0.0.1		
EMI Test Software	AUDIX	E3	Version: 6.110919b		

Radiated Emission(3m FAR):					
Test Equipment	Manufacturer	Model No.	Manage No.	Cal. Date (mm-dd-yy)	Cal. Due date (mm-dd-yy)
3m FAR	YUNYI	9m*6m*6m	WXJ097	06-15-2023	06-14-2028
BiConiLog Antenna	Schwarzbeck	VULB9163	WXJ097-2	06-26-2024	06-25-2025
Biconical Antenna	Schwarzbeck	VUBA9117	WXJ002-1	07-01-2024	06-30-2027
Horn Antenna	Schwarzbeck	BBHA9120D	WXJ097-3	06-16-2024	06-15-2025
Horn Antenna	Schwarzbeck	BBHA9120D	WXJ002-3	12-28-2023	12-27-2024
Horn Antenna	Schwarzbeck	BBHA9170	WXJ002-5	12-28-2023	12-27-2024
Horn Antenna	Schwarzbeck	BBHA9170	WXJ002-6	12-28-2023	12-27-2024
Pre-amplifier (30MHz ~ 1GHz)	YUNYI	PAM-310N	WXJ097-5	04-24-2024	04-23-2025
Pre-amplifier (1GHz ~ 18GHz)	YUNYI	PAM-118N	WXJ097-6	04-24-2024	04-23-2025
Pre-amplifier (18GHz ~ 40GHz)	RF System	TRLA-180400G45B	WXJ002-7	12-27-2023	12-26-2024
EMI Test Receiver	Rohde & Schwarz	ESCI3	WXJ003	12-27-2023	12-26-2024
Spectrum Analyzer	Rohde & Schwarz	FSP 30	WXJ004	12-27-2023	12-26-2024
Spectrum Analyzer	KEYSIGHT	N9010B	WXJ081-1	06-11-2024	06-10-2025
Coaxial Cable (30MHz ~ 1GHz)	JYTSZ	JYT3M-1G-NN-13M	WXG097-1	08-01-2023	07-31-2024
				07-30-2024	07-29-2025
Coaxial Cable (1GHz ~ 18GHz)	JYTSZ	JYT3M-18G-NN-8M	WXG097-2	08-01-2023	07-31-2024
				07-30-2024	07-29-2025
Coaxial Cable (18GHz ~ 40GHz)	JYTSZ	JYT3M-40G-SS-8M	WXG097-3	08-01-2023	07-31-2024
				07-30-2024	07-29-2025
High Band Reject Filter Group	Tonscend	JS0806-F	WXJ089	N/A	
Low Band Reject Filter Group	Tonscend	JS0806-F	WXJ097-4	N/A	
Test Software	Tonscend	TS+	Version: 5.0.0		

Conducted Method:					
Test Equipment	Manufacturer	Model No.	Manage No.	Cal. Date (mm-dd-yy)	Cal. Due date (mm-dd-yy)
Spectrum Analyzer	Keysight	N9010B	WXJ004-3	09-25-2023	09-24-2024

4 Measurement Setup and Procedure

4.1 Test Channel

According to ANSI C63.10-2013 chapter 5.6.1 Table 4 requirement, select lowest channel, middle channel, and highest channel in the frequency range in which device operates for testing. The detailed frequency points are as follows:

Channel No.	Frequency (MHz)	Channel No.	Frequency (MHz)	Channel No.	Frequency (MHz)
0	902.5	17	911.0	34	919.5
1	903.0	18	911.5	35	920.0
2	903.5	19	912.0	36	920.5
3	904.0	20	912.5	37	921.0
4	904.5	21	913.0	38	921.5
5	905.0	22	913.5	39	922.0
6	905.5	23	914.0	40	922.5
7	906.0	24	914.5	41	923.0
8	906.5	25	915.0	42	923.5
9	907.0	26	915.5	43	924.0
10	907.5	27	916.0	44	924.5
11	908.0	28	916.5	45	925.0
12	908.5	29	917.0	46	925.5
13	909.0	30	917.5	47	926.0
14	909.5	31	918.0	48	926.5
15	910.0	32	918.5	49	927.0
16	910.5	33	919.0	50	927.5

Remark: Channel 0, 25 & 50 selected for tested.

4.2 Test Setup

1) Conducted emission measurement:

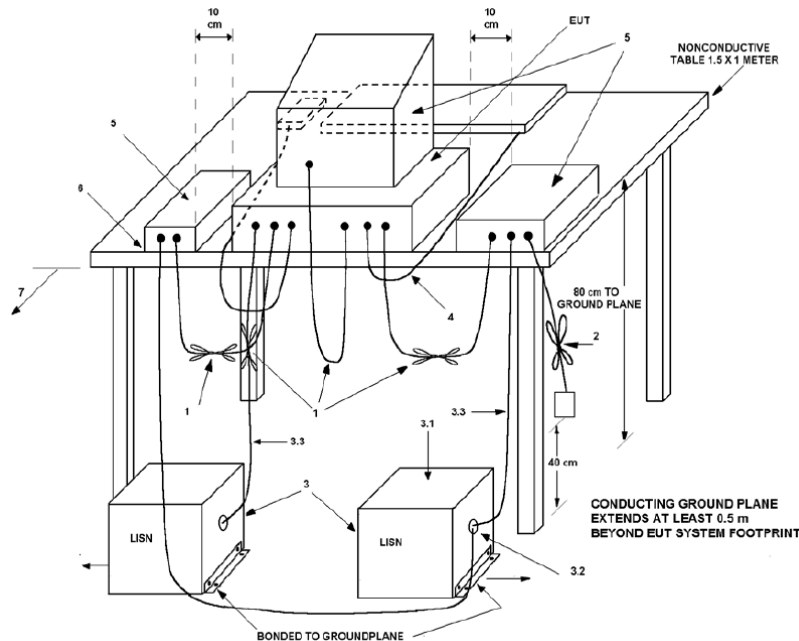

Note: The detailed descriptions please refer to Figure 8 of ANSI C63.4:2014.

2) Radiated emission measurement:

Below 1GHz (3m SAC)

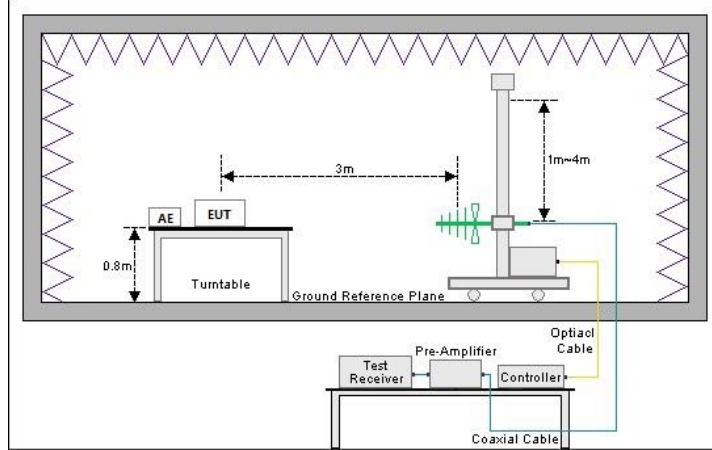

Above 1GHz (3m SAC or 3m FAR)

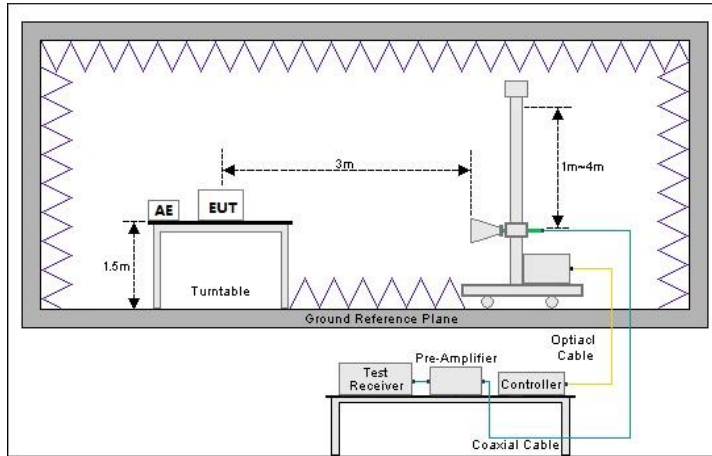

3) Conducted test method

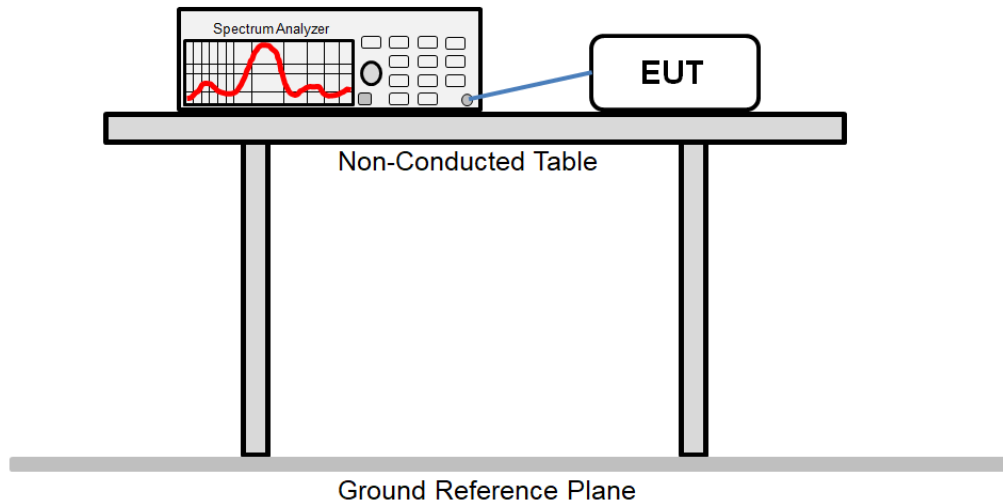

4.3 Test Procedure

Test method	Test step
Radiated emission	<p>For below 1GHz:</p> <ol style="list-style-type: none"> The EUT was placed on the tabletop of a rotating table 0.8 m the ground at a 3 m semi anechoic chamber. The measurement distance from the EUT to the receiving antenna is 3 m. EUT works in each mode of operation that needs to be tested, and having the EUT continuously working, respectively on 3 axis (X, Y & Z) and considered typical configuration to obtain worst position. The highest signal levels relative to the limit shall be determined by rotating the EUT from 0° to 360° and with varying the measurement antenna height between 1 m and 4 m in vertical and horizontal polarizations. Open the test software to control the test antenna and test turntable. Perform the test, save the test results, and export the test data. <p>For above 1GHz:</p> <ol style="list-style-type: none"> The EUT was placed on the tabletop of a rotating table 1.5 m the ground at a 3 m fully anechoic room. The measurement distance from the EUT to the receiving antenna is 3 m. EUT works in each mode of operation that needs to be tested, and having the EUT continuously working, respectively on 3 axis (X, Y & Z) and considered typical configuration to obtain worst position. The highest signal levels relative to the limit shall be determined by rotating the EUT from 0° to 360° and with varying the measurement antenna height between 1 m and 4 m in vertical and horizontal polarizations. Open the test software to control the test antenna and test turntable. Perform the test, save the test results, and export the test data.
Conducted test method	<ol style="list-style-type: none"> The antenna port of EUT was connected to the test port of the test system through an RF cable. The EUT is keeping in continuous transmission mode and tested in all modulation modes. Open the test software, prepare a test plan, and control the system through the software. After the test is completed, the test report is exported through the test software.

5 Test Results

5.1 Summary

5.1.1 Clause and data summary

Test items	Standard clause	Test data	Result
Antenna Requirement	15.203 15.247 (b)(4)	See Section 5.2	Pass
AC Power Line Conducted Emission	15.207	N/A	N/A
Conducted Output Power	15.247 (b)(2)	See Section 5.3	Pass
20dB Occupied Bandwidth	15.247 (a)(1)(i)	See Section 5.4	Pass
Carrier Frequencies Separation	15.247 (a)(1)	See Section 5.5	Pass
Hopping Channel Number	5.247 (a)(1)(i)	See Section 5.6	Pass
Dwell Time	15.247 (a)(1)(i)	See Section 5.7	Pass
Spurious Emission	15.205 15.209 15.247 (d)	See Section 5.8	Pass
<p>Remark:</p> <ol style="list-style-type: none"> 1. Pass: The EUT complies with the essential requirements in the standard. 2. N/A: Not Applicable. 3. The cable insertion loss used by "RF Output Power" and other conduction measurement items is 0.5dB (provided by the customer). 			
Test Method:	ANSI C63.10-2013 KDB 558074 D01 15.247 Meas Guidance v05r02		

5.1.2 Test Limit

Test items	Limit																														
Conducted Output Power	For frequency hopping systems operating in the 902-928 MHz band: 1 watt for systems employing at least 50 hopping channels; and, 0.25 watts for systems employing less than 50 hopping channels, but at least 25 hopping channels, as permitted under paragraph (a)(1)(i) of this section.																														
20dB Occupied Bandwidth Hopping Channel Number Dwell Time	For frequency hopping systems operating in the 902-928 MHz band: if the 20 dB bandwidth of the hopping channel is less than 250 kHz, the system shall use at least 50 hopping frequencies and the average time of occupancy on any frequency shall not be greater than 0.4 seconds within a 20 second period; if the 20 dB bandwidth of the hopping channel is 250 kHz or greater, the system shall use at least 25 hopping frequencies and the average time of occupancy on any frequency shall not be greater than 0.4 seconds within a 10 second period. The maximum allowed 20 dB bandwidth of the hopping channel is 500 kHz.																														
Carrier Frequencies Separation	Frequency hopping systems shall have hopping channel carrier frequencies separated by a minimum of 25 kHz or the 20 dB bandwidth of the hopping channel, whichever is greater																														
Spurious Emission	<p>In any 100 kHz bandwidth outside the frequency band in which the spread spectrum or digitally modulated intentional radiator is operating, the radio frequency power that is produced by the intentional radiator shall be at least 20 dB below that in the 100 kHz bandwidth within the band that contains the highest level of the desired power, based on either an RF conducted or a radiated measurement, provided the transmitter demonstrates compliance with the peak conducted power limits. If the transmitter complies with the conducted power limits based on the use of RMS averaging over a time interval, as permitted under paragraph (b)(3) of this section, the attenuation required under this paragraph shall be 30 dB instead of 20 dB. Attenuation below the general limits specified in §15.209(a) is not required. In addition, radiated emissions which fall in the restricted bands, as defined in §15.205(a), must also comply with the radiated emission limits specified in §15.209(a) (see §15.205(c)):</p> <table border="1"> <thead> <tr> <th rowspan="2">Frequency (MHz)</th> <th colspan="2">Limit (dBµV/m)</th> <th rowspan="2">Detector</th> </tr> <tr> <th>@ 3m</th> <th>@ 10m</th> </tr> </thead> <tbody> <tr> <td>30 – 88</td> <td>40.0</td> <td>30.0</td> <td>Quasi-peak</td> </tr> <tr> <td>88 – 216</td> <td>43.5</td> <td>33.5</td> <td>Quasi-peak</td> </tr> <tr> <td>216 – 960</td> <td>46.0</td> <td>36.0</td> <td>Quasi-peak</td> </tr> <tr> <td>960 – 1000</td> <td>54.0</td> <td>44.0</td> <td>Quasi-peak</td> </tr> </tbody> </table> <p>Note: The more stringent limit applies at transition frequencies.</p> <table border="1"> <thead> <tr> <th rowspan="2">Frequency</th> <th colspan="2">Limit (dBµV/m) @ 3m</th> </tr> <tr> <th>Average</th> <th>Peake</th> </tr> </thead> <tbody> <tr> <td>Above 1 GHz</td> <td>54.0</td> <td>74.0</td> </tr> </tbody> </table> <p>Note: The measurement bandwidth shall be 1 MHz or greater.</p>	Frequency (MHz)	Limit (dBµV/m)		Detector	@ 3m	@ 10m	30 – 88	40.0	30.0	Quasi-peak	88 – 216	43.5	33.5	Quasi-peak	216 – 960	46.0	36.0	Quasi-peak	960 – 1000	54.0	44.0	Quasi-peak	Frequency	Limit (dBµV/m) @ 3m		Average	Peake	Above 1 GHz	54.0	74.0
Frequency (MHz)	Limit (dBµV/m)		Detector																												
	@ 3m	@ 10m																													
30 – 88	40.0	30.0	Quasi-peak																												
88 – 216	43.5	33.5	Quasi-peak																												
216 – 960	46.0	36.0	Quasi-peak																												
960 – 1000	54.0	44.0	Quasi-peak																												
Frequency	Limit (dBµV/m) @ 3m																														
	Average	Peake																													
Above 1 GHz	54.0	74.0																													

5.2 Antenna Requirement

Standard requirement:	FCC Part 15 C Section 15.203 & 247(b)
<p>15.203 requirement: An intentional radiator shall be designed to ensure that no antenna other than that furnished by the responsible party shall be used with the device. The use of a permanently attached antenna or of an antenna that uses a unique coupling to the intentional radiator, the manufacturer may design the unit so that a broken antenna can be replaced by the user, but the use of a standard antenna jack or electrical connector is prohibited.</p> <p>15.247(b) (4) requirement: (4) The conducted output power limit specified in paragraph (b) of this section is based on the use of antennas with directional gains that do not exceed 6 dBi. Except as shown in paragraph (c) of this section, if transmitting antennas of directional gain greater than 6 dBi are used, the conducted output power from the intentional radiator shall be reduced below the stated values in paragraphs (b)(1), (b)(2), and (b)(3) of this section, as appropriate, by the amount in dB that the directional gain of the antenna exceeds 6 dBi.</p>	
E.U.T Antenna:	
<p>The EUT antenna is an external antenna which permanently attached, and the best case gain of the antenna is 1.50 dBi. See product internal photos for details.</p>	

5.3 Conducted Output Power

Test channel	Maximum Output Power (dBm)	Limit (dBm)	Result
Lowest channel	29.61	30.00	Pass
Middle channel	29.11	30.00	Pass
Highest channel	29.82	30.00	Pass

Test plot as follows:

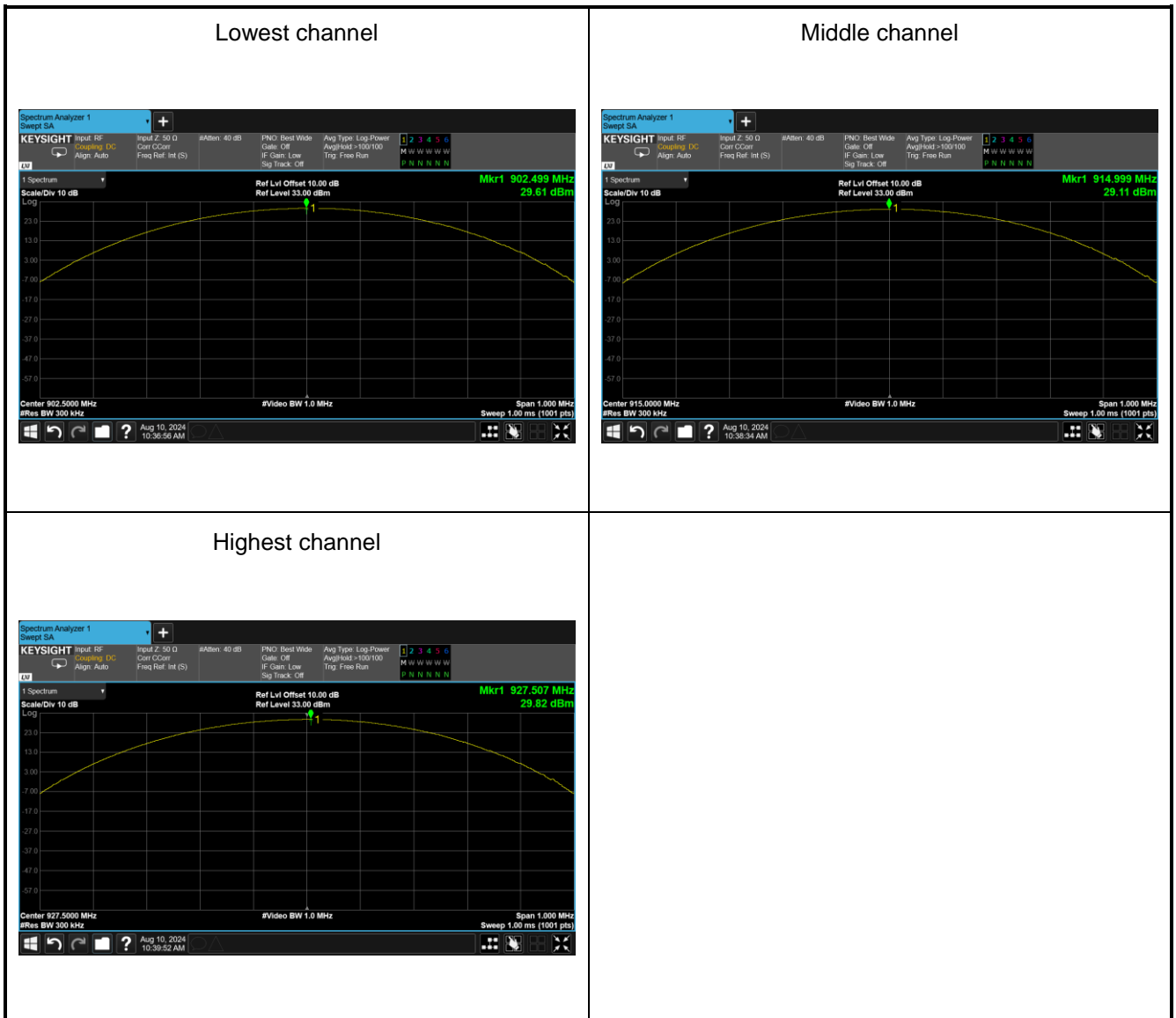

5.4 20dB Occupied Bandwidth

Test channel	20dB Occupy Bandwidth (kHz)	Limit (kHz)	Result
Lowest channel	130.2	$BW_{20dB} \leq 250$	Pass
Middle channel	130.0	$BW_{20dB} \leq 250$	Pass
Highest channel	130.9	$BW_{20dB} \leq 250$	Pass

Test plot as follows:

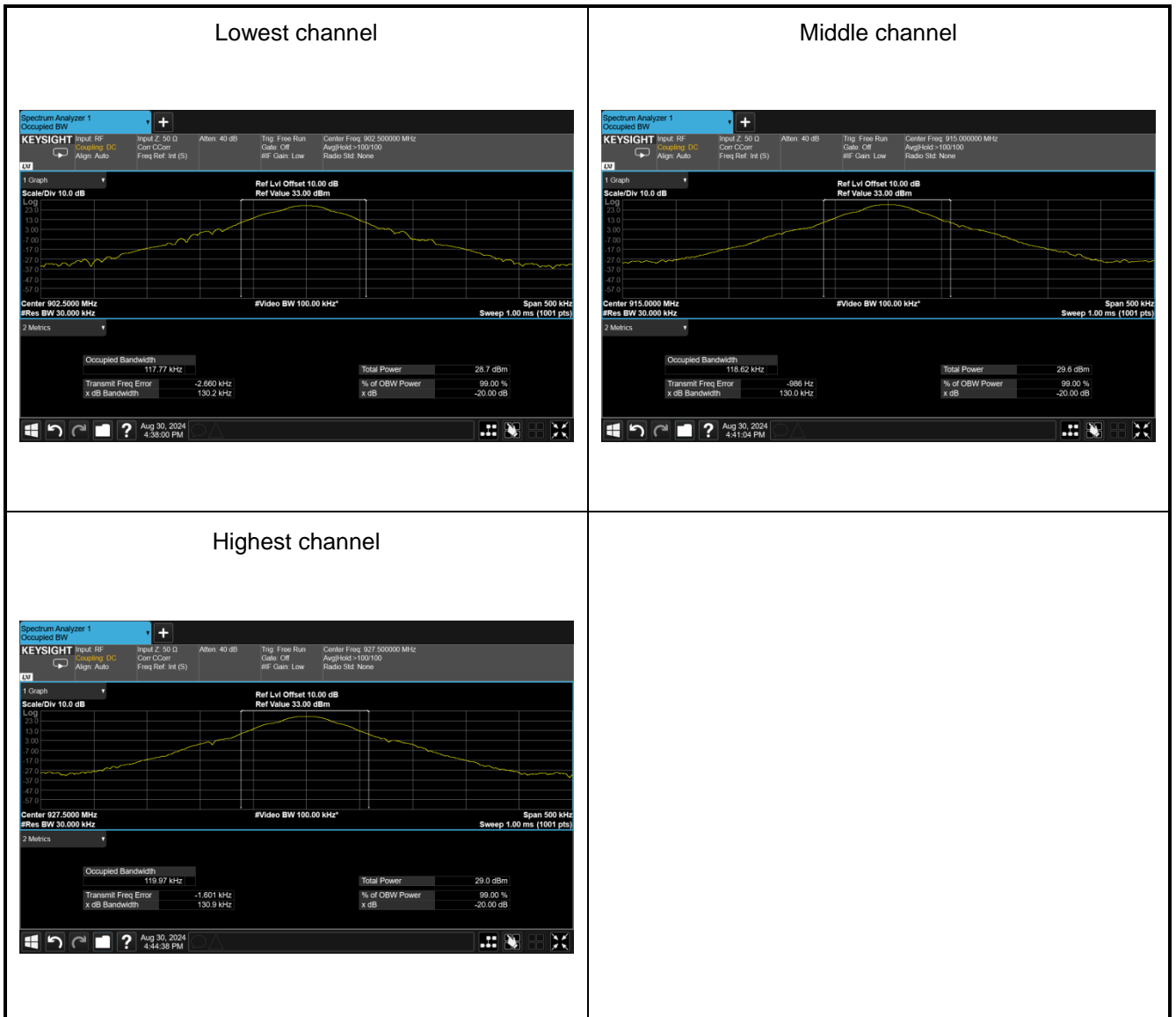

5.5 Carrier Frequencies Separation

Test channel	Carrier Frequencies Separation (kHz)	Limit (kHz)	Result
Lowest channel	500	126.0	Pass
Middle channel	500	126.0	Pass
Highest channel	500	126.0	Pass

Test plot as follows:

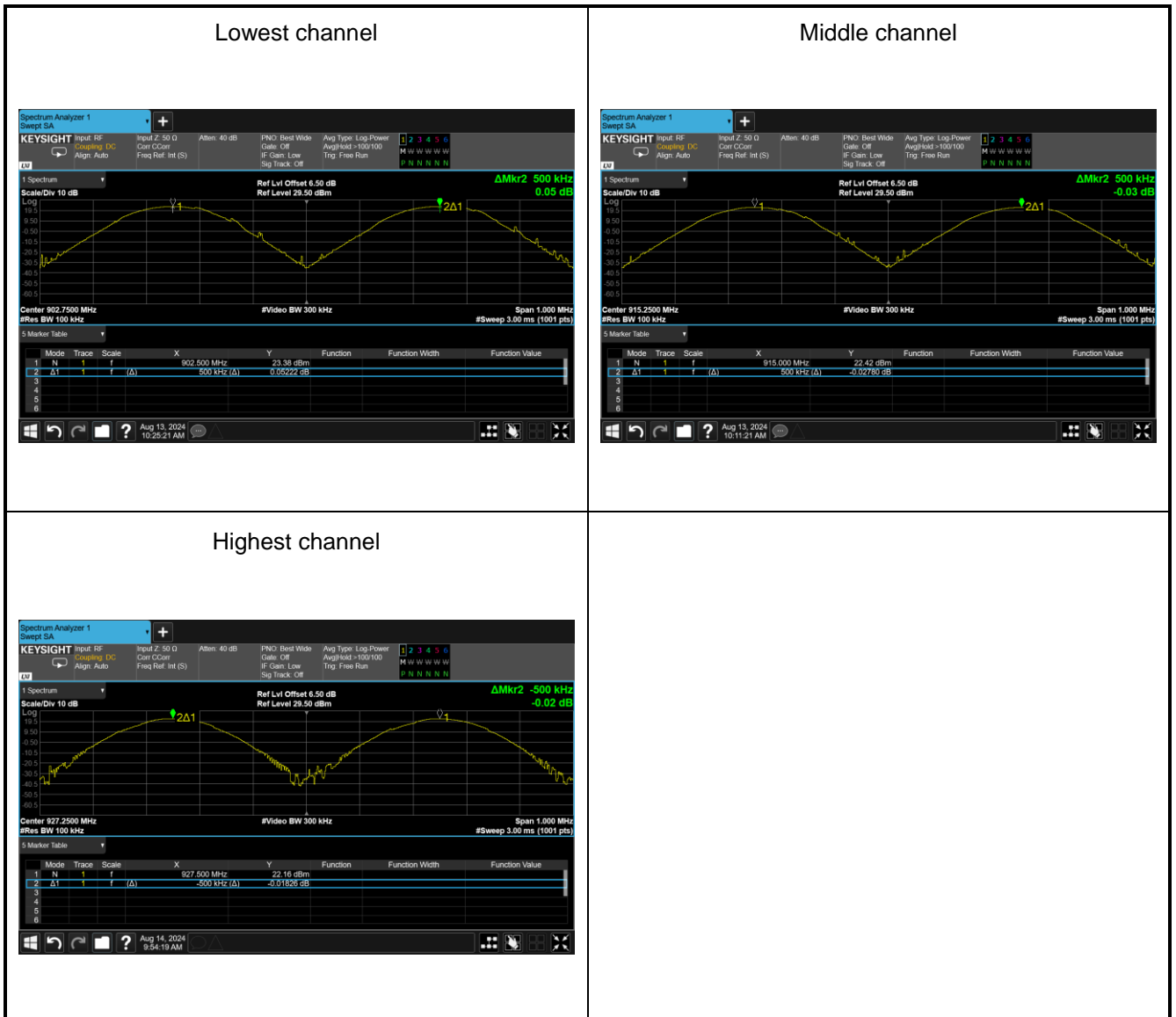

5.6 Hopping Channel Number

Hopping channel numbers	Limit	Result
51	$N_{ch} \geq 50$	Pass

Test plot as follows:

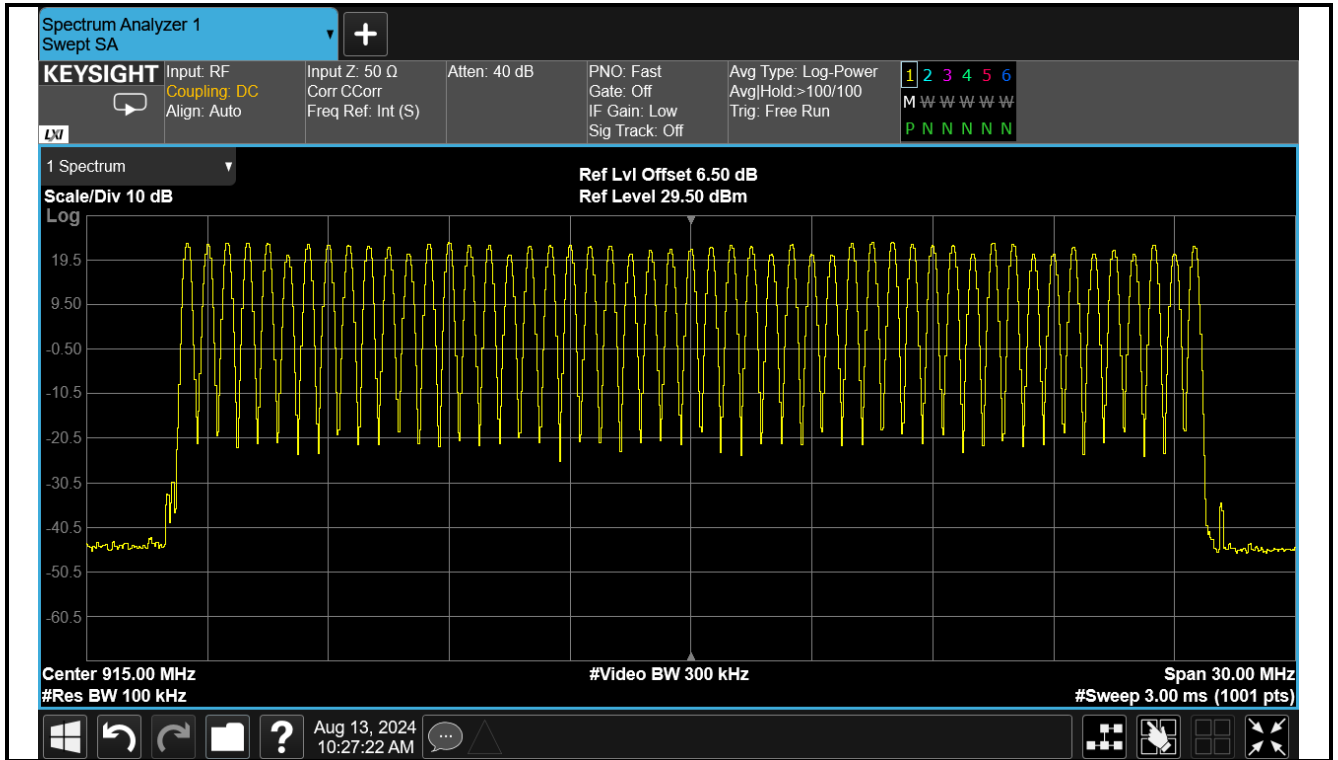

5.7 Dwell Time

T_{on} (s)	Hopping numbers (20 s period)	Dwell time (s)	Limit (s)	Result
0.0394	9	0.3546	0.4	Pass

Note:

- T_{on} is time per hop.
- Dwell time = $T_{on} * \text{Hopping numbers}$.

Test plot as follows:

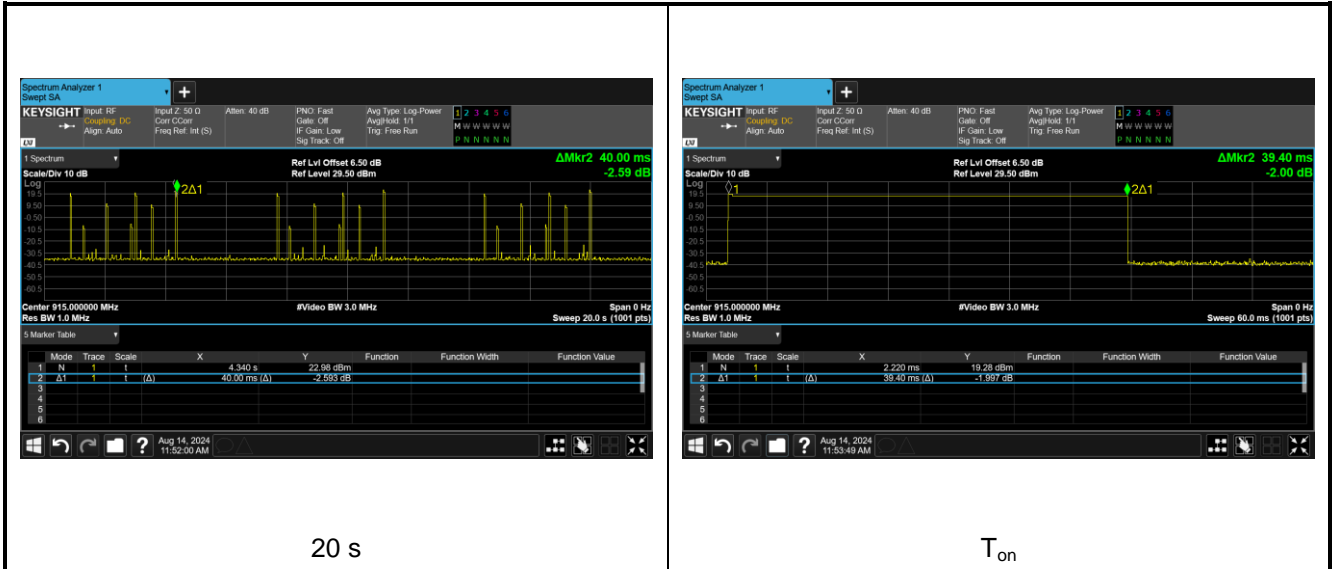

5.8 Spurious Emission

5.8.1 Band-edge Emission

Lowest Channel

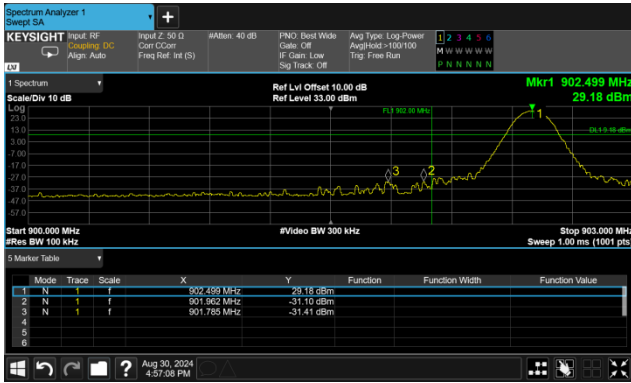

No-hopping mode

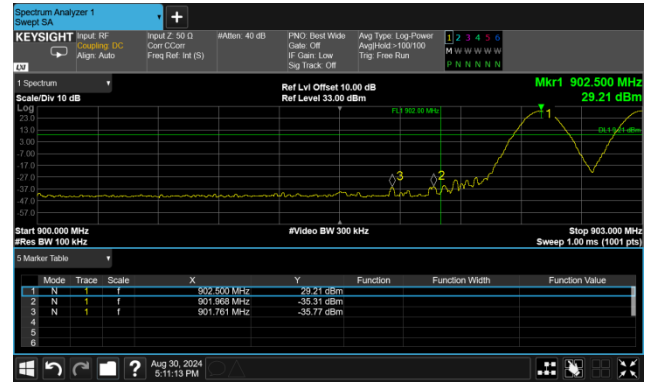

Hopping mode

Highest Channel



No-hopping mode



Hopping mode

5.8.2 Conducted Spurious Emission

Lowest channel

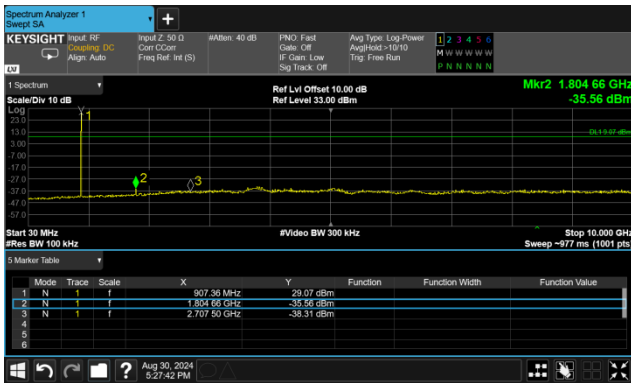

30MHz~10GHz

Middle channel

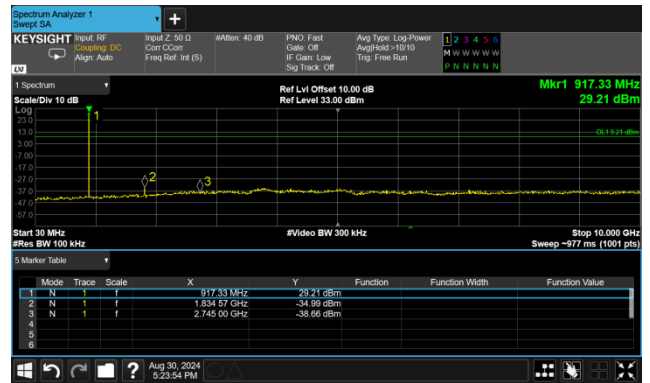

30MHz~10GHz

Highest channel



30MHz~10GHz

5.8.3 Emissions in Restricted Frequency Bands

Product Name:	16-port UHF RFID Module	Product Model:	M-704
Test By:	Alan Chen	Test mode:	Tx mode
Test Channel:	Lowest channel	Polarization:	Vertical
Test Voltage:	AC 120/60Hz		

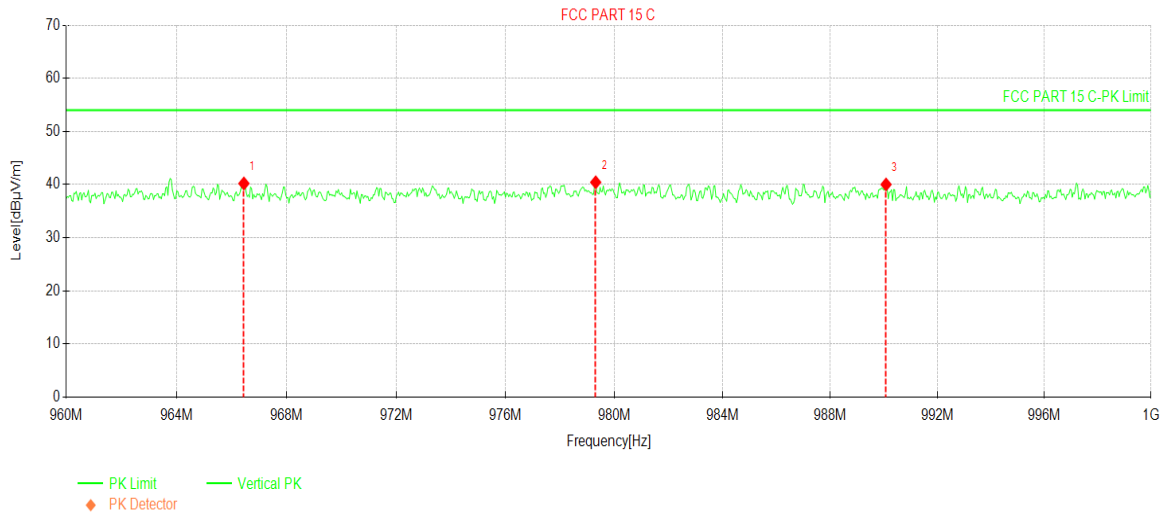

Suspected Data List								
NO.	Freq. [MHz]	Reading [dBµV/m]	Level [dBµV/m]	Factor [dB]	Limit [dBµV/m]	Margin [dB]	Trace	Polarity
1	966.4400	13.57	40.20	26.63	54.00	13.80	PK	Vertical
2	979.3200	13.63	40.43	26.80	54.00	13.57	PK	Vertical
3	990.0800	13.11	40.02	26.91	54.00	13.98	PK	Vertical

Remark:

1. Level = Reading + FactorAntenna Factor + Cable Loss – Preampifier Factor).

Product Name:	16-port UHF RFID Module	Product Model:	M-704
Test By:	Alan Chen	Test mode:	Tx mode
Test Channel:	Lowest channel	Polarization:	Horizontal
Test Voltage:	AC 120/60Hz		

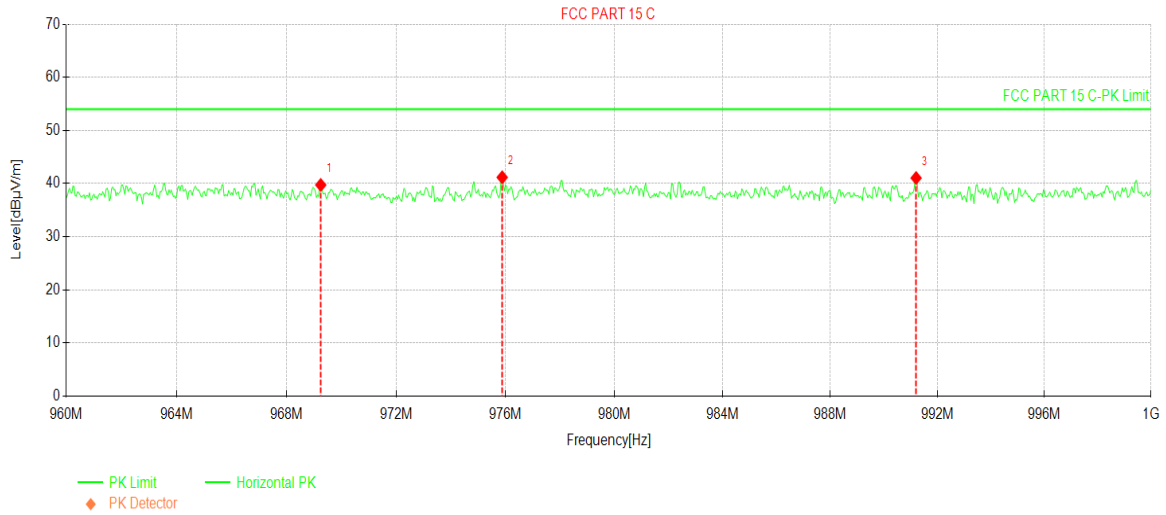

Suspected Data List

NO.	Freq. [MHz]	Reading [dBµV/m]	Level [dBµV/m]	Factor [dB]	Limit [dBµV/m]	Margin [dB]	Trace	Polarity
1	969.2400	13.04	39.74	26.70	54.00	14.26	PK	Horizontal
2	975.8800	14.45	41.18	26.73	54.00	12.82	PK	Horizontal
3	991.2000	14.17	41.05	26.88	54.00	12.95	PK	Horizontal

Remark:

1. Level = Reading + FactorAntenna Factor + Cable Loss – Preamplifier Factor).

Product Name:	16-port UHF RFID Module	Product Model:	M-704
Test By:	Alan Chen	Test mode:	Tx mode
Test Channel:	Highest channel	Polarization:	Vertical
Test Voltage:	AC 120/60Hz		

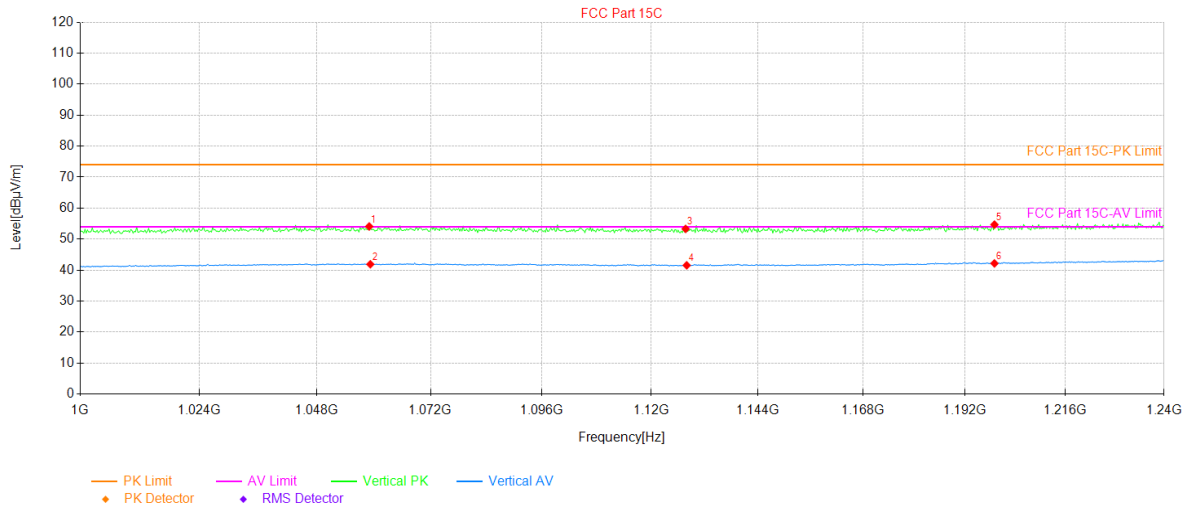

Suspected Data List										
NO.	Freq. [MHz]	Reading [dBµV]	Factor [dB/m]	Level [dBµV/m]	Limit [dBµV/m]	Margin [dB]	Angle [°]	Detector	Verdict	Polarity
1	1059.04	23.34	30.74	54.08	74.00	19.92	8	PK	PASS	Vertical
2	1059.28	11.15	30.74	41.89	54.00	12.11	125	AV	PASS	Vertical
3	1127.68	22.47	30.84	53.31	74.00	20.69	39	PK	PASS	Vertical
4	1127.92	10.70	30.85	41.55	54.00	12.45	271	AV	PASS	Vertical
5	1198.96	23.48	31.21	54.69	74.00	19.31	2	PK	PASS	Vertical
6	1198.96	10.96	31.21	42.17	54.00	11.83	231	AV	PASS	Vertical

Remark:

1. Level = Reading + FactorAntenna Factor + Cable Loss – Pre-amplifier Factor).

Product Name:	16-port UHF RFID Module	Product Model:	M-704
Test By:	Alan Chen	Test mode:	Tx mode
Test Channel:	Highest channel	Polarization:	Horizontal
Test Voltage:	AC 120/60Hz		

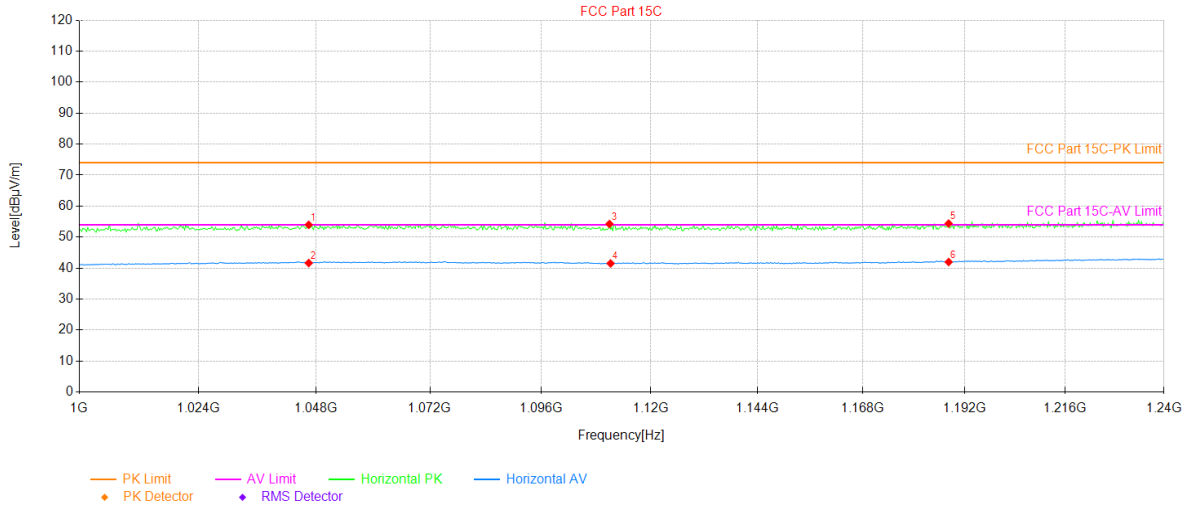

Suspected Data List										
NO.	Freq. [MHz]	Reading [dBµV]	Factor [dB/m]	Level [dBµV/m]	Limit [dBµV/m]	Margin [dB]	Angle [°]	Detector	Verdict	Polarity
1	1046.56	23.25	30.72	53.97	74.00	20.03	155	PK	PASS	Horizontal
2	1046.56	10.93	30.72	41.65	54.00	12.35	164	AV	PASS	Horizontal
3	1110.88	23.48	30.76	54.24	74.00	19.76	115	PK	PASS	Horizontal
4	1111.12	10.76	30.76	41.52	54.00	12.48	0	AV	PASS	Horizontal
5	1188.16	23.24	31.15	54.39	74.00	19.61	133	PK	PASS	Horizontal
6	1188.16	10.83	31.15	41.98	54.00	12.02	285	AV	PASS	Horizontal

Remark:

1. Level = Reading + FactorAntenna Factor + Cable Loss – Preamplifier Factor).

5.8.4 Emissions in Non-restricted Frequency Bands

Below 1GHz:

Product Name:	16-port UHF RFID Module	Product Model:	M-704
Test By:	Alan Chen	Test mode:	Tx mode
Test Frequency:	30 MHz ~ 1 GHz	Polarization:	Vertical
Test Voltage:	AC 120/60Hz		

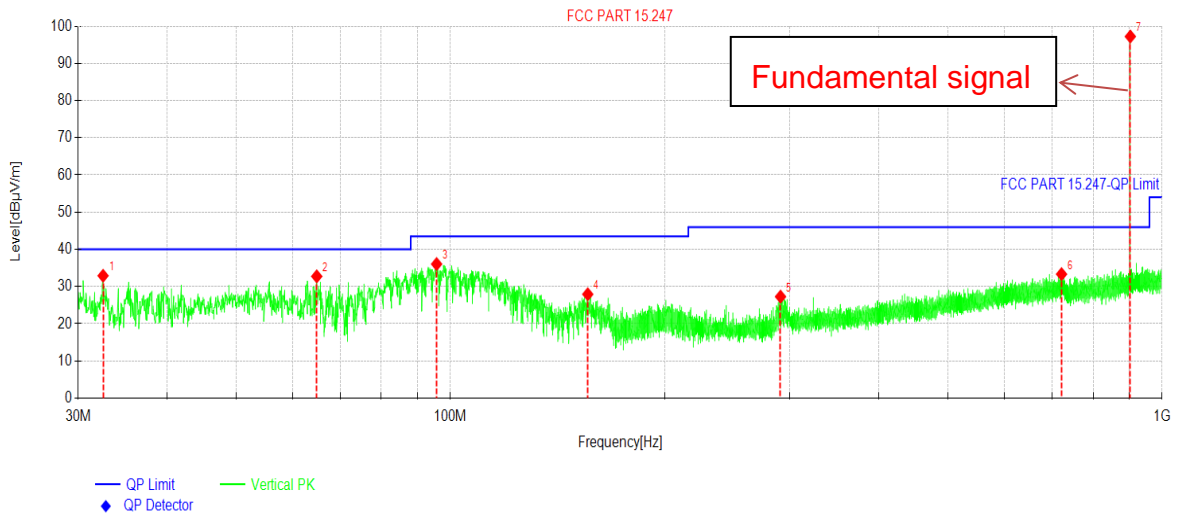

Suspected Data List

NO.	Freq. [MHz]	Reading [dBµV/m]	Factor [dB]	Level [dBµV/m]	Limit [dBµV/m]	Margin [dB]	Trace	Polarity
1	32.5221	48.78	-15.88	32.90	40.00	7.10	PK	Vertical
2	64.9217	47.66	-14.92	32.74	40.00	7.26	PK	Vertical
3	95.6723	51.36	-15.32	36.04	43.50	7.46	PK	Vertical
4	156.0093	45.95	-18.02	27.93	43.50	15.57	PK	Vertical
5	291.0401	40.47	-13.19	27.28	46.00	18.72	PK	Vertical
6	722.4691	38.36	-5.02	33.34	46.00	12.66	PK	Vertical
7	902.5101	99.91	-2.68	97.23	46.00	-51.23	PK	Vertical

Remark:

1. Level = Reading + FactorAntenna Factor + Cable Loss – Preamplifier Factor).

Product Name:	16-port UHF RFID Module	Product Model:	M-704
Test By:	Alan Chen	Test mode:	Tx mode
Test Frequency:	30 MHz ~ 1 GHz	Polarization:	Horizontal
Test Voltage:	AC 120/60Hz		

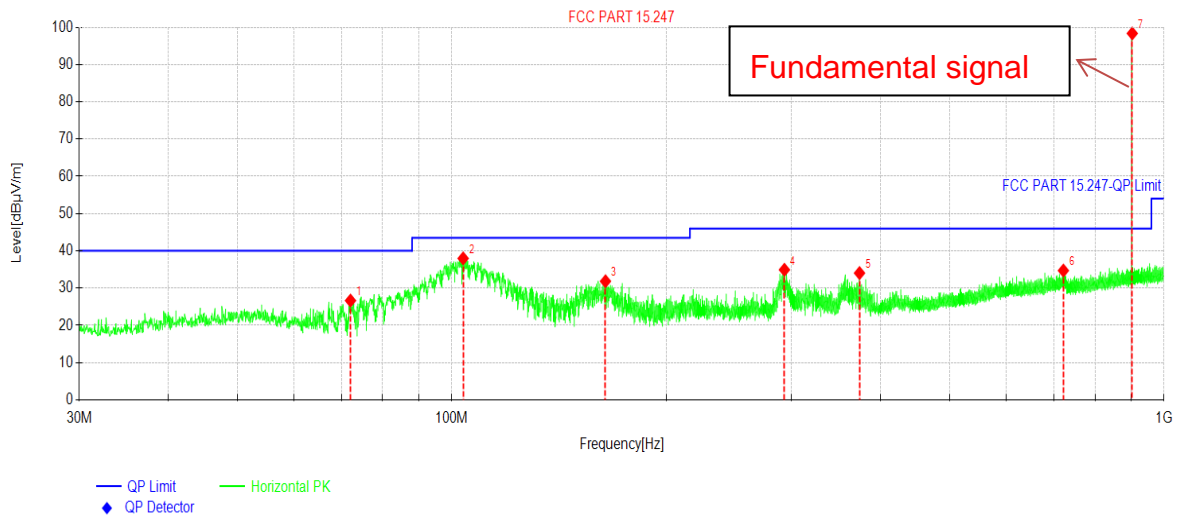

Suspected Data List								
NO.	Freq. [MHz]	Reading [dBµV/m]	Factor [dB]	Level [dBµV/m]	Limit [dBµV/m]	Margin [dB]	Trace	Polarity
1	72.1001	44.40	-17.76	26.64	40.00	13.36	PK	Horizontal
2	103.7722	52.56	-14.59	37.97	43.50	5.53	PK	Horizontal
3	164.4002	49.54	-17.71	31.83	43.50	11.67	PK	Horizontal
4	293.1742	48.06	-13.15	34.91	46.00	11.09	PK	Horizontal
5	373.7367	45.37	-11.34	34.03	46.00	11.97	PK	Horizontal
6	722.4691	39.72	-5.02	34.70	46.00	11.30	PK	Horizontal
7	902.6071	101.02	-2.68	98.34	46.00	-52.34	PK	Horizontal

Remark:

1. Level = Reading + FactorAntenna Factor + Cable Loss – Preamplifier Factor).

Above 1GHz:

902.5MHz:

Product Name:	16-port UHF RFID Module	Product Model:	M-704
Test By:	Alan Chen	Test mode:	Tx mode
Test Frequency:	1 GHz ~ 10 GHz	Polarization:	Vertical
Test Voltage:	AC 120/60Hz		

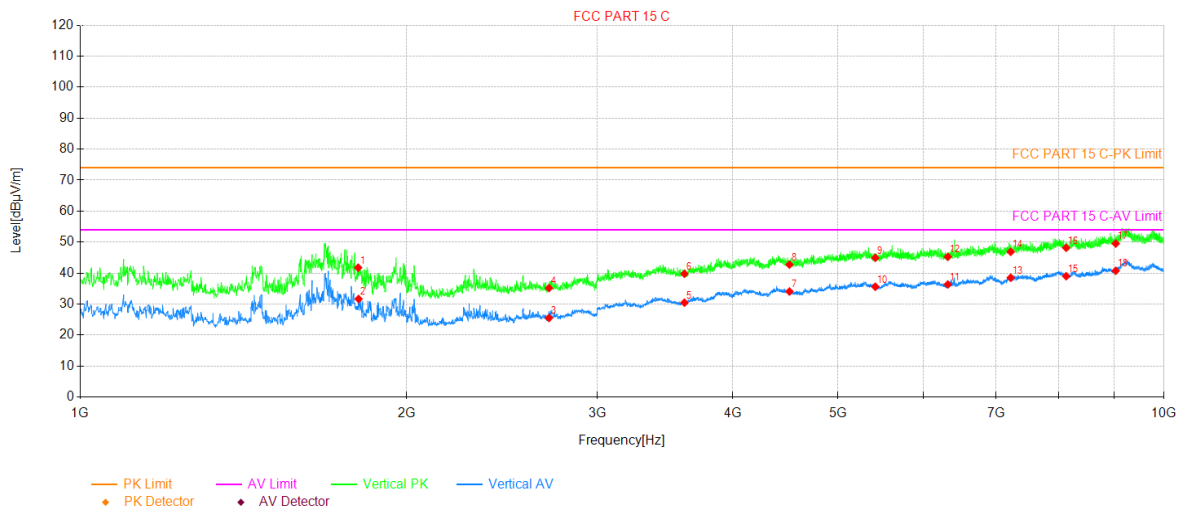

Suspected Data List										
NO.	Freq. [MHz]	Reading [dBµV]	Factor [dB/m]	Level [dBµV/m]	Limit [dBµV/m]	Margin [dB]	Angle [°]	Detector	Verdict	Polarity
1	1805.00	64.16	-22.40	41.76	74.00	32.24	172	PK	PASS	Vertical
2	1806.63	54.06	-22.39	31.67	54.00	22.33	158	AV	PASS	Vertical
3	2707.50	43.15	-17.62	25.53	54.00	28.47	256	AV	PASS	Vertical
4	2707.50	52.80	-17.62	35.18	74.00	38.82	152	PK	PASS	Vertical
5	3610.00	43.23	-12.75	30.48	54.00	23.52	360	AV	PASS	Vertical
6	3610.00	52.54	-12.75	39.79	74.00	34.21	360	PK	PASS	Vertical
7	4512.50	42.66	-8.59	34.07	54.00	19.93	242	AV	PASS	Vertical
8	4512.50	51.34	-8.59	42.75	74.00	31.25	96	PK	PASS	Vertical
9	5415.00	50.91	-5.96	44.95	74.00	29.05	89	PK	PASS	Vertical
10	5415.00	41.57	-5.96	35.61	54.00	18.39	311	AV	PASS	Vertical
11	6317.50	42.19	-5.84	36.35	54.00	17.65	283	AV	PASS	Vertical
12	6317.50	51.11	-5.84	45.27	74.00	28.73	227	PK	PASS	Vertical
13	7220.00	41.86	-3.34	38.52	54.00	15.48	214	AV	PASS	Vertical
14	7220.00	50.22	-3.34	46.88	74.00	27.12	48	PK	PASS	Vertical
15	8122.50	40.88	-1.86	39.02	54.00	14.98	2	AV	PASS	Vertical
16	8122.50	50.03	-1.86	48.17	74.00	25.83	179	PK	PASS	Vertical
17	9025.00	49.18	0.36	49.54	74.00	24.46	227	PK	PASS	Vertical
18	9025.00	40.40	0.36	40.76	54.00	13.24	144	AV	PASS	Vertical

Remark:

1. Level = Reading + FactorAntenna Factor + Cable Loss – Preamplifier Factor).

Product Name:	16-port UHF RFID Module	Product Model:	M-704
Test By:	Alan Chen	Test mode:	Tx mode
Test Frequency:	1 GHz ~ 10 GHz	Polarization:	Horizontal
Test Voltage:	AC 120/60Hz		

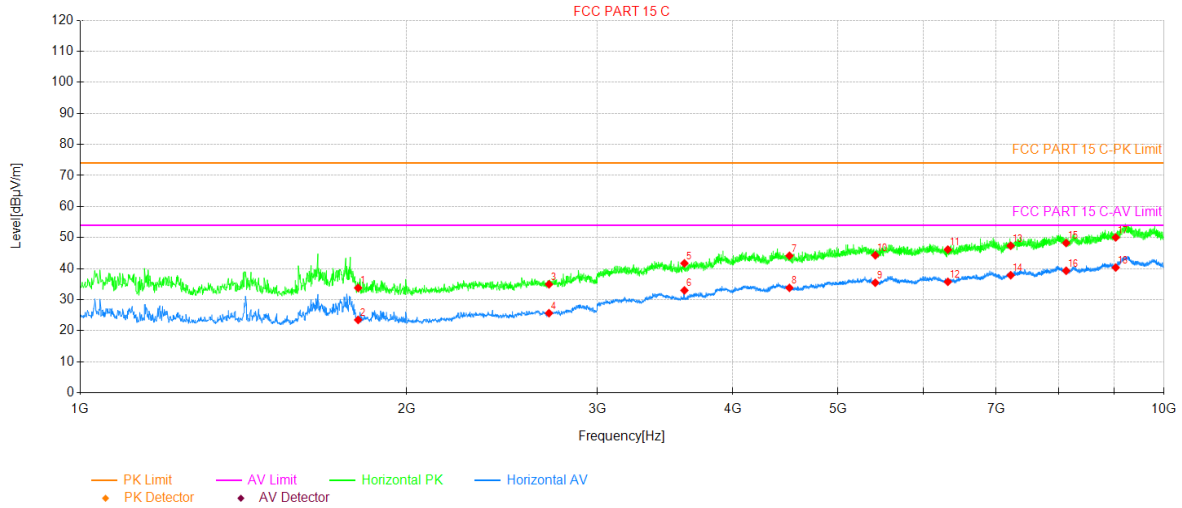

Suspected Data List										
NO.	Freq. [MHz]	Reading [dBμV]	Factor [dB/m]	Level [dBμV/m]	Limit [dBμV/m]	Margin [dB]	Angle [°]	Detector	Verdict	Polarity
1	1805.00	56.21	-22.40	33.81	74.00	40.19	188	PK	PASS	Horizontal
2	1805.00	45.90	-22.40	23.50	54.00	30.50	201	AV	PASS	Horizontal
3	2707.50	52.59	-17.62	34.97	74.00	39.03	63	PK	PASS	Horizontal
4	2707.50	43.29	-17.62	25.67	54.00	28.33	313	AV	PASS	Horizontal
5	3610.00	54.46	-12.75	41.71	74.00	32.29	229	PK	PASS	Horizontal
6	3610.00	45.76	-12.75	33.01	54.00	20.99	229	AV	PASS	Horizontal
7	4512.50	52.75	-8.59	44.16	74.00	29.84	236	PK	PASS	Horizontal
8	4512.50	42.41	-8.59	33.82	54.00	20.18	319	AV	PASS	Horizontal
9	5415.00	41.43	-5.96	35.47	54.00	18.53	167	AV	PASS	Horizontal
10	5415.00	50.27	-5.96	44.31	74.00	29.69	167	PK	PASS	Horizontal
11	6317.50	51.99	-5.84	46.15	74.00	27.85	215	PK	PASS	Horizontal
12	6317.50	41.61	-5.84	35.77	54.00	18.23	112	AV	PASS	Horizontal
13	7220.00	50.70	-3.34	47.36	74.00	26.64	42	PK	PASS	Horizontal
14	7220.00	41.23	-3.34	37.89	54.00	16.11	306	AV	PASS	Horizontal
15	8122.50	50.12	-1.86	48.26	74.00	25.74	98	PK	PASS	Horizontal
16	8122.50	41.18	-1.86	39.32	54.00	14.68	277	AV	PASS	Horizontal
17	9025.00	49.70	0.36	50.06	74.00	23.94	313	PK	PASS	Horizontal
18	9025.00	40.00	0.36	40.36	54.00	13.64	167	AV	PASS	Horizontal

Remark:

1. Level = Reading + FactorAntenna Factor + Cable Loss – Preamplifier Factor).

915MHz:

Product Name:	16-port UHF RFID Module	Product Model:	M-704
Test By:	Alan Chen	Test mode:	Tx mode
Test Frequency:	1 GHz ~ 10 GHz	Polarization:	Vertical
Test Voltage:	AC 120/60Hz		

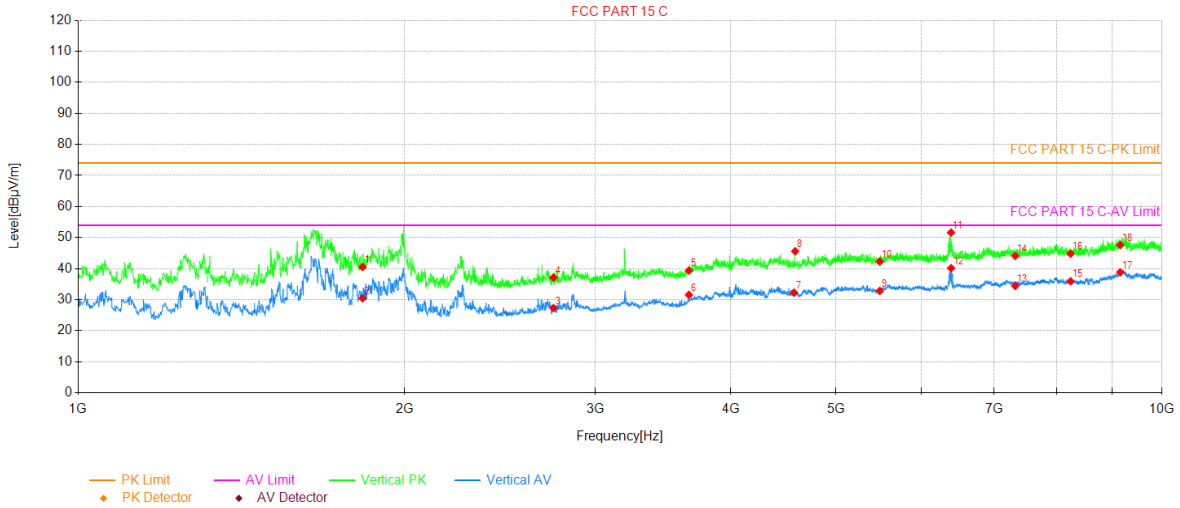

Suspected Data List										
NO.	Freq. [MHz]	Reading [dBμV]	Factor [dB/m]	Level [dBμV/m]	Limit [dBμV/m]	Margin [dB]	Angle [°]	Detector	Verdict	Polarity
1	1830.00	62.80	-22.26	40.54	74.00	33.46	159	PK	PASS	Vertical
2	1830.00	52.72	-22.26	30.46	54.00	23.54	124	AV	PASS	Vertical
3	2745.00	44.73	-17.40	27.33	54.00	26.67	195	AV	PASS	Vertical
4	2745.00	54.55	-17.40	37.15	74.00	36.85	188	PK	PASS	Vertical
5	3660.00	50.96	-11.58	39.38	74.00	34.62	102	PK	PASS	Vertical
6	3660.00	43.15	-11.58	31.57	54.00	22.43	110	AV	PASS	Vertical
7	4575.00	40.91	-8.63	32.28	54.00	21.72	216	AV	PASS	Vertical
8	4586.95	54.25	-8.65	45.60	74.00	28.40	202	PK	PASS	Vertical
9	5490.00	39.06	-6.22	32.84	54.00	21.16	124	AV	PASS	Vertical
10	5490.00	48.51	-6.22	42.29	74.00	31.71	59	PK	PASS	Vertical
11	6387.17	57.15	-5.53	51.62	74.00	22.38	73	PK	PASS	Vertical
12	6388.30	45.70	-5.53	40.17	54.00	13.83	80	AV	PASS	Vertical
13	7320.00	37.88	-3.42	34.46	54.00	19.54	124	AV	PASS	Vertical
14	7320.00	47.53	-3.42	44.11	74.00	29.89	66	PK	PASS	Vertical
15	8235.00	37.83	-1.89	35.94	54.00	18.06	209	AV	PASS	Vertical
16	8235.00	46.73	-1.89	44.84	74.00	29.16	0	PK	PASS	Vertical
17	9150.00	37.44	1.40	38.84	54.00	15.16	124	AV	PASS	Vertical
18	9150.00	46.22	1.40	47.62	74.00	26.38	216	PK	PASS	Vertical

Remark:

1. Level = Reading + FactorAntenna Factor + Cable Loss – Preamplifier Factor).

Product Name:	16-port UHF RFID Module	Product Model:	M-704
Test By:	Alan Chen	Test mode:	Tx mode
Test Frequency:	1 GHz ~ 10 GHz	Polarization:	Horizontal
Test Voltage:	AC 120/60Hz		

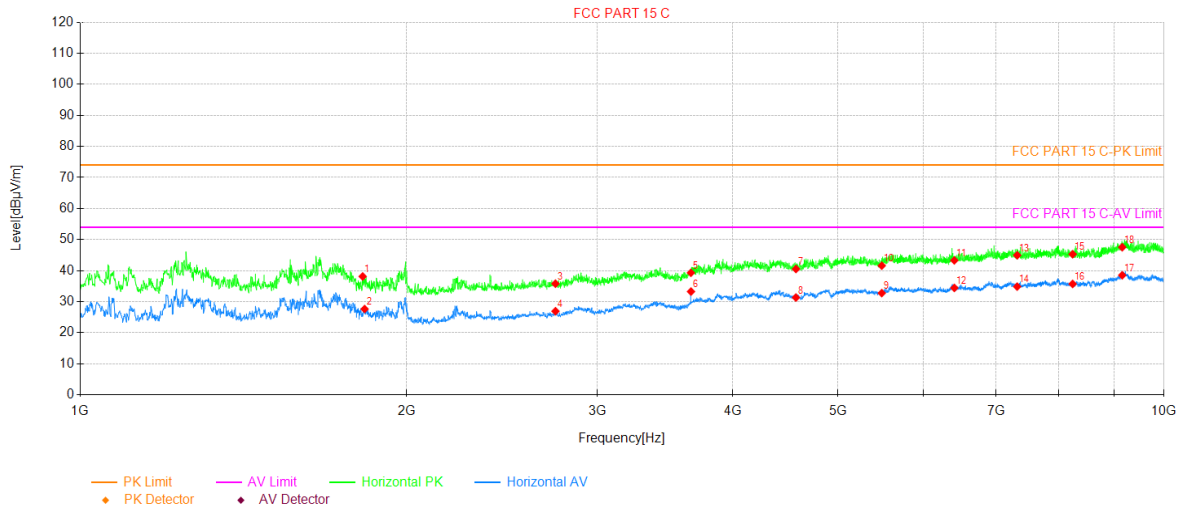

Suspected Data List										
NO.	Freq. [MHz]	Reading [dBμV]	Factor [dB/m]	Level [dBμV/m]	Limit [dBμV/m]	Margin [dB]	Angle [°]	Detector	Verdict	Polarity
1	1822.48	60.44	-22.30	38.14	74.00	35.86	109	PK	PASS	Horizontal
2	1830.00	49.92	-22.26	27.66	54.00	26.34	109	AV	PASS	Horizontal
3	2745.00	53.21	-17.40	35.81	74.00	38.19	2	PK	PASS	Horizontal
4	2745.00	44.34	-17.40	26.94	54.00	27.06	116	AV	PASS	Horizontal
5	3660.00	50.88	-11.58	39.30	74.00	34.70	267	PK	PASS	Horizontal
6	3660.96	44.85	-11.58	33.27	54.00	20.73	260	AV	PASS	Horizontal
7	4575.00	49.16	-8.63	40.53	74.00	33.47	317	PK	PASS	Horizontal
8	4575.00	39.98	-8.63	31.35	54.00	22.65	180	AV	PASS	Horizontal
9	5490.00	39.00	-6.22	32.78	54.00	21.22	28	AV	PASS	Horizontal
10	5490.00	47.82	-6.22	41.60	74.00	32.40	2	PK	PASS	Horizontal
11	6405.00	48.82	-5.51	43.31	74.00	30.69	216	PK	PASS	Horizontal
12	6405.00	39.96	-5.51	34.45	54.00	19.55	50	AV	PASS	Horizontal
13	7320.00	48.38	-3.42	44.96	74.00	29.04	288	PK	PASS	Horizontal
14	7320.00	38.29	-3.42	34.87	54.00	19.13	332	AV	PASS	Horizontal
15	8235.00	47.18	-1.89	45.29	74.00	28.71	6	PK	PASS	Horizontal
16	8235.00	37.62	-1.89	35.73	54.00	18.27	238	AV	PASS	Horizontal
17	9150.00	37.12	1.40	38.52	54.00	15.48	2	AV	PASS	Horizontal
18	9150.00	46.14	1.40	47.54	74.00	26.46	14	PK	PASS	Horizontal

Remark:

1. Level = Reading + FactorAntenna Factor + Cable Loss – Preamplifier Factor).

927.5MHz:

Product Name:	16-port UHF RFID Module	Product Model:	M-704
Test By:	Alan Chen	Test mode:	Tx mode
Test Frequency:	1 GHz ~ 10 GHz	Polarization:	Vertical
Test Voltage:	AC 120/60Hz		

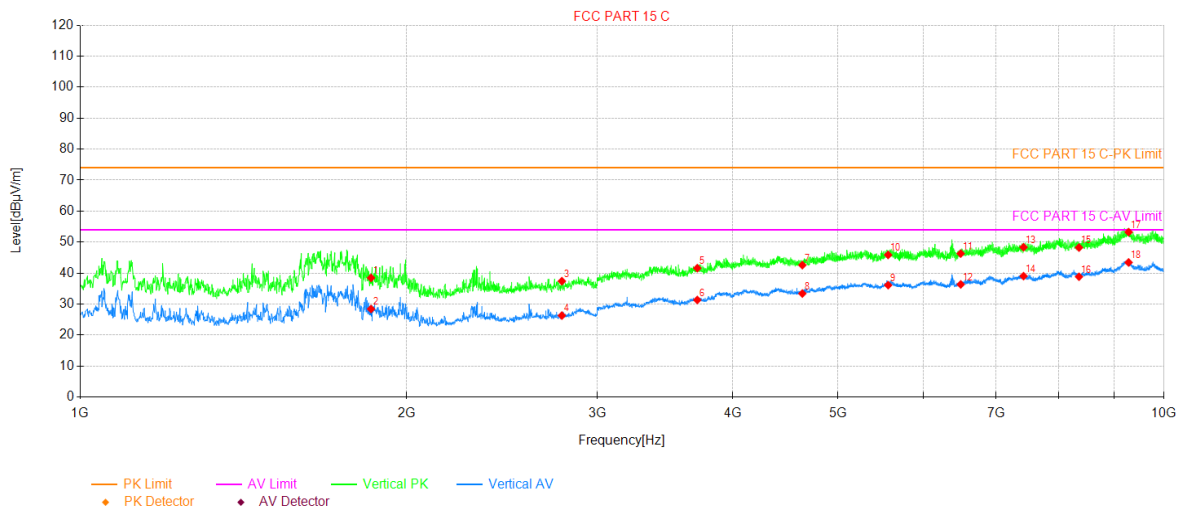

Suspected Data List										
NO.	Freq. [MHz]	Reading [dBµV]	Factor [dB/m]	Level [dBµV/m]	Limit [dBµV/m]	Margin [dB]	Angle [°]	Detector	Verdict	Polarity
1	1855.00	60.57	-22.10	38.47	74.00	35.53	177	PK	PASS	Vertical
2	1855.00	50.53	-22.10	28.43	54.00	25.57	170	AV	PASS	Vertical
3	2782.50	54.64	-17.23	37.41	74.00	36.59	301	PK	PASS	Vertical
4	2782.50	43.55	-17.23	26.32	54.00	27.68	177	AV	PASS	Vertical
5	3710.00	52.31	-10.70	41.61	74.00	32.39	225	PK	PASS	Vertical
6	3710.00	42.05	-10.70	31.35	54.00	22.65	246	AV	PASS	Vertical
7	4637.50	50.83	-8.25	42.58	74.00	31.42	211	PK	PASS	Vertical
8	4637.50	41.67	-8.25	33.42	54.00	20.58	177	AV	PASS	Vertical
9	5565.00	41.90	-5.78	36.12	54.00	17.88	177	AV	PASS	Vertical
10	5565.00	51.66	-5.78	45.88	74.00	28.12	6	PK	PASS	Vertical
11	6492.50	51.25	-4.94	46.31	74.00	27.69	260	PK	PASS	Vertical
12	6492.50	41.31	-4.94	36.37	54.00	17.63	143	AV	PASS	Vertical
13	7420.00	51.60	-3.25	48.35	74.00	25.65	218	PK	PASS	Vertical
14	7420.00	42.28	-3.25	39.03	54.00	14.97	20	AV	PASS	Vertical
15	8347.50	50.05	-1.80	48.25	74.00	25.75	95	PK	PASS	Vertical
16	8347.50	40.64	-1.80	38.84	54.00	15.16	67	AV	PASS	Vertical
17	9275.00	51.83	1.40	53.23	74.00	20.77	116	PK	PASS	Vertical
18	9275.00	42.05	1.40	43.45	54.00	10.55	116	AV	PASS	Vertical

Remark:

1. Level = Reading + FactorAntenna Factor + Cable Loss – Preamplifier Factor).

Product Name:	16-port UHF RFID Module	Product Model:	M-704
Test By:	Alan Chen	Test mode:	Tx mode
Test Frequency:	1 GHz ~ 10 GHz	Polarization:	Horizontal
Test Voltage:	AC 120/60Hz		

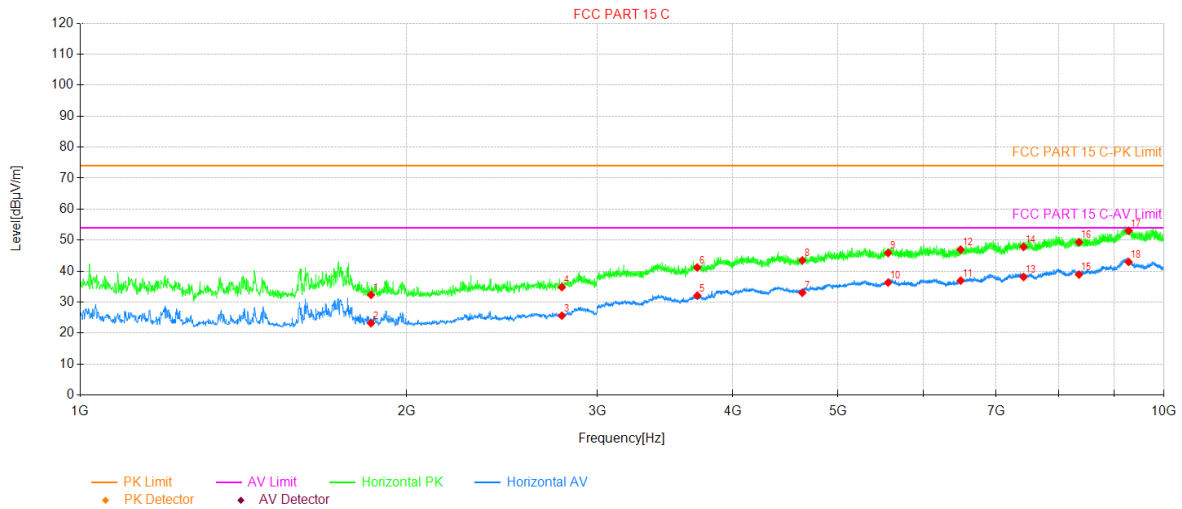

Suspected Data List

NO.	Freq. [MHz]	Reading [dBµV]	Factor [dB/m]	Level [dBµV/m]	Limit [dBµV/m]	Margin [dB]	Angle [°]	Detector	Verdict	Polarity
1	1855.00	54.44	-22.10	32.34	74.00	41.66	118	PK	PASS	Horizontal
2	1855.00	45.30	-22.10	23.20	54.00	30.80	178	AV	PASS	Horizontal
3	2782.50	42.86	-17.23	25.63	54.00	28.37	290	AV	PASS	Horizontal
4	2782.50	52.06	-17.23	34.83	74.00	39.17	319	PK	PASS	Horizontal
5	3710.00	42.81	-10.70	32.11	54.00	21.89	61	AV	PASS	Horizontal
6	3710.00	51.88	-10.70	41.18	74.00	32.82	215	PK	PASS	Horizontal
7	4637.50	41.28	-8.25	33.03	54.00	20.97	305	AV	PASS	Horizontal
8	4637.50	51.71	-8.25	43.46	74.00	30.54	170	PK	PASS	Horizontal
9	5565.00	51.62	-5.78	45.84	74.00	28.16	245	PK	PASS	Horizontal
10	5565.00	42.09	-5.78	36.31	54.00	17.69	13	AV	PASS	Horizontal
11	6492.50	41.88	-4.94	36.94	54.00	17.06	192	AV	PASS	Horizontal
12	6492.50	51.85	-4.94	46.91	74.00	27.09	96	PK	PASS	Horizontal
13	7420.00	41.36	-3.25	38.11	54.00	15.89	215	AV	PASS	Horizontal
14	7420.00	51.07	-3.25	47.82	74.00	26.18	326	PK	PASS	Horizontal
15	8347.50	40.68	-1.80	38.88	54.00	15.12	20	AV	PASS	Horizontal
16	8347.50	51.15	-1.80	49.35	74.00	24.65	6	PK	PASS	Horizontal
17	9275.00	51.61	1.40	53.01	74.00	20.99	207	PK	PASS	Horizontal
18	9275.00	41.56	1.40	42.96	54.00	11.04	111	AV	PASS	Horizontal

Remark:

1. Level = Reading + FactorAntenna Factor + Cable Loss – Preamplifier Factor).

-----End of report-----