

Electric Skateboard

Model: M

Jiangsu Kunpeng Sports Goods Co., Ltd

Table of Contents

- 1、 Index
- 2、 Introduction
- 3、 Apparatus
- 4、 Methods of Use
- 5、 The Controller and Remote Control
- 6、 Features
- 7、 Specifications
- 8、 Safety Warnings and Tips
- 9、 Troubleshooting
- 10、 Warranty
- 11、 Safe Use of Battery
- 12、 Installation Guide

Introduction

Apparatus

1. Deck

We use 8-layer of 12mm thick composite wooden boards with Kunpeng features, which make the decks flexible, durable and powerful. And in all riders' view, U-type decks will be more stable for them to use a variety of action skills.

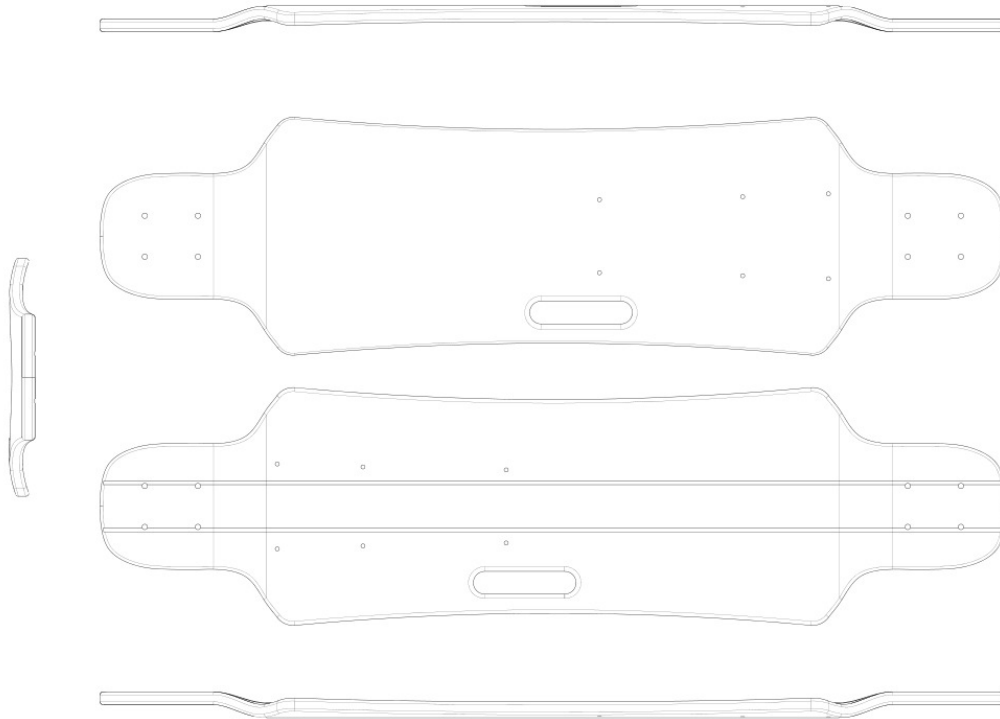

2. Battery Box

Kunpeng battery box, the low-profile multi-unit battery pack is located under the deck. For batteries, we use the latest plug-in technology. The flexible and compact battery case allows the deck to bend without affecting the sliding.

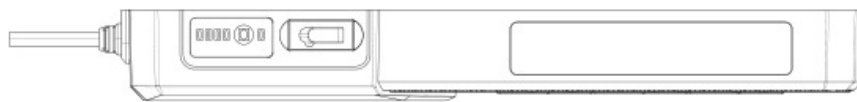
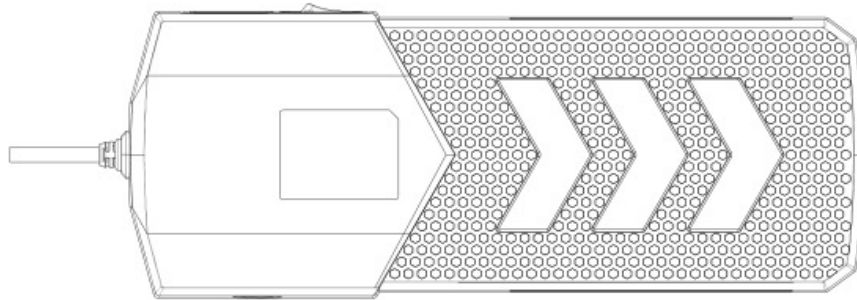
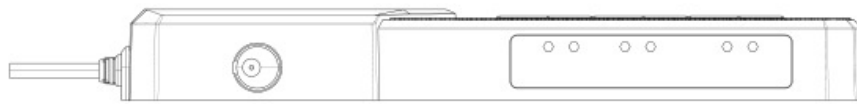

- ①. Charging port
- ②. Power switch
- ③. Power status indicator
- ④. Motor outlet

3. The Motor

By integrating the plug-in technology for the aerospace industry, the 400-watt brushless hub motor provides reliable and efficient power for electric skateboard.

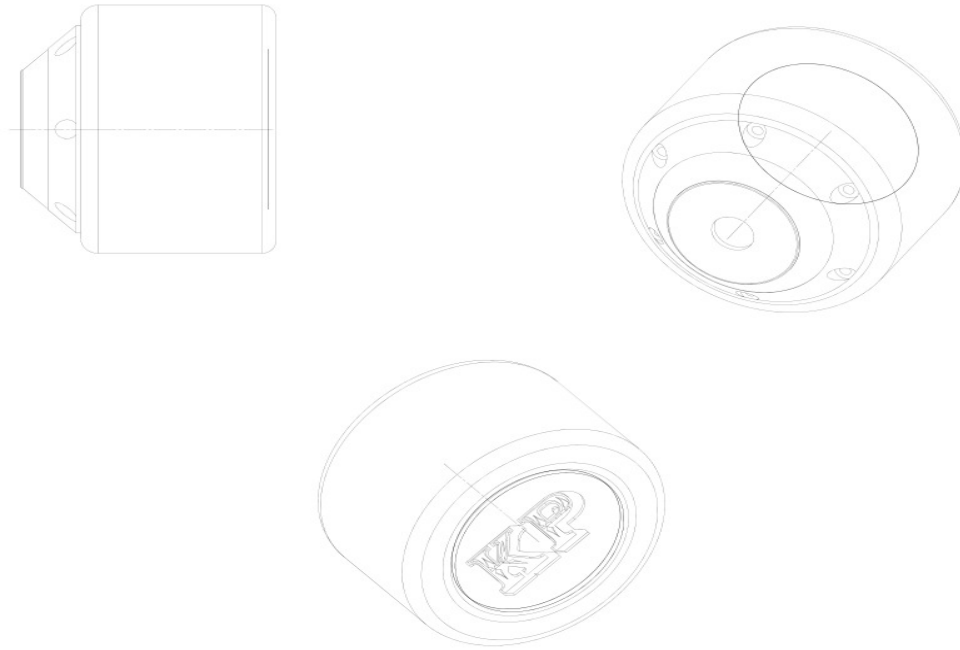

4. Wheels

We use high rebound polyurethane wheels which provides power and stability of the surface for Kunpeng skateboard and make the riders' feet feel comfortable, and we made the skateboards became a reliable urban transportation tools.

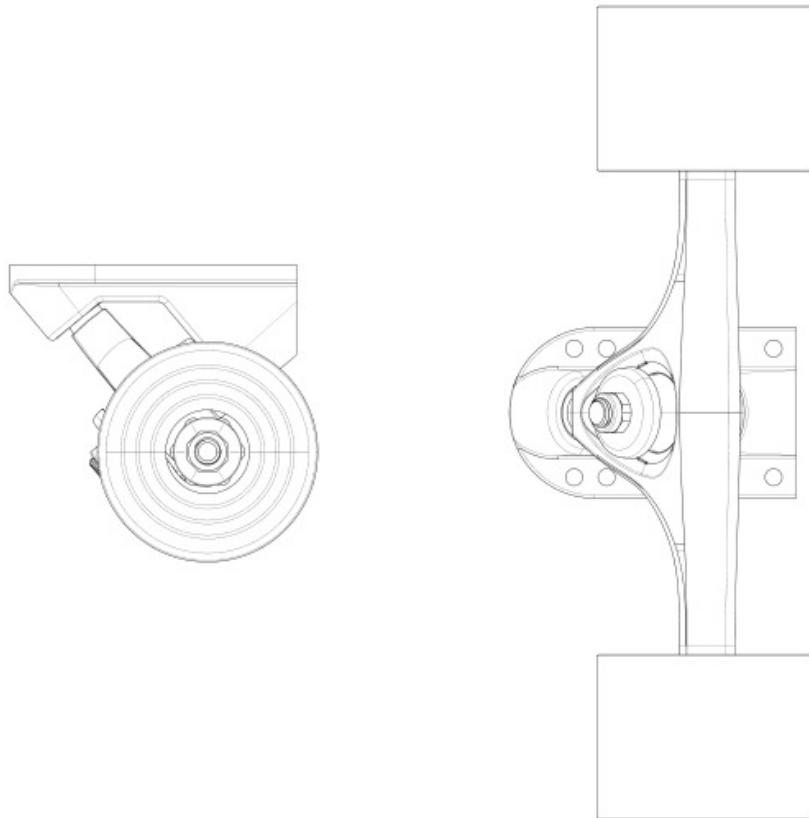

5. The Bridge

Kunpeng skateboard choose 5.5-inch and 7-inch trucks according to the deck's style and size, which make the skateboard slide stably and turn freely, and excellent stability makes higher level of stability during playing. The screw in the middle connects bridge and the base made of the highest grade material, the steering performance and flexibility of the skateboard can be changed by adjusting the top nut.

6. The Remote Control

A sleek and compact wireless controller is one of the key features of Kunpeng Skateboard, and you can intuitively control the skateboard's movement by controlling the buttons of accelerator / brake / forward /

backward / fast / slow speed.

As the picture shows :

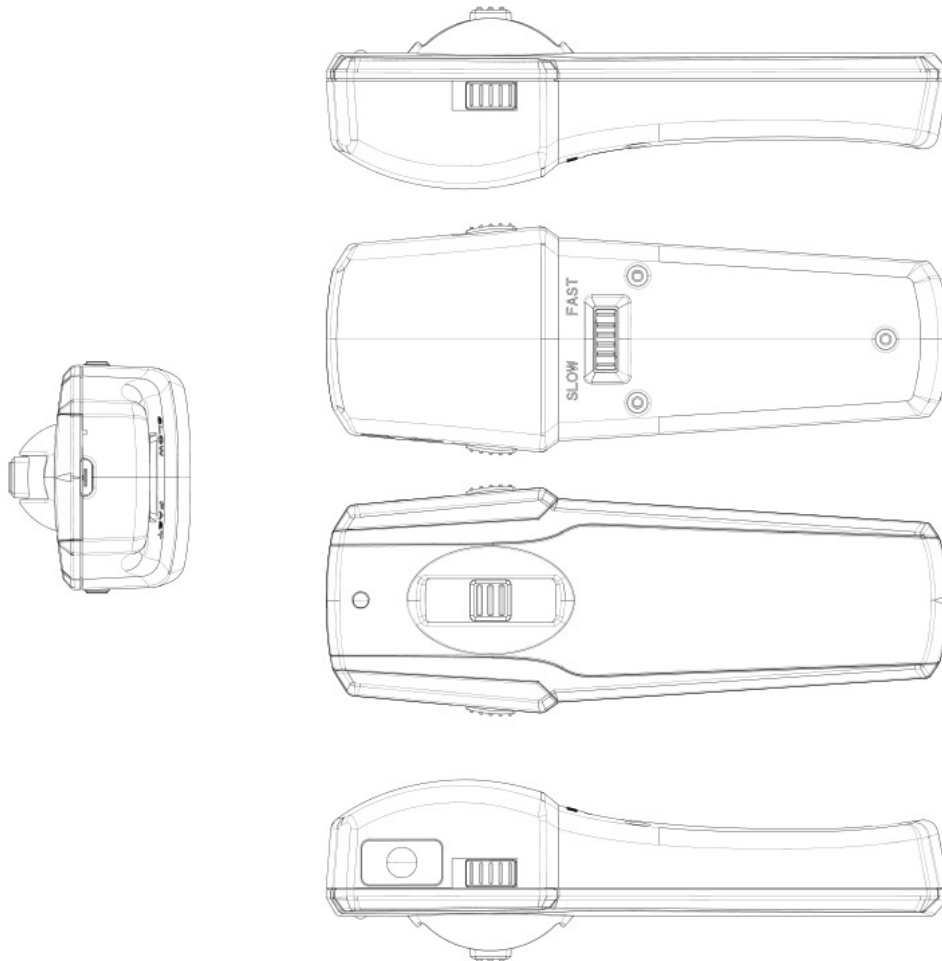

Remote control has one putter, three switches, one contact, and one charging port. The putter is used to control the acceleration, push forward is speed-up, backward push is the brake. The two switches on the both sides of the transmitter are the remote control power switch and reversing switch; reversing switch means that skateboard can move forward or backward by toggling the switch. There is also a contact by the remote control power switch, which is the frequency switch, if your skateboard

equipped with flashing lights, then it can also use as flashing lights switch. The switch on the back of the controller is the gear switch, which includes fast and slow gear, slow gear only has 50% of speed compare with fast gear, we recommend the beginners use slow gear, and riders may consider using the fast gear after their adaptation. The last is the charging port, our remote control charging port matches Micro-USB cable, so don't worry that you can't find the place to charge.

7. Skateboarding Tools

To ensure the integrity of the performance of the skateboard, you must regularly clean the dust on skateboard and check the tightness of the screws. Each skateboard equipped with a set of professional tools; you can easily disassemble each part of the skateboard. It gives riders a better control of skateboard's performance, which deployed to the highest performance for riders.

8. Charger

Each of our skateboard equipped with a USB remote charging cable and a skateboard charger. The USB cable can be connected to any ordinary mobile phone charger, you can start charging once connected with transmitter while keep the remote control switch open during charging, the transmitter lights will flash, and stops when charging is done. It is a

smart charger, the skateboard will display a red light when charging, and the green light for full power to stop charging, so as to prevent over charge phenomenon for the battery, and skateboard takes 1-2 hours to fully charge.

Methods of Use

Controller and remote control

1. You can clearly see the remote control has a putter, three switches, a contact and a charging port. We can also see a switch, a charge port and a row of power indicators on the battery box.
2. First we have to make sure the remote control switch and battery box switches are turned off.
3. Push the steering gear to forward position, and push the speed gear to slow position.
4. Open the remote control switch, you will see the remote control light on, then it shows the transmitter has been turned on.
5. Open the battery box switch, and battery indicator light will be on, so will the signal light.
6. Make the remote control get near the battery, and take a long press on the transmitter contacts, until you see the transmitter light and the battery box signal light flash at the same time, then you can disconnect.

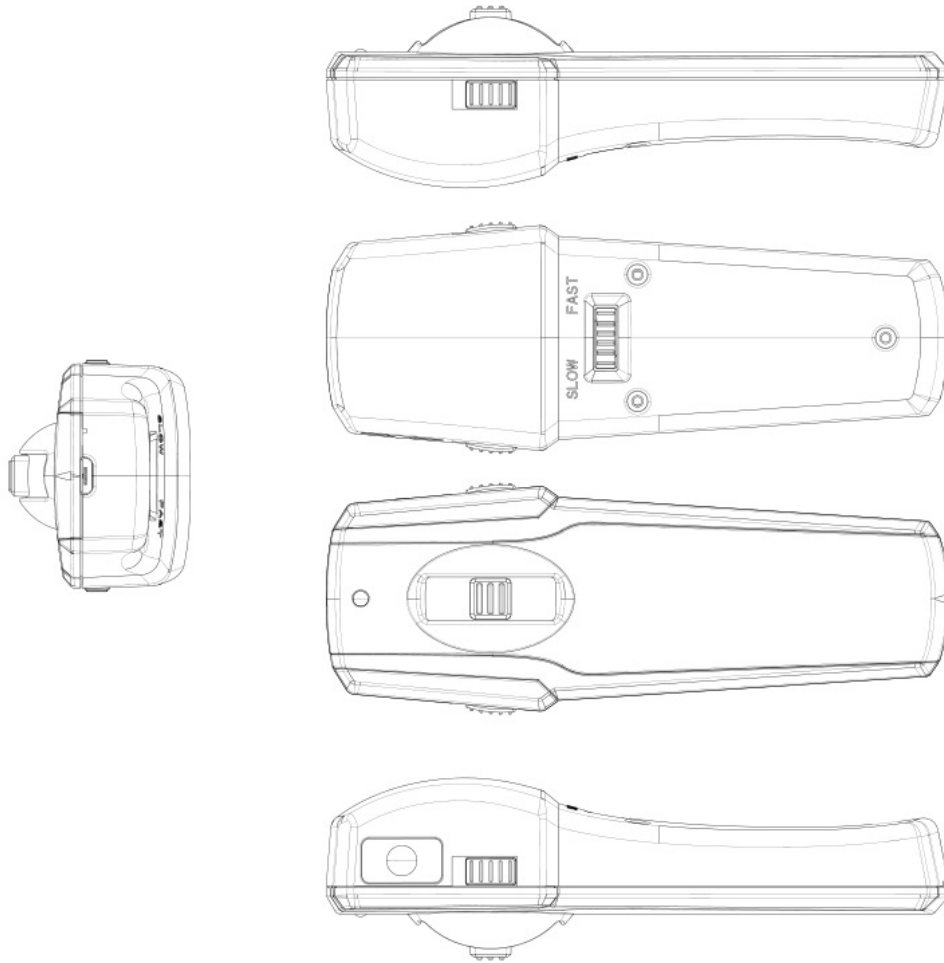

7. You will see the battery box lights flashing fast, which indicates the frequency is completed.

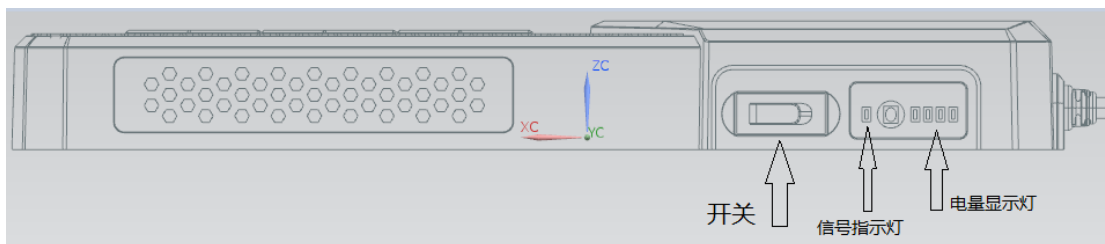
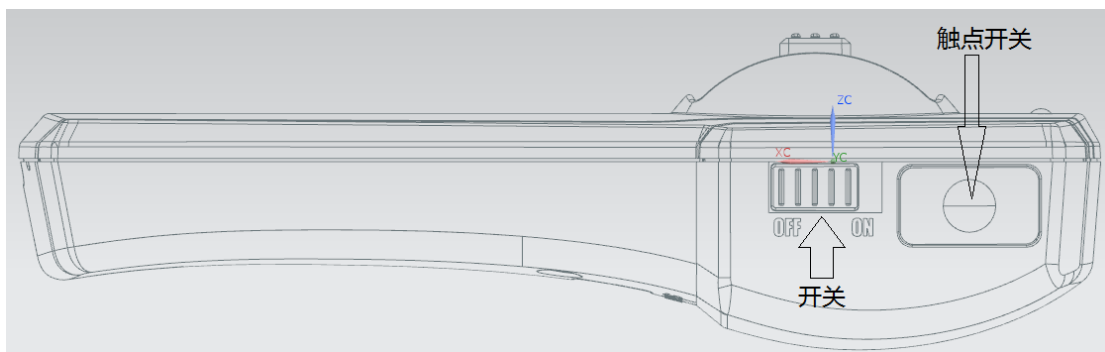

Features

1. Two Speed Modes

Slow mode: suitable for beginners, the rate is controlled at 65% of full speed, and makes the riding-learning more relaxed and safe.

Fast mode: suitable for skilled and experienced skateboarding players, it's quick with strong climbing power.

2. KP skateboard suitable for different user levels

Children: slow 5 ~ 6km/h, fast 8km/h, Single drive

Adolescent models: slow 10km/h, fast 16km/h, single drive

Young professional models: slow 18km/h, fast 25km/h, dual drive

Adult section: slow 18km/h, fast 25km/h, single drive

Adult professional section: slow 20km/h, fast 28km/h, dual drive

3. KP skateboard batteries are from Samsung original lithium batteries, which can complete the fast charge, and the charging time is 1 - 2 hours, so it's necessary to use standard 1A current. The charging time for the remote control is 30 minutes and it can charge by any Micro-USB cable.

4. KP skateboard are using the most advanced power recovery system, which means when you are sliding in the non-power glide situation; the generated electricity will be recycled into the battery, thereby enhancing

the driving life of the skateboard.

5. One KP skateboard is only 4.8KG, this weight allows more professional riders fall in love with this product. Riders can easily do their actions with it.

Specifications

1. Performance

The rider's maximum weight: 125 kg

Maximum mileage: 15km

Highest speed mode: 18.6 miles / 30 km / h

Minimum low speed mode: 3.1 miles / 5 km / h

2. Skateboard

Deck Material: Canadian maple

Deck size: 915 * 240 mm

Wheels material : Polyurethane

Wheels size: 75 mm diameter / 55 mm wide

Battery Type: Lithium Ion

Battery capacity: 2.2AH

Number of batteries: 7

Battery charging time: 1-2 hours

Engine Type: External rotor brushless DC motor

Motor power: 400W

Transmission mode: wheel direct drive

Board weight: 10.6 lb / 4.8 kg

3. Charger

Maximum input: AC100-240V / 50-60HZ / 1.5A

Rated output: DC 29.4V / 1A

Charging indicator: Charge red / full green

4. Remote Control

Material: ABS plastic

Size: 123 * 44 * 33 mm

Weight: 60 grams

Battery type: lithium battery

Battery capacity: 200mah

Battery charging time: 30 minutes

Wireless connection: 2.4GHZ

With Vibration: affirmative

Security warnings and prompts

Before riding the KP skateboard, it is highly recommended to read and follow all the hints, tips and warnings listed as below. It can help to reduce the inherent risk. When riding an own skateboard, if it exceeds your ability or KP skateboard get through obstacles or other unsuitable surfaces, this can cause a collision and scratch the chassis which will result in serious or fatal injury or damage to your skateboard.

For New Skateboard Riders

First time user of KP skateboard. The rider shall use low-speed mode. An experienced rider shall practice in a spacious, non-traffic area during the 1st use. Experienced rider should assist with more experienced riders. Do not let new rider use KP Skateboard control without read this guide. First time rider shall ask help from experienced riders or other people's till KP skateboard is learned.

Summary for riders

KP skateboard designed for users at aged 10 and above. They intended for riders weighing 125 kg / 276 lb or less. KP skateboard can not use for carrying goods. KP skateboard designed for rider with good health. You

must not ride if you feel uncomfortable. You must be vigilant to travel safely as the same as use other personal electric transportation tools. KP skateboard can not carry any non - rider, and do not play by getting several boards together. You shall not hold the child to ride and do not ride after drinking or taking drugs. Do not ride if you can not follow the instructions and warnings in this guide.

Troubleshooting

What should I do if my skateboard doesn't work

1.1 Check if the electric skateboard is switched on : When the switch turned on you should see the battery indicator and the signal indicator.

1.2 Check whether the remote control is activated: When the transmitter turned on, the indicator lights.

1.3 If both of the skateboard and the transmitter are on, if the signal indicator on the battery box is not flashing rapidly, which means that the skateboard and the remote controller are not connected, just activate the frequency mode.

1.4 If the transmitter and skateboard are linked, and the battery box is also in the fast flashing lights state, then check if the battery indicator is in one grid of electricity state, if so it means your battery power is running out, you need to charge.

1.5 During the riding, if it is clear that the speed has slowed down, and the intensity is insufficient, it shows the skateboard power is low, and it needs to charge, now the remote control needs to charge with battery box.

Warranty

①. Skateboard parts

1. Regular use (non-human or by external damage)

1. Deck: free to replace a new one within eight months

3. Truck fracture: free replacement within one year

4. Bearings and wheels are consumable and are not covered under warranty, depending on how they used and the road condition.

②. Control system and motor

1. Regular use (non-human disassembly, visible impact, high-altitude fall, water and other external factors damage) results in failure.

2. Remote control and monitoring system: damage within eight months, maintenance will be provided, the control system and remote control will replace with new ones in critical condition.

3. Motor: failure within eight months support will be provided; there will be the replacement of the new engine in a critical condition.

③. Customers need to know: for bulk production, we will distribute 0.3% of the main control board and remote control board, and provide fault repair training; there are maintenance seals in the central control part and the motor part. Maintenance will be refused if customers tore the repair sealing paste privately or remove the parts themselves. The main control

board and the motor will be used as connectors to facilitate replacement and maintenance.

Safe use of battery

If the batteries are defective or used improperly may cause lithium batteries explosion, which will lead to fire. Therefore, it is recommended that you read the following description carefully :

Please carefully place the battery, especially the protective seal and sleeve, to ensure that they are not damaged and leaked. If you have any questions or need a chemical waste disposal facility for the battery, please contact us immediately.

The batteries need to store in a safe and dry place, keeping the batteries away from metal objects.

The batteries temperature shall not exceed 100 °C.

You can only use the official charger, which specially designed for lithium battery.

When charging the battery, please keep the charger away from highly flammable materials or products.

The charger may become hot during charging; please be aware it is a normal phenomenon.

If you do not intend to use the batteries within 6 months, you must fully charge the batteries.

This equipment has been tested and found to comply with the limits for a Class B digital device, pursuant to part 15 of the FCC Rules. These limits are designed to provide reasonable protection against harmful interference in a residential installation. This equipment generates, uses and can radiate radio frequency energy and, if not installed and used in accordance with the instructions, may cause harmful interference to radio communications. However, there is no guarantee that interference will not occur in a particular installation. If this equipment does cause harmful interference to radio or television reception, which can be determined by turning the equipment off and on, the user is encouraged to try to correct the interference by one or more of the following measures:

- Reorient or relocate the receiving antenna.
- Increase the separation between the equipment and receiver.
- Connect the equipment into an outlet on a circuit different from that to which the receiver is connected.
- Consult the dealer or an experienced radio/TV technician for help.

Caution: Any changes or modifications to this device not explicitly approved by manufacturer could void your authority to operate this equipment.

This device complies with part 15 of the FCC Rules. Operation is subject to the following two conditions: (1) This device may not cause harmful interference, and (2) this device must accept any interference received, including interference that may cause undesired operation.

The device has been evaluated to meet general RF exposure requirement.