

APPLICATION CERTIFICATION FCC Part 15C
On Behalf of
Shenzhen IWOWN Technology Co., Ltd.

iWOWNfit Fitness
Model No.: i7A

FCC ID: 2AKPH-I7A

Prepared for : Shenzhen IWOWN Technology Co., Ltd.
Address : 10A, Block C, Tongfang Information Harbor, No. 11 Langshan
Road, Nanshan District, Shenzhen, China

Prepared by : Shenzhen Accurate Technology Co., Ltd.
Address : 1/F., Building A, Changyuan New Material Port, Science & Industry
Park, Nanshan District, Shenzhen, Guangdong, P.R. China

Tel: (0755) 26503290

Fax: (0755) 26503396

Report No. : ATE20181665
Date of Test : September 12-14, 2018
Date of Report : September 18, 2018

TABLE OF CONTENTS

Description	Page
Test Report Certification	
1. GENERAL INFORMATION	5
1.1. Description of Device (EUT).....	5
1.2. Carrier Frequency of Channels.....	5
1.3. Special Accessory and Auxiliary Equipment	6
1.4. Description of Test Facility	6
1.5. Measurement Uncertainty.....	6
2. MEASURING DEVICE AND TEST EQUIPMENT	7
3. OPERATION OF EUT DURING TESTING	8
3.1. Operating Mode.....	8
3.2. Configuration and peripherals	8
4. TEST PROCEDURES AND RESULTS	9
5. POWER LINE CONDUCTED MEASUREMENT	10
5.1. Block Diagram of Test Setup.....	10
5.2. Power Line Conducted Emission Measurement Limits.....	11
5.3. Configuration of EUT on Measurement	11
5.4. Operating Condition of EUT	11
5.5. Test Procedure	11
5.6. Data Sample.....	12
5.7. Power Line Conducted Emission Measurement Results	12
6. 6DB BANDWIDTH MEASUREMENT.....	15
6.1. Block Diagram of Test Setup.....	15
6.2. The Requirement For Section 15.247(a)(2).....	15
6.3. EUT Configuration on Measurement	15
6.4. Operating Condition of EUT	15
6.5. Test Procedure	15
6.6. Test Result	16
7. MAXIMUM PEAK OUTPUT POWER	18
7.1. Block Diagram of Test Setup.....	18
7.2. The Requirement For Section 15.247(b)(3).....	18
7.3. EUT Configuration on Measurement	18
7.4. Operating Condition of EUT	18
7.5. Test Procedure	18
7.6. Test Result	19
8. POWER SPECTRAL DENSITY MEASUREMENT.....	21
8.1. Block Diagram of Test Setup.....	21
8.2. The Requirement For Section 15.247(e).....	21
8.3. EUT Configuration on Measurement	21
8.4. Operating Condition of EUT	21
8.5. Test Procedure	21
8.6. Test Result	22
9. BAND EDGE COMPLIANCE TEST	24
9.1. Block Diagram of Test Setup.....	24
9.2. The Requirement For Section 15.247(d)	24
9.3. EUT Configuration on Measurement	24

9.4.	Operating Condition of EUT	24
9.5.	Test Procedure	25
9.6.	Test Result	25
10.	RADIATED SPURIOUS EMISSION TEST	31
10.1.	Block Diagram of Test Setup.....	31
10.2.	The Limit For Section 15.247(d)	32
10.3.	Restricted bands of operation	33
10.4.	Configuration of EUT on Measurement	33
10.5.	Operating Condition of EUT	34
10.6.	Test Procedure	34
10.7.	Data Sample.....	35
10.8.	The Field Strength of Radiation Emission Measurement Results	35
11.	ANTENNA REQUIREMENT.....	48
11.1.	The Requirement	48
11.2.	Antenna Construction	48

Test Report Certification

Applicant : Shenzhen IWOWN Technology Co., Ltd.
Manufacturer : Shenzhen IWOWN Technology Co., Ltd.
EUT Description : iWOWNfit Fitness
Model No. : i7A
Trade Name : iWOWNfit

Measurement Procedure Used:

FCC Rules and Regulations Part 15 Subpart C Section 15.247
ANSI C63.10: 2013

The EUT was tested according to DTS test procedure of Apr 05, 2017 KDB558074 D01 DTS Meas Guidance v04 for compliance to FCC 47CFR 15.247 requirements

The device described above is tested by Shenzhen Accurate Technology Co., Ltd. to determine the maximum emission levels emanating from the device. The maximum emission levels are compared to the FCC Part 15 Subpart C Section 15.247 limits. The measurement results are contained in this test report and Shenzhen Accurate Technology Co., Ltd. is assumed full responsibility for the accuracy and completeness of these measurements. Also, this report shows that the Equipment Under Test (EUT) is to be technically compliant with the FCC requirements. This report applies to above tested sample only. This report shall not be reproduced in part without written approval of Shenzhen Accurate Technology Co., Ltd.

Date of Test : September 12-14, 2018
Date of Report : September 18, 2018

Bob Wang

Test Engineer : _____
(Bob Wang, Engineer)

Prepared by : _____
(Bob Wang, Engineer)

Bob Wang

Approved & Authorized Signer : _____
(Sean Liu, Manager)

Sean Liu

1. GENERAL INFORMATION

1.1. Description of Device (EUT)

EUT : iWOWNfit Fitness

Model Number : i7A

Bluetooth version : V4.2 BLE

Frequency Range : 2402MHz-2480MHz

Number of Channels : 40

Antenna Gain : 1.72dBi

Antenna type : Ceramic antenna

Power Supply : DC 3.7V

Modulation mode : GFSK

Hardware version : V1.3

Software version : V1.0.0.15

Applicant : Shenzhen IWOWN Technology Co., Ltd.
 Address : 10A, Block C, Tongfang Information Harbor, No. 11
 Langshan Road, Nanshan District, Shenzhen, China

Manufacturer : Shenzhen IWOWN Technology Co., Ltd.
 Address : 10A, Block C, Tongfang Information Harbor, No. 11
 Langshan Road, Nanshan District, Shenzhen, China

1.2. Carrier Frequency of Channels

Channel	Frequency (MHz)	Channel	Frequency (MHz)	Channel	Frequency (MHz)	Channel	Frequency (MHz)
0	2402	10	2422	20	2442	30	2462
1	2404	11	2424	21	2444	31	2464
2	2406	12	2426	22	2446	32	2466
3	2408	13	2428	23	2448	33	2468
4	2410	14	2430	24	2450	34	2470
5	2412	15	2432	25	2452	35	2472
6	2414	16	2434	26	2454	36	2474
7	2416	17	2436	27	2456	37	2476
8	2418	18	2438	28	2458	38	2478
9	2420	19	2440	29	2460	39	2480

1.3.Special Accessory and Auxiliary Equipment

AC/DC Power Adapter (provided by laboratory)	:	Model:BEK-QC-001 INPUT: 120V~60Hz OUTPUT:5V/1A
---	---	--

1.4.Description of Test Facility

EMC Lab	<p>: Recognition of accreditation by Federal Communications Commission (FCC) The Designation Number is CN1189 The Registration Number is 708358</p> <p>Listed by Innovation, Science and Economic Development Canada (ISED) The Registration Number is 5077A-2</p> <p>Accredited by China National Accreditation Service for Conformity Assessment (CNAS) The Registration Number is CNAS L3193</p> <p>Accredited by American Association for Laboratory Accreditation (A2LA) The Certificate Number is 4297.01</p>
Name of Firm	: Shenzhen Accurate Technology Co., Ltd.
Site Location	: 1/F., Building A, Changyuan New Material Port, Science & Industry Park, Nanshan District, Shenzhen, Guangdong, P.R. China

1.5.Measurement Uncertainty

Conducted Emission Expanded Uncertainty	= 2.23dB, k=2
Radiated emission expanded uncertainty (9kHz-30MHz)	= 3.08dB, k=2
Radiated emission expanded uncertainty (30MHz-1000MHz)	= 4.42dB, k=2
Radiated emission expanded uncertainty (Above 1GHz)	= 4.06dB, k=2

2. MEASURING DEVICE AND TEST EQUIPMENT

Table 1: List of Test and Measurement Equipment

Kind of equipment	Manufacturer	Type	S/N	Calibrated dates	Calibrated until
EMI Test Receiver	Rohde&Schwarz	ESCS30	100307	Jan. 06, 2018	1 Year
EMI Test Receiver	Rohde&Schwarz	ESPI3	101526/003	Jan. 06, 2018	1 Year
Spectrum Analyzer	Agilent	E7405A	MY45115511	Jan. 06, 2018	1 Year
Pre-Amplifier	Rohde&Schwarz	CBLU1183540-01	3791	Jan. 06, 2018	1 Year
Loop Antenna	Schwarzbeck	FMZB1516	1516131	Jan. 06, 2018	1 Year
Bilog Antenna	Schwarzbeck	VULB9163	9163-323	Jan. 06, 2018	1 Year
Horn Antenna	Schwarzbeck	BBHA9120D	9120D-655	Jan. 06, 2018	1 Year
Horn Antenna	Schwarzbeck	BBHA9170	9170-359	Jan. 06, 2018	1 Year
LISN	Rohde&Schwarz	ESH3-Z5	100305	Jan. 06, 2018	1 Year
LISN	Schwarzbeck	NSLK8126	8126431	Jan. 06, 2018	1 Year
Highpass Filter	Wainwright Instruments	WHKX3.6/18G-10S	N/A	Jan. 06, 2018	1 Year
Band Reject Filter	Wainwright Instruments	WRCG2400/2485-2375/2510-60/11SS	N/A	Jan. 06, 2018	1 Year
RF COAXIAL CABLE	SUHNER	N-5m(Frequency range:9KHz-26.5GHz)	NO.3	Jan. 06, 2018	1 Year
RF COAXIAL CABLE	SUHNER	N-5m(Frequency range:9KHz-26.5GHz)	NO.4	Jan. 06, 2018	1 Year
RF COAXIAL CABLE	SUHNER	N-1m(Frequency range:9KHz-26.5GHz)	NO.5	Jan. 06, 2018	1 Year
RF COAXIAL CABLE	SUHNER	N-1m(Frequency range:9KHz-26.5GHz)	NO.6	Jan. 06, 2018	1 Year
Temporary antenna connector	NTGS	14AE	N/A	April 19, 2018	N/A

Note: The temporary antenna connector is soldered on the PCB board in order to perform conducted tests and this temporary antenna connector is listed in the equipment list.

3. OPERATION OF EUT DURING TESTING

3.1. Operating Mode

The mode is used: **BLE Transmitting mode**

Low Channel: 2402MHz

Middle Channel: 2440MHz

High Channel: 2480MHz

Note: The equipment under test (EUT) was tested under fully-charged battery.

The Bluetooth has been tested under continuous transmission mode.

Its duty cycle setting is greater than 98%.

3.2. Configuration and peripherals

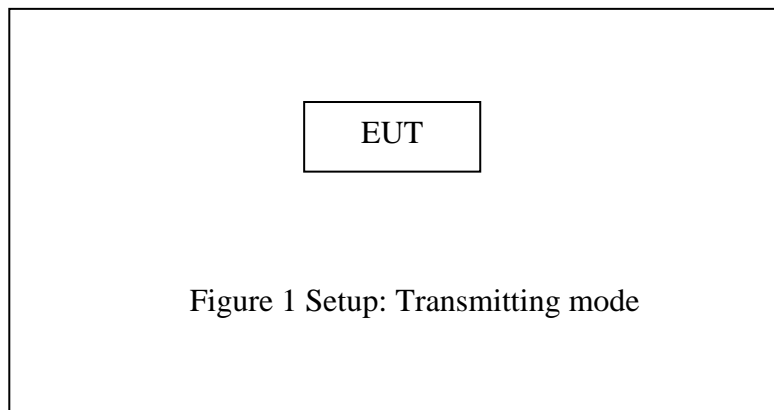

4. TEST PROCEDURES AND RESULTS

FCC Rules	Description of Test	Result
Section 15.247(a)(2)	6dB Bandwidth Test	Compliant
Section 15.247(e)	Power Spectral Density Test	Compliant
Section 15.247(b)(3)	Maximum Peak Output Power Test	Compliant
Section 15.247(d)	Band Edge Compliance Test	Compliant
Section 15.247(d) Section 15.209	Radiated Spurious Emission Test	Compliant
Section 15.207	AC Power Line Conducted Emission Test	Compliant
Section 15.203	Antenna Requirement	Compliant

5. POWER LINE CONDUCTED MEASUREMENT

5.1. Block Diagram of Test Setup

5.1.1. Block diagram of connection between the EUT and simulators

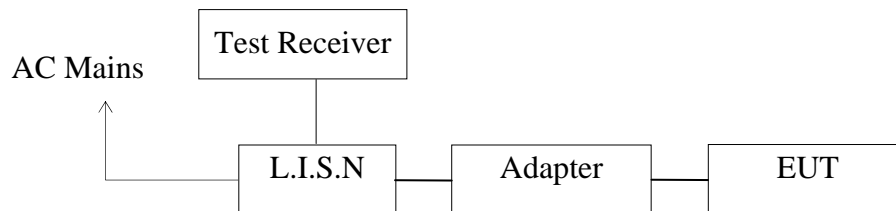

(EUT: iWOWNfit Fitness)

5.1.2. Test System Setup

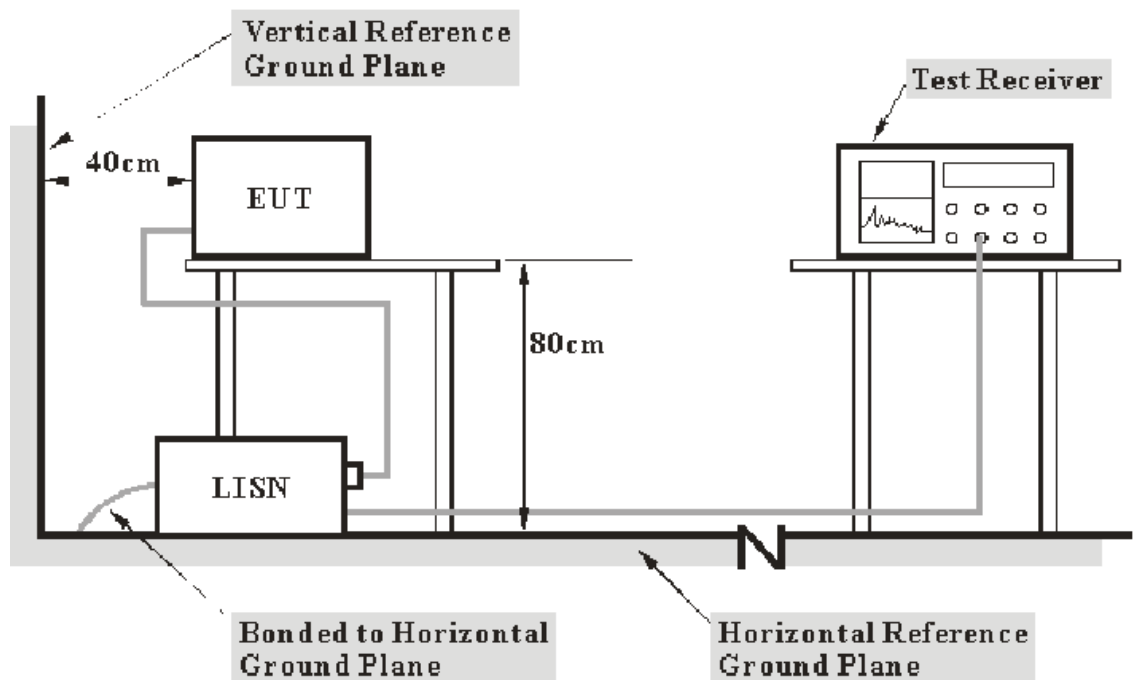

- Note:**
1. Support units were connected to second LISN.
 2. Both of LISNs (AMN) 80 cm from EUT and at the least 80 cm from other units and other metal planes support units.

5.2. Power Line Conducted Emission Measurement Limits

Frequency (MHz)	Limit dB(μV)	
	Quasi-peak Level	Average Level
0.15 - 0.50	66.0 – 56.0 *	56.0 – 46.0 *
0.50 - 5.00	56.0	46.0
5.00 - 30.00	60.0	50.0

NOTE1: The lower limit shall apply at the transition frequencies.
 NOTE2: The limit decreases linearly with the logarithm of the frequency in the range 0.15MHz to 0.50MHz.

5.3. Configuration of EUT on Measurement

The equipments are installed on Power Line Conducted Emission Measurement to meet the commission requirement and operating regulations in a manner, which tends to maximize its emission characteristics in a normal application.

5.4. Operating Condition of EUT

5.4.1. Setup the EUT and simulator as shown as Section 5.1.

5.4.2. Turn on the power of all equipment.

5.4.3. Let the EUT work in test mode and measure it.

5.5. Test Procedure

The EUT is put on the plane 0.8 m high above the ground by insulating support and is connected to the power mains through a line impedance stabilization network (L.I.S.N.). This provides a 50ohm coupling impedance for the EUT system. Please refer the block diagram of the test setup and photographs. Both sides of AC lines are checked to find out the maximum conducted emission. In order to find the maximum emission levels, the relative positions of equipment and all of the interface cables shall be changed according to ANSI C63.10: 2013 on Conducted Emission Measurement.

The bandwidth of test receiver (R & S ESCS30) is set at 9kHz.

The frequency range from 150kHz to 30MHz is checked.

5.6.Data Sample

Frequency (MHz)	Transducer value (dB)	QuasiPeak Level (dBμV)	Average Level (dBμV)	QuasiPeak Limit (dBμV)	Average Limit (dBμV)	QuasiPeak Margin (dB)	Average Margin (dB)	Remark (Pass/Fail)
X.XX	11.1	41.8	32.0	56.0	46.0	14.2	14.0	Pass

Frequency(MHz) = Emission frequency in MHz

Transducer value(dB) = Insertion loss of LISN + Cable Loss

Level(dBμV) = Quasi-peak Reading/Average Reading + Transducer value

Limit (dBμV) = Limit stated in standard

Margin = Limit (dBμV) - Level (dBμV)

Calculation Formula:

Margin = Limit (dBμV) - Level (dBμV)

5.7.Power Line Conducted Emission Measurement Results

Pass.

Test Lab: Shielding room

Test Engineer: Bob

The frequency range from 150kHz to 30MHz is checked.

Maximizing procedure was performed on the six (6) highest emissions of the EUT. Emissions attenuated more than 20 dB below the permissible value are not reported.

All data was recorded in the Quasi-peak and average detection mode.

The spectral diagrams are attached as below.

ACCURATE TECHNOLOGY CO., LTD

CONDUCTED EMISSION STANDARD FCC PART 15B

EUT: iWOWNfit Fitness M/N:i7A
 Manufacturer: Shenzhen IWOWN Technology Co.,Ltd
 Operating Condition: Charging and Operating
 Test Site: 2#Shielding Room
 Operator: Bob
 Test Specification: L 120V/60Hz
 Comment: Report NO.:ATE20181665
 Start of Test: 2018-9-12 / 15:30:50

SCAN TABLE: "V 150K-30MHz fin"

Short Description: _SUB_STD_VTERM2 1.70
 Start Stop Step Detector Meas. IF Transducer
 Frequency Frequency Width Time Bandw.
 150.0 kHz 30.0 MHz 4.5 kHz QuasiPeak 1.0 s 9 kHz NSLK8126 2008
 Average

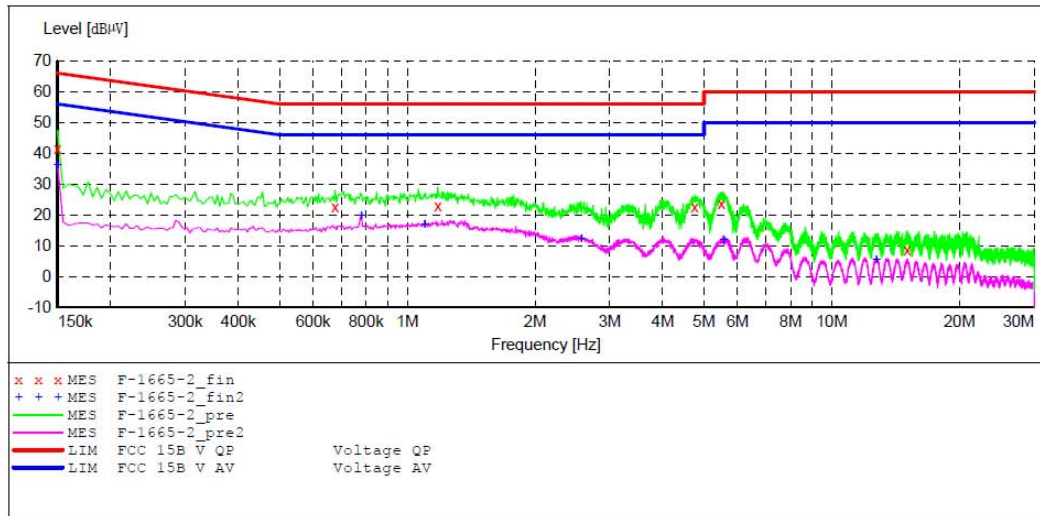

MEASUREMENT RESULT: "F-1665-2_fin"

2018-9-12 15:33

Frequency MHz	Level dBµV	Transd dB	Limit dBµV	Margin dB	Detector	Line	PE
0.150000	41.50	10.8	66	24.5	QP	L1	GND
0.676500	22.70	11.1	56	33.3	QP	L1	GND
1.180500	23.00	11.2	56	33.0	QP	L1	GND
4.753500	22.50	11.4	56	33.5	QP	L1	GND
5.491500	23.90	11.5	60	36.1	QP	L1	GND
15.058500	8.60	11.6	60	51.4	QP	L1	GND

MEASUREMENT RESULT: "F-1665-2_fin2"

2018-9-12 15:33

Frequency MHz	Level dBµV	Transd dB	Limit dBµV	Margin dB	Detector	Line	PE
0.150000	36.20	10.8	56	19.8	AV	L1	GND
0.780000	19.80	11.1	46	26.2	AV	L1	GND
1.099500	16.90	11.1	46	29.1	AV	L1	GND
2.571000	12.20	11.3	46	33.8	AV	L1	GND
5.563500	12.00	11.5	50	38.0	AV	L1	GND
12.750000	5.60	11.6	50	44.4	AV	L1	GND

ACCURATE TECHNOLOGY CO., LTD

CONDUCTED EMISSION STANDARD FCC PART 15B

EUT: iWOWNfit Fitness M/N:i7A
 Manufacturer: Shenzhen IWOWN Technology Co.,Ltd
 Operating Condition: Charging and Operating
 Test Site: 2#Shielding Room
 Operator: Bob
 Test Specification: N 120V/60Hz
 Comment: Report NO.:ATE20181665
 Start of Test: 2018-9-12 / 15:27:22

SCAN TABLE: "V 150K-30MHz fin"

Start	Stop	Step	Detector	Meas. Time	IF Bandw.	Transducer
150.0 kHz	30.0 MHz	4.5 kHz	QuasiPeak	1.0 s	9 kHz	NSLK8126 2008
Average						

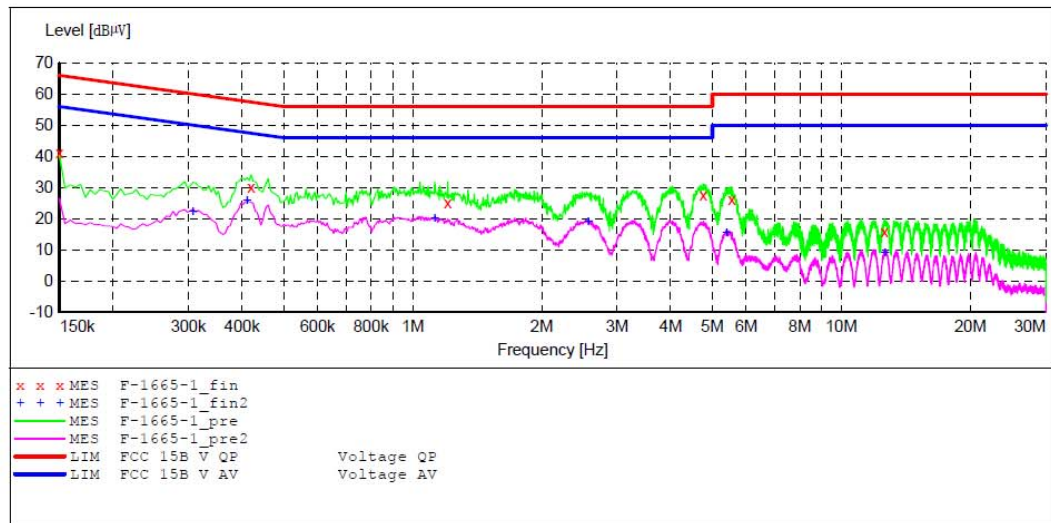

MEASUREMENT RESULT: "F-1665-1_fin"

2018-9-12 15:30

Frequency MHz	Level dBµV	Transd dB	Limit dBµV	Margin dB	Detector	Line	PE
0.150000	41.20	10.8	66	24.8	QP	N	GND
0.420000	30.10	11.0	57	27.3	QP	N	GND
1.207500	25.00	11.2	56	31.0	QP	N	GND
4.758000	27.60	11.4	56	28.4	QP	N	GND
5.550000	26.30	11.5	60	33.7	QP	N	GND
12.624000	15.90	11.6	60	44.1	QP	N	GND

MEASUREMENT RESULT: "F-1665-1_fin2"

2018-9-12 15:30

Frequency MHz	Level dBµV	Transd dB	Limit dBµV	Margin dB	Detector	Line	PE
0.307500	22.40	10.9	50	27.6	AV	N	GND
0.411000	25.70	11.0	48	21.9	AV	N	GND
1.126500	20.20	11.2	46	25.8	AV	N	GND
2.566500	19.10	11.3	46	26.9	AV	N	GND
5.397000	15.60	11.5	50	34.4	AV	N	GND
12.633000	8.90	11.6	50	41.1	AV	N	GND

6. 6DB BANDWIDTH MEASUREMENT

6.1. Block Diagram of Test Setup

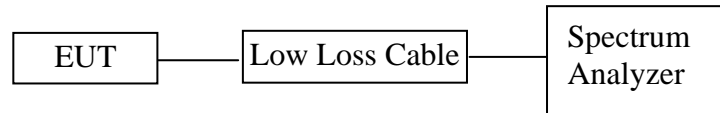

(EUT: iWOWNfit Fitness)

6.2. The Requirement For Section 15.247(a)(2)

Section 15.247(a)(2): Systems using digital modulation techniques may operate in the 902-928MHz, 2400-2483.5MHz, and 5725-5850MHz bands. The minimum 6 dB bandwidth shall be at least 500 kHz.

6.3. EUT Configuration on Measurement

The equipment is installed on the emission measurement to meet the commission requirements and operating regulations in a manner which tends to maximize its emission characteristics in normal application.

6.4. Operating Condition of EUT

6.4.1. Setup the EUT and simulator as shown as Section 6.1.

6.4.2. Turn on the power of all equipment.

6.4.3. Let the EUT work in TX modes measure it. The transmit frequency are 2402-2480MHz. We select 2402MHz, 2440MHz, and 2480MHz TX frequency to transmit.

6.5. Test Procedure

6.5.1. The transmitter output was connected to the spectrum analyzer through a low loss cable.

6.5.2. Set RBW of spectrum analyzer to 100 kHz and VBW to 300 kHz.

6.5.3. The 6dB bandwidth is defined as the total spectrum the power of which is higher than peak power minus 6dB.

6.6. Test Result

Test Lab: Shielding room
Test Engineer: Bob

Channel	Frequency (MHz)	6 dB Bandwidth (MHz)	Minimum Limit(MHz)	PASS/FAIL
0	2402	0.702	0.5	PASS
19	2440	0.696	0.5	PASS
39	2480	0.702	0.5	PASS

The spectrum analyzer plots are attached as below.

channel 0

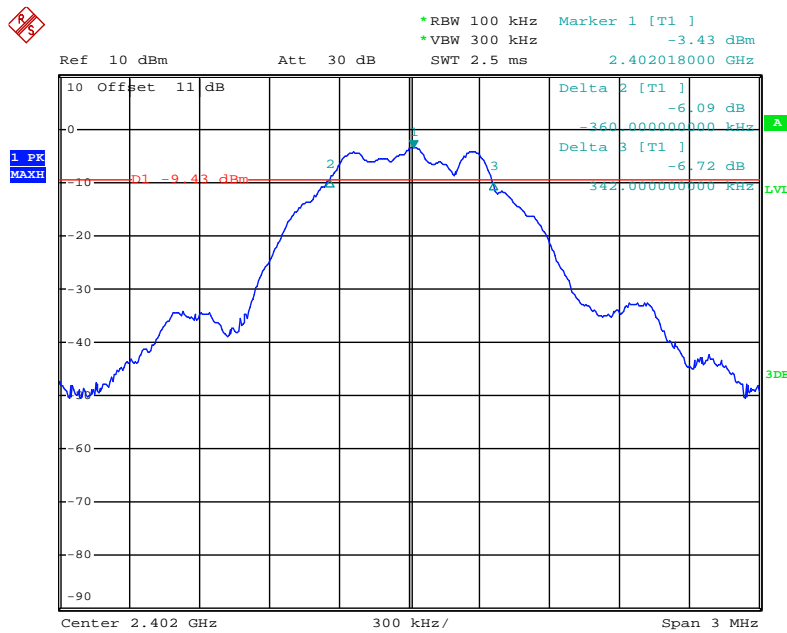

channel 19

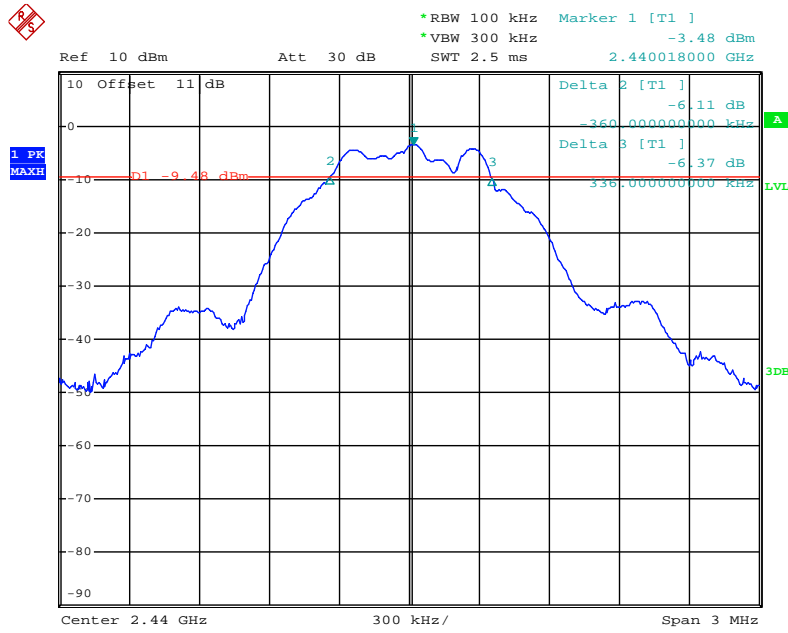

channel 39

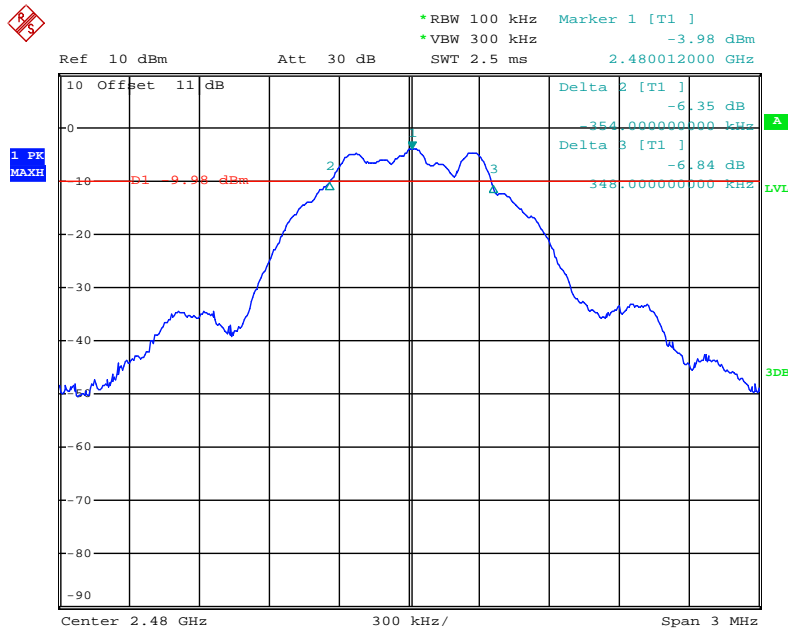

7. MAXIMUM PEAK OUTPUT POWER

7.1. Block Diagram of Test Setup

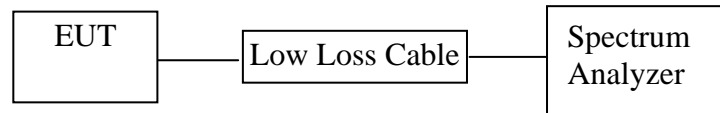

(EUT: iWOWNfit Fitness)

7.2. The Requirement For Section 15.247(b)(3)

Section 15.247(b)(3): For systems using digital modulation in the 902-928MHz, 2400-2483.5MHz, and 5725-5850MHz bands: 1 Watt.

7.3. EUT Configuration on Measurement

The equipment are installed on the emission Measurement to meet the commission requirements and operating regulations in a manner which tends to maximize its emission characteristics in normal application.

7.4. Operating Condition of EUT

7.4.1. Setup the EUT and simulator as shown as Section 7.1.

7.4.2. Turn on the power of all equipment.

7.4.3. Let the EUT work in TX modes measure it. The transmit frequency are 2402-2480MHz. We select 2402MHz, 2440MHz, and 2480MHz TX frequency to transmit.

7.5. Test Procedure

7.5.1. The transmitter output was connected to the spectrum analyzer through a low loss cable.

7.5.2. Set RBW of spectrum analyzer to 1 MHz and VBW to 3MHz.

7.5.3. Measurement the maximum peak output power.

7.6. Test Result

Test Lab: Shielding room

Test Engineer: Bob

Channel	Frequency (MHz)	Peak Power Output (dBm)	Peak Power Limit (dBm)	Pass / Fail
0	2402	-3.19	30	PASS
19	2440	-3.33	30	PASS
39	2480	-3.87	30	PASS

The spectrum analyzer plots are attached as below.

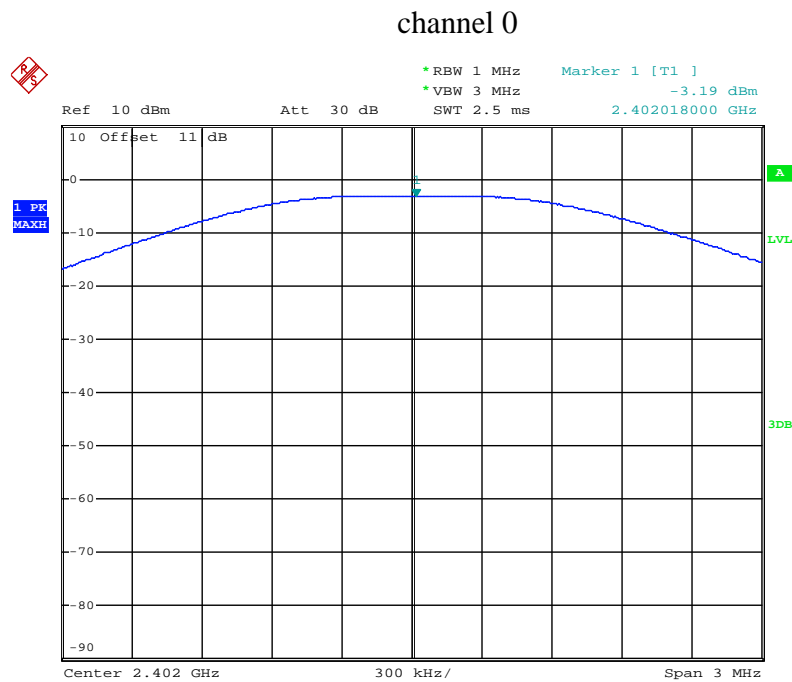

channel 19

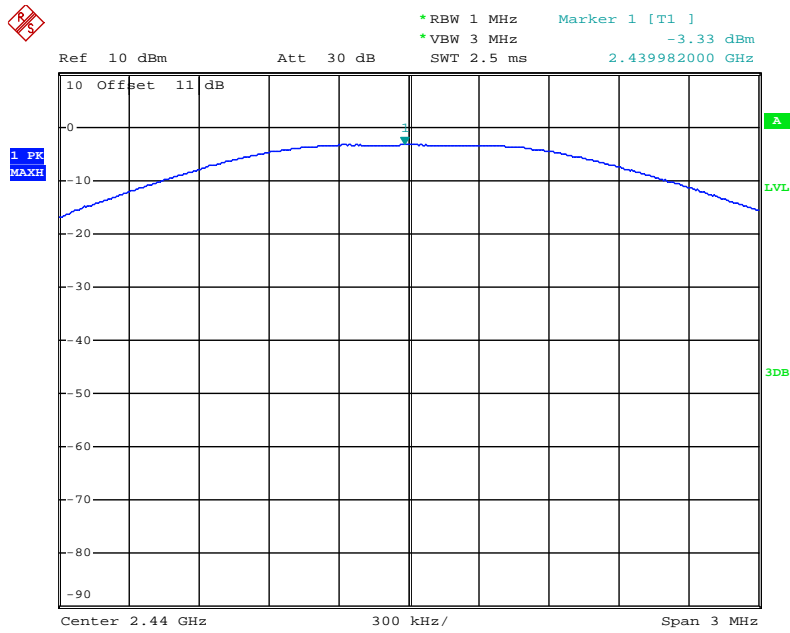

channel 39

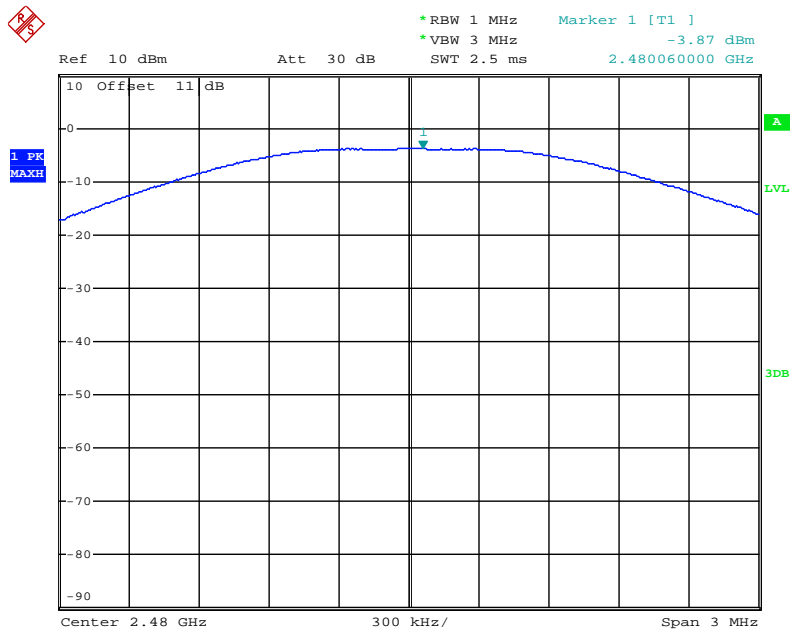

8. POWER SPECTRAL DENSITY MEASUREMENT

8.1. Block Diagram of Test Setup

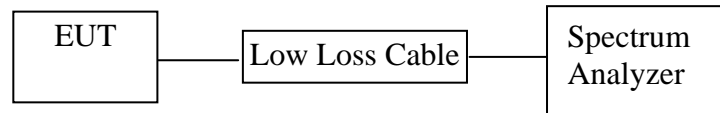

(EUT: iWOWNfit Fitness)

8.2. The Requirement For Section 15.247(e)

Section 15.247(e): For digitally modulated systems, the power spectral density conducted from the intentional radiator to the antenna shall not be greater than 8 dBm in any 3 kHz band during any time interval of continuous transmission.

8.3. EUT Configuration on Measurement

The equipment are installed on the emission Measurement to meet the commission requirements and operating regulations in a manner which tends to maximize its emission characteristics in normal application.

8.4. Operating Condition of EUT

8.4.1. Setup the EUT and simulator as shown as Section 8.1.

8.4.2. Turn on the power of all equipment.

8.4.3. Let the EUT work in TX modes measure it. The transmit frequency are 2402-2480MHz. We select 2402MHz, 2440MHz, and 2480MHz TX frequency to transmit.

8.5. Test Procedure

8.5.1. The transmitter output was connected to the spectrum analyzer through a low loss cable.

8.5.2. Measurement Procedure PKPSD:

8.5.3. This procedure must be used if maximum peak conducted output power was used to demonstrate compliance to the fundamental output power limit, and is optional if the maximum (average) conducted output power was used to demonstrate compliance.

1. Set analyzer center frequency to DTS channel center frequency.
2. Set the span to 1.5 times the DTS channel bandwidth.
3. Set the RBW to: $3 \text{ kHz} \leq \text{RBW} \leq 100 \text{ kHz}$.
4. Set the VBW $\geq 3 \times \text{RBW}$.
5. Detector = peak.
6. Sweep time = auto couple.
7. Trace mode = max hold.
8. Allow trace to fully stabilize.
9. Use the peak marker function to determine the maximum amplitude level.
10. If measured value exceeds limit, reduce RBW (no less than 3kHz) and repeat.

8.5.4.Measurement the maximum power spectral density.

8.6.Test Result

Test Lab: Shielding room

Test Engineer: Bob

CHANNEL NUMBER	FREQUENCY (MHz)	PSD (dBm/3KHz)	LIMIT (dBm/3KHz)	PASS/FAIL
0	2402	-21.29	8	PASS
19	2440	-21.38	8	PASS
39	2480	-22.03	8	PASS

The spectrum analyzer plots are attached as below.

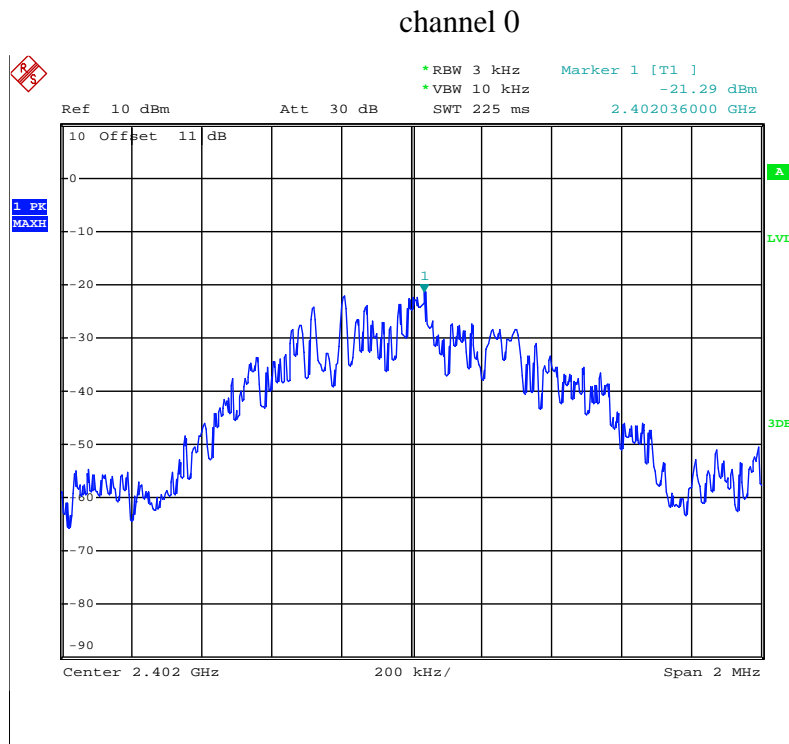

channel 19

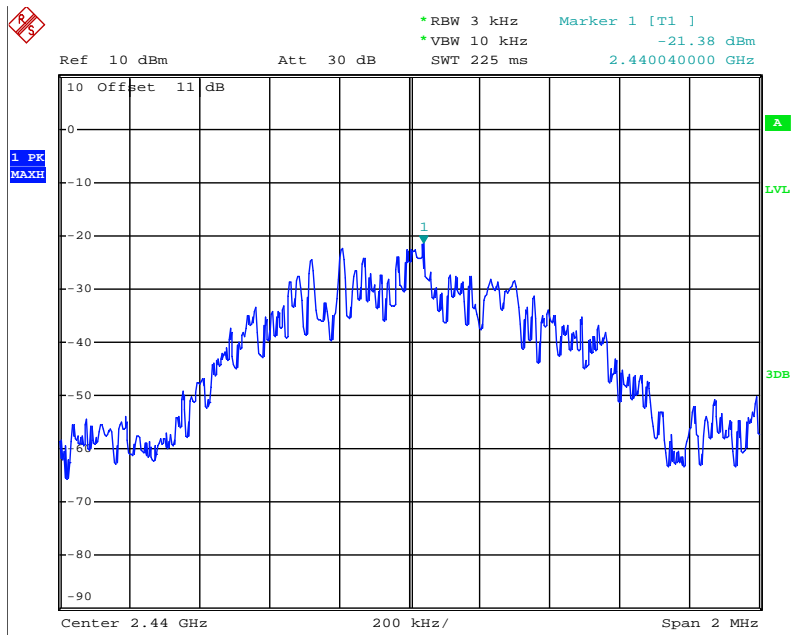

channel 39

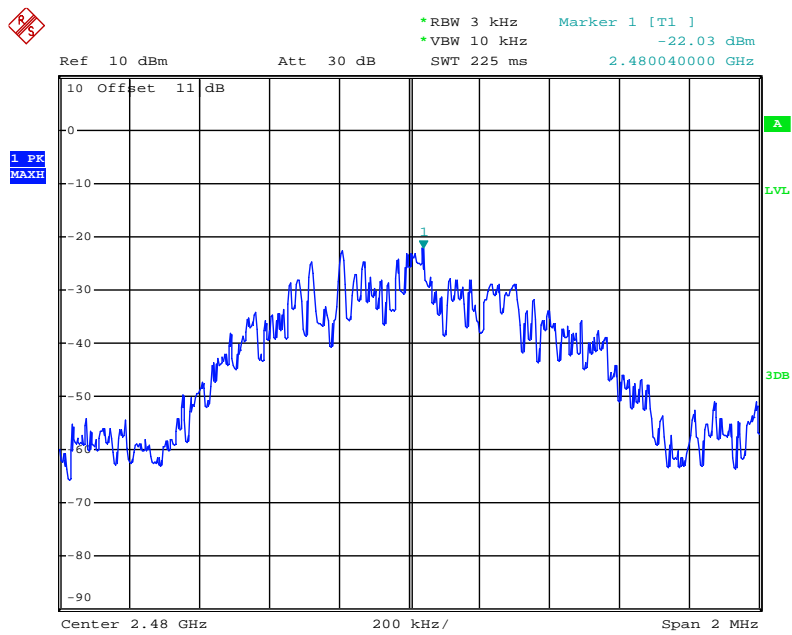

9. BAND EDGE COMPLIANCE TEST

9.1. Block Diagram of Test Setup

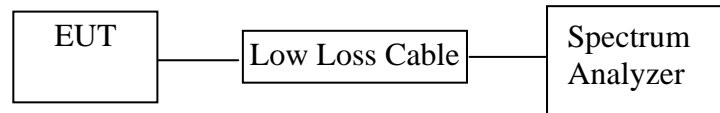

(EUT: iWOWNfit Fitness)

9.2. The Requirement For Section 15.247(d)

Section 15.247(d): In any 100 kHz bandwidth outside the frequency band in which the spread spectrum or digitally modulated intentional radiator is operating, the radio frequency power that is produced by the intentional radiator shall be at least 20 dB below that in the 100 kHz bandwidth within the band that contains the highest level of the desired power, based on either an RF conducted or a radiated measurement, provided the transmitter demonstrates compliance with the peak conducted power limits. If the transmitter complies with the conducted power limits based on the use of RMS averaging over a time interval, as permitted under paragraph (b)(3) of this section, the attenuation required under this paragraph shall be 30 dB instead of 20 dB. Attenuation below the general limits specified in Section 15.209(a) is not required. In addition, radiated emissions which fall in the restricted bands, as defined in Section 15.205(a), must also comply with the radiated emission limits specified in Section 15.209(a).

9.3. EUT Configuration on Measurement

The equipment are installed on the emission Measurement to meet the commission requirements and operating regulations in a manner which tends to maximize its emission characteristics in normal application.

9.4. Operating Condition of EUT

9.4.1. Setup the EUT and simulator as shown as Section 9.1.

9.4.2. Turn on the power of all equipment.

9.4.3. Let the EUT work in TX modes measure it. The transmit frequency are 2402-2480MHz. We select 2402MHz, 2480MHz TX frequency to transmit.

9.5. Test Procedure

Conducted Band Edge:

9.5.1. The transmitter output was connected to the spectrum analyzer via a low loss cable.

9.5.2. Set RBW of spectrum analyzer to 100 kHz and VBW to 300 kHz.

9.5.3. Radiate Band Edge:

9.5.4. The EUT is placed on a turntable, which is 1.5m above the ground plane and worked at highest radiated power.

9.5.5. The turntable was rotated for 360 degrees to determine the position of maximum emission level.

9.5.6. EUT is set 3m away from the receiving antenna, which is varied from 1m to 4m to find out the highest emission.

9.5.7. Set the spectrum analyzer in the following setting in order to capture the lower and upper band-edges of the emission:

9.5.8. RBW=1MHz, VBW=1MHz

9.5.9. The band edges was measured and recorded.

9.6. Test Result

Pass.

Test Lab: Shielding room

Test Engineer: Bob

Conducted Band Edge Result

Channel	Frequency	Delta peak to band emission	Limit(dBc)
0	2.402GHz	48.78	20
39	2.480GHz	46.54	20

The spectrum analyzer plots are attached as below.

channel 0

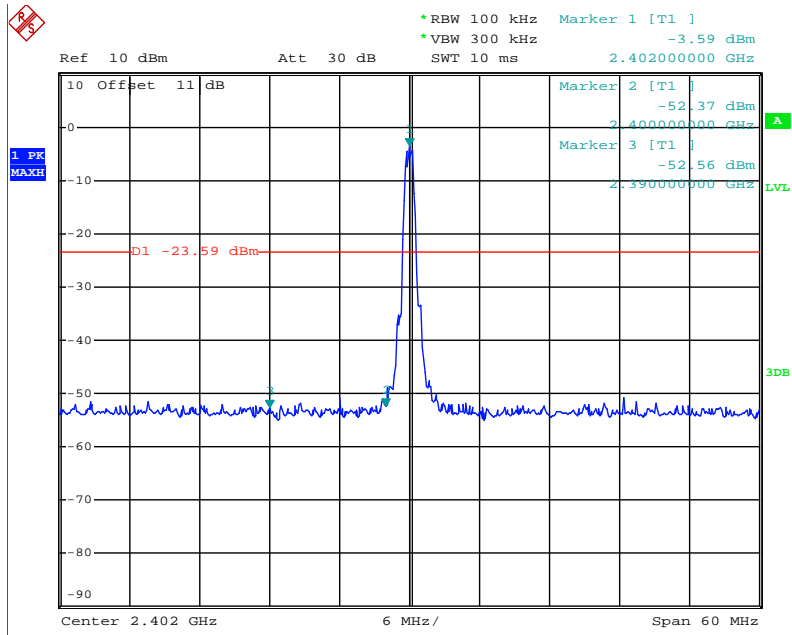

channel 39

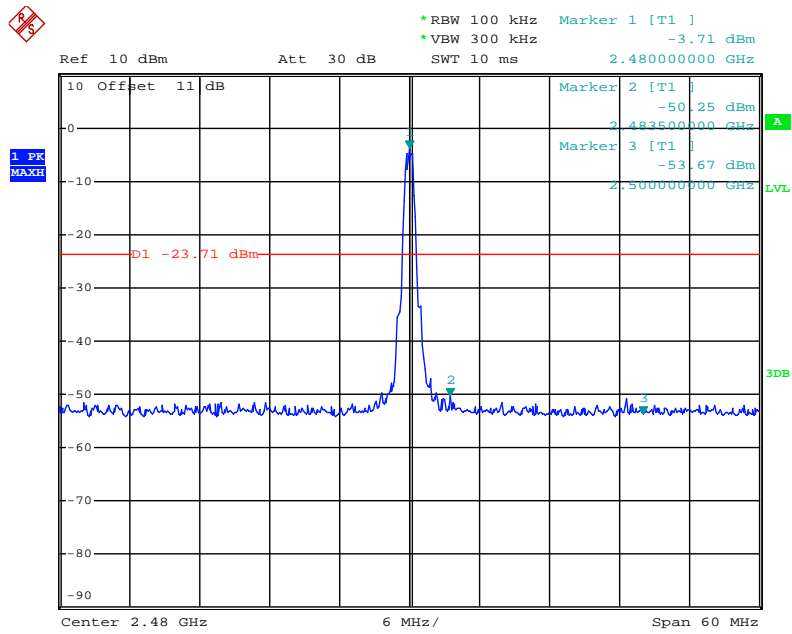

Radiated Band Edge Result



ACCURATE TECHNOLOGY CO., LTD.

F1,Bldg,A,Changyuan New Material Port Keyuan Rd,
Science & Industry Park,Nanshan Shenzhen,P.R.China

Site: 1# Chamber

Tel:+86-0755-26503290

Fax:+86-0755-26503396

Job No.: FRANK2018 #757

Standard: FCC PK

Test item: Radiation Test

Temp.(C)/Hum.(%) 23 C / 48 %

EUT: iWOWNfit Fitness

Mode: TX2402MHz

Model: i7A

Manufacturer: Shenzhen IWOWN Technology Co.,Ltd

Polarization: Horizontal

Power Source: DC 3.7V

Date: 18/09/14/

Time: 14/33/21

Engineer Signature: Bob

Distance: 3m

Note: Report NO.:ATE20171665

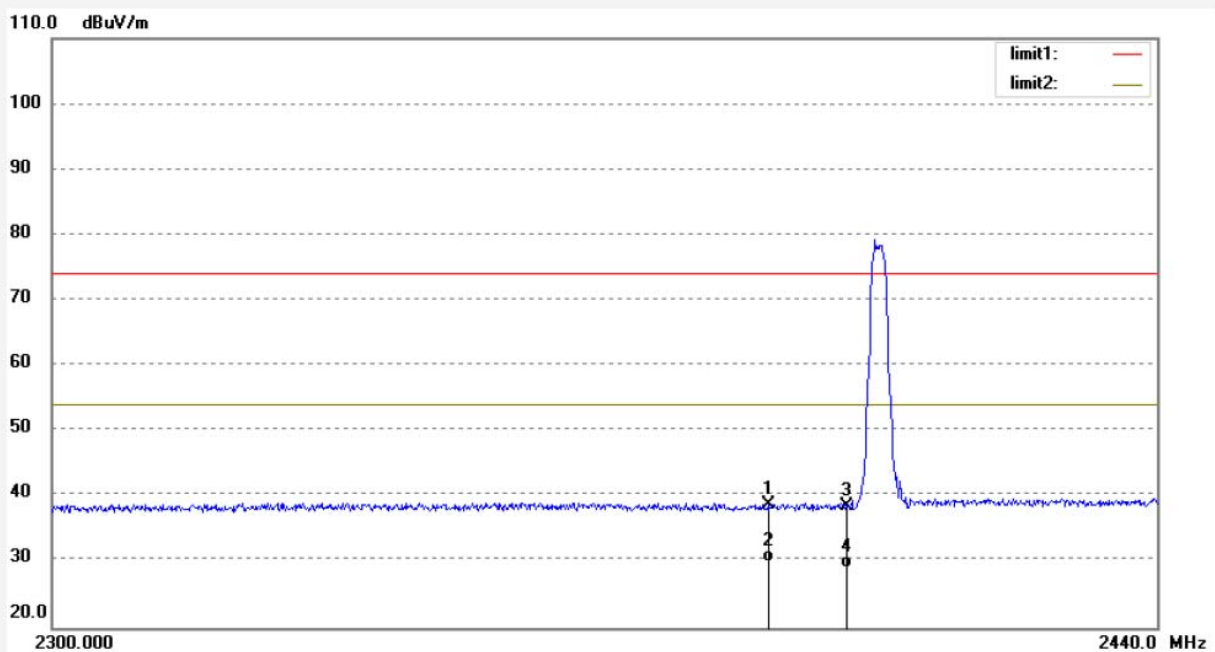

No.	Freq. (MHz)	Reading (dBuV/m)	Factor (dB)	Result (dBuV/m)	Limit (dBuV/m)	Margin (dB)	Detector	Height (cm)	Degree (deg.)	Remark
1	2390.000	38.02	0.79	38.81	74.00	-35.19	peak	200	102	
2	2390.000	29.21	0.79	30.00	54.00	-24.00	AVG	250	122	
3	2400.000	37.75	0.88	38.63	74.00	-35.37	peak	200	95	
4	2400.000	28.15	0.88	29.03	54.00	-24.97	AVG	250	166	

ACCURATE TECHNOLOGY CO., LTD.

 F1,Bldg,A,Changyuan New Material Port Keyuan Rd,
 Science & Industry Park,Nanshan Shenzhen,P.R.China

Site: 1# Chamber

Tel:+86-0755-26503290

Fax:+86-0755-26503396

Job No.: FRANK2018 #758

Standard: FCC PK

Test item: Radiation Test

Temp.(C)/Hum.(%) 23 C / 48 %

EUT: iWOWNfit Fitness

Mode: TX2402MHz

Model: i7A

Manufacturer: Shenzhen IWOWN Technology Co.,Ltd

Polarization: Vertical

Power Source: DC 3.7V

Date: 18/09/14/

Time: 14/37/45

Engineer Signature: Bob

Distance: 3m

Note: Report NO.:ATE20171665

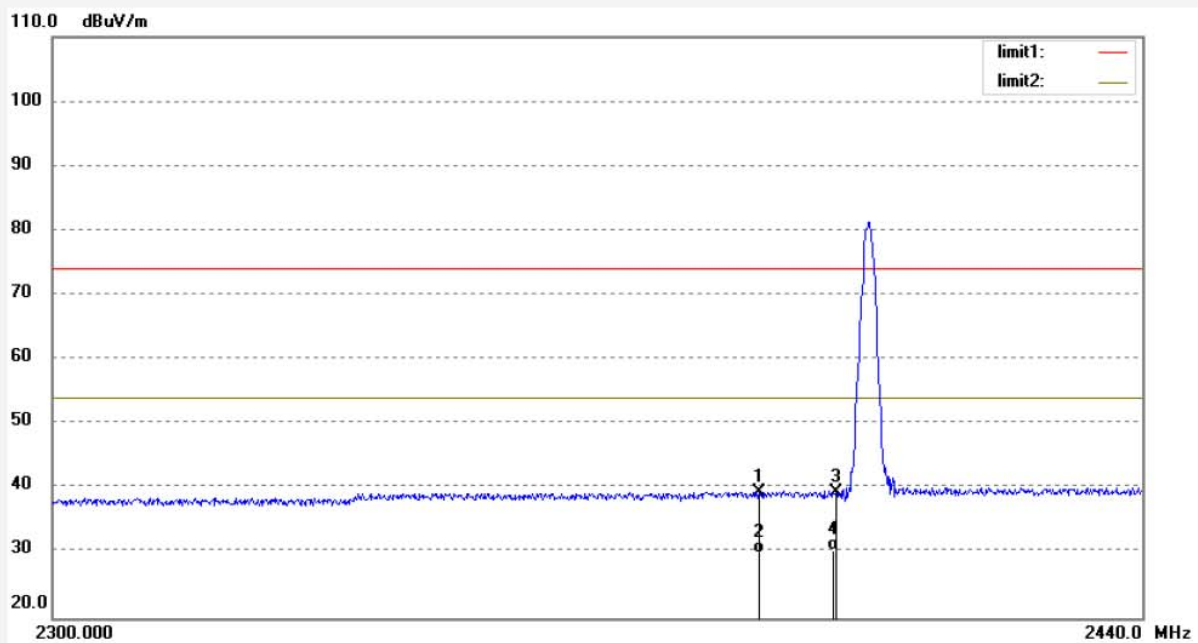

No.	Freq. (MHz)	Reading (dBuV/m)	Factor (dB)	Result (dBuV/m)	Limit (dBuV/m)	Margin (dB)	Detector	Height (cm)	Degree (deg.)	Remark
1	2390.000	38.65	0.79	39.44	74.00	-34.56	peak	150	95	
2	2390.000	29.15	0.79	29.94	54.00	-24.06	AVG	150	48	
3	2400.000	38.47	0.88	39.35	74.00	-34.65	peak	150	159	
4	2400.000	29.48	0.88	30.36	54.00	-23.64	AVG	150	102	

Job No.: FRANK2018 #759

Standard: FCC PK

Test item: Radiation Test

Temp.(C)/Hum.(%) 23 C / 48 %

EUT: iWOWNfit Fitness

Mode: TX2480MHz

Model: i7A

Manufacturer: Shenzhen IWOWN Technology Co.,Ltd

Polarization: Vertical

Power Source: DC 3.7V

Date: 18/09/14/

Time: 14/41/08

Engineer Signature: Bob

Distance: 3m

Note: Report NO.:ATE20171665

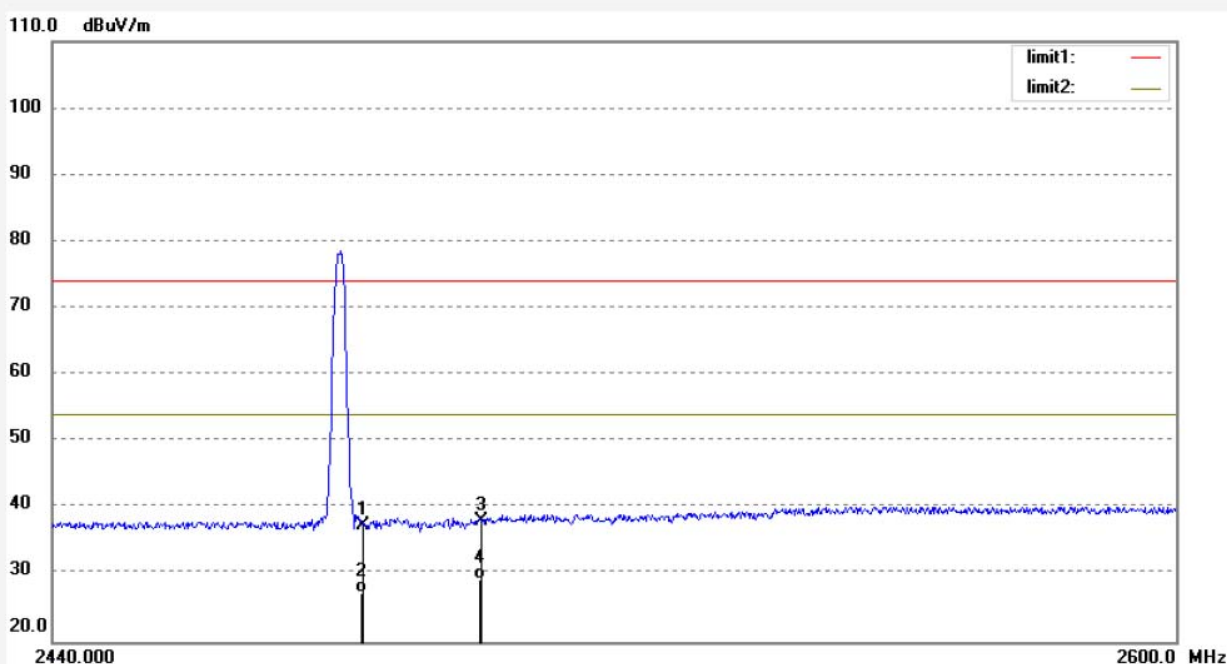

No.	Freq. (MHz)	Reading (dBuV/m)	Factor (dB)	Result (dBuV/m)	Limit (dBuV/m)	Margin (dB)	Detector	Height (cm)	Degree (deg.)	Remark
1	2483.500	36.28	1.10	37.38	74.00	-36.62	peak	150	46	
2	2483.500	26.15	1.10	27.25	54.00	-26.75	AVG	150	99	
3	2500.000	37.07	1.10	38.17	74.00	-35.83	peak	150	221	
4	2500.000	28.15	1.10	29.25	54.00	-24.75	AVG	150	103	

Job No.: FRANK2018 #760
 Standard: FCC PK
 Test item: Radiation Test
 Temp.(C)/Hum.(%) 23 C / 48 %
 EUT: iWOWNfit Fitness
 Mode: TX2480MHz
 Model: i7A

Polarization: Horizontal
 Power Source: DC 3.7V
 Date: 18/09/14/
 Time: 14/45/21
 Engineer Signature: Bob
 Distance: 3m

Manufacturer: Shenzhen IWOWN Technology Co.,Ltd

Note: Report NO.:ATE20171665

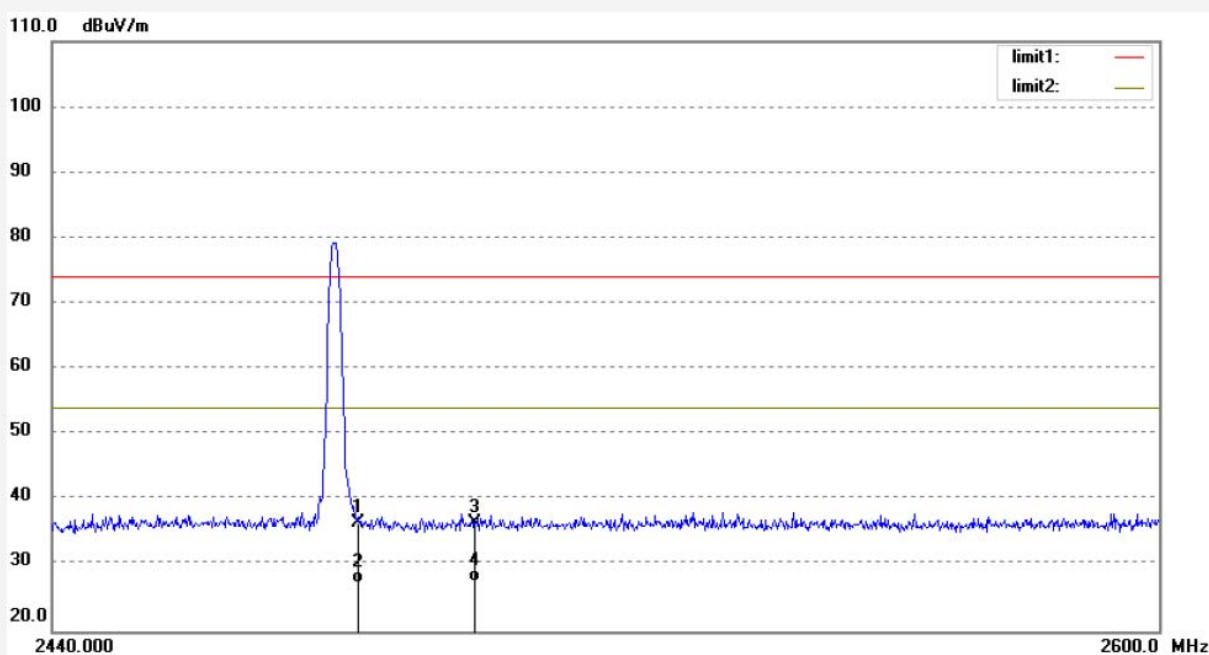

No.	Freq. (MHz)	Reading (dBuV/m)	Factor (dB)	Result (dBuV/m)	Limit (dBuV/m)	Margin (dB)	Detector	Height (cm)	Degree (deg.)	Remark
1	2483.500	35.48	1.10	36.58	74.00	-37.42	peak	250	71	
2	2483.500	26.15	1.10	27.25	54.00	-26.75	AVG	250	49	
3	2500.000	35.51	1.10	36.61	74.00	-37.39	peak	250	169	
4	2500.000	26.45	1.10	27.55	54.00	-26.45	AVG	250	102	

Note:

1. Emissions attenuated more than 20 dB below the permissible value are not reported.
2. The field strength is calculated by adding the antenna factor, high pass filter loss(if used) and cable loss, and subtracting the amplifier gain(if any)from the measured reading. The basic equation calculation is as follows:

$$\text{Result} = \text{Reading} + \text{Corrected Factor}$$

10.RADIATED SPURIOUS EMISSION TEST

10.1.Block Diagram of Test Setup

10.1.1.Block diagram of connection between the EUT and peripherals

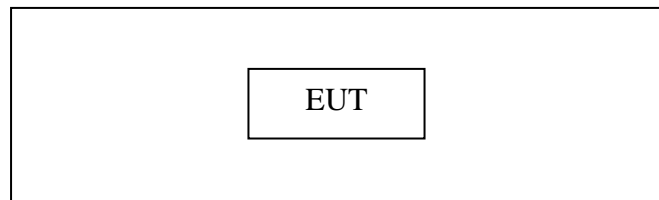

Setup: Transmitting mode

10.1.2.Semi-Anechoic Chamber Test Setup Diagram

(A)Radiated Emission Test Set-Up, Frequency below 30MHz

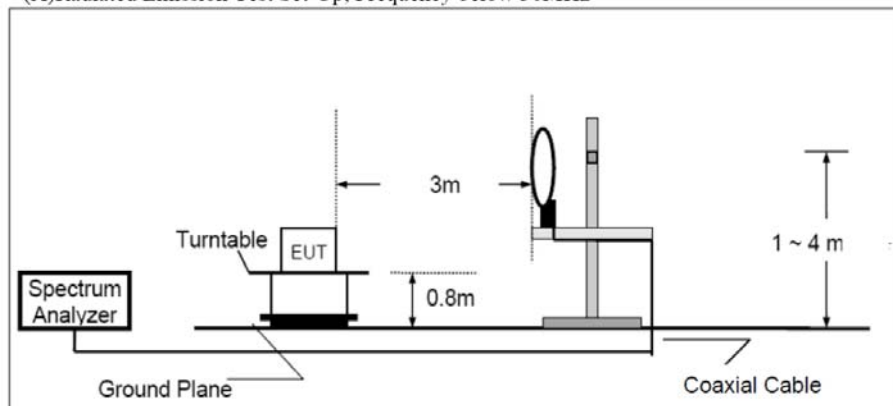

(B)Radiated Emission Test Set-Up, Frequency 30MHz-1GHz

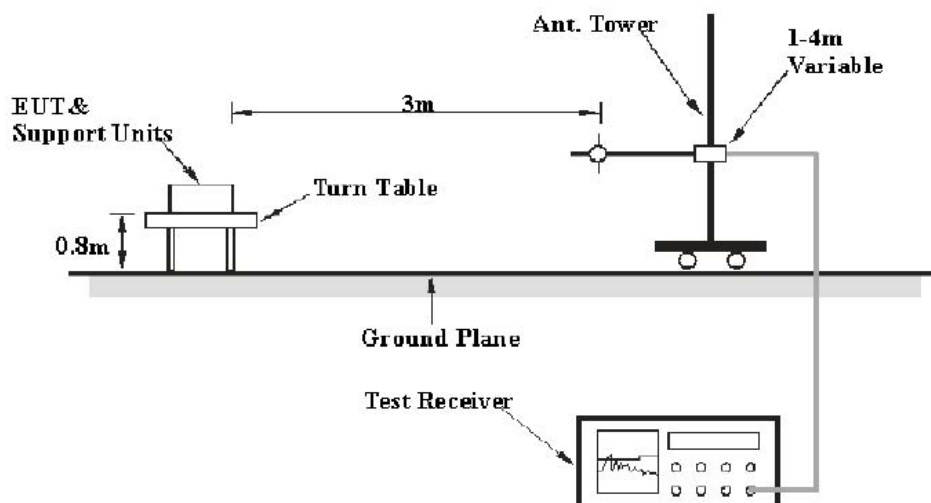

(C) Radiated Emission Test Set-Up, Frequency above 1GHz

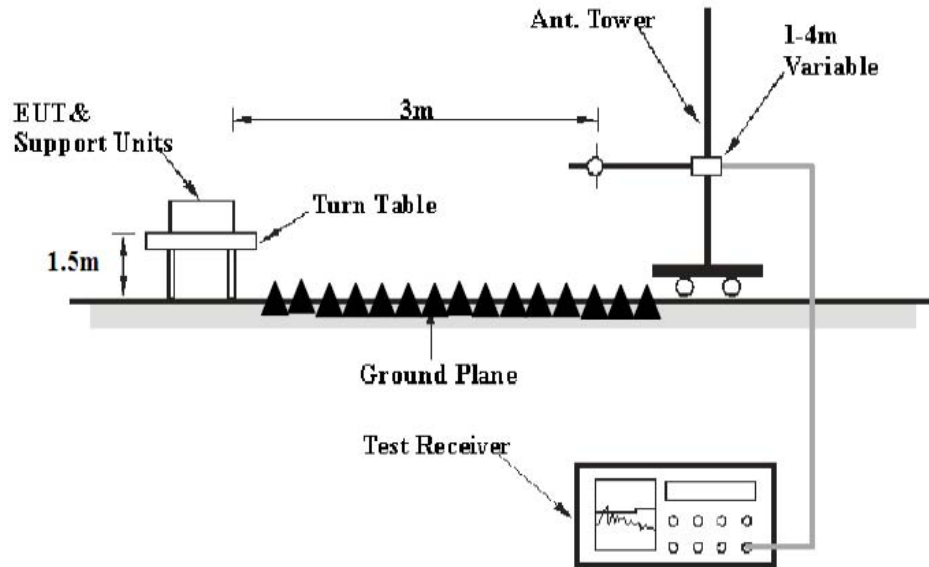

10.2. The Limit For Section 15.247(d)

Section 15.247(d): In any 100 kHz bandwidth outside the frequency band in which the spread spectrum or digitally modulated intentional radiator is operating, the radio frequency power that is produced by the intentional radiator shall be at least 20 dB below that in the 100 kHz bandwidth within the band that contains the highest level of the desired power, based on either an RF conducted or a radiated measurement, provided the transmitter demonstrates compliance with the peak conducted power limits. If the transmitter complies with the conducted power limits based on the use of RMS averaging over a time interval, as permitted under paragraph (b)(3) of this section, the attenuation required under this paragraph shall be 30 dB instead of 20 dB. Attenuation below the general limits specified in Section 15.209(a) is not required. In addition, radiated emissions which fall in the restricted bands, as defined in Section 15.205(a), must also comply with the radiated emission limits specified in Section 15.209(a).

10.3. Restricted bands of operation

10.3.1. FCC Part 15.205 Restricted bands of operation

(a) Except as shown in paragraph (d) of this section, Only spurious emissions are permitted in any of the frequency bands listed below:

MHz	MHz	MHz	GHz
0.090-0.110	16.42-16.423	399.9-410	4.5-5.15
¹ 0.495-0.505	16.69475-16.69525	608-614	5.35-5.46
2.1735-2.1905	16.80425-16.80475	960-1240	7.25-7.75
4.125-4.128	25.5-25.67	1300-1427	8.025-8.5
4.17725-4.17775	37.5-38.25	1435-1626.5	9.0-9.2
4.20725-4.20775	73-74.6	1645.5-1646.5	9.3-9.5
6.215-6.218	74.8-75.2	1660-1710	10.6-12.7
6.26775-6.26825	108-121.94	1718.8-1722.2	13.25-13.4
6.31175-6.31225	123-138	2200-2300	14.47-14.5
8.291-8.294	149.9-150.05	2310-2390	15.35-16.2
8.362-8.366	156.52475-156.52525	2483.5-2500	17.7-21.4
8.37625-8.38675	156.7-156.9	2690-2900	22.01-23.12
8.41425-8.41475	162.0125-167.17	3260-3267	23.6-24.0
12.29-12.293	167.72-173.2	3332-3339	31.2-31.8
12.51975-12.52025	240-285	3345.8-3358	36.43-36.5
12.57675-12.57725	322-335.4	3600-4400	(²)
13.36-13.41			

¹Until February 1, 1999, this restricted band shall be 0.490-0.510

²Above 38.6

(b) Except as provided in paragraphs (d) and (e), the field strength of emission appearing within these frequency bands shall not exceed the limits shown in Section 15.209. At frequencies equal to or less than 1000MHz, Compliance with the limits in Section 15.209 shall be demonstrated using measurement instrumentation employing a CISPR quasi-peak detector. Above 1000MHz, compliance with the emission limits in Section 15.209 shall be demonstrated based on the average value of the measured emissions. The provisions in Section 15.35 apply to these measurements.

10.4. Configuration of EUT on Measurement

The equipment are installed on Radiated Emission Measurement to meet the commission requirements and operating regulations in a manner which tends to maximize its emission characteristics in normal application.

10.5. Operating Condition of EUT

10.5.1. Setup the EUT and simulator as shown as Section 10.1.

10.5.2. Turn on the power of all equipment.

10.5.3. Let the EUT work in TX modes measure it. The transmit frequency are 2402-2480MHz. We select 2402MHz, 2440MHz, and 2480MHz TX frequency to transmit.

10.6. Test Procedure

The EUT and its simulators are placed on a turntable, which is 0.8 meter high above ground (Below 1GHz). The EUT and its simulators are placed on a turntable, which is 1.5 meter high above ground (Above 1GHz). The turntable can rotate 360 degrees to determine the position of the maximum emission level. EUT is set 3.0 meters away from the receiving antenna, which is mounted on an antenna tower. The antenna can be moved up and down between 1.0 meter and 4 meters to find out the maximum emission level. Broadband antenna (calibrated bi-log antenna) is used as receiving antenna. Both horizontal and vertical polarizations of the antenna are set on measurement. In order to find the maximum emission levels, all of the EUT location must be manipulated according to ANSI C63.10:2013 on radiated emission measurement. This EUT was tested in 3 orthogonal positions and the worst case position data was reported.

The bandwidth of test receiver is set at 9 kHz in below 30MHz. and set at 120 kHz in 30-1000MHz, and 1MHz in above 1000MHz.

The frequency range from 9 kHz to 26.5GHz is checked.

The final measurement in band 9-90 kHz, 110-490 kHz and above 1000MHz is performed with Average detector. Except those frequency bands mention above, the final measurement for frequencies below 1000MHz is performed with Quasi Peak detector.

The field strength is calculated by adding the antenna factor, and cable loss, and subtracting the amplifier gain from the measured reading.

10.7.Data Sample

Frequency (MHz)	Reading (dB μ v)	Factor (dB/m)	Result (dB μ v/m)	Limit (dB μ v/m)	Margin (dB)	Remark
X.XX	43.85	-22.22	21.63	43.5	-21.87	QP

Frequency(MHz) = Emission frequency in MHz

Reading(dB μ v) = Uncorrected Analyzer/Receiver reading

Factor (dB/m) = Antenna factor + Cable Loss – Amplifier gain

Result(dB μ v/m) = Reading(dB μ v) + Factor(dB/m)

Limit (dB μ v/m) = Limit stated in standard

Margin (dB) = Result(dB μ v/m) - Limit (dB μ v/m)

QP = Quasi-peak Reading

Calculation Formula:

Margin(dB) = Result (dB μ V/m)–Limit(dB μ V/m)

Result(dB μ V/m)= Reading(dB μ V)+ Factor(dB/m)

The “Margin” column of the following data tables indicates the degree of compliance with the applicable limit. For example, a margin of -7dB means the emission is 7dB below the limit.

10.8.The Field Strength of Radiation Emission Measurement Results

Pass.

Test Lab: 3m Anechoic chamber

Test Engineer: Bob

The frequency range from 9kHz to 26.5GHz is checked.

Note: 1. Emissions attenuated more than 20 dB below the permissible value are not reported.

2. *: Denotes restricted band of operation.

3. The radiation emissions from 9kHz-30MHz and 18-26.5GHz are not reported, because the test values lower than the limits of 20dB.

The spectrum analyzer plots are attached as below.

Below 1GHz

ACCURATE TECHNOLOGY CO., LTD.

 F1,Bldg,A,Changyuan New Material Port Keyuan Rd,
 Science & Industry Park,Nanshan Shenzhen,P.R.China

Site: 1# Chamber

Tel:+86-0755-26503290

Fax:+86-0755-26503396

Job No.: FRANK2018 #745

Standard: FCC Class B 3M Radiated

Test item: Radiation Test

Temp.(C)/Hum.(%) 25 C / 55 %

EUT: iWOWNfit Fitness

Mode: TX2402MHz

Model: i7A

Manufacturer: Shenzhen IWOWN Technology Co.,Ltd

Polarization: Vertical

Power Source: DC 3.7V

Date: 18/09/14/

Time: 13/44/02

Engineer Signature: Bob

Distance:

Note: Report NO.:ATE20171665

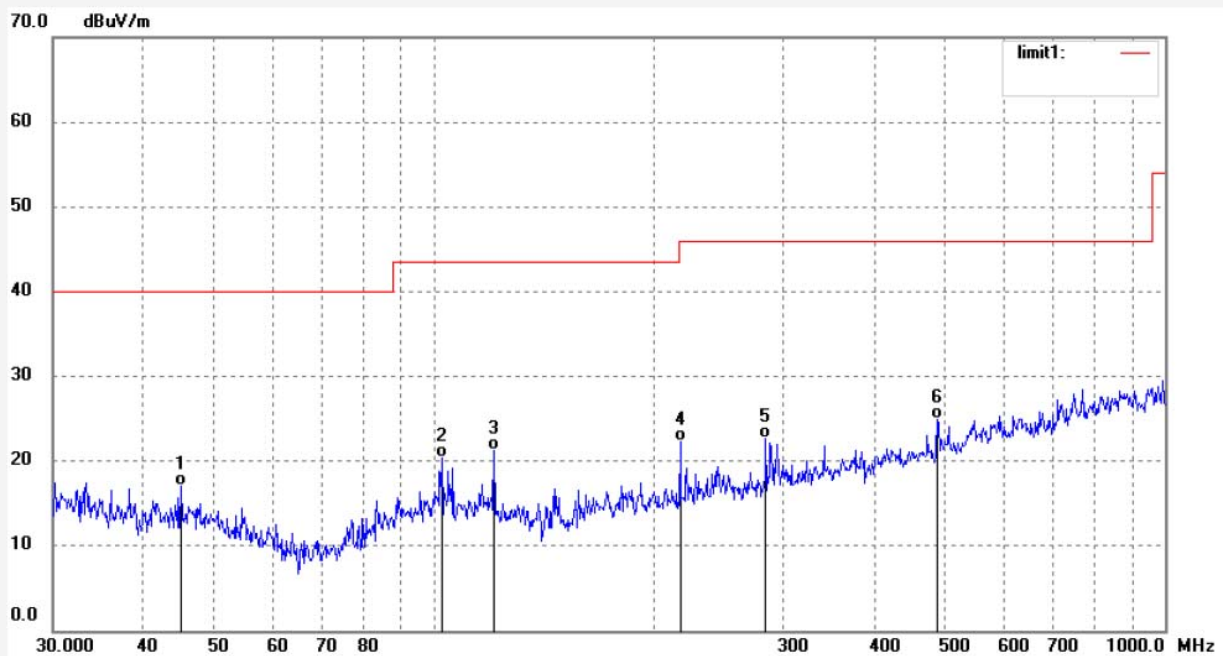

No.	Freq. (MHz)	Reading (dBuV/m)	Factor (dB)	Result (dBuV/m)	Limit (dBuV/m)	Margin (dB)	Detector	Height (cm)	Degree (deg.)	Remark
1	44.9369	36.66	-19.63	17.03	40.00	-22.97	QP	100	228	
2	102.2518	39.32	-18.96	20.36	43.50	-23.14	QP	100	130	
3	120.6118	40.80	-19.59	21.21	43.50	-22.29	QP	100	149	
4	216.8803	40.84	-18.60	22.24	46.00	-23.76	QP	100	66	
5	284.2606	39.51	-16.92	22.59	46.00	-23.41	QP	100	115	
6	488.3263	37.52	-12.50	25.02	46.00	-20.98	QP	100	302	

Job No.: FRANK2018 #746

Standard: FCC Class B 3M Radiated

Test item: Radiation Test

Temp.(C)/Hum.(%) 25 C / 55 %

EUT: iWOWNfit Fitness

Mode: TX2402MHz

Model: i7A

Manufacturer: Shenzhen IWOWN Technology Co.,Ltd

Polarization: Horizontal

Power Source: DC 3.7V

Date: 18/09/14/

Time: 13/46/33

Engineer Signature: Bob

Distance:

Note: Report NO.:ATE20171665

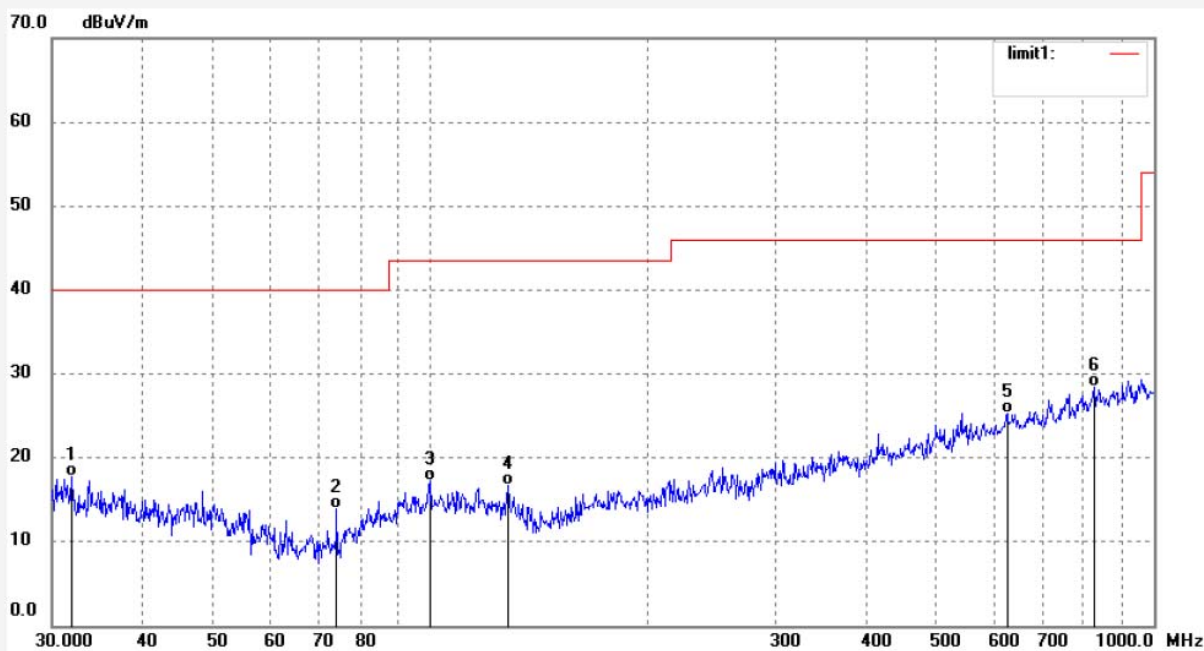

No.	Freq. (MHz)	Reading (dBuV/m)	Factor (dB)	Result (dBuV/m)	Limit (dBuV/m)	Margin (dB)	Detector	Height (cm)	Degree (deg.)	Remark
1	31.9586	35.75	-18.00	17.75	40.00	-22.25	QP	200	205	
2	74.2695	38.46	-24.52	13.94	40.00	-26.06	QP	200	61	
3	100.1187	35.85	-18.60	17.25	43.50	-26.25	QP	200	214	
4	128.0355	36.79	-20.16	16.63	43.50	-26.87	QP	200	59	
5	626.6878	35.12	-9.82	25.30	46.00	-20.70	QP	200	156	
6	827.1794	34.96	-6.52	28.44	46.00	-17.56	QP	200	302	

Job No.: FRANK2018 #747

Polarization: Horizontal

Standard: FCC Class B 3M Radiated

Power Source: DC 3.7V

Test item: Radiation Test

Date: 18/09/14/

Temp.(C)/Hum.(%) 25 C / 55 %

Time: 13/48/42

EUT: iWOWNfit Fitness

Engineer Signature: Bob

Mode: TX2440MHz

Distance:

Model: i7A

Manufacturer: Shenzhen IWOWN Technology Co.,Ltd

Note: Report NO.:ATE20171665

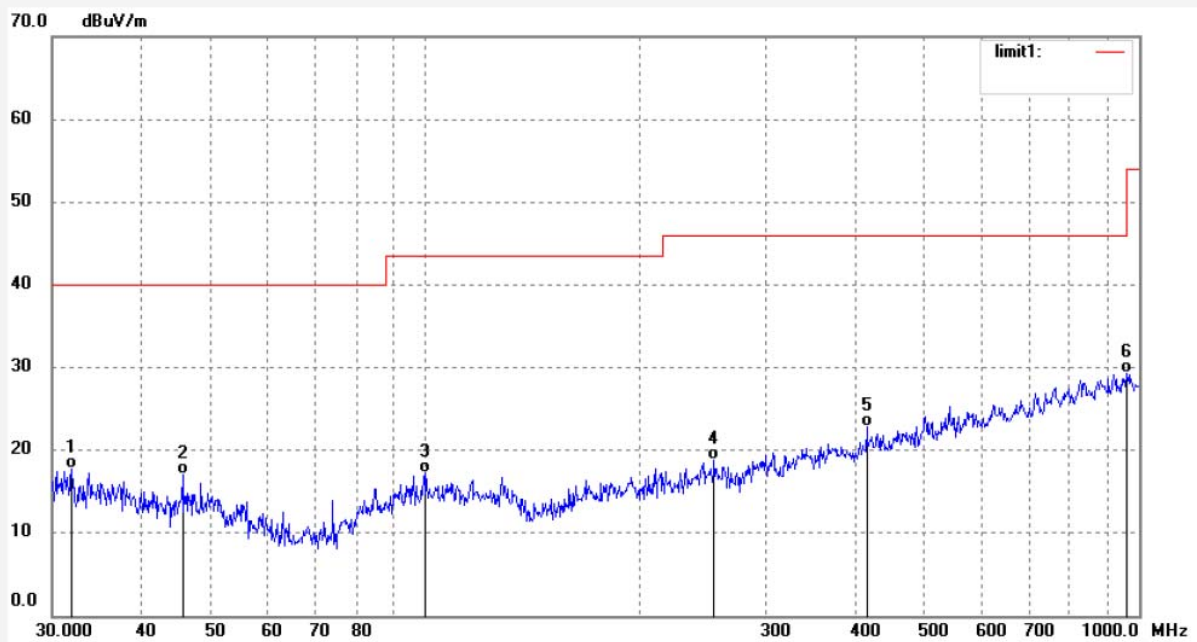

No.	Freq. (MHz)	Reading (dBuV/m)	Factor (dB)	Result (dBuV/m)	Limit (dBuV/m)	Margin (dB)	Detector	Height (cm)	Degree (deg.)	Remark
1	31.9586	35.75	-18.00	17.75	40.00	-22.25	QP	200	66	
2	45.7332	36.70	-19.63	17.07	40.00	-22.93	QP	200	201	
3	100.1187	35.85	-18.60	17.25	43.50	-26.25	QP	200	192	
4	254.0312	36.61	-17.82	18.79	46.00	-27.21	QP	200	112	
5	415.4485	36.66	-13.76	22.90	46.00	-23.10	QP	200	56	
6	962.0878	34.40	-5.08	29.32	54.00	-24.68	QP	200	32	



ACCURATE TECHNOLOGY CO., LTD.

F1,Bldg,A,Changyuan New Material Port Keyuan Rd,
Science & Industry Park,Nanshan Shenzhen,P.R.China

Site: 1# Chamber

Tel:+86-0755-26503290

Fax:+86-0755-26503396

Job No.: FRANK2018 #748

Standard: FCC Class B 3M Radiated

Test item: Radiation Test

Temp.(C)/Hum.(%) 25 C / 55 %

EUT: iWOWNfit Fitness

Mode: TX2440MHz

Model: i7A

Manufacturer: Shenzhen IWOWN Technology Co.,Ltd

Polarization: Vertical

Power Source: DC 3.7V

Date: 18/09/14/

Time: 13/51/40

Engineer Signature: Bob

Distance:

Note: Report NO.:ATE20171665

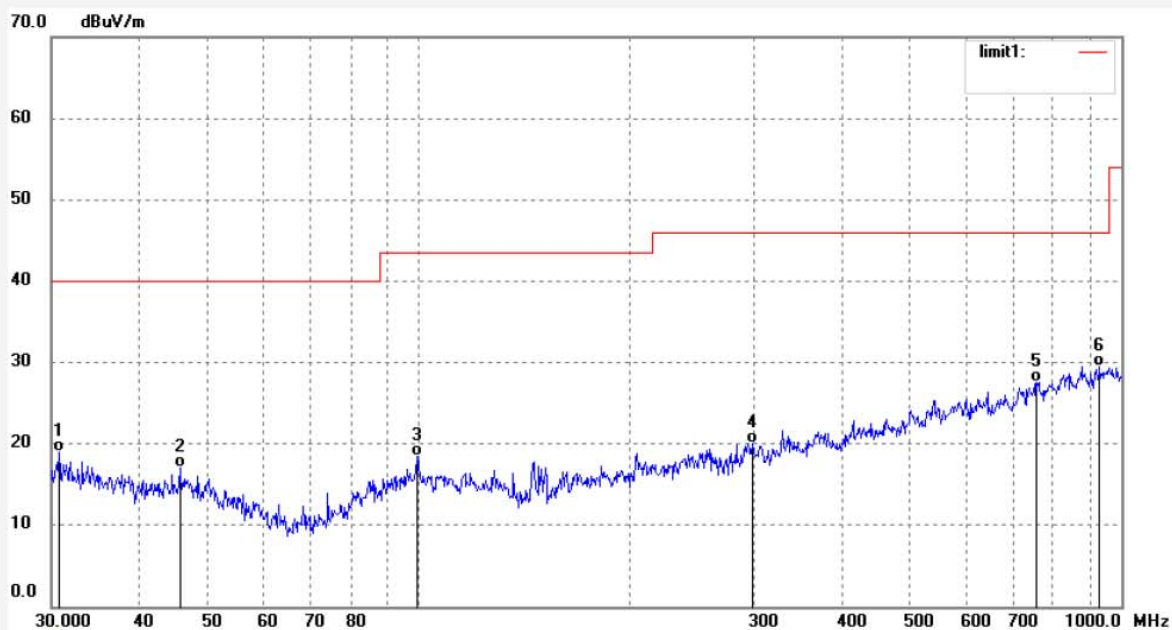

No.	Freq. (MHz)	Reading (dBuV/m)	Factor (dB)	Result (dBuV/m)	Limit (dBuV/m)	Margin (dB)	Detector	Height (cm)	Degree (deg.)	Remark
1	30.7469	36.85	-17.89	18.96	40.00	-21.04	QP	100	323	
2	45.7332	36.70	-19.63	17.07	40.00	-22.93	QP	100	201	
3	99.4176	37.16	-18.71	18.45	43.50	-25.05	QP	100	156	
4	298.5932	36.67	-16.62	20.05	46.00	-25.95	QP	100	95	
5	757.6200	35.42	-7.83	27.59	46.00	-18.41	QP	100	226	
6	932.1404	34.92	-5.43	29.49	46.00	-16.51	QP	100	32	

Job No.: FRANK2018 #749

Standard: FCC Class B 3M Radiated

Test item: Radiation Test

Temp.(C)/Hum.(%) 25 C / 55 %

EUT: iWOWNfit Fitness

Mode: TX2480MHz

Model: i7A

Manufacturer: Shenzhen IWOWN Technology Co.,Ltd

Polarization: Vertical

Power Source: DC 3.7V

Date: 18/09/14/

Time: 13/54/07

Engineer Signature: Bob

Distance:

Note: Report NO.:ATE20171665

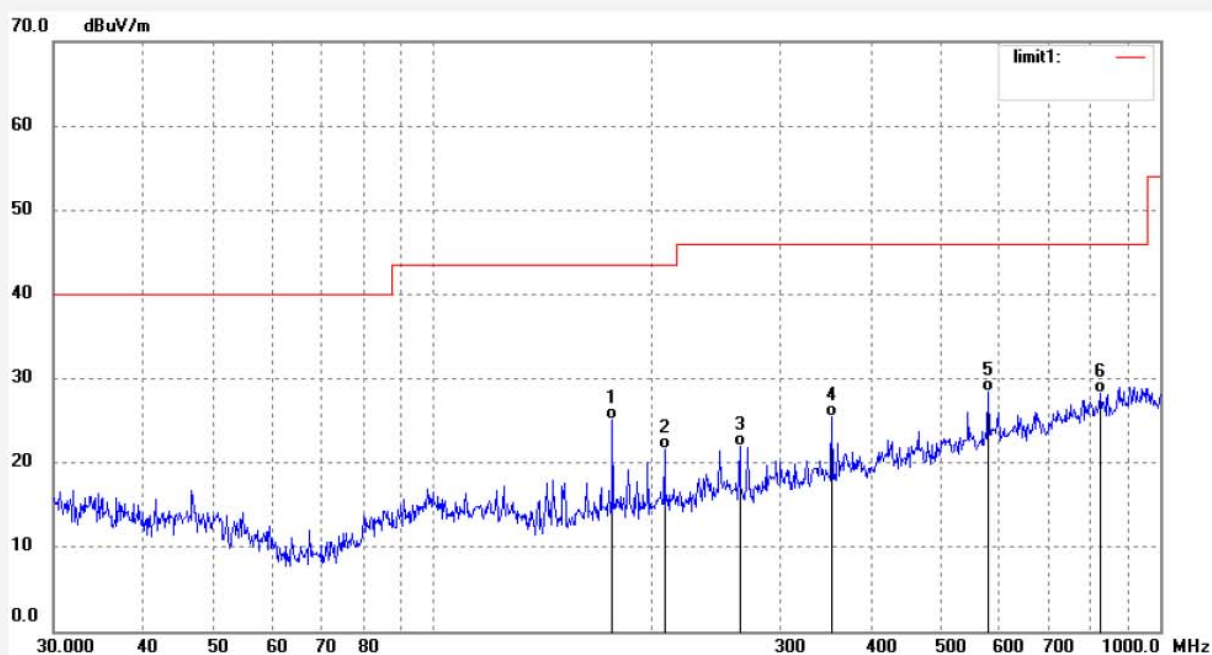

No.	Freq. (MHz)	Reading (dBuV/m)	Factor (dB)	Result (dBuV/m)	Limit (dBuV/m)	Margin (dB)	Detector	Height (cm)	Degree (deg.)	Remark
1	176.2747	45.10	-20.04	25.06	43.50	-18.44	QP	100	302	
2	207.9260	40.57	-18.95	21.62	43.50	-21.88	QP	100	112	
3	264.0416	39.59	-17.60	21.99	46.00	-24.01	QP	100	294	
4	353.4471	40.45	-14.94	25.51	46.00	-20.49	QP	100	320	
5	580.0705	38.88	-10.42	28.46	46.00	-17.54	QP	100	126	
6	827.1794	34.76	-6.52	28.24	46.00	-17.76	QP	100	220	

Job No.: FRANK2018 #750

Standard: FCC Class B 3M Radiated

Test item: Radiation Test

Temp.(C)/Hum.(%) 25 C / 55 %

EUT: iWOWNfit Fitness

Mode: TX2480MHz

Model: i7A

Manufacturer: Shenzhen IWOWN Technology Co.,Ltd

Polarization: Horizontal

Power Source: DC 3.7V

Date: 18/09/14/

Time: 13/57/45

Engineer Signature: Bob

Distance:

Note: Report NO.:ATE20171665

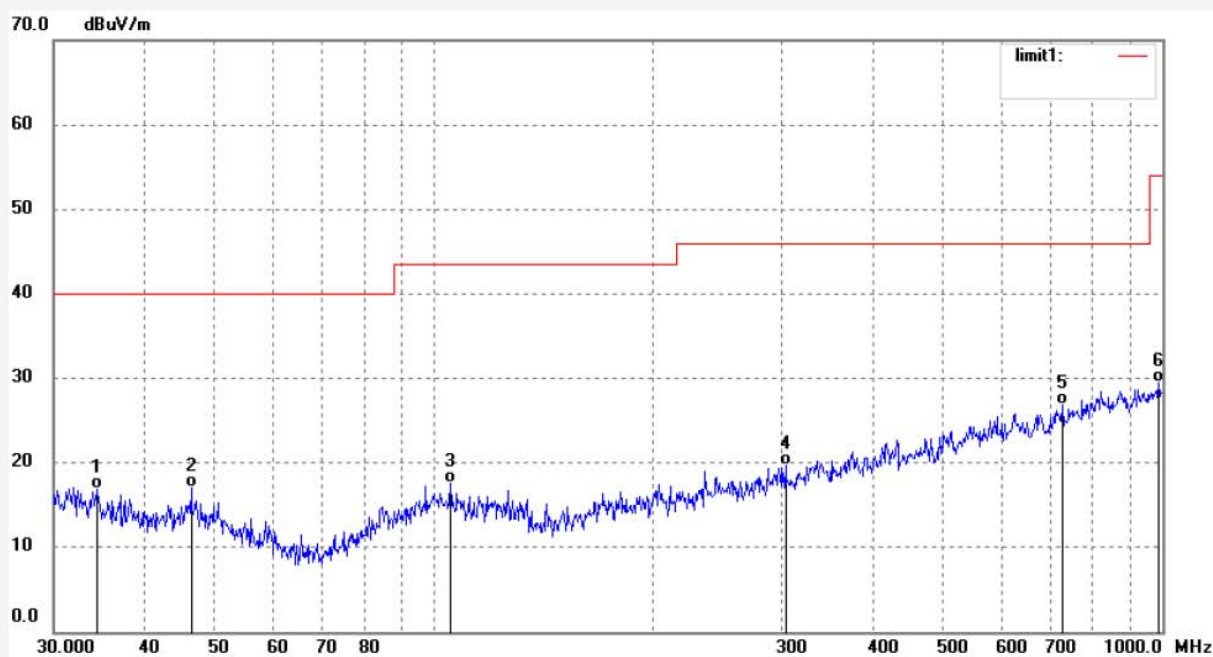

No.	Freq. (MHz)	Reading (dBuV/m)	Factor (dB)	Result (dBuV/m)	Limit (dBuV/m)	Margin (dB)	Detector	Height (cm)	Degree (deg.)	Remark
1	34.4059	35.17	-18.24	16.93	40.00	-23.07	QP	200	156	
2	46.3806	36.69	-19.64	17.05	40.00	-22.95	QP	200	302	
3	105.1667	36.96	-19.39	17.57	43.50	-25.93	QP	200	214	
4	303.8851	36.26	-16.54	19.72	46.00	-26.28	QP	200	45	
5	728.8971	35.25	-8.45	26.80	46.00	-19.20	QP	200	92	
6	989.5145	34.30	-4.84	29.46	54.00	-24.54	QP	200	204	

Above 1GHz

ACCURATE TECHNOLOGY CO., LTD.

 F1,Bldg,A,Changyuan New Material Port Keyuan Rd,
 Science & Industry Park,Nanshan Shenzhen,P.R.China

Site: 1# Chamber

Tel:+86-0755-26503290

Fax:+86-0755-26503396

Job No.: FRANK2018 #756

Standard: FCC PK

Test item: Radiation Test

Temp.(C)/Hum.(%) 23 C / 48 %

EUT: iWOWNfit Fitness

Mode: TX2402MHz

Model: i7A

Manufacturer: Shenzhen IWOWN Technology Co.,Ltd

Polarization: Horizontal

Power Source: DC 3.7V

Date: 18/09/14/

Time: 14/27/15

Engineer Signature: Bob

Distance: 3m

Note: Report NO.:ATE20171665

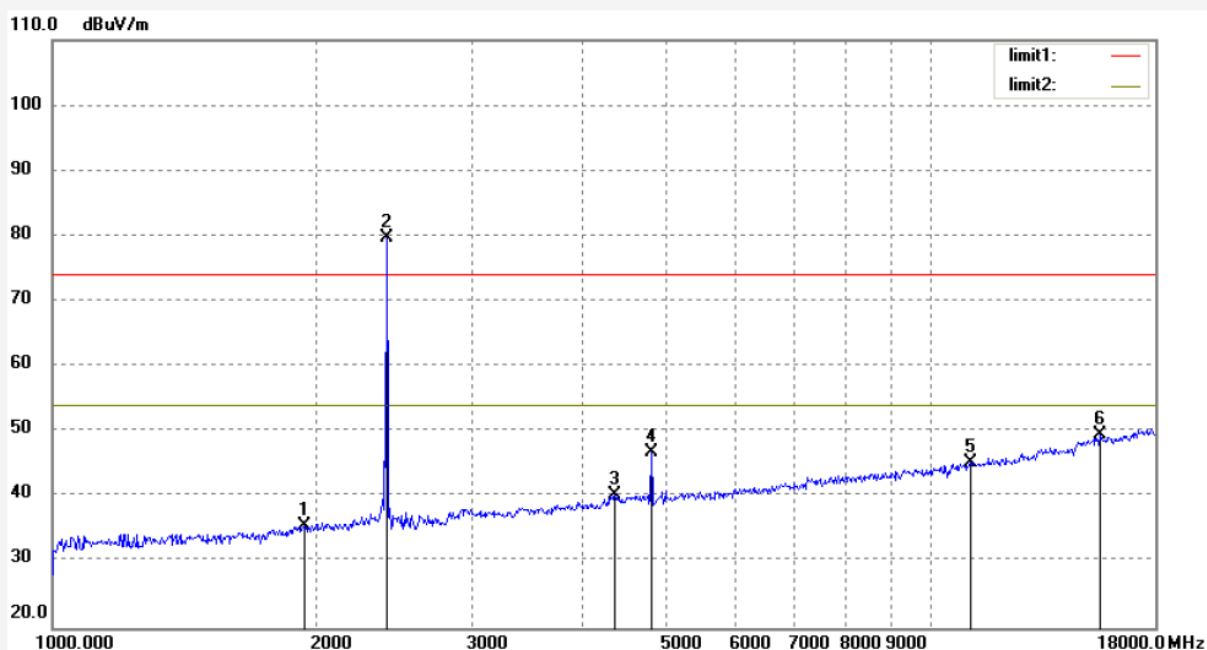

No.	Freq. (MHz)	Reading (dBuV/m)	Factor (dB)	Result (dBuV/m)	Limit (dBuV/m)	Margin (dB)	Detector	Height (cm)	Degree (deg.)	Remark
1	1938.463	37.20	-1.65	35.55	74.00	-38.45	peak	250	205	
2	2402.000	78.78	0.88	79.66			peak	250	323	
3	4367.058	35.04	5.24	40.28	74.00	-33.72	peak	200	110	
4	4804.000	39.45	7.40	46.85	74.00	-27.15	peak	250	268	
5	11076.096	27.85	17.46	45.31	74.00	-28.69	peak	200	221	
6	15577.899	-8.73	58.34	49.61	74.00	-24.39	peak	250	101	



ACCURATE TECHNOLOGY CO., LTD.

F1,Bldg,A,Changyuan New Material Port Keyuan Rd,
Science & Industry Park,Nanshan Shenzhen,P.R.China

Site: 1# Chamber

Tel:+86-0755-26503290

Fax:+86-0755-26503396

Job No.: FRANK2018 #755

Standard: FCC PK

Test item: Radiation Test

Temp.(C)/Hum.(%) 23 C / 48 %

EUT: iWOWNfit Fitness

Mode: TX2402MHz

Model: i7A

Manufacturer: Shenzhen IWOWN Technology Co.,Ltd

Polarization: Vertical

Power Source: DC 3.7V

Date: 18/09/14/

Time: 14/20/45

Engineer Signature: Bob

Distance: 3m

Note: Report NO.:ATE20171665

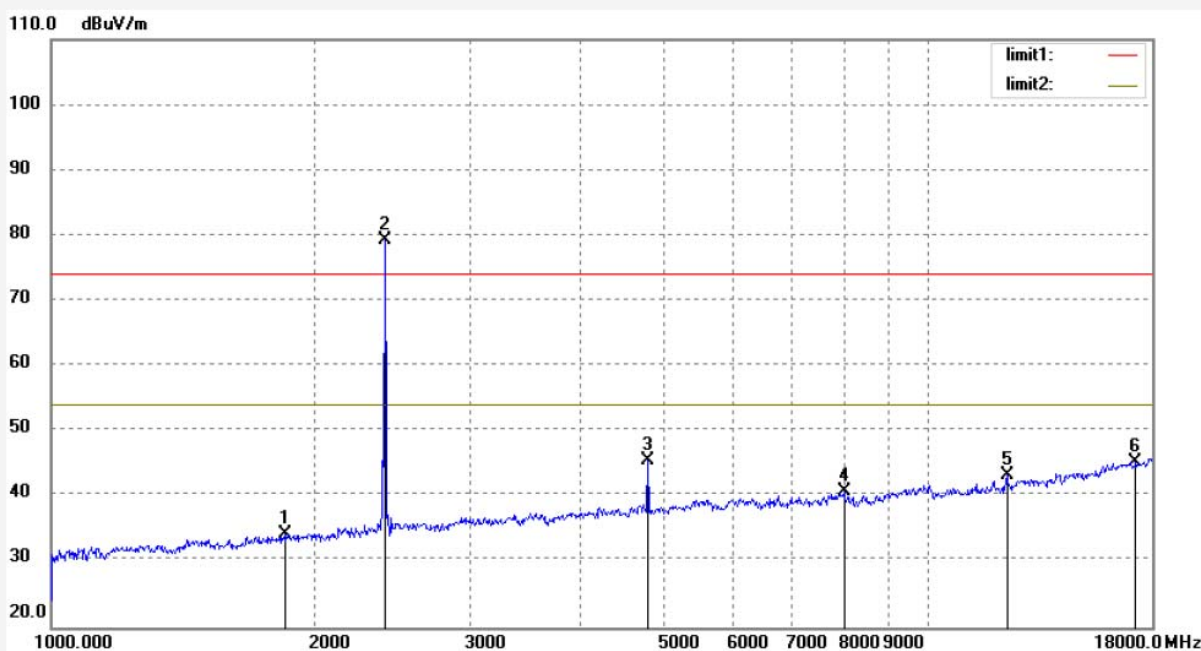

No.	Freq. (MHz)	Reading (dBuV/m)	Factor (dB)	Result (dBuV/m)	Limit (dBuV/m)	Margin (dB)	Detector	Height (cm)	Degree (deg.)	Remark
1	1845.515	36.66	-2.36	34.30	74.00	-39.70	peak	150	156	
2	2402.000	78.31	0.88	79.19			peak	150	302	
3	4804.000	38.21	7.30	45.51	74.00	-28.49	peak	150	62	
4	8013.020	25.27	15.60	40.87	74.00	-33.13	peak	150	163	
5	12290.698	-11.16	54.55	43.39	74.00	-30.61	peak	150	155	
6	17236.275	-16.69	61.99	45.30	74.00	-28.70	peak	150	302	

Job No.: FRANK2018 #754

Standard: FCC PK

Test item: Radiation Test

Temp.(C)/Hum.(%) 23 C / 48 %

EUT: iWOWNfit Fitness

Mode: TX2440MHz

Model: i7A

Manufacturer: Shenzhen IWOWN Technology Co.,Ltd

Polarization: Vertical

Power Source: DC 3.7V

Date: 18/09/14/

Time: 14/16/24

Engineer Signature: Bob

Distance: 3m

Note: Report NO.:ATE20171665

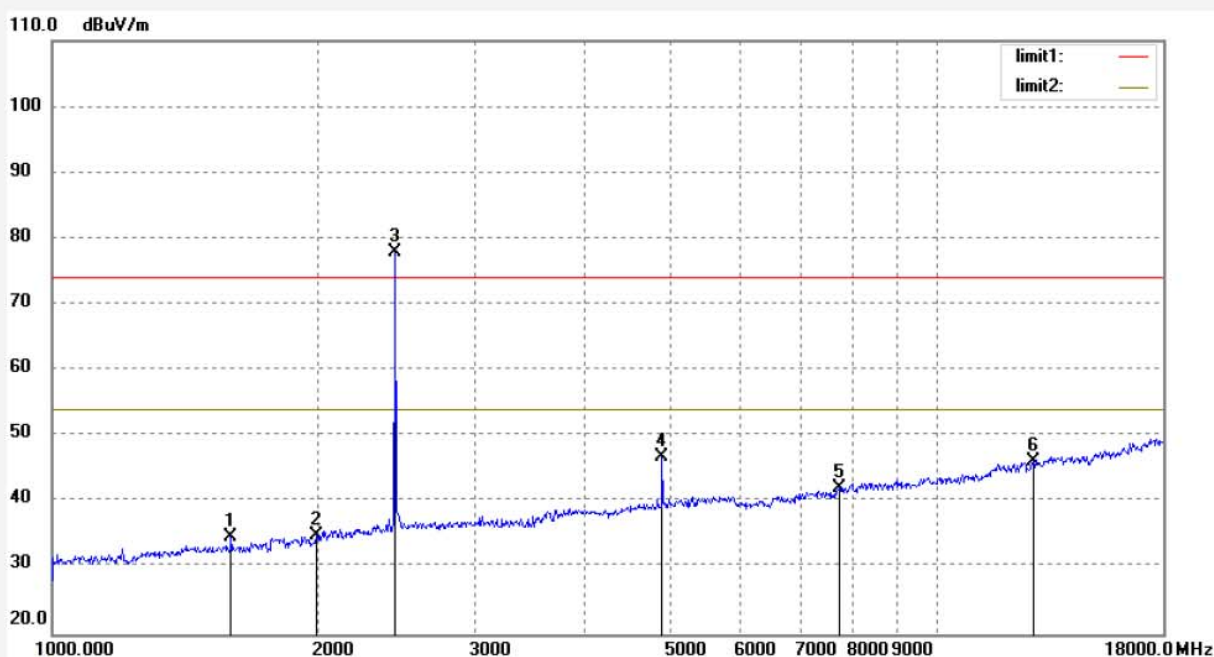

No.	Freq. (MHz)	Reading (dBuV/m)	Factor (dB)	Result (dBuV/m)	Limit (dBuV/m)	Margin (dB)	Detector	Height (cm)	Degree (deg.)	Remark
1	1592.571	39.68	-4.96	34.72	74.00	-39.28	peak	150	331	
2	1989.550	36.15	-1.09	35.06	74.00	-38.94	peak	150	102	
3	2440.000	76.82	1.06	77.88			peak	150	132	
4	4880.000	38.70	8.17	46.87	74.00	-27.13	peak	150	198	
5	7739.857	28.69	13.50	42.19	74.00	-31.81	peak	150	215	
6	12835.288	-9.45	55.65	46.20	74.00	-27.80	peak	150	302	



ACCURATE TECHNOLOGY CO., LTD.

F1,Bldg,A,Changyuan New Material Port Keyuan Rd,
Science & Industry Park,Nanshan Shenzhen,P.R.China

Site: 1# Chamber

Tel:+86-0755-26503290

Fax:+86-0755-26503396

Job No.: FRANK2018 #753

Standard: FCC PK

Test item: Radiation Test

Temp.(C)/Hum.(%) 23 C / 48 %

EUT: iWOWNfit Fitness

Mode: TX2440MHz

Model: i7A

Manufacturer: Shenzhen IWOWN Technology Co.,Ltd

Polarization: Horizontal

Power Source: DC 3.7V

Date: 18/09/14/

Time: 14/10/05

Engineer Signature: Bob

Distance: 3m

Note: Report NO.:ATE20171665

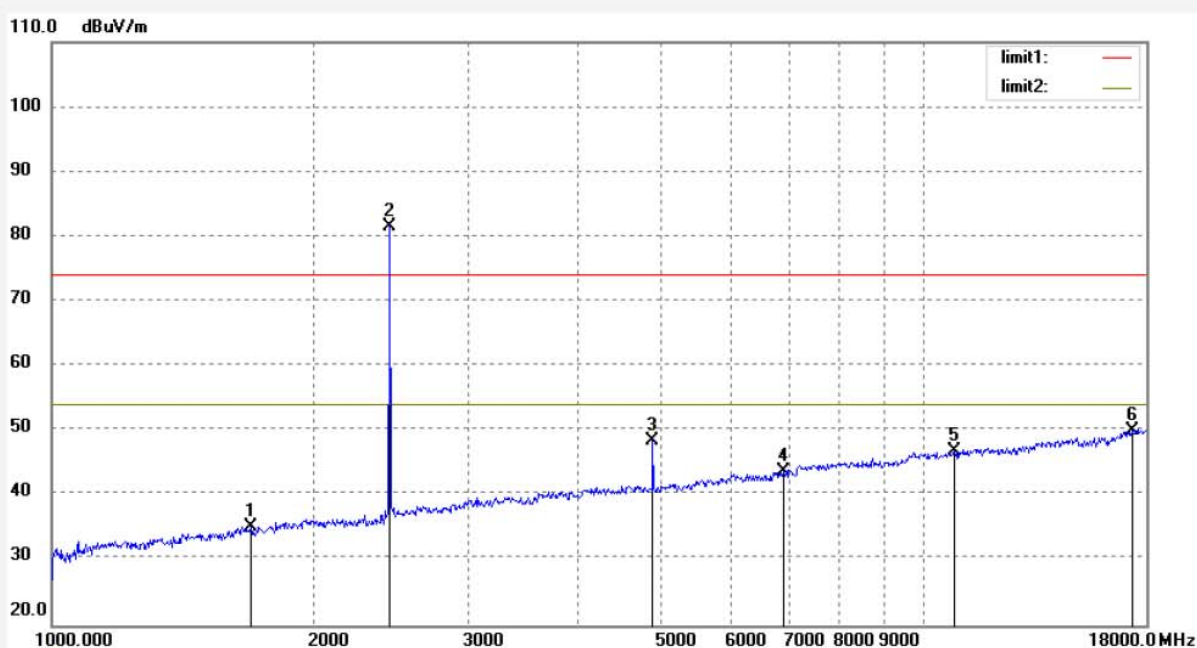

No.	Freq. (MHz)	Reading (dBuV/m)	Factor (dB)	Result (dBuV/m)	Limit (dBuV/m)	Margin (dB)	Detector	Height (cm)	Degree (deg.)	Remark
1	1692.231	38.91	-3.80	35.11	74.00	-38.89	peak	250	119	
2	2440.000	80.40	1.06	81.46			peak	250	310	
3	4880.000	40.39	8.17	48.56	74.00	-25.44	peak	250	154	
4	6914.763	31.79	11.88	43.67	74.00	-30.33	peak	250	66	
5	10822.922	30.04	16.81	46.85	74.00	-27.15	peak	250	225	
6	17336.202	-12.41	62.44	50.03	74.00	-23.97	peak	250	32	

Job No.: FRANK2018 #752
 Standard: FCC PK
 Test item: Radiation Test
 Temp.(C)/Hum.(%) 23 C / 48 %
 EUT: iWOWNfit Fitness
 Mode: TX2480MHz
 Model: i7A
 Manufacturer: Shenzhen IWOWN Technology Co.,Ltd

Polarization: Horizontal
 Power Source: DC 3.7V
 Date: 18/09/14/
 Time: 14/06/37
 Engineer Signature: Bob
 Distance: 3m

Note: Report NO.:ATE20171665

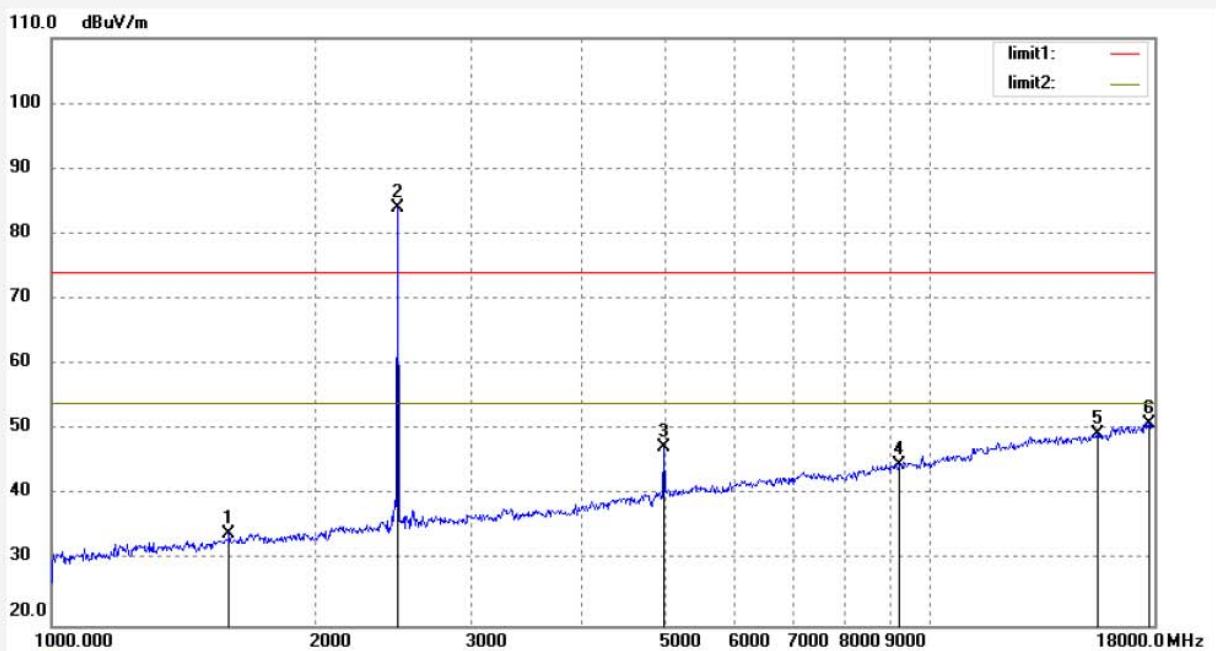

No.	Freq. (MHz)	Reading (dBuV/m)	Factor (dB)	Result (dBuV/m)	Limit (dBuV/m)	Margin (dB)	Detector	Height (cm)	Degree (deg.)	Remark
1	1592.571	38.94	-4.96	33.98	74.00	-40.02	peak	200	150	
2	2480.000	82.97	1.09	84.06			peak	250	33	
3	4960.000	38.58	8.66	47.24	74.00	-26.76	peak	200	264	
4	9232.186	29.14	15.46	44.60	74.00	-29.40	peak	200	204	
5	15488.107	-9.00	58.31	49.31	74.00	-24.69	peak	200	320	
6	17741.737	-13.56	64.60	51.04	74.00	-22.96	peak	250	148	



ACCURATE TECHNOLOGY CO., LTD.

F1,Bldg,A,Changyuan New Material Port Keyuan Rd,
Science & Industry Park,Nanshan Shenzhen,P.R.China

Site: 1# Chamber

Tel:+86-0755-26503290

Fax:+86-0755-26503396

Job No.: FRANK2018 #751

Standard: FCC PK

Test item: Radiation Test

Temp.(C)/Hum.(%) 23 C / 48 %

EUT: iWOWNfit Fitness

Mode: TX2480MHz

Model: i7A

Manufacturer: Shenzhen IWOWN Technology Co.,Ltd

Polarization: Vertical

Power Source: DC 3.7V

Date: 18/09/14/

Time: 14/02/45

Engineer Signature: Bob

Distance: 3m

Note: Report NO.:ATE20171665

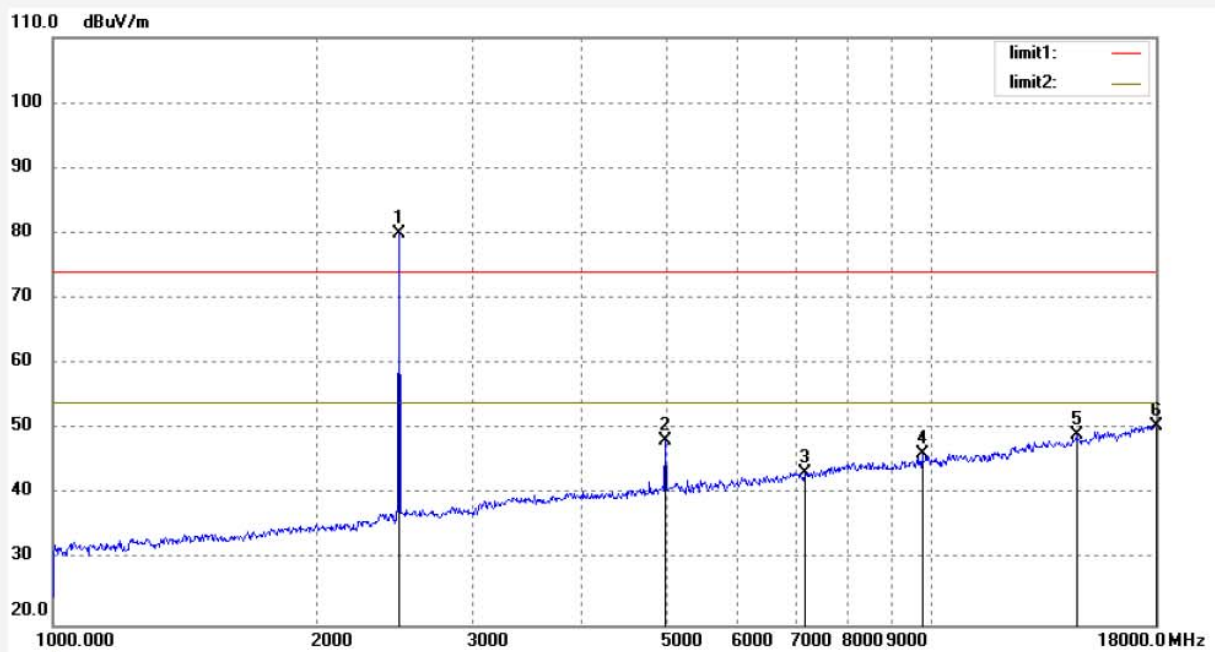

No.	Freq. (MHz)	Reading (dBuV/m)	Factor (dB)	Result (dBuV/m)	Limit (dBuV/m)	Margin (dB)	Detector	Height (cm)	Degree (deg.)	Remark
1	2480.000	78.83	1.09	79.92			peak	150	331	
2	4960.000	39.51	8.66	48.17	74.00	-25.83	peak	150	102	
3	7179.527	32.39	11.01	43.40	74.00	-30.60	peak	150	62	
4	9753.371	28.35	17.79	46.14	74.00	-27.86	peak	150	55	
5	14618.166	-11.05	60.17	49.12	74.00	-24.88	peak	150	324	
6	18000.000	-15.63	66.10	50.47	74.00	-23.53	peak	150	109	

11. ANTENNA REQUIREMENT

11.1. The Requirement

According to Section 15.203, an intentional radiator shall be designed to ensure that no antenna other than that furnished by the responsible party shall be used with the device.

11.2. Antenna Construction

Device is equipped with permanent attached antenna, which isn't displaced by other antenna. The Antenna gain of EUT is 1.72dBi. Therefore, the equipment complies with the antenna requirement of Section 15.203.

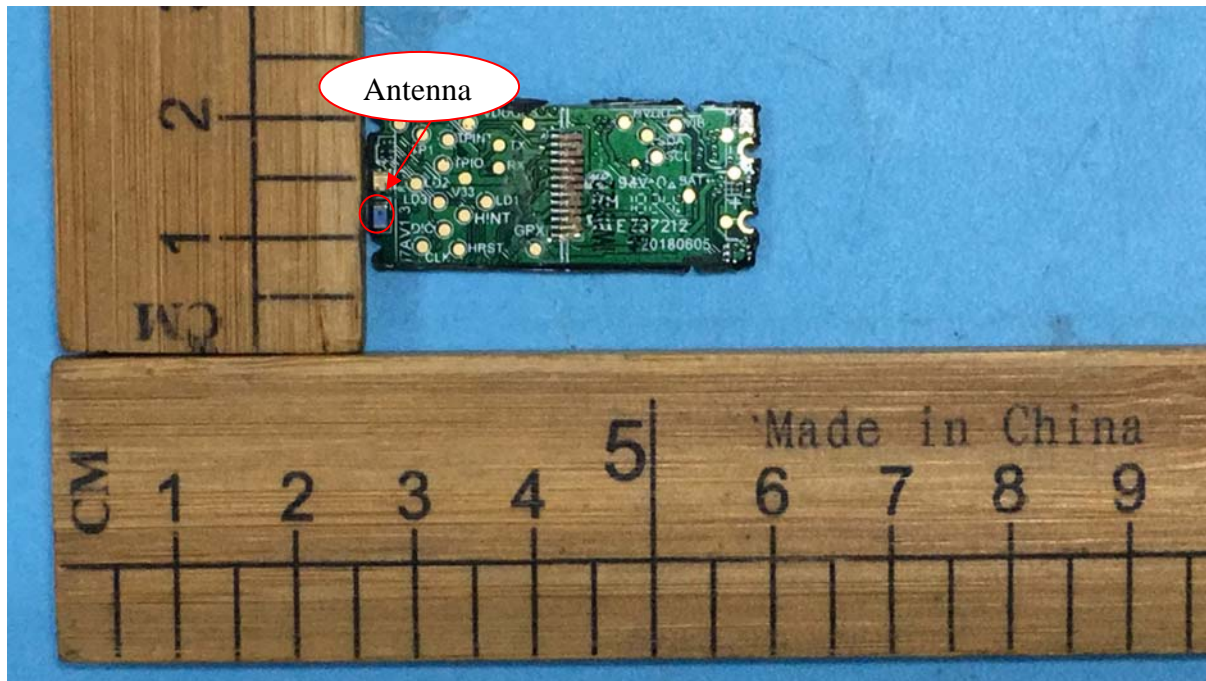

***** End of Test Report *****