

APPLICATION CERTIFICATION FCC Part 15C
On Behalf of
Legamaster International B.V.

e-Screen ETX slot-in Android box

Model No.: RK3399

FCC ID: 2AKP8-RK3399

Prepared for : Legamaster International B.V.
Address : Kwinkweerd 62, NL-7241 CW Lochem Postbus 111,
NL-7240 AC Lochem

Prepared by : Shenzhen Accurate Technology Co., Ltd.
Address : 1/F., Building A, Changyuan New Material Port,
Science & Industry Park, Nanshan District,
Shenzhen, Guangdong, P.R. China.

Tel: (0755) 26503290
Fax: (0755) 26503396

Report No. : ATE20181648
Date of Test : Sep. 06, 2018-Sep. 28, 2018
Date of Report : Sep. 29, 2018

TABLE OF CONTENTS

Description	Page
Test Report Certification	
1. GENERAL INFORMATION	5
1.1. Description of Device (EUT).....	5
1.2. Accessory and Auxiliary Equipment.....	5
1.3. Description of Test Facility	6
1.4. Measurement Uncertainty.....	6
2. MEASURING DEVICE AND TEST EQUIPMENT	7
3. OPERATION OF EUT DURING TESTING	8
3.1. Operating Mode	8
3.2. Configuration and peripherals	8
4. TEST PROCEDURES AND RESULTS	9
5. 20DB BANDWIDTH TEST.....	10
5.1. Block Diagram of Test Setup.....	10
5.2. The Requirement For Section 15.247(a)(1).....	10
5.3. EUT Configuration on Measurement	10
5.4. Operating Condition of EUT	10
5.5. Test Procedure	10
5.6. Test Result	11
6. CARRIER FREQUENCY SEPARATION TEST.....	17
6.1. Block Diagram of Test Setup.....	17
6.2. The Requirement For Section 15.247(a)(1).....	17
6.3. EUT Configuration on Measurement	17
6.4. Operating Condition of EUT	17
6.5. Test Procedure	18
6.6. Test Result	18
7. NUMBER OF HOPPING FREQUENCY TEST	24
7.1. Block Diagram of Test Setup.....	24
7.2. The Requirement For Section 15.247(a)(1)(iii).....	24
7.3. EUT Configuration on Measurement	24
7.4. Operating Condition of EUT	24
7.5. Test Procedure	24
7.6. Test Result	25
8. DWELL TIME TEST	27
8.1. Block Diagram of Test Setup.....	27
8.2. The Requirement For Section 15.247(a)(1)(iii).....	27
8.3. EUT Configuration on Measurement	27
8.4. Operating Condition of EUT	27
8.5. Test Procedure	27
8.6. Test Result	28
9. MAXIMUM PEAK OUTPUT POWER TEST	34
9.1. Block Diagram of Test Setup.....	34
9.2. The Requirement For Section 15.247(b)(1).....	34
9.3. EUT Configuration on Measurement	34
9.4. Operating Condition of EUT	34

9.5.	Test Procedure	34
9.6.	Test Result	35
10.	RADIATED EMISSION TEST	41
10.1.	Block Diagram of Test Setup.....	41
10.2.	The Limit For Section 15.247(d)	43
10.3.	Restricted bands of operation	43
10.4.	Configuration of EUT on Measurement	44
10.5.	Test Procedure	44
10.6.	Data Sample.....	45
10.7.	The Field Strength of Radiation Emission Measurement Results	45
11.	BAND EDGE COMPLIANCE TEST	64
11.1.	Block Diagram of Test Setup.....	64
11.2.	The Requirement For Section 15.247(d)	64
11.3.	EUT Configuration on Measurement	64
11.4.	Operating Condition of EUT	64
11.5.	Test Procedure	65
11.6.	Test Result	65
12.	ANTENNA REQUIREMENT.....	80
12.1.	The Requirement	80
12.2.	Antenna Construction	80

Test Report Certification

Applicant : Legamaster International B.V.
Address : Kwinkweerd 62, NL-7241 CW Lochem Postbus 111, NL-7240
AC Lochem
Manufacturer : Legamaster International B.V.
Address : Kwinkweerd 62, NL-7241 CW Lochem Postbus 111, NL-7240
AC Lochem
Product : e-Screen ETX slot-in Android box
Model No. : RK3399
Trade name : Legamaster

Measurement Procedure Used:

FCC Rules and Regulations Part 15 Subpart C Section 15.247 ANSI C63.10: 2013

The device described above is tested by SHENZHEN ACCURATE TECHNOLOGY CO. LTD to determine the maximum emission levels emanating from the device. The maximum emission levels are compared to the FCC Part 15 Subpart C Section 15.247 limits. The measurement results are contained in this test report and SHENZHEN ACCURATE TECHNOLOGY CO. LTD is assumed full responsibility for the accuracy and completeness of these measurements. Also, this report shows that the Equipment Under Test (EUT) is to be technically compliant with the FCC requirements.

This report applies to above tested sample only. This report shall not be reproduced in part without written approval of SHENZHEN ACCURATE TECHNOLOGY CO. LTD.

Date of Test : Sep. 06, 2018-Sep. 28, 2018
Date of Report : Sep. 29, 2018

Prepared by : _____
(Tim [unclear] Eng [unclear])

Approved & Authorized Signer : _____
(Sean Liu, Manager)



1. GENERAL INFORMATION

1.1. Description of Device (EUT)

EUT	:	e-Screen ETX slot-in Android box
Model Number	:	RK3399
Bluetooth version	:	BT V4.0 Dual Mode This report is for BT classic mode
Frequency Range	:	2402MHz-2480MHz
Number of Channels	:	79
Antenna Gain(Max)	:	2dBi
Antenna type	:	External Antenna
Trade Name	:	Legamaster
Rating	:	DC 12~19V
Modulation mode	:	GFSK, $\pi/4$ DQPSK, 8DPSK
Applicant Address	:	Legamaster International B.V. Kwinkweerd 62, NL-7241 CW Lochem Postbus 111, NL-7240 AC Lochem
Manufacturer Address	:	Legamaster International B.V. Kwinkweerd 62, NL-7241 CW Lochem Postbus 111, NL-7240 AC Lochem
Date of sample received	:	Sep. 06, 2018
Date of Test	:	Sep. 06, 2018-Sep. 28, 2018

1.2. Accessory and Auxiliary Equipment

PC	Manufacturer: LENOVO M/N: 4290-RT8 S/N: R9-FW93G 11/08
Adapter	Manufacturer: N/A INPUT: 100-240V 50/60Hz OUTPUT: DC 12V 5A

1.3. Description of Test Facility

EMC Lab : Recognition of accreditation by Federal Communications Commission (FCC)
The Designation Number is CN1189
The Registration Number is 708358

Listed by Innovation, Science and Economic Development Canada (ISED)
The Registration Number is 5077A-2

Accredited by China National Accreditation Service for Conformity Assessment (CNAS)
The Registration Number is CNAS L3193

Accredited by American Association for Laboratory Accreditation (A2LA)
The Certificate Number is 4297.01

Name of Firm : Shenzhen Accurate Technology Co., Ltd.
Site Location : 1/F., Building A, Changyuan New Material Port, Science & Industry Park, Nanshan District, Shenzhen, Guangdong, P.R. China

1.4. Measurement Uncertainty

Conducted Emission Expanded Uncertainty = 2.23dB, k=2

Power Disturbance Expanded Uncertainty = 2.92 dB, k=2

Radiated emission expanded uncertainty (9kHz-30MHz) = 3.08dB, k=2

Radiated emission expanded uncertainty (30MHz-1000MHz) = 4.42dB, k=2

Radiated emission expanded uncertainty (Above 1GHz) = 4.06dB, k=2

2. MEASURING DEVICE AND TEST EQUIPMENT

Table 1: List of Test and Measurement Equipment

Kind of equipment	Manufacturer	Type	S/N	Calibrated dates	Calibrated until
EMI Test Receiver	Rohde&Schwarz	ESCS30	100307	Jan. 06, 2018	Jan. 05, 2019
EMI Test Receiver	Rohde&Schwarz	ESPI3	101526/003	Jan. 06, 2018	Jan. 05, 2019
Spectrum Analyzer	Agilent	E7405A	MY45115511	Jan. 06, 2018	Jan. 05, 2019
Pre-Amplifier	Rohde&Schwarz	CBLU118354 0-01	3791	Jan. 06, 2018	Jan. 05, 2019
Loop Antenna	Schwarzbeck	FMZB1516	1516131	Jan. 06, 2018	Jan. 05, 2019
Bilog Antenna	Schwarzbeck	VULB9163	9163-323	Jan. 06, 2018	Jan. 05, 2019
Horn Antenna	Schwarzbeck	BBHA9120D	9120D-655	Jan. 06, 2018	Jan. 05, 2019
Horn Antenna	Schwarzbeck	BBHA9170	9170-359	Jan. 06, 2018	Jan. 05, 2019
LISN	Rohde&Schwarz	ESH3-Z5	100305	Jan. 06, 2018	Jan. 05, 2019
LISN	Schwarzbeck	NSLK8126	8126431	Jan. 06, 2018	Jan. 05, 2019
Highpass Filter	Wainwright Instruments	WHKX3.6/18 G-10SS	N/A	Jan. 06, 2018	Jan. 05, 2019
Band Reject Filter	Wainwright Instruments	WRCG2400/2 485-2375/2510 -60/11SS	N/A	Jan. 06, 2018	Jan. 05, 2019

3. OPERATION OF EUT DURING TESTING

3.1. Operating Mode

The mode is used: Transmitting mode

Low Channel: 2402MHz

Middle Channel: 2441MHz

High Channel: 2480MHz

Hopping

3.2. Configuration and peripherals

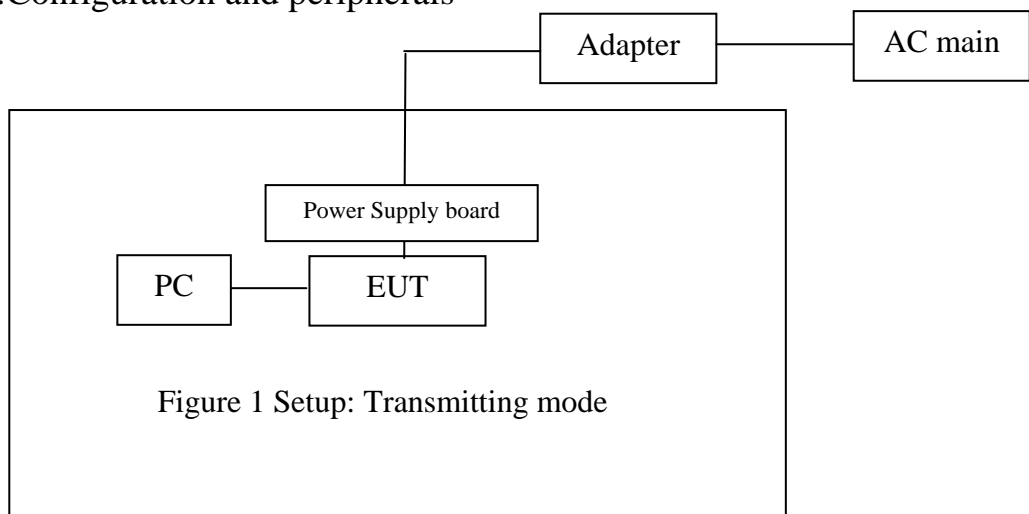

(EUT: e-Screen ETX slot-in Android box)

4. TEST PROCEDURES AND RESULTS

FCC Rules	Description of Test	Result
Section 15.207	Conducted Emission Test	N/A
Section 15.247(a)(1)	20dB Bandwidth Test	Compliant
Section 15.247(a)(1)	Carrier Frequency Separation Test	Compliant
Section 15.247(a)(1)(iii)	Number Of Hopping Frequency Test	Compliant
Section 15.247(a)(1)(iii)	Dwell Time Test	Compliant
Section 15.247(b)(1)	Maximum Peak Output Power Test	Compliant
Section 15.247(d) Section 15.209	Radiated Emission Test	Compliant
Section 15.247(d)	Band Edge Compliance Test	Compliant
Section 15.203	Antenna Requirement	Compliant

Note: The power supply mode of the EUT is DC 12-19V, According to the FCC standard requirements, conducted emission is not applicable.

5. 20DB BANDWIDTH TEST

5.1. Block Diagram of Test Setup

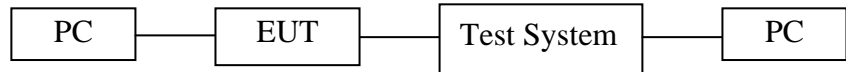

(EUT: e-Screen ETX slot-in Android box)

5.2. The Requirement For Section 15.247(a)(1)

Section 15.247(a)(1): Frequency hopping systems shall have hopping channel carrier frequencies separated by a minimum of 25 kHz or the 20 dB bandwidth of the hopping channel, whichever is greater.

5.3. EUT Configuration on Measurement

The equipment are installed on the emission measurement to meet the commission requirements and operating regulations in a manner which tends to maximize its emission characteristics in normal application.

5.4. Operating Condition of EUT

5.4.1. Setup the EUT and simulator as shown as Section 5.1.

5.4.2. Turn on the power of all equipment.

5.4.3. Let the EUT work in TX (Hopping off) modes measure it. The transmit frequency are 2402-2480MHz. We select 2402MHz, 2441MHz, and 2480MHz TX frequency to transmit.

5.5. Test Procedure

5.5.1. The transmitter output was connected to the spectrum analyzer through a low loss cable.

5.5.2. Set RBW of spectrum analyzer to 100 kHz and VBW to 300 kHz.

5.5.3. The 20dB bandwidth is defined as the total spectrum the power of which is higher than peak power minus 20dB.

5.6. Test Result

Channel	Frequency (MHz)	GFSK 20dB Bandwidth (MHz)	$\Pi/4$ DQPSK 20dB Bandwidth (MHz)	8DPSK 20dB Bandwidth (MHz)	Result
Low	2402	1.140	1.392	1.356	Pass
Middle	2441	1.140	1.392	1.360	Pass
High	2480	1.134	1.392	1.356	Pass

The spectrum analyzer plots are attached as below.

GFSK Mode

Low channel

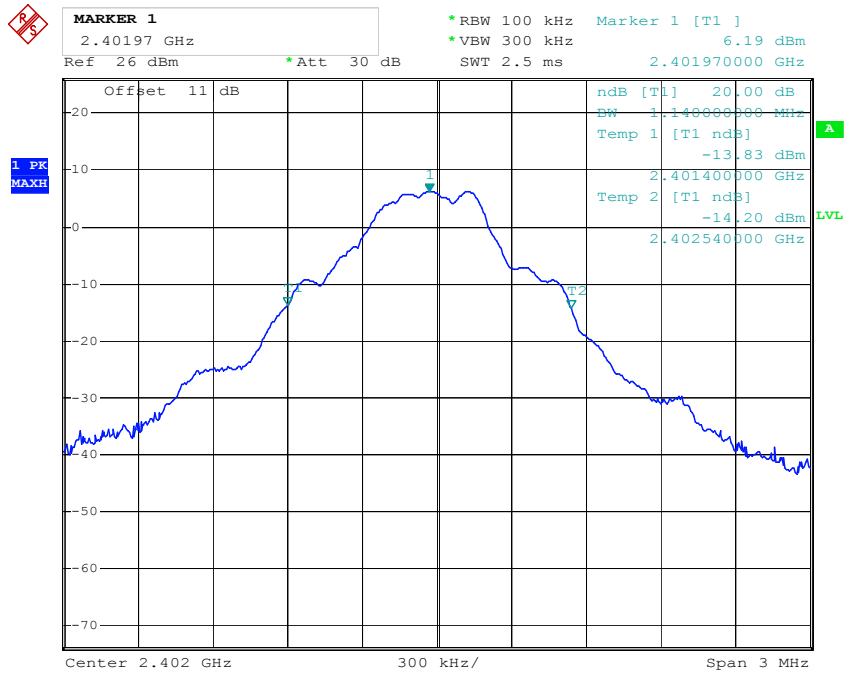

Comment A:
Date: 6.SEP.2018 16:27:35

Middle channel

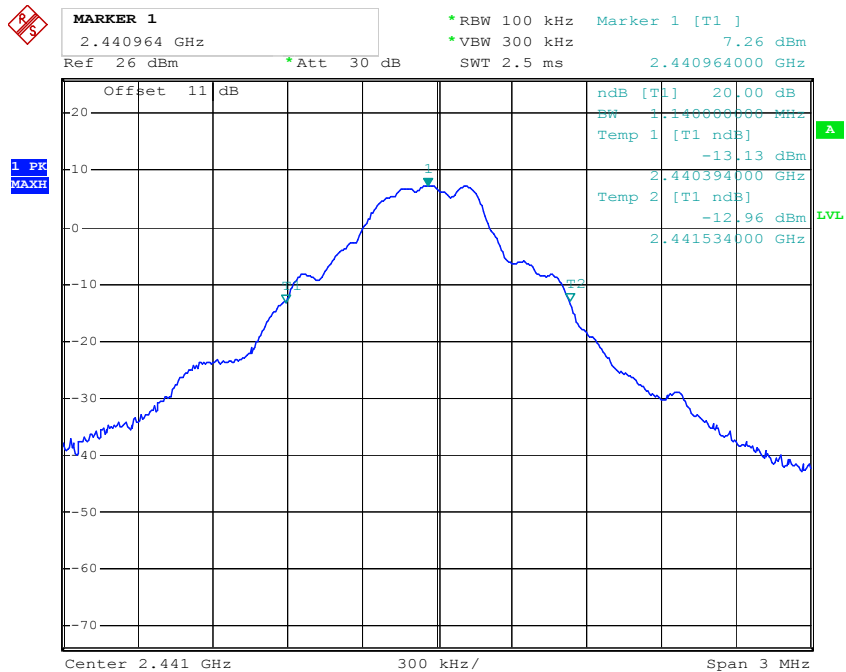

Comment A:
Date: 6.SEP.2018 16:29:28

High channel

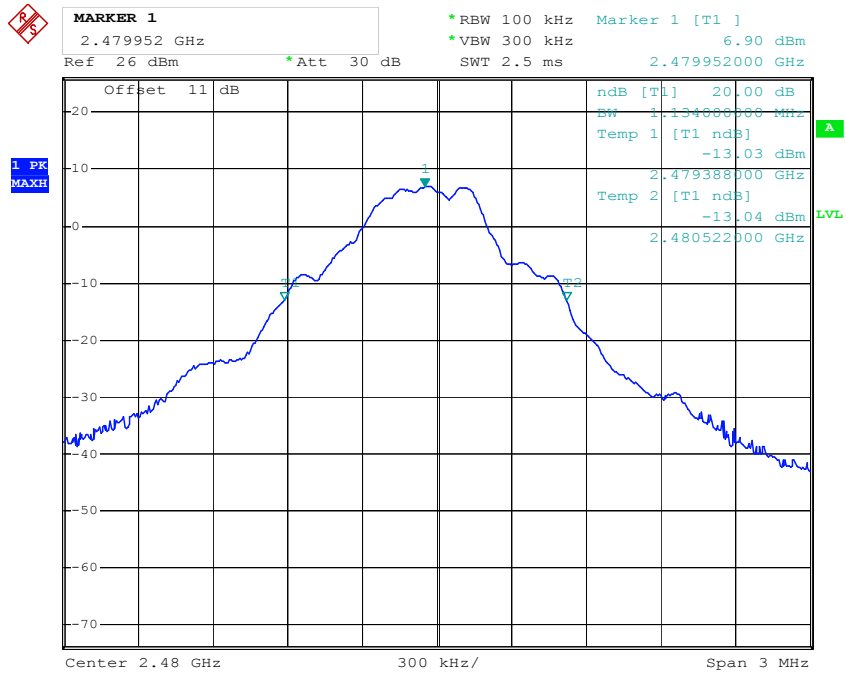

Comment A:
Date: 6.SEP.2018 16:30:42

Π/4-DQPSK Mode

Low channel

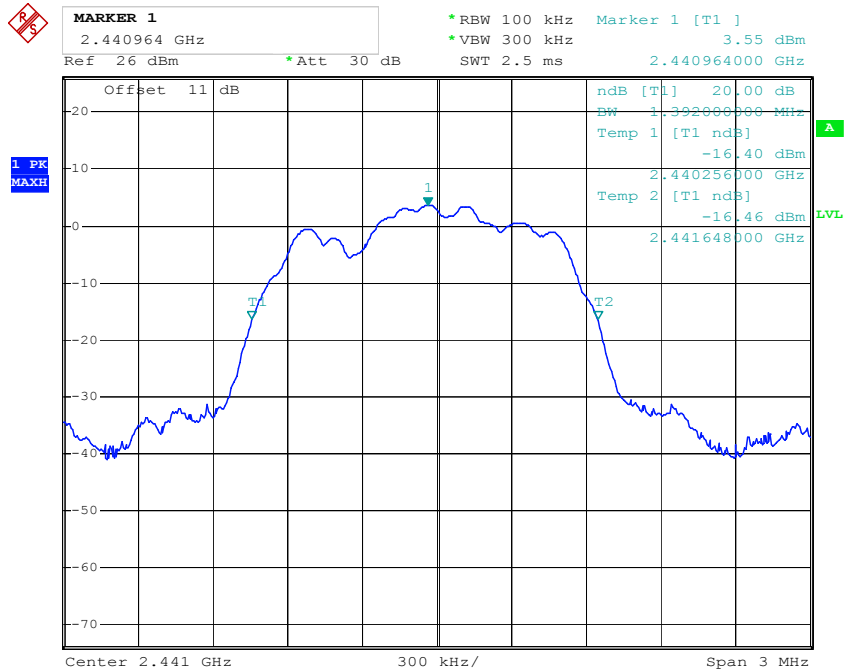

Comment A:
Date: 6.SEP.2018 16:25:03

Middle channel

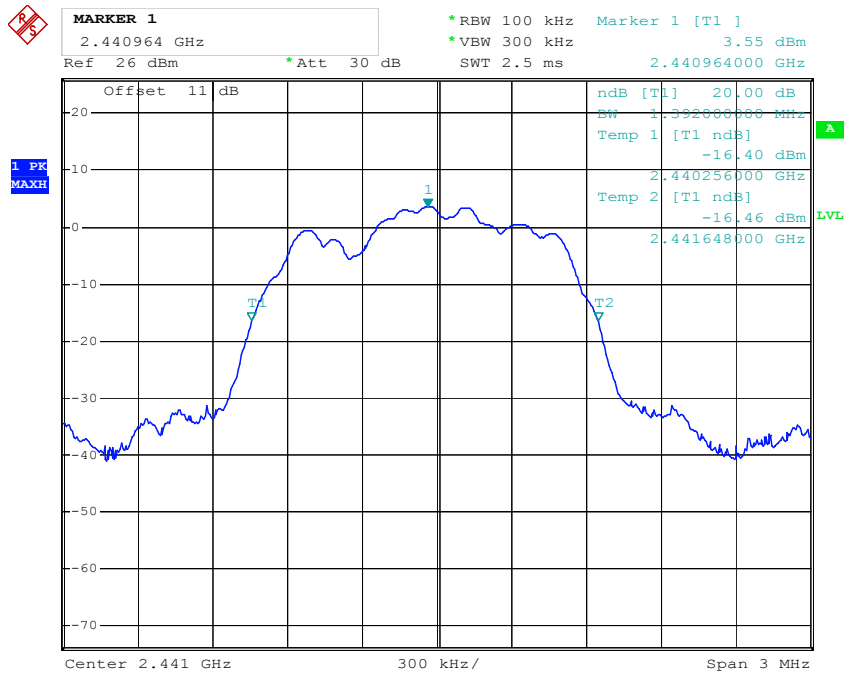

Comment A:
Date: 6.SEP.2018 16:25:03

High channel

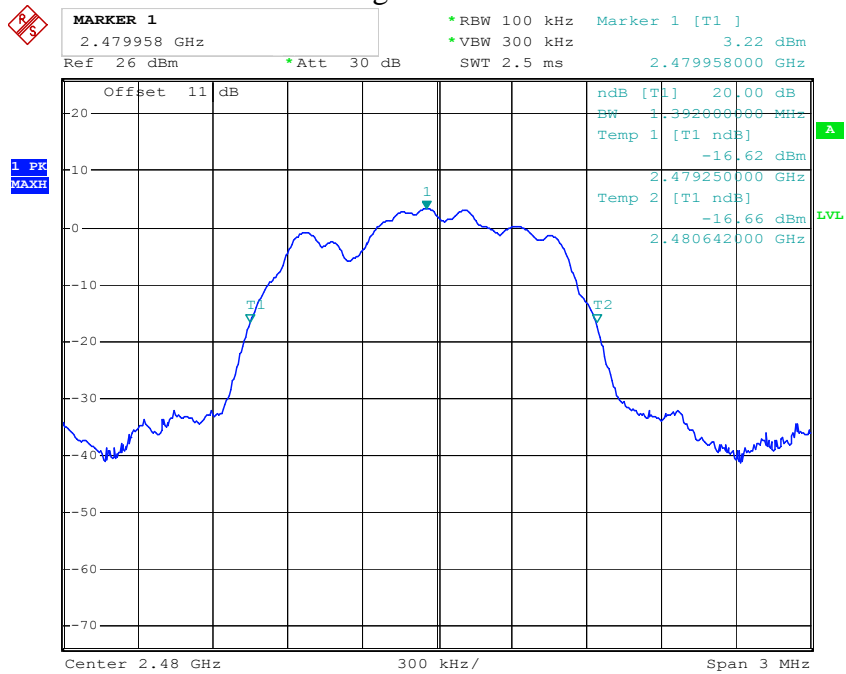

Comment A:
Date: 6.SEP.2018 16:23:51

8DPSK Mode

Low channel

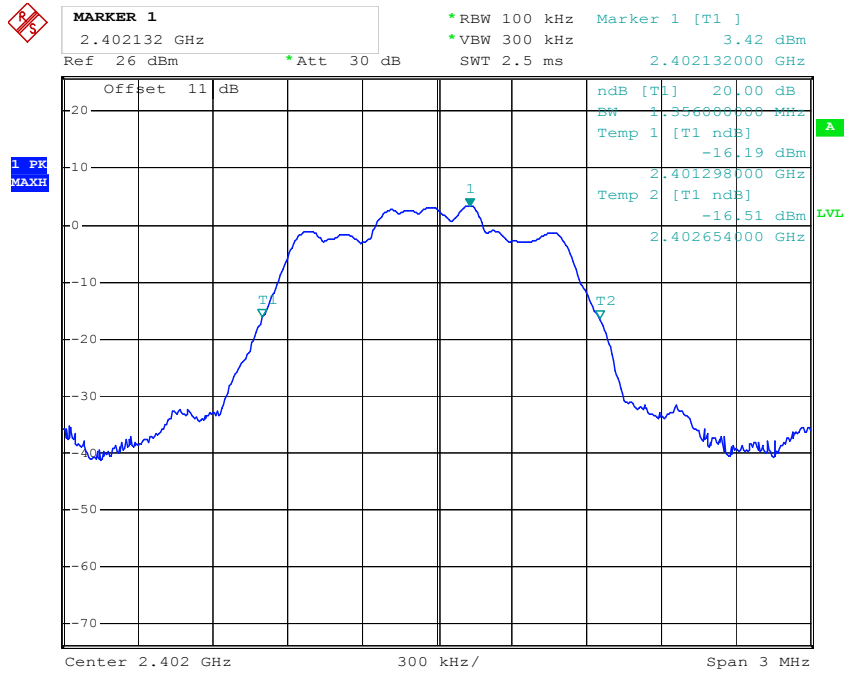

Comment A:
Date: 6.SEP.2018 16:17:53

Middle channel

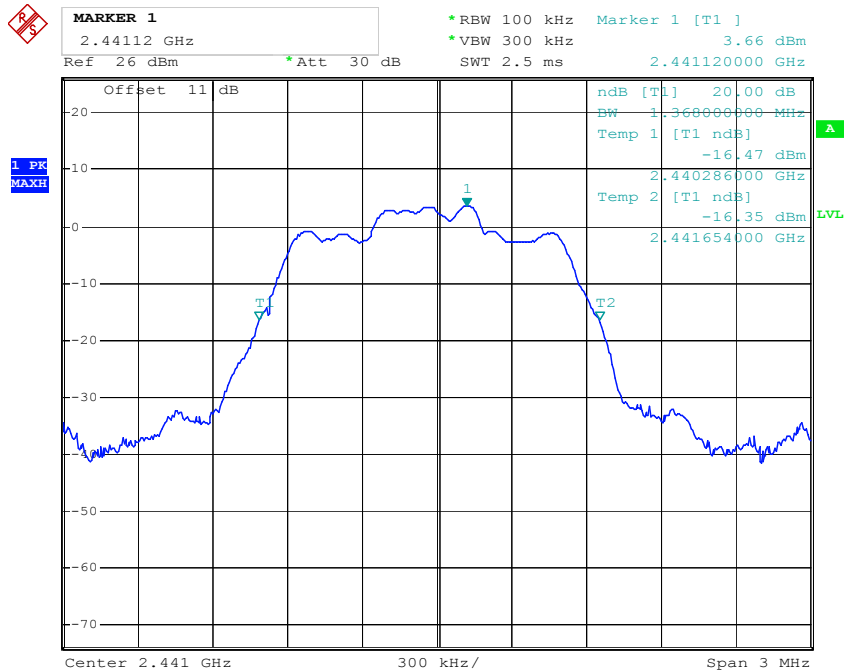

Comment A:
Date: 6.SEP.2018 16:20:34

High channel

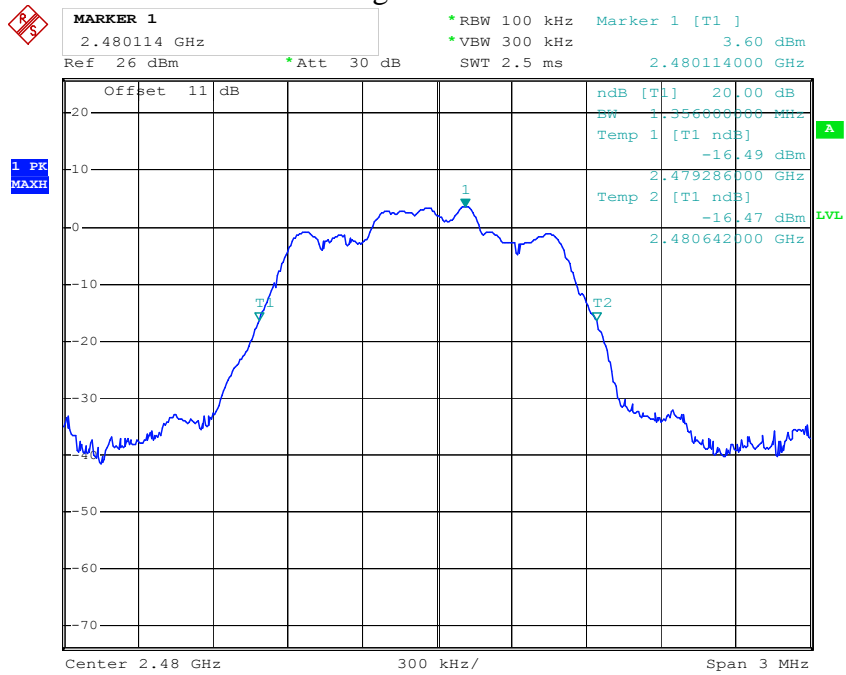

Comment A:
 Date: 6.SEP.2018 16:22:24

6. CARRIER FREQUENCY SEPARATION TEST

6.1. Block Diagram of Test Setup

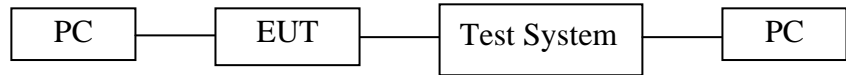

(EUT: e-Screen ETX slot-in Android box)

6.2. The Requirement For Section 15.247(a)(1)

Section 15.247(a)(1): Frequency hopping systems shall have hopping channel carrier frequencies separated by a minimum of 25 kHz or the 20 dB bandwidth of the hopping channel, whichever is greater. Alternatively, frequency hopping systems operating in the 2400-2483.5 MHz band may have hopping channel carrier frequencies that are separated by 25 kHz or two-thirds of the 20 dB bandwidth of the hopping channel, whichever is greater, provided the systems operate with an output power no greater than 125 mW. The system shall hop to channel frequencies that are selected at the system hopping rate from a pseudorandomly ordered list of hopping frequencies. Each frequency must be used equally on the average by each transmitter. The system receivers shall have input bandwidths that match the hopping channel bandwidths of their corresponding transmitters and shall shift frequencies in synchronization with the transmitted signals.

6.3. EUT Configuration on Measurement

The equipment are installed on the emission measurement to meet the commission requirements and operating regulations in a manner which tends to maximize its emission characteristics in normal application.

6.4. Operating Condition of EUT

6.4.1. Setup the EUT and simulator as shown as Section 6.1.

6.4.2. Turn on the power of all equipment.

6.4.3. Let the EUT work in TX (Hopping on) modes measure it. The transmit frequency are 2402-2480MHz. We select 2402MHz, 2441MHz, and 2480MHz TX frequency to transmit.

6.5. Test Procedure

6.5.1. The transmitter output was connected to the spectrum analyzer through a low loss cable.

6.5.2. Set RBW of spectrum analyzer to 30 kHz and VBW to 100 kHz. Adjust Span to 2MHz.

6.5.3. Set the adjacent channel of the EUT Maxhold another trace.

6.5.4. Measurement the channel separation

6.6. Test Result

GFSK

Channel	Frequency (MHz)	Channel Separation(MHz)	Limit (MHz)	Result
Low	2402	1.002	25KHz or 0.760MHz	PASS
	2403			
Middle	2440	1.002	25KHz or 0.756MHz	PASS
	2441			
High	2479	1.002	25KHz or 0.756MHz	PASS
	2480			

Π/4 DQPSK

Channel	Frequency (MHz)	Channel Separation(MHz)	Limit (MHz)	Result
Low	2402	1.008	25KHz or 0.928MHz	PASS
	2403			
Middle	2440	1.002	25KHz or 0.928MHz	PASS
	2441			
High	2479	1.002	25KHz or 0.928MHz	PASS
	2480			

8DPSK

Channel	Frequency (MHz)	Channel Separation(MHz)	Limit (MHz)	Result
Low	2402	1.008	25KHz or 0.904MHz	PASS
	2403			
Middle	2440	1.002	25KHz or 0.907MHz	PASS
	2441			
High	2479	1.002	25KHz or 0.904MHz	PASS
	2480			

The spectrum analyzer plots are attached as below.

GFSK Mode

Low channel

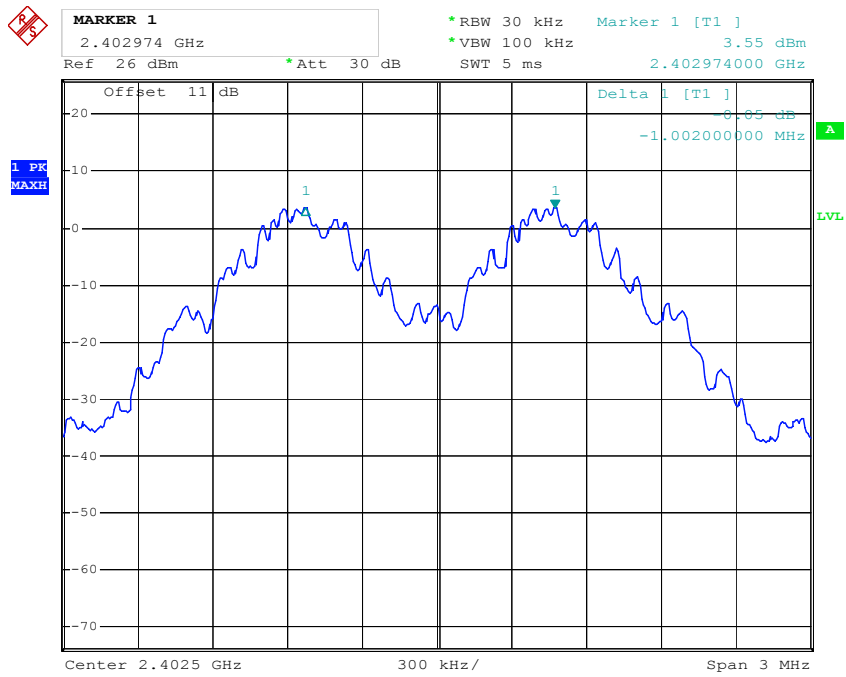

Comment A:
 Date: 6.SEP.2018 16:33:14

Middle channel

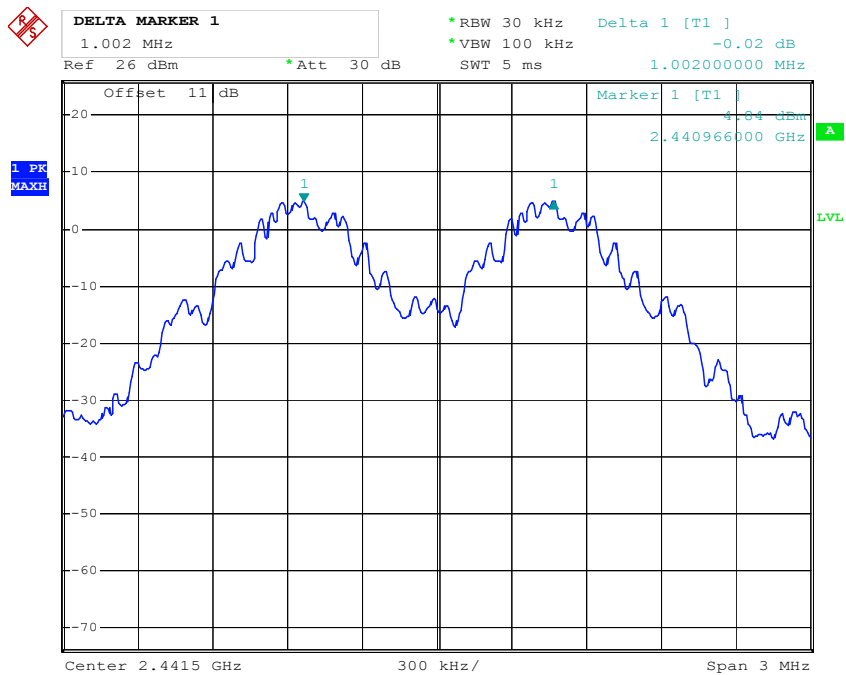

Comment A:
 Date: 6.SEP.2018 16:35:07

High channel

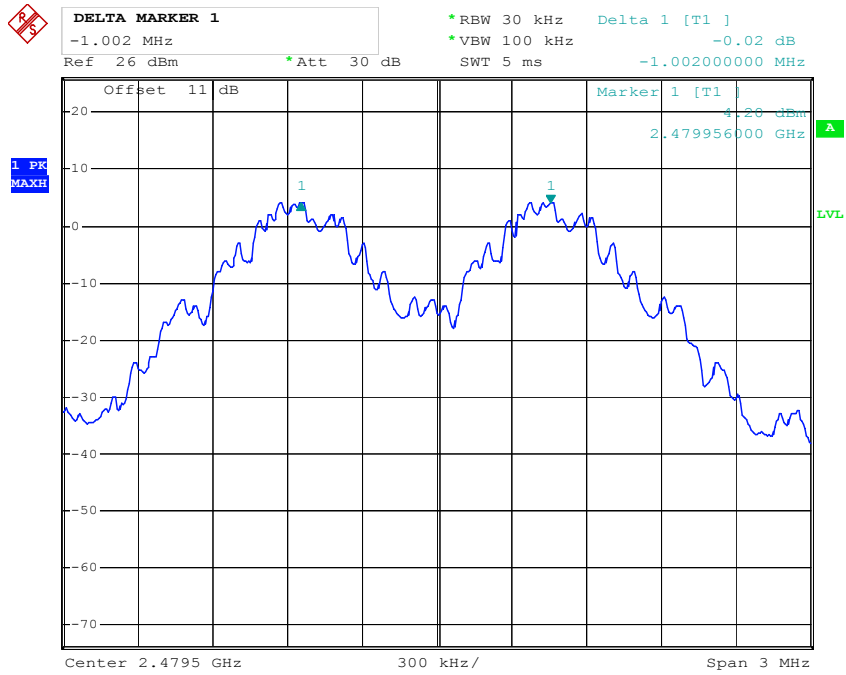

Comment A:
Date: 6.SEP.2018 16:37:04

Π/4 DQPSK Mode

Low channel

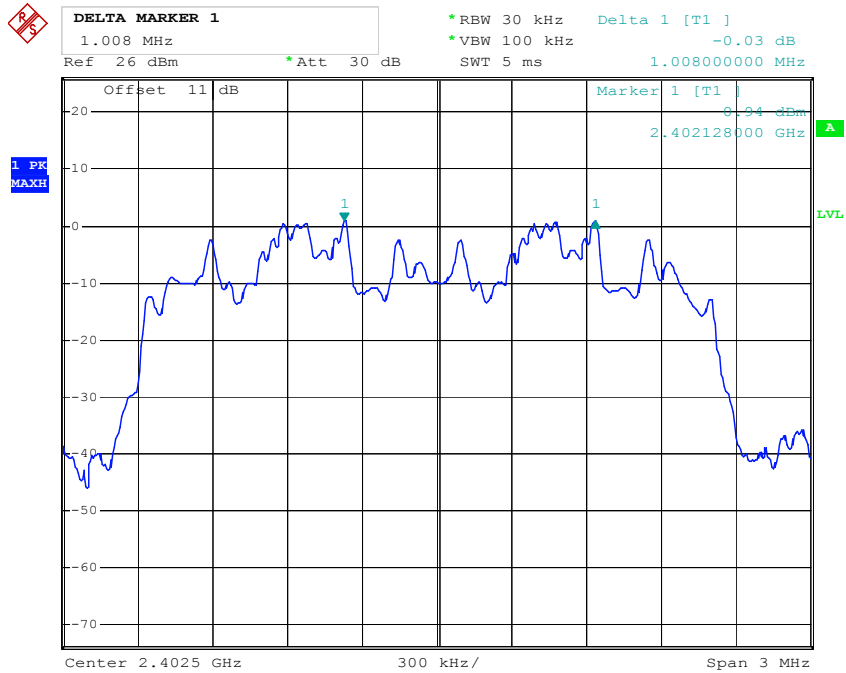

Comment A:
Date: 6.SEP.2018 16:43:15

Middle channel

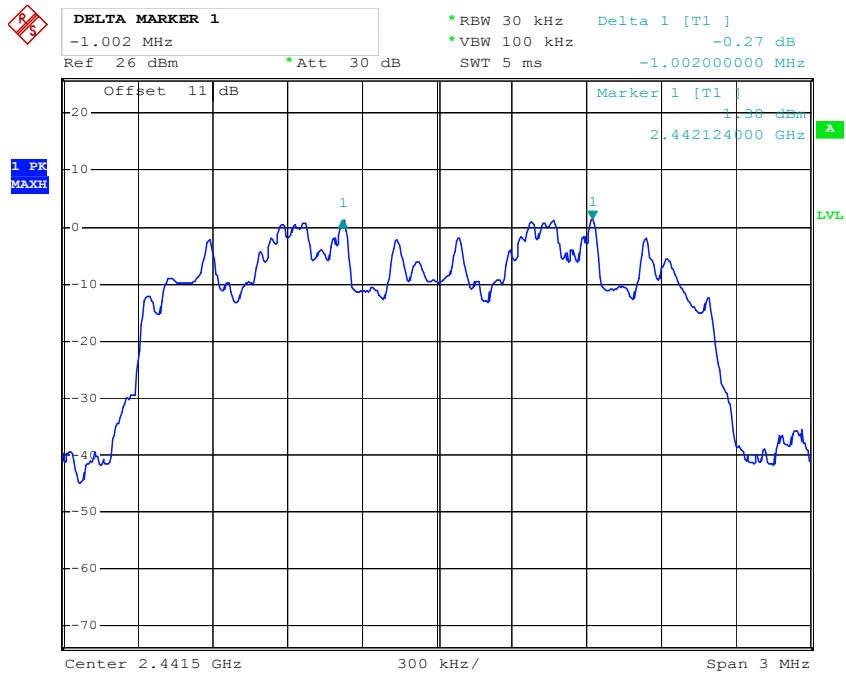

Comment A:
Date: 6.SEP.2018 16:41:21

High channel

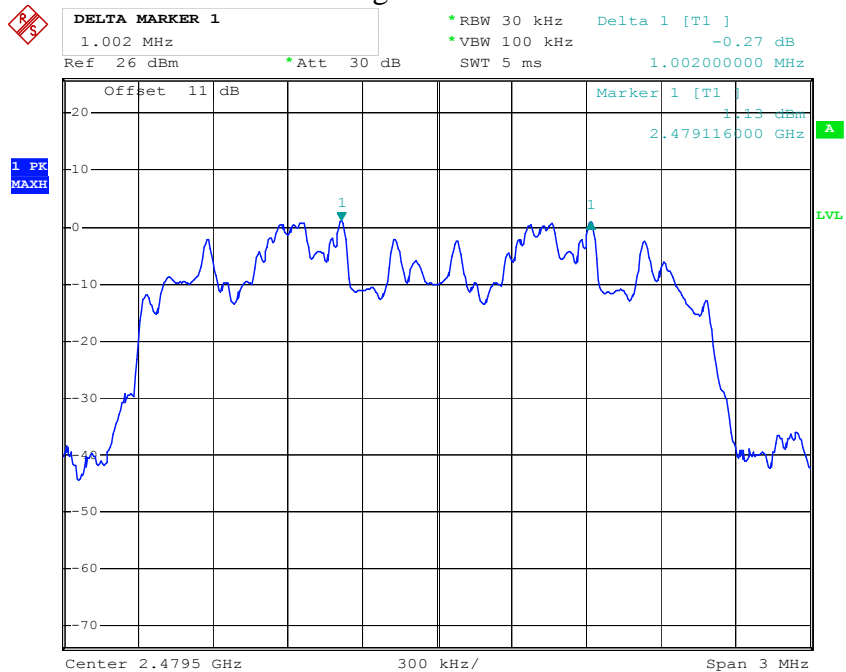

Comment A:
Date: 6.SEP.2018 16:39:40

8DPSK Mode

Low channel

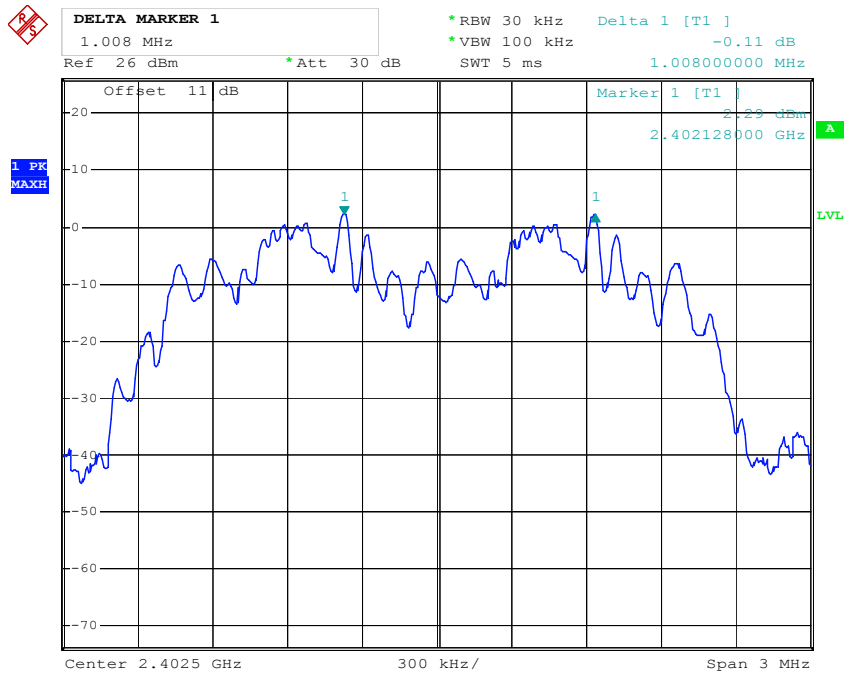

Comment A:
 Date: 6.SEP.2018 16:44:55

Middle channel

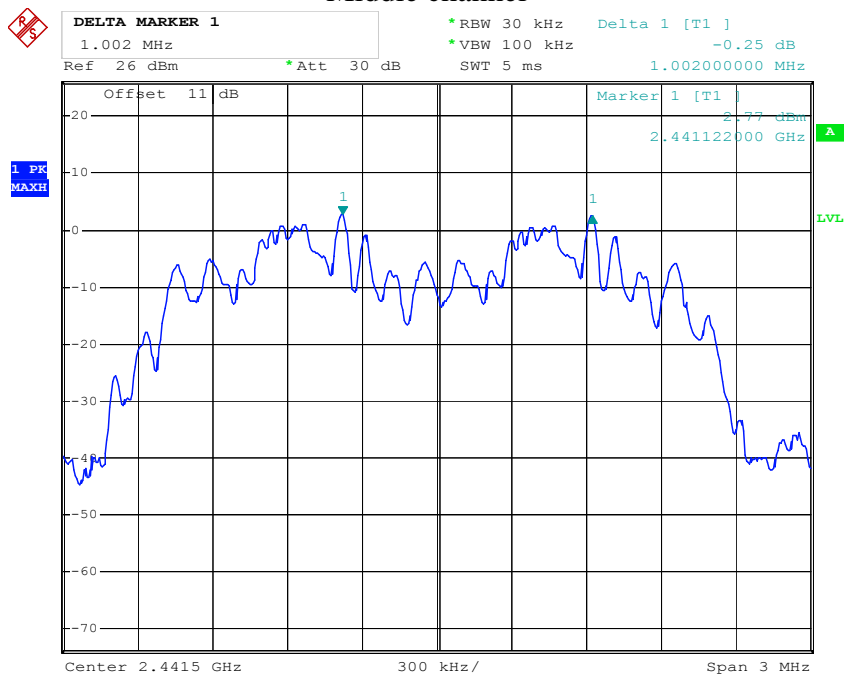

Comment A:
 Date: 6.SEP.2018 16:47:22

High channel

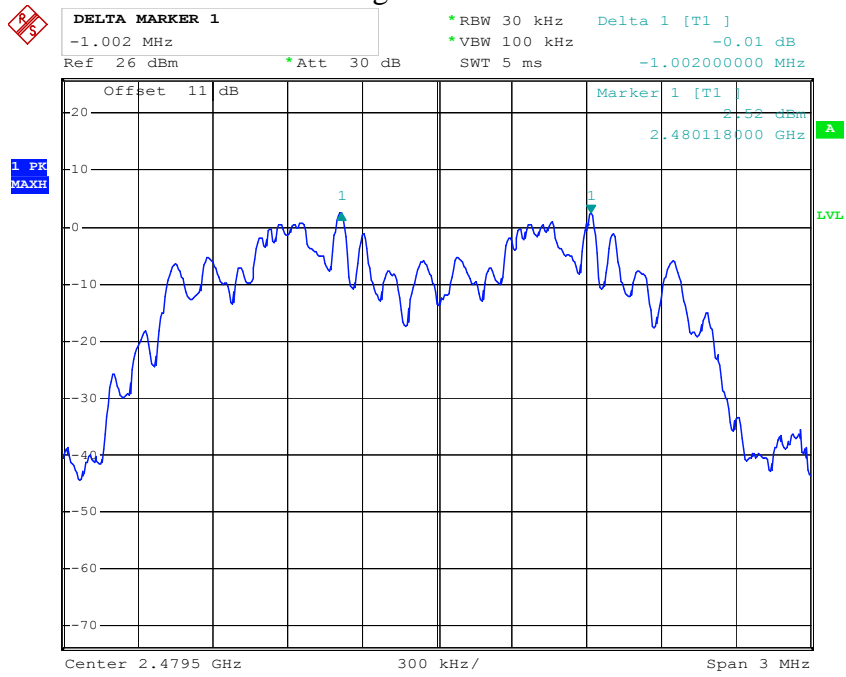

Comment A:
Date: 6.SEP.2018 16:48:57

7. NUMBER OF HOPPING FREQUENCY TEST

7.1. Block Diagram of Test Setup



(EUT: e-Screen ETX slot-in Android box)

7.2. The Requirement For Section 15.247(a)(1)(iii)

Section 15.247(a)(1)(iii): Frequency hopping systems in the 2400-2483.5 MHz band shall use at least 15 channels.

7.3. EUT Configuration on Measurement

The equipment are installed on the emission measurement to meet the commission requirements and operating regulations in a manner which tends to maximize its emission characteristics in normal application.

7.4. Operating Condition of EUT

7.4.1. Setup the EUT and simulator as shown as Section 7.1.

7.4.2. Turn on the power of all equipment.

7.4.3. Let the EUT work in TX (Hopping on) modes measure it.

7.5. Test Procedure

7.5.1. The transmitter output was connected to the spectrum analyzer through a low loss cable.

7.5.2. Set the spectrum analyzer as Span=83.5MHz, RBW=100 kHz, VBW=300 kHz.

7.5.3. Max hold, view and count how many channel in the band.

7.6.Test Result

Total number of hopping channel	Measurement result(CH)	Limit(CH)
	79	≥ 15

The spectrum analyzer plots are attached as below.

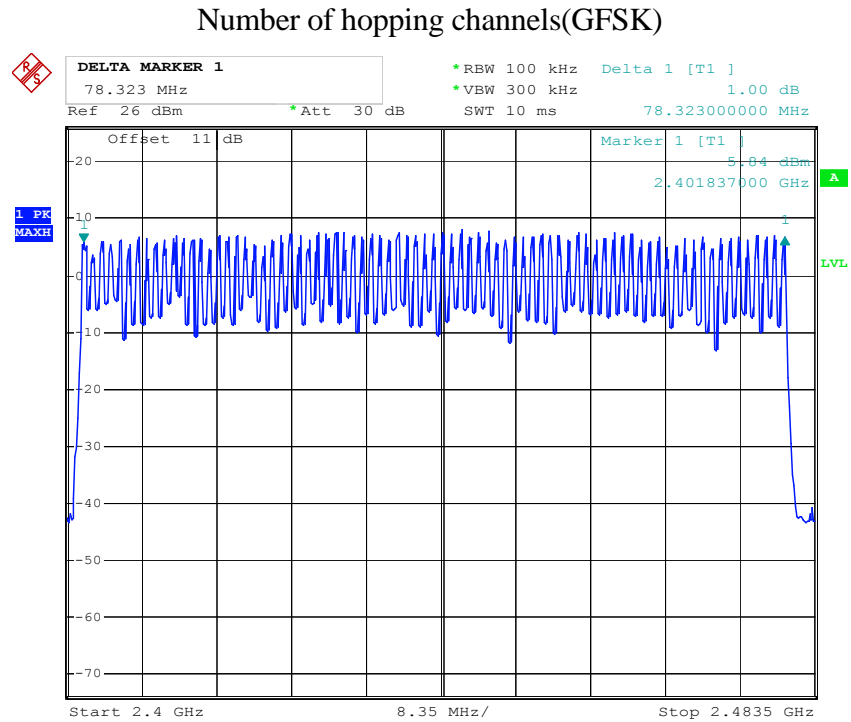

Comment A:
 Date: 6.SEP.2018 16:57:02

Number of hopping channels($\Pi/4$ DQPSK)

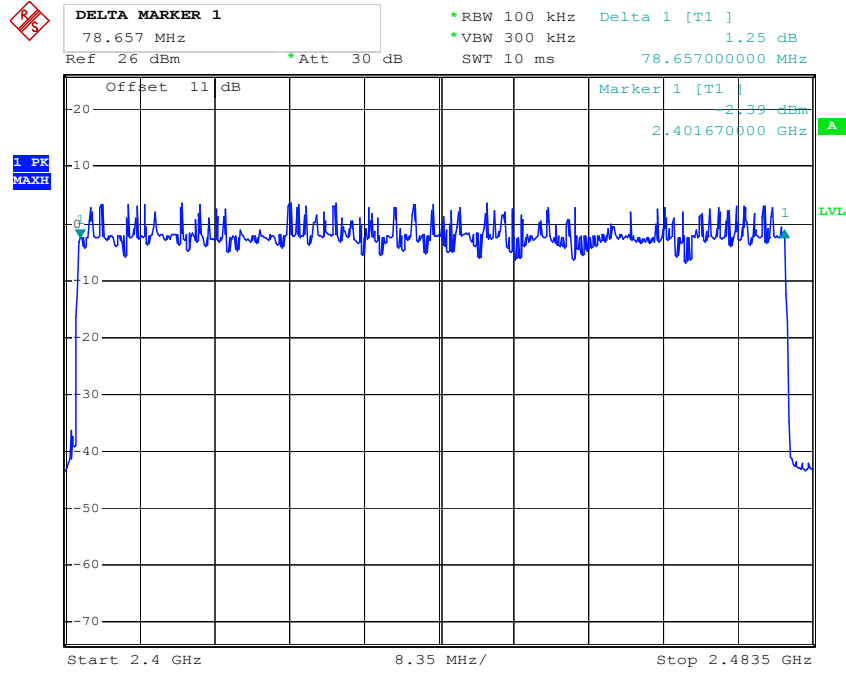

Comment A:
 Date: 6.SEP.2018 16:54:29

Number of hopping channels(8DPSK)

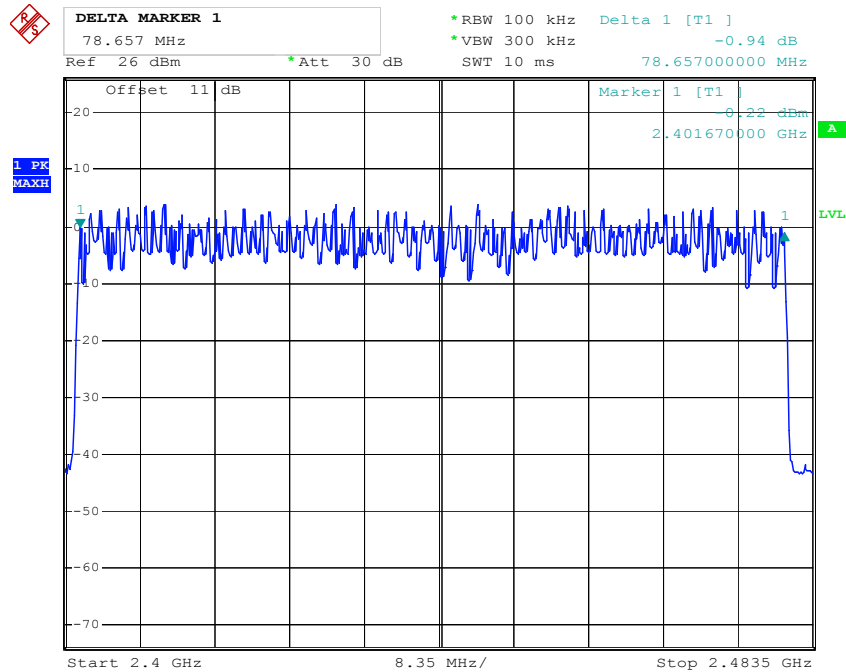

Comment A:
 Date: 6.SEP.2018 16:51:42

8. DWELL TIME TEST

8.1. Block Diagram of Test Setup

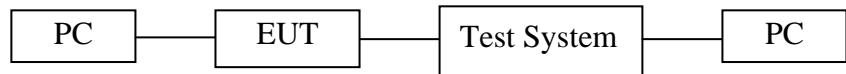

(EUT: e-Screen ETX slot-in Android box)

8.2. The Requirement For Section 15.247(a)(1)(iii)

Section 15.247(a)(1)(iii): Frequency hopping systems in the 2400-2483.5 MHz band shall use at least 15 channels. The average time of occupancy on any channel shall not be greater than 0.4 seconds within a period of 0.4 seconds multiplied by the number of hopping channels employed. Frequency hopping systems may avoid or suppress transmissions on a particular hopping frequency provided that a minimum of 15 channels are used.

8.3. EUT Configuration on Measurement

The equipment are installed on the emission measurement to meet the commission requirements and operating regulations in a manner which tends to maximize its emission characteristics in normal application.

8.4. Operating Condition of EUT

8.4.1. Setup the EUT and simulator as shown as Section 8.1.

8.4.2. Turn on the power of all equipment.

8.4.3. Let the EUT work in TX (Hopping on) modes measure it. The transmit frequency are 2402-2480MHz. We select 2402MHz, 2441MHz, and 2480MHz TX frequency to transmit.

8.5. Test Procedure

8.5.1. The transmitter output was connected to the spectrum analyzer through a low loss cable.

8.5.2. Set center frequency of spectrum analyzer = operating frequency.

8.5.3. Set the spectrum analyzer as RBW=1MHz, VBW=3MHz, Span=0Hz, Adjust Sweep=5ms, 10ms, 15ms. Get the pulse time.

8.5.4.Repeat above procedures until all frequency measured were complete.

8.6.Test Result

GFSK Mode

Mode	Channel Frequency (MHz)	Pulse Time (ms)	Dwell Time (ms)	Limit (ms)
DH1	2441	0.430	137.60	400
A period transmit time = $0.4 \times 79 = 31.6$ Dwell time = pulse time $\times (1600/(2*79)) \times 31.6$				
DH3	2441	1.700	272.00	400
A period transmit time = $0.4 \times 79 = 31.6$ Dwell time = pulse time $\times (1600/(4*79)) \times 31.6$				
DH5	2441	2.940	313.60	400
A period transmit time = $0.4 \times 79 = 31.6$ Dwell time = pulse time $\times (1600/(6*79)) \times 31.6$				

$\Pi/4$ DQPSK

Mode	Channel Frequency (MHz)	Pulse Time (ms)	Dwell Time (ms)	Limit (ms)
2DH1	2441	0.390	140.80	400
A period transmit time = $0.4 \times 79 = 31.6$ Dwell time = pulse time $\times (1600/(2*79)) \times 31.6$				
2DH3	2441	1.700	272.00	400
A period transmit time = $0.4 \times 79 = 31.6$ Dwell time = pulse time $\times (1600/(4*79)) \times 31.6$				
2DH5	2441	2.910	310.40	400
A period transmit time = $0.4 \times 79 = 31.6$ Dwell time = pulse time $\times (1600/(6*79)) \times 31.6$				

8DPSK Mode

Mode	Channel Frequency (MHz)	Pulse Time (ms)	Dwell Time (ms)	Limit (ms)
3DH1	2441	0.390	140.80	400
A period transmit time = $0.4 \times 79 = 31.6$ Dwell time = pulse time $\times (1600/(2*79)) \times 31.6$				
3DH3	2441	1.700	272.00	400
A period transmit time = $0.4 \times 79 = 31.6$ Dwell time = pulse time $\times (1600/(4*79)) \times 31.6$				
3DH5	2441	2.940	313.60	400
A period transmit time = $0.4 \times 79 = 31.6$ Dwell time = pulse time $\times (1600/(6*79)) \times 31.6$				

Note: We tested GFSK mode, $\Pi/4$ -DQPSK Mode and 8DPSK mode and recorded the worst case data for all test mode.

The spectrum analyzer plots are attached as below.

GFSK Mode

DH1 Middle channel

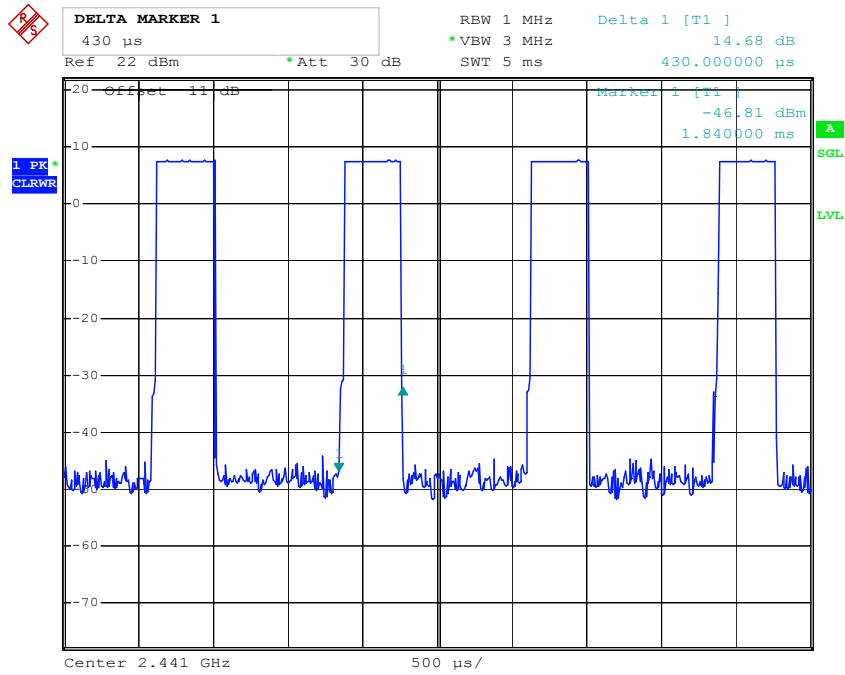

Comment A:
Date: 6.SEP.2018 18:03:00

DH3 Middle channel

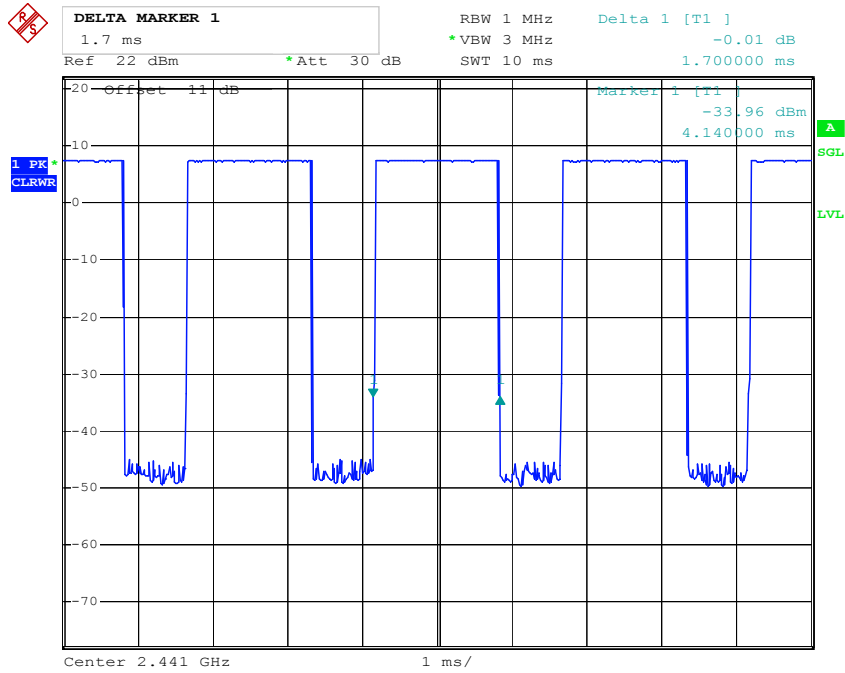

Comment A:
Date: 6.SEP.2018 18:04:28

DH5 Middle channel

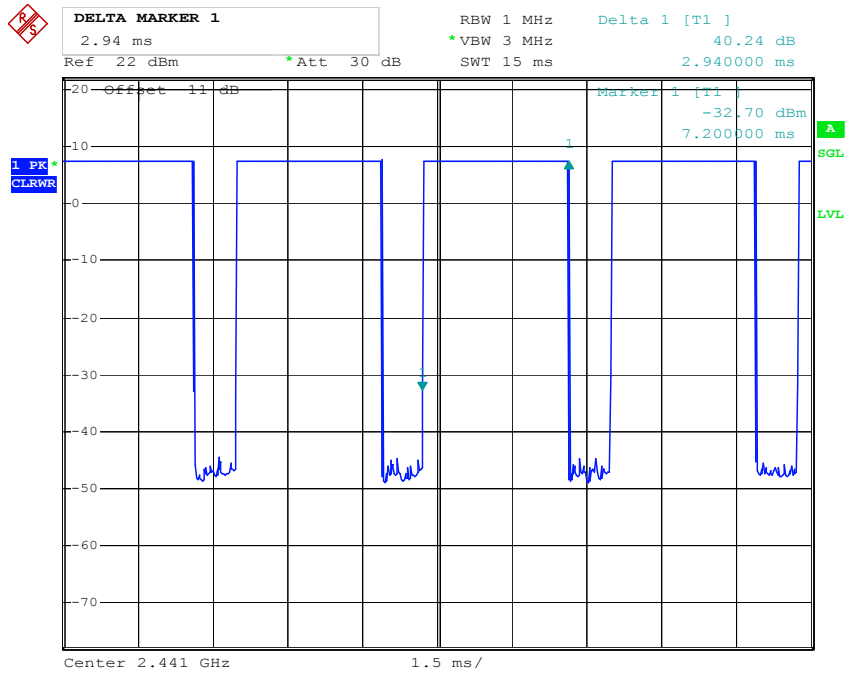

Comment A:
 Date: 6.SEP.2018 18:05:31

$\Pi/4$ DQPSK

2DH1 Middle channel

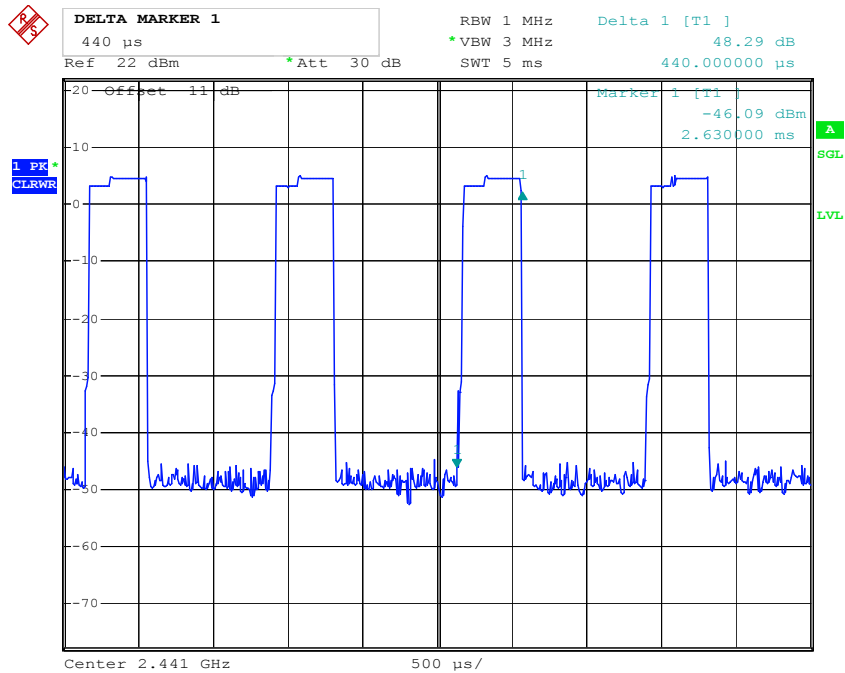

Comment A:
 Date: 6.SEP.2018 18:06:33

2DH3 Middle channel

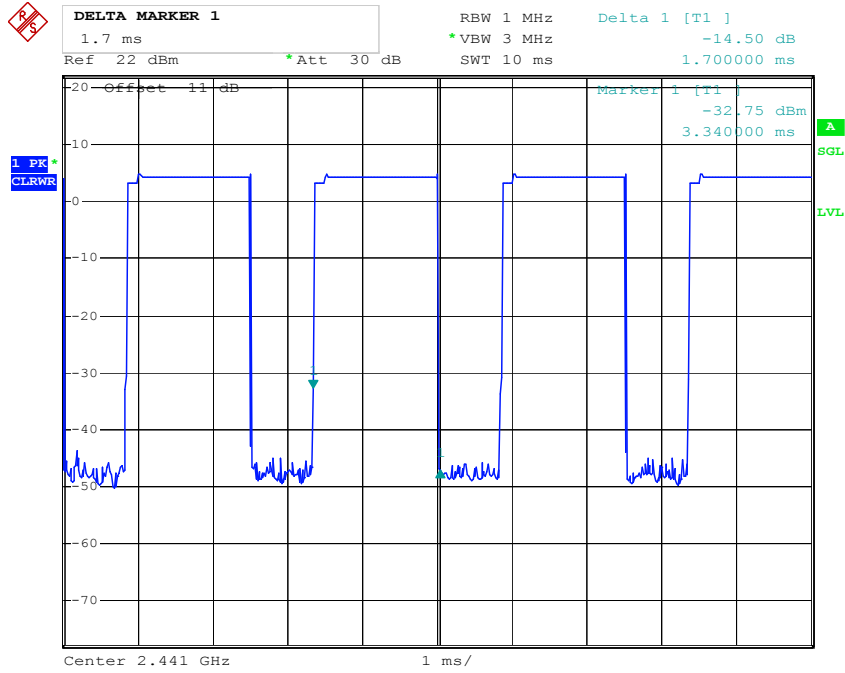

Comment A:
 Date: 6.SEP.2018 18:07:43

2DH5 Middle channel

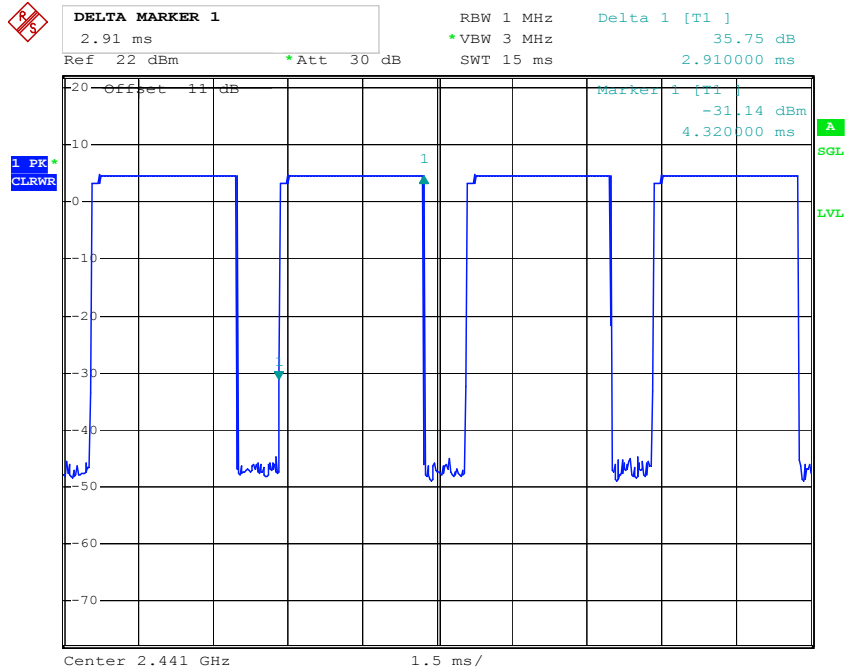

Comment A:
 Date: 6.SEP.2018 18:08:32

8DPSK Mode

3DH1 Middle channel

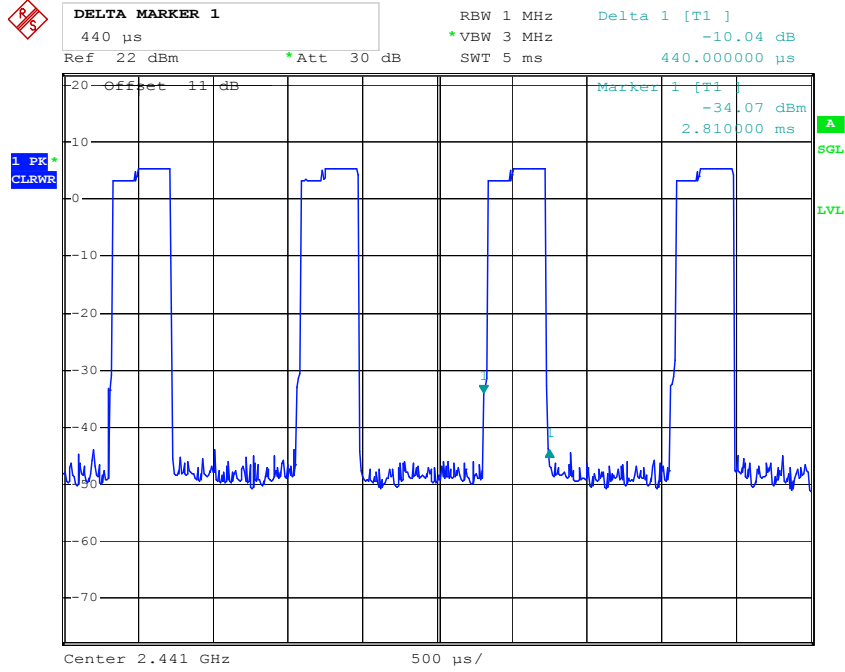

Comment A:
Date: 6.SEP.2018 18:09:33

3DH3 Middle channel

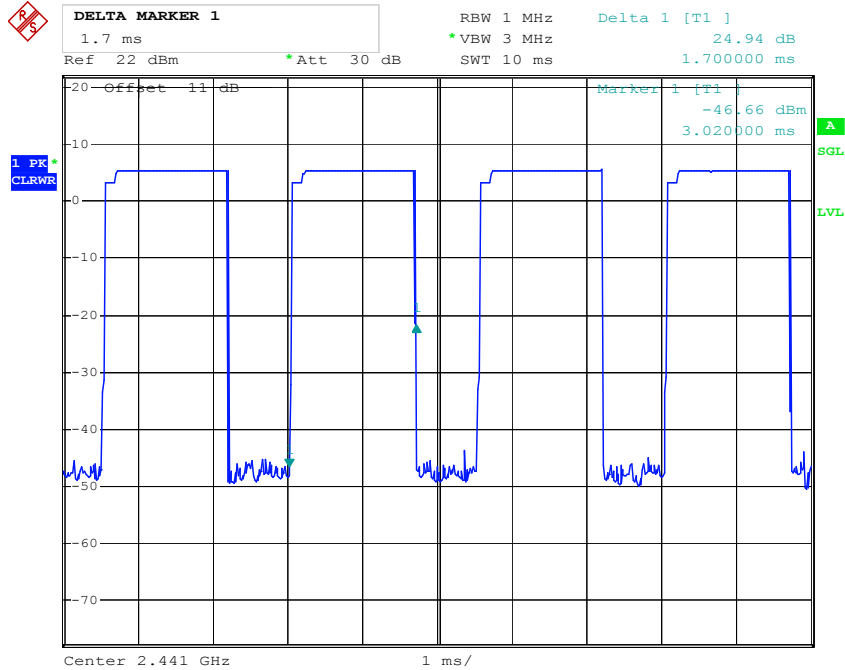

Comment A:
Date: 6.SEP.2018 18:10:26

3DH5 Middle channel

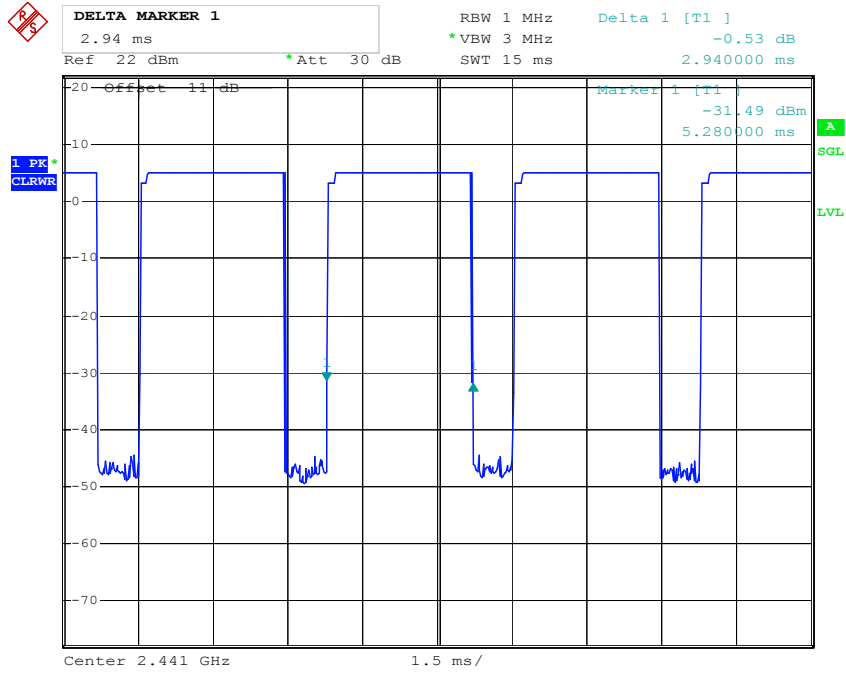

Comment A:
Date: 6.SEP.2018 18:11:32

9. MAXIMUM PEAK OUTPUT POWER TEST

9.1. Block Diagram of Test Setup

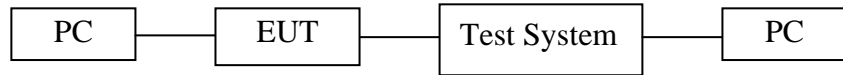

(EUT: e-Screen ETX slot-in Android box)

9.2. The Requirement For Section 15.247(b)(1)

Section 15.247(b)(1): For frequency hopping systems operating in the 2400-2483.5 MHz band employing at least 75 non-overlapping hopping channels, and all frequency hopping systems in the 5725-5850 MHz band: 1 watt. For all other frequency hopping systems in the 2400-2483.5 MHz band: 0.125 watts.

9.3. EUT Configuration on Measurement

The equipment are installed on the emission Measurement to meet the commission requirements and operating regulations in a manner which tends to maximize its emission characteristics in normal application.

9.4. Operating Condition of EUT

9.4.1. Setup the EUT and simulator as shown as Section 9.1.

9.4.2. Turn on the power of all equipment.

9.4.3. Let the EUT work in TX (Hopping off) modes measure it. The transmit frequency are 2402-2480MHz. We select 2402MHz, 2441MHz, and 2480MHz TX frequency to transmit.

9.5. Test Procedure

9.5.1. The transmitter output was connected to the spectrum analyzer through a low loss cable.

9.5.2. Set RBW of spectrum analyzer to 3MHz and VBW to 3MHz for GFSK mode

9.5.3. Set RBW of spectrum analyzer to 3MHz and VBW to 3MHz for other mode

9.5.4. Measurement the maximum peak output power.

9.6. Test Result

GFSK Mode

Channel	Frequency (MHz)	Peak Output Power (dBm/W)	Limits dBm / W
Low	2402	6.25/0.0042	21 / 0.125
Middle	2441	7.46/0.0056	21 / 0.125
High	2480	7.11/0.0051	21 / 0.125

Π/4-DQPSK Mode

Channel	Frequency (MHz)	Peak Output Power (dBm/W)	Limits dBm / W
Low	2402	4.98/0.0031	21 / 0.125
Middle	2441	5.81/0.0038	21 / 0.125
High	2480	5.35/0.0034	21 / 0.125

8DPSK Mode

Channel	Frequency (MHz)	Peak Output Power (dBm/W)	Limits dBm / W
Low	2402	5.22/0.0033	21 / 0.125
Middle	2441	5.92/0.0039	21 / 0.125
High	2480	5.74/0.0037	21 / 0.125

The spectrum analyzer plots are attached as below.

GFSK Mode

Low channel

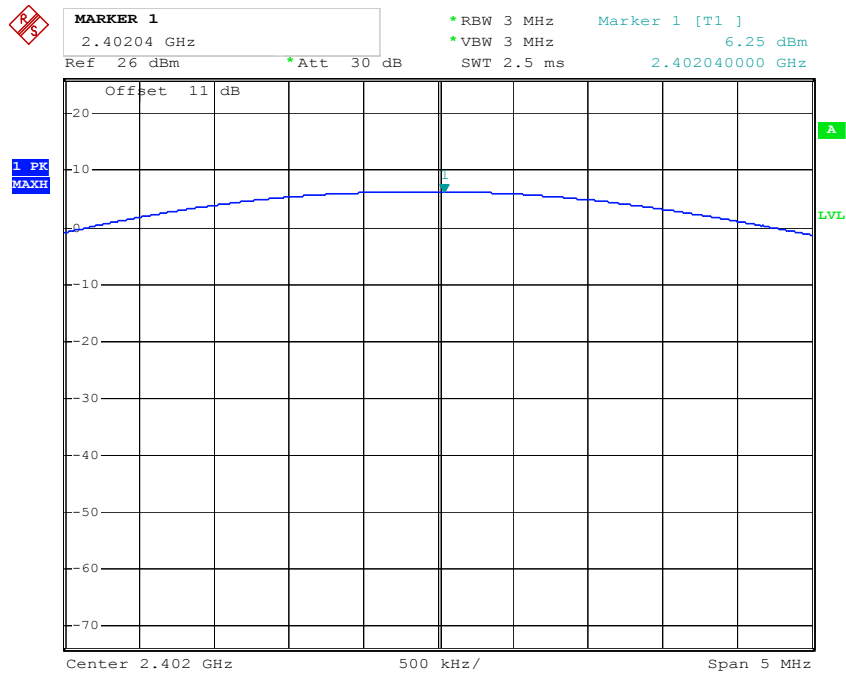

Comment A:
 Date: 6.SEP.2018 16:59:56

Middle channel

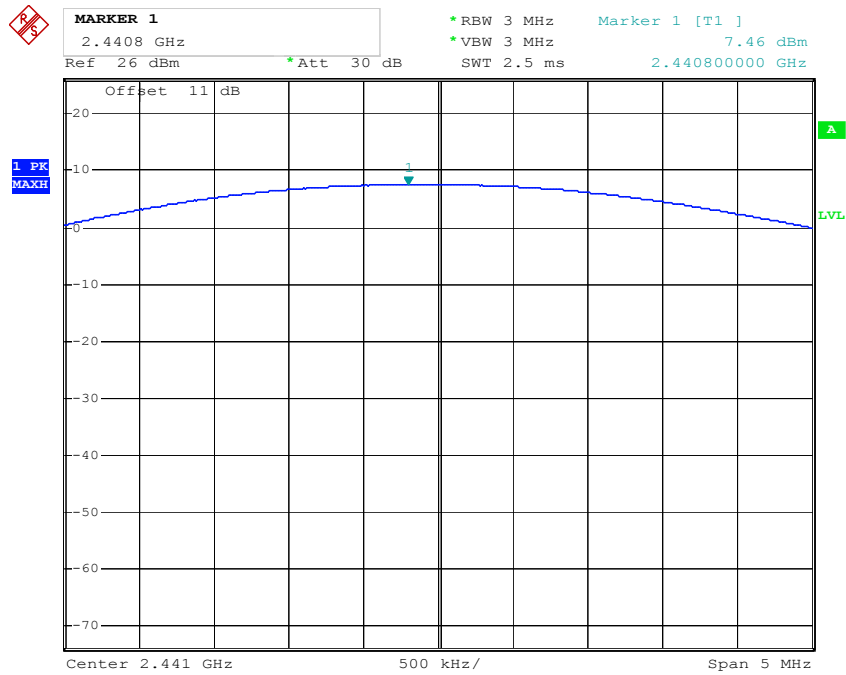

Comment A:
 Date: 6.SEP.2018 17:00:40

High channel

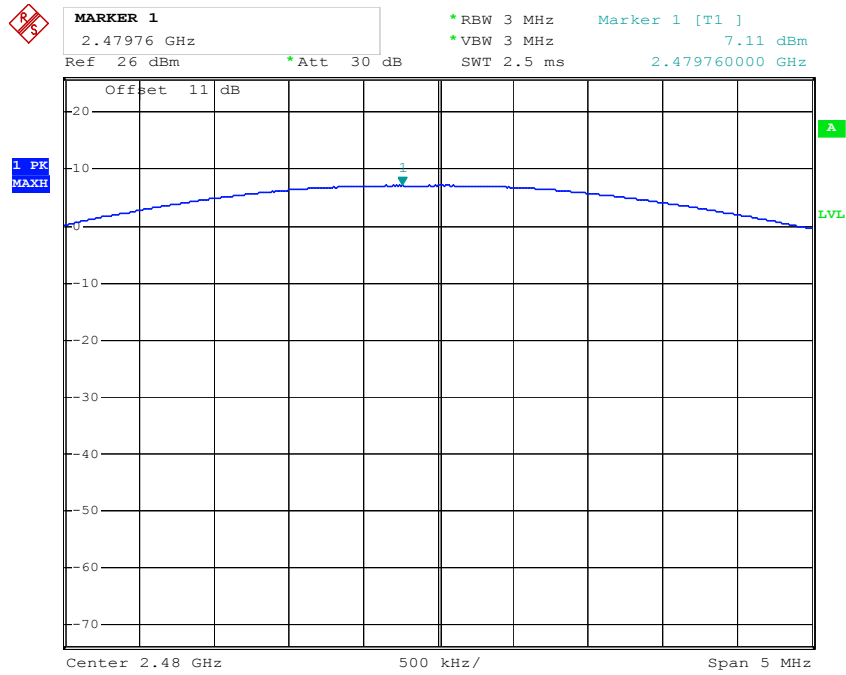

Comment A:
Date: 6.SEP.2018 17:01:15

Π/4-DQPSK Mode

Low channel

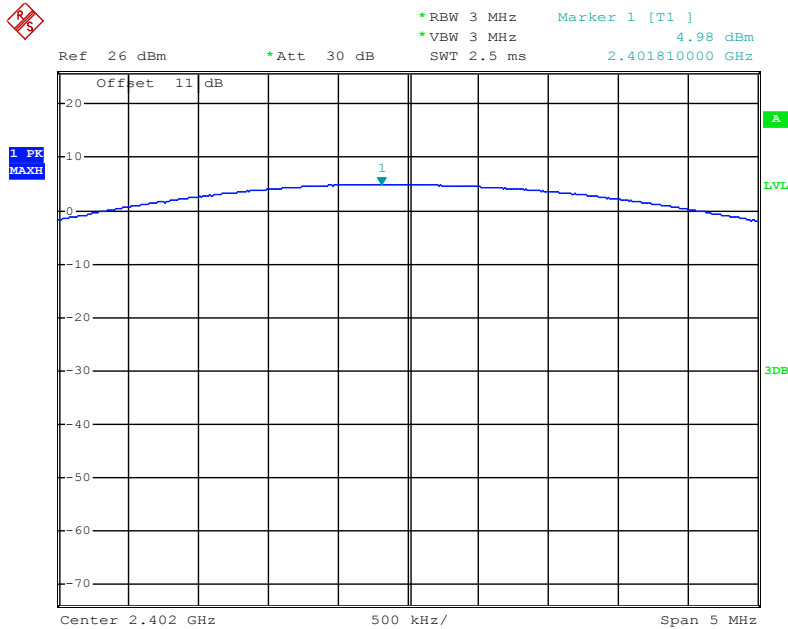

Date: 11.SEP.2018 15:05:01

Middle channel

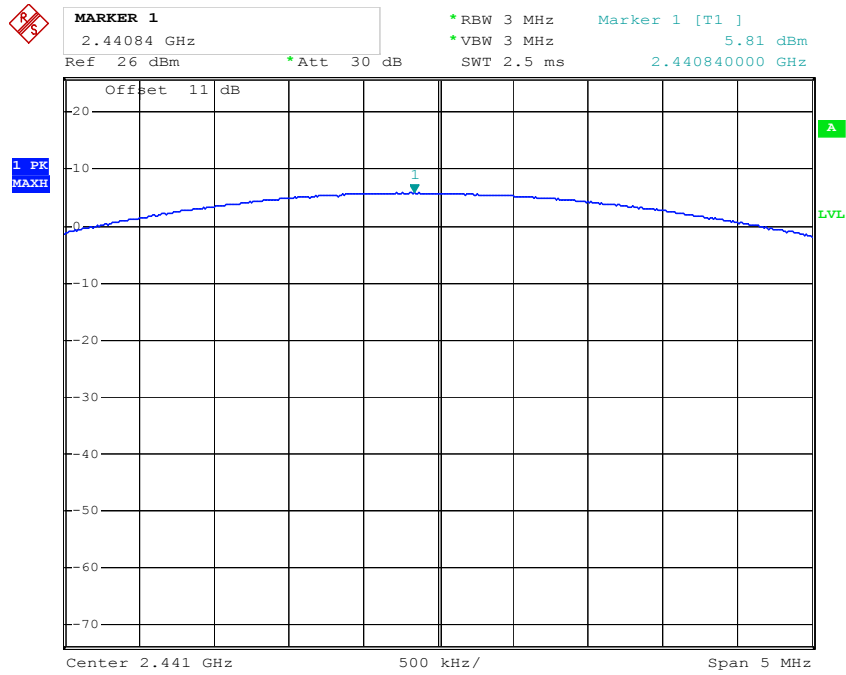

Comment A:
 Date: 6.SEP.2018 17:02:56

High channel

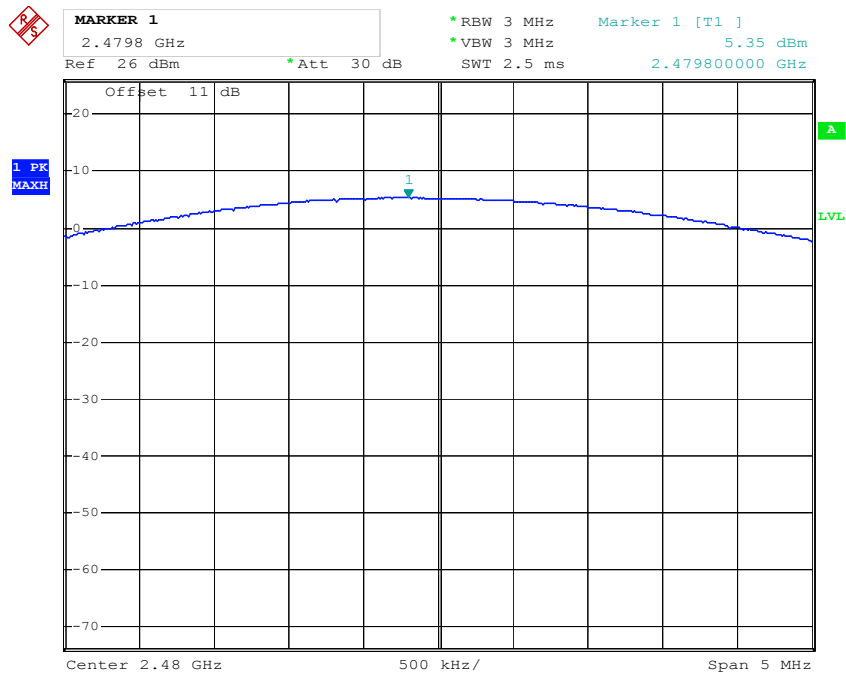

Comment A:
 Date: 6.SEP.2018 17:01:59

8DPSK Mode

Low channel

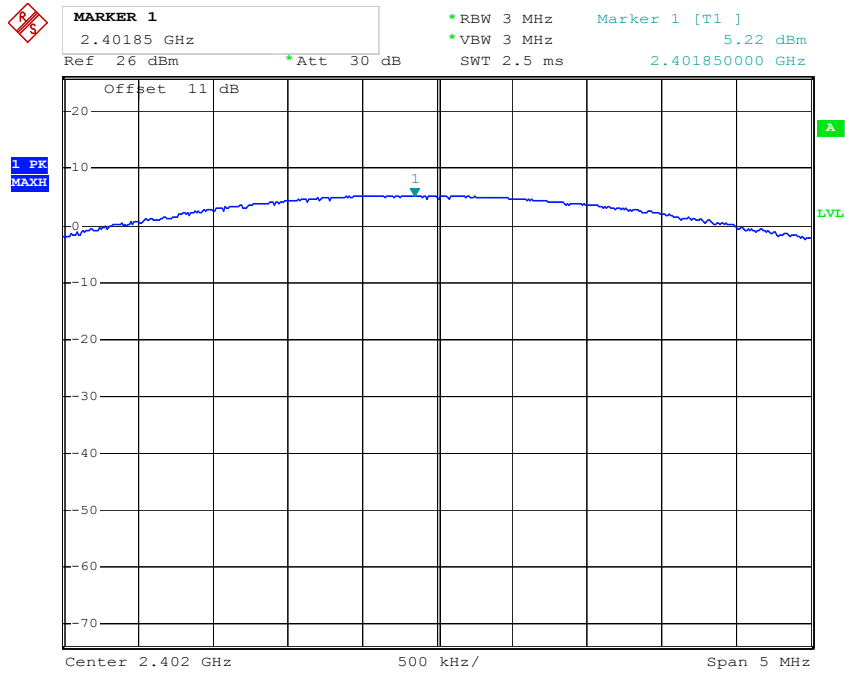

Comment A:
Date: 6.SEP.2018 17:03:26

Middle channel

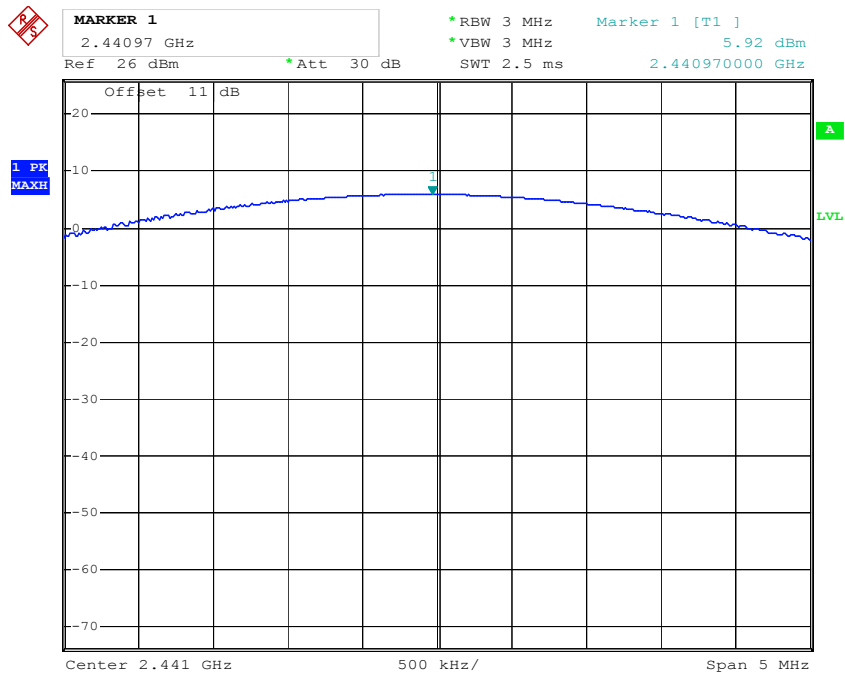

Comment A:
Date: 6.SEP.2018 17:04:39

High channel

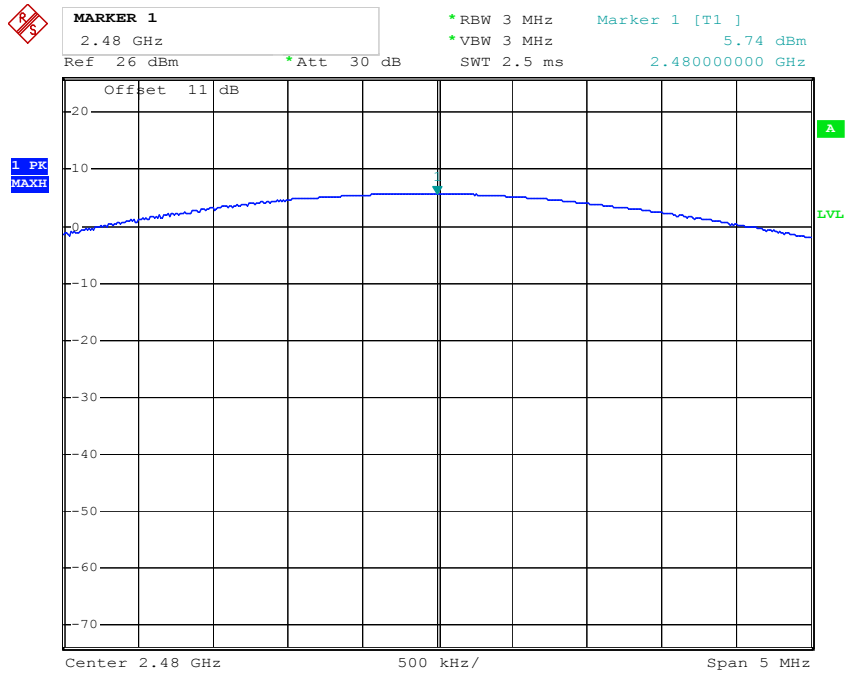

Comment A:
Date: 6.SEP.2018 17:05:22

10. RADIATED EMISSION TEST

10.1. Block Diagram of Test Setup

10.1.1. Block diagram of connection between the EUT and peripherals

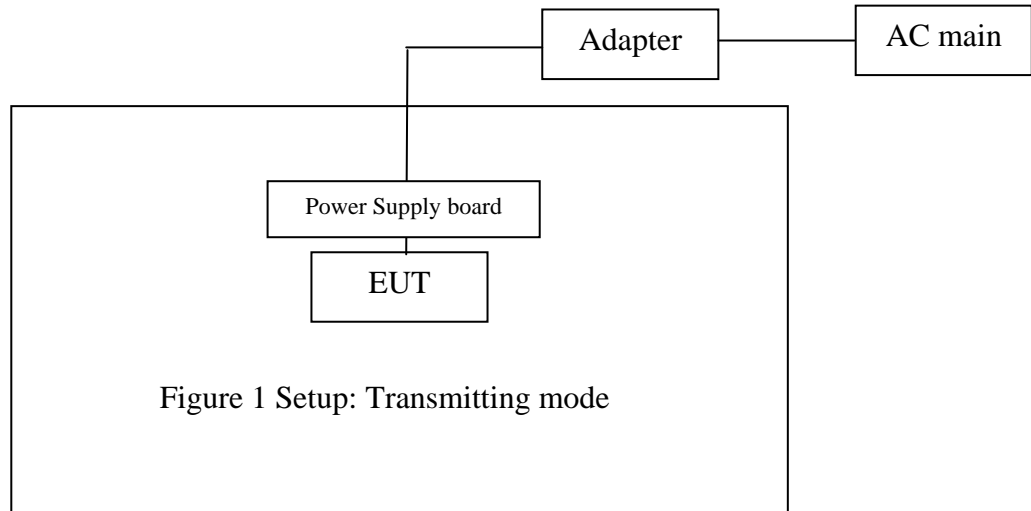

(EUT: e-Screen ETX slot-in Android box)

10.1.2. Semi-Anechoic Chamber Test Setup Diagram

(A) Radiated Emission Test Set-Up, Frequency below 30MHz

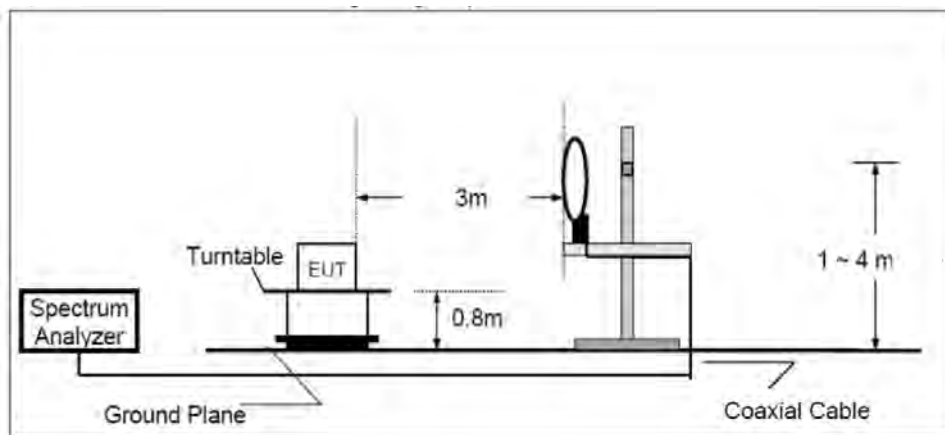

(B) Radiated Emission Test Set-Up, Frequency below 1GHz

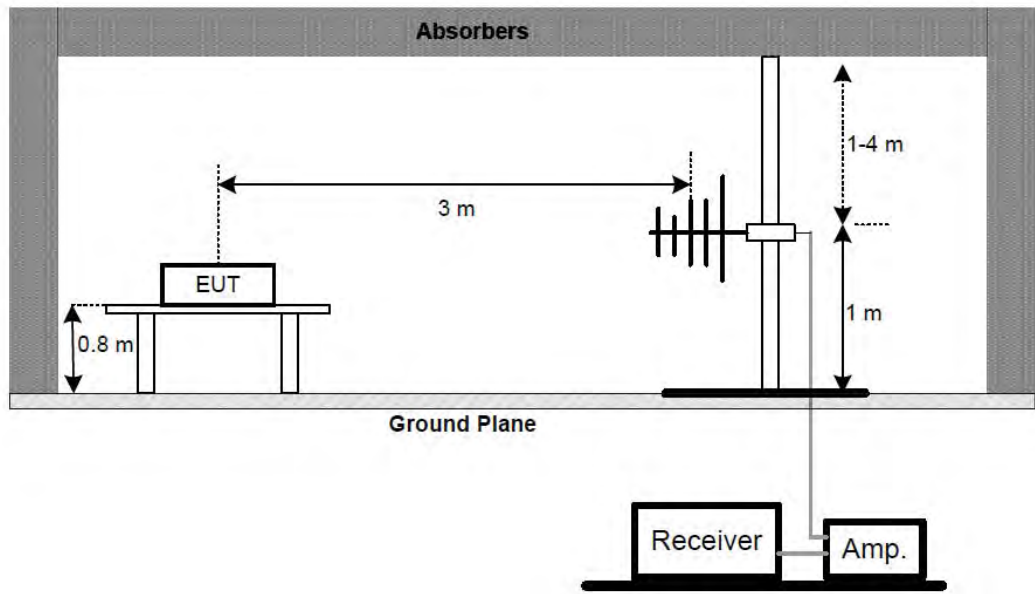

Above 1GHz:

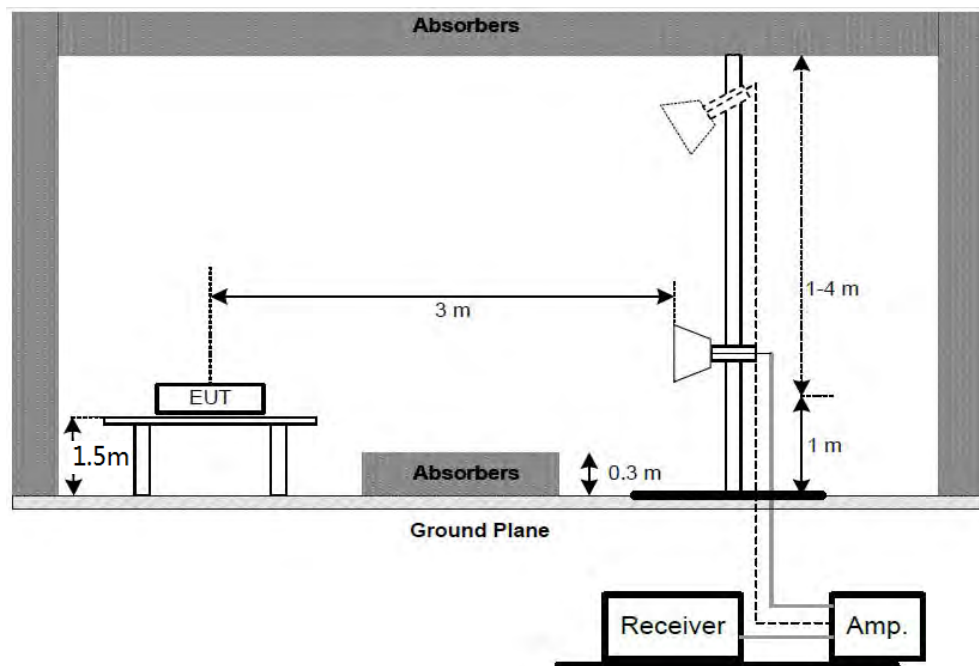

10.2.The Limit For Section 15.247(d)

Section 15.247(d): In any 100 kHz bandwidth outside the frequency band in which the spread spectrum or digitally modulated intentional radiator is operating, the radio frequency power that is produced by the intentional radiator shall be at least 20 dB below that in the 100 kHz bandwidth within the band that contains the highest level of the desired power, based on either an RF conducted or a radiated measurement, provided the transmitter demonstrates compliance with the peak conducted power limits. If the transmitter complies with the conducted power limits based on the use of RMS averaging over a time interval, as permitted under paragraph (b)(3) of this section, the attenuation required under this paragraph shall be 30 dB instead of 20 dB. Attenuation below the general limits specified in Section 15.209(a) is not required. In addition, radiated emissions which fall in the restricted bands, as defined in Section 15.205(a), must also comply with the radiated emission limits specified in Section 15.209(a).

10.3.Restricted bands of operation

10.3.1.FCC Part 15.205 Restricted bands of operation

(a) Except as shown in paragraph (d) of this section, Only spurious emissions are permitted in any of the frequency bands listed below:

MHz	MHz	MHz	GHz
0.090-0.110	16.42-16.423	399.9-410	4.5-5.15
¹ 0.495-0.505	16.69475-16.69525	608-614	5.35-5.46
2.1735-2.1905	16.80425-16.80475	960-1240	7.25-7.75
4.125-4.128	25.5-25.67	1300-1427	8.025-8.5
4.17725-4.17775	37.5-38.25	1435-1626.5	9.0-9.2
4.20725-4.20775	73-74.6	1645.5-1646.5	9.3-9.5
6.215-6.218	74.8-75.2	1660-1710	10.6-12.7
6.26775-6.26825	108-121.94	1718.8-1722.2	13.25-13.4
6.31175-6.31225	123-138	2200-2300	14.47-14.5
8.291-8.294	149.9-150.05	2310-2390	15.35-16.2
8.362-8.366	156.52475-156.52525	2483.5-2500	17.7-21.4
8.37625-8.38675	156.7-156.9	2690-2900	22.01-23.12
8.41425-8.41475	162.0125-167.17	3260-3267	23.6-24.0
12.29-12.293	167.72-173.2	3332-3339	31.2-31.8
12.51975-12.52025	240-285	3345.8-3358	36.43-36.5
12.57675-12.57725	322-335.4	3600-4400	(²)
13.36-13.41			

¹Until February 1, 1999, this restricted band shall be 0.490-0.510

²Above 38.6

(b) Except as provided in paragraphs (d) and (e), the field strength of emission appearing within these frequency bands shall not exceed the limits shown in Section 15.209. At frequencies equal to or less than 1000MHz, Compliance with the limits in Section 15.209 shall be demonstrated using measurement instrumentation employing a CISPR quasi-peak detector. Above 1000MHz, compliance with the emission limits in Section 15.209 shall be demonstrated based on the average value of the measured emissions. The provisions in Section 15.35 apply to these measurements.

10.4. Configuration of EUT on Measurement

The equipment is installed on Radiated Emission Measurement to meet the commission requirements and operating regulations in a manner which tends to maximize its emission characteristics in normal application.

10.5. Test Procedure

The EUT and its simulators are placed on a turntable, which is 0.8 meter high above ground (Below 1GHz). The EUT and its simulators are placed on a turntable, which is 1.5 meter high above ground (Above 1GHz). The turntable can rotate 360 degrees to determine the position of the maximum emission level. EUT is set 3.0 meters away from the receiving antenna, which is mounted on an antenna tower. The antenna can be moved up and down between 1.0 meter and 4 meters to find out the maximum emission level. Broadband antenna (calibrated bi-log antenna) is used as receiving antenna. Both horizontal and vertical polarizations of the antenna are set on measurement. In order to find the maximum emission levels, all of the EUT location must be manipulated according to ANSI C63.10:2013 on radiated emission measurement. The EUT was tested in 3 orthogonal planes.

During the radiated emission test, the spectrum analyzer was set with the following configurations:

1. The resolution bandwidth and video bandwidth of test receiver/spectrum analyzer is 120kHz for Quasi-peak at frequency below 1GHz.
2. The resolution bandwidth of test receiver/spectrum analyzer is 1MHz and video bandwidth is 3MHz for peak measurement with peak detector at frequency above 1GHz.
3. The resolution bandwidth of test receiver/spectrum analyzer is 1MHz and video bandwidth is 10Hz for Average measurement with peak detection at frequency above 1GHz.
4. All modes of operation were investigated and the worst-case emissions are reported.

10.6.Data Sample

Frequency (MHz)	Reading (dB μ v)	Factor (dB/m)	Result (dB μ v/m)	Limit (dB μ v/m)	Margin (dB)	Remark
X.XX	28.66	-15.19	13.47	40.0	-26.53	QP

Frequency(MHz) = Emission frequency in MHz

Reading(dB μ v) = Uncorrected Analyzer/Receiver reading

Factor (dB/m) = Antenna factor + Cable Loss – Amplifier gain

Result(dB μ v/m) = Reading(dB μ v) + Factor(dB/m)

Limit (dB μ v/m) = Limit stated in standard

Margin (dB) = Result(dB μ v/m) - Limit (dB μ v/m)

QP = Quasi-peak Reading

Calculation Formula:

Margin(dB) = Result (dB μ V/m)–Limit(dB μ V/m)

Result(dB μ V/m)= Reading(dB μ V)+ Factor(dB/m)

The “Margin” column of the following data tables indicates the degree of compliance with the applicable limit. For example, a margin of -7dB means the emission is 7dB below the limit.

10.7.The Field Strength of Radiation Emission Measurement Results

Note: 1.We tested GFSK mode, $\Pi/4$ DQPSK Mode & 8DPSK mode and recorded the worst case data (GFSK mode) from 30MHz-1GHz.

2.We tested BDR & EDR mode and recorded the worst case data(GFSK mode & 8DPSK mode) from 1GHz-25GHz.

3. The test frequency is from 9KHz to 25GHz, The radiation emission from 9KHz-30MHz and 18-25GHz are not reported, because the levels are too low against the limit.

Below 1GHz

ACCURATE TECHNOLOGY CO., LTD.

 F1,Bldg,A,Changyuan New Material Port Keyuan Rd,
 Science & Industry Park,Nanshan Shenzhen,P.R.China

Site: 2# Chamber

Tel:+86-0755-26503290

Fax:+86-0755-26503396

Job No.: CLN65 XHUA #8

Standard: FCC Class B 3M Radiated

Test item: Radiation Test

Temp.(C)/Hum.(%) 23 C / 48 %

EUT: e-Screen ETX slot-in Android box

Mode: TX 2402MHz

Model: RK3399

Manufacturer: Legamaster International B.V.

Polarization: Horizontal

Power Source: DC 12V

Date: 18/09/25/

Time: 11/12/22

Engineer Signature: WADE

Distance: 3m

Note: Report NO.:ATE20181648

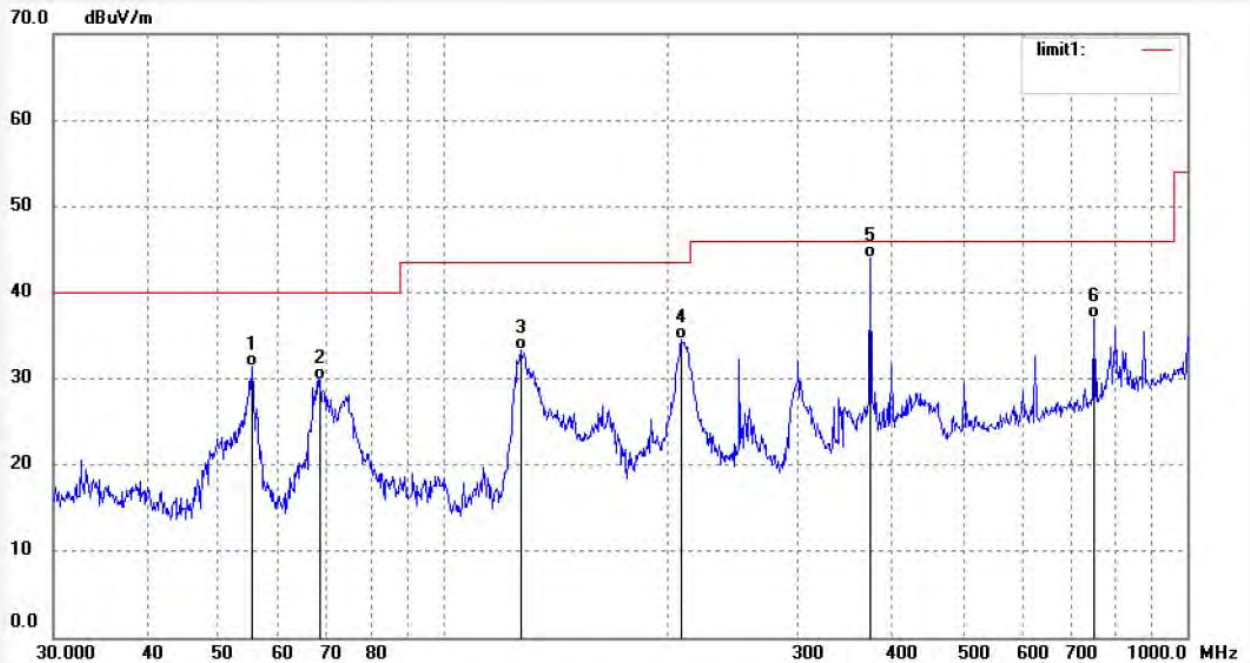

No.	Freq. (MHz)	Reading (dBuV/m)	Factor (dB)	Result (dBuV/m)	Limit (dBuV/m)	Margin (dB)	Detector	Height (cm)	Degree (deg.)	Remark
1	55.4147	44.41	-13.03	31.38	40.00	-8.62	QP	150	281	
2	68.3907	45.76	-15.95	29.81	40.00	-10.19	QP	150	228	
3	127.2176	47.09	-13.69	33.40	43.50	-10.10	QP	150	119	
4	209.3129	46.63	-12.02	34.61	43.50	-8.89	QP	150	238	
5	375.9384	51.08	-7.06	44.02	46.00	-1.98	QP	150	321	
6	750.1082	37.33	-0.29	37.04	46.00	-8.96	QP	150	139	

Job No.: CLN65 XHUA #7
 Standard: FCC Class B 3M Radiated
 Test item: Radiation Test
 Temp.(C)/Hum.(%) 23 C / 48 %
 EUT: e-Screen ETX slot-in Android box
 Mode: TX 2402MHz
 Model: RK3399
 Manufacturer: Legamaster International B.V.

Polarization: Vertical
 Power Source: DC 12V
 Date: 18/09/25/
 Time: 11/10/31
 Engineer Signature: WADE
 Distance: 3m

Note: Report NO.:ATE20181648

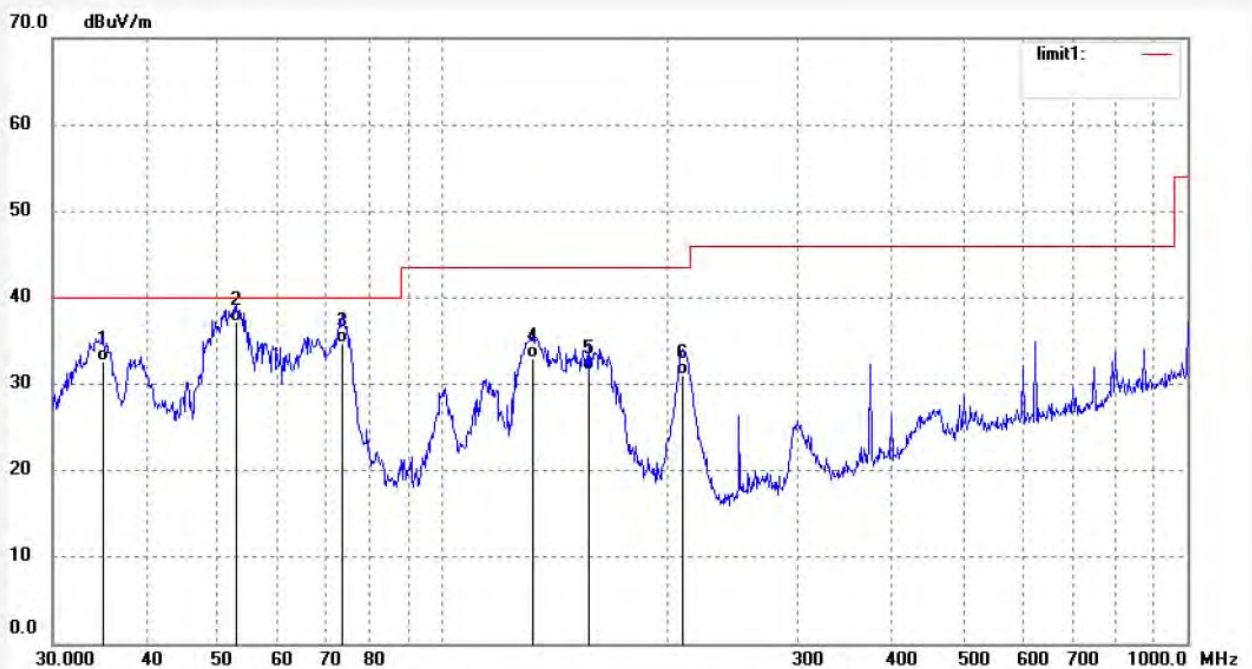

No.	Freq. (MHz)	Reading (dBuV/m)	Factor (dB)	Result (dBuV/m)	Limit (dBuV/m)	Margin (dB)	Detector	Height (cm)	Degree (deg.)	Remark
1	35.0048	43.01	-10.41	32.60	40.00	-7.40	QP	100	128	
2	52.9453	50.00	-12.80	37.20	40.00	-2.80	QP	100	173	
3	73.3593	51.30	-16.51	34.79	40.00	-5.21	QP	100	282	
4	132.2204	46.90	-13.84	33.06	43.50	-10.44	QP	100	121	
5	157.0072	46.27	-14.75	31.52	43.50	-11.98	QP	100	287	
6	210.0482	43.00	-11.99	31.01	43.50	-12.49	QP	100	272	

Job No.: CLN65 XHUA #9

Standard: FCC Class B 3M Radiated

Test item: Radiation Test

Temp.(C)/Hum.(%) 23 C / 48 %

EUT: e-Screen ETX slot-in Android box

Mode: TX 2441MHz

Model: RK3399

Manufacturer: Legamaster International B.V.

Polarization: Horizontal

Power Source: DC 12V

Date: 18/09/25/

Time: 11/13/58

Engineer Signature: WADE

Distance: 3m

Note: Report NO.:ATE20181648

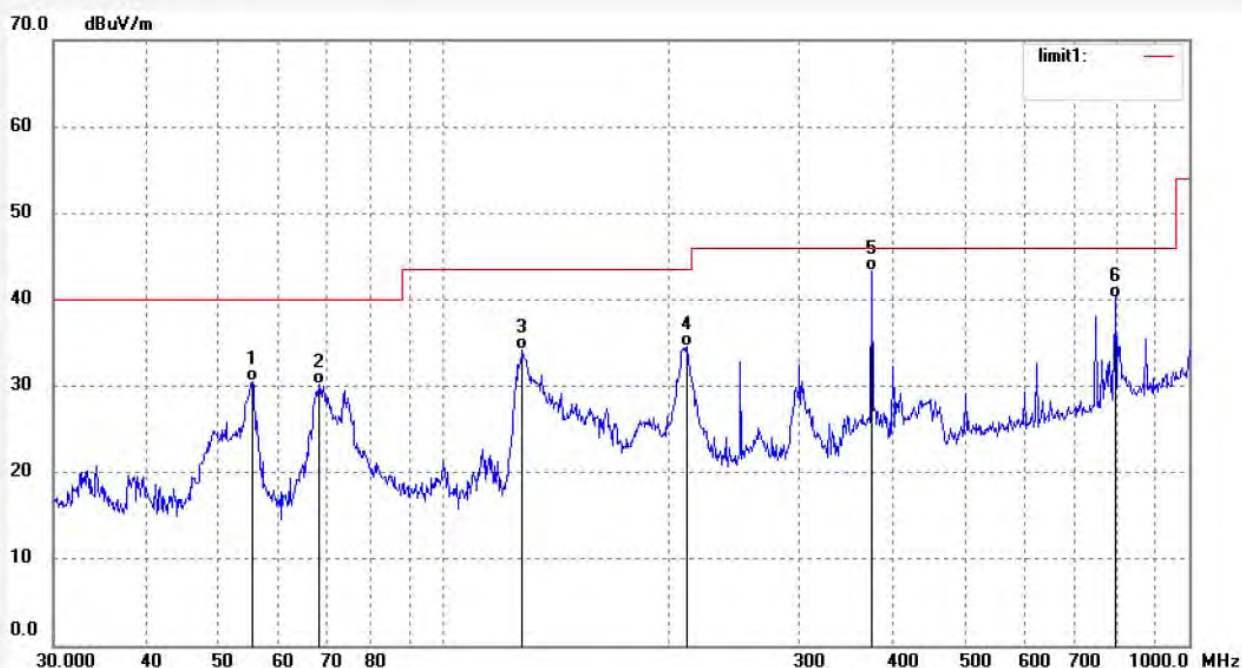

No.	Freq. (MHz)	Reading (dBuV/m)	Factor (dB)	Result (dBuV/m)	Limit (dBuV/m)	Margin (dB)	Detector	Height (cm)	Degree (deg.)	Remark
1	55.4147	43.50	-13.03	30.47	40.00	-9.53	QP	150	231	
2	68.1512	46.19	-15.93	30.26	40.00	-9.74	QP	150	32	
3	127.6645	47.90	-13.70	34.20	43.50	-9.30	QP	150	91	
4	212.2694	46.43	-11.85	34.58	43.50	-8.92	QP	150	137	
5	375.9384	50.36	-7.06	43.30	46.00	-2.70	QP	150	239	
6	796.1829	39.52	0.73	40.25	46.00	-5.75	QP	150	120	

Job No.: CLN65 XHUA #10

Standard: FCC Class B 3M Radiated

Test item: Radiation Test

Temp.(C)/Hum.(%) 23 C / 48 %

EUT: e-Screen ETX slot-in Android box

Mode: TX 2441MHz

Model: RK3399

Manufacturer: Legamaster International B.V.

Polarization: Vertical

Power Source: DC 12V

Date: 18/09/25/

Time: 11/15/08

Engineer Signature: WADE

Distance: 3m

Note: Report NO.:ATE20181648

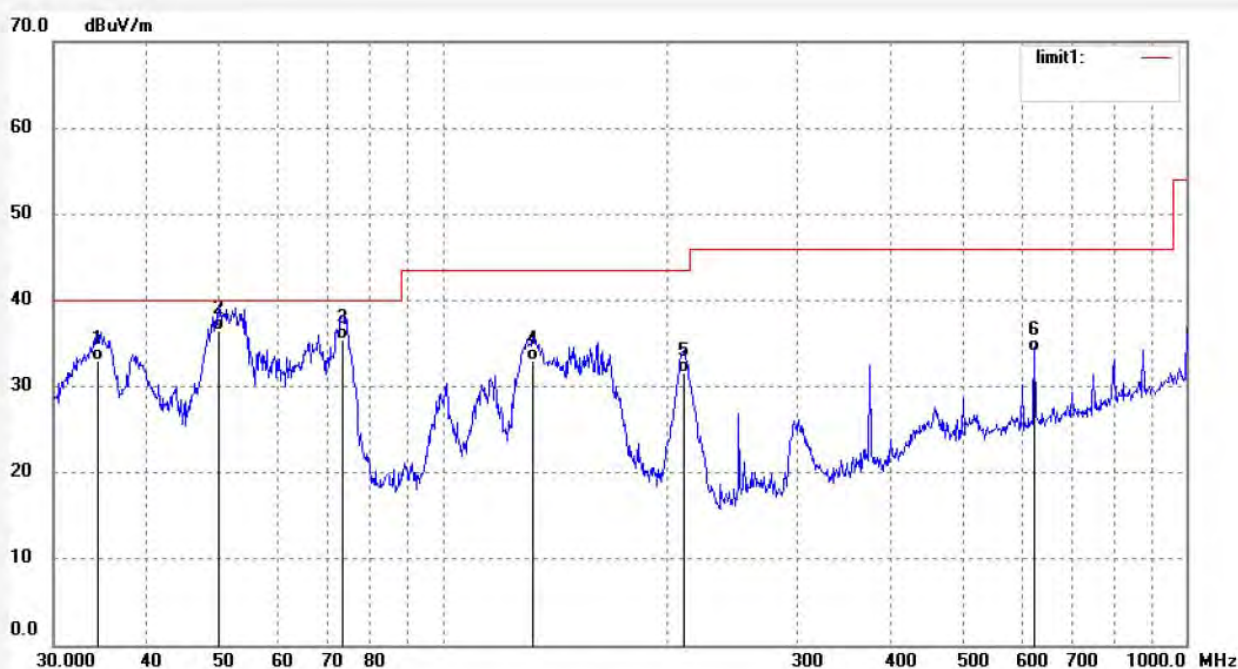

No.	Freq. (MHz)	Reading (dBuV/m)	Factor (dB)	Result (dBuV/m)	Limit (dBuV/m)	Margin (dB)	Detector	Height (cm)	Degree (deg.)	Remark
1	34.3963	43.25	-10.24	33.01	40.00	-6.99	QP	100	329	
2	50.0566	49.10	-12.59	36.51	40.00	-3.49	QP	100	123	
3	73.3593	51.87	-16.51	35.36	40.00	-4.64	QP	100	301	
4	132.2205	46.88	-13.84	33.04	43.50	-10.46	QP	100	307	
5	210.7860	43.57	-11.94	31.63	43.50	-11.87	QP	100	311	
6	625.0779	36.00	-2.00	34.00	46.00	-12.00	QP	100	310	

Job No.: CLN65 XHUA #12

Standard: FCC Class B 3M Radiated

Test item: Radiation Test

Temp.(C)/Hum.(%) 23 C / 48 %

EUT: e-Screen ETX slot-in Android box

Mode: TX 2480MHz

Model: RK3399

Manufacturer: Legamaster International B.V.

Polarization: Horizontal

Power Source: DC 12V

Date: 18/09/25/

Time: 11/17/30

Engineer Signature: WADE

Distance: 3m

Note: Report NO.:ATE20181648

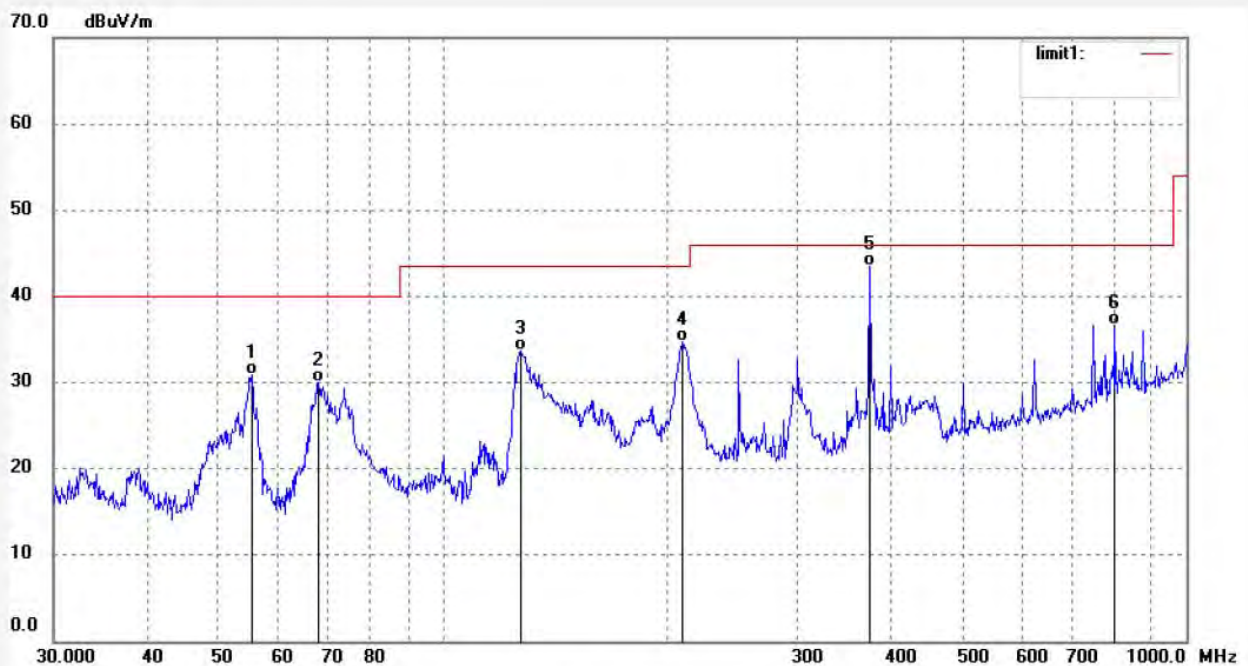

No.	Freq. (MHz)	Reading (dBuV/m)	Factor (dB)	Result (dBuV/m)	Limit (dBuV/m)	Margin (dB)	Detector	Height (cm)	Degree (deg.)	Remark
1	55.4147	43.92	-13.03	30.89	40.00	-9.11	QP	150	319	
2	68.1512	45.88	-15.93	29.95	40.00	-10.05	QP	150	318	
3	127.2176	47.41	-13.69	33.72	43.50	-9.78	QP	150	312	
4	210.0482	46.75	-11.99	34.76	43.50	-8.74	QP	150	126	
5	375.9384	50.55	-7.06	43.49	46.00	-2.51	QP	150	328	
6	801.7862	35.83	0.87	36.70	46.00	-9.30	QP	150	327	



ACCURATE TECHNOLOGY CO., LTD.

F1,Bldg,A,Changyuan New Material Port Keyuan Rd,
Science & Industry Park,Nanshan Shenzhen,P.R.China

Site: 2# Chamber

Tel:+86-0755-26503290

Fax:+86-0755-26503396

Job No.: CLN65 XHUA #11	Polarization: Vertical
Standard: FCC Class B 3M Radiated	Power Source: DC 12V
Test item: Radiation Test	Date: 18/09/25/
Temp.(C)/Hum.(%) 23 C / 48 %	Time: 11/16/05
EUT: e-Screen ETX slot-in Android box	Engineer Signature: WADE
Mode: TX 2480MHz	Distance: 3m
Model: RK3399	
Manufacturer: Legamaster International B.V.	

Note: Report NO.:ATE20181648

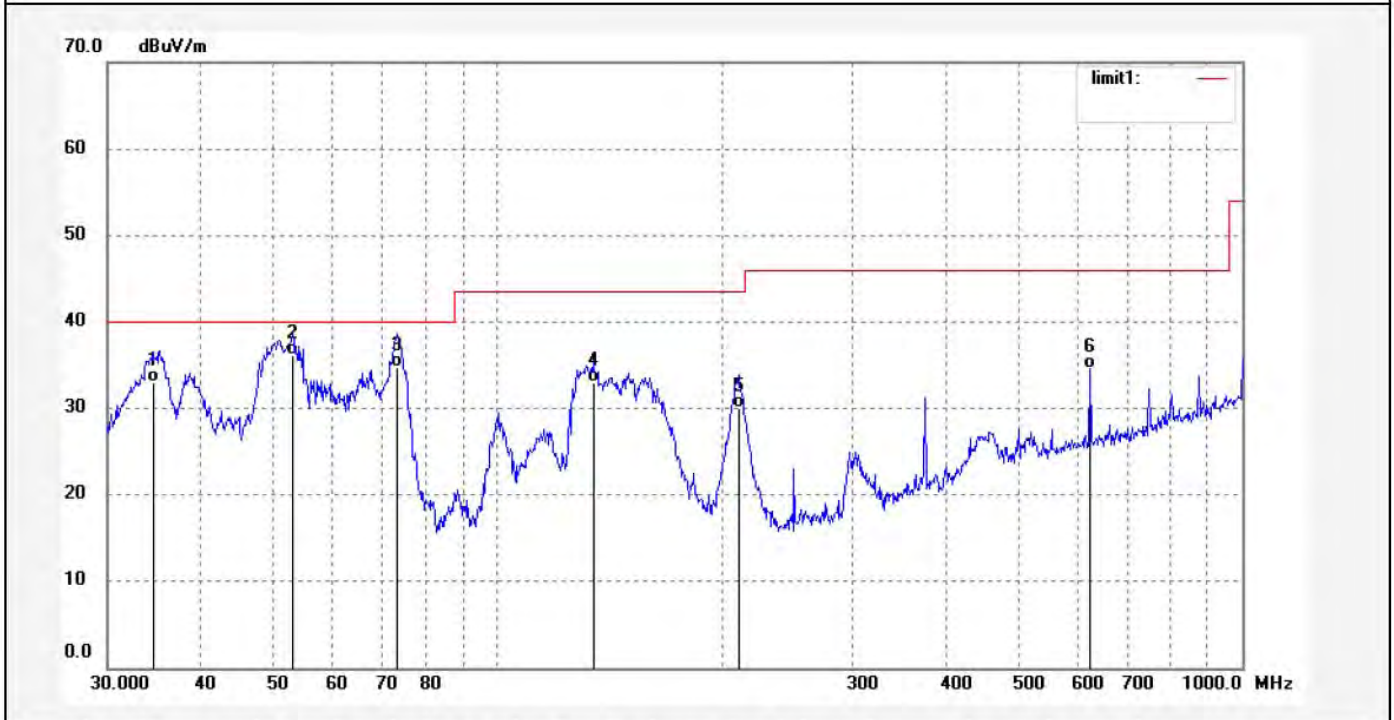

No.	Freq. (MHz)	Reading (dBuV/m)	Factor (dB)	Result (dBuV/m)	Limit (dBuV/m)	Margin (dB)	Detector	Height (cm)	Degree (deg.)	Remark
1	34.5172	43.21	-10.28	32.93	40.00	-7.07	QP	100	319	
2	53.1313	49.00	-12.81	36.19	40.00	-3.81	QP	100	301	
3	73.3593	51.30	-16.51	34.79	40.00	-5.21	QP	100	320	
4	134.5592	46.87	-13.95	32.92	43.50	-10.58	QP	100	138	
5	210.7860	42.00	-11.94	30.06	43.50	-13.44	QP	100	329	
6	625.0779	36.59	-2.00	34.59	46.00	-11.41	QP	100	146	

Above 1GHz



ACCURATE TECHNOLOGY CO., LTD.

F1,Bldg,A,Changyuan New Material Port Keyuan Rd,
Science & Industry Park,Nanshan Shenzhen,P.R.China

Site: 2# Chamber

Tel:+86-0755-26503290

Fax:+86-0755-26503396

Job No.: CLN65 XHUA #42	Polarization: Horizontal
Standard: FCC PK	Power Source: DC 12V
Test item: Radiation Test	Date: 18/09/25/
Temp.(C)/Hum.(%) 23 C / 48 %	Time: 13/48/09
EUT: e-Screen ETX slot-in Android box	Engineer Signature: WADE
Mode: TX 2402MHz (GFSK)	Distance: 3m
Model: RK3399	
Manufacturer: Legamaster International B.V.	

Note: Report No.: ATE20181648

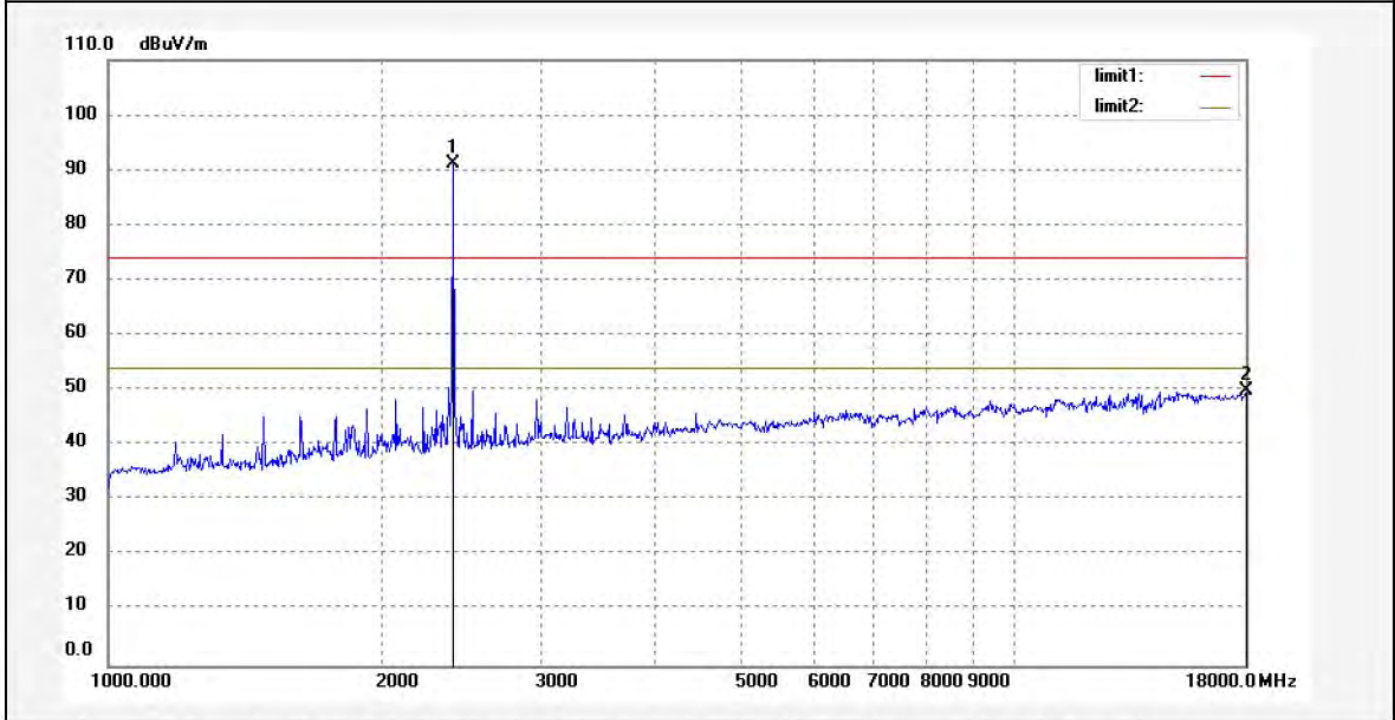

No.	Freq. (MHz)	Reading (dBuV/m)	Factor (dB)	Result (dBuV/m)	Limit (dBuV/m)	Margin (dB)	Detector	Height (cm)	Degree (deg.)	Remark
1	2402.153	51.99	39.28	91.27			peak	150	281	
2	18000.000	-16.27	66.10	49.83	74.00	-24.17	peak	200	127	



ACCURATE TECHNOLOGY CO., LTD.

F1,Bldg,A,Changyuan New Material Port Keyuan Rd,
Science & Industry Park,Nanshan Shenzhen,P.R.China

Site: 2# Chamber

Tel:+86-0755-26503290

Fax:+86-0755-26503396

Job No.: CLN65 XHUA #43	Polarization: Vertical
Standard: FCC PK	Power Source: DC 12V
Test item: Radiation Test	Date: 18/09/25/
Temp.(C)/Hum.(%) 23 C / 48 %	Time: 13/49/09
EUT: e-Screen ETX slot-in Android box	Engineer Signature: WADE
Mode: TX 2402MHz (GFSK)	Distance: 3m
Model: RK3399	
Manufacturer: Legamaster International B.V.	

Note: Report No.: ATE20181648

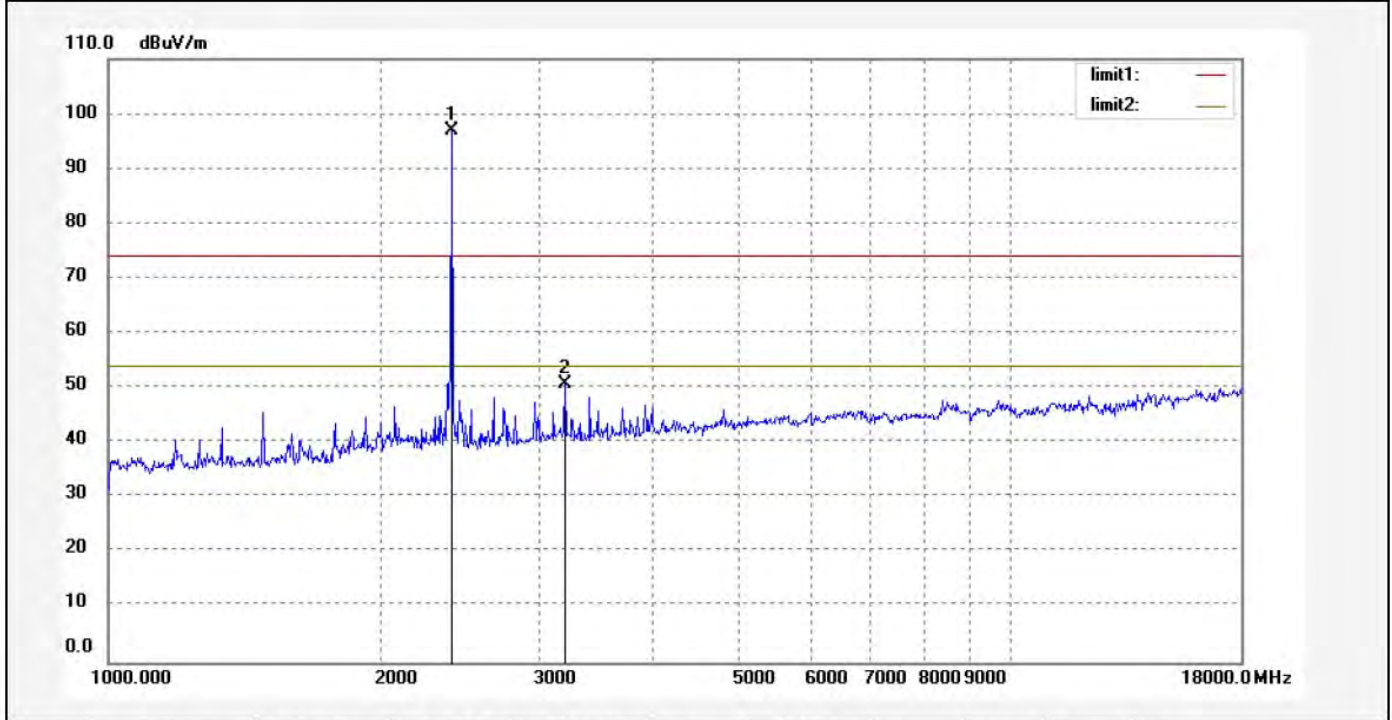

No.	Freq. (MHz)	Reading (dBuV/m)	Factor (dB)	Result (dBuV/m)	Limit (dBuV/m)	Margin (dB)	Detector	Height (cm)	Degree (deg.)	Remark
1	2402.153	57.78	39.28	97.06			peak	150	118	
2	3205.345	10.59	40.27	50.86	74.00	-23.14	peak	160	210	

Job No.: CLN65 XHUA #45	Polarization: Horizontal
Standard: FCC PK	Power Source: DC 12V
Test item: Radiation Test	Date: 18/09/25/
Temp.(C)/Hum.(%) 23 C / 48 %	Time: 13/52/32
EUT: e-Screen ETX slot-in Android box	Engineer Signature: WADE
Mode: TX 2441MHz (GFSK)	Distance: 3m
Model: RK3399	
Manufacturer: Legamaster International B.V.	

Note: Report No.: ATE20181648

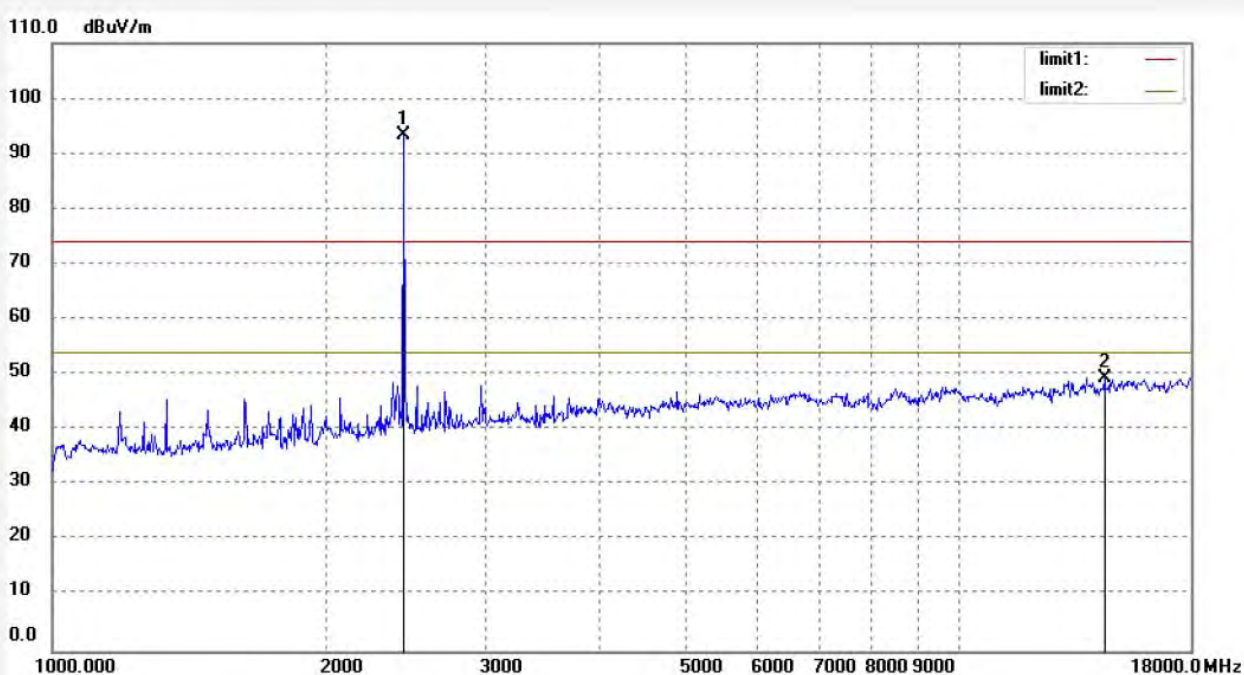

No.	Freq. (MHz)	Reading (dBuV/m)	Factor (dB)	Result (dBuV/m)	Limit (dBuV/m)	Margin (dB)	Detector	Height (cm)	Degree (deg.)	Remark
1	2441.051	53.93	39.46	93.39			peak	150	118	
2	14450.131	-10.89	60.27	49.38	74.00	-24.62	peak	200	132	

Job No.: CLN65 XHUA #44

Standard: FCC PK

Test item: Radiation Test

Temp.(C)/Hum.(%) 23 C / 48 %

EUT: e-Screen ETX slot-in Android box

Mode: TX 2441MHz (GFSK)

Model: RK3399

Manufacturer: Legamaster International B.V.

Polarization: Vertical

Power Source: DC 12V

Date: 18/09/25/

Time: 13/51/28

Engineer Signature: WADE

Distance: 3m

Note: Report No.: ATE20181648

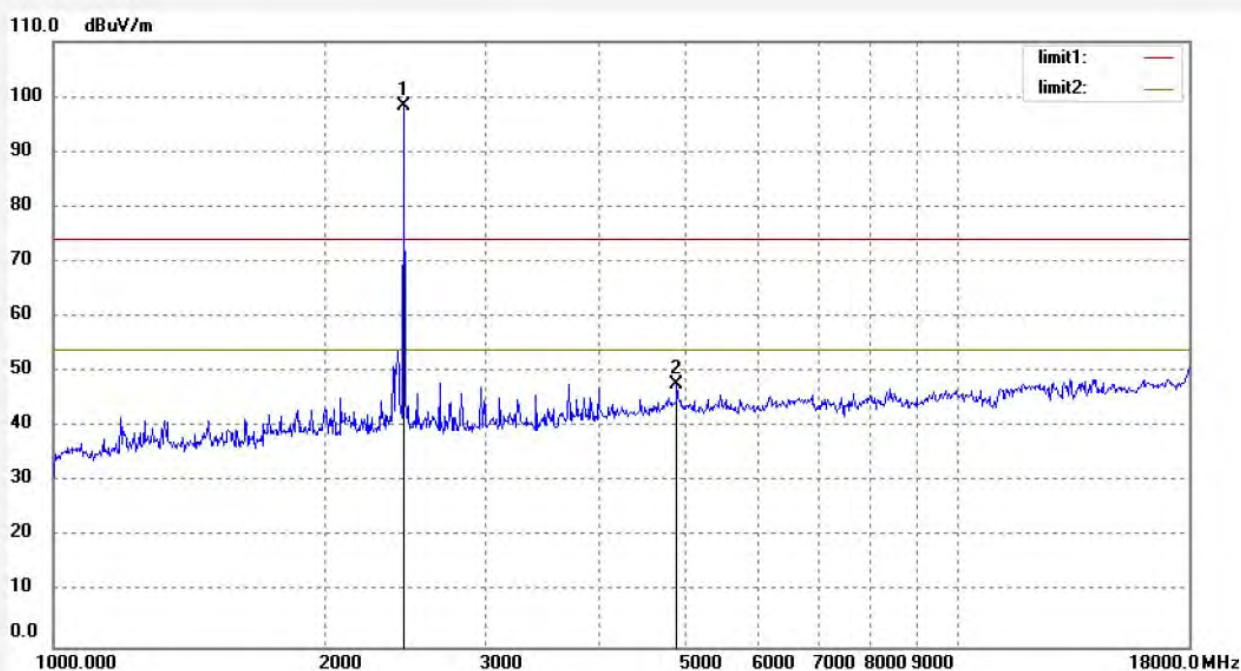

No.	Freq. (MHz)	Reading (dBuV/m)	Factor (dB)	Result (dBuV/m)	Limit (dBuV/m)	Margin (dB)	Detector	Height (cm)	Degree (deg.)	Remark
1	2441.051	58.80	39.46	98.26			peak	150	112	
2	4882.151	3.08	44.73	47.81	74.00	-26.19	peak	150	128	

Job No.: CLN65 XHUA #46

Standard: FCC PK

Test item: Radiation Test

Temp.(C)/Hum.(%) 23 C / 48 %

EUT: e-Screen ETX slot-in Android box

Mode: TX 2480MHz (GFSK)

Model: RK3399

Manufacturer: Legamaster International B.V.

Polarization: Horizontal

Power Source: DC 12V

Date: 18/09/25/

Time: 13/54/05

Engineer Signature: WADE

Distance: 3m

Note: Report No.: ATE20181648

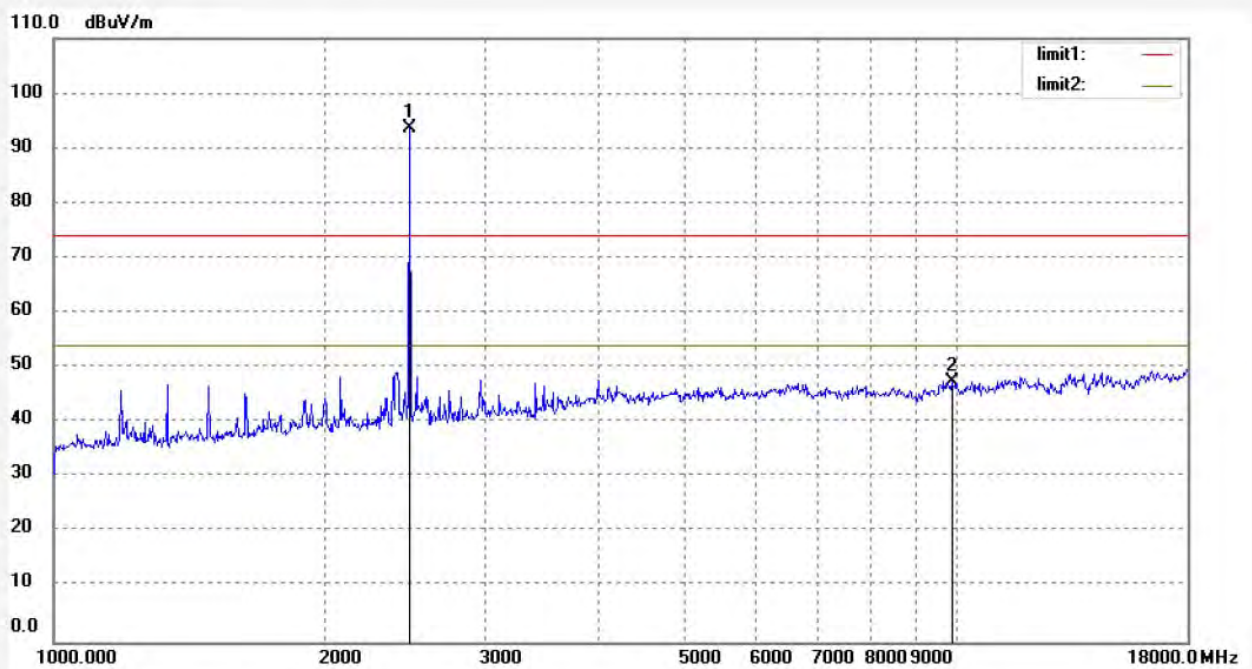

No.	Freq. (MHz)	Reading (dBuV/m)	Factor (dB)	Result (dBuV/m)	Limit (dBuV/m)	Margin (dB)	Detector	Height (cm)	Degree (deg.)	Remark
1	2480.310	54.00	39.61	93.61			peak	150	329	
2	9866.789	-3.57	51.11	47.54	74.00	-26.46	peak	200	137	

ACCURATE TECHNOLOGY CO., LTD.

 F1,Bldg,A,Changyuan New Material Port Keyuan Rd,
 Science & Industry Park,Nanshan Shenzhen,P.R.China

Site: 2# Chamber

Tel:+86-0755-26503290

Fax:+86-0755-26503396

Job No.: CLN65 XHUA #47

Standard: FCC PK

Test item: Radiation Test

Temp.(C)/Hum.(%) 23 C / 48 %

EUT: e-Screen ETX slot-in Android box

Mode: TX 2480MHz (GFSK)

Model: RK3399

Manufacturer: Legamaster International B.V.

Polarization: Vertical

Power Source: DC 12V

Date: 18/09/25/

Time: 13/55/06

Engineer Signature: WADE

Distance: 3m

Note: Report No.: ATE20181648

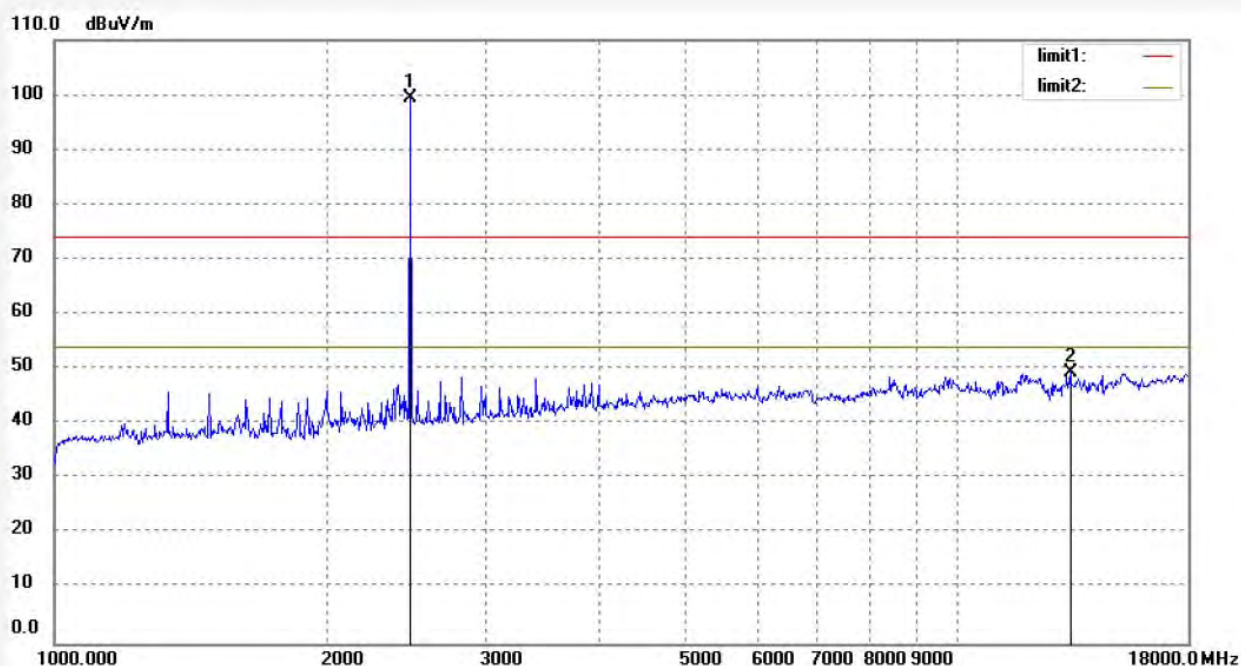

No.	Freq. (MHz)	Reading (dBuV/m)	Factor (dB)	Result (dBuV/m)	Limit (dBuV/m)	Margin (dB)	Detector	Height (cm)	Degree (deg.)	Remark
1	2480.310	59.67	39.61	99.28			peak	150	181	
2	13326.747	-7.36	56.65	49.29	74.00	-24.71	peak	200	302	



ACCURATE TECHNOLOGY CO., LTD.

F1,Bldg,A,Changyuan New Material Port Keyuan Rd,
Science & Industry Park,Nanshan Shenzhen,P.R.China

Site: 2# Chamber

Tel:+86-0755-26503290

Fax:+86-0755-26503396

Job No.: CLN65 XHUA #53	Polarization: Horizontal
Standard: FCC PK	Power Source: DC 12V
Test item: Radiation Test	Date: 18/09/25/
Temp.(C)/Hum.(%) 23 C / 48 %	Time: 14/03/04
EUT: e-Screen ETX slot-in Android box	Engineer Signature: WADE
Mode: TX 2402MHz (8DPSK)	Distance: 3m
Model: RK3399	
Manufacturer: Legamaster International B.V.	

Note: Report No.: ATE20181648

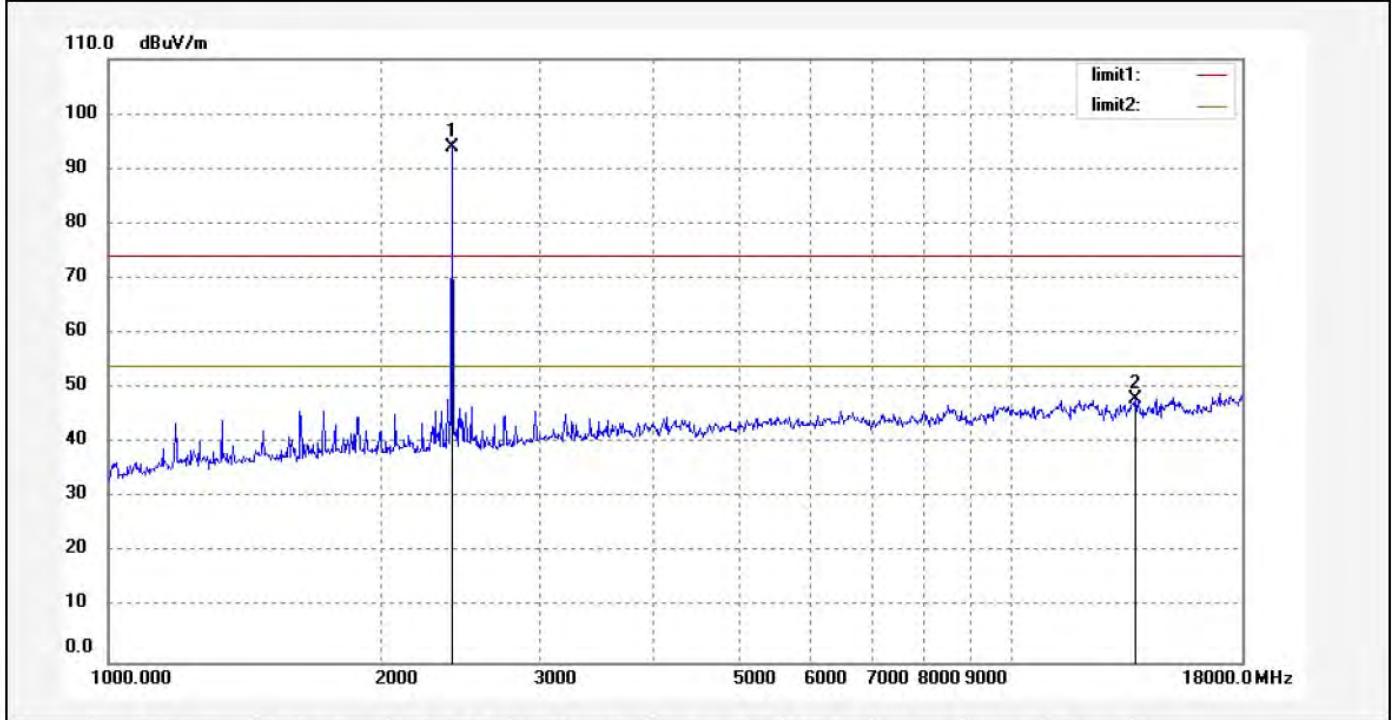

No.	Freq. (MHz)	Reading (dBuV/m)	Factor (dB)	Result (dBuV/m)	Limit (dBuV/m)	Margin (dB)	Detector	Height (cm)	Degree (deg.)	Remark
1	2402.153	54.65	39.28	93.93			peak	150	173	
2	13717.561	-9.59	57.52	47.93	74.00	-26.07	peak	200	229	



ACCURATE TECHNOLOGY CO., LTD.

F1,Bldg,A,Changyuan New Material Port Keyuan Rd,
Science & Industry Park,Nanshan Shenzhen,P.R.China

Site: 2# Chamber

Tel:+86-0755-26503290

Fax:+86-0755-26503396

Job No.: CLN65 XHUA #52	Polarization: Vertical
Standard: FCC PK	Power Source: DC 12V
Test item: Radiation Test	Date: 18/09/25/
Temp.(C)/Hum.(%) 23 C / 48 %	Time: 14/01/42
EUT: e-Screen ETX slot-in Android box	Engineer Signature: WADE
Mode: TX 2402MHz (8DPSK)	Distance: 3m
Model: RK3399	
Manufacturer: Legamaster International B.V.	

Note: Report No.: ATE20181648

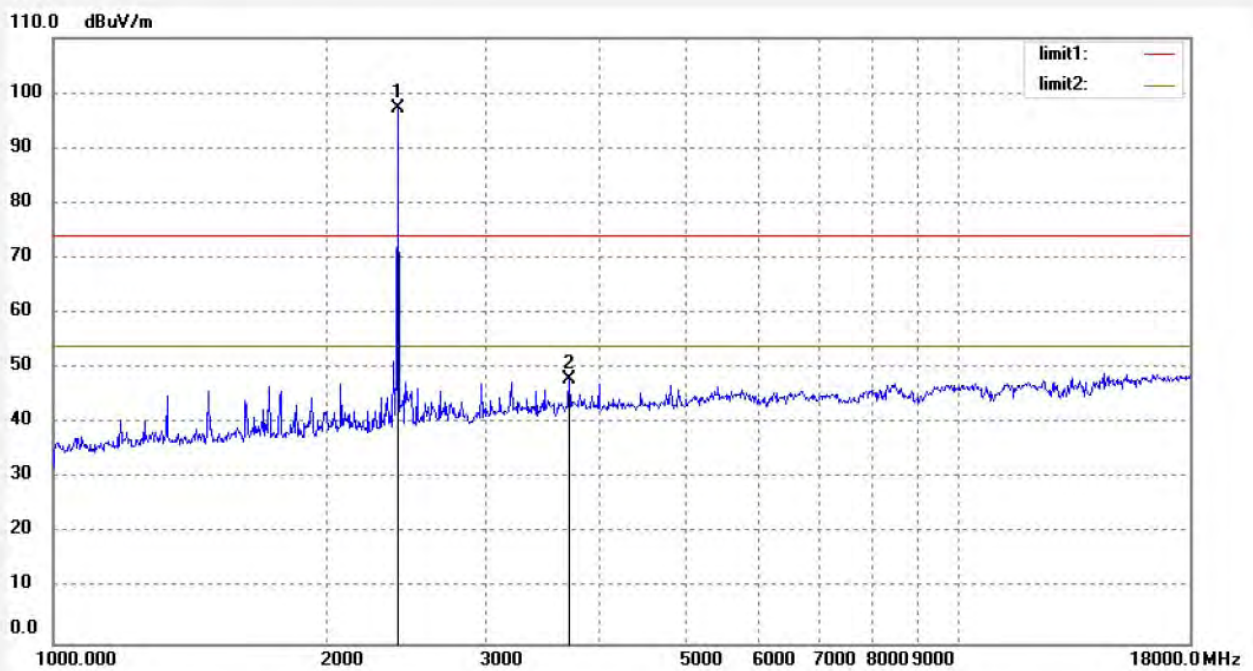

No.	Freq. (MHz)	Reading (dBuV/m)	Factor (dB)	Result (dBuV/m)	Limit (dBuV/m)	Margin (dB)	Detector	Height (cm)	Degree (deg.)	Remark
1	2402.153	57.91	39.28	97.19			peak	150	217	
2	3714.443	6.61	41.36	47.97	74.00	-26.03	peak	160	129	

Job No.: CLN65 XHUA #50

Standard: FCC PK

Test item: Radiation Test

Temp.(C)/Hum.(%) 23 C / 48 %

EUT: e-Screen ETX slot-in Android box

Mode: TX 2441MHz (8DPSK)

Model: RK3399

Manufacturer: Legamaster International B.V.

Polarization: Horizontal

Power Source: DC 12V

Date: 18/09/25/

Time: 13/58/58

Engineer Signature: WADE

Distance: 3m

Note: Report No.: ATE20181648

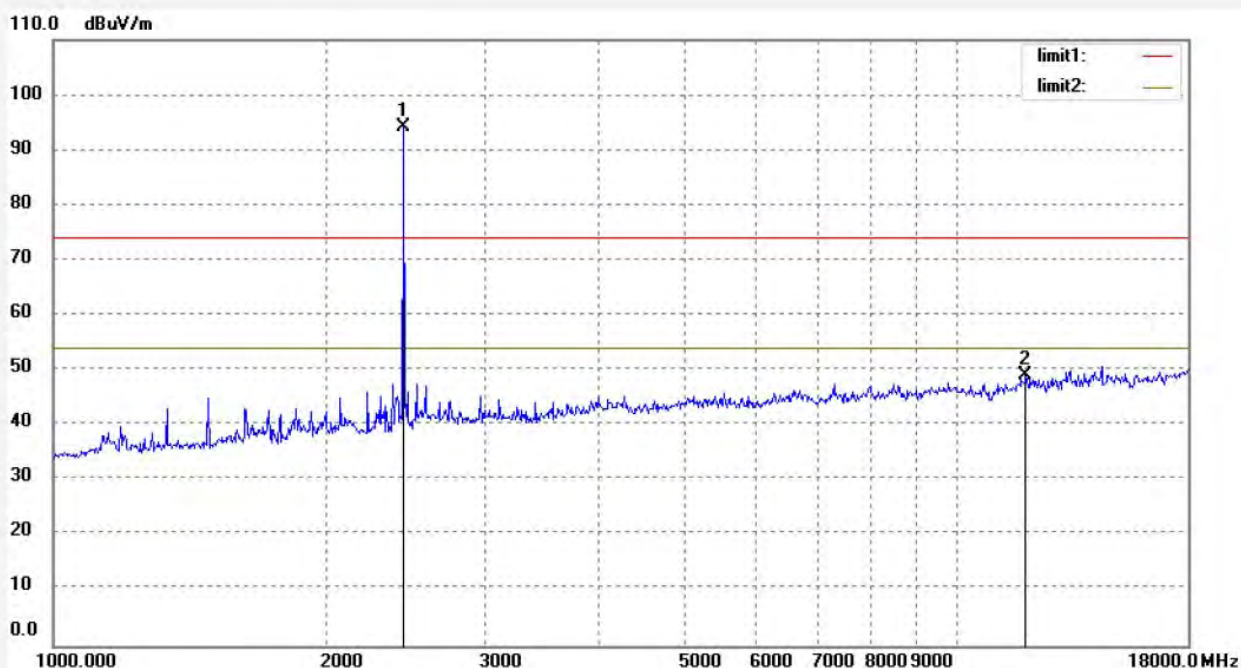

No.	Freq. (MHz)	Reading (dBuV/m)	Factor (dB)	Result (dBuV/m)	Limit (dBuV/m)	Margin (dB)	Detector	Height (cm)	Degree (deg.)	Remark
1	2441.051	54.74	39.46	94.20			peak	150	318	
2	11906.073	-4.57	53.74	49.17	74.00	-24.83	peak	200	127	



ACCURATE TECHNOLOGY CO., LTD.

F1,Bldg,A,Changyuan New Material Port Keyuan Rd,
Science & Industry Park,Nanshan Shenzhen,P.R.China

Site: 2# Chamber

Tel:+86-0755-26503290

Fax:+86-0755-26503396

Job No.: CLN65 XHUA #51

Standard: FCC PK

Test item: Radiation Test

Temp.(C)/Hum.(%) 23 C / 48 %

EUT: e-Screen ETX slot-in Android box

Mode: TX 2441MHz (8DPSK)

Model: RK3399

Manufacturer: Legamaster International B.V.

Polarization: Vertical

Power Source: DC 12V

Date: 18/09/25/

Time: 14/00/12

Engineer Signature: WADE

Distance: 3m

Note: Report No.: ATE20181648

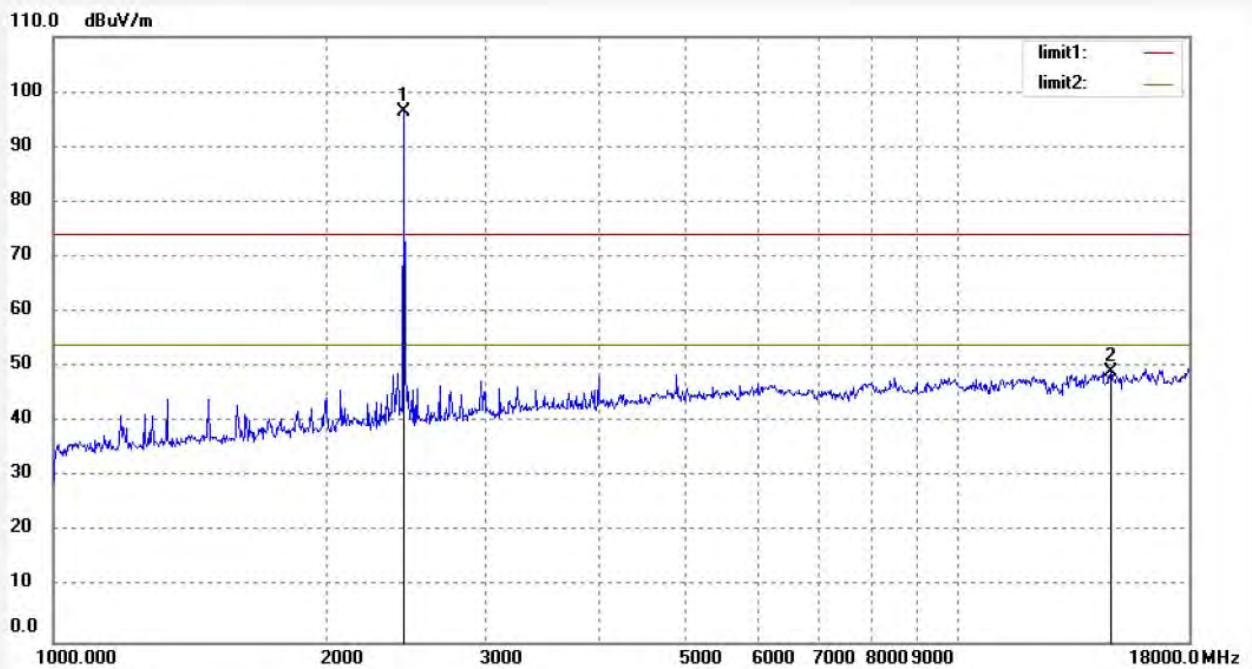

No.	Freq. (MHz)	Reading (dBuV/m)	Factor (dB)	Result (dBuV/m)	Limit (dBuV/m)	Margin (dB)	Detector	Height (cm)	Degree (deg.)	Remark
1	2441.051	57.01	39.46	96.47			peak	150	112	
2	14745.473	-10.59	59.81	49.22	74.00	-24.78	peak	200	128	



ACCURATE TECHNOLOGY CO., LTD.

F1,Bldg,A,Changyuan New Material Port Keyuan Rd,
Science & Industry Park,Nanshan Shenzhen,P.R.China

Site: 2# Chamber
Tel:+86-0755-26503290
Fax:+86-0755-26503396

Job No.: CLN65 XHUA #49	Polarization: Horizontal
Standard: FCC PK	Power Source: DC 12V
Test item: Radiation Test	Date: 18/09/25/
Temp.(C)/Hum.(%) 23 C / 48 %	Time: 13/57/38
EUT: e-Screen ETX slot-in Android box	Engineer Signature: WADE
Mode: TX 2480MHz (8DPSK)	Distance: 3m
Model: RK3399	
Manufacturer: Legamaster International B.V.	

Note: Report No.: ATE20181648

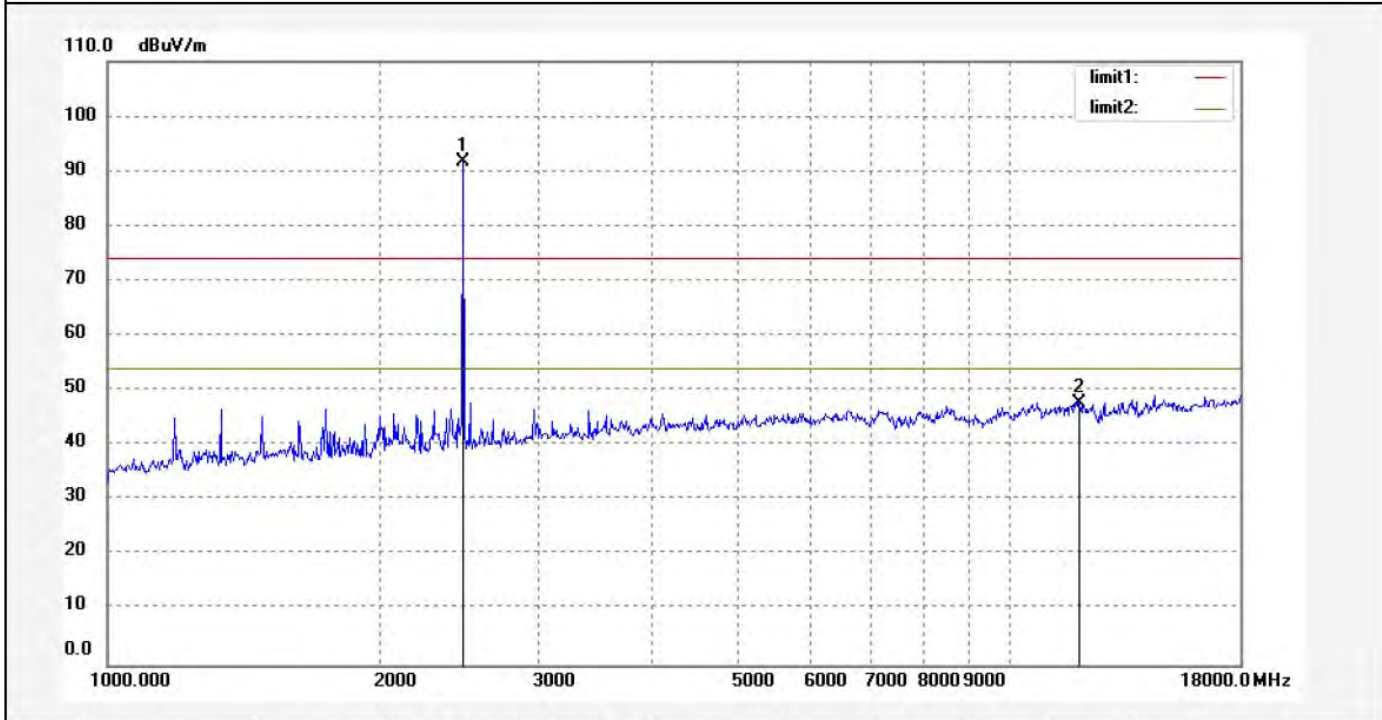

No.	Freq. (MHz)	Reading (dBuV/m)	Factor (dB)	Result (dBuV/m)	Limit (dBuV/m)	Margin (dB)	Detector	Height (cm)	Degree (deg.)	Remark
1	2480.310	52.11	39.61	91.72			peak	150	191	
2	11940.536	-6.00	53.85	47.85	74.00	-26.15	peak	200	218	



ACCURATE TECHNOLOGY CO., LTD.

F1,Bldg,A,Changyuan New Material Port Keyuan Rd,
Science & Industry Park,Nanshan Shenzhen,P.R.China

Site: 2# Chamber

Tel:+86-0755-26503290

Fax:+86-0755-26503396

Job No.: CLN65 XHUA #48	Polarization: Vertical
Standard: FCC PK	Power Source: DC 12V
Test item: Radiation Test	Date: 18/09/25/
Temp.(C)/Hum.(%) 23 C / 48 %	Time: 13/56/36
EUT: e-Screen ETX slot-in Android box	Engineer Signature: WADE
Mode: TX 2480MHz (8DPSK)	Distance: 3m
Model: RK3399	
Manufacturer: Legamaster International B.V.	

Note: Report No.: ATE20181648

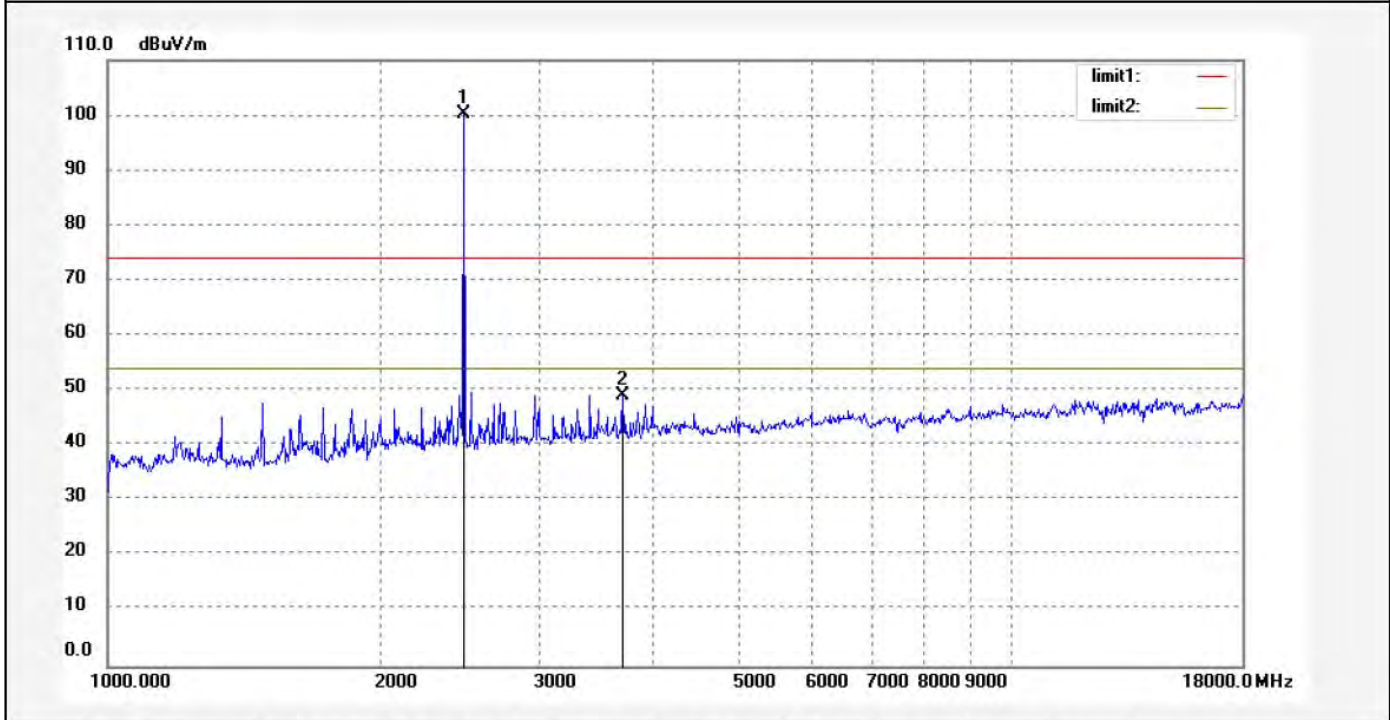

No.	Freq. (MHz)	Reading (dBuV/m)	Factor (dB)	Result (dBuV/m)	Limit (dBuV/m)	Margin (dB)	Detector	Height (cm)	Degree (deg.)	Remark
1	2480.310	60.52	39.61	100.13			peak	150	182	
2	3714.443	7.84	41.36	49.20	74.00	-24.80	peak	160	26	

11. BAND EDGE COMPLIANCE TEST

11.1. Block Diagram of Test Setup

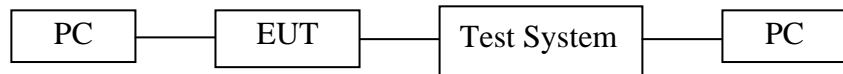

(EUT: e-Screen ETX slot-in Android box)

11.2. The Requirement For Section 15.247(d)

Section 15.247(d): In any 100 kHz bandwidth outside the frequency band in which the spread spectrum or digitally modulated intentional radiator is operating, the radio frequency power that is produced by the intentional radiator shall be at least 20 dB below that in the 100 kHz bandwidth within the band that contains the highest level of the desired power, based on either an RF conducted or a radiated measurement, provided the transmitter demonstrates compliance with the peak conducted power limits. If the transmitter complies with the conducted power limits based on the use of RMS averaging over a time interval, as permitted under paragraph (b)(3) of this section, the attenuation required under this paragraph shall be 30 dB instead of 20 dB. Attenuation below the general limits specified in Section 15.209(a) is not required. In addition, radiated emissions which fall in the restricted bands, as defined in Section 15.205(a), must also comply with the radiated emission limits specified in Section 15.209(a).

11.3. EUT Configuration on Measurement

The equipment are installed on the emission Measurement to meet the commission requirements and operating regulations in a manner which tends to maximize its emission characteristics in normal application.

11.4. Operating Condition of EUT

11.4.1. Setup the EUT and simulator as shown as Section 11.1.

11.4.2. Turn on the power of all equipment.

11.4.3. Let the EUT work in TX (Hopping off, Hopping on) modes measure it. The transmit frequency are 2402-2480MHz. We select 2402MHz, 2480MHz TX frequency to transmit.

11.5. Test Procedure

11.5.1. The transmitter output was connected to the spectrum analyzer via a low loss cable.

11.5.2. Set RBW of spectrum analyzer to 100 kHz and VBW to 300 kHz with convenient frequency span including 100 kHz bandwidth from band edge.

11.5.3. The band edges was measured and recorded.

11.6. Test Result

Frequency (MHz)	Result of Band Edge (dBc)	Limit of Band Edge (dBc)
GFSK		
2400.00	48.41	> 20dBc
2483.50	49.50	> 20dBc
Π/4 DQPSK Mode		
2400.00	46.21	> 20dBc
2483.50	44.42	> 20dBc
8DPSK		
2400.00	39.70	> 20dBc
2483.50	46.46	> 20dBc

Note: Both hopping-on mode and hopping-off mode had been pre-tested, and only the worst case was recorded in the test report.

The spectrum analyzer plots are attached as below.

GFSK Mode

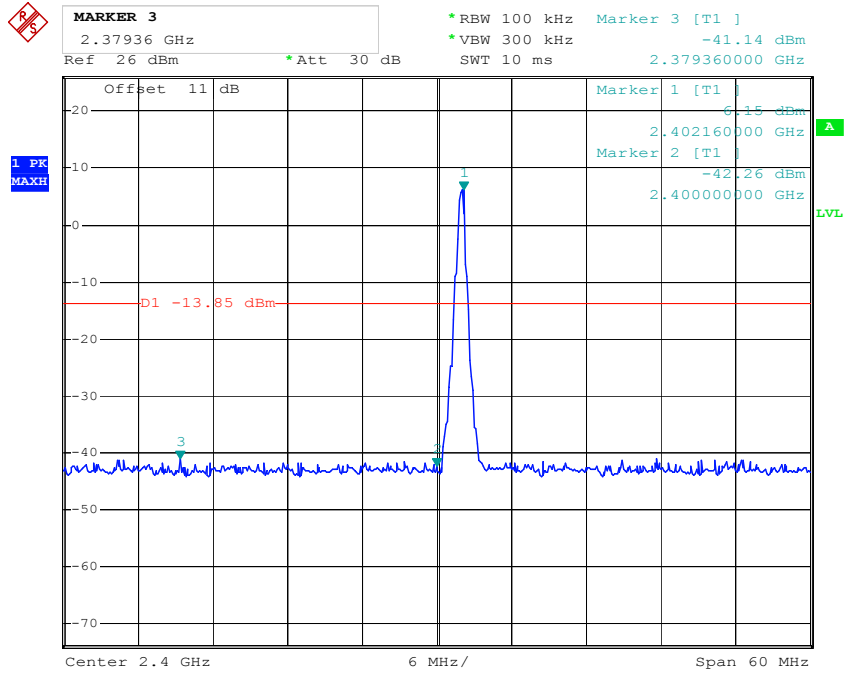

Comment A:
Date: 6.SEP.2018 17:14:19

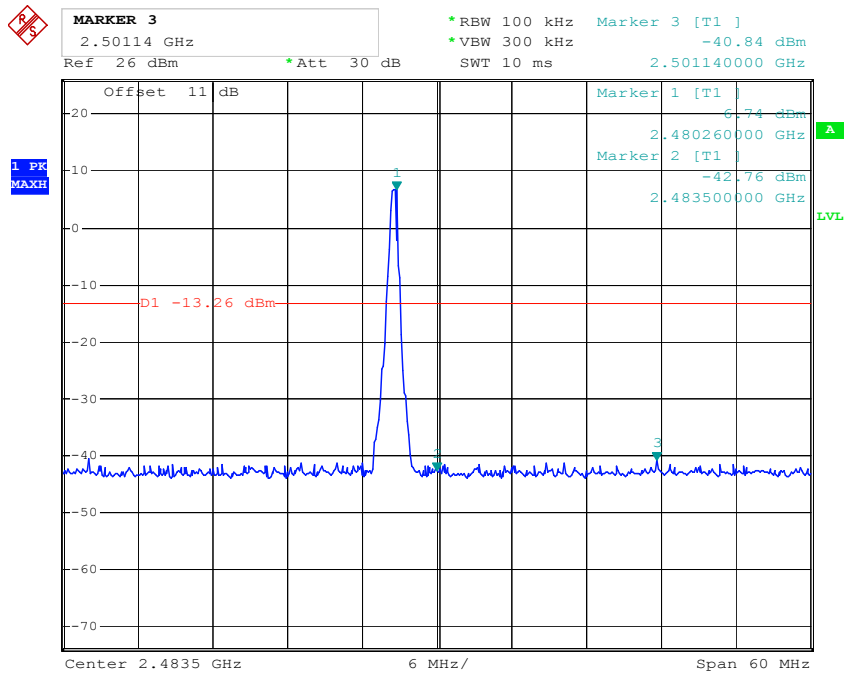

Comment A:
Date: 6.SEP.2018 17:12:46

Π/4-DQPSK Mode

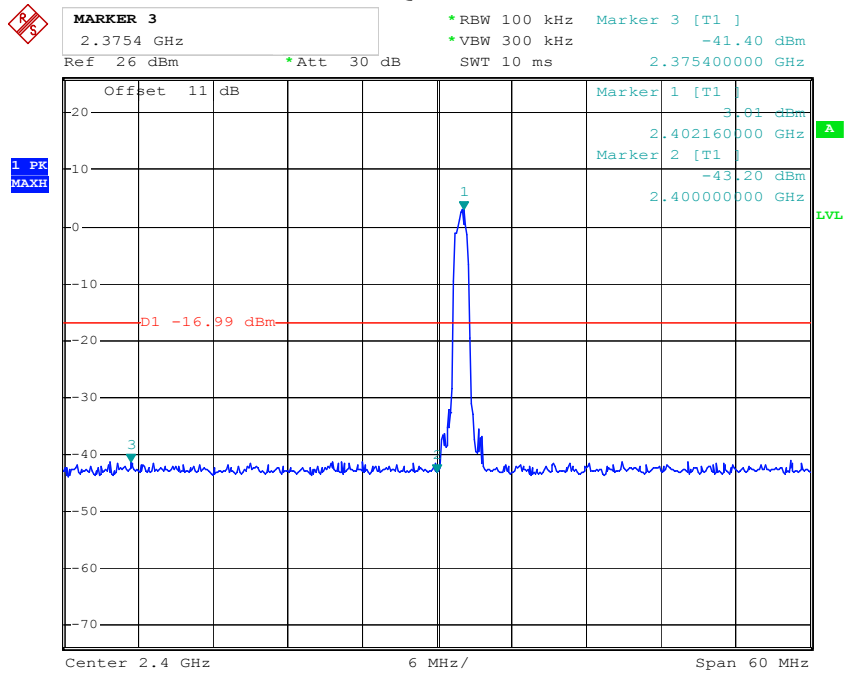

Comment A:
 Date: 6.SEP.2018 17:16:34

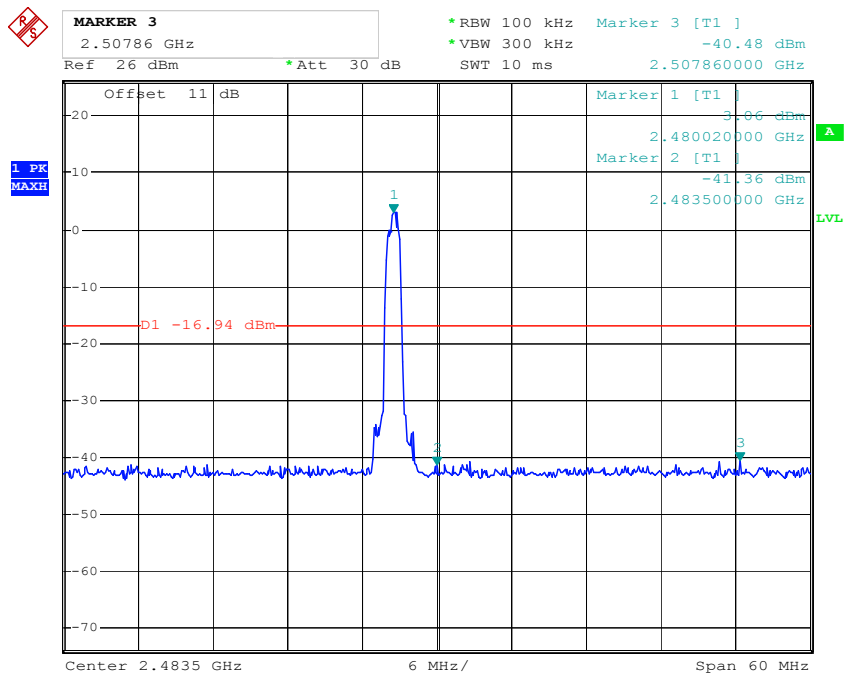

Comment A:
 Date: 6.SEP.2018 17:11:01

8DPSK Mode

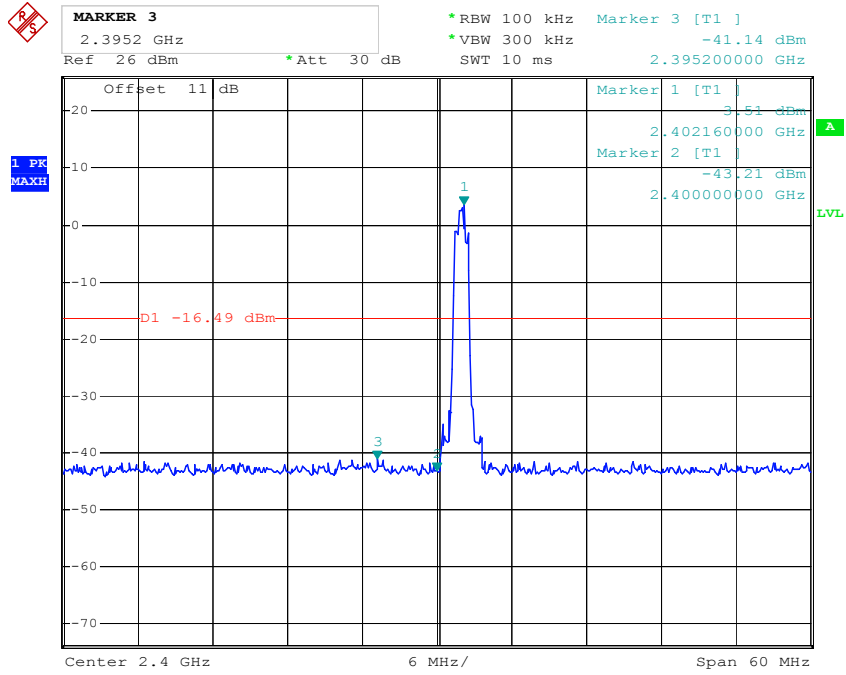

Comment A:
 Date: 6.SEP.2018 17:17:51

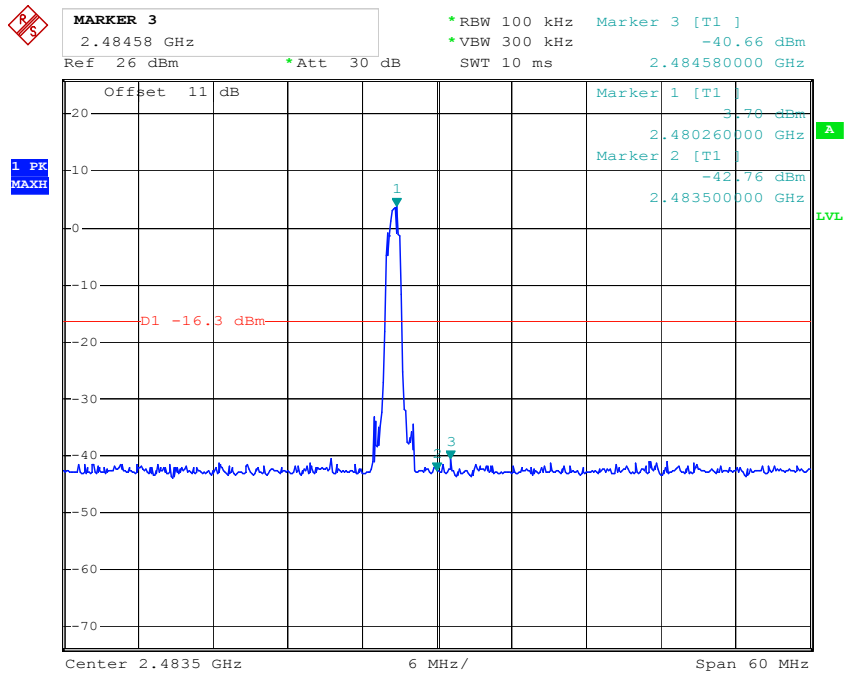

Comment A:
 Date: 6.SEP.2018 17:08:28

Radiated Band Edge Result

Note:

1. Emissions attenuated more than 20 dB below the permissible value are not reported.
2. The field strength is calculated by adding the antenna factor, high pass filter loss(if used) and cable loss, and subtracting the amplifier gain(if any)from the measured reading. The basic equation calculation is as follows:

Result = Reading + Corrected Factor

3. Display the measurement of peak values.

Test Procedure:

The EUT and its simulators are placed on a turntable, which is 1.5 meter high above ground(Above 1GHz). The turntable can rotate 360 degrees to determine the position of the maximum emission level. EUT is set 3.0 meters away from the receiving antenna, which is mounted on an antenna tower. The antenna can be moved up and down between 1.0 meter and 4 meters to find out the maximum emission level. Broadband antenna (calibrated bi-log antenna) is used as receiving antenna. Both horizontal and vertical polarizations of the antenna are set on measurement. In order to find the maximum emission levels, all of the EUT location must be manipulated according to ANSI C63.10:2013 on radiated emission measurement. The EUT was tested in 3 orthogonal planes.

Let the EUT work in TX (Hopping off, Hopping on) modes measure it.
We select 2402MHz, 2480MHz TX frequency to transmit(Hopping off mode).
We select 2402-2480MHz TX frequency to transmit(Hopping on mode).

During the radiated emission test, the spectrum analyzer was set with the following configurations:

- 1.The resolution bandwidth of test receiver/spectrum analyzer is 1MHz and video bandwidth is 3MHz for peak measurement with peak detector at frequency above 1GHz.
- 2.The resolution bandwidth of test receiver/spectrum analyzer is 1MHz and video bandwidth is 10Hz for Average measurement with peak detection at frequency above 1GHz.
- 3.All modes of operation were investigated and the worst-case emissions are reported.

Note:

- 1.We tested BDR & EDR mode and recorded the worst case data (GFSK mode & 8DPSK mode) for Non-hopping mode.**
- 2.We tested BDR & EDR mode and recorded the worst case data (GFSK mode) for hopping mode.**

Non-hopping mode

ACCURATE TECHNOLOGY CO., LTD.

 F1,Bldg,A,Changyuan New Material Port Keyuan Rd,
 Science & Industry Park,Nanshan Shenzhen,P.R.China

Site: 2# Chamber

Tel:+86-0755-26503290

Fax:+86-0755-26503396

Job No.: CLN65 XHUA #65

Standard: FCC PK

Test item: Radiation Test

Temp.(C)/Hum.(%) 23 C / 48 %

EUT: e-Screen ETX slot-in Android box

Mode: TX 2402MHz (GFSK)

Model: RK3399

Manufacturer: Legamaster International B.V.

Polarization: Horizontal

Power Source: DC 12V

Date: 18/09/25/

Time: 14/25/47

Engineer Signature: WADE

Distance: 3m

Note: Report No.: ATE20181648

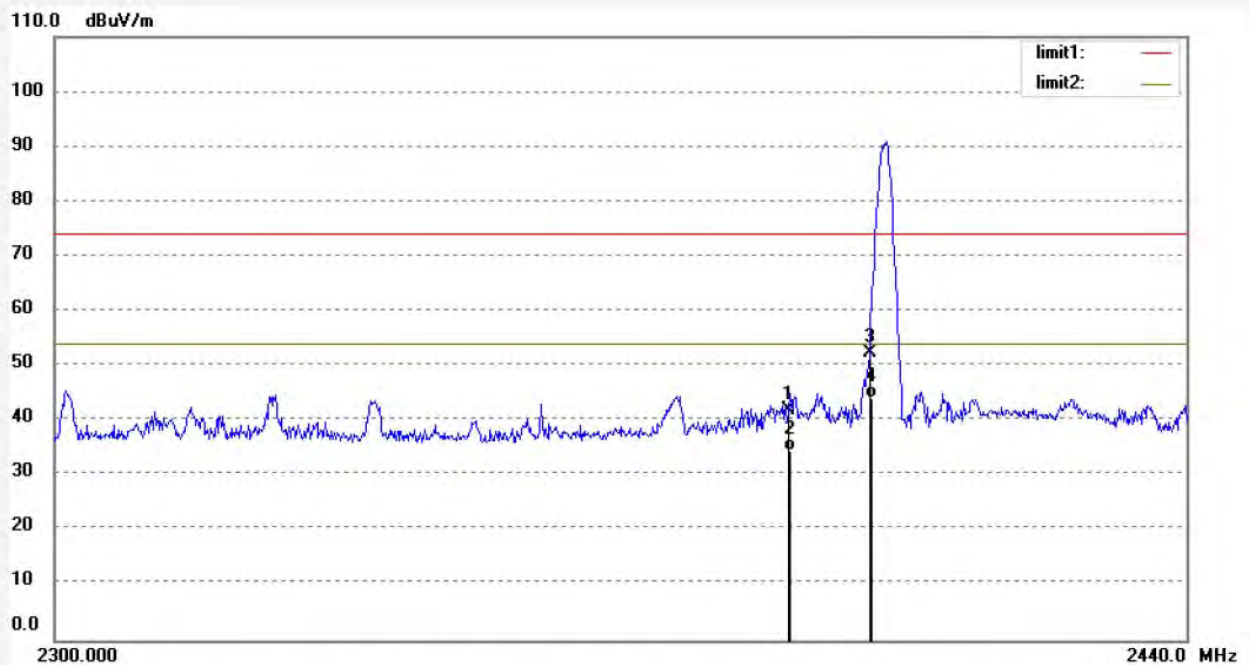

No.	Freq. (MHz)	Reading (dBuV/m)	Factor (dB)	Result (dBuV/m)	Limit (dBuV/m)	Margin (dB)	Detector	Height (cm)	Degree (deg.)	Remark
1	2390.000	41.11	0.79	41.90	74.00	-32.10	peak	150	128	
2	2390.000	33.85	0.79	34.64	54.00	-19.36	AVG	150	130	
3	2400.000	51.51	0.88	52.39	74.00	-21.61	peak	150	219	
4	2400.000	43.28	0.88	44.16	54.00	-9.84	AVG	150	220	

Job No.: CLN65 XHUA #64

Standard: FCC PK

Test item: Radiation Test

Temp.(C)/Hum.(%) 23 C / 48 %

EUT: e-Screen ETX slot-in Android box

Mode: TX 2402MHz (GFSK)

Model: RK3399

Manufacturer: Legamaster International B.V.

Polarization: Vertical

Power Source: DC 12V

Date: 18/09/25/

Time: 14/24/37

Engineer Signature: WADE

Distance: 3m

Note: Report No.: ATE20181648

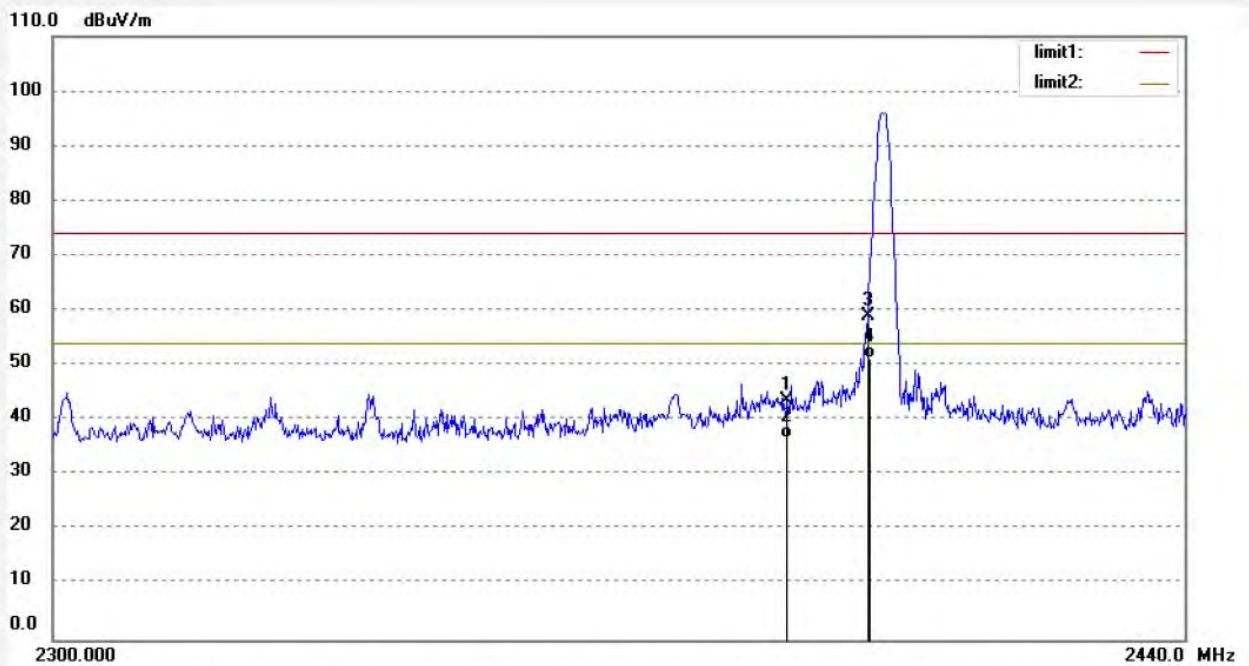

No.	Freq. (MHz)	Reading (dBuV/m)	Factor (dB)	Result (dBuV/m)	Limit (dBuV/m)	Margin (dB)	Detector	Height (cm)	Degree (deg.)	Remark
1	2390.000	42.70	0.79	43.49	74.00	-30.51	peak	150	121	
2	2390.000	35.99	0.79	36.78	54.00	-17.22	AVG	150	120	
3	2400.000	58.12	0.88	59.00	74.00	-15.00	peak	150	216	
4	2400.000	50.36	0.88	51.24	54.00	-2.76	AVG	150	215	



ACCURATE TECHNOLOGY CO., LTD.

F1,Bldg,A,Changyuan New Material Port Keyuan Rd,
Science & Industry Park,Nanshan Shenzhen,P.R.China

Site: 2# Chamber

Tel:+86-0755-26503290

Fax:+86-0755-26503396

Job No.: CLN65 XHUA #70

Standard: FCC PK

Test item: Radiation Test

Temp.(C)/Hum.(%) 23 C / 48 %

EUT: e-Screen ETX slot-in Android box

Mode: TX 2480MHz (GFSK)

Model: RK3399

Manufacturer: Legamaster International B.V.

Polarization: Horizontal

Power Source: DC 12V

Date: 18/09/25/

Time: 14/32/13

Engineer Signature: WADE

Distance: 3m

Note: Report No.: ATE20181648

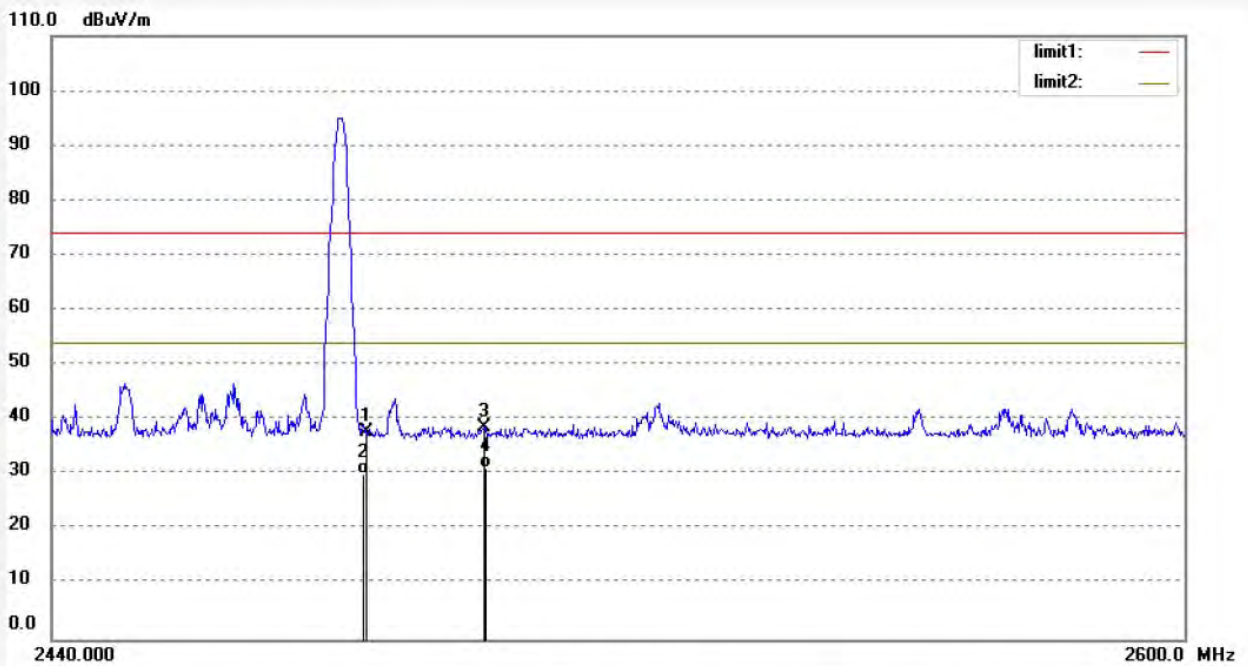

No.	Freq. (MHz)	Reading (dBuV/m)	Factor (dB)	Result (dBuV/m)	Limit (dBuV/m)	Margin (dB)	Detector	Height (cm)	Degree (deg.)	Remark
1	2483.500	36.85	1.10	37.95	74.00	-36.05	peak	150	187	
2	2483.500	29.00	1.10	30.10	54.00	-23.90	AVG	150	190	
3	2500.000	37.45	1.10	38.55	74.00	-35.45	peak	160	38	
4	2500.000	30.11	1.10	31.21	54.00	-22.79	AVG	160	40	

ACCURATE TECHNOLOGY CO., LTD.

 F1,Bldg,A,Changyuan New Material Port Keyuan Rd,
 Science & Industry Park,Nanshan Shenzhen,P.R.China

Site: 2# Chamber

Tel:+86-0755-26503290

Fax:+86-0755-26503396

Job No.: CLN65 XHUA #71	Polarization: Vertical
Standard: FCC PK	Power Source: DC 12V
Test item: Radiation Test	Date: 18/09/25/
Temp.(C)/Hum.(%) 23 C / 48 %	Time: 14/33/07
EUT: e-Screen ETX slot-in Android box	Engineer Signature: WADE
Mode: TX 2480MHz (GFSK)	Distance: 3m
Model: RK3399	
Manufacturer: Legamaster International B.V.	

Note: Report No.: ATE20181648

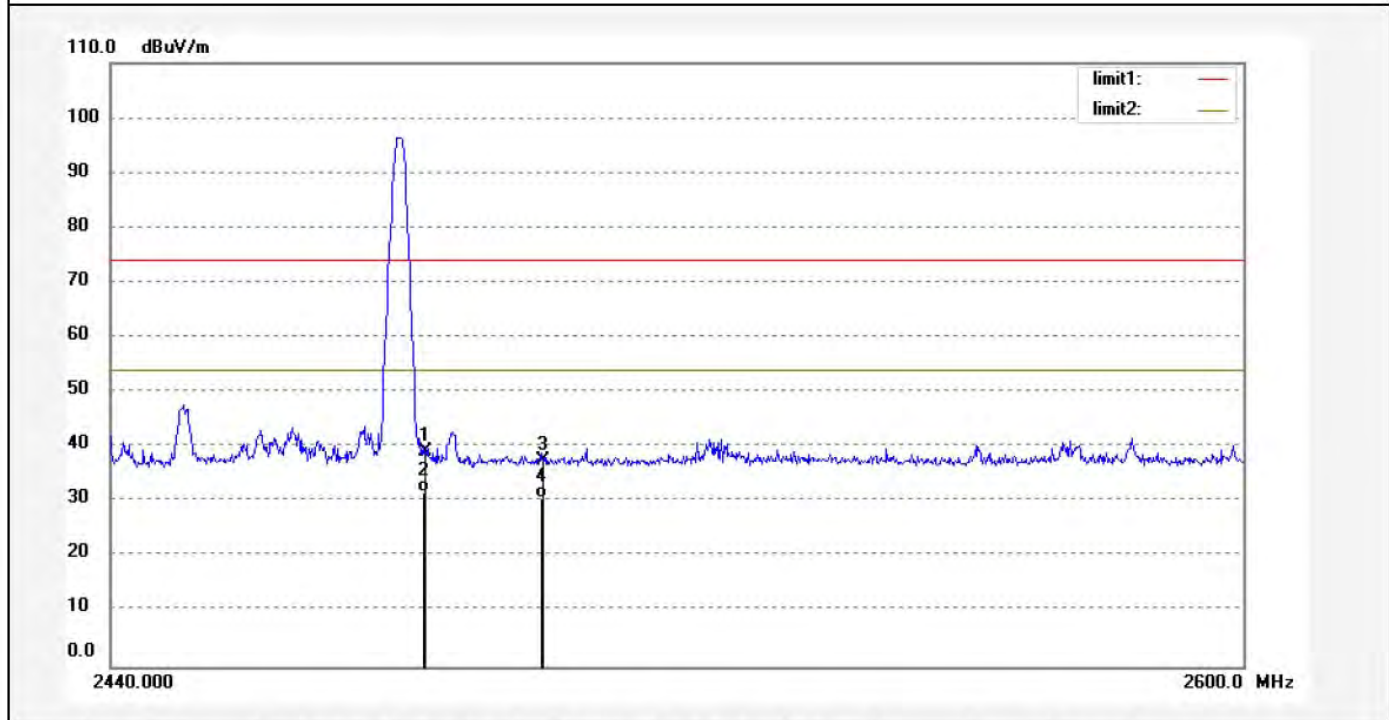

No.	Freq. (MHz)	Reading (dBuV/m)	Factor (dB)	Result (dBuV/m)	Limit (dBuV/m)	Margin (dB)	Detector	Height (cm)	Degree (deg.)	Remark
1	2483.500	37.99	1.10	39.09	74.00	-34.91	peak	150	219	
2	2483.500	30.78	1.10	31.88	54.00	-22.12	AVG	150	220	
3	2500.000	36.41	1.10	37.51	74.00	-36.49	peak	160	238	
4	2500.000	29.47	1.10	30.57	54.00	-23.43	AVG	160	240	

Job No.: CLN65 XHUA #66

Standard: FCC PK

Test item: Radiation Test

Temp.(C)/Hum.(%) 23 C / 48 %

EUT: e-Screen ETX slot-in Android box

Mode: TX 2402MHz (8DPSK)

Model: RK3399

Manufacturer: Legamaster International B.V.

Polarization: Horizontal

Power Source: DC 12V

Date: 18/09/25/

Time: 14/27/30

Engineer Signature: WADE

Distance: 3m

Note: Report No.: ATE20181648

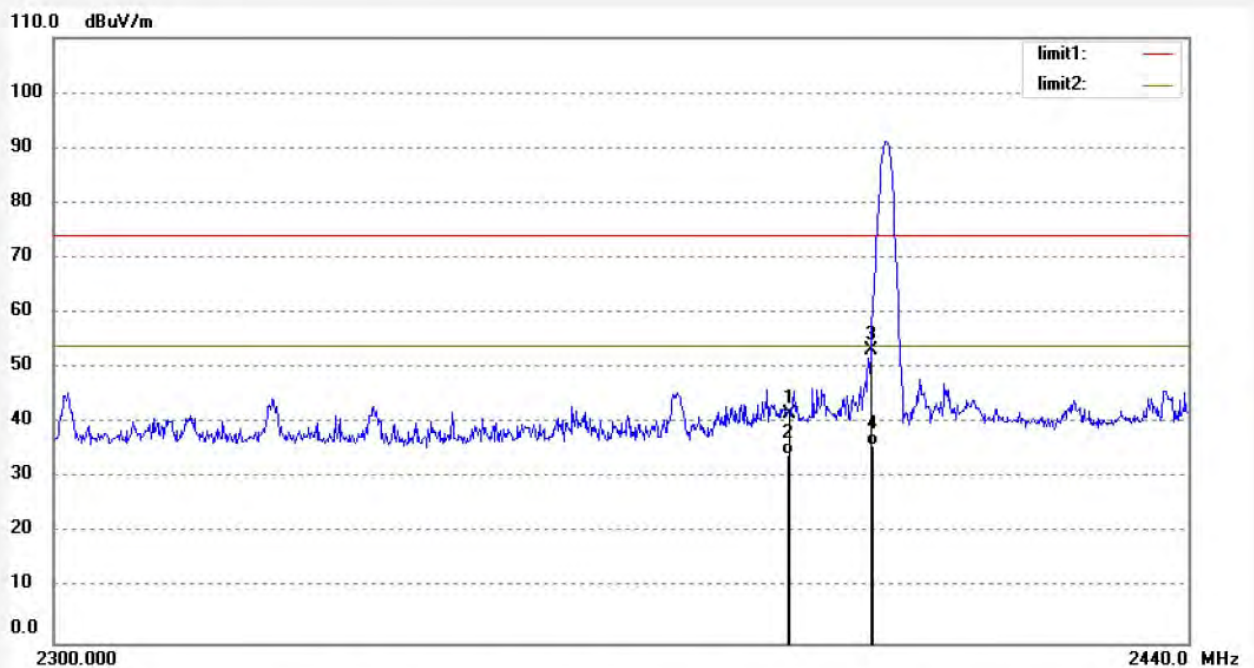

No.	Freq. (MHz)	Reading (dBuV/m)	Factor (dB)	Result (dBuV/m)	Limit (dBuV/m)	Margin (dB)	Detector	Height (cm)	Degree (deg.)	Remark
1	2390.000	40.78	0.79	41.57	74.00	-32.43	peak	150	211	
2	2390.000	33.57	0.79	34.36	54.00	-19.64	AVG	150	210	
3	2400.000	52.47	0.88	53.35	74.00	-20.65	peak	150	200	
4	2400.000	35.01	0.88	35.89	54.00	-18.11	AVG	150	198	

Job No.: CLN65 XHUA #67

Standard: FCC PK

Test item: Radiation Test

Temp.(C)/Hum.(%) 23 C / 48 %

EUT: e-Screen ETX slot-in Android box

Mode: TX 2402MHz (8DPSK)

Model: RK3399

Manufacturer: Legamaster International B.V.

Polarization: Vertical

Power Source: DC 12V

Date: 18/09/25/

Time: 14/28/15

Engineer Signature: WADE

Distance: 3m

Note: Report No.: ATE20181648

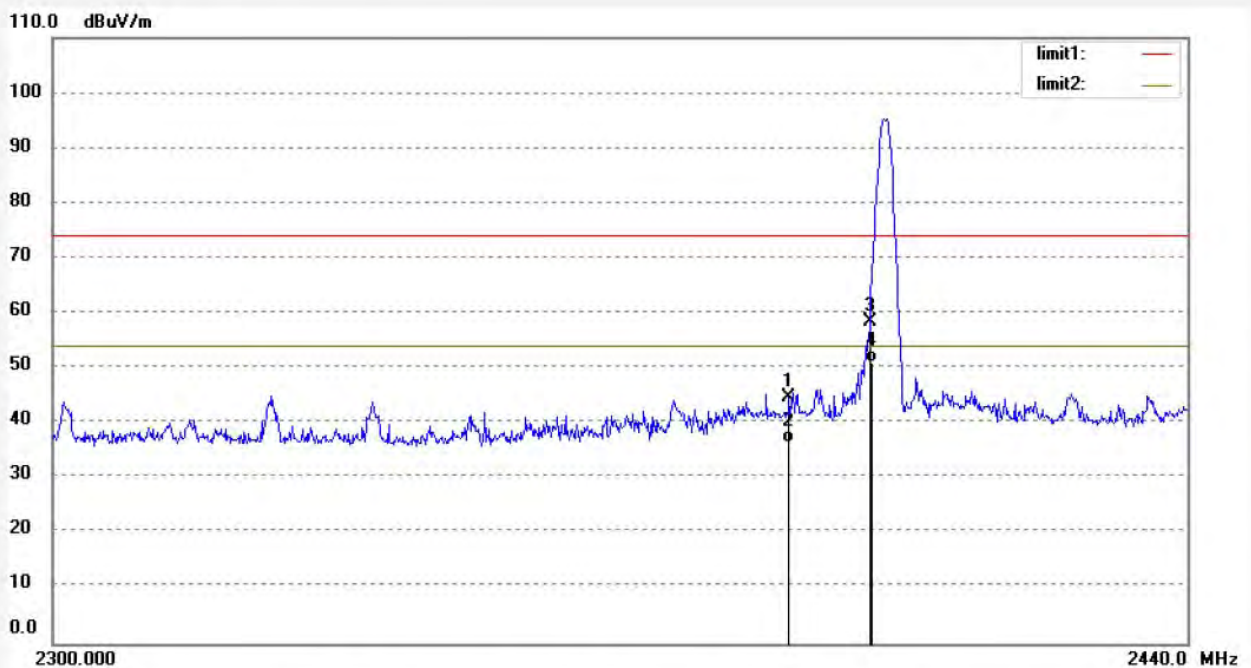

No.	Freq. (MHz)	Reading (dBuV/m)	Factor (dB)	Result (dBuV/m)	Limit (dBuV/m)	Margin (dB)	Detector	Height (cm)	Degree (deg.)	Remark
1	2390.000	43.80	0.79	44.59	74.00	-29.41	peak	150	217	
2	2390.000	35.74	0.79	36.53	54.00	-17.47	AVG	150	220	
3	2400.000	57.64	0.88	58.52	74.00	-15.48	peak	150	129	
4	2400.000	50.13	0.88	51.01	54.00	-2.99	AVG	150	130	



ACCURATE TECHNOLOGY CO., LTD.

F1,Bldg,A,Changyuan New Material Port Keyuan Rd,
Science & Industry Park,Nanshan Shenzhen,P.R.China

Site: 2# Chamber

Tel:+86-0755-26503290

Fax:+86-0755-26503396

Job No.: CLN65 XHUA #69	Polarization: Horizontal
Standard: FCC PK	Power Source: DC 12V
Test item: Radiation Test	Date: 18/09/25/
Temp.(C)/Hum.(%) 23 C / 48 %	Time: 14/30/52
EUT: e-Screen ETX slot-in Android box	Engineer Signature: WADE
Mode: TX 2480MHz (8DPSK)	Distance: 3m
Model: RK3399	
Manufacturer: Legamaster International B.V.	

Note: Report No.: ATE20181648

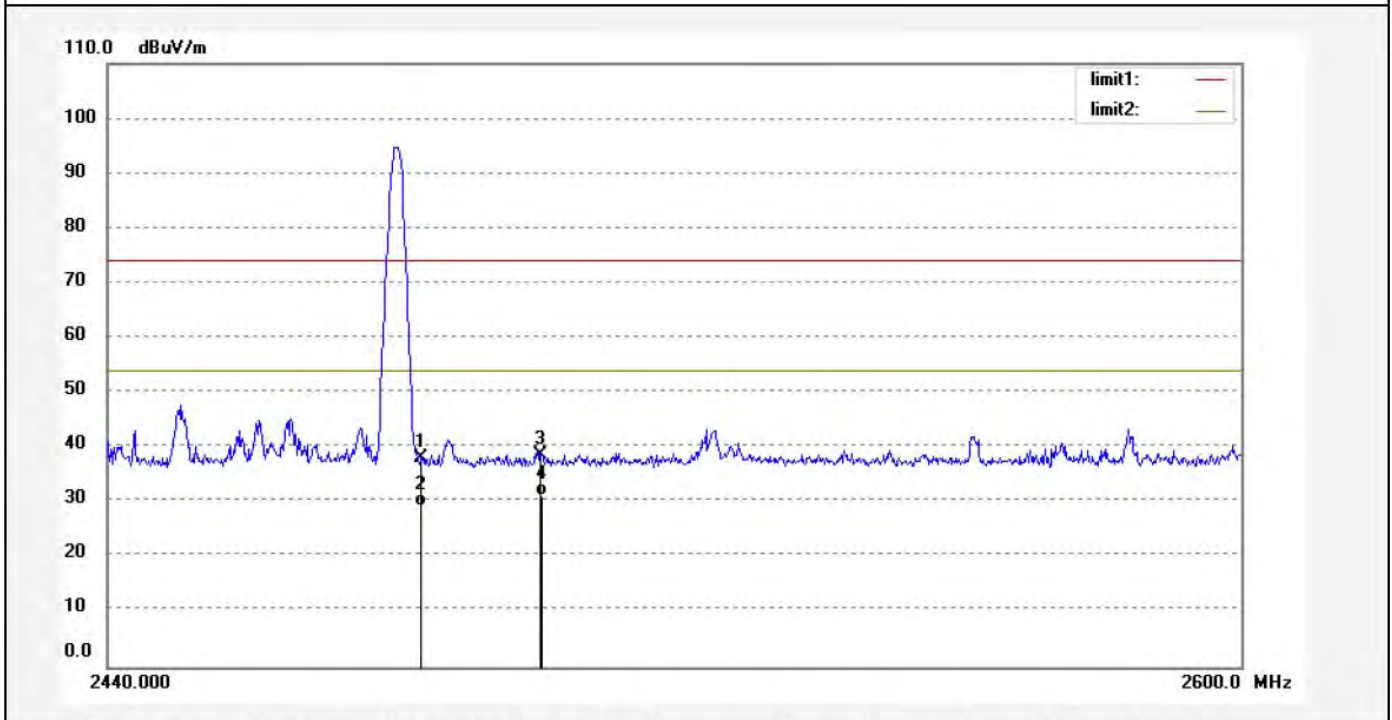

No.	Freq. (MHz)	Reading (dBuV/m)	Factor (dB)	Result (dBuV/m)	Limit (dBuV/m)	Margin (dB)	Detector	Height (cm)	Degree (deg.)	Remark
1	2483.500	36.93	1.10	38.03	74.00	-35.97	peak	160	217	
2	2483.500	28.30	1.10	29.40	54.00	-24.60	AVG	160	219	
3	2500.000	37.54	1.10	38.64	74.00	-35.36	peak	150	51	
4	2500.000	30.21	1.10	31.31	54.00	-22.69	AVG	150	50	



ACCURATE TECHNOLOGY CO., LTD.

F1,Bldg,A,Changyuan New Material Port Keyuan Rd,
Science & Industry Park,Nanshan Shenzhen,P.R.China

Site: 2# Chamber

Tel:+86-0755-26503290

Fax:+86-0755-26503396

Job No.: CLN65 XHUA #68	Polarization: Vertical
Standard: FCC PK	Power Source: DC 12V
Test item: Radiation Test	Date: 18/09/25/
Temp.(C)/Hum.(%) 23 C / 48 %	Time: 14/30/00
EUT: e-Screen ETX slot-in Android box	Engineer Signature: WADE
Mode: TX 2480MHz (8DPSK)	Distance: 3m
Model: RK3399	
Manufacturer: Legamaster International B.V.	

Note: Report No.: ATE20181648

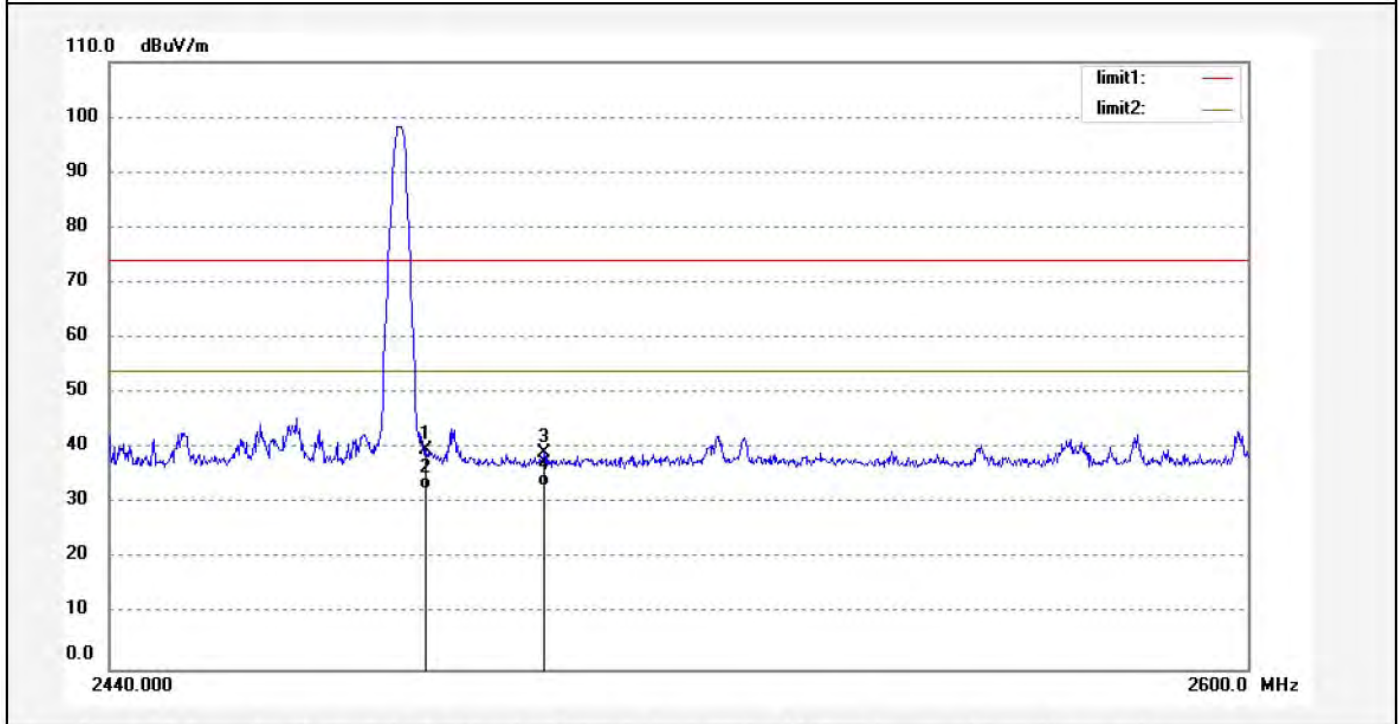

No.	Freq. (MHz)	Reading (dBuV/m)	Factor (dB)	Result (dBuV/m)	Limit (dBuV/m)	Margin (dB)	Detector	Height (cm)	Degree (deg.)	Remark
1	2483.500	38.63	1.10	39.73	74.00	-34.27	peak	150	181	
2	2483.500	31.59	1.10	32.69	54.00	-21.31	AVG	150	180	
3	2500.000	38.11	1.10	39.21	74.00	-34.79	peak	150	235	
4	2500.000	31.92	1.10	33.02	54.00	-20.98	AVG	150	236	

Hopping mode



ACCURATE TECHNOLOGY CO., LTD.

F1,Bldg,A,Changyuan New Material Port Keyuan Rd,
Science & Industry Park,Nanshan Shenzhen,P.R.China

Site: 1# Chamber

Tel:+86-0755-26503290

Fax:+86-0755-26503396

Job No.: FRANK2018A #169

Standard: FCC PK

Test item: Radiation Test

Temp.(C)/Hum.(%) 25 C / 55 %

EUT: e-Screen ETX slot-in Android box

Mode: HOPPING(GFSK)

Model: RK3399

Manufacturer: Legamaster International B.V.

Polarization: Horizontal

Power Source: DC 12V

Date: 2018/09/25

Time: 13:55:13

Engineer Signature: Frank

Distance: 3m

Note: Report NO.:ATE20181648

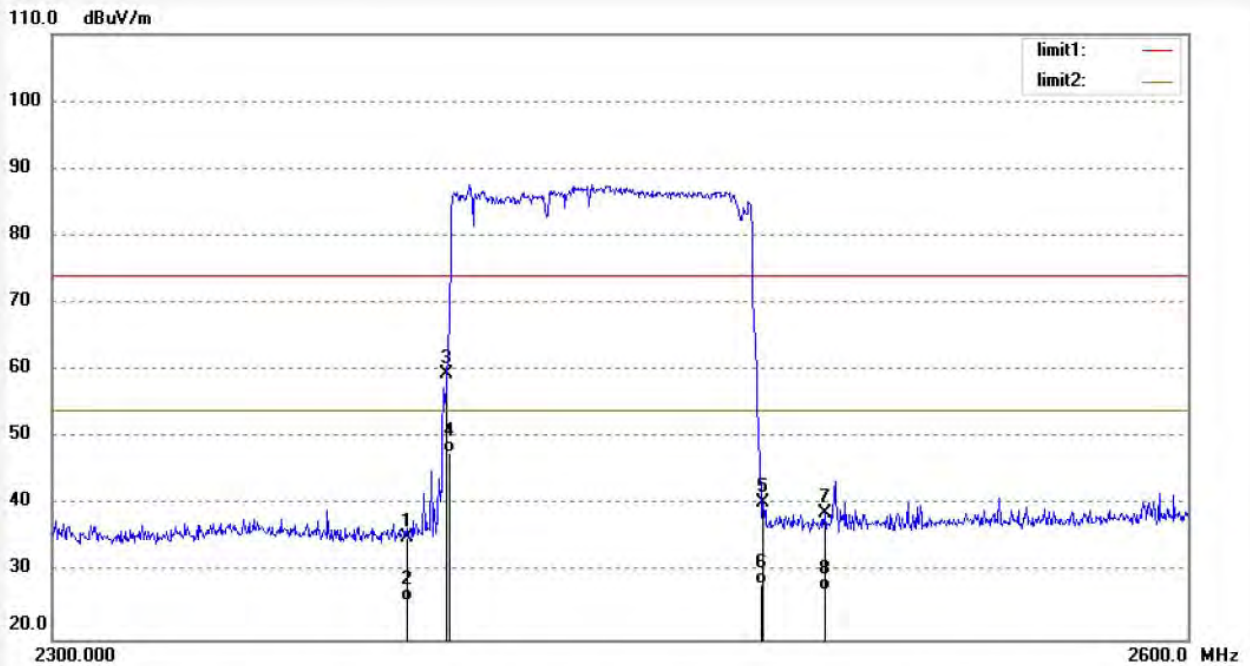

No.	Freq. (MHz)	Reading (dBuV/m)	Factor (dB)	Result (dBuV/m)	Limit (dBuV/m)	Margin (dB)	Detector	Height (cm)	Degree (deg.)	Remark
1	2390.000	39.40	-4.32	35.08	74.00	-38.92	peak	200	138	
2	2390.000	30.12	-4.32	25.80	54.00	-28.20	AVG	200	94	
3	2400.000	63.70	-4.27	59.43	74.00	-14.57	peak	200	251	
4	2400.000	52.12	-4.27	47.85	54.00	-6.15	AVG	200	103	
5	2483.500	44.19	-3.89	40.30	74.00	-33.70	peak	250	158	
6	2483.500	32.12	-3.89	28.23	54.00	-25.77	AVG	250	149	
7	2500.000	42.57	-3.81	38.76	74.00	-35.24	peak	250	201	
8	2500.000	31.15	-3.81	27.34	54.00	-26.66	AVG	200	321	



ACCURATE TECHNOLOGY CO., LTD.

F1,Bldg,A,Changyuan New Material Port Keyuan Rd,
Science & Industry Park,Nanshan Shenzhen,P.R.China

Site: 1# Chamber

Tel:+86-0755-26503290

Fax:+86-0755-26503396

Job No.: FRANK2018A #168	Polarization: Vertical
Standard: FCC PK	Power Source: DC 12V
Test item: Radiation Test	Date: 2018/09/25
Temp.(C)/Hum.(%) 25 C / 55 %	Time: 13:52:55
EUT: e-Screen ETX slot-in Android box	Engineer Signature: Frank
Mode: HOPPING(GFSK)	Distance: 3m
Model: RK3399	
Manufacturer: Legamaster International B.V.	

Note: Report NO.:ATE20181648

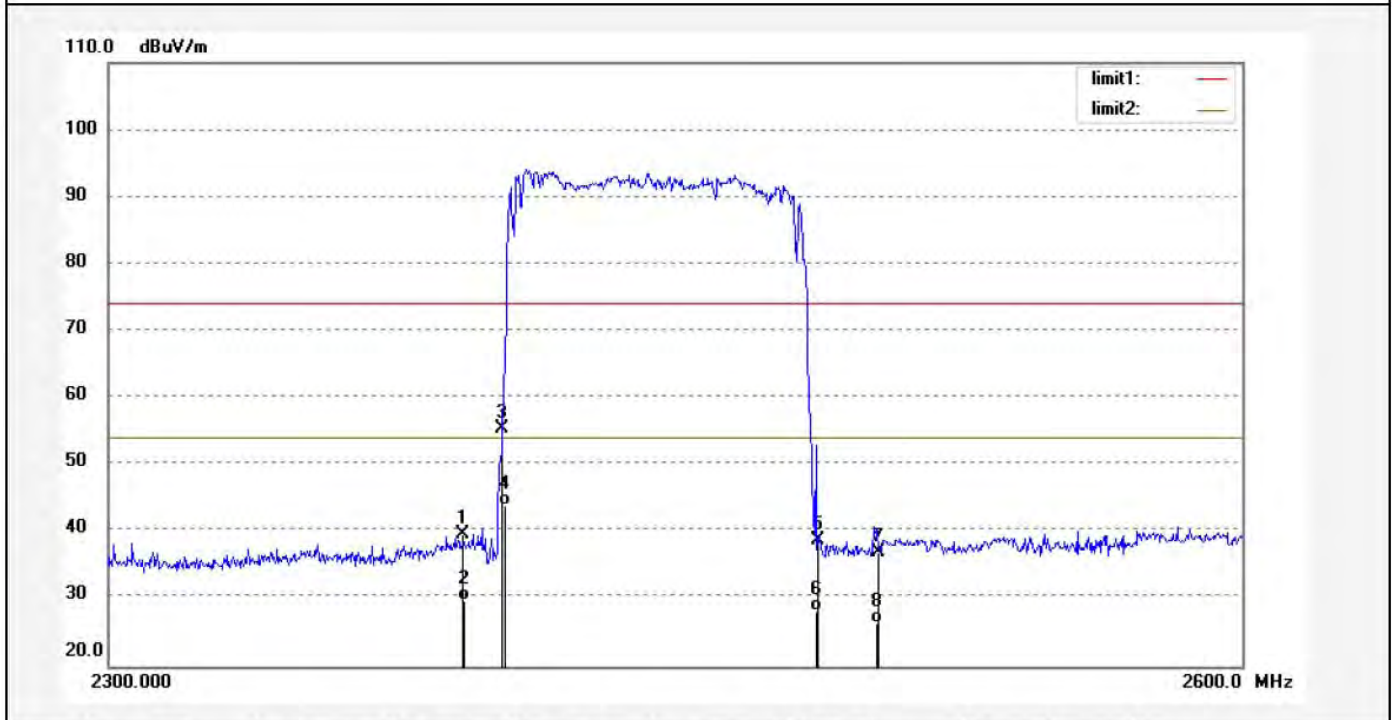

No.	Freq. (MHz)	Reading (dBuV/m)	Factor (dB)	Result (dBuV/m)	Limit (dBuV/m)	Margin (dB)	Detector	Height (cm)	Degree (deg.)	Remark
1	2390.000	43.95	-4.32	39.63	74.00	-34.37	peak	250	121	
2	2390.000	34.12	-4.32	29.80	54.00	-24.20	AVG	250	13	
3	2400.000	59.68	-4.27	55.41	74.00	-18.59	peak	250	101	
4	2400.000	48.15	-4.27	43.88	54.00	-10.12	AVG	200	127	
5	2483.500	42.62	-3.89	38.73	74.00	-35.27	peak	200	195	
6	2483.500	32.15	-3.89	28.26	54.00	-25.74	AVG	200	125	
7	2500.000	40.83	-3.81	37.02	74.00	-36.98	peak	200	111	
8	2500.000	30.12	-3.81	26.31	54.00	-27.69	AVG	250	320	

12.ANTENNA REQUIREMENT

12.1.The Requirement

According to Section 15.203, an intentional radiator shall be designed to ensure that no antenna other than that furnished by the responsible party shall be used with the device.

12.2.Antenna Construction

The module must contain a permanently attached antenna, or contain a unique antenna connector, and be marketed and operated only with specific antenna(s), per Sections 15.203, 15.204(b), 15.204(c), 15.212(a), 2.929(b); The Antenna gain of EUT is 2dBi. Therefore, the equipment complies with the antenna requirement.

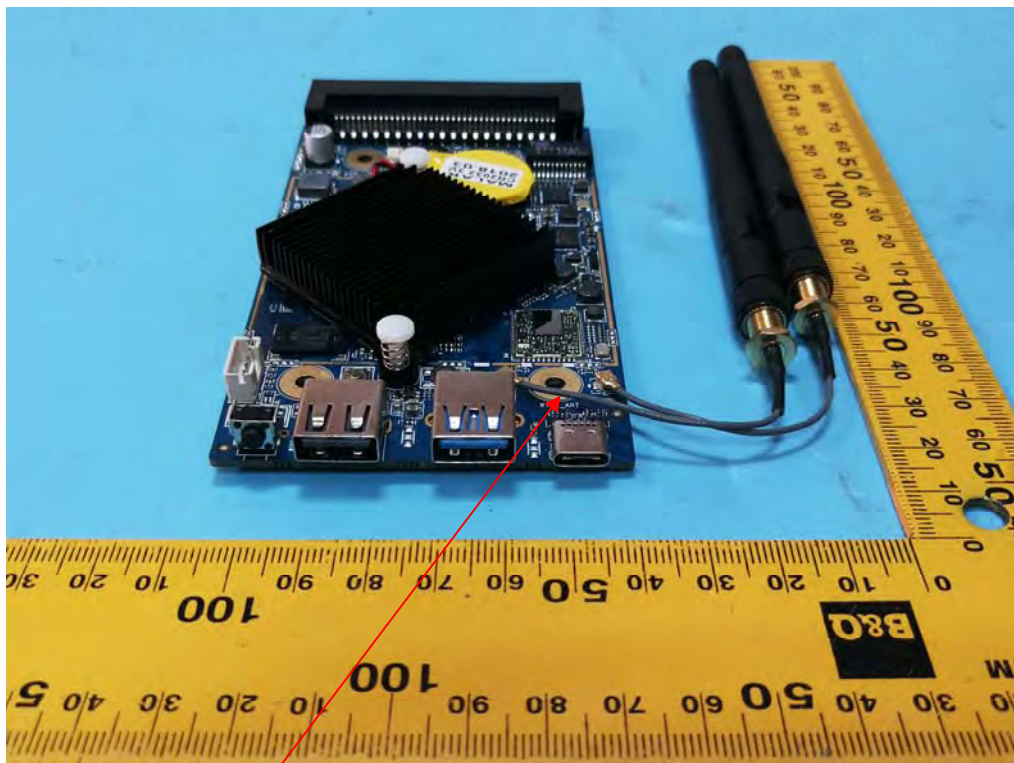

Antenna