

FCC SAR EVALUATION REPORT

In accordance with the requirements of
FCC 47 CFR Part 2(2.1093), ANSI/IEEE C95.1-1992 and
IEEE Std 1528-2013

Product Name : Tablet

Trademark : ALLDOCUBE

Model Name : T1011

Family Model : U1006、U1008、U1010、U1101、U1102、
U1103、T701、T802、T1015、T1016、T1017、
T1018、T1019、T1020、T1021、T1022、T1023

Report No. : STR200703001007E

FCC ID : 2AKO6-T1011

Prepared for

Shenzhen Alldocube Technology and Science Co., Ltd
18/F, Jia'anda Bldg, Huafan Road, Dalang, Longhua District,
Shenzhen, China

Prepared by

Shenzhen NTEK Testing Technology Co., Ltd.
1/F, Building E, Fenda Science Park Sanwei, Xixiang, Bao'an District,
Shenzhen, Guangdong, China
Tel.: +86-755-6115 6588 Fax.: +86-755-6115 6599
Website: <http://www.ntek.org.cn>

TEST RESULT CERTIFICATION

Applicant's name.....: Shenzhen Alldocube Technology and Science Co., Ltd
Address.....: 18/F, Jia'anda Bldg, Huafan Road, Dalang, Longhua District, Shenzhen, China
Manufacturer's Name.....: Shenzhen Alldocube Technology and Science Co., Ltd
Address.....: 18/F, Jia'anda Bldg, Huafan Road, Dalang, Longhua District, Shenzhen, China

Product description

Product name.....: Tablet
Trademark: ALLDOCUBE
Model Name: T1011
U1006、U1008、U1010、U1101、U1102、U1103、T701、T802、
Family Model.....: T1015、T1016、T1017、T1018、T1019、T1020、T1021、T1022、T1023
FCC 47 CFR Part 2(2.1093)
Standards.....: ANSI/IEEE C95.1-1992
IEEE Std 1528-2013
Published RF exposure KDB procedures

This device described above has been tested by Shenzhen NTEK. In accordance with the measurement methods and procedures specified in IEEE Std 1528-2013 and KDB 865664 D01. Testing has shown that this device is capable of compliance with localized specific absorption rate (SAR) specified in FCC 47 CFR Part 2(2.1093) and ANSI/IEEE C95.1-1992. The test results in this report apply only to the tested sample of the stated device/equipment. Other similar device/equipment will not necessarily produce the same results due to production tolerance and measurement uncertainties.

This report shall not be reproduced except in full, without the written approval of Shenzhen NTEK, this document may be altered or revised by Shenzhen NTEK, personal only, and shall be noted in the revision of the document.

Date of Test

Date (s) of performance of tests.....: Jul. 15, 2020 ~ Jul. 18, 2020
Date of Issue: Jul. 21, 2020
Test Result: **Pass**

Prepared By
(Test Engineer)

: Cheng Jiawen
(Cheng Jiawen)

Approved By
(Lab Manager)

: Sam Chen
(Sam Chen)

※ ※ Revision History ※ ※

REV.	DESCRIPTION	ISSUED DATE	REMARK
Rev.1.0	Initial Test Report Release	Jul. 21, 2020	Cheng Jiawen

TABLE OF CONTENTS

1.	General Information	7
1.1.	RF exposure limits.....	7
1.2.	Statement of Compliance	8
1.3.	EUT Description	8
1.4.	Test specification(s)	10
1.5.	Ambient Condition.....	10
2.	SAR Measurement System	11
2.1.	SATIMO SAR Measurement Set-up Diagram	11
2.2.	Robot	12
2.3.	E-Field Probe.....	13
2.3.1.	E-Field Probe Calibration	13
2.4.	SAM phantoms	14
2.4.1.	Technical Data	15
2.5.	Device Holder	16
2.6.	Test Equipment List	17
3.	SAR Measurement Procedures	19
3.1.	Power Reference	19
3.2.	Area scan & Zoom scan.....	19
3.3.	Description of interpolation/extrapolation scheme	21
3.4.	Volumetric Scan	21
3.5.	Power Drift	21
4.	System Verification Procedure	22
4.1.	Tissue Verification	22
4.1.1.	Tissue Dielectric Parameter Check Results	23
4.2.	System Verification Procedure	24
4.2.1.	System Verification Results	25
5.	SAR Measurement variability and uncertainty	26
5.1.	SAR measurement variability	26
5.2.	SAR measurement uncertainty	26
6.	RF Exposure Positions.....	27
6.1.	Tablet host platform exposure conditions.....	27
7.	RF Output Power	28
7.1.	GSM Conducted Power	28
7.2.	WCDMA Conducted Power	28
7.3.	LTE Conducted Power	29
7.4.	WLAN & Bluetooth Output Power	36
7.4.1.	Output Power Results Of WLAN	36
7.4.2.	Output Power Results Of Bluetooth.....	36
8.	Antenna Location.....	37

9. Stand-alone SAR test exclusion.....	43
10. SAR Results	44
10.1. SAR measurement results	44
10.1.1. SAR measurement Result of GSM850	44
10.1.2. SAR measurement Result of GSM1900	44
10.1.3. SAR measurement Result of WCDMA Band 2	44
10.1.4. SAR measurement Result of WCDMA Band 5	45
10.1.5. SAR measurement Result of LTE Band 2	45
10.1.6. SAR measurement Result of LTE Band 5	46
10.1.7. SAR measurement Result of LTE Band 7	46
10.1.8. SAR measurement Result of WLAN 2.4G	47
10.2. SAR Summation Scenario.....	47
11. Appendix A. Photo documentation	51
12. Appendix B. System Check Plots.....	51
13. Appendix C. Plots of High SAR Measurement.....	60
14. Appendix D. Calibration Certificate	77

1. General Information

1.1. RF exposure limits

(A).Limits for Occupational/Controlled Exposure (W/kg)

Whole-Body	Partial-Body	Hands, Wrists, Feet and Ankles
0.4	8.0	20.0

(B).Limits for General Population/Uncontrolled Exposure (W/kg)

Whole-Body	Partial-Body	Hands, Wrists, Feet and Ankles
0.08	1.6	4.0

NOTE: **Whole-Body SAR** is averaged over the entire body, **partial-body SAR** is averaged over any 1 gram of tissue defined as a tissue volume in the shape of a cube. **SAR for hands, wrists, feet and ankles** is averaged over any 10 grams of tissue defined as a tissue volume in the shape of a cube.

Occupational/Controlled Environments:

Are defined as locations where there is exposure that may be incurred by people who are aware of the potential for exposure, (i.e. as a result of employment or occupation).

General Population/Uncontrolled Environments:

Are defined as locations where there is the exposure of individuals who have no knowledge or control of their exposure.

NOTE
 TRUNK LIMIT
 1.6 W/kg
 APPLIED TO THIS EUT

1.2. Statement of Compliance

The maximum results of Specific Absorption Rate (SAR) found during testing for T1011 are as follows.

RF Exposure Conditions		Equipment Class - Highest Reported SAR (W/kg)			
		PCB	DTS	NII	DSS
1-g Body (Separation distance of 0mm)		1.215	0.350	N/A	N/A
Max Simultaneous Tx	Body	1.565	1.565	N/A	1.226

Note: The Max Simultaneous Tx is calculated based on the same configuration and test position. This device is in compliance with Specific Absorption Rate (SAR) for general population/uncontrolled exposure limits (1.6 W/kg) specified in FCC 47 CFR Part 2(2.1093) and ANSI/IEEE C95.1-1992, and had been tested in accordance with the measurement methods and procedures specified in IEEE Std 1528-2013 & KDB 865664 D01.

1.3. EUT Description

Device Information			
Product Name	Tablet		
Trade Name	ALLDOCUBE		
Model Name	T1011		
Family Model	U1006、U1008、U1010、U1101、U1102、U1103、T701、T802、T1015、T1016、T1017、T1018、T1019、T1020、T1021、T1022、T1023		
FCC ID	2AKO6-T1011		
Device Phase	Identical Prototype		
Exposure Category	General population / Uncontrolled environment		
Antenna	PIFA Antenna		
Battery Information	DC 3.8V, 6000mAh		
Device Operating Configurations			
Supporting Mode(s)	GSM 850/1900, WCDMA Band 2/5, LTE Band 2/5/7, WLAN 2.4G, Bluetooth		
Test Modulation	GSM(GMSK/8PSK), WCDMA(QPSK), LTE(QPSK/16QAM), WLAN(DSSS/OFDM), Bluetooth(GFSK, π/4-DQPSK, 8DPSK)		
Device Class	B		
Operating Frequency Range(s)	Band	Tx (MHz)	Rx (MHz)
	GSM 850	824-849	869-894
	GSM 1900	1850-1910	1930-1990
	WCDMA Band 2	1850-1910	1930-1990
	WCDMA Band 5	824-849	869-894
	LTE Band 2	1850-1910	1930-1990

	LTE Band 5	824-849	869-894
	LTE Band 7	2500-2570	2620-2690
	WLAN 2.4G	2412-2462	
	Bluetooth	2402-2480	
GPRS Multislot Class(12)	Max Number of Timeslots in Uplink	4	
	Max Number of Timeslots in Downlink	4	
	Max Total Timeslot	5	
EDGE Multislot Class(12)	Max Number of Timeslots in Uplink	4	
	Max Number of Timeslots in Downlink	4	
	Max Total Timeslot	5	
Power Class	4, tested with power level 5(GSM 850)		
	1, tested with power level 0(GSM 1900)		
	3, tested with power control "all 1"(WCDMA Band 2)		
	3, tested with power control "all 1"(WCDMA Band 5)		
	3, tested with power control all Max.(LTE Band 2)		
	3, tested with power control all Max.(LTE Band 5)		
	3, tested with power control all Max.(LTE Band 7)		
Test Channels (low-mid-high)	128-189-251(GSM 850)		
	512-661-810(GSM 1900)		
	9262-9400-9538(WCDMA Band 2)		
	4132-4182-4233(WCDMA Band 5)		
	18607-18900-19193(LTE Band 2 BW=1.4MHz)		
	18615-18900-19185(LTE Band 2 BW=3MHz)		
	18625-18900-19175(LTE Band 2 BW=5MHz)		
	18650-18900-19150(LTE Band 2 BW=10MHz)		
	18675-18900-19125(LTE Band 2 BW=15MHz)		
	18700-18900-19100(LTE Band 2 BW=20MHz)		
	20407-20525-20643(LTE Band 5 BW=1.4MHz)		
	20415-20525-20635(LTE Band 5 BW=3MHz)		
	20425-20525-20625(LTE Band 5 BW=5MHz)		
	20450-20525-20600(LTE Band 5 BW=10MHz)		
	20775-21100-21425(LTE Band 7 BW=5MHz)		
	20800-21100-21400(LTE Band 7 BW=10MHz)		
	20825-21100-21375(LTE Band 7 BW=15MHz)		
20850-21100-21350(LTE Band 7 BW=20MHz)			
1-3-6-9-11(WLAN 2.4G)			

1.4. Test specification(s)

FCC 47 CFR Part 2(2.1093)
ANSI/IEEE C95.1-1992
IEEE Std 1528-2013
KDB 865664 D01 SAR measurement 100 MHz to 6 GHz
KDB 865664 D02 RF Exposure Reporting
KDB 447498 D01 General RF Exposure Guidance
KDB 248227 D01 802.11 Wi-Fi SAR
KDB 941225 D01 3G SAR Procedures
KDB 941225 D05 SAR for LTE Devices
KDB 616217 D04 SAR for laptop and tablets

1.5. Ambient Condition

Ambient temperature	20°C – 24°C
Relative Humidity	30% – 70%

2. SAR Measurement System

2.1. SATIMO SAR Measurement Set-up Diagram

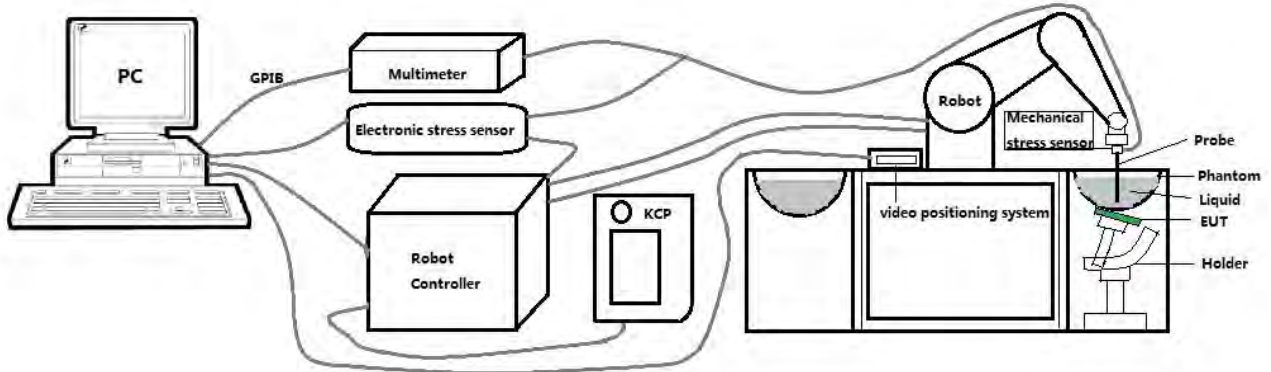

These measurements were performed with the automated near-field scanning system OPENSAR from SATIMO. The system is based on a high precision robot (working range: 901 mm), which positions the probes with a positional repeatability of better than ± 0.03 mm. The SAR measurements were conducted with dosimetric probe (manufactured by SATIMO), designed in the classical triangular configuration and optimized for dosimetric evaluation.

The first step of the field measurement is the evaluation of the voltages induced on the probe by the device under test. Probe diode detectors are nonlinear. Below the diode compression point, the output voltage is proportional to the square of the applied E-field; above the diode compression point, it is linear to the applied E-field. The compression point depends on the diode, and a calibration procedure is necessary for each sensor of the probe.

The Keithley multimeter reads the voltage of each sensor and send these three values to the PC. The corresponding E field value is calculated using the probe calibration factors, which are stored in the working directory. This evaluation includes linearization of the diode characteristics. The field calculation is done separately for each sensor. Each component of the E field is displayed on the "Dipole Area Scan Interface" and the total E field is displayed on the "3D Interface"

2.2. Robot

The SATIMO SAR system uses the high precision robots from KUKA. For the 6-axis controller system, the robot controller version (KUKA) from KUKA is used. The KUKA robot series have many features that are important for our application:



- High precision (repeatability ± 0.03 mm)
- High reliability (industrial design)
- Jerk-free straight movements
- Low ELF interference (the closed metallic construction shields against motor control fields)

2.3. E-Field Probe

This E-field detection probe is composed of three orthogonal dipoles linked to special Schottky diodes with low detection thresholds. The probe allows the measurement of electric fields in liquids such as the one defined in the IEEE and CENELEC standards.

For the measurements the Specific Dosimetric E-Field Probe SN 08/16 EPGO287 with following specifications is used



- Dynamic range: 0.01-100 W/kg
 - Tip Diameter: 2.5 mm
 - Distance between probe tip and sensor center: 1 mm
 - Distance between sensor center and the inner phantom surface: 2 mm (repeatability better than ± 1 mm).
 - Probe linearity: ± 0.08 dB
 - Axial isotropy: 0.06 dB
 - Hemispherical Isotropy: 0.08 dB
 - Calibration range: 650MHz to 5900MHz for head & body simulating liquid.
 - Lower detection limit: 7mW/kg
- Angle between probe axis (evaluation axis) and surface normal line: less than 30° .

2.3.1. E-Field Probe Calibration

Each probe needs to be calibrated according to a dosimetric assessment procedure with accuracy better than $\pm 10\%$. The spherical isotropy shall be evaluated and within ± 0.25 dB. The sensitivity parameters (Norm X, Norm Y, and Norm Z), the diode compression parameter (DCP) and the conversion factor (Conv F) of the probe are tested. The calibration data can be referred to appendix D of this report.

2.4. SAM phantoms

Photo of SAM phantom SN 16/15 SAM119



The SAM phantom is used to measure the SAR relative to people exposed to electro-magnetic field radiated by mobile phones.

2.4.1. Technical Data

Serial Number	Shell thickness	Filling volume	Dimensions	Positionner Material	Permittivity	Loss Tangent
SN 16/15 SAM119	2 mm ±0.2 mm	27 liters	Length:1000 mm Width:500 mm Height:200 mm	Gelcoat with fiberglass	3.4	0.02

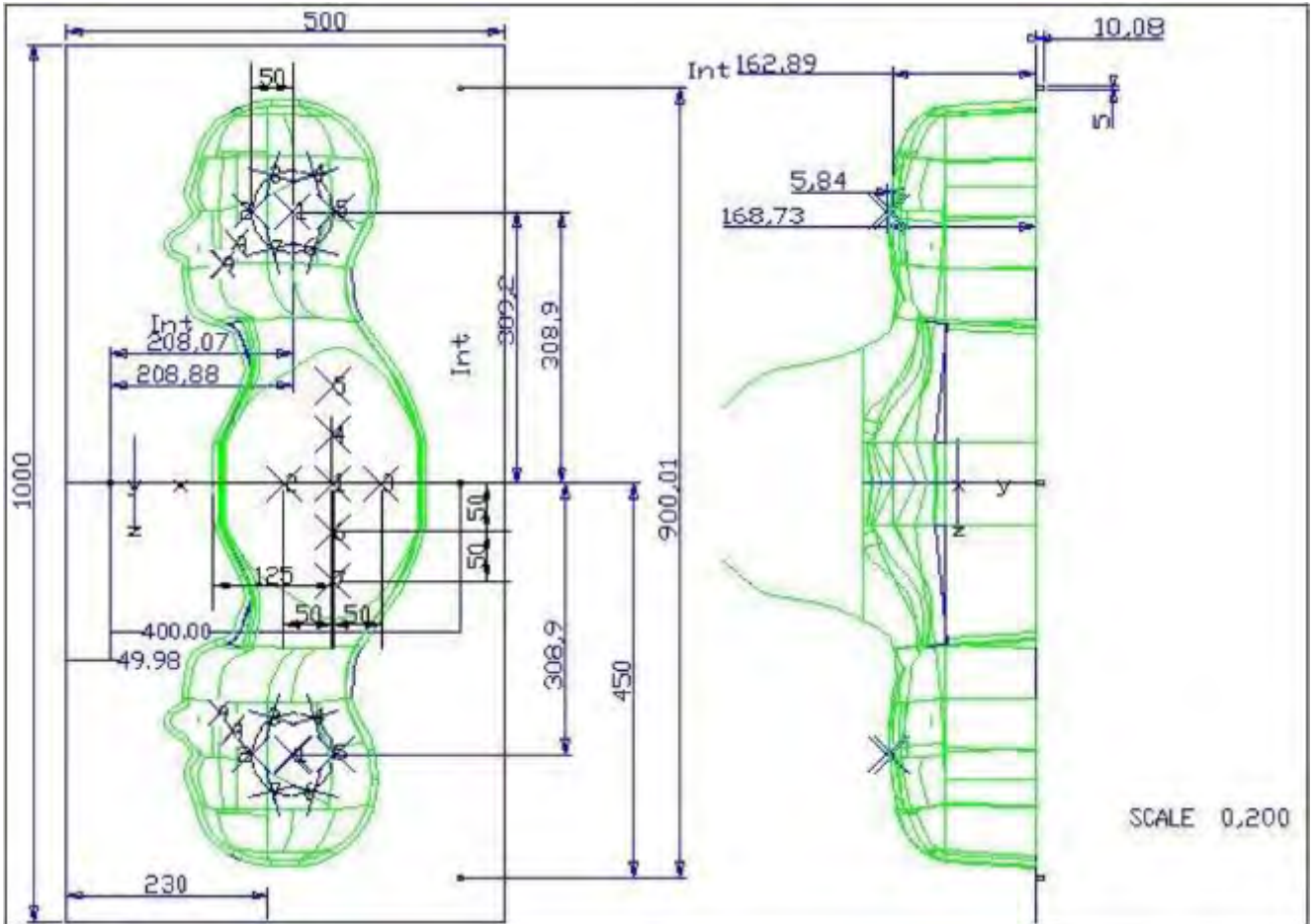

Serial Number	Left Head(mm)		Right Head(mm)		Flat Part(mm)	
	1	2	1	2	1	2
SN 16/15 SAM119	2	2.02	2	2.08	1	2.09
	3	2.05	3	2.06	2	2.06
	4	2.07	4	2.07	3	2.08
	5	2.08	5	2.08	4	2.10
	6	2.05	6	2.07	5	2.10
	7	2.05	7	2.05	6	2.07
	8	2.07	8	2.06	7	2.07
	9	2.08	9	2.06	-	-

The test, based on ultrasonic system, allows measuring the thickness with an accuracy of 10 µm.

2.5. Device Holder

The positioning system allows obtaining cheek and tilting position with a very good accuracy. In compliance with CENELEC, the tilt angle uncertainty is lower than 1 degree.

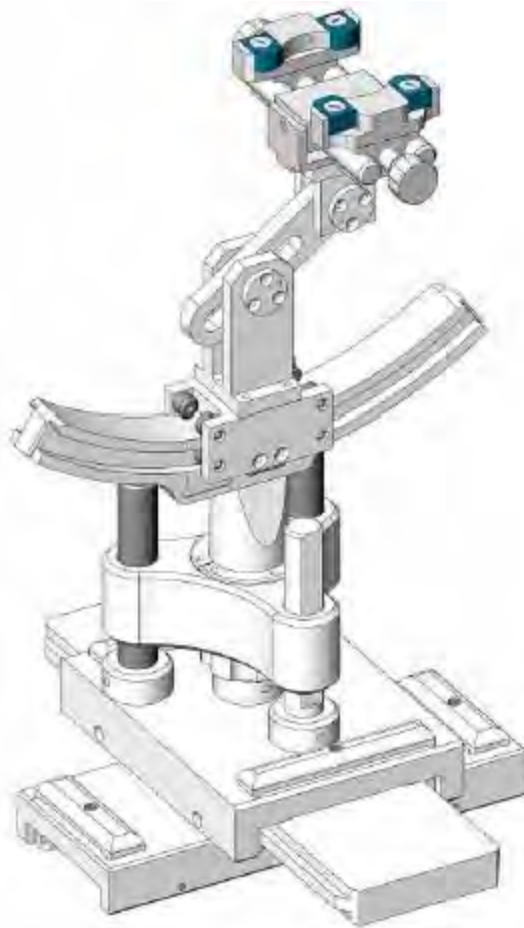

Serial Number	Holder Material	Permittivity	Loss Tangent
SN 16/15 MSH100	Delrin	3.7	0.005

2.6. Test Equipment List

This table gives a complete overview of the SAR measurement equipment.

Devices used during the test described are marked

	Manufacturer	Name of Equipment	Type/Model	Serial Number	Calibration	
					Last Cal.	Due Date
<input checked="" type="checkbox"/>	MVG	E FIELD PROBE	SSE2	SN 08/16 EPGO287	Dec. 27, 2019	Dec. 26, 2020
<input type="checkbox"/>	MVG	750 MHz Dipole	SID750	SN 03/15 DIP 0G750-355	Apr. 19, 2018	Apr. 18, 2021
<input checked="" type="checkbox"/>	MVG	835 MHz Dipole	SID835	SN 03/15 DIP 0G835-347	Apr. 19, 2018	Apr. 18, 2021
<input type="checkbox"/>	MVG	900 MHz Dipole	SID900	SN 03/15 DIP 0G900-348	Apr. 19, 2018	Apr. 18, 2021
<input type="checkbox"/>	MVG	1800 MHz Dipole	SID1800	SN 03/15 DIP 1G800-349	Apr. 19, 2018	Apr. 18, 2021
<input checked="" type="checkbox"/>	MVG	1900 MHz Dipole	SID1900	SN 03/15 DIP 1G900-350	Apr. 19, 2018	Apr. 18, 2021
<input type="checkbox"/>	MVG	2000 MHz Dipole	SID2000	SN 03/15 DIP 2G000-351	Apr. 19, 2018	Apr. 18, 2021
<input checked="" type="checkbox"/>	MVG	2450 MHz Dipole	SID2450	SN 03/15 DIP 2G450-352	Apr. 19, 2018	Apr. 18, 2021
<input checked="" type="checkbox"/>	MVG	2600 MHz Dipole	SID2600	SN 03/15 DIP 2G600-356	Apr. 19, 2018	Apr. 18, 2021
<input type="checkbox"/>	MVG	5000 MHz Dipole	SWG5500	SN 13/14 WGA 33	Apr. 19, 2018	Apr. 18, 2021
<input checked="" type="checkbox"/>	MVG	Liquid measurement Kit	SCLMP	SN 21/15 OCPG 72	NCR	NCR
<input checked="" type="checkbox"/>	MVG	Power Amplifier	N.A	AMPLISAR_28/14_003	NCR	NCR
<input checked="" type="checkbox"/>	KEITHLEY	Millivoltmeter	2000	4072790	NCR	NCR
<input checked="" type="checkbox"/>	R&S	Universal radio communication tester	CMU200	117858	Aug. 06, 2019	Aug. 05, 2020
<input checked="" type="checkbox"/>	R&S	Wideband radio communication tester	CMW500	103917	Aug. 28, 2019	Aug. 27, 2020
<input checked="" type="checkbox"/>	HP	Network Analyzer	8753D	3410J01136	Aug. 06, 2019	Aug. 05, 2020
<input checked="" type="checkbox"/>	Agilent	PSG Analog Signal Generator	E8257D	MY51110112	Aug. 06, 2019	Aug. 05, 2020

<input checked="" type="checkbox"/>	Agilent	Power meter	E4419B	MY45102538	Aug. 06, 2019	Aug. 05, 2020
<input checked="" type="checkbox"/>	Agilent	Power sensor	E9301A	MY41495644	Aug. 06, 2019	Aug. 05, 2020
<input checked="" type="checkbox"/>	Agilent	Power sensor	E9301A	US39212148	Aug. 06, 2019	Aug. 05, 2020
<input checked="" type="checkbox"/>	MCLI/USA	Directional Coupler	CB11-20	0D2L51502	Aug. 06, 2019	Aug. 05, 2020

3. SAR Measurement Procedures

The measurement procedures are as follows:

<Conducted power measurement>

- (a) For WWAN power measurement, use base station simulator to configure EUT WWAN transmission in conducted connection with RF cable, at maximum power in each supported wireless interface and frequency band.
- (b) Read the WWAN RF power level from the base station simulator.
- (c) For WLAN/Bluetooth power measurement, use engineering software to configure EUT WLAN/Bluetooth continuously transmission, at maximum RF power in each supported wireless interface and frequency band.
- (d) Connect EUT RF port through RF cable to the power meter, and measure WLAN/Bluetooth output power.

<SAR measurement>

- (a) Use base station simulator to configure EUT WWAN transmission in radiated connection, and engineering software to configure EUT WLAN/Bluetooth continuously transmission, at maximum RF power, in the highest power channel.
- (b) Place the EUT in the positions as Appendix A demonstrates.
- (c) Set scan area, grid size and other setting on the OPENSAR software.
- (d) Measure SAR results for the highest power channel on each testing position.
- (e) Find out the largest SAR result on these testing positions of each band.
- (f) Measure SAR results for other channels in worst SAR testing position if the reported SAR of highest power channel is larger than 0.8 W/kg.

According to the test standard, the recommended procedure for assessing the peak spatial-average SAR value consists of the following steps:

- (a) Power reference measurement
- (b) Area scan
- (c) Zoom scan
- (d) Power drift measurement

3.1. Power Reference

The Power Reference Measurement and Power Drift Measurements are for monitoring the power drift of the device under test in the batch process. The minimum distance of probe sensors to surface determines the closest measurement point to phantom surface. This distance cannot be smaller than the distance of sensor calibration points to probe tip as defined in the probe properties.

3.2. Area scan & Zoom scan

The area scan is a 2D scan to find the hot spot location on the DUT. The zoom scan is a 3D scan above the hot spot to calculate the 1g and 10g SAR value.

Measurement of the SAR distribution with a grid of 8 to 16 mm * 8 to 16 mm and a constant distance to the inner surface of the phantom. Since the sensors cannot directly measure at the inner phantom surface, the values between the sensors and the inner phantom surface are extrapolated. With these values the area of the maximum SAR is calculated by an interpolation scheme. Around this point, a cube of 30 * 30 * 30 mm or 32 * 32 * 32 mm is assessed by measuring 5 or 8 * 5 or 8 * 4 or 5 mm. With these data, the peak spatial-average SAR value can be calculated.

From the scanned SAR distribution, identify the position of the maximum SAR value, in addition identify the positions of any local maxima with SAR values within 2 dB of the maximum value that will not be within the zoom scan of other peaks; additional peaks shall be measured only when the primary peak is within 2 dB of the SAR compliance limit (e.g., 1 W/kg for 1,6 W/kg 1 g limit, or 1,26 W/kg for 2 W/kg, 10 g limit).

Area scan & Zoom scan scan parameters extracted from FCC KDB 865664 D01 SAR measurement 100 MHz to 6 GHz.

		≤ 3 GHz	> 3 GHz
Maximum distance from closest measurement point (geometric center of probe sensors) to phantom surface		5 ± 1 mm	½ · δ · ln(2) ± 0.5 mm
Maximum probe angle from probe axis to phantom surface normal at the measurement location		30° ± 1°	20° ± 1°
Maximum area scan spatial resolution: Δx _{Area} , Δy _{Area}		≤ 2 GHz: ≤ 15 mm 2 – 3 GHz: ≤ 12 mm	3 – 4 GHz: ≤ 12 mm 4 – 6 GHz: ≤ 10 mm
		When the x or y dimension of the test device, in the measurement plane orientation, is smaller than the above, the measurement resolution must be ≤ the corresponding x or y dimension of the test device with at least one measurement point on the test device.	
Maximum zoom scan spatial resolution: Δx _{Zoom} , Δy _{Zoom}		≤ 2 GHz: ≤ 8 mm 2 – 3 GHz: ≤ 5 mm*	3 – 4 GHz: ≤ 5 mm* 4 – 6 GHz: ≤ 4 mm*
Maximum zoom scan spatial resolution, normal to phantom surface	uniform grid: Δz _{Zoom} (n)	≤ 5 mm	3 – 4 GHz: ≤ 4 mm 4 – 5 GHz: ≤ 3 mm 5 – 6 GHz: ≤ 2 mm
	graded grid	Δz _{Zoom} (1): between 1 st two points closest to phantom surface	≤ 4 mm 3 – 4 GHz: ≤ 3 mm 4 – 5 GHz: ≤ 2.5 mm 5 – 6 GHz: ≤ 2 mm
		Δz _{Zoom} (n>1): between subsequent points	≤ 1.5 · Δz _{Zoom} (n-1)
Minimum zoom scan volume	x, y, z	≥ 30 mm	3 – 4 GHz: ≥ 28 mm 4 – 5 GHz: ≥ 25 mm 5 – 6 GHz: ≥ 22 mm

Note: δ is the penetration depth of a plane-wave at normal incidence to the tissue medium; see draft standard IEEE P1528-2011 for details.

* When zoom scan is required and the *reported* SAR from the *area scan based 1-g SAR estimation* procedures of KDB 447498 is ≤ 1.4 W/kg, ≤ 8 mm, ≤ 7 mm and ≤ 5 mm zoom scan resolution may be applied, respectively, for 2 GHz to 3 GHz, 3 GHz to 4 GHz and 4 GHz to 6 GHz.

3.3. Description of interpolation/extrapolation scheme

The local SAR inside the phantom is measured using small dipole sensing elements inside a probe body. The probe tip must not be in contact with the phantom surface in order to minimise measurements errors, but the highest local SAR will occur at the surface of the phantom.

An extrapolation is using to determinate this highest local SAR values. The extrapolation is based on a fourth-order least-square polynomial fit of measured data. The local SAR value is then extrapolated from the liquid surface with a 1 mm step.

The measurements have to be performed over a limited time (due to the duration of the battery) so the step of measurement is high. It could vary between 5 and 8 mm. To obtain an accurate assessment of the maximum SAR averaged over 10 grams and 1 gram requires a very fine resolution in the three dimensional scanned data array.

3.4. Volumetric Scan

The volumetric scan consists to a full 3D scan over a specific area. This 3D scan is useful form multi Tx SAR measurement. Indeed, it is possible with OpenSAR to add, point by point, several volumetric scan to calculate the SAR value of the combined measurement as it is define in the standard IEEE1528 and IEC62209.

3.5. Power Drift

All SAR testing is under the EUT install full charged battery and transmit maximum output power. In OpenSAR measurement software, the power reference measurement and power drift measurement procedures are used for monitoring the power drift of EUT during SAR test. Both these procedures measure the field at a specified reference position before and after the SAR testing. The software will calculate the field difference in V/m. If the power drifts more than $\pm 5\%$, the SAR will be retested.

4. System Verification Procedure

4.1. Tissue Verification

The following tissue formulations are provided for reference only as some of the parameters have not been thoroughly verified. The composition of ingredients may be modified accordingly to achieve the desired target tissue parameters required for routine SAR evaluation.

Ingredients (% of weight)	Head Tissue									
	750	835	900	1800	1900	2000	2450	2600	5200	5800
Frequency Band (MHz)										
Water	34.40	34.40	34.40	55.36	55.36	57.87	57.87	57.87	65.53	65.53
NaCl	0.79	0.79	0.79	0.35	0.35	0.16	0.16	0.16	0.00	0.00
1,2-Propanediol	64.81	64.81	64.81	0.00	0.00	0.00	0.00	0.00	0.00	0.00
Triton X-100	0.00	0.00	0.00	30.45	30.45	19.97	19.97	19.97	24.24	24.24
DGBE	0.00	0.00	0.00	13.84	13.84	22.00	22.00	22.00	10.23	10.23
Ingredients (% of weight)	Body Tissue									
	750	835	900	1800	1900	2000	2450	2600	5200	5800
Frequency Band (MHz)										
Water	50.30	50.30	50.30	69.91	69.91	71.88	71.88	71.88	79.54	79.54
NaCl	0.60	0.60	0.60	0.13	0.13	0.16	0.16	0.16	0.00	0.00
1,2-Propanediol	49.10	49.10	49.10	0.00	0.00	0.00	0.00	0.00	0.00	0.00
Triton X-100	0.00	0.00	0.00	9.99	9.99	19.97	19.97	19.97	11.24	11.24
DGBE	0.00	0.00	0.00	19.97	19.97	7.99	7.99	7.99	9.22	9.22

For SAR measurement of the field distribution inside the phantom, the phantom must be filled with homogeneous tissue simulating liquid to a depth of at least 15 cm. For head SAR testing, the liquid depth from the ear reference point (ERP) of the phantom to the liquid top surface is larger than 15 cm.

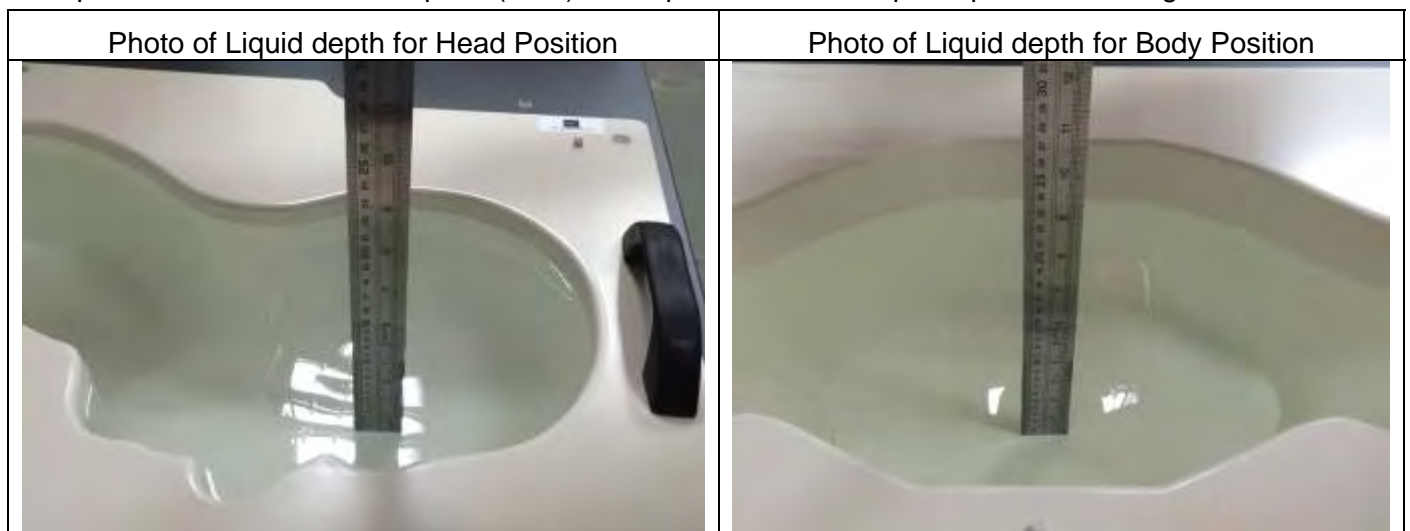

4.1.1. Tissue Dielectric Parameter Check Results

The simulating liquids should be checked at the beginning of a series of SAR measurements to determine if the dielectric parameters are within the tolerances of the specified target values. The measured conductivity and relative permittivity should be within $\pm 5\%$ of the target values.

Tissue Type	Measured Frequency (MHz)	Target Tissue		Measured Tissue		Liquid Temp.	Test Date
		$\epsilon_r (\pm 5\%)$	σ (S/m) ($\pm 5\%$)	ϵ_r	σ (S/m)		
Body 850	835	55.20 (52.44~57.96)	0.97 (0.92~1.02)	54.49	0.98	21.5 °C	Jul. 15, 2020
Body 1900	1900	53.30 (50.64~55.97)	1.52 (1.44~1.60)	54.23	1.53	21.5 °C	Jul. 16, 2020
Body 2450	2450	52.70 (50.07~55.34)	1.95 (1.85~2.05)	51.49	1.89	21.5 °C	Jul. 17, 2020
Body 2600	2600	52.51 (49.88~55.14)	2.16 (2.05~2.27)	52.82	2.22	21.2 °C	Jul. 18, 2020

NOTE: The dielectric parameters of the tissue-equivalent liquid should be measured under similar ambient conditions and within 2 °C of the conditions expected during the SAR evaluation to satisfy protocol requirements.

4.2. System Verification Procedure

The system verification is performed for verifying the accuracy of the complete measurement system and performance of the software. The dipole is connected to the signal source consisting of signal generator and amplifier via a directional coupler, N-connector cable and adaption to SMA. It is fed with a power of 100mW (below 5GHz) or 100mW (above 5GHz). To adjust this power a power meter is used. The power sensor is connected to the cable before the system verification to measure the power at this point and do adjustments at the signal generator. At the outputs of the directional coupler both return loss as well as forward power are controlled during the system verification to make sure that emitted power at the dipole is kept constant. This can also be checked by the power drift measurement after the test (result on plot).

The system verification is shown as below picture:

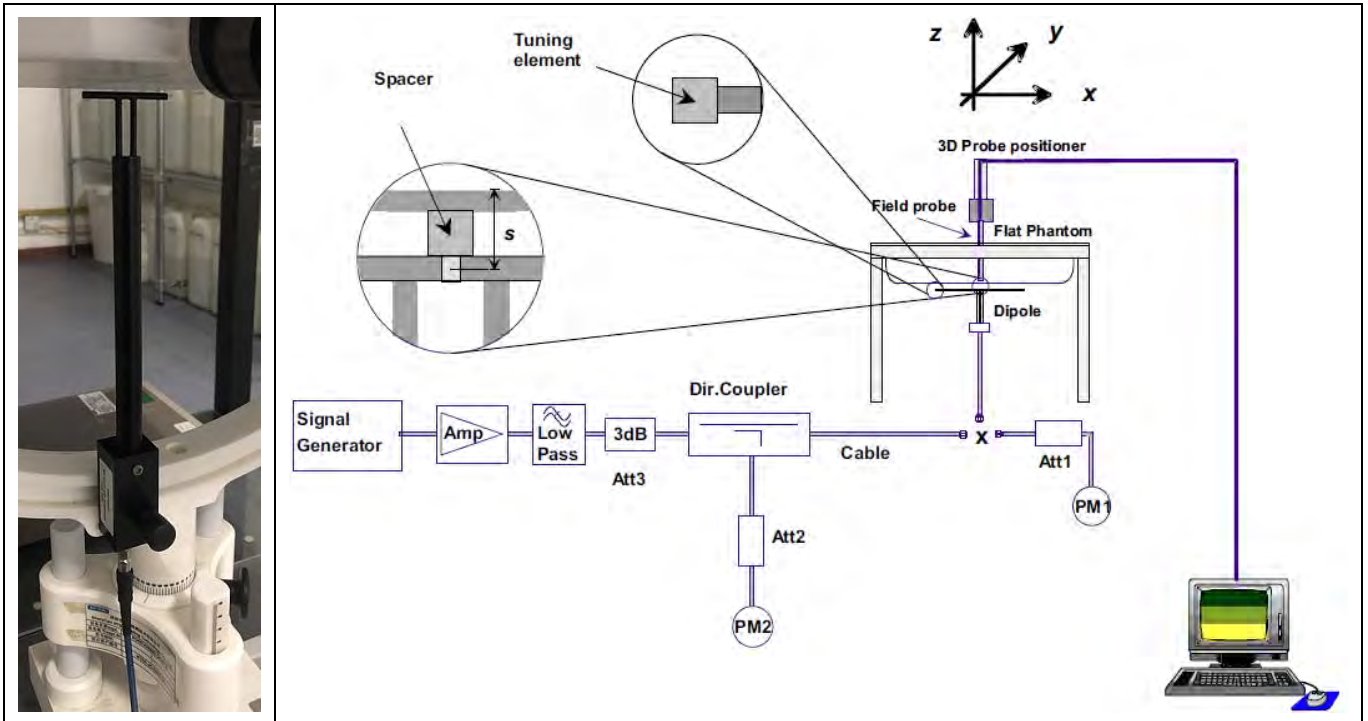

4.2.1. System Verification Results

Comparing to the original SAR value provided by SATIMO, the verification data should be within its specification of $\pm 10\%$. Below table shows the target SAR and measured SAR after normalized to 1W input power. The table below indicates the system performance verification can meet the variation criterion and the plots can be referred to Appendix B of this report.

System Verification	Target SAR (1W) ($\pm 10\%$)		Measured SAR (Normalized to 1W)		Liquid Temp.	Test Date
	1-g (W/Kg)	10-g (W/Kg)	1-g (W/Kg)	10-g (W/Kg)		
835MHz Body	9.83 (8.85~10.81)	6.45 (5.81~7.10)	9.79	6.15	21.5 °C	Jul. 15, 2020
1900MHz Body	39.02 (35.12~42.92)	20.57 (18.51~22.63)	39.55	20.17	21.5 °C	Jul. 16, 2020
2450MHz Body	52.90 (47.61~58.19)	24.09 (21.68~26.50)	53.36	23.21	21.5 °C	Jul. 17, 2020
2600MHz Body	52.49 (47.24~57.74)	23.74 (21.37~26.11)	50.13	23.59	21.2 °C	Jul. 18, 2020

5. SAR Measurement variability and uncertainty

5.1. SAR measurement variability

Per KDB865664 D01 SAR measurement 100 MHz to 6 GHz, SAR measurement variability must be assessed for each frequency band, which is determined by the SAR probe calibration point and tissue-equivalent medium used for the device measurements. The additional measurements are repeated after the completion of all measurements requiring the same head or body tissue-equivalent medium in a frequency band. The test device should be returned to ambient conditions (normal room temperature) with the battery fully charged before it is re-mounted on the device holder for the repeated measurement(s) to minimize any unexpected variations in the repeated results.

- 1) Repeated measurement is not required when the original highest measured SAR is < 0.80 W/kg; steps 2) through 4) do not apply.
- 2) When the original highest measured SAR is ≥ 0.80 W/kg, repeat that measurement once.
- 3) Perform a second repeated measurement only if the ratio of largest to smallest SAR for the original and first repeated measurements is > 1.20 or when the original or repeated measurement is ≥ 1.45 W/kg (~ 10% from the 1-g SAR limit).
- 4) Perform a third repeated measurement only if the original, first or second repeated measurement is ≥ 1.5 W/kg and the ratio of largest to smallest SAR for the original, first and second repeated measurements is > 1.20 .

5.2. SAR measurement uncertainty

Per KDB865664 D01 SAR Measurement 100 MHz to 6 GHz, when the highest measured 1-g SAR within a frequency band is < 1.5 W/kg, the extensive SAR measurement uncertainty analysis described in IEEE Std 1528-2013 is not required in SAR reports submitted for equipment approval. The equivalent ratio (1.5/1.6) is applied to extremity and occupational exposure conditions.

6. RF Exposure Positions

6.1. Tablet host platform exposure conditions

Refer to KDB616217 D04, when the modular approach is used, transmitters and modules must be initially tested for standalone operations in generic host conditions according to the following minimum test separation distance and antenna installation requirements for incorporation in the tablet platform. The separation distance required for incorporation in qualified hosts is described in KDB 447498; item 5) of section 4.1 and item 1) of section 5.2.2 etc.

- ≤ 5 mm between the antenna and user for both back surface and edge exposure conditions
- the antennas used by the host must have been tested for equipment approval or qualify for SAR test exclusion
- the antenna polarization, physical orientation, rotation and installation configurations used by the host must have been tested for compliance or qualify for test exclusion
- when the *SAR Test Exclusion Threshold* in KDB 447498 applies, a *test separation distance of 5 mm* is required to determine test exclusion for the tablet platform

The antennas embedded in tablets are typically ≤ 5 mm from the outer housing. The required antenna to user test separation distance is a “not to exceed test” distance required to apply the modular approach. Instead of the typical zero gap tablet edge test requirement between the edge of a tablet and the user, when an antenna has been tested at ≤ 5 mm according to the modular approach it can be incorporated into tablets with at least twice the tested distance from the outer housing of the tablet edge; otherwise, the tablet edge zero gap test requirement applies. When the dedicated host approach is applied, the back surface and edges of the tablet should be tested for SAR compliance with the tablet touching the phantom.

7. RF Output Power

7.1. GSM Conducted Power

Band GSM850		Burst-Averaged output Power (dBm)			Frame-Averaged output Power (dBm)			
Tx Channel	Tune-up (dBm)	128	189	251	Tune-up (dBm)	128	189	251
Frequency (MHz)		824.2	836.4	848.8		824.2	836.4	848.8
GSM (GMSK)	34.00	33.67	33.65	33.75	24.97	24.64	24.62	24.72
GPRS(GMSK, 1 TS)	34.00	33.64	33.64	33.76	24.97	24.61	24.61	24.73
GPRS(GMSK, 2 TS)	32.00	31.63	31.48	31.49	25.98	25.61	25.46	25.47
GPRS(GMSK, 3 TS)	30.00	29.81	29.63	29.64	25.74	25.55	25.37	25.38
GPRS(GMSK, 4 TS)	28.00	27.59	27.47	27.44	24.99	24.58	24.46	24.43
EDGE(GMSK, 1 TS)	27.00	26.05	26.72	26.88	17.97	17.02	17.69	17.85
EDGE(GMSK, 2 TS)	26.00	25.02	25.67	24.91	19.98	19.00	19.65	18.89
EDGE(GMSK, 3 TS)	23.00	21.92	22.95	21.93	18.74	17.66	18.69	17.67
EDGE(GMSK, 4 TS)	20.00	18.07	19.43	18.16	16.99	15.06	16.42	15.15
Band GSM1900		Burst-Averaged output Power (dBm)			Frame-Averaged output Power (dBm)			
Tx Channel	Tune-up (dBm)	512	661	810	Tune-up (dBm)	512	661	810
Frequency (MHz)		1850.2	1880.0	1909.8		1850.2	1880.0	1909.8
GSM (GMSK)	31.00	30.51	30.67	30.65	21.97	21.48	21.64	21.62
GPRS(GMSK, 1 TS)	31.00	30.54	30.71	30.69	21.97	21.51	21.68	21.66
GPRS(GMSK, 2 TS)	28.50	28.25	28.31	28.27	22.48	22.23	22.29	22.25
GPRS(GMSK, 3 TS)	27.00	26.72	26.78	26.74	22.74	22.46	22.52	22.48
GPRS(GMSK, 4 TS)	25.00	24.71	24.80	24.73	21.99	21.70	21.79	21.72
EDGE(GMSK, 1 TS)	28.00	26.95	27.37	26.78	18.97	17.92	18.34	17.75
EDGE(GMSK, 2 TS)	27.00	25.58	26.13	25.14	20.98	19.56	20.11	19.12
EDGE(GMSK, 3 TS)	24.00	22.74	23.53	22.37	19.74	18.48	19.27	18.11
EDGE(GMSK, 4 TS)	21.00	19.28	20.69	19.31	17.99	16.27	17.68	16.30

Note: The frame-averaged power is linearly scaled the maximum burst averaged power over 8 time slots.

The calculated method are shown as below:

Frame-averaged power = Maximum burst averaged power (1 TS) - 9.03 dB

Frame-averaged power = Maximum burst averaged power (2 TS) - 6.02 dB

Frame-averaged power = Maximum burst averaged power (3 TS) - 4.26 dB

Frame-averaged power = Maximum burst averaged power (4 TS) - 3.01 dB

7.2. WCDMA Conducted Power

Band		WCDMA Band 2		
Tx Channel	Tune-up	9262	9400	9538
Frequency (MHz)		1852.4	1880	1907.6
RMC12.2K	24.00	23.50	23.50	23.74
HSDPA Sub 1	24.00	23.34	23.19	23.31
HSDPA Sub 2	24.00	23.03	22.91	22.99
HSDPA Sub 3	23.00	22.74	22.47	22.48
HSDPA Sub 4	23.00	22.53	22.37	22.24
HSUPA Sub 1	24.00	23.16	23.08	23.00
HSUPA Sub 2	24.00	23.35	23.26	23.23
HSUPA Sub 3	23.00	22.81	22.83	22.83
HSUPA Sub 4	24.00	23.38	23.24	23.30
HSUPA Sub 5	24.00	23.10	22.98	22.81
Band		WCDMA Band 5		
Tx Channel	Tune-up	4132	4182	4233
Frequency (MHz)		826.4	836.4	846.6
RMC12.2K	24.00	23.41	23.38	23.48
HSDPA Sub 1	23.00	22.73	22.82	22.53
HSDPA Sub 2	23.00	22.49	22.62	22.29
HSDPA Sub 3	23.00	22.15	22.17	21.94
HSDPA Sub 4	23.00	22.09	22.18	21.85
HSUPA Sub 1	23.00	22.47	22.61	22.33
HSUPA Sub 2	23.00	22.67	22.84	22.52
HSUPA Sub 3	23.00	22.44	22.55	22.23
HSUPA Sub 4	23.00	22.71	22.86	22.57
HSUPA Sub 5	23.00	22.50	22.61	22.16

7.3. LTE Conducted Power

Band	Band Width	Modulation	RB Configuration		Tune-up	Channel/Frequency(MHz)		
			RB Size	RB Offset		18607/1850.7	18900/1880	19193/1909.3
LTE Band 2	1.4MHz	QPSK	1	0	25.00	24.00	24.14	24.32
			1	2	25.00	24.04	24.10	24.28
			1	5	25.00	24.06	24.05	24.26
			3	0	25.00	23.91	23.91	24.21
			3	1	25.00	24.20	24.97	24.23
			3	2	25.00	23.97	23.93	24.16

Band	Band Width	Modulation	RB Configuration		Tune-up	Channel/Frequency(MHz)		
			RB Size	RB Offset		18615/1851.5	18900/1880	19185/1908.5
		16QAM	6	0	24.00	22.77	23.01	23.17
			1	0	24.00	23.84	23.19	23.37
			1	2	24.00	23.84	23.17	23.47
			1	5	24.00	23.91	23.16	23.32
			3	0	24.00	23.12	23.10	23.55
			3	1	24.00	23.15	23.13	23.47
			3	2	24.00	23.15	23.10	23.46
			6	0	23.00	21.98	22.02	22.36
LTE Band 2	3MHz	QPSK	1	0	25.00	23.96	24.08	24.29
			1	7	25.00	23.93	24.13	24.25
			1	14	25.00	23.92	24.13	24.22
			8	0	24.00	22.91	23.07	23.14
			8	4	24.00	22.86	22.95	23.13
			8	7	24.00	22.94	22.94	23.12
		16QAM	15	0	24.00	22.86	22.96	23.19
			1	0	24.00	23.96	23.17	23.50
			1	7	24.00	23.87	23.14	23.49
			1	14	24.00	23.92	23.12	23.39
			8	0	23.00	21.87	22.15	22.15
			8	4	23.00	21.85	22.15	22.19
			8	7	23.00	21.90	22.10	22.23
			15	0	23.00	22.07	22.05	22.23
Band	Band Width	Modulation	RB Configuration		Tune-up	Channel/Frequency(MHz)		
			RB Size	RB Offset		18625/1852.5	18900/1880	19175/1907.5
LTE Band 2	5MHz	QPSK	1	0	25.00	23.76	24.16	24.03
			1	12	25.00	23.81	24.04	24.04
			1	24	25.00	23.76	24.08	24.00
			12	0	24.00	22.85	22.98	23.18
			12	6	24.00	22.90	23.03	23.08
			12	11	24.00	22.95	22.92	23.15
			25	0	24.00	22.89	23.02	23.25
		16QAM	1	0	24.00	23.20	22.78	23.17
			1	12	24.00	23.17	22.72	23.15
			1	24	24.00	23.20	22.78	23.11

Band	Band Width	Modulation	RB Configuration		Tune-up	Channel/Frequency(MHz)		
			RB Size	RB Offset		18650/1855	18900/1880	19150/1905
			12	0	23.00	21.87	21.92	22.27
			12	6	23.00	21.82	21.89	22.14
			12	11	23.00	21.91	21.95	22.23
			25	0	23.00	21.97	22.11	22.22
LTE Band 2	10MHz	QPSK	1	0	25.00	23.49	24.00	24.29
			1	24	25.00	23.81	23.95	24.26
			1	49	25.00	23.81	23.97	24.29
			25	0	24.00	22.83	23.02	23.23
			25	12	24.00	22.77	23.05	23.14
			25	24	24.00	22.85	23.02	23.20
		16QAM	50	0	24.00	22.91	23.01	23.24
			1	0	25.00	23.93	23.07	23.21
			1	24	25.00	23.98	23.07	23.24
			1	49	25.00	24.02	23.10	23.19
			25	0	23.00	21.89	22.15	22.21
			25	12	23.00	21.89	22.08	22.23
			25	24	23.00	21.91	22.04	22.21
			50	0	23.00	21.96	22.09	22.21
			RB Configuration		Tune-up	Channel/Frequency(MHz)		
			RB Size	RB Offset		18675/1857.5	18900/1880	19125/1902.5
LTE Band 2	15MHz	QPSK	1	0	25.00	23.99	24.20	24.02
			1	37	25.00	23.90	24.11	24.04
			1	74	25.00	24.02	24.09	24.05
			36	0	24.00	22.88	23.03	23.10
			36	18	24.00	22.84	23.08	23.05
			36	37	24.00	22.95	23.03	23.05
			75	0	24.00	22.98	23.02	23.16
		16QAM	1	0	25.00	24.00	23.18	23.86
			1	37	25.00	23.96	23.11	23.92
			1	74	25.00	24.08	23.12	23.88
			36	0	23.00	21.96	22.20	22.22
			36	18	23.00	22.05	22.14	22.18
			36	37	23.00	22.03	22.19	22.18
			75	0	23.00	22.08	22.12	22.24

Band	Band Width	Modulation	RB Configuration		Tune-up	Channel/Frequency(MHz)		
			RB Size	RB Offset		18700/1860	18900/1880	19100/1900
LTE Band 2	20MHz	QPSK	1	0	25.00	24.12	24.01	24.28
			1	49	25.00	24.11	23.90	24.31
			1	99	25.00	24.22	24.35	24.36
			50	0	24.00	22.86	23.14	23.11
			50	24	24.00	22.95	23.04	23.02
			50	49	24.00	22.99	23.10	23.09
			100	0	24.00	23.04	23.15	23.07
		16QAM	1	0	24.00	22.66	22.95	23.01
			1	49	24.00	22.70	22.83	22.97
			1	99	24.00	22.79	22.84	23.04
			50	0	23.00	22.05	22.08	22.14
			50	24	23.00	22.16	22.13	22.19
			50	49	23.00	22.16	22.11	22.20
			100	0	23.00	22.00	22.14	22.21

Band	Band Width	Modulation	RB Configuration		Tune-up	Channel/Frequency(MHz)		
			RB Size	RB Offset		20407/824.7	20525/836.5	20643/848.3
LTE Band 5	1.4MHz	QPSK	1	0	24.00	23.56	23.49	23.77
			1	2	24.00	23.54	23.56	23.72
			1	5	24.00	23.52	23.54	23.76
			3	0	24.00	23.45	23.53	23.63
			3	1	24.00	23.50	23.56	23.66
			3	2	24.00	23.42	23.47	23.54
			6	0	24.00	22.99	23.05	23.08
		16QAM	1	0	24.00	23.39	23.03	23.49
			1	2	24.00	23.37	23.03	23.48
			1	5	24.00	23.38	22.95	23.53
			3	0	23.00	22.65	22.55	22.97
			3	1	23.00	22.70	22.52	22.96
			3	2	23.00	22.63	22.52	22.92
			6	0	22.00	21.52	21.55	21.85

Band	Band Width	Modulation	RB Configuration		Tune-up	Channel/Frequency(MHz)		
			RB	RB		20415/825.5	20525/836.5	20635/847.5

Band	Band Width	Modulation	RB Configuration		Tune-up	Channel/Frequency(MHz)		
			RB Size	RB Offset		20425/826.5	20525/836.5	20625/846.5
LTE Band 5	3MHz	QPSK	1	0	24.00	23.57	23.42	23.87
			1	7	24.00	23.52	23.55	23.83
			1	14	24.00	23.55	23.49	23.79
			8	0	24.00	22.99	22.96	23.05
			8	4	24.00	23.01	22.95	22.97
			8	7	24.00	22.86	22.90	22.99
			15	0	24.00	22.86	22.98	23.10
		16QAM	1	0	24.00	23.29	22.99	23.45
			1	7	24.00	23.16	23.04	23.45
			1	14	24.00	23.06	23.01	23.40
			8	0	22.00	21.36	21.63	21.71
			8	4	22.00	21.34	21.74	21.68
			8	7	22.00	21.32	21.74	21.68
			15	0	22.00	21.49	21.57	21.72
LTE Band 5	5MHz	QPSK	1	0	24.00	23.43	23.61	23.41
			1	12	24.00	23.34	23.58	23.40
			1	24	24.00	23.35	23.63	23.41
			12	0	24.00	22.93	22.94	23.09
			12	6	24.00	22.91	22.98	23.05
			12	11	24.00	22.93	22.99	23.00
			25	0	24.00	22.94	23.05	23.05
		16QAM	1	0	23.00	22.64	22.17	22.57
			1	12	23.00	22.56	22.18	22.50
			1	24	23.00	22.51	22.15	22.49
			12	0	22.00	21.39	21.30	21.64
			12	6	22.00	21.32	21.48	21.71
			12	11	22.00	21.27	21.48	21.61
			25	0	22.00	21.43	21.66	21.65
Band	Band Width	Modulation	RB Configuration		Tune-up	Channel/Frequency(MHz)		
			RB Size	RB Offset		20450/829	20525/836.5	20600/844
LTE Band	10MHz	QPSK	1	0	24.00	23.76	23.39	23.74
			1	24	24.00	23.67	23.47	23.74

5			1	49	24.00	23.58	23.52	23.73	
			25	0	24.00	22.92	23.08	23.06	
			25	12	24.00	23.01	23.02	23.07	
			25	24	24.00	23.04	22.97	23.03	
			50	0	24.00	22.92	23.04	23.09	
	16QAM			1	0	24.00	23.35	22.43	22.48
				1	24	24.00	23.28	22.47	22.42
				1	49	24.00	23.23	22.50	22.48
				25	0	22.00	21.37	21.45	21.65
				25	12	22.00	21.49	21.58	21.53
				25	24	22.00	21.53	21.48	21.70
				50	0	22.00	21.46	21.61	21.54

Band	Band Width	Modulation	RB Configuration		Tune-up	Channel/Frequency(MHz)		
			RB Size	RB Offset		20775/2502.5	21100/2535	21425/2567.5
LTE Band 7	5MHz	QPSK	1	0	26.00	24.51	24.85	24.83
			1	12	26.00	24.96	25.19	24.99
			1	24	26.00	24.63	24.73	24.50
			12	0	25.00	24.42	24.52	23.95
			12	6	25.00	24.45	24.62	23.98
			12	11	25.00	24.47	24.46	23.80
		16QAM	1	0	25.00	24.51	24.72	24.05
			1	12	25.00	24.62	24.71	24.08
			1	24	25.00	24.70	24.77	23.75
			12	0	24.00	23.38	23.80	23.13
			12	6	24.00	23.37	23.74	23.16
			12	11	24.00	23.45	23.75	23.11
			25	0	24.00	23.61	23.73	23.38

Band	Band Width	Modulation	RB Configuration		Tune-up	Channel/Frequency(MHz)		
			RB Size	RB Offset		20800/2505	21100/2535	21400/2565
LTE Band 7	10MHz	QPSK	1	0	26.00	24.54	24.92	24.04
			1	24	26.00	24.88	25.06	24.11
			1	49	26.00	25.20	25.14	24.98
			25	0	25.00	24.49	24.61	24.20
			25	12	25.00	24.38	24.65	24.13

		16QAM	25	24	25.00	24.42	24.64	24.09
			50	0	25.00	24.45	24.59	24.13
			1	0	25.00	23.62	24.78	23.70
			1	24	25.00	23.99	24.79	23.73
			1	49	25.00	23.32	24.79	23.60
			25	0	24.00	23.58	23.78	23.36
			25	12	24.00	23.60	23.82	23.33
			25	24	24.00	23.66	23.75	23.30
			50	0	24.00	23.63	23.91	23.32
Band	Band Width	Modulation	RB Configuration		Tune-up	Channel/Frequency(MHz)		
			RB Size	RB Offset		20825/2507.5	21100/2535	21375/2562.5
LTE Band 7	15MHz	QPSK	1	0	26.00	24.68	25.07	24.31
			1	37	26.00	24.85	24.96	24.07
			1	74	26.00	25.04	24.80	24.68
			36	0	25.00	24.33	24.53	24.30
			36	18	25.00	24.49	24.63	24.13
			36	37	25.00	24.45	24.60	23.99
		16QAM	75	0	25.00	24.53	24.67	24.14
			1	0	26.00	24.73	24.72	24.32
			1	37	26.00	24.98	24.72	24.08
			1	74	26.00	25.18	24.75	24.71
			36	0	24.00	23.62	23.87	23.45
			36	18	24.00	23.69	23.76	23.30
			36	37	24.00	23.74	23.88	23.30
			75	0	24.00	23.59	23.75	23.38
Band	Band Width	Modulation	RB Configuration		Tune-up	Channel/Frequency(MHz)		
			RB Size	RB Offset		20850/2510	21100/2535	21350/2560
LTE Band 7	20MHz	QPSK	1	0	26.00	24.80	25.15	24.56
			1	49	26.00	24.93	24.93	24.15
			1	99	26.00	25.66	25.30	24.31
			50	0	25.00	24.50	24.69	24.30
			50	24	25.00	24.46	24.65	24.21
			50	49	25.00	24.55	24.68	24.24
			100	0	25.00	24.46	24.60	24.25
		16QAM	1	0	26.00	24.62	25.07	24.46
			1	49	26.00	24.79	24.90	24.13

			1	99	26.00	24.91	25.18	24.13
			50	0	24.00	23.71	23.77	23.49
			50	24	24.00	23.80	23.73	23.42
			50	49	24.00	23.82	23.68	23.41
			100	0	24.00	23.75	23.80	23.47

7.4. WLAN & Bluetooth Output Power

7.4.1. Output Power Results Of WLAN

Mode	Channel	Frequency (MHz)	Tune-up	Output Power (dBm)
802.11b	1	2412	13.00	12.43
	6	2437	13.00	12.26
	11	2462	13.00	11.49
802.11g	1	2412	13.00	12.19
	6	2437	13.00	12.07
	11	2462	13.00	11.96
802.11n HT20	1	2412	13.00	12.17
	6	2437	13.00	12.20
	11	2462	13.00	11.94
802.11n HT40	3	2422	13.00	11.78
	6	2437	13.00	12.95
	9	2452	13.00	12.21

NOTE: Power measurement results of WLAN 2.4G.

7.4.2. Output Power Results Of Bluetooth

BR+EDR	Output Power (dBm)				
	Channel	Tune-up	Data Rates		
			1M	2M	3M
	0CH	-6.100	-6.171	-6.868	-8.029
	39CH	-6.000	-7.812	-6.489	-6.774
	78CH	-6.000	-6.447	-6.591	-6.507

BLE	Channel	Tune-up	Output Power (dBm)
	0CH	-6.000	-6.054
	19CH	-7.000	-7.910
	39CH	-6.000	-6.591

8. Antenna Location

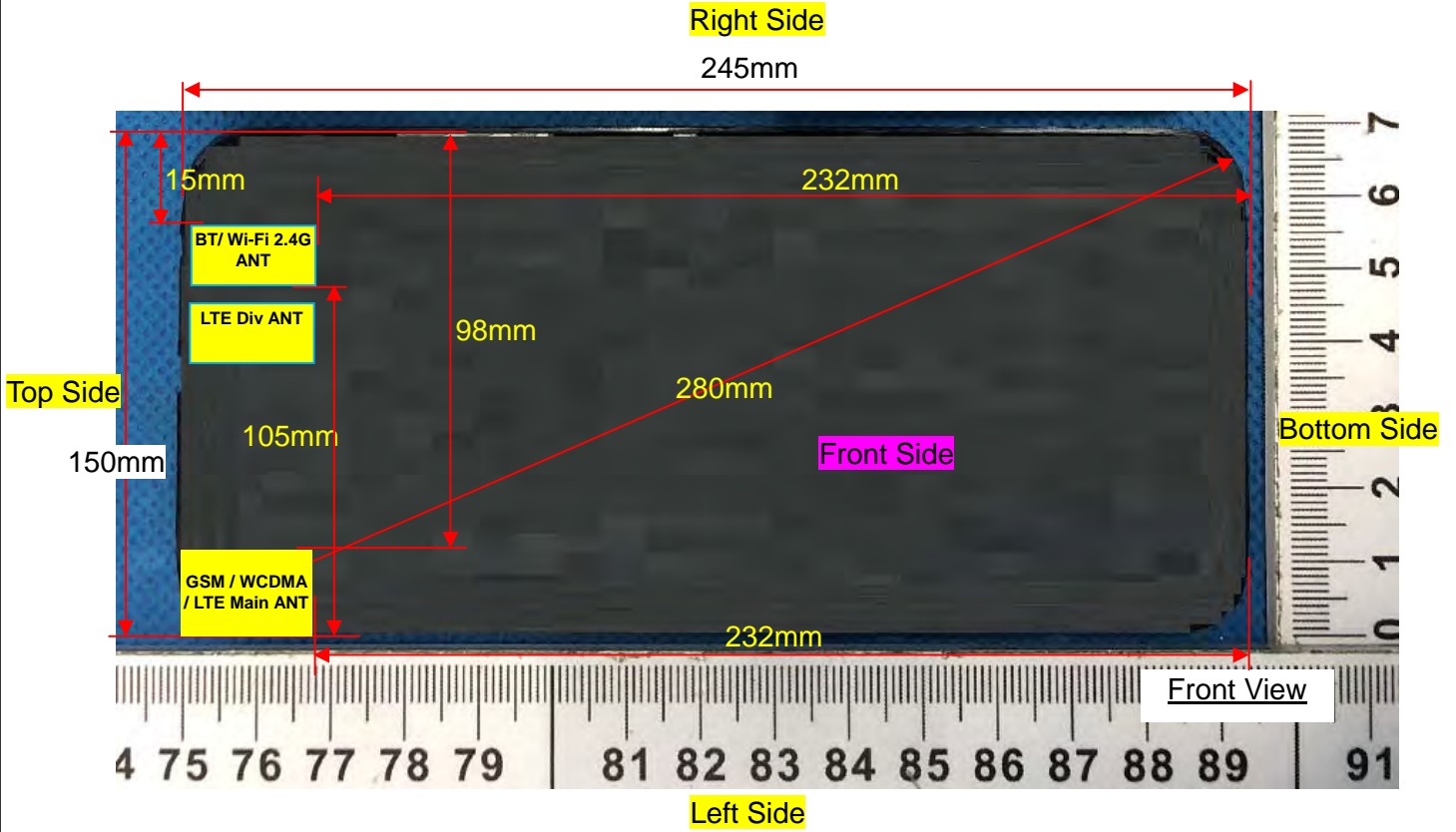

Note: Since the confidentiality request of EUT, the antenna location example diagram see as above.

Distance of the Antenna to the EUT surface/edge						
Antennas	Front Side	Back Side	Left Side	Right Side	Top Side	Bottom Side
WWAN Main	5	5	5	98	5	232
WLAN & Bluetooth	5	5	105	15	5	232

Note: When the minimum separation distance is < 5 mm, a distance of 5 mm is applied to determine SAR test exclusion.

Positions for SAR tests		
Test separation distances \leq 50 mm		
Exposure Positions	Tune-up Maximum power of WLAN 2.4G	
	13dBm	
Front Side	Antenna to user(mm)	5
	SAR exclusion threshold	6.3
	SAR testing required?	YES
Back Side	Antenna to user(mm)	5
	SAR exclusion threshold	6.3
	SAR testing required?	YES
Right Side	Antenna to user(mm)	15
	SAR exclusion threshold	2.1
	SAR testing required?	NO
Top Side	Antenna to user(mm)	5
	SAR exclusion threshold	6.3
	SAR testing required?	YES
Exposure Positions	Tune-up Maximum power of GSM850	
	34dBm	
Front Side	Antenna to user(mm)	5
	SAR exclusion threshold	462.8
	SAR testing required?	YES
Back Side	Antenna to user(mm)	5
	SAR exclusion threshold	462.8
	SAR testing required?	YES
Left Side	Antenna to user(mm)	5
	SAR exclusion threshold	462.8
	SAR testing required?	YES
Top Side	Antenna to user(mm)	5
	SAR exclusion threshold	462.8
	SAR testing required?	YES
Exposure Positions	Tune-up Maximum power of GSM1900	
	31dBm	
Front Side	Antenna to user(mm)	5
	SAR exclusion threshold	348
	SAR testing required?	YES
Back Side	Antenna to user(mm)	5
	SAR exclusion threshold	348
	SAR testing required?	YES
Left Side	Antenna to user(mm)	5

	SAR exclusion threshold	348
	SAR testing required?	YES
Top Side	Antenna to user(mm)	5
	SAR exclusion threshold	348
	SAR testing required?	YES
Exposure Positions	Tune-up Maximum power of WCDMA Band 2	
	24dBm	
Front Side	Antenna to user(mm)	5
	SAR exclusion threshold	69.4
	SAR testing required?	YES
Back Side	Antenna to user(mm)	5
	SAR exclusion threshold	69.4
	SAR testing required?	YES
Left Side	Antenna to user(mm)	5
	SAR exclusion threshold	69.4
	SAR testing required?	YES
Top Side	Antenna to user(mm)	5
	SAR exclusion threshold	69.4
	SAR testing required?	YES
Exposure Positions	Tune-up Maximum power of WCDMA Band 5	
	24dBm	
Front Side	Antenna to user(mm)	5
	SAR exclusion threshold	46.2
	SAR testing required?	YES
Back Side	Antenna to user(mm)	5
	SAR exclusion threshold	46.2
	SAR testing required?	YES
Left Side	Antenna to user(mm)	5
	SAR exclusion threshold	46.2
	SAR testing required?	YES
Top Side	Antenna to user(mm)	5
	SAR exclusion threshold	46.2
	SAR testing required?	YES
Exposure Positions	Tune-up Maximum power of LTE Band 2	
	25dBm	
Front Side	Antenna to user(mm)	5
	SAR exclusion threshold	87.4
	SAR testing required?	YES
Back Side	Antenna to user(mm)	5
	SAR exclusion threshold	87.4

	SAR testing required?	YES
Left Side	Antenna to user(mm)	5
	SAR exclusion threshold	87.4
	SAR testing required?	YES
Top Side	Antenna to user(mm)	5
	SAR exclusion threshold	87.4
	SAR testing required?	YES
Exposure Positions	Tune-up Maximum power of LTE Band 5	
	24dBm	
Front Side	Antenna to user(mm)	5
	SAR exclusion threshold	46.3
	SAR testing required?	YES
Back Side	Antenna to user(mm)	5
	SAR exclusion threshold	46.3
	SAR testing required?	YES
Left Side	Antenna to user(mm)	5
	SAR exclusion threshold	46.3
	SAR testing required?	YES
Top Side	Antenna to user(mm)	5
	SAR exclusion threshold	46.3
	SAR testing required?	YES
Exposure Positions	Tune-up Maximum power of LTE Band 7	
	26dBm	
Front Side	Antenna to user(mm)	5
	SAR exclusion threshold	127.6
	SAR testing required?	YES
Back Side	Antenna to user(mm)	5
	SAR exclusion threshold	127.6
	SAR testing required?	YES
Left Side	Antenna to user(mm)	5
	SAR exclusion threshold	127.6
	SAR testing required?	YES
Top Side	Antenna to user(mm)	5
	SAR exclusion threshold	127.6
	SAR testing required?	YES

NOTE: Refer to section 4.3.1 of KDB 447498 D01.

Positions for SAR tests	
Test separation distances > 50 mm	
Exposure Positions	Tune-up Maximum power of WLAN 2.4G

	13dBm	19.95mW
Left Side	Antenna to user(mm)	105
	SAR exclusion threshold(mW)	646
	SAR testing required?	NO
Bottom Side	Antenna to user(mm)	232
	SAR exclusion threshold(mW)	1916
	SAR testing required?	NO
Exposure Positions	Tune-up Maximum power of GSM850	
	34dBm	2511.9mW
Right Side	Antenna to user(mm)	98
	SAR exclusion threshold(mW)	436
	SAR testing required?	YES
Bottom Side	Antenna to user(mm)	232
	SAR exclusion threshold(mW)	1194
	SAR testing required?	YES
Exposure Positions	Tune-up Maximum power of GSM1900	
	31dBm	1258.9mW
Right Side	Antenna to user(mm)	98
	SAR exclusion threshold(mW)	589
	SAR testing required?	YES
Bottom Side	Antenna to user(mm)	232
	SAR exclusion threshold(mW)	1929
	SAR testing required?	NO
Exposure Positions	Tune-up Maximum power of WCDMA Band 2	
	24dBm	251.2mW
Right Side	Antenna to user(mm)	98
	SAR exclusion threshold(mW)	589
	SAR testing required?	NO
Bottom Side	Antenna to user(mm)	232
	SAR exclusion threshold(mW)	1929
	SAR testing required?	NO
Exposure Positions	Tune-up Maximum power of WCDMA Band 5	
	24dBm	251.2mW
Right Side	Antenna to user(mm)	98
	SAR exclusion threshold(mW)	435
	SAR testing required?	NO
Bottom Side	Antenna to user(mm)	232
	SAR exclusion threshold(mW)	1191
	SAR testing required?	NO
Exposure Positions	Tune-up Maximum power of LTE Band 2	

	25dBm	316.2mW
Right Side	Antenna to user(mm)	98
	SAR exclusion threshold(mW)	589
	SAR testing required?	NO
Bottom Side	Antenna to user(mm)	232
	SAR exclusion threshold(mW)	1929
	SAR testing required?	NO
Exposure Positions	Tune-up Maximum power of LTE Band 5	
	24dBm	251.2mW
Right Side	Antenna to user(mm)	98
	SAR exclusion threshold(mW)	435
	SAR testing required?	NO
Bottom Side	Antenna to user(mm)	232
	SAR exclusion threshold(mW)	1193
	SAR testing required?	NO
Exposure Positions	Tune-up Maximum power LTE Band 7	
	26dBm	398.1mW
Right Side	Antenna to user(mm)	98
	SAR exclusion threshold(mW)	576
	SAR testing required?	NO
Bottom Side	Antenna to user(mm)	232
	SAR exclusion threshold(mW)	1916
	SAR testing required?	NO

NOTE: Refer to section 4.3.1 of KDB 447498 D01.

9. Stand-alone SAR test exclusion

Refer to FCC KDB 447498D01, the 1-g SAR and 10-g SAR test exclusion thresholds for 100 MHz to 6 GHz at test separation distances ≤ 50 mm are determined by:

$[(\text{max. power of channel, including tune-up tolerance, mW}) / (\text{min. test separation distance, mm})] \cdot [\sqrt{f_{(\text{GHz})}}] \leq 3.0$ for 1-g SAR and ≤ 7.5 for 10-g extremity SAR, where:

- $f_{(\text{GHz})}$ is the RF channel transmit frequency in GHz
- Power and distance are rounded to the nearest mW and mm before calculation
- The result is rounded to one decimal place for comparison

When the minimum test separation distance is < 5 mm, a distance of 5 mm is applied to determine SAR test exclusion.

Mode	P_{max} (dBm)	P_{max} (mW)	Distance (mm)	f (GHz)	Calculation Result	SAR Exclusion threshold	SAR test exclusion
Bluetooth	-6.000	0.251	5	2.480	0.08	3.0	Yes

NOTE: Standalone SAR test exclusion for Bluetooth

When standalone SAR test exclusion applies to an antenna that transmits simultaneously with other antennas, the standalone SAR must be estimated according to following to determine simultaneous transmission SAR test exclusion:

$[(\text{max. power of channel, including tune-up tolerance, mW}) / (\text{min. test separation distance, mm})] \cdot [\sqrt{f_{(\text{GHz})}} / x] \text{ W/kg}$ for test separation distances ≤ 50 mm, where $x = 7.5$ for 1-g SAR and $x = 18.75$ for 10-g SAR.

When the minimum test separation distance is < 5 mm, a distance of 5 mm is applied to determine SAR test exclusion.

Mode	Position	P_{max} (dBm)	P_{max} (mW)	Distance (mm)	f (GHz)	x	Estimated SAR (W/Kg)
Bluetooth	Body	-6.000	0.251	5	2.480	7.5	0.011

NOTE: Estimated SAR calculation for Bluetooth.

10. SAR Results

10.1. SAR measurement results

10.1.1. SAR measurement Result of GSM850

Test Position of Body with 0mm	Test channel /Freq.	Test Mode	SAR Value (W/kg)		Power Drift ($\pm 5\%$)	Conducted power (dBm)	Tune-up power (dBm)	Scaled SAR 1g (W/Kg)
			1g	10g				
Front Side	189/836.4	GPRS(GMSK 2TS)	0.700	0.371	-1.740	31.48	32.00	0.789
Back Side	189/836.4	GPRS(GMSK 2TS)	0.914	0.490	-0.210	31.48	32.00	1.030
Back Side Repeated	189/836.4	GPRS(GMSK 2TS)	0.910	0.487	-0.330	31.48	32.00	1.026
Left Side	189/836.4	GPRS(GMSK 2TS)	0.664	0.360	-3.140	31.48	32.00	0.748
Right Side	189/836.4	GPRS(GMSK 2TS)	0.452	0.247	-3.350	31.48	32.00	0.509
Top Side	189/836.4	GPRS(GMSK 2TS)	0.340	0.181	-4.640	31.48	32.00	0.383
Bottom Side	189/836.4	GPRS(GMSK 2TS)	0.240	0.081	-3.640	31.48	32.00	0.271
Back Side	128/824.2	GPRS(GMSK 2TS)	0.765	0.390	-0.210	31.63	32.00	0.833
Back Side	251/848.8	GPRS(GMSK 2TS)	0.774	0.392	-0.430	31.49	32.00	0.870

NOTE: Body SAR test results of GSM850

10.1.2. SAR measurement Result of GSM1900

Test Position of Body with 0mm	Test channel /Freq.	Test Mode	SAR Value (W/kg)		Power Drift ($\pm 5\%$)	Conducted power (dBm)	Tune-up power (dBm)	Scaled SAR 1g (W/Kg)
			1g	10g				
Front Side	661/1880	GPRS(GMSK 3TS)	0.261	0.129	2.32	26.78	27.00	0.275
Back Side	661/1880	GPRS(GMSK 3TS)	0.323	0.154	0.30	26.78	27.00	0.340
Left Side	661/1880	GPRS(GMSK 3TS)	0.245	0.112	-2.10	26.78	27.00	0.258
Right Side	661/1880	GPRS(GMSK 3TS)	0.160	0.078	1.00	26.78	27.00	0.168
Top Side	661/1880	GPRS(GMSK 3TS)	0.112	0.055	2.99	26.78	27.00	0.118

NOTE: Body SAR test results of GSM1900

10.1.3. SAR measurement Result of WCDMA Band 2

Test Position of Body with	Test channel	Test Mode	SAR Value (W/kg)	Power Drift	Conducted power	Tune-up power	Scaled SAR
----------------------------	--------------	-----------	------------------	-------------	-----------------	---------------	------------

0mm	/Freq.		1g	10g	(±5%)	(dBm)	(dBm)	1g (W/Kg)
Front Side	9400/1880	RMC12.2K	0.411	0.215	2.64	23.50	24.00	0.461
Back Side	9400/1880	RMC12.2K	0.497	0.232	-1.54	23.50	24.00	0.558
Left Side	9400/1880	RMC12.2K	0.373	0.186	-4.71	23.50	24.00	0.419
Top Side	9400/1880	RMC12.2K	0.190	0.086	3.31	23.50	24.00	0.213

NOTE: Body SAR test results of WCDMA Band 2

10.1.4. SAR measurement Result of WCDMA Band 5

Test Position of Body with 0mm	Test channel /Freq.	Test Mode	SAR Value (W/kg)		Power Drift (±5%)	Conducted power (dBm)	Tune-up power (dBm)	Scaled SAR 1g (W/Kg)
			1g	10g				
Front Side	4182/836.4	RMC12.2K	0.117	0.063	-3.38	23.38	24.00	0.135
Back Side	4182/836.4	RMC12.2K	0.152	0.088	0.51	23.38	24.00	0.175
Left Side	4182/836.4	RMC12.2K	0.118	0.068	-0.48	23.38	24.00	0.136
Top Side	4182/836.4	RMC12.2K	0.059	0.036	-0.04	23.38	24.00	0.068

NOTE: Body SAR test results of WCDMA Band 5

10.1.5. SAR measurement Result of LTE Band 2

Test Position of Body with 0mm	Test channel /Freq.	Test Mode	SAR Value (W/kg)		Power Drift (±5%)	Conduc ted power (dBm)	Tune-u p power (dBm)	Scaled SAR 1g (W/Kg)
			1g	10g				
1RB								
Front Side	18900/1880	20M QPSK(1,99)	0.627	0.263	-4.28	24.35	25.00	0.728
Back Side	18900/1880	20M QPSK(1,99)	1.046	0.483	0.73	24.35	25.00	1.215
Back Side Repeated	18900/1880	20M QPSK(1,99)	1.040	0.480	0.38	24.35	25.00	1.208
Left Side	18900/1880	20M QPSK(1,99)	0.634	0.284	-2.55	24.35	25.00	0.736
Top Side	18900/1880	20M QPSK(1,99)	0.372	0.173	-0.58	24.35	25.00	0.432
Back Side	18700/1860	20M QPSK(1,99)	0.789	0.358	1.25	24.22	25.00	0.944
Back Side	19100/1900	20M QPSK(1,99)	0.763	0.349	0.34	24.36	25.00	0.884
50%RB								

Front Side	18900/1880	1.4M QPSK(3,1)	0.551	0.208	-3.01	24.97	25.00	0.555
Back Side	18900/1880	1.4M QPSK(3,1)	0.740	0.425	-4.57	24.97	25.00	0.745
Left Side	18900/1880	1.4M QPSK(3,1)	0.587	0.245	-4.75	24.97	25.00	0.591
Top Side	18900/1880	1.4M QPSK(3,1)	0.319	0.164	1.42	24.97	25.00	0.321
100%RB								
Back Side	18900/1880	20M QPSK(100,0)	0.523	0.261	-3.01	23.15	24.00	0.636

NOTE: Body SAR test results of LTE Band 2

10.1.6. SAR measurement Result of LTE Band 5

Test Position of Body with 0mm	Test channel /Freq.	Test Mode	SAR Value (W/kg)		Power Drift (±5%)	Conducted power (dBm)	Tune-up power (dBm)	Scaled SAR 1g (W/Kg)
			1g	10g				
1RB								
Front Side	20525/836.5	10M QPSK(1,0)	0.252	0.140	-1.45	23.39	24.00	0.290
Back Side	20525/836.5	10M QPSK(1,0)	0.332	0.183	0.10	23.39	24.00	0.382
Left Side	20525/836.5	10M QPSK(1,0)	0.242	0.137	3.49	23.39	24.00	0.278
Top Side	20525/836.5	10M QPSK(1,0)	0.126	0.074	-3.32	23.39	24.00	0.145
50%RB								
Front Side	20525/836.5	10M QPSK(25,12)	0.222	0.126	0.67	23.02	24.00	0.278
Back Side	20525/836.5	10M QPSK(25,12)	0.305	0.164	2.68	23.02	24.00	0.382
Left Side	20525/836.5	10M QPSK(25,12)	0.210	0.126	4.67	23.02	24.00	0.263
Top Side	20525/836.5	10M QPSK(25,12)	0.112	0.063	2.58	23.02	24.00	0.140

NOTE: Body SAR test results of LTE Band 5

10.1.7. SAR measurement Result of LTE Band 7

Test Position of Body with 0mm	Test channel /Freq.	Test Mode	SAR Value (W/kg)		Power Drift (±5%)	Conducted power (dBm)	Tune-up power (dBm)	Scaled SAR 1g (W/Kg)
			1g	10g				
1RB								
Front Side	21100/2535	20M QPSK(1,99)	0.189	0.088	0.53	25.30	26.00	0.222
Back Side	21100/2535	20M	0.250	0.112	-0.19	25.30	26.00	0.294

		QPSK(1,99)						
Left Side	21100/2535	20M QPSK(1,99)	0.188	0.089	3.95	25.30	26.00	0.221
Top Side	21100/2535	20M QPSK(1,99)	0.092	0.039	4.38	25.30	26.00	0.108
50%RB								
Front Side	21100/2535	20M QPSK(50,0)	0.171	0.075	3.92	24.69	25.00	0.184
Back Side	21100/2535	20M QPSK(50,0)	0.227	0.099	1.48	24.69	25.00	0.244
Left Side	21100/2535	20M QPSK(50,0)	0.166	0.079	1.43	24.69	25.00	0.178
Top Side	21100/2535	20M QPSK(50,0)	0.086	0.036	2.42	24.69	25.00	0.092

NOTE: Body SAR test results of LTE Band 7

10.1.8. SAR measurement Result of WLAN 2.4G

Test Position of Body with 0mm	Test channel /Freq.	Test Mode	SAR Value (W/kg)		Power Drift (±5%)	Conducted power (dBm)	Tune-up power (dBm)	Scaled SAR 1g (W/Kg)
			1g	10g				
Front Side	6/2437	802.11 b	0.190	0.104	-4.17	12.26	13.00	0.225
Back Side	6/2437	802.11 b	0.295	0.170	-0.68	12.26	13.00	0.350
Top Side	6/2437	802.11 b	0.091	0.058	0.84	12.26	13.00	0.108

NOTE: Body SAR test results of WLAN 2.4G

10.2. SAR Summation Scenario

Per KDB 447498 D01, simultaneous transmission SAR is compliant if,

- Scalar SAR summation < 1.6W/kg.
- $SPLSR = (SAR_1 + SAR_2)^{1.5} / (\text{min. separation distance, mm})$, and the peak separation distance is determined from the square root of $[(x_1-x_2)^2 + (y_1-y_2)^2 + (z_1-z_2)^2]$, where (x_1, y_1, z_1) and (x_2, y_2, z_2) are the coordinates of the extrapolated peak SAR locations in the zoom scan. If $SPLSR \leq 0.04$, simultaneously transmission SAR measurement is not necessary.

Test Position		Scaled SAR _{MAX}		Σ 1-g SAR (W/Kg)	SPLSR	Remark
		GSM 850	WLAN 2.4G			
Body	Front Side	0.789	0.225	1.014	N/A	N/A
	Back Side	1.030	0.350	1.380	N/A	N/A
	Left Side	0.748	N/A	0.748	N/A	N/A
	Right Side	0.509	N/A	0.509	N/A	N/A

	Top Side	0.383	0.108	0.491	N/A	N/A
	Bottom Side	0.271	N/A	0.271	N/A	N/A

NOTE: 1-g SAR Simultaneous Tx Combination of GSM850 and WLAN 2.4G.

Test Position		Scaled SAR _{MAX}		Σ 1-g SAR (W/Kg)	SPLSR	Remark
		GSM 1900	WLAN 2.4G			
Body	Front Side	0.275	0.225	0.500	N/A	N/A
	Back Side	0.340	0.350	0.690	N/A	N/A
	Left Side	0.258	N/A	0.258	N/A	N/A
	Right Side	0.168	N/A	0.168	N/A	N/A
	Top Side	0.118	0.108	0.108	N/A	N/A

NOTE: 1-g SAR Simultaneous Tx Combination of GSM1900 and WLAN 2.4G.

Test Position		Scaled SAR _{MAX}		Σ 1-g SAR (W/Kg)	SPLSR	Remark
		WCDMA Band 2	WLAN 2.4G			
Body	Front Side	0.461	0.225	0.686	N/A	N/A
	Back Side	0.558	0.350	0.908	N/A	N/A
	Left Side	0.419	N/A	0.419	N/A	N/A
	Right Side	N/A	N/A	0.000	N/A	N/A
	Top Side	0.213	0.108	0.108	N/A	N/A

NOTE: 1-g SAR Simultaneous Tx Combination of WCDMA Band 2 and WLAN 2.4G.

Test Position		Scaled SAR _{MAX}		Σ 1-g SAR (W/Kg)	SPLSR	Remark
		WCDMA Band 5	WLAN 2.4G			
Body	Front Side	0.135	0.225	0.360	N/A	N/A
	Back Side	0.175	0.350	0.525	N/A	N/A
	Left Side	0.136	N/A	0.136	N/A	N/A
	Right Side	N/A	N/A	0.000	N/A	N/A
	Top Side	0.068	0.108	0.108	N/A	N/A

NOTE: 1-g SAR Simultaneous Tx Combination of WCDMA Band 5 and WLAN 2.4G.

Test Position		Scaled SAR _{MAX}		Σ 1-g SAR (W/Kg)	SPLSR	Remark
		LTE Band 2	WLAN 2.4G			
Body	Front Side	0.728	0.225	0.953	N/A	N/A
	Back Side	1.215	0.350	1.565	N/A	N/A
	Left Side	0.736	N/A	0.736	N/A	N/A
	Right Side	N/A	N/A	0.000	N/A	N/A
	Top Side	0.432	0.108	0.108	N/A	N/A

NOTE: 1-g SAR Simultaneous Tx Combination of LTE Band 2 and WLAN 2.4G.

Test Position		Scaled SAR _{MAX}		Σ 1-g SAR (W/Kg)	SPLSR	Remark
		LTE Band 5	WLAN 2.4G			
Body	Front Side	0.290	0.225	0.515	N/A	N/A
	Back Side	0.382	0.350	0.732	N/A	N/A
	Left Side	0.278	N/A	0.278	N/A	N/A
	Right Side	N/A	N/A	0.000	N/A	N/A
	Top Side	0.145	0.108	0.108	N/A	N/A

NOTE: 1-g SAR Simultaneous Tx Combination of LTE Band 5 and WLAN 2.4G.

Test Position		Scaled SAR _{MAX}		Σ 1-g SAR (W/Kg)	SPLSR	Remark
		LTE Band 7	WLAN 2.4G			
Body	Front Side	0.222	0.225	0.447	N/A	N/A
	Back Side	0.294	0.350	0.644	N/A	N/A
	Left Side	0.221	N/A	0.221	N/A	N/A
	Right Side	N/A	N/A	0.000	N/A	N/A
	Top Side	0.108	0.108	0.216	N/A	N/A

NOTE: 1-g SAR Simultaneous Tx Combination of LTE Band 7 and WLAN 2.4G.

Test Position		Scaled SAR _{MAX}		Σ 1-g SAR (W/Kg)	SPLSR	Remark
		GSM 850	Bluetooth			
Body	Front Side	0.789	0.011	0.800	N/A	N/A
	Back Side	1.030	0.011	1.041	N/A	N/A
	Left Side	0.748	N/A	0.748	N/A	N/A
	Right Side	0.509	N/A	0.509	N/A	N/A
	Top Side	0.383	0.011	0.394	N/A	N/A
	Bottom Side	0.271	N/A	0.271	N/A	N/A

NOTE: 1-g SAR Simultaneous Tx Combination of GSM850 and Bluetooth.

Test Position		Scaled SAR _{MAX}		Σ 1-g SAR (W/Kg)	SPLSR	Remark
		GSM 1900	Bluetooth			
Body	Front Side	0.275	0.011	0.286	N/A	N/A
	Back Side	0.340	0.011	0.351	N/A	N/A
	Left Side	0.258	N/A	0.258	N/A	N/A
	Right Side	0.168	N/A	0.168	N/A	N/A
	Top Side	0.118	0.011	0.011	N/A	N/A

NOTE: 1-g SAR Simultaneous Tx Combination of GSM1900 and Bluetooth.

Test Position		Scaled SAR _{MAX}		Σ 1-g SAR (W/Kg)	SPLSR	Remark
		WCDMA Band 2	Bluetooth			
Body	Front Side	0.461	0.011	0.472	N/A	N/A

	Back Side	0.558	0.011	0.569	N/A	N/A
	Left Side	0.419	N/A	0.419	N/A	N/A
	Right Side	N/A	N/A	0.000	N/A	N/A
	Top Side	0.213	0.011	0.011	N/A	N/A

NOTE: 1-g SAR Simultaneous Tx Combination of WCDMA Band 2 and Bluetooth.

Test Position		Scaled SAR _{MAX}		Σ 1-g SAR (W/Kg)	SPLSR	Remark
		WCDMA Band 5	Bluetooth			
Body	Front Side	0.135	0.011	0.146	N/A	N/A
	Back Side	0.175	0.011	0.186	N/A	N/A
	Left Side	0.136	N/A	0.136	N/A	N/A
	Right Side	N/A	N/A	0.000	N/A	N/A
	Top Side	0.068	0.011	0.011	N/A	N/A

NOTE: 1-g SAR Simultaneous Tx Combination of WCDMA Band 5 and Bluetooth.

Test Position		Scaled SAR _{MAX}		Σ 1-g SAR (W/Kg)	SPLSR	Remark
		LTE Band 2	Bluetooth			
Body	Front Side	0.728	0.011	0.739	N/A	N/A
	Back Side	1.215	0.011	1.226	N/A	N/A
	Left Side	0.736	N/A	0.736	N/A	N/A
	Right Side	N/A	N/A	0.000	N/A	N/A
	Top Side	0.432	0.011	0.011	N/A	N/A

NOTE: 1-g SAR Simultaneous Tx Combination of LTE Band 2 and Bluetooth.

Test Position		Scaled SAR _{MAX}		Σ 1-g SAR (W/Kg)	SPLSR	Remark
		LTE Band 5	Bluetooth			
Body	Front Side	0.290	0.011	0.301	N/A	N/A
	Back Side	0.382	0.011	0.393	N/A	N/A
	Left Side	0.278	N/A	0.278	N/A	N/A
	Right Side	N/A	N/A	0.000	N/A	N/A
	Top Side	0.145	0.011	0.011	N/A	N/A

NOTE: 1-g SAR Simultaneous Tx Combination of LTE Band 5 and Bluetooth.

Test Position		Scaled SAR _{MAX}		Σ 1-g SAR (W/Kg)	SPLSR	Remark
		LTE Band 7	Bluetooth			
Body	Front Side	0.222	0.011	0.233	N/A	N/A
	Back Side	0.294	0.011	0.305	N/A	N/A
	Left Side	0.221	N/A	0.221	N/A	N/A
	Right Side	N/A	N/A	0.000	N/A	N/A
	Top Side	0.108	0.011	0.119	N/A	N/A

NOTE: 1-g SAR Simultaneous Tx Combination of LTE Band 7 and Bluetooth.

11. Appendix A. Photo documentation

Refer to appendix Test Setup photo---SAR

12. Appendix B. System Check Plots

Table of contents
MEASUREMENT 1 System Performance Check - SID835
MEASUREMENT 2 System Performance Check - SID1900
MEASUREMENT 3 System Performance Check - SID2450
MEASUREMENT 4 System Performance Check - SID2600

MEASUREMENT 1

A. Experimental conditions.

Area Scan	<u>dx=15mm dy=15mm, h= 5.00 mm</u>
ZoomScan	<u>5x5x7,dx=8mm dy=8mm dz=5mm</u>
Phantom	<u>Validation plane</u>
Device Position	<u>Dipole</u>
Band	<u>CW835</u>
Channels	<u>Middle</u>
Signal	<u>CW (Crest factor: 1.0)</u>

B. SAR Measurement Results

Frequency (MHz)	835.000000
Relative permittivity (real part)	54.491101
Relative permittivity (imaginary part)	21.203359
Conductivity (S/m)	0.981236
Variation (%)	4.260000

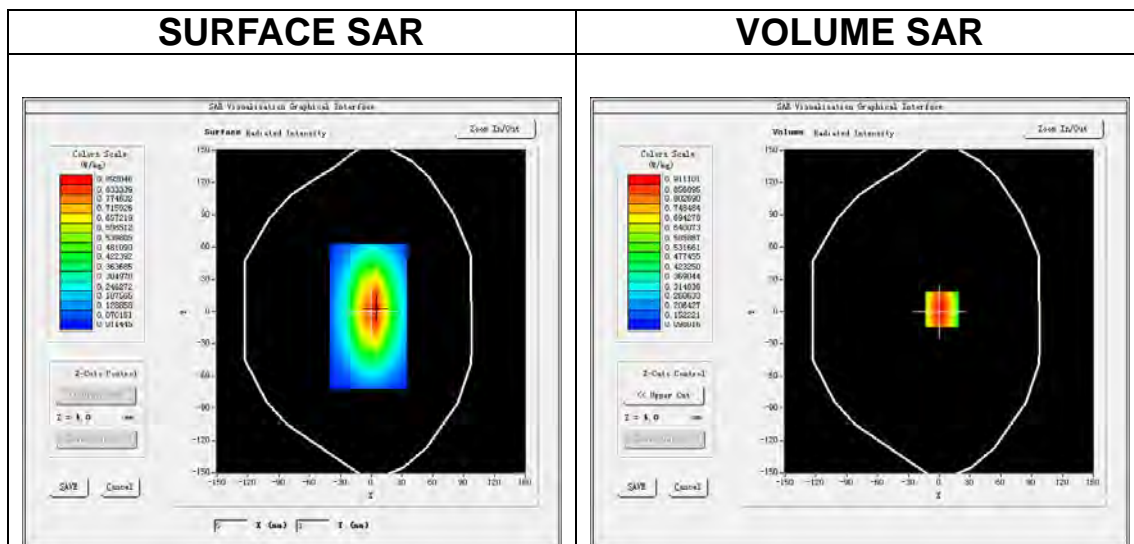

Maximum location: X=3.00, Y=2.00

SAR Peak: 1.23 W/kg

SAR 10g (W/Kg)	0.615123
SAR 1g (W/Kg)	0.979356

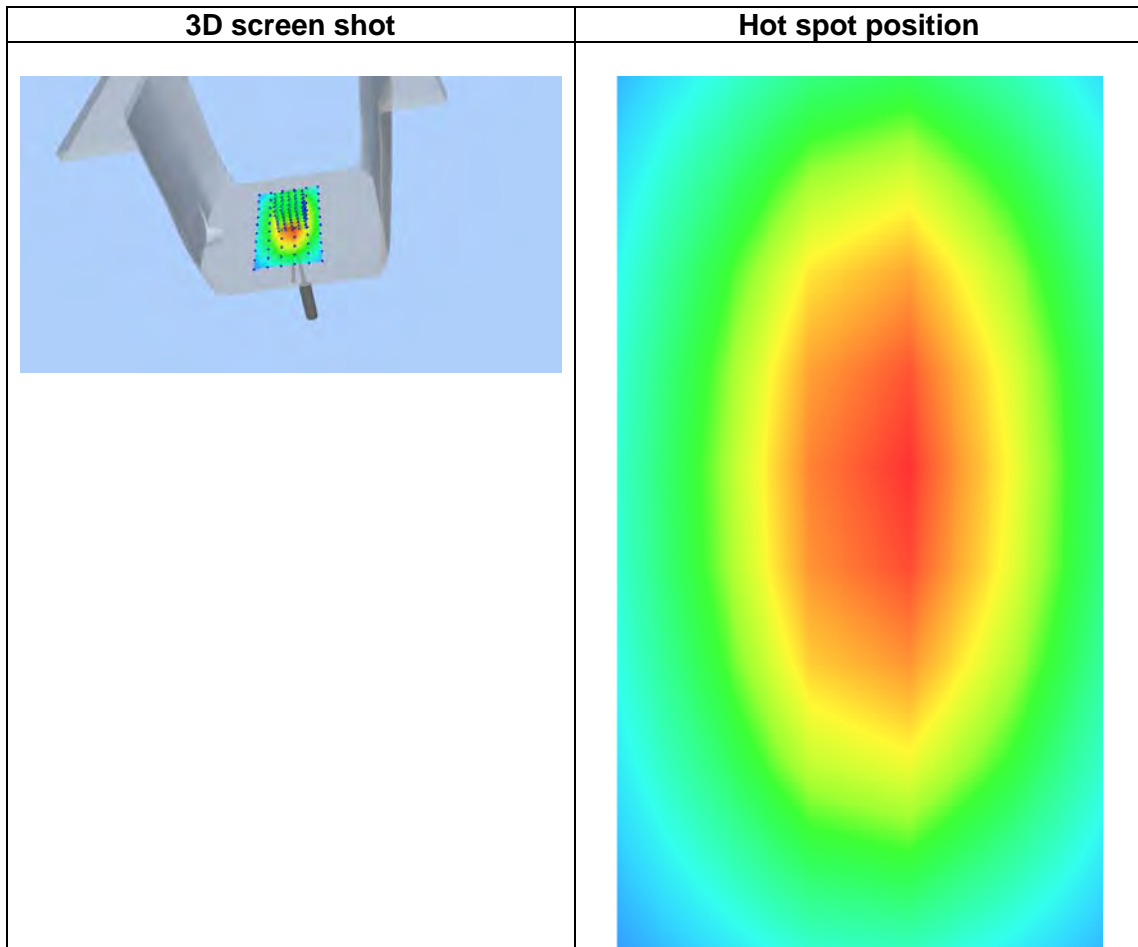
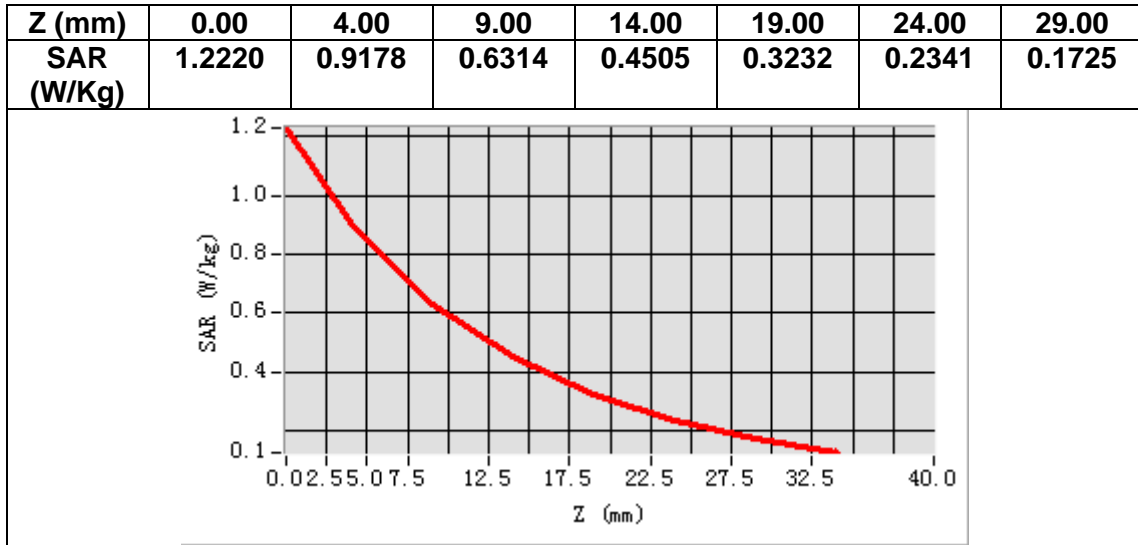

MEASUREMENT 2

A. Experimental conditions.

Area Scan	<u>dx=15mm dy=15mm, h= 5.00 mm</u>
ZoomScan	<u>5x5x7,dx=8mm dy=8mm dz=5mm</u>
Phantom	<u>Validation plane</u>
Device Position	<u>Dipole</u>
Band	<u>CW1900</u>
Channels	<u>Middle</u>
Signal	<u>CW (Crest factor: 1.0)</u>

B. SAR Measurement Results

Frequency (MHz)	1900.000000
Relative permittivity (real part)	54.233335
Relative permittivity (imaginary part)	14.503503
Conductivity (S/m)	1.533566
Variation (%)	-4.460000

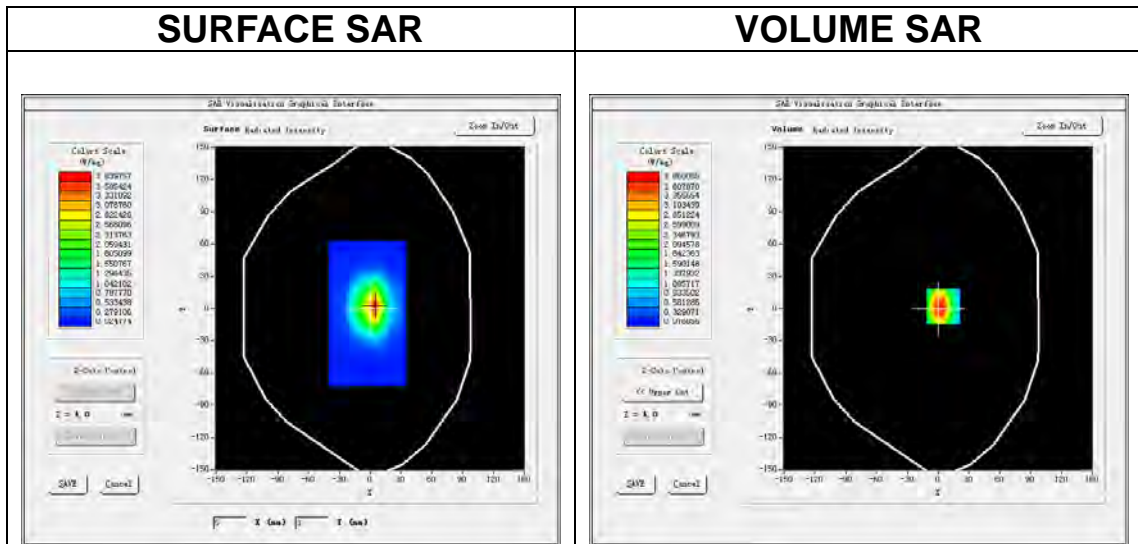

Maximum location: X=5.00, Y=2.00

SAR Peak: 6.39 W/kg

SAR 10g (W/Kg)	2.017329
SAR 1g (W/Kg)	3.955402

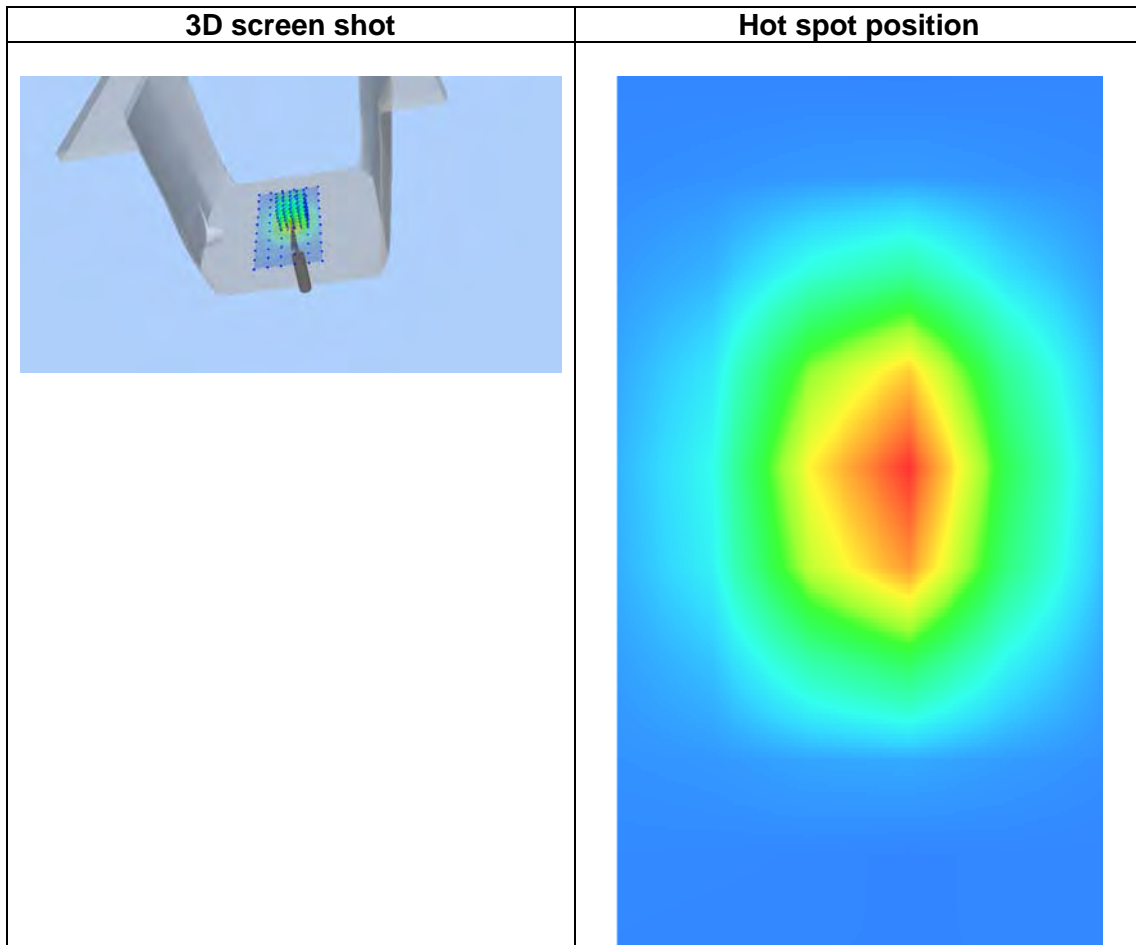
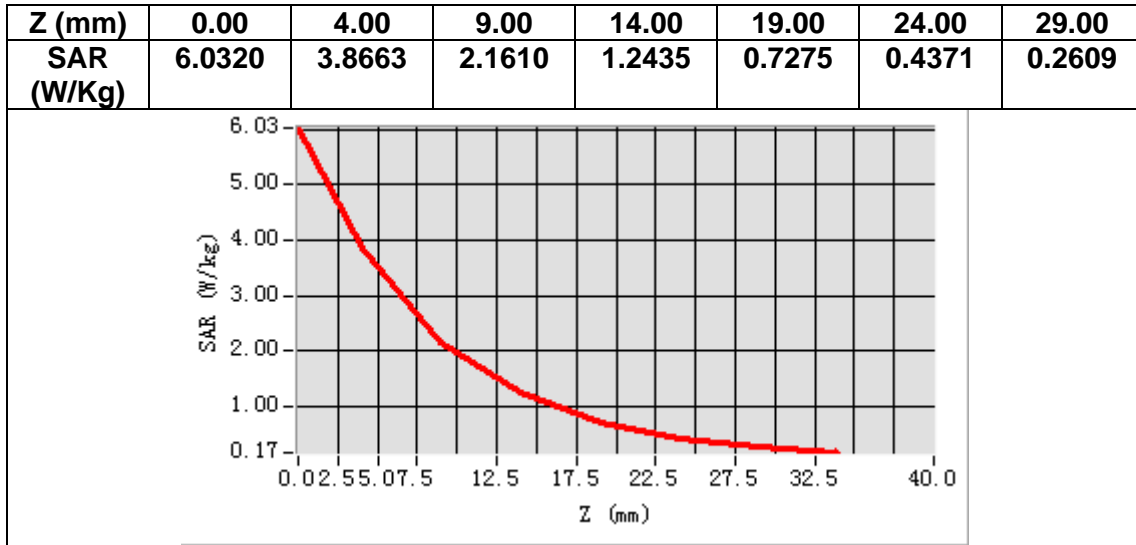

MEASUREMENT 3

A. Experimental conditions.

Area Scan	<u>dx=12mm dy=12mm, h= 5.00 mm</u>
ZoomScan	<u>7x7x7, dx=5mm dy=5mm dz=5mm</u>
Phantom	<u>Validation plane</u>
Device Position	<u>Dipole</u>
Band	<u>CW2450</u>
Channels	<u>Middle</u>
Signal	<u>CW (Crest factor: 1.0)</u>

B. SAR Measurement Results

Frequency (MHz)	2450.000000
Relative permittivity (real part)	51.491497
Relative permittivity (imaginary part)	13.853566
Conductivity (S/m)	1.892816
Variation (%)	1.420000

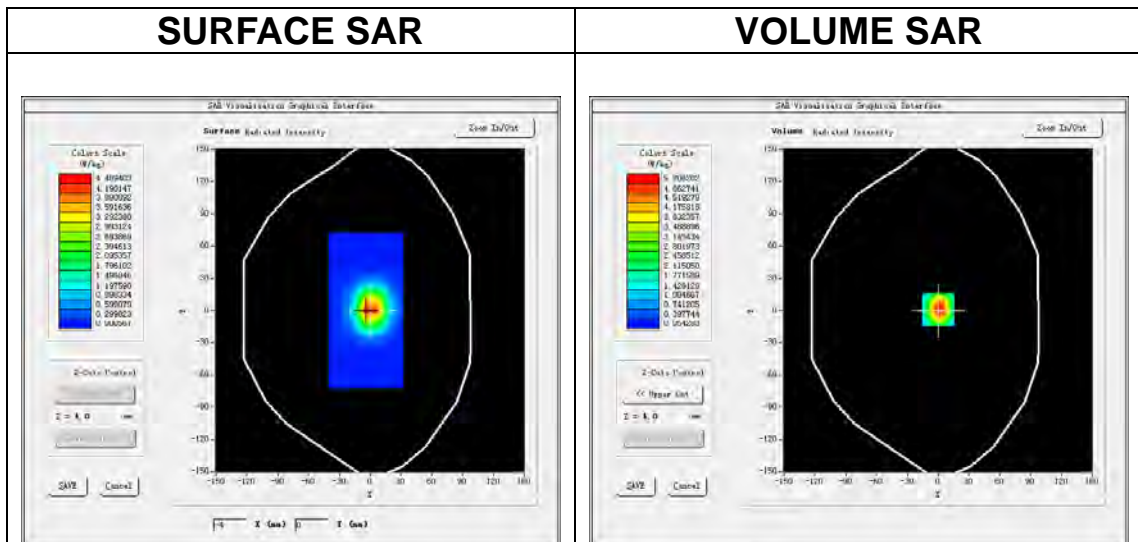

Maximum location: X=0.00, Y=1.00

SAR Peak: 8.46 W/kg

SAR 10g (W/Kg)	2.321285
SAR 1g (W/Kg)	5.336270

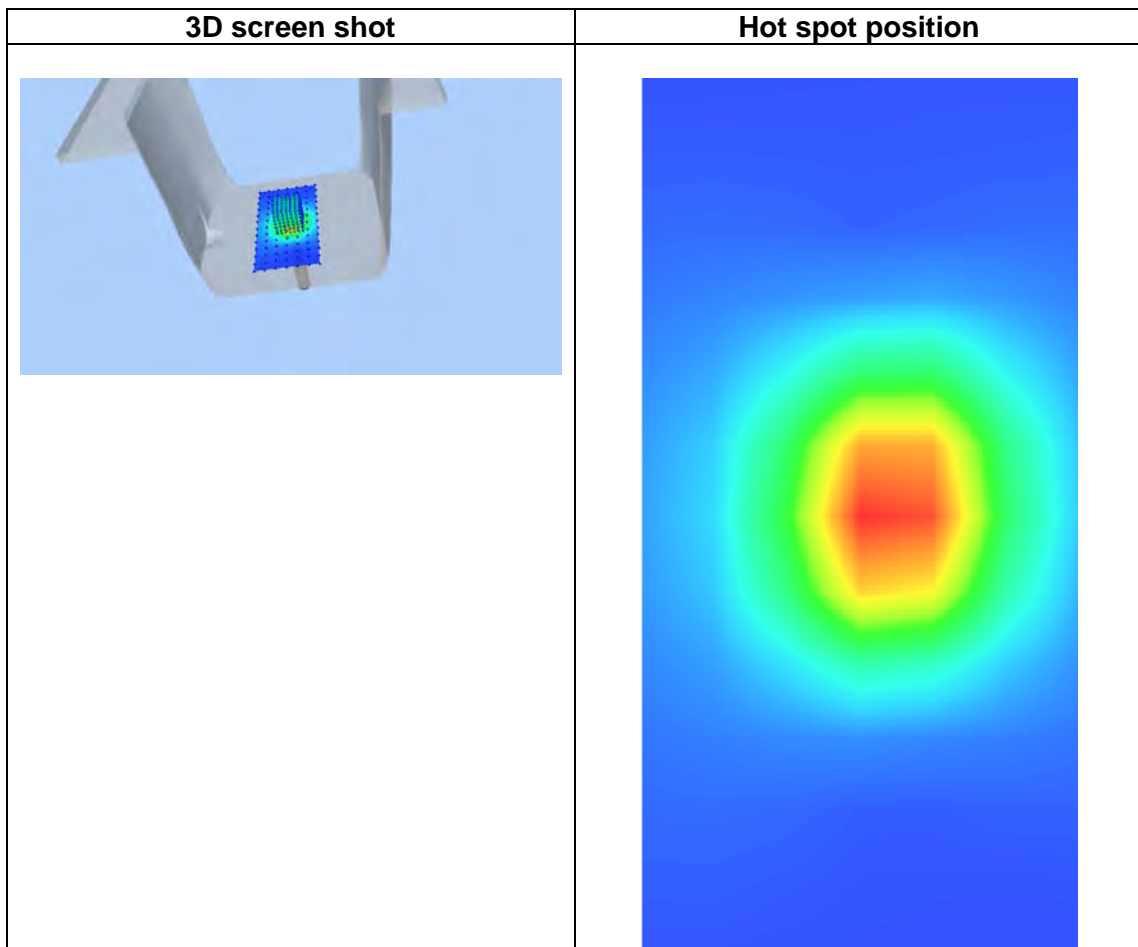
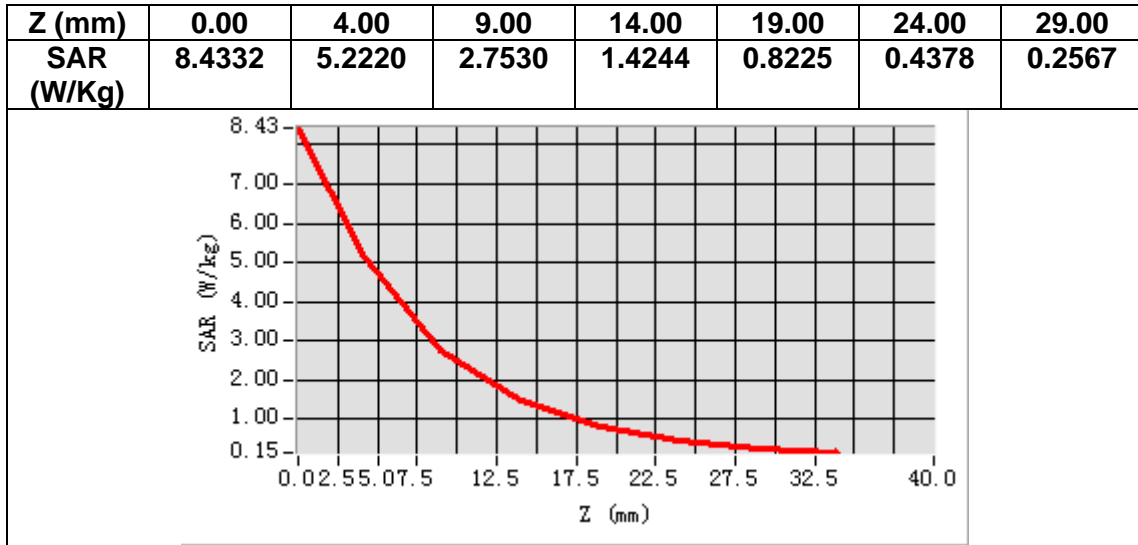

MEASUREMENT 4

A. Experimental conditions.

Area Scan	<u>dx=12mm dy=12mm, h= 5.00 mm</u>
ZoomScan	<u>7x7x7,dx=5mm dy=5mm dz=5mm</u>
Phantom	<u>Validation plane</u>
Device Position	<u>Dipole</u>
Band	<u>CW2600</u>
Channels	<u>Middle</u>
Signal	<u>CW (Crest factor: 1.0)</u>

B. SAR Measurement Results

Frequency (MHz)	2600.000000
Relative permittivity (real part)	52.822866
Relative permittivity (imaginary part)	15.350101
Conductivity (S/m)	2.223465
Variation (%)	-3.220000

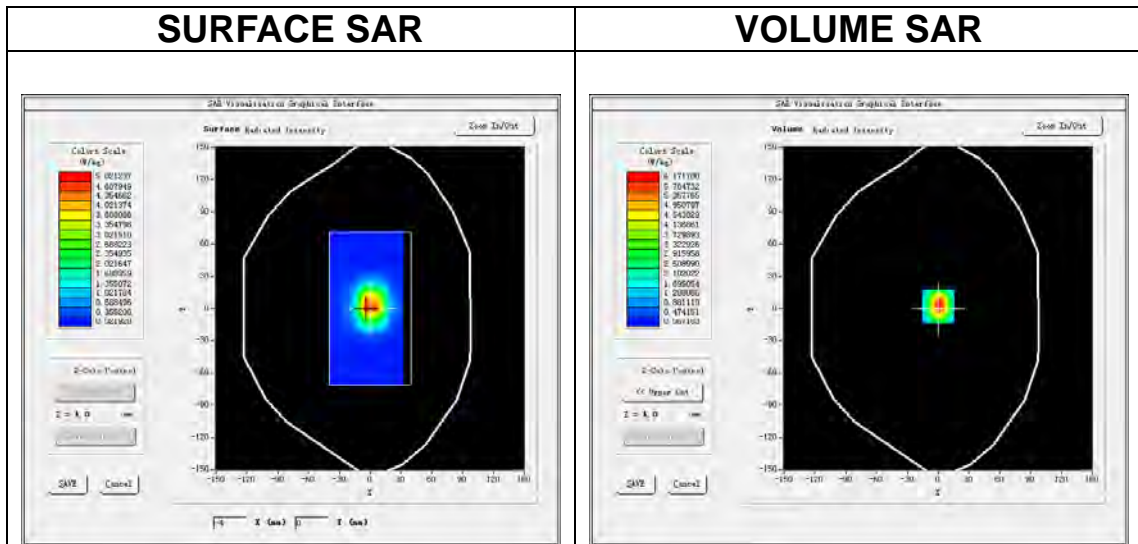

Maximum location: X=0.00, Y=2.00

SAR Peak: 9.99 W/kg

SAR 10g (W/Kg)	2.359324
SAR 1g (W/Kg)	5.013188

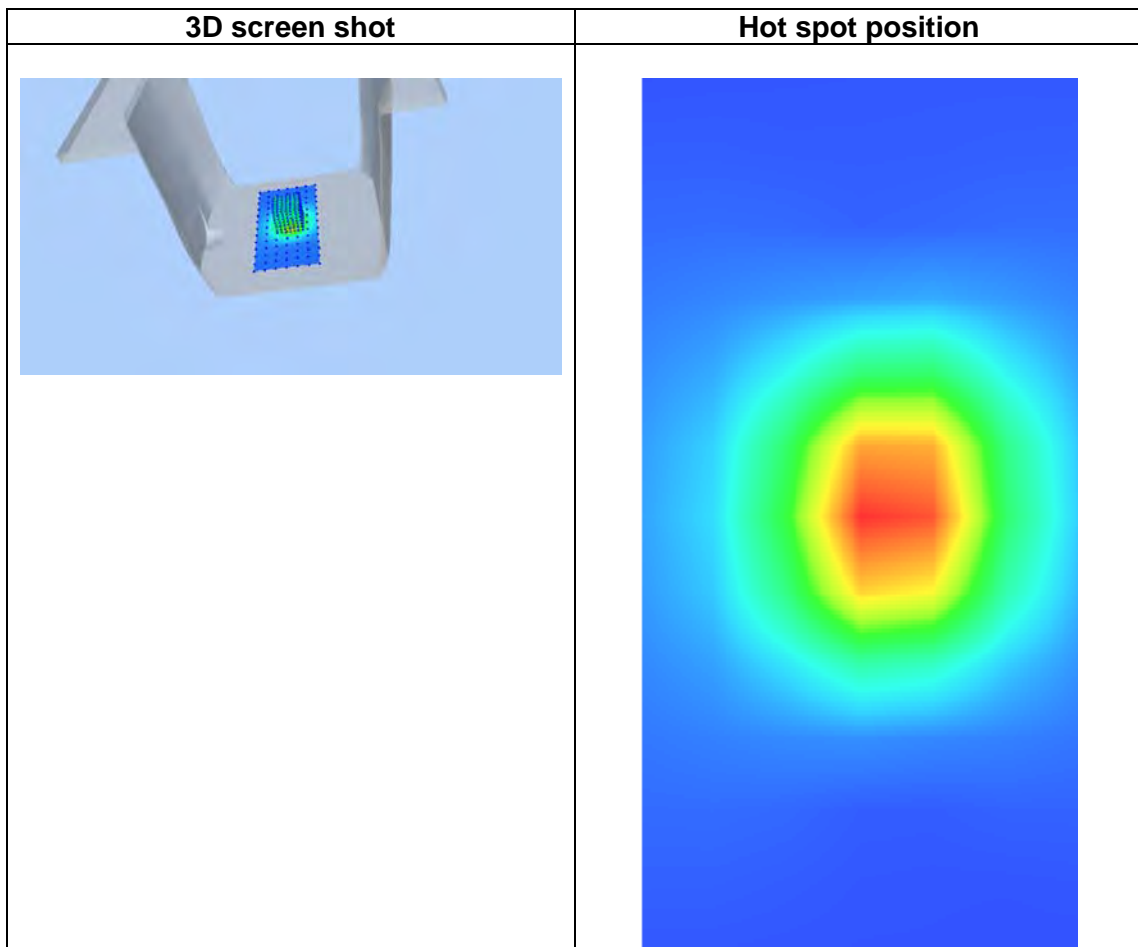
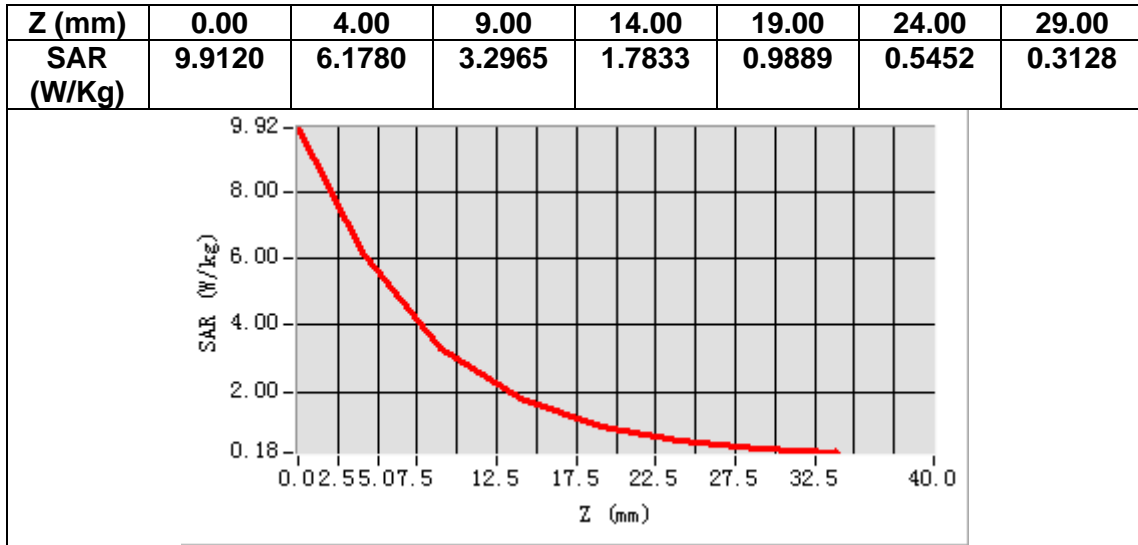

13. Appendix C. Plots of High SAR Measurement

Table of contents
MEASUREMENT 1 GSM 850
MEASUREMENT 2 GSM 1900
MEASUREMENT 3 WCDMA Band 2
MEASUREMENT 4 WCDMA Band 5
MEASUREMENT 5 WLAN 2.4G
MEASUREMENT 6 LTE Band 2
MEASUREMENT 7 LTE Band 5
MEASUREMENT 8 LTE Band 7

MEASUREMENT 1

A. Experimental conditions.

Area Scan	<u>dx=15mm dy=15mm, h= 5.00 mm</u>
ZoomScan	<u>5x5x7,dx=8mm dy=8mm dz=5mm</u>
Phantom	<u>Validation plane</u>
Device Position	<u>Body</u>
Band	<u>GSM850</u>
Channels	<u>Middle</u>
Signal	<u>TDMA (Crest factor: 4.0)</u>

B. SAR Measurement Results

Frequency (MHz)	836.400000
Relative permittivity (real part)	54.499580
Relative permittivity (imaginary part)	21.182739
Conductivity (S/m)	0.984291
Variation (%)	-0.210000

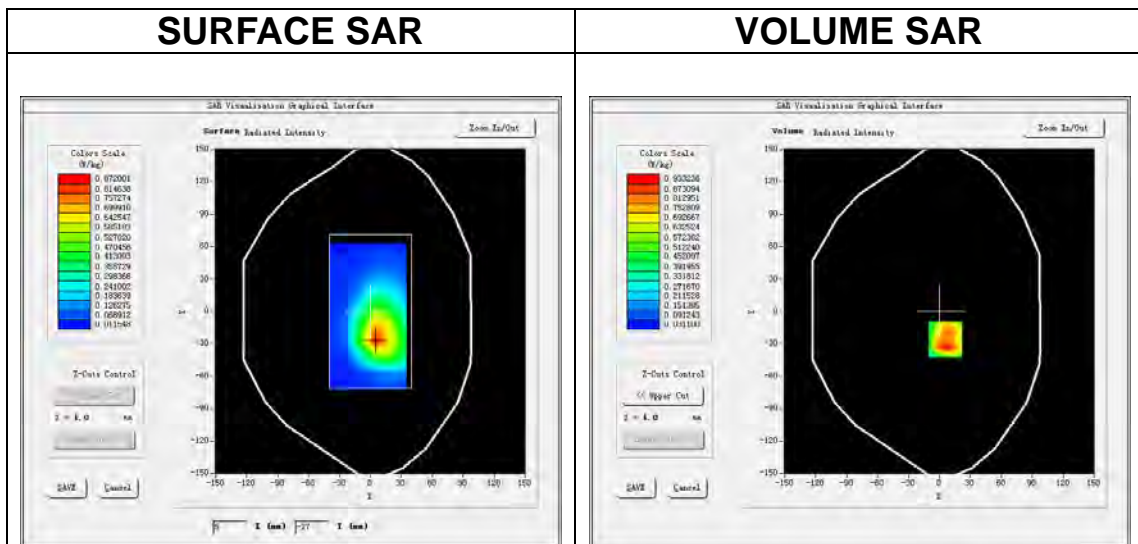

Maximum location: X=6.00, Y=-26.00

SAR Peak: 1.67 W/kg

SAR 10g (W/Kg)	0.489592
SAR 1g (W/Kg)	0.913639

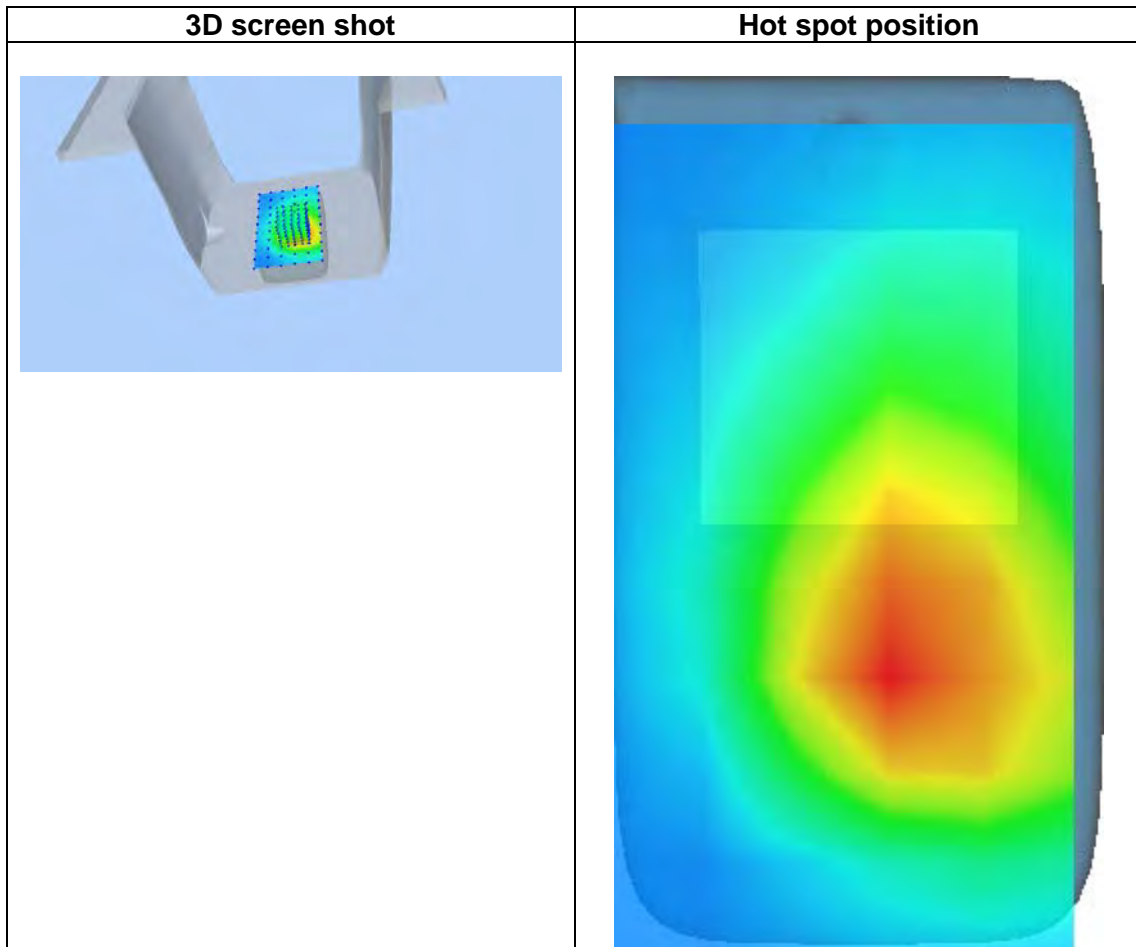
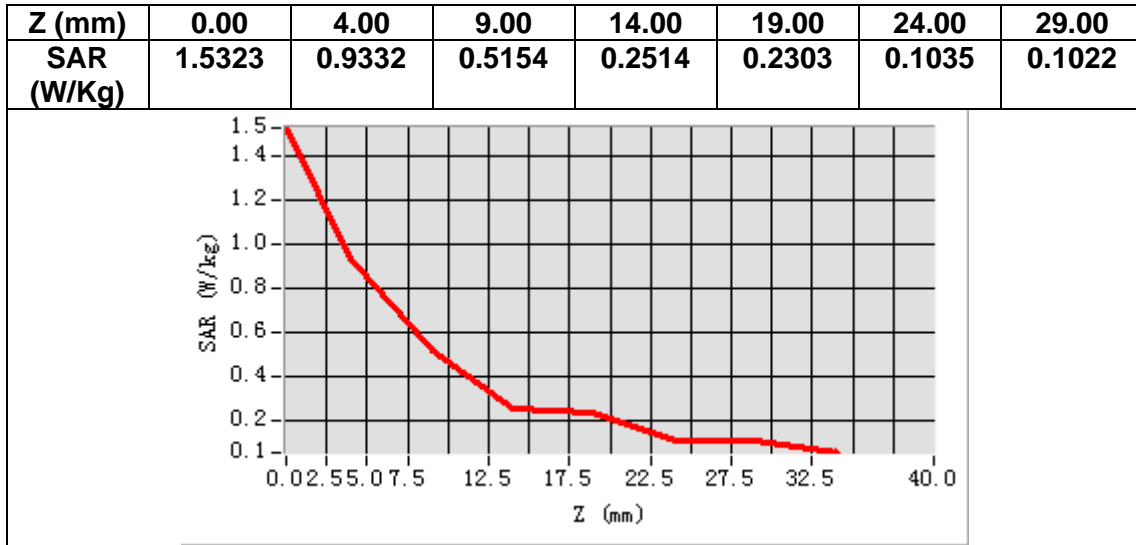

MEASUREMENT 2

A. Experimental conditions.

Area Scan	<u>dx=15mm dy=15mm, h= 5.00 mm</u>
ZoomScan	<u>5x5x7,dx=8mm dy=8mm dz=5mm</u>
Phantom	<u>Validation plane</u>
Device Position	<u>Body</u>
Band	<u>GSM1900</u>
Channels	<u>Middle</u>
Signal	<u>TDMA (Crest factor: 2.7)</u>

B. SAR Measurement Results

Frequency (MHz)	1880.000000
Relative permittivity (real part)	54.303902
Relative permittivity (imaginary part)	14.587700
Conductivity (S/m)	1.523604
Variation (%)	0.300000

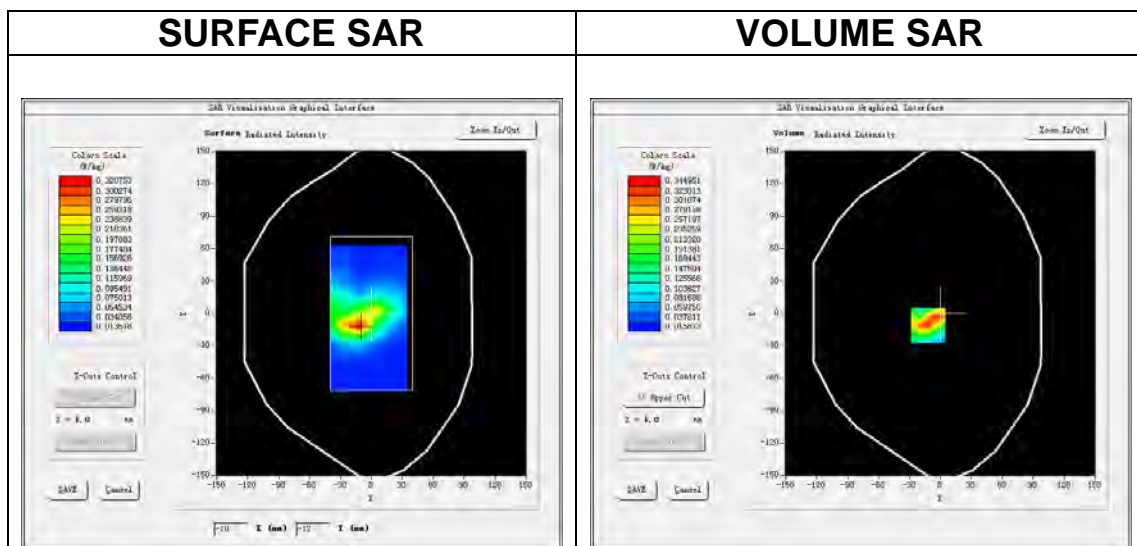

Maximum location: X=-12.00, Y=-11.00

SAR Peak: 0.62 W/kg

SAR 10g (W/Kg)	0.154142
SAR 1g (W/Kg)	0.322929

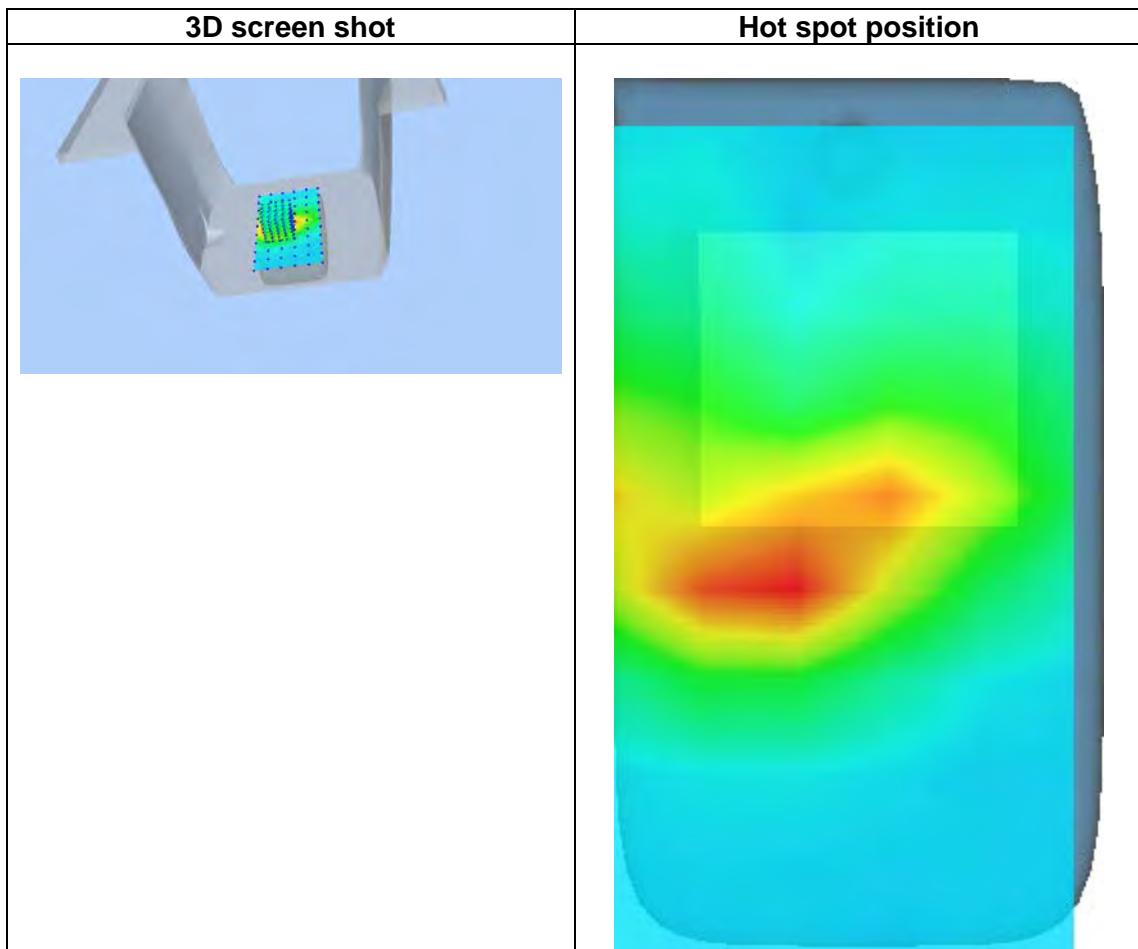
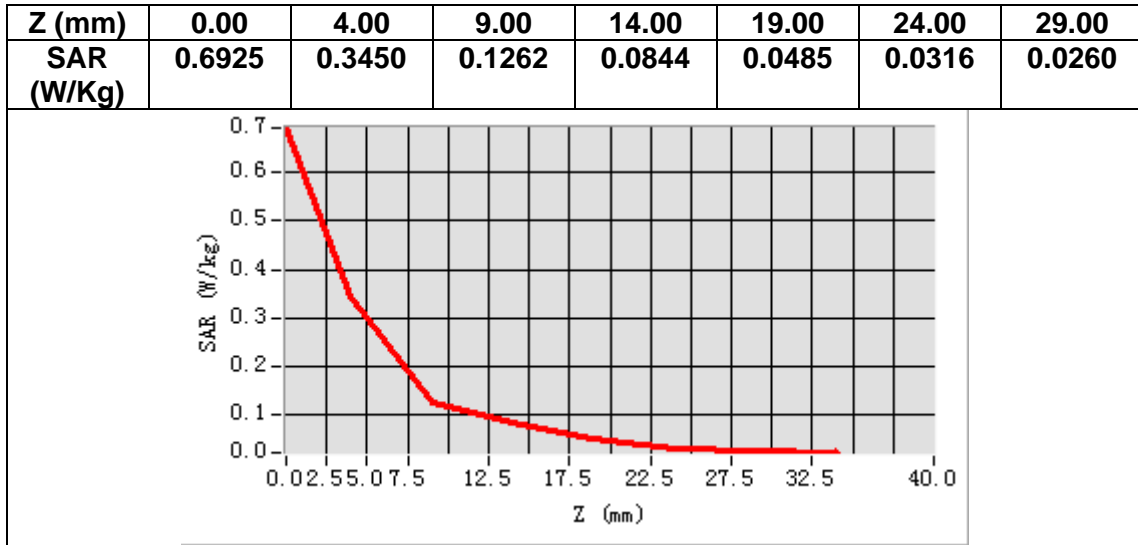

MEASUREMENT 3

A. Experimental conditions.

Area Scan	<u>dx=15mm dy=15mm, h= 5.00 mm</u>
ZoomScan	<u>5x5x7,dx=8mm dy=8mm dz=5mm</u>
Phantom	<u>Validation plane</u>
Device Position	<u>Body</u>
Band	<u>Band2 WCDMA1900</u>
Channels	<u>Middle</u>
Signal	<u>WCDMA (Crest factor: 1.0)</u>

B. SAR Measurement Results

Frequency (MHz)	1880.000000
Relative permittivity (real part)	54.303902
Relative permittivity (imaginary part)	14.587700
Conductivity (S/m)	1.523604
Variation (%)	-1.540000

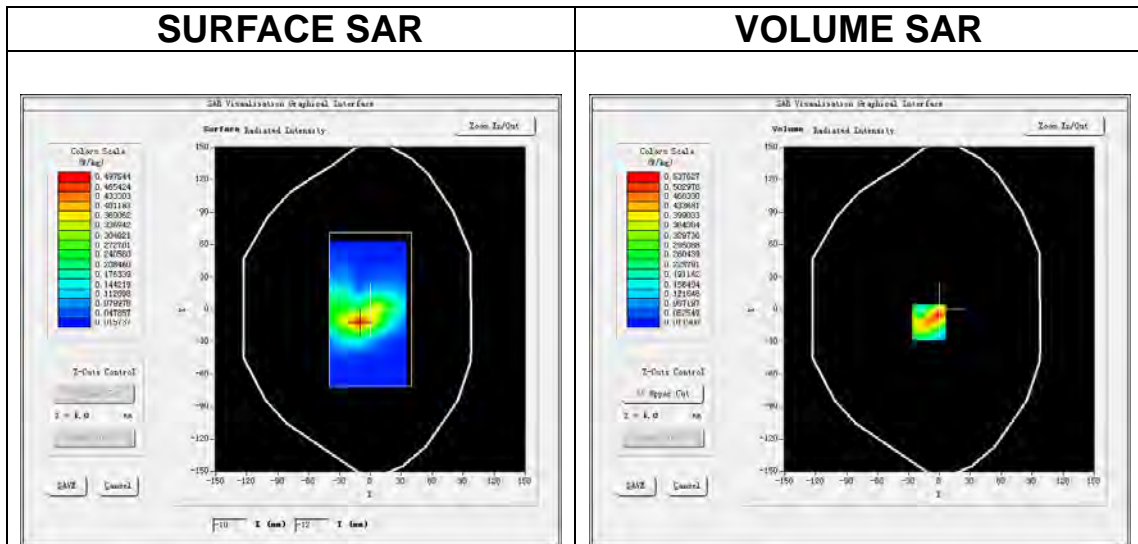

Maximum location: X=-10.00, Y=-12.00

SAR Peak: 0.97 W/kg

SAR 10g (W/Kg)	0.231548
SAR 1g (W/Kg)	0.497282

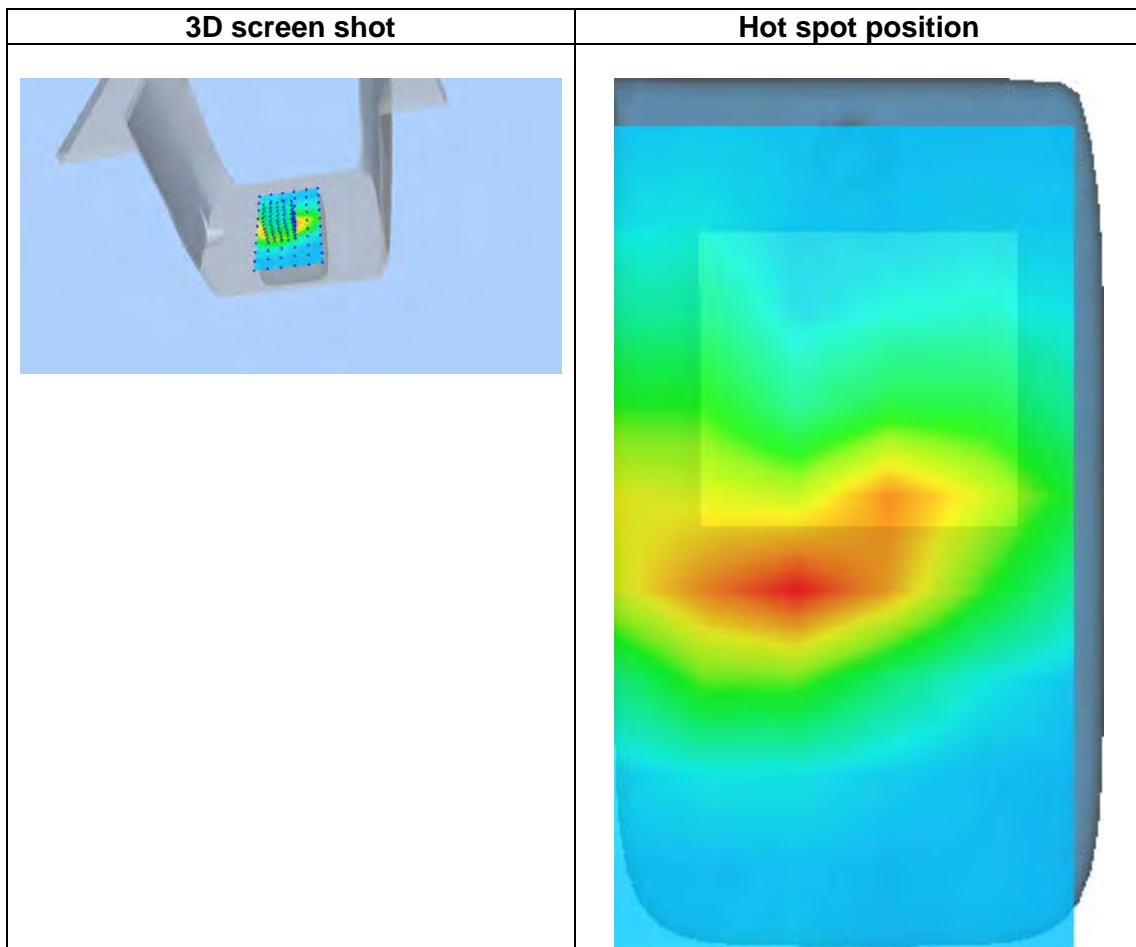
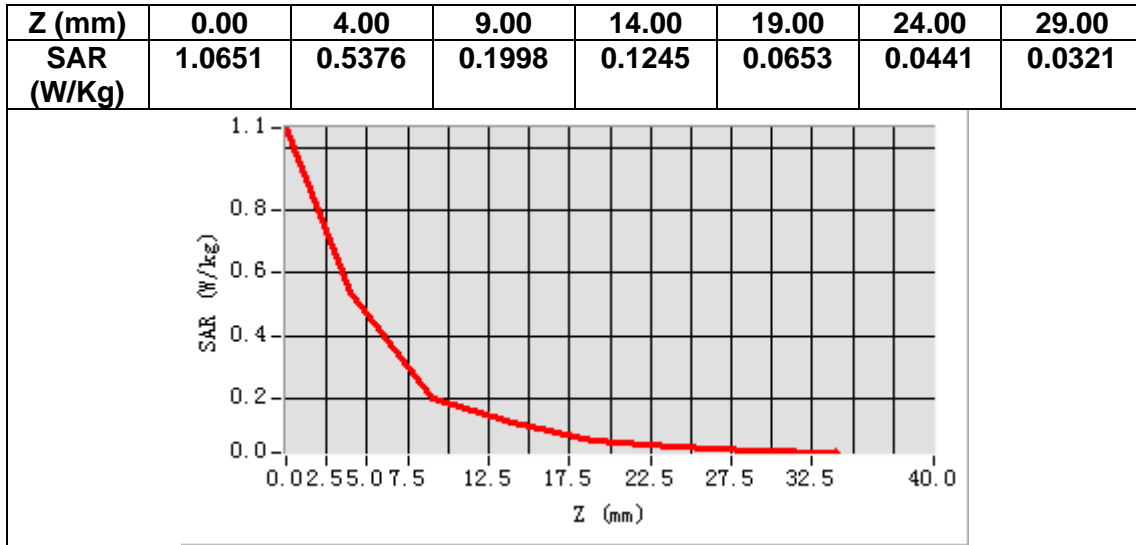

MEASUREMENT 4

A. Experimental conditions.

Area Scan	<u>dx=15mm dy=15mm, h= 5.00 mm</u>
ZoomScan	<u>5x5x7,dx=8mm dy=8mm dz=5mm</u>
Phantom	<u>Validation plane</u>
Device Position	<u>Body</u>
Band	<u>Band5_WCDMA850</u>
Channels	<u>Middle</u>
Signal	<u>WCDMA (Crest factor: 1.0)</u>

B. SAR Measurement Results

Frequency (MHz)	836.400000
Relative permittivity (real part)	54.499580
Relative permittivity (imaginary part)	21.182739
Conductivity (S/m)	0.984291
Variation (%)	0.510000

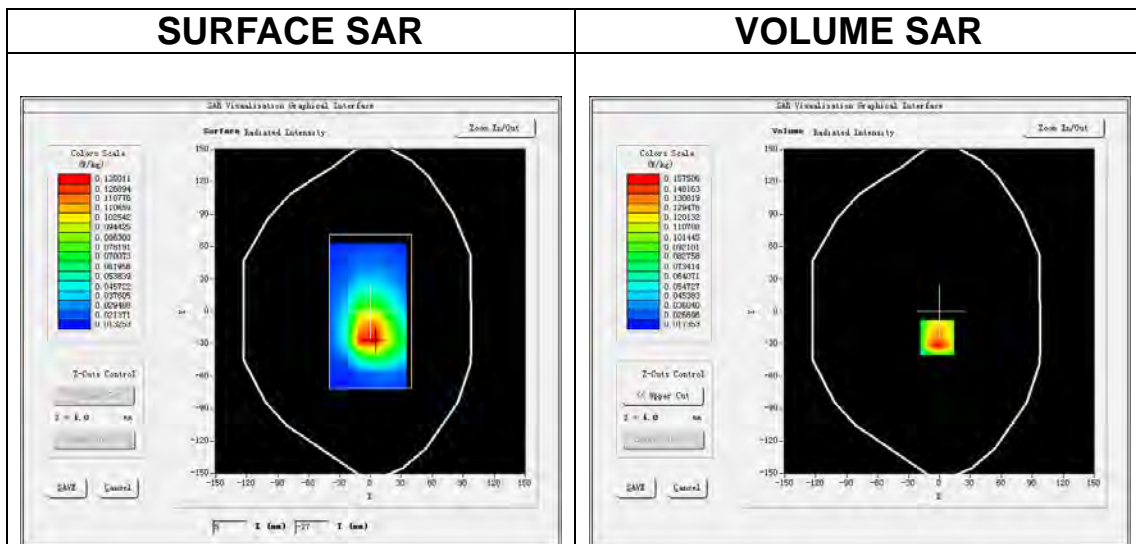

Maximum location: X=-2.00, Y=-24.00

SAR Peak: 0.26 W/kg

SAR 10g (W/Kg)	0.088459
SAR 1g (W/Kg)	0.152065

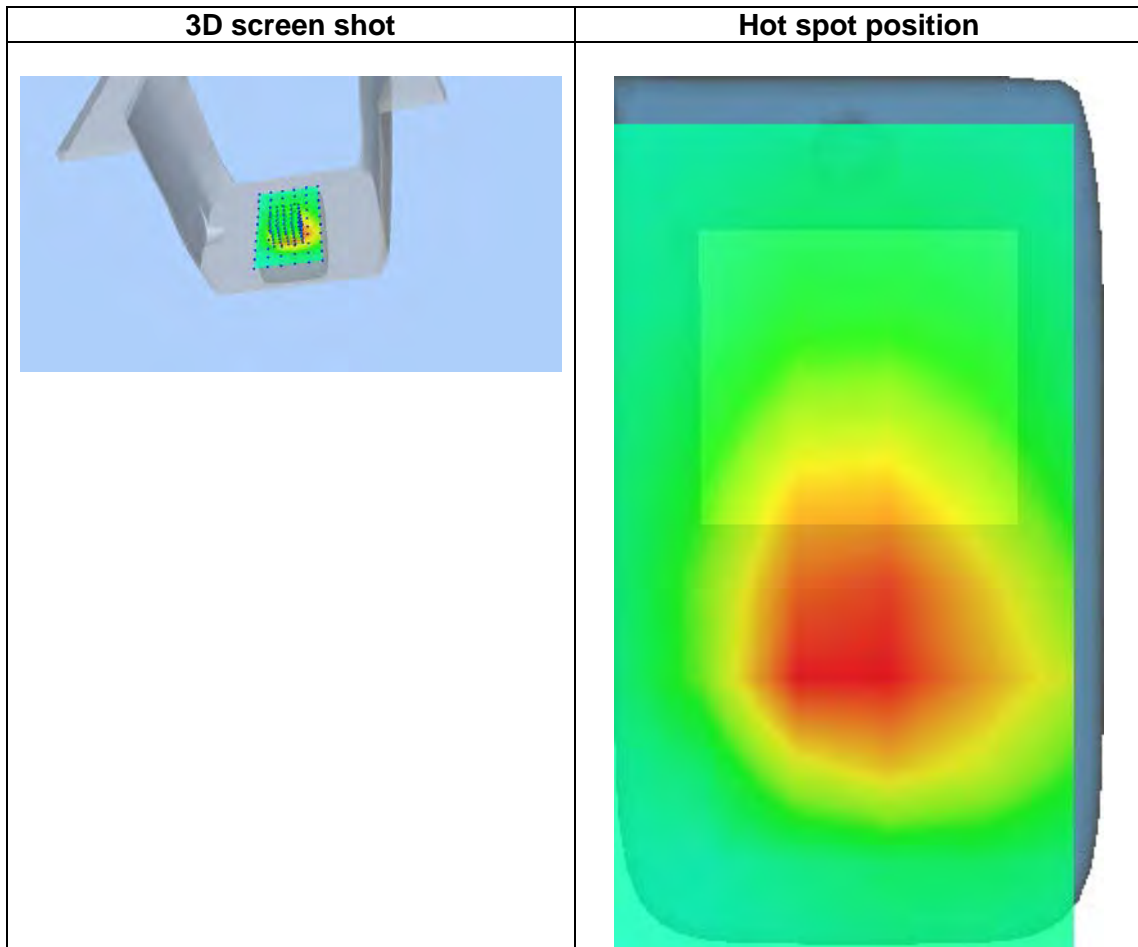
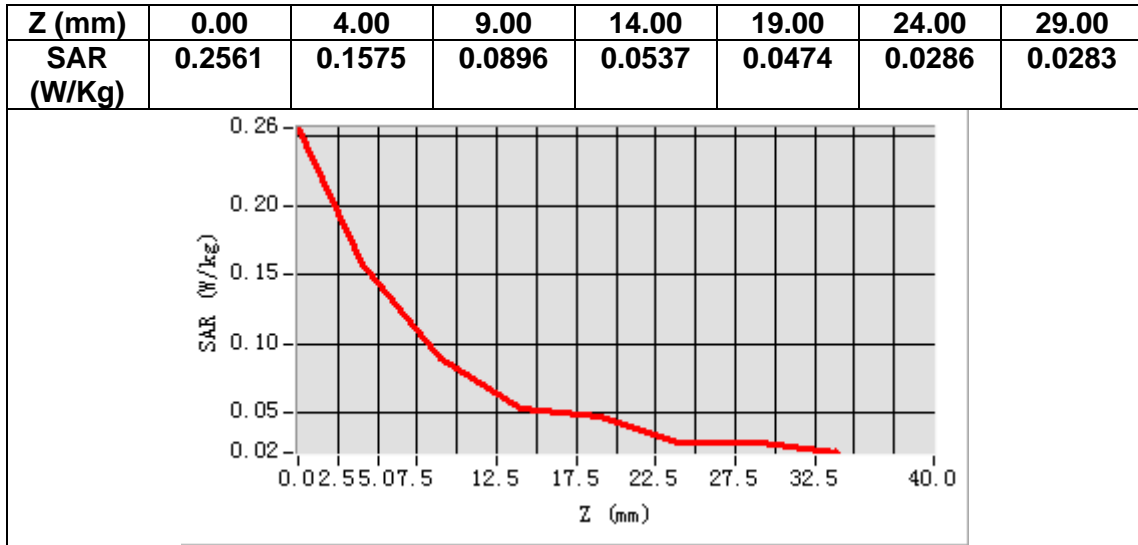

MEASUREMENT 5

A. Experimental conditions.

Area Scan	<u>dx=12mm dy=12mm, h= 5.00 mm</u>
ZoomScan	<u>7x7x7,dx=5mm dy=5mm dz=5mm</u>
Phantom	<u>Validation plane</u>
Device Position	<u>Body</u>
Band	<u>IEEE 802.11b ISM</u>
Channels	<u>Middle</u>
Signal	<u>IEEE802.11b (Crest factor: 1.0)</u>

B. SAR Measurement Results

Frequency (MHz)	2437.000000
Relative permittivity (real part)	51.623699
Relative permittivity (imaginary part)	13.924400
Conductivity (S/m)	1.885209
Variation (%)	-0.680000

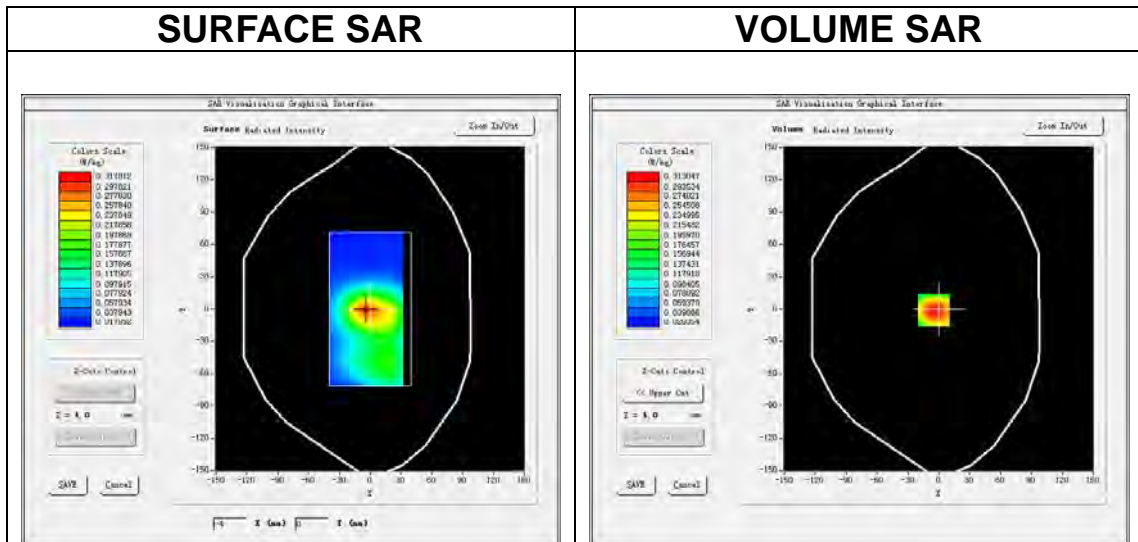

Maximum location: X=-5.00, Y=-1.00

SAR Peak: 0.47 W/kg

SAR 10g (W/Kg)	0.169728
SAR 1g (W/Kg)	0.295420

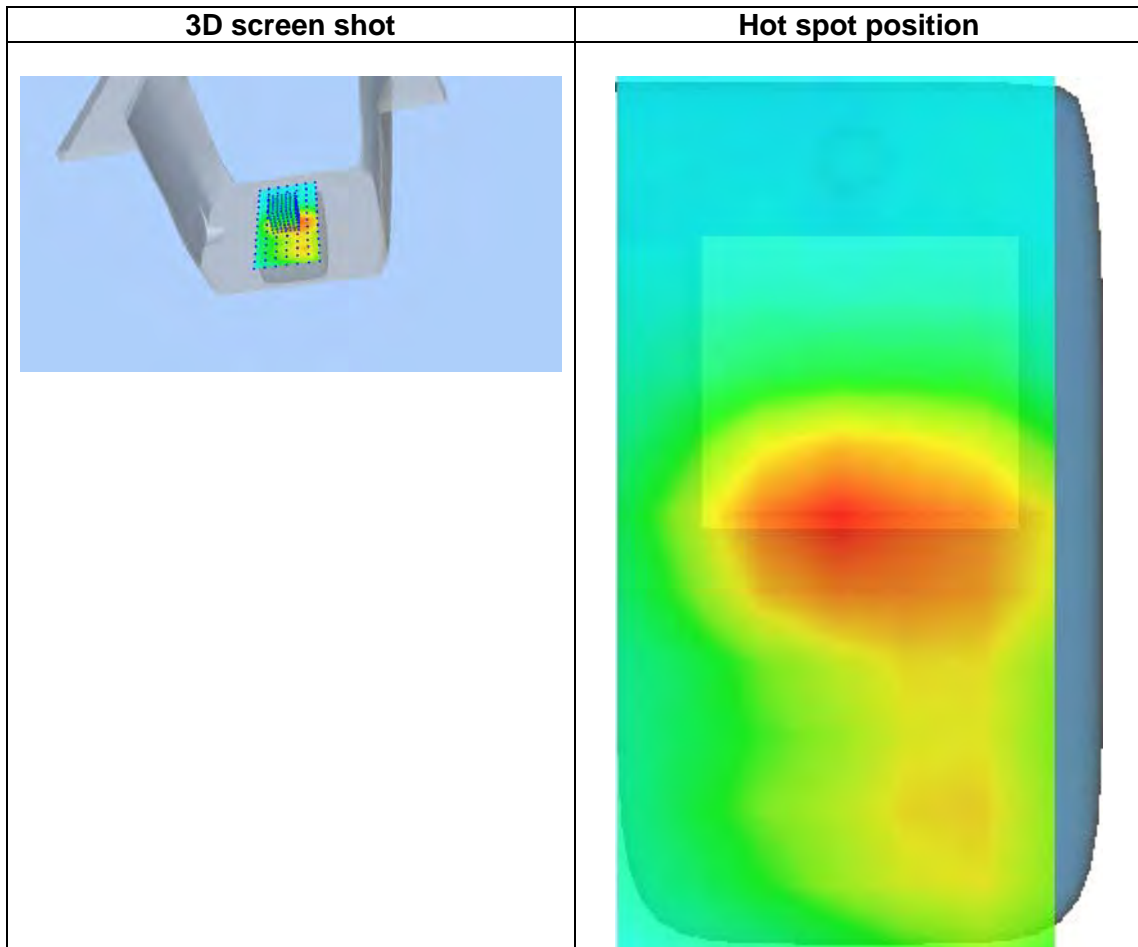
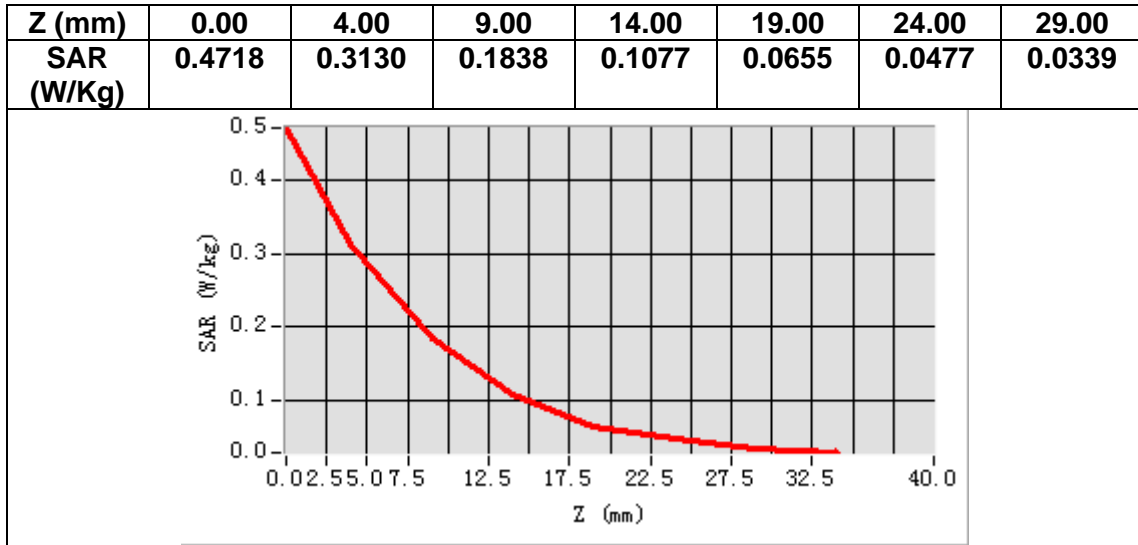

MEASUREMENT 6

A. Experimental conditions.

Area Scan	<u>dx=15mm dy=15mm, h= 5.00 mm</u>
ZoomScan	<u>5x5x7,dx=8mm dy=8mm dz=5mm</u>
Phantom	<u>Validation plane</u>
Device Position	<u>Body</u>
Band	<u>LTE band 2</u>
Channels	<u>Middle</u>
Signal	<u>LTE (Crest factor: 1.0)</u>

B. SAR Measurement Results

Frequency (MHz)	1880.000000
Relative permittivity (real part)	54.303902
Relative permittivity (imaginary part)	14.587700
Conductivity (S/m)	1.523604
Variation (%)	0.730000

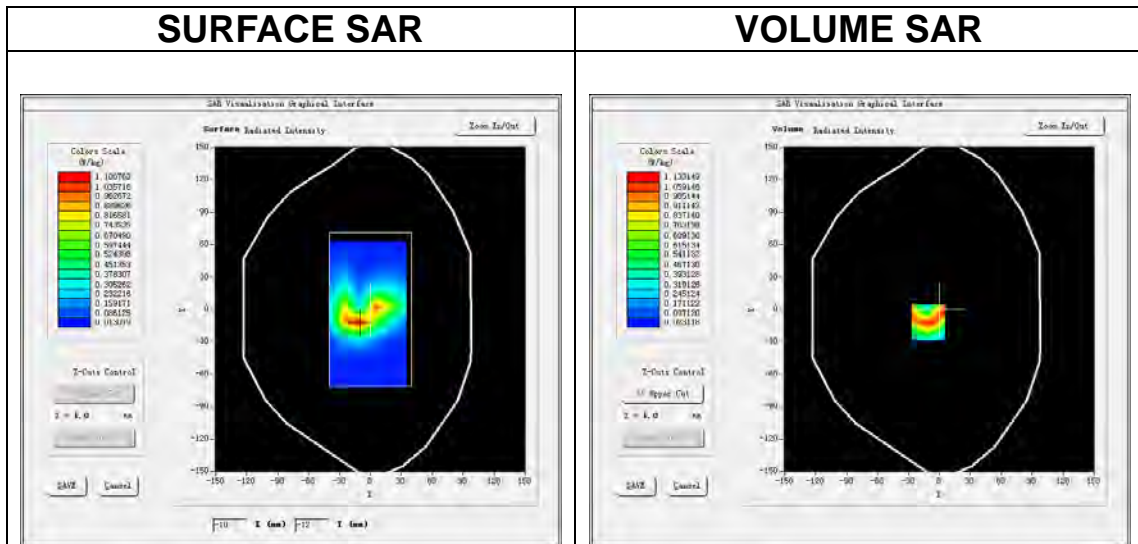

Maximum location: X=-11.00, Y=-12.00

SAR Peak: 2.04 W/kg

SAR 10g (W/Kg)	0.482836
SAR 1g (W/Kg)	1.045836

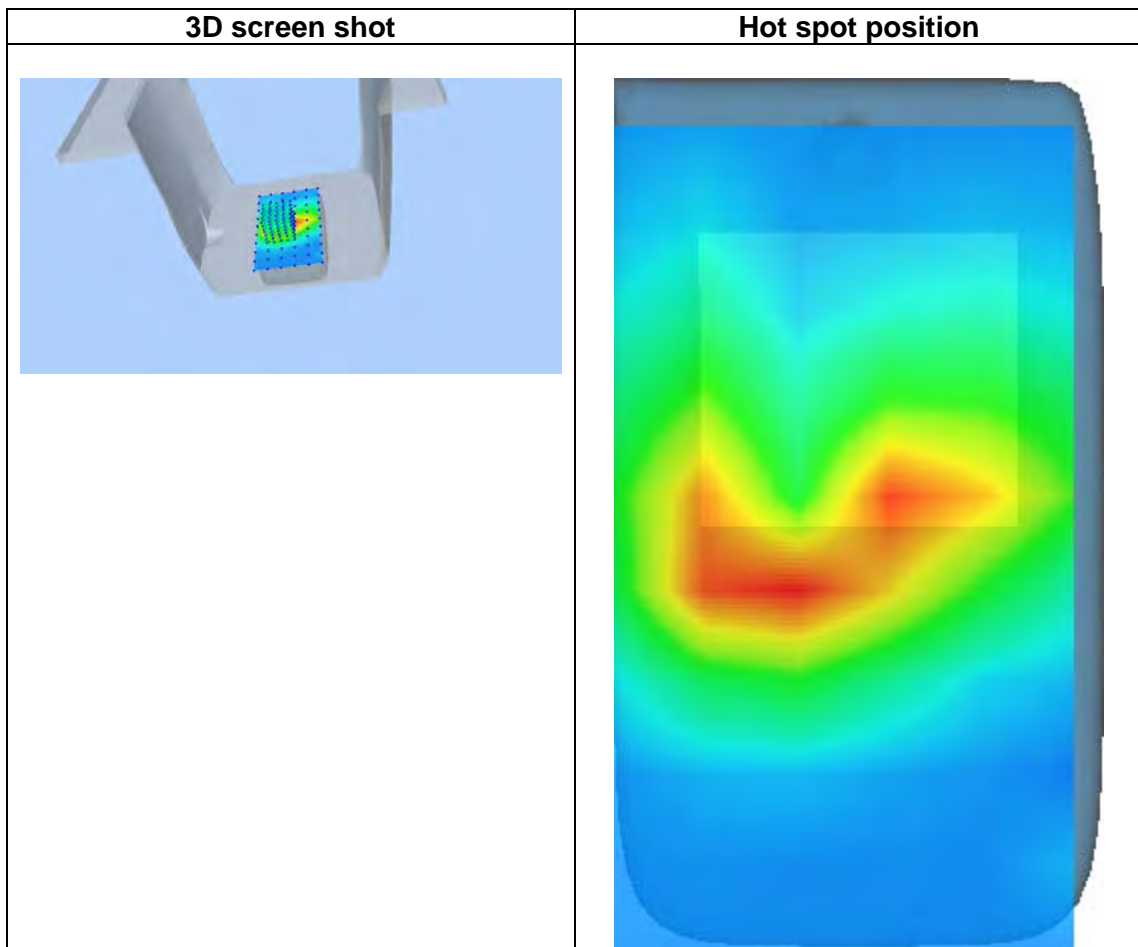
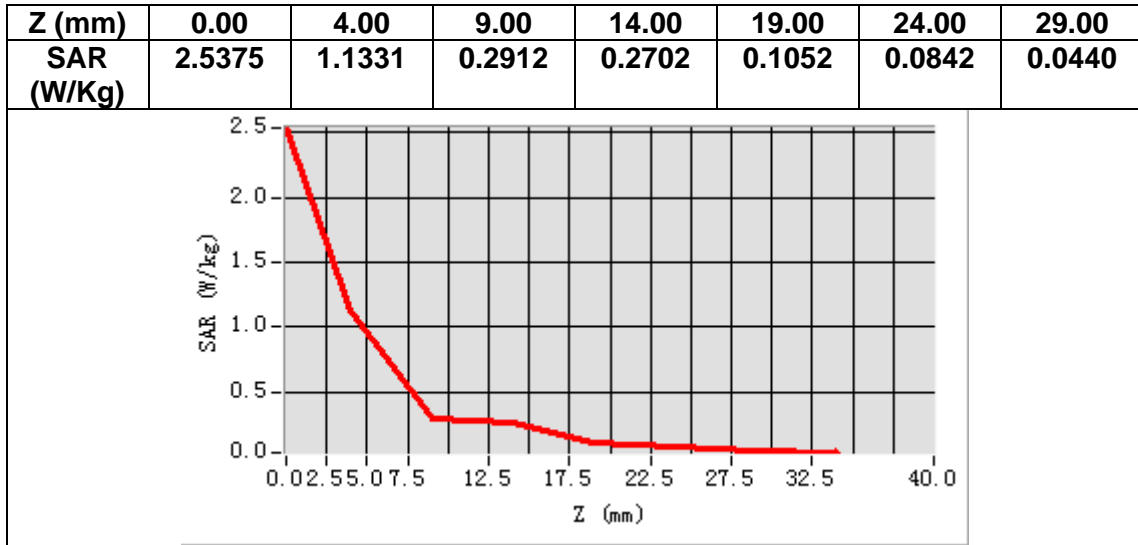

MEASUREMENT 7

A. Experimental conditions.

Area Scan	<u>dx=15mm dy=15mm, h= 5.00 mm</u>
ZoomScan	<u>5x5x7,dx=8mm dy=8mm dz=5mm</u>
Phantom	<u>Validation plane</u>
Device Position	<u>Body</u>
Band	<u>LTE band 5</u>
Channels	<u>Middle</u>
Signal	<u>LTE (Crest factor: 1.0)</u>

B. SAR Measurement Results

Frequency (MHz)	836.500000
Relative permittivity (real part)	54.503502
Relative permittivity (imaginary part)	21.177000
Conductivity (S/m)	0.984142
Variation (%)	0.100000

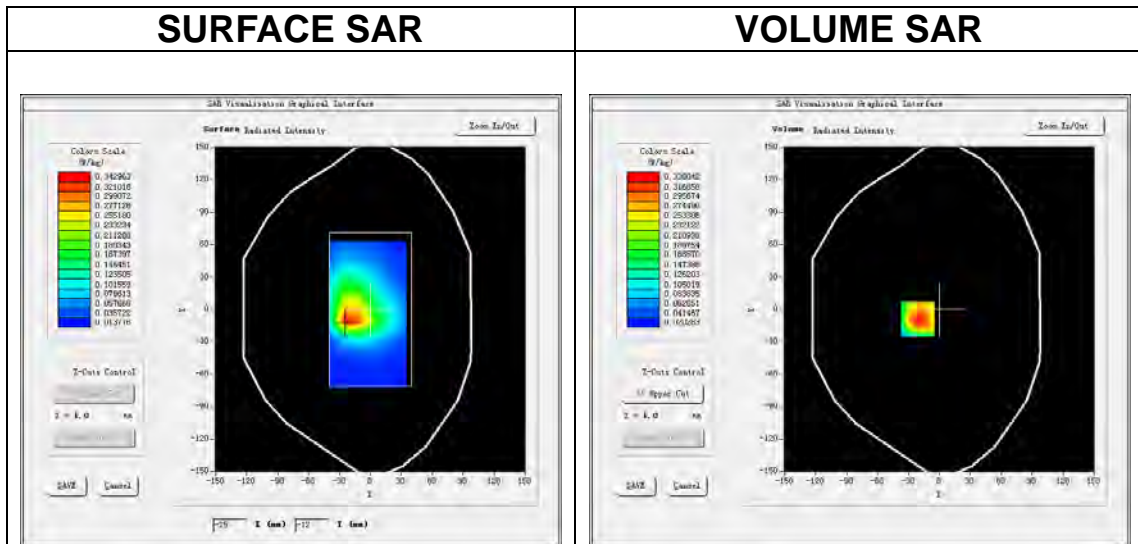

Maximum location: X=-21.00, Y=-9.00

SAR Peak: 0.57 W/kg

SAR 10g (W/Kg)	0.183098
SAR 1g (W/Kg)	0.332068

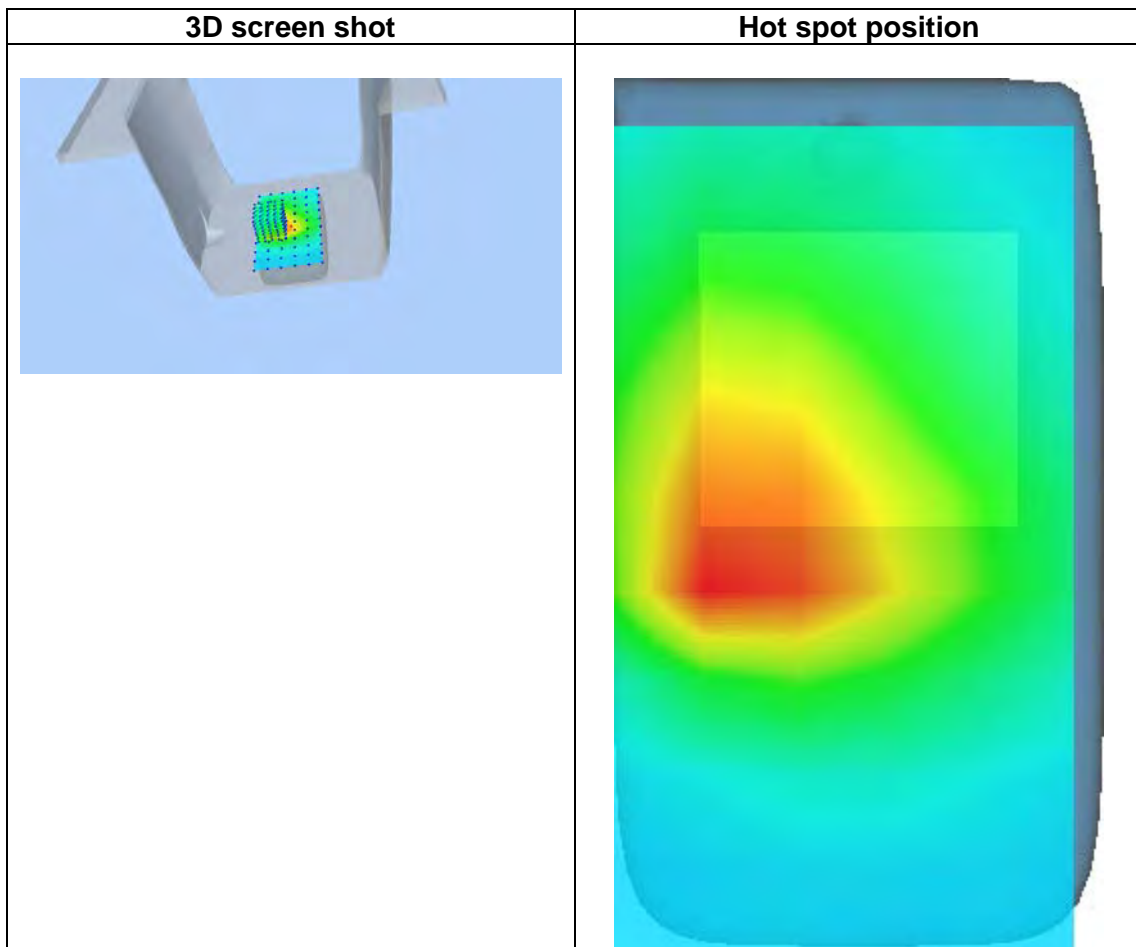
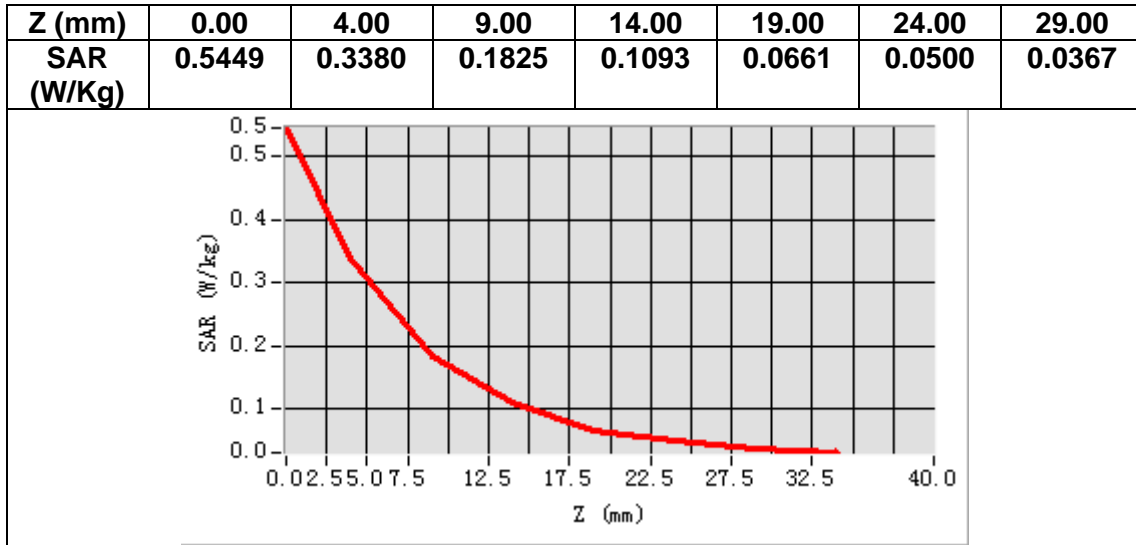

MEASUREMENT 8

A. Experimental conditions.

Area Scan	<u>dx=12mm dy=12mm, h= 5.00 mm</u>
ZoomScan	<u>7x7x7,dx=5mm dy=5mm dz=5mm</u>
Phantom	<u>Validation plane</u>
Device Position	<u>Body</u>
Band	<u>LTE band 7</u>
Channels	<u>Middle</u>
Signal	<u>LTE (Crest factor: 1.0)</u>

B. SAR Measurement Results

Frequency (MHz)	2535.000000
Relative permittivity (real part)	53.136948
Relative permittivity (imaginary part)	15.227840
Conductivity (S/m)	2.144587
Variation (%)	-0.190000

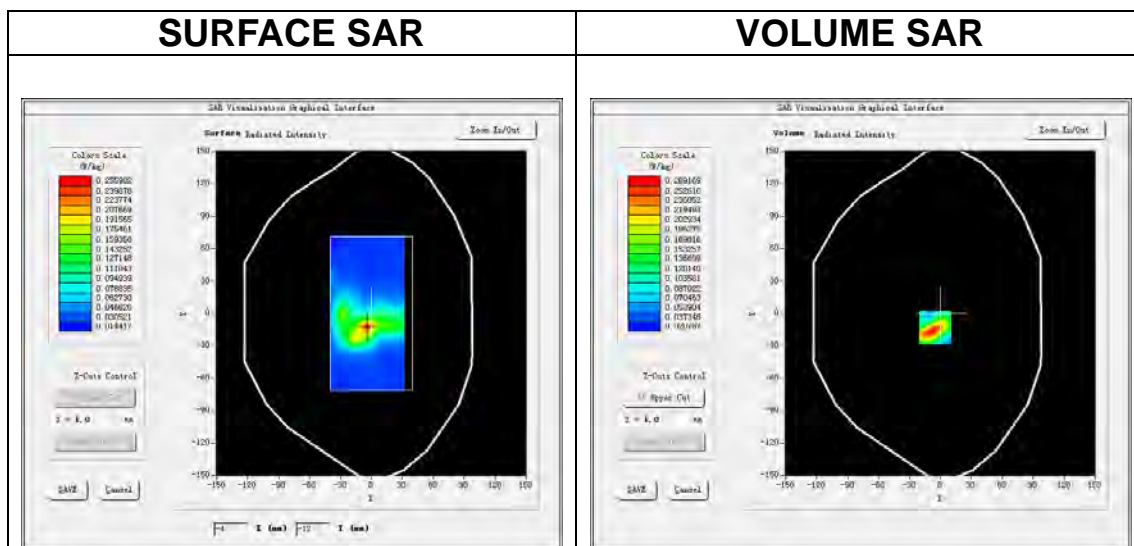

Maximum location: X=-5.00, Y=-13.00

SAR Peak: 0.50 W/kg

SAR 10g (W/Kg)	0.111858
SAR 1g (W/Kg)	0.250417

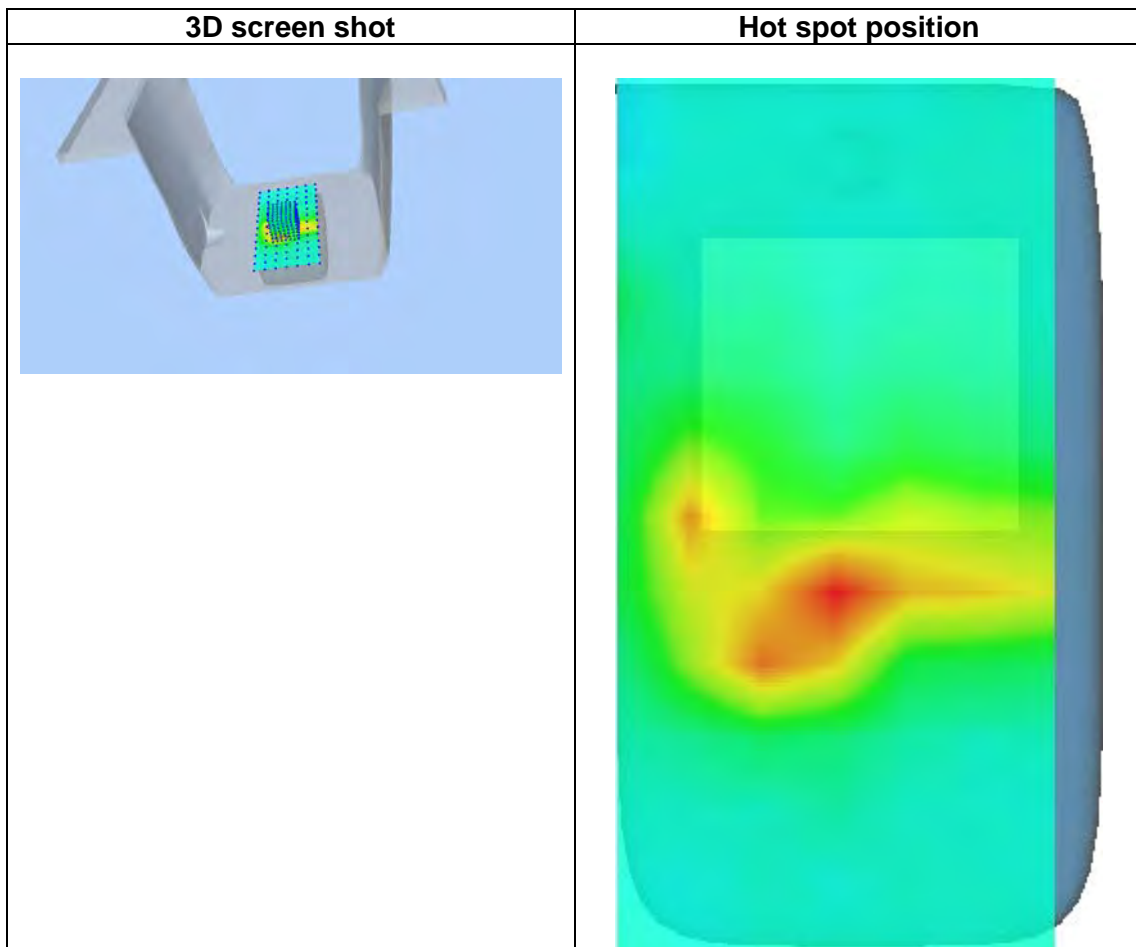
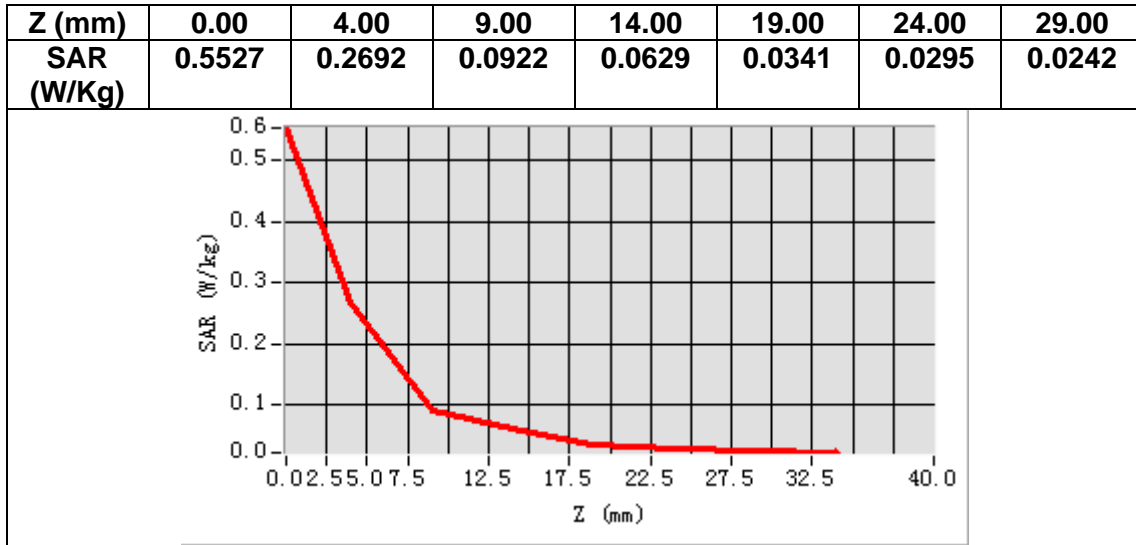

14. Appendix D. Calibration Certificate

Table of contents
E Field Probe - SN 08/16 EPGO287
835 MHz Dipole - SN 03/15 DIP 0G835-347
1900 MHz Dipole - SN 03/15 DIP 1G900-350
2450 MHz Dipole - SN 03/15 DIP 2G450-352
2600 MHz Dipole - SN 03/15 DIP 2G600-356



COMOSAR E-Field Probe Calibration Report

Ref : ACR.260.1.18.SATU.A

**SHENZHEN NTEK TESTING TECHNOLOGY
CO., LTD.**

**BUILDING E, FENDA SCIENCE PARK, SANWEI
COMMUNITY, XIXIANG STREET,
BAO'AN DISTRICT, SHENZHEN GUANGDONG, CHINA**

**MVG COMOSAR DOSIMETRIC E-FIELD PROBE
SERIAL NO.: SN 08/16 EPGO287**

**Calibrated at MVG US
2105 Barrett Park Dr. - Kennesaw, GA 30144**



Calibration Date: 12/27/2019

Summary:

This document presents the method and results from an accredited COMOSAR Dosimetric E-Field Probe calibration performed in MVG USA using the CALISAR / CALIBAIR test bench, for use with a COMOSAR system only. All calibration results are traceable to national metrology institutions.



COMOSAR E-FIELD PROBE CALIBRATION REPORT

Ref: ACR.260.1.18.SATU.A

	<i>Name</i>	<i>Function</i>	<i>Date</i>	<i>Signature</i>
<i>Prepared by :</i>	Jérôme LUC	Product Manager	12/27/2019	<i>JL</i>
<i>Checked by :</i>	Jérôme LUC	Product Manager	12/27/2019	<i>JL</i>
<i>Approved by :</i>	Kim RUTKOWSKI	Quality Manager	12/27/2019	<i>Kim Rutkowski</i>

	<i>Customer Name</i>
<i>Distribution :</i>	SHENZHEN NTEK TESTING TECHNOLOGY CO., LTD.

<i>Issue</i>	<i>Date</i>	<i>Modifications</i>
A	12/27/2019	Initial release



COMOSAR E-FIELD PROBE CALIBRATION REPORT

Ref: ACR.260.1.18.SATU.A

TABLE OF CONTENTS

1 Device Under Test 4

2 Product Description 4

 2.1 General Information 4

3 Measurement Method 4

 3.1 Linearity 4

 3.2 Sensitivity 5

 3.3 Lower Detection Limit 5

 3.4 Isotropy 5

 3.5 Boundary Effect 5

4 Measurement Uncertainty 5

5 Calibration Measurement Results 6

 5.1 Sensitivity in air 6

 5.2 Linearity 7

 5.3 Sensitivity in liquid 7

 5.4 Isotropy 8

6 List of Equipment 10



COMOSAR E-FIELD PROBE CALIBRATION REPORT

Ref: ACR.260.1.18.SATU.A

1 DEVICE UNDER TEST

Device Under Test	
Device Type	COMOSAR DOSIMETRIC E FIELD PROBE
Manufacturer	MVG
Model	SSE2
Serial Number	SN 08/16 EPGO287
Product Condition (new / used)	Used
Frequency Range of Probe	0.15 GHz-6GHz
Resistance of Three Dipoles at Connector	Dipole 1: R1=0.209 MΩ Dipole 2: R2=0.196 MΩ Dipole 3: R3=0.197 MΩ

A yearly calibration interval is recommended.

2 PRODUCT DESCRIPTION

2.1 GENERAL INFORMATION

MVG’s COMOSAR E field Probes are built in accordance to the IEEE 1528, OET 65 Bulletin C and CEI/IEC 62209 standards.



Figure 1 – MVG COMOSAR Dosimetric E field Dipole

Probe Length	330 mm
Length of Individual Dipoles	2 mm
Maximum external diameter	8 mm
Probe Tip External Diameter	2.5 mm
Distance between dipoles / probe extremity	1 mm

3 MEASUREMENT METHOD

The IEEE 1528, OET 65 Bulletin C, CENELEC EN50361 and CEI/IEC 62209 standards provide recommended practices for the probe calibrations, including the performance characteristics of interest and methods by which to assess their affect. All calibrations / measurements performed meet the fore mentioned standards.

3.1 LINEARITY

The evaluation of the linearity was done in free space using the waveguide, performing a power sweep to cover the SAR range 0.01W/kg to 100W/kg.



COMOSAR E-FIELD PROBE CALIBRATION REPORT

Ref: ACR.260.1.18.SATU.A

3.2 SENSITIVITY

The sensitivity factors of the three dipoles were determined using a two step calibration method (air and tissue simulating liquid) using waveguides as outlined in the standards.

3.3 LOWER DETECTION LIMIT

The lower detection limit was assessed using the same measurement set up as used for the linearity measurement. The required lower detection limit is 10 mW/kg.

3.4 ISOTROPY

The axial isotropy was evaluated by exposing the probe to a reference wave from a standard dipole with the dipole mounted under the flat phantom in the test configuration suggested for system validations and checks. The probe was rotated along its main axis from 0 - 360 degrees in 15 degree steps. The hemispherical isotropy is determined by inserting the probe in a thin plastic box filled with tissue-equivalent liquid, with the plastic box illuminated with the fields from a half wave dipole. The dipole is rotated about its axis (0°–180°) in 15° increments. At each step the probe is rotated about its axis (0°–360°).

3.5 BOUNDARY EFFECT

The boundary effect is defined as the deviation between the SAR measured data and the expected exponential decay in the liquid when the probe is oriented normal to the interface. To evaluate this effect, the liquid filled flat phantom is exposed to fields from either a reference dipole or waveguide. With the probe normal to the phantom surface, the peak spatial average SAR is measured and compared to the analytical value at the surface.

4 MEASUREMENT UNCERTAINTY

The guidelines outlined in the IEEE 1528, OET 65 Bulletin C, CENELEC EN50361 and CEI/IEC 62209 standards were followed to generate the measurement uncertainty associated with an E-field probe calibration using the waveguide technique. All uncertainties listed below represent an expanded uncertainty expressed at approximately the 95% confidence level using a coverage factor of k=2, traceable to the Internationally Accepted Guides to Measurement Uncertainty.

Uncertainty analysis of the probe calibration in waveguide					
ERROR SOURCES	Uncertainty value (%)	Probability Distribution	Divisor	ci	Standard Uncertainty (%)
Incident or forward power	3.00%	Rectangular	$\sqrt{3}$	1	1.732%
Reflected power	3.00%	Rectangular	$\sqrt{3}$	1	1.732%
Liquid conductivity	5.00%	Rectangular	$\sqrt{3}$	1	2.887%
Liquid permittivity	4.00%	Rectangular	$\sqrt{3}$	1	2.309%
Field homogeneity	3.00%	Rectangular	$\sqrt{3}$	1	1.732%
Field probe positioning	5.00%	Rectangular	$\sqrt{3}$	1	2.887%
Field probe linearity	3.00%	Rectangular	$\sqrt{3}$	1	1.732%
Combined standard uncertainty					5.831%
Expanded uncertainty 95 % confidence level k = 2					12.0%



COMOSAR E-FIELD PROBE CALIBRATION REPORT

Ref: ACR.260.1.18.SATU.A

5 CALIBRATION MEASUREMENT RESULTS

Calibration Parameters	
Liquid Temperature	21 °C
Lab Temperature	21 °C
Lab Humidity	45 %

5.1 SENSITIVITY IN AIR

Normx dipole 1 (μV/(V/m) ²)	Normy dipole 2 (μV/(V/m) ²)	Normz dipole 3 (μV/(V/m) ²)
0.66	0.75	0.58

DCP dipole 1 (mV)	DCP dipole 2 (mV)	DCP dipole 3 (mV)
93	93	98

Calibration curves $e_i=f(V)$ ($i=1,2,3$) allow to obtain H-field value using the formula:

$$E = \sqrt{E_1^2 + E_2^2 + E_3^2}$$

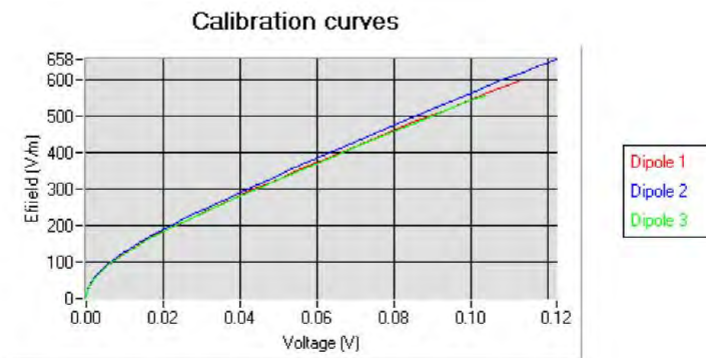



COMOSAR E-FIELD PROBE CALIBRATION REPORT

Ref: ACR.260.1.18.SATU.A

5.2 LINEARITY

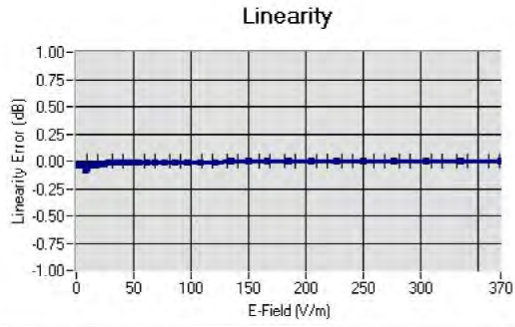

Linearity: $\pm 1.89\%$ ($\pm 0.08\text{dB}$)

5.3 SENSITIVITY IN LIQUID

Liquid	Frequency (MHz +/- 100MHz)	Permittivity	Epsilon (S/m)	ConvF
HL750	750	40.03	0.93	1.45
BL750	750	56.83	1.00	1.49
HL850	835	42.19	0.90	1.50
BL850	835	54.67	1.01	1.56
HL900	900	42.08	1.01	1.51
HL1800	1800	41.68	1.46	1.71
BL1800	1800	53.86	1.46	1.77
HL1900	1900	38.45	1.45	2.03
BL1900	1900	53.32	1.56	2.07
HL2000	2000	38.26	1.38	1.76
HL2450	2450	37.50	1.80	2.00
BL2450	2450	53.22	1.89	2.08
HL2600	2600	39.80	1.99	2.12
BL2600	2600	52.52	2.23	2.19
HL5200	5200	35.64	4.67	2.55
BL5200	5200	48.64	5.51	2.62
HL5400	5400	36.44	4.87	2.53
BL5400	5400	46.52	5.77	2.59
HL5600	5600	36.66	5.17	2.64
BL5600	5600	46.79	5.77	2.73
HL5800	5800	35.31	5.31	2.72
BL5800	5800	47.04	6.10	2.81

LOWER DETECTION LIMIT: 7mW/kg



COMOSAR E-FIELD PROBE CALIBRATION REPORT

Ref: ACR.260.1.18.SATU.A

5.4 ISOTROPY

HL900 MHz

- Axial isotropy: 0.04 dB
- Hemispherical isotropy: 0.07 dB

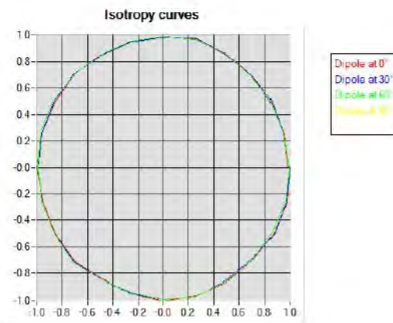

HL1800 MHz

- Axial isotropy: 0.06 dB
- Hemispherical isotropy: 0.08 dB

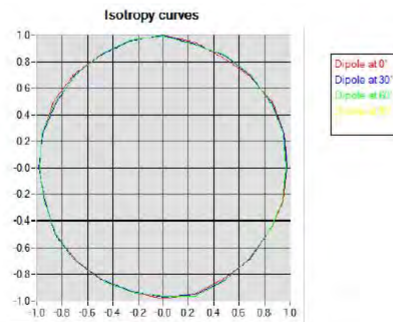



COMOSAR E-FIELD PROBE CALIBRATION REPORT

Ref: ACR.260.1.18.SATU.A

HL5600 MHz

- Axial isotropy: 0.06 dB
- Hemispherical isotropy: 0.08 dB

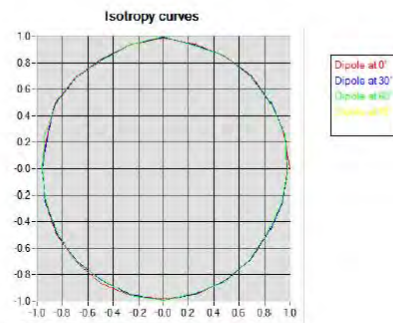



COMOSAR E-FIELD PROBE CALIBRATION REPORT

Ref: ACR.260.1.18.SATU.A

6 LIST OF EQUIPMENT

Equipment Summary Sheet				
Equipment Description	Manufacturer / Model	Identification No.	Current Calibration Date	Next Calibration Date
Flat Phantom	MVG	SN-20/09-SAM71	Validated. No cal required.	Validated. No cal required.
COMOSAR Test Bench	Version 3	NA	Validated. No cal required.	Validated. No cal required.
Network Analyzer	Rhode & Schwarz ZVA	SN100132	02/2019	02/2022
Reference Probe	MVG	EP 94 SN 37/08	10/2019	10/2020
Multimeter	Keithley 2000	1188656	01/2017	01/2020
Signal Generator	Agilent E4438C	MY49070581	01/2017	01/2020
Amplifier	Aethercomm	SN 046	Characterized prior to test. No cal required.	Characterized prior to test. No cal required.
Power Meter	HP E4418A	US38261498	01/2017	01/2020
Power Sensor	HP ECP-E26A	US37181460	01/2017	01/2020
Directional Coupler	Narda 4216-20	01386	Characterized prior to test. No cal required.	Characterized prior to test. No cal required.
Waveguide	Mega Industries	069Y7-158-13-712	Validated. No cal required.	Validated. No cal required.
Waveguide Transition	Mega Industries	069Y7-158-13-701	Validated. No cal required.	Validated. No cal required.
Waveguide Termination	Mega Industries	069Y7-158-13-701	Validated. No cal required.	Validated. No cal required.
Temperature / Humidity Sensor	Control Company	150798832	11/2017	11/2020



SAR Reference Dipole Calibration Report

Ref : ACR.109.2.18.SATU.A

**SHENZHEN NTEK TESTING TECHNOLOGY
CO., LTD.**

**BUILDING E, FENDA SCIENCE PARK, SANWEI
COMMUNITY, XIXIANG STREET,
BAO'AN DISTRICT, SHENZHEN GUANGDONG, CHINA**

MVG COMOSAR REFERENCE DIPOLE

FREQUENCY: 835 MHZ

SERIAL NO.: SN 03/15 DIP 0G835-347

Calibrated at MVG US

2105 Barrett Park Dr. - Kennesaw, GA 30144



Calibration Date: 04/19/2018

Summary:

This document presents the method and results from an accredited SAR reference dipole calibration performed in MVG USA using the COMOSAR test bench. All calibration results are traceable to national metrology institutions.



SAR REFERENCE DIPOLE CALIBRATION REPORT

Ref: ACR.109.2.18.SATU.A

	<i>Name</i>	<i>Function</i>	<i>Date</i>	<i>Signature</i>
<i>Prepared by :</i>	Jérôme LUC	Product Manager	4/19/2018	<i>JL</i>
<i>Checked by :</i>	Jérôme LUC	Product Manager	4/19/2018	<i>JL</i>
<i>Approved by :</i>	Kim RUTKOWSKI	Quality Manager	4/19/2018	<i>Kim Rutkowski</i>

	<i>Customer Name</i>
<i>Distribution :</i>	SHENZHEN NTEK TESTING TECHNOLOGY CO., LTD.

<i>Issue</i>	<i>Date</i>	<i>Modifications</i>
A	4/19/2018	Initial release



SAR REFERENCE DIPOLE CALIBRATION REPORT

Ref: ACR.109.2.18.SATU.A

TABLE OF CONTENTS

1 Introduction 4

2 Device Under Test 4

3 Product Description 4

 3.1 General Information 4

4 Measurement Method 5

 4.1 Return Loss Requirements 5

 4.2 Mechanical Requirements 5

5 Measurement Uncertainty 5

 5.1 Return Loss 5

 5.2 Dimension Measurement 5

 5.3 Validation Measurement 5

6 Calibration Measurement Results 6

 6.1 Return Loss and Impedance In Head Liquid 6

 6.2 Return Loss and Impedance In Body Liquid 6

 6.3 Mechanical Dimensions 6

7 Validation measurement 7

 7.1 Head Liquid Measurement 7

 7.2 SAR Measurement Result With Head Liquid 8

 7.3 Body Liquid Measurement 9

 7.4 SAR Measurement Result With Body Liquid 10

8 List of Equipment 11



SAR REFERENCE DIPOLE CALIBRATION REPORT

Ref: ACR.109.2.18.SATU.A

1 INTRODUCTION

This document contains a summary of the requirements set forth by the IEEE 1528, FCC KDBs and CEI/IEC 62209 standards for reference dipoles used for SAR measurement system validations and the measurements that were performed to verify that the product complies with the fore mentioned standards.

2 DEVICE UNDER TEST

Device Under Test	
Device Type	COMOSAR 835 MHz REFERENCE DIPOLE
Manufacturer	MVG
Model	SID835
Serial Number	SN 03/15 DIP 0G835-347
Product Condition (new / used)	Used

A yearly calibration interval is recommended.

3 PRODUCT DESCRIPTION

3.1 GENERAL INFORMATION

MVG’s COMOSAR Validation Dipoles are built in accordance to the IEEE 1528, FCC KDBs and CEI/IEC 62209 standards. The product is designed for use with the COMOSAR test bench only.



Figure 1 – MVG COMOSAR Validation Dipole



SAR REFERENCE DIPOLE CALIBRATION REPORT

Ref: ACR.109.2.18.SATU.A

4 MEASUREMENT METHOD

The IEEE 1528, FCC KDBs and CEI/IEC 62209 standards provide requirements for reference dipoles used for system validation measurements. The following measurements were performed to verify that the product complies with the fore mentioned standards.

4.1 RETURN LOSS REQUIREMENTS

The dipole used for SAR system validation measurements and checks must have a return loss of -20 dB or better. The return loss measurement shall be performed against a liquid filled flat phantom, with the phantom constructed as outlined in the fore mentioned standards.

4.2 MECHANICAL REQUIREMENTS

The IEEE Std. 1528 and CEI/IEC 62209 standards specify the mechanical components and dimensions of the validation dipoles, with the dimensions frequency and phantom shell thickness dependent. The COMOSAR test bench employs a 2 mm phantom shell thickness therefore the dipoles sold for use with the COMOSAR test bench comply with the requirements set forth for a 2 mm phantom shell thickness.

5 MEASUREMENT UNCERTAINTY

All uncertainties listed below represent an expanded uncertainty expressed at approximately the 95% confidence level using a coverage factor of k=2, traceable to the Internationally Accepted Guides to Measurement Uncertainty.

5.1 RETURN LOSS

The following uncertainties apply to the return loss measurement:

Frequency band	Expanded Uncertainty on Return Loss
400-6000MHz	0.1 dB

5.2 DIMENSION MEASUREMENT

The following uncertainties apply to the dimension measurements:

Length (mm)	Expanded Uncertainty on Length
3 - 300	0.05 mm

5.3 VALIDATION MEASUREMENT

The guidelines outlined in the IEEE 1528, FCC KDBs, CENELEC EN50361 and CEI/IEC 62209 standards were followed to generate the measurement uncertainty for validation measurements.

Scan Volume	Expanded Uncertainty
1 g	20.3 %



SAR REFERENCE DIPOLE CALIBRATION REPORT

Ref: ACR.109.2.18.SATU.A

10 g	20.1 %
------	--------

6 CALIBRATION MEASUREMENT RESULTS

6.1 RETURN LOSS AND IMPEDANCE IN HEAD LIQUID

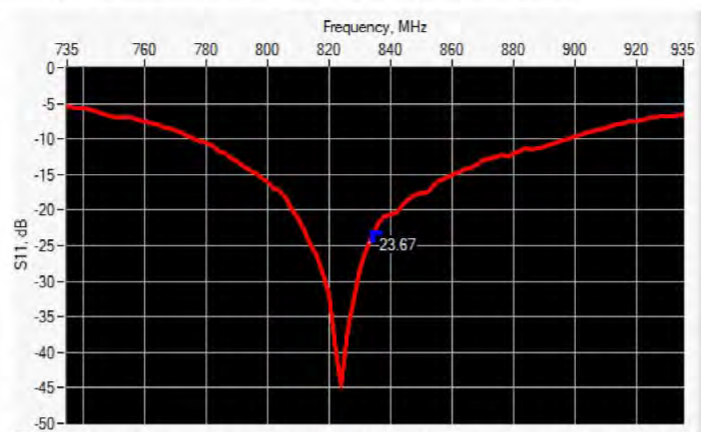

Frequency (MHz)	Return Loss (dB)	Requirement (dB)	Impedance
835	-23.67	-20	56.8 Ω - 1.5 jΩ

6.2 RETURN LOSS AND IMPEDANCE IN BODY LIQUID

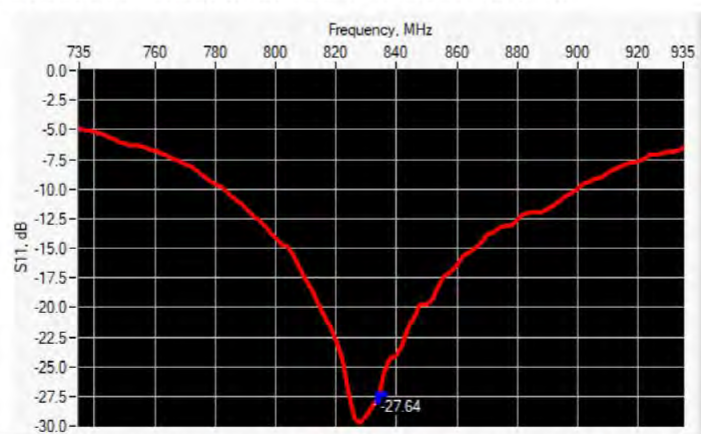

Frequency (MHz)	Return Loss (dB)	Requirement (dB)	Impedance
835	-27.64	-20	53.5 Ω + 2.3 jΩ

6.3 MECHANICAL DIMENSIONS

Frequency MHz	L mm		h mm		d mm	
	required	measured	required	measured	required	measured
300	420.0 ±1 %.		250.0 ±1 %.		6.35 ±1 %.	



SAR REFERENCE DIPOLE CALIBRATION REPORT

Ref: ACR.109.2.18.SATU.A

450	290.0 ±1 %.		166.7 ±1 %.		6.35 ±1 %.	
750	176.0 ±1 %.		100.0 ±1 %.		6.35 ±1 %.	
835	161.0 ±1 %.	PASS	89.8 ±1 %.	PASS	3.6 ±1 %.	PASS
900	149.0 ±1 %.		83.3 ±1 %.		3.6 ±1 %.	
1450	89.1 ±1 %.		51.7 ±1 %.		3.6 ±1 %.	
1500	80.5 ±1 %.		50.0 ±1 %.		3.6 ±1 %.	
1640	79.0 ±1 %.		45.7 ±1 %.		3.6 ±1 %.	
1750	75.2 ±1 %.		42.9 ±1 %.		3.6 ±1 %.	
1800	72.0 ±1 %.		41.7 ±1 %.		3.6 ±1 %.	
1900	68.0 ±1 %.		39.5 ±1 %.		3.6 ±1 %.	
1950	66.3 ±1 %.		38.5 ±1 %.		3.6 ±1 %.	
2000	64.5 ±1 %.		37.5 ±1 %.		3.6 ±1 %.	
2100	61.0 ±1 %.		35.7 ±1 %.		3.6 ±1 %.	
2300	55.5 ±1 %.		32.6 ±1 %.		3.6 ±1 %.	
2450	51.5 ±1 %.		30.4 ±1 %.		3.6 ±1 %.	
2600	48.5 ±1 %.		28.8 ±1 %.		3.6 ±1 %.	
3000	41.5 ±1 %.		25.0 ±1 %.		3.6 ±1 %.	
3500	37.0 ±1 %.		26.4 ±1 %.		3.6 ±1 %.	
3700	34.7 ±1 %.		26.4 ±1 %.		3.6 ±1 %.	

7 VALIDATION MEASUREMENT

The IEEE Std. 1528, FCC KDBs and CEI/IEC 62209 standards state that the system validation measurements must be performed using a reference dipole meeting the fore mentioned return loss and mechanical dimension requirements. The validation measurement must be performed against a liquid filled flat phantom, with the phantom constructed as outlined in the fore mentioned standards. Per the standards, the dipole shall be positioned below the bottom of the phantom, with the dipole length centered and parallel to the longest dimension of the flat phantom, with the top surface of the dipole at the described distance from the bottom surface of the phantom.

7.1 HEAD LIQUID MEASUREMENT

Frequency MHz	Relative permittivity (ε _r)		Conductivity (σ) S/m	
	required	measured	required	measured
300	45.3 ±5 %		0.87 ±5 %	
450	43.5 ±5 %		0.87 ±5 %	
750	41.9 ±5 %		0.89 ±5 %	
835	41.5 ±5 %	PASS	0.90 ±5 %	PASS
900	41.5 ±5 %		0.97 ±5 %	
1450	40.5 ±5 %		1.20 ±5 %	
1500	40.4 ±5 %		1.23 ±5 %	
1640	40.2 ±5 %		1.31 ±5 %	
1750	40.1 ±5 %		1.37 ±5 %	



SAR REFERENCE DIPOLE CALIBRATION REPORT

Ref: ACR.109.2.18.SATU.A

1800	40.0 ±5 %		1.40 ±5 %	
1900	40.0 ±5 %		1.40 ±5 %	
1950	40.0 ±5 %		1.40 ±5 %	
2000	40.0 ±5 %		1.40 ±5 %	
2100	39.8 ±5 %		1.49 ±5 %	
2300	39.5 ±5 %		1.67 ±5 %	
2450	39.2 ±5 %		1.80 ±5 %	
2600	39.0 ±5 %		1.96 ±5 %	
3000	38.5 ±5 %		2.40 ±5 %	
3500	37.9 ±5 %		2.91 ±5 %	

7.2 SAR MEASUREMENT RESULT WITH HEAD LIQUID

The IEEE Std. 1528 and CEI/IEC 62209 standards state that the system validation measurements should produce the SAR values shown below (for phantom thickness of 2 mm), within the uncertainty for the system validation. All SAR values are normalized to 1 W forward power. In bracket, the measured SAR is given with the used input power.

Software	OPENSAR V4
Phantom	SN 20/09 SAM71
Probe	SN 18/11 EPG122
Liquid	Head Liquid Values: eps' : 40.0 sigma : 0.90
Distance between dipole center and liquid	15.0 mm
Area scan resolution	dx=8mm/dy=8mm
Zoon Scan Resolution	dx=8mm/dy=8mm/dz=5mm
Frequency	835 MHz
Input power	20 dBm
Liquid Temperature	21 °C
Lab Temperature	21 °C
Lab Humidity	45 %

Frequency MHz	1 g SAR (W/kg/W)		10 g SAR (W/kg/W)	
	required	measured	required	measured
300	2.85		1.94	
450	4.58		3.06	
750	8.49		5.55	
835	9.56	9.55 (0.95)	6.22	6.10 (0.61)
900	10.9		6.99	
1450	29		16	
1500	30.5		16.8	
1640	34.2		18.4	
1750	36.4		19.3	
1800	38.4		20.1	



SAR REFERENCE DIPOLE CALIBRATION REPORT

Ref: ACR.109.2.18.SATU.A

1900	39.7		20.5	
1950	40.5		20.9	
2000	41.1		21.1	
2100	43.6		21.9	
2300	48.7		23.3	
2450	52.4		24	
2600	55.3		24.6	
3000	63.8		25.7	
3500	67.1		25	
3700	67.4		24.2	

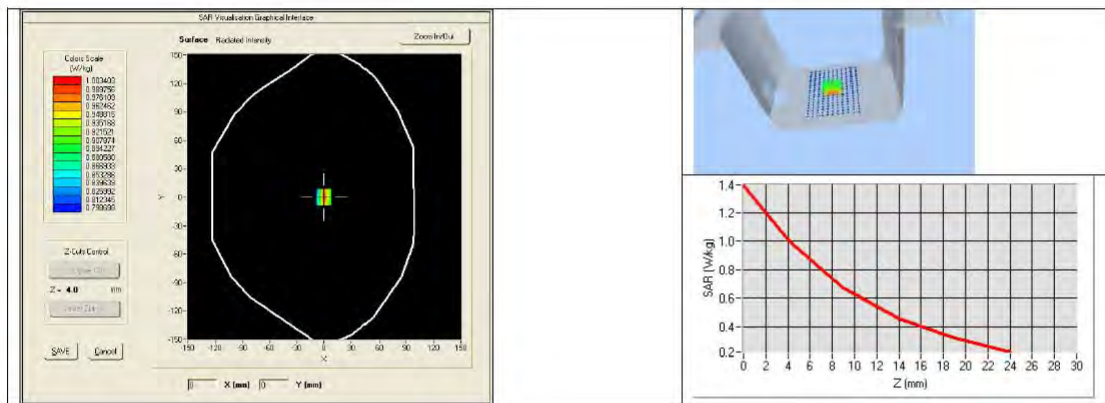

7.3 BODY LIQUID MEASUREMENT

Frequency MHz	Relative permittivity (ϵ_r')		Conductivity (σ) S/m	
	required	measured	required	measured
150	61.9 ±5 %		0.80 ±5 %	
300	58.2 ±5 %		0.92 ±5 %	
450	56.7 ±5 %		0.94 ±5 %	
750	55.5 ±5 %		0.96 ±5 %	
835	55.2 ±5 %	PASS	0.97 ±5 %	PASS
900	55.0 ±5 %		1.05 ±5 %	
915	55.0 ±5 %		1.06 ±5 %	
1450	54.0 ±5 %		1.30 ±5 %	
1610	53.8 ±5 %		1.40 ±5 %	
1800	53.3 ±5 %		1.52 ±5 %	
1900	53.3 ±5 %		1.52 ±5 %	
2000	53.3 ±5 %		1.52 ±5 %	
2100	53.2 ±5 %		1.62 ±5 %	

Page: 9/11

This document shall not be reproduced, except in full or in part, without the written approval of MVG. The information contained herein is to be used only for the purpose for which it is submitted and is not to be released in whole or part without written approval of MVG.



SAR REFERENCE DIPOLE CALIBRATION REPORT

Ref: ACR.109.2.18.SATU.A

2300	52.9 ±5 %		1.81 ±5 %
2450	52.7 ±5 %		1.95 ±5 %
2600	52.5 ±5 %		2.16 ±5 %
3000	52.0 ±5 %		2.73 ±5 %
3500	51.3 ±5 %		3.31 ±5 %
3700	51.0 ±5 %		3.55 ±5 %
5200	49.0 ±10 %		5.30 ±10 %
5300	48.9 ±10 %		5.42 ±10 %
5400	48.7 ±10 %		5.53 ±10 %
5500	48.6 ±10 %		5.65 ±10 %
5600	48.5 ±10 %		5.77 ±10 %
5800	48.2 ±10 %		6.00 ±10 %

7.4 SAR MEASUREMENT RESULT WITH BODY LIQUID

Software	OPENSAR V4
Phantom	SN 20/09 SAM71
Probe	SN 18/11 EPG122
Liquid	Body Liquid Values: eps' : 57.5 sigma : 0.96
Distance between dipole center and liquid	15.0 mm
Area scan resolution	dx=8mm/dy=8mm
Zoon Scan Resolution	dx=8mm/dy=8mm/dz=5mm
Frequency	835 MHz
Input power	20 dBm
Liquid Temperature	21 °C
Lab Temperature	21 °C
Lab Humidity	45 %

Frequency MHz	1 g SAR (W/kg/W)	10 g SAR (W/kg/W)
	measured	measured
835	9.83 (0.98)	6.45 (0.64)

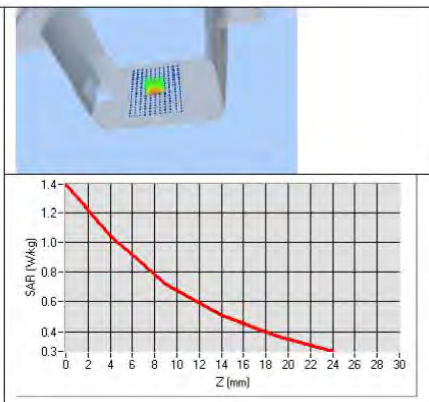
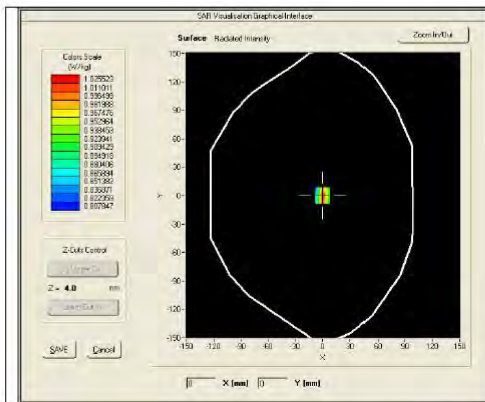



SAR REFERENCE DIPOLE CALIBRATION REPORT

Ref: ACR.109.2.18.SATU.A

8 LIST OF EQUIPMENT

Equipment Summary Sheet				
Equipment Description	Manufacturer / Model	Identification No.	Current Calibration Date	Next Calibration Date
SAM Phantom	MVG	SN-20/09-SAM71	Validated. No cal required.	Validated. No cal required.
COMOSAR Test Bench	Version 3	NA	Validated. No cal required.	Validated. No cal required.
Network Analyzer	Rhode & Schwarz ZVA	SN100132	02/2016	02/2019
Calipers	Carrera	CALIPER-01	01/2017	01/2020
Reference Probe	MVG	EPG122 SN 18/11	10/2017	10/2018
Multimeter	Keithley 2000	1188656	01/2017	01/2020
Signal Generator	Agilent E4438C	MY49070581	01/2017	01/2020
Amplifier	Aethercomm	SN 046	Characterized prior to test. No cal required.	Characterized prior to test. No cal required.
Power Meter	HP E4418A	US38261498	01/2017	01/2020
Power Sensor	HP ECP-E26A	US37181460	01/2017	01/2020
Directional Coupler	Narda 4216-20	01386	Characterized prior to test. No cal required.	Characterized prior to test. No cal required.
Temperature and Humidity Sensor	Control Company	150798832	11/2017	11/2020



SAR Reference Dipole Calibration Report

Ref : ACR.109.5.18.SATU.A

**SHENZHEN NTEK TESTING TECHNOLOGY
CO., LTD.**

**BUILDING E, FENDA SCIENCE PARK, SANWEI
COMMUNITY, XIXIANG STREET,
BAO'AN DISTRICT, SHENZHEN GUANGDONG, CHINA**

MVG COMOSAR REFERENCE DIPOLE

FREQUENCY: 1900 MHZ

SERIAL NO.: SN 03/15 DIP 1G900-350

Calibrated at MVG US

2105 Barrett Park Dr. - Kennesaw, GA 30144



Calibration Date: 04/19/2018

Summary:

This document presents the method and results from an accredited SAR reference dipole calibration performed in MVG USA using the COMOSAR test bench. All calibration results are traceable to national metrology institutions.



SAR REFERENCE DIPOLE CALIBRATION REPORT

Ref: ACR.109.5.18.SATU.A

	<i>Name</i>	<i>Function</i>	<i>Date</i>	<i>Signature</i>
<i>Prepared by :</i>	Jérôme LUC	Product Manager	4/19/2018	<i>JS</i>
<i>Checked by :</i>	Jérôme LUC	Product Manager	4/19/2018	<i>JS</i>
<i>Approved by :</i>	Kim RUTKOWSKI	Quality Manager	4/19/2018	<i>Kim Rutkowski</i>

	<i>Customer Name</i>
<i>Distribution :</i>	SHENZHEN NTEK TESTING TECHNOLOGY CO., LTD.

<i>Issue</i>	<i>Date</i>	<i>Modifications</i>
A	4/19/2018	Initial release