

FCC Radio Test Report

FCC ID: 2AKMD-S921

Original Grant

Report No. : TB-FCC151149
Applicant : ShenZhen Megastek Electronics Co. Ltd.
Equipment Under Test (EUT)
EUT Name : Home base unit
Model No. : S921
Series No. : MT200-HBU, MT200XF
Brand Name : N/A
Receipt Date : 2016-12-24
Test Date : 2016-12-25 to 2017-03-13
Issue Date : 2017-03-14
Standards : FCC Part 2
FCC Part 22 Subpart H, FCC Part 24 Subpart E, 2015
ANSI/TIAC63.26: 2015
Conclusions : **PASS**
In the configuration tested, the EUT complied with the standards specified above,
The EUT technically complies with the FCC requirements

Test/Witness Engineer :

IWAN SU

Approved & Authorized :

Ray Lai



This report details the results of the testing carried out on one sample. The results contained in this test report do not relate to other samples of the same product. The manufacturer should ensure that all products in series production are in conformity with the product sample detailed in the report.

Contents

CONTENTS	2
1. GENERAL INFORMATION ABOUT EUT	4
1.1 Client Information.....	4
1.2 General Description of EUT (Equipment Under Test)	4
1.3 Block Diagram Showing the Configuration of System Tested.....	5
1.4 Description of Support Units	5
1.5 Description of Test Mode.....	5
1.6 Measurement Uncertainty	6
1.7 Test Facility.....	7
2. TEST SUMMARY	8
3. TEST EQUIPMENT	9
4. FREQUENCY STABILITY	10
4.1 Test Standard and Requirement	10
4.2 Test Setup.....	10
4.3 Test Procedure.....	11
4.4 EUT Operating Condition	11
5. CONDUCTED RF OUTPUT POWER	14
5.1 Test Standard and Limit.....	14
5.2 Test Setup.....	14
5.3 Test Procedure.....	14
5.4 EUT Operating Condition	14
5.5 EUT Operating Condition	14
6. PEAK-AVERAGE RATIO	16
6.1 Test Standard and Limit.....	16
6.2 Test Setup.....	16
6.3 Test Procedure.....	16
6.4 EUT Operating Condition	16
6.5 Test Data.....	17
7. RADIATED OUTPUT POWER	19
7.1 Test Standard and Limit.....	19
7.2 Test Setup.....	19
7.3 Test Procedure.....	20
7.4 EUT Operating Condition	20
7.5 Test Data.....	21
8. OCCUPIED BANDWIDTH	22
8.1 Test Standard and Limit.....	22
8.2 Test Setup.....	22

8.3 Test Procedure.....	22
8.4 EUT Operating Condition	23
8.5 Test Data.....	23
9. CONDUCTED OUT OF BAND EMISSIONS.....	29
9.1 Test Standard and Limit.....	29
9.2 Test Setup.....	29
9.3 Test Procedure.....	29
9.4 EUT Operating Condition	29
9.5 Test Data.....	30
Please refer following plots:.....	30
10. BAND EDGE TEST	42
10.1 Test Standard and Limit	42
10.2 Test Setup.....	42
10.3 Test Procedure.....	42
10.4 EUT Operating Condition	42
10.5 Test Data.....	43
11. RADIATED OUT BAND OF EMISSIONS.....	45
11.1 Test Standard and Limit	45
11.2 Test Setup.....	45
11.3 Test Procedure.....	45
11.4 EUT Operating Condition	46
11.5 Test Data.....	46

1. General Information about EUT

1.1 Client Information

Applicant : ShenZhen Megastek Electronics Co. Ltd.
Address : RmB1111, Niulanqian Building, Minzhi Road, Longhua Town, Baoan District, Shenzhen, China
Manufacturer : Megastek Technologies Electronics (ShenZhen) Co. Ltd .
Address : Qiangcheng Technologis Park, Xinglang Road, Xingguang village, HuangjiangTown, DongguanCity, China

1.2 General Description of EUT (Equipment Under Test)

EUT Name	:	Home base unit
Models No.	:	S921, MT200-HBU, MT200XF
Model Difference	:	All these models are identical in the same PCB, layout and electrical circuit, the only difference is model name for commercial.
Product Description	:	Frequency Bands: GPRS 850; GPRS 1900;
	:	GPRS 850 Power : Cond:31.18 dBm ERP:30.89 dBm
	:	GPRS 1900 Power : Cond:28.30 dBm EIRP:27.84 dBm
	:	Antenna Gain: GPRS 850: 2 dBi PIFA Antenna GPRS 1900: 2 dBi PIFA Antenna
	:	Modulation Type: GPRS:GMSK
FCC Operating Frequency	:	GPRS 850: 824.20MHz-848.80MHz GPRS 1900: 1850.20MHz-1909.80MHz
Emission Designator	:	GPRS 850: 240KG7W, GPRS 1900: 246KG7W
Power Supply	:	AC power by AC cable. DC power by Li-ion battery.
Power Rating	:	AC 100-240V, 50/60Hz DC 3.7V by 100mAh Li-ion battery.
Connecting I/O Port(S)	:	Please refer to the User's Manual

Note:

- (1) For a more detailed features description, please refer to the manufacturer's specifications or the User's Manual.
- (2) This test report only product for PCS Licensed Transmitter (PCB).

1.3 Block Diagram Showing the Configuration of System Tested

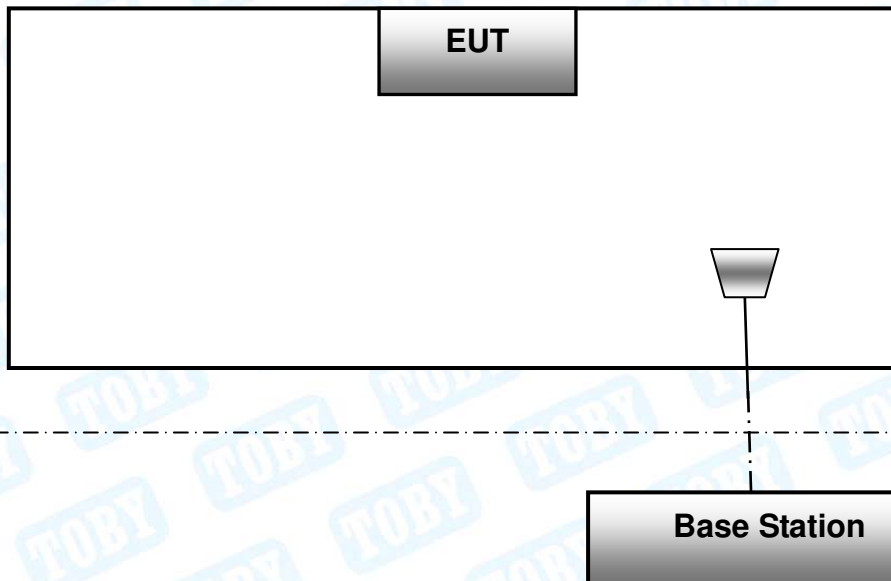

The above block diagram of setup is the normal mode. And more detail please refer to the test setup of each test item of bellow.

1.4 Description of Support Units

The EUT has been tested as an independent unit.

1.5 Description of Test Mode

To investigate the maximum EMI emission characteristics generates from EUT, the test system was pre-scanning tested base on the consideration of following EUT operation mode or test configuration mode which possible have effect on EMI emission level. Each of these EUT operation mode(s) or test configuration mode(s) mentioned follow was evaluated respectively.

During all testing, EUT is link mode with base station at maximum power level. The spurious emission measurements were carried out in semi-anechoic chamber with 3-meter test range. Frequency range investigated for radiated emission as below:

1. 9kHz~10GHz for GPRS 850.
2. 9kHz~20GHz for GPRS 1900.

Test Channel		
Mode	Channel	Frequency(MHz)
GPRS 850	128	824.20
	190	836.60
	251	848.80

GPRS 1900	512	1850.20
	661	1880.00
	810	1909.80
Pre-scanning test Mode		Description
GPRS 850		highest , middle, lowest channels
GPRS 1900		highest , middle, lowest channels
Final test Mode		Description
GPRS 850		highest , middle, lowest channels
GPRS 1900		highest , middle, lowest channels

Note:

- (1) The measurements are performed at the highest, middle, lowest available channels.
- (2) During the testing procedure, the EUT is in link mode with base station emulator at maximum power level in each test mode.
- (3) The EUT has GPRS functions, and after pre-testing, GPRS function is the worst case for all the emission tests.
- (4) The EUT is considered a fixed unit; it was pre-tested on the positioned of each 3 axis, X-plane, Y-plane and Z-plane. The worst case was found positioned on Z-plane as the normal use. Therefore only the test data of this Z-plane was used for radiated emission measurement test.

1.6 Measurement Uncertainty

Test Item	Parameters	Expanded Uncertainty (U _{Lab})
Conducted Emission	Level Accuracy: 9kHz~150kHz	±3.42 dB
	150kHz to 30MHz	±3.42 dB
Radiated Emission	Level Accuracy: 9kHz to 30 MHz	±4.60 dB
Radiated Emission	Level Accuracy: 30MHz to 1000 MHz	±4.40 dB
Radiated Emission	Level Accuracy: Above 1000MHz	±4.20 dB

1.7 Test Facility

The testing was performed by the Shenzhen Toby Technology Co., Ltd., in their facilities located at: 1A/F., Bldg.6, Yusheng Industrial Zone, The National Road No.107 Xixiang Section 467, Xixiang, Bao'an, Shenzhen, Guangdong, China.

At the time of testing, the following bodies accredited the Laboratory:

CNAS (L5813)

The Laboratory has been accredited by CNAS to ISO/IEC 17025: 2005 General Requirements for the Competence of Testing and Calibration Laboratories for the competence in the field of testing. And the Registration No.: CNAS L5813.

FCC List No.: (811562)

The Laboratory is listed in the United States of American Federal Communications Commission (FCC), and the registration number is 811562.

IC Registration No.: (11950A-1)

The Laboratory has been registered by Certification and Engineering Bureau of Industry Canada for radio equipment testing. The site registration: Site# 11950A-1.

2. Test Summary

Test Standards and Test Results			
Standard	Document Title		
FCC Part 2 (10-1-05 Edition)	Frequency Allocations and Radio Treaty Matters; General Rules and Regulations		
FCC Part 22 (10-1-05 Edition)	Public Mobile Services		
FCC Part 24 (10-1-05 Edition)	Personal Communications Services		
Standard Section	Test Item	Judgment	Remark
2.1046	Conducted RF Output Power	PASS	N/A
24.232(d)	Peak-Average Ratio	PASS	N/A
2.1049; 22.917; 24.238	99% & -26 dB Occupied Bandwidth	PASS	N/A
2.1055; 22.355; 24.235	Frequency Stability	PASS	N/A
2.1051; 2.1057; 22.917; 24.238	Conducted Out of Band Emissions	PASS	N/A
2.1051; 2.1057; 22.917; 24.238	Band Edge	PASS	N/A
22.913; 24.238	Transmitter Radiated Power (EIRP/ERP)	PASS	N/A
2.1053; 2.1057; 22.917; 24.238	Radiated Out of Band Emissions	PASS	N/A
Note: N/A is an abbreviation for Not Applicable.			

3. Test Equipment

AC Main Conducted Emission					
Description	Manufacturer	Model No.	Serial No.	Cal. Date	Cal. Due Date
EMI Test Receiver	ROHDE& SCHWARZ	ESCI	100321	Jul. 22, 2016	Jul. 21, 2017
50ΩCoaxial Switch	Anritsu	MP59B	X10321	Jul. 22, 2016	Jul. 21, 2017
L.I.S.N	Rohde & Schwarz	ENV216	101131	Jul. 22, 2016	Jul. 21, 2017
L.I.S.N	SCHWARZBECK	NNBL 8226-2	8226-2/164	Jul. 22, 2016	Jul. 21, 2017
Radiation Spurious Emission					
Description	Manufacturer	Model No.	Serial No.	Cal. Date	Cal. Due Date
Spectrum Analyzer	Agilent	E4407B	MY45106456	Jul. 22, 2016	Jul. 21, 2017
EMI Test Receiver	Rohde & Schwarz	ESCI	100010/007	Jul. 22, 2016	Jul. 21, 2017
Bilog Antenna	ETS-LINDGREN	3142E	00117537	Mar. 20, 2016	Mar. 19, 2017
Bilog Antenna	ETS-LINDGREN	3142E	00117542	Mar. 20, 2016	Mar. 19, 2017
Horn Antenna	ETS-LINDGREN	3117	00143207	Mar. 19, 2016	Mar. 18, 2017
Horn Antenna	ETS-LINDGREN	3117	00143209	Mar. 19, 2016	Mar. 18, 2017
Pre-amplifier	Sonoma	310N	185903	Mar. 20, 2016	Mar. 19, 2017
Pre-amplifier	HP	8449B	3008A00849	Mar. 26, 2016	Mar. 25, 2017
Cable	HUBER+SUHNER	100	SUCOFLEX	Mar. 26, 2016	Mar. 25, 2017
Signal Generator	Rohde & Schwarz	SML03	IKW682-054	Mar. 26, 2016	Mar. 25, 2017
Positioning Controller	ETS-LINDGREN	2090	N/A	N/A	N/A
Universal Radio Communication Tester	Rohde&Schwarz	CMU200	103903	Jun.23, 2016	Jun.22, 2017
Antenna Conducted Emission					
Description	Manufacturer	Model No.	Serial No.	Cal. Date	Cal. Due Date
Spectrum Analyzer	Agilent	E4407B	MY45106456	Jul. 22, 2016	Jul. 21, 2017
Spectrum Analyzer	Rohde & Schwarz	ESCI	100321	Jul. 22, 2016	Jul. 21, 2017
Universal Radio Communication Tester	Rohde&Schwarz	CMU200	103903	Jun.23, 2016	Jun.22, 2017

4. Frequency Stability

4.1 Test Standard and Requirement

4.1.1 Test Standard

FCC Part 2.1055

FCC Part 22.355

FCC Part 24.235

4.1.2 Requirement

According to FCC section 22.355 and FCC section 24.235, the frequency stability shall be sufficient to ensure that the fundamental emission stays within the authorized frequency block. According to FCC section 2.1055, the test conditions are:

(1) Temperature:

The temperature is varied from -30°C to $+50^{\circ}\text{C}$ at intervals of not more than 10°C .

(2) Primary Supply Voltage:

For hand carried battery powered equipment, the primary supply voltage is reduced to the battery operating end point which shall be specified by the manufacture. The supply voltage shall be measured at input to the cable normally provide with the equipment, or at the power supply terminals if cables are not normally provided.

4.2 Test Setup

For Temperature Test:

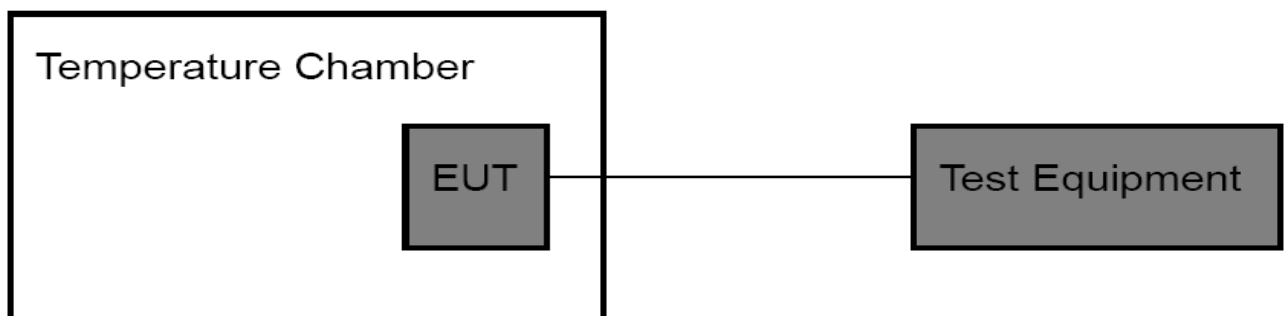

For Voltage Test:

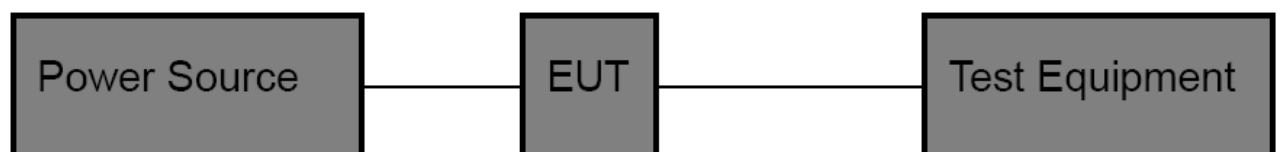

4.3 Test Procedure

Test Procedures for Temperature Variation:

- (1) The EUT was set up in the thermal chamber and connected with the base station.
- (2) With power off, the temperature was decreased to -30°C and the EUT was stabilized for three hours. Power was applied and the maximum change in frequency was recorded within one minute.
- (3) With power off, the temperature was raised in 10°C set up to 50°C and the EUT was stabilized for three hours. Power was applied and the maximum change in frequency was recorded within one minute.
- (4) If the EUT cannot be turned on at -30°C , the testing lowest temperature will be raised in 10°C step until the EUT can be turned on.

Test Procedures for Voltage Variation:

- (1) The EUT was placed in a temperature chamber at $25 \pm 5^{\circ}\text{C}$ and connected with the base station.
- (2) Reduce the input voltage to specify extreme voltage variation ($\pm 15\%$) and endpoint, record the maximum frequency change.
- (3) The variation in frequency was measured for the worst case.

4.4 EUT Operating Condition

The Equipment Under Test was set to Communication with the Base Station.

3.5 Test Data

Please refer the following pages.

Temperature Variation

Temperature Variation GPRS 850 (CH190)		
Temperature (°C)	GPRS	
	Freq. Dev. (Hz)	Deviation (ppm)
-30	3	0.004
-20	8	0.010
-10	5	0.006
0	6	0.007
10	7	0.008
20	2	0.002
30	9	0.011
40	3	0.004
50	4	0.005
60	5	0.006
Limit	2.5 (ppm)	
Result	PASS	

Temperature Variation GPRS 1900 (CH661)		
Temperature (°C)	GPRS	
	Freq. Dev. (Hz)	Deviation (ppm)
-30	12	0.018
-20	10	0.015
-10	9	0.014
0	6	0.009
10	8	0.012
20	5	0.008
30	7	0.011
40	6	0.009
50	4	0.006
60	11	0.017
Limit	2.5 (ppm)	
Result	PASS	

Voltage Variation

Voltage Variation GPRS 850 (CH190)		
Voltage (V)	GPRS	
	Freq. Dev. (Hz)	Deviation (ppm)
3.15	13	0.016
3.70	10	0.012
4.26	14	0.017
Limit	2.5 (ppm)	
Result	PASS	

Voltage Variation GPRS 1900 (CH661)		
Voltage (V)	GPRS	
	Freq. Dev. (Hz)	Deviation (ppm)
3.15	15	0.023
3.70	18	0.027
4.26	11	0.017
Limit	2.5 (ppm)	
Result	PASS	

5. Conducted RF Output Power

5.1 Test Standard and Limit

5.1.1 Test Standard

FCC Part 2: 2.1046

FCC Part 22H : 22.913 (a)

FCC Part 24E: 24.232 (c)

5.1.2 Test Limit

GSM850/UMTS Band V	PCS 1900/UMTS Band II
38.5 dBm (ERP)	33 dBm (EIRP)

5.2 Test Setup

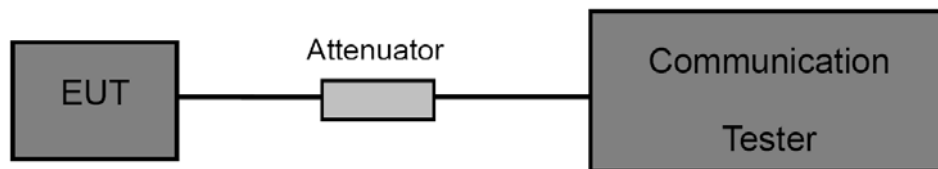

5.3 Test Procedure

- (1) The EUT is coupled to the Base Station with the suitable Attenuator, the path loss is calibrated to correct the reading.
- (2) A call is set up by the Base Station to the generic call set up procedure.
- (3) Set EUT at maximum power level through base station by power level command.
- (4) Then read record the power value from the Base Station in dBm.

5.4 EUT Operating Condition

The EUT was continuously connected with the Base station and transmitting in the max power during the test.

5.5 EUT Operating Condition

GPRS 850				
Mode	Channel	Frequency (MHz)	Conducted Power (dBm)	Conducted Power (W)
GPRS 850 (1 Slot)	128	824.2	31.18	1.312
	190	836.6	31.17	1.309
	251	848.8	31.14	1.300
GPRS 850 (2 Slot)	128	824.2	30.24	1.057
	190	836.6	30.12	1.028
	251	848.8	30.08	1.019
GPRS 850 (3 Slot)	128	824.2	29.14	0.820
	190	836.6	29.07	0.807
	251	848.8	29.15	0.822
GPRS 850 (4 Slot)	128	824.2	28.24	0.667
	190	836.6	28.13	0.650
	251	848.8	28.06	0.640

GPRS 1900				
Mode	Channel	Frequency (MHz)	Conducted Power (dBm)	Conducted Power (W)
GPRS 1900 (1 Slot)	512	1850.2	28.04	0.637
	661	1880.0	28.12	0.649
	810	1909.8	28.30	0.676
GPRS 1900 (2 Slot)	512	1850.2	27.12	0.515
	661	1880.0	27.04	0.506
	810	1909.8	27.08	0.511
GPRS 1900 (3 Slot)	512	1850.2	26.14	0.411
	661	1880.0	26.52	0.449
	810	1909.8	26.35	0.432
GPRS 1900 (4 Slot)	512	1850.2	25.11	0.324
	661	1880.0	25.09	0.323
	810	1909.8	25.18	0.330

6. Peak-Average Ratio

6.1 Test Standard and Limit

6.1.1 Test Standard

FCC Part 24E: 24.232 (d)

6.1.2 Test Limit

GPRS 1900

The peak-to-average ratio (PAR) of the transmission may not exceed 13 dB.

6.2 Test Setup

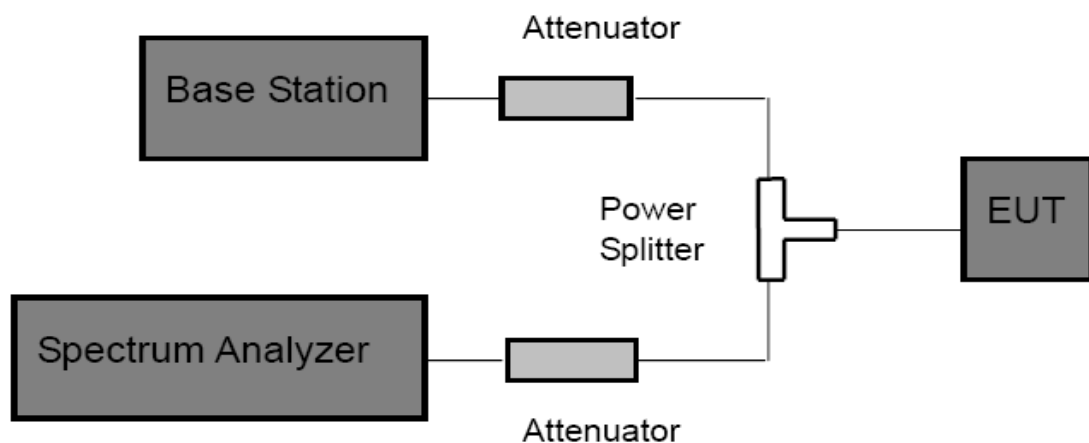

6.3 Test Procedure

According with KDB 971168

- (1) The signal analyzer's CCDF measurement profile is enabled.
- (2) Frequency = carrier center frequency.
- (3) Measurement BW > Emission bandwidth of signal.
- (4) The signal analyzer was set to collect one million samples to generate the CCDF curve.
- (5) The measurement interval was set depending on the type of signal analyzed. For continuous signals (>98% duty cycle), the measurement interval was set to 1ms. For burst transmissions, the spectrum analyzer is set to use an internal "RF Burst" trigger that is synced with an incoming pulse and the measurement interval is set to less than the duration of the "on time" of one burst to ensure that energy is only captured during a time in which of the transmitter is operating at maximum power.

6.4 EUT Operating Condition

The EUT was continuously connected with the Base station and transmitting in the max power

during the test.

6.5 Test Data

GPRS 1900(GPRS)			
Mode	Channel	Frequency (MHz)	Peak-Average Ratio (PAR)
GPRS 1900	512	1850.2	0.002
	661	1880.0	0.011
	810	1909.8	0.012

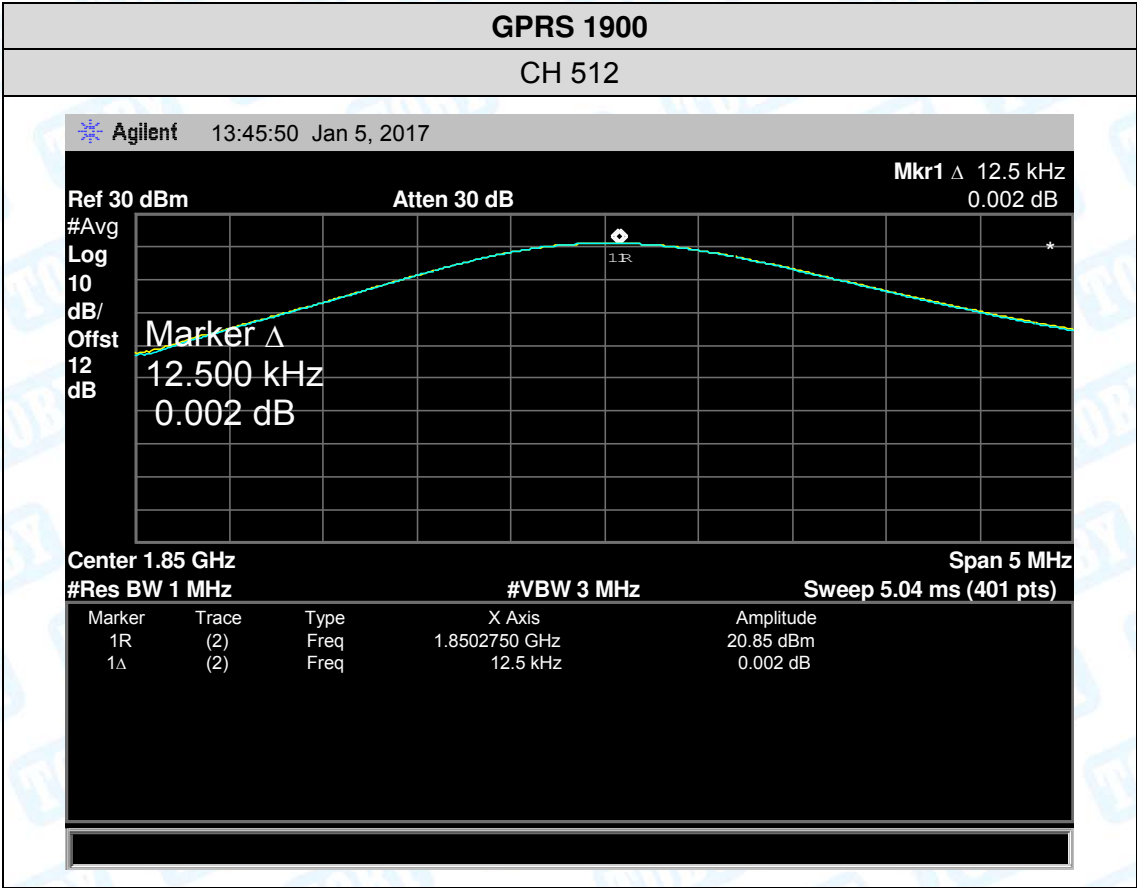

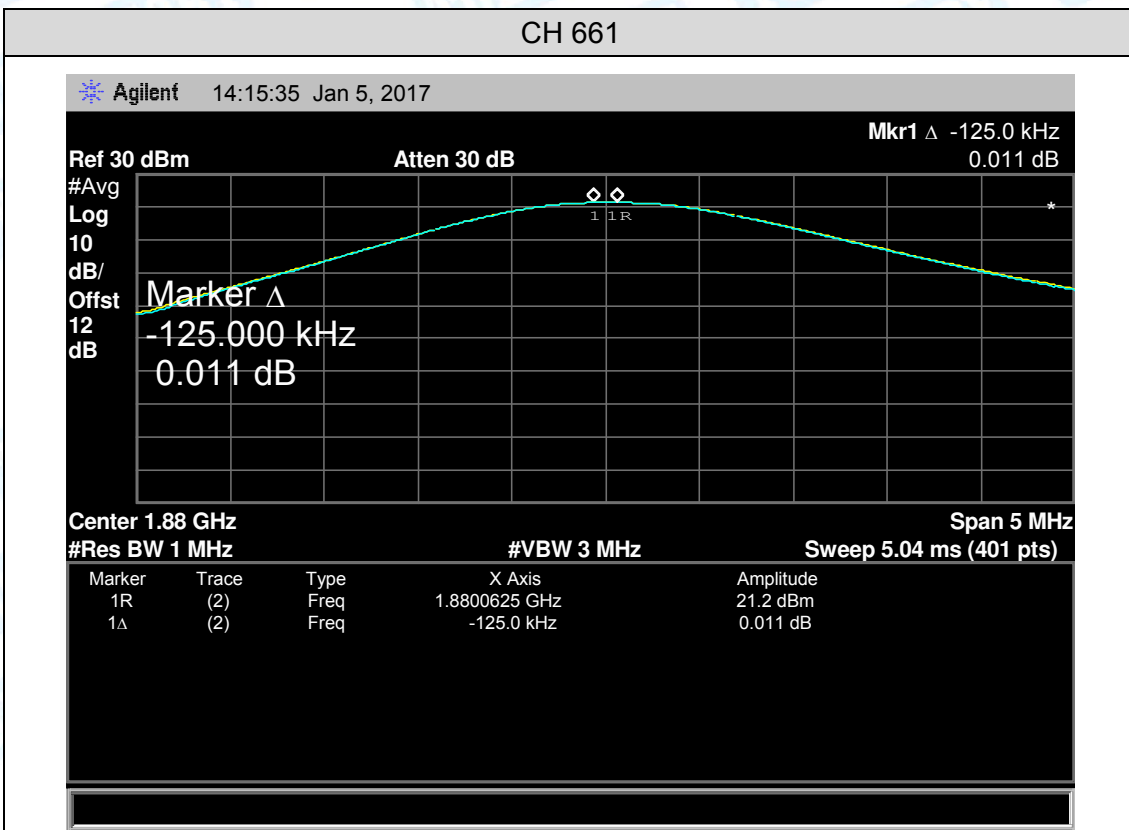

7. Radiated Output Power

7.1 Test Standard and Limit

7.1.1 Test Standard

FCC Part 22H : 22.913 (a)

FCC Part 24E: 24.232 (c)

7.1.2 Test Limit

According to FCC Part 22.913 (a), the ERP of Cellular mobile transmitters must not exceed 7 Watts(38.5 dBm).

According to FCC Part 24.232 (c), the Mobile/portable stations are limited to 2 Watts(33 dBm) EIRP peak power.

Cellular Band	PCS Band
GPRS 850	GPRS 1900
38.5 dBm (ERP)	33 dBm (EIRP)

7.2 Test Setup

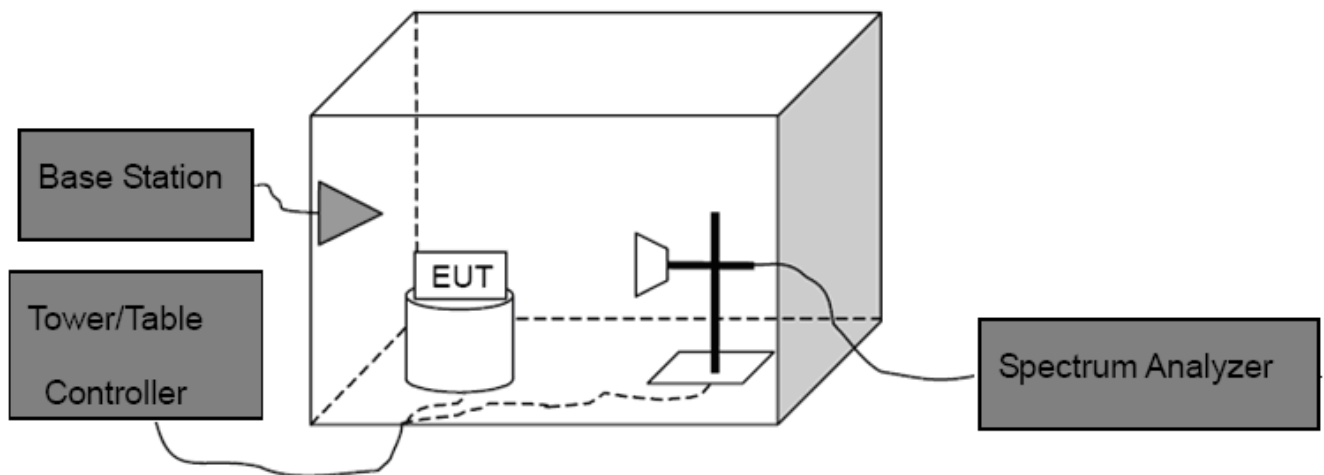

Above 1G

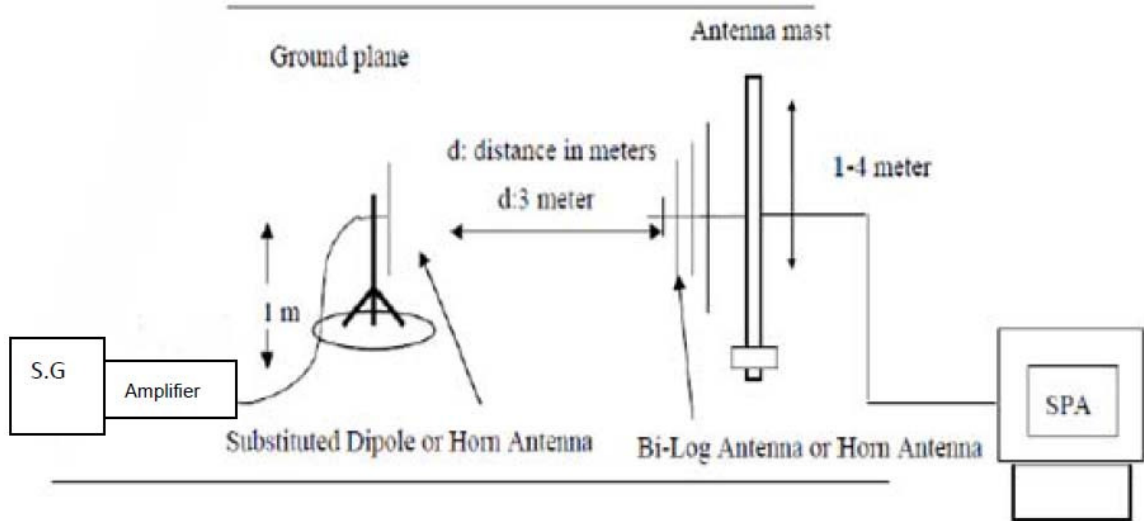

Substituted Method

7.3 Test Procedure

- (1) The EUT was placed on a non-conductive rotating platform with 0.8 meter height in an anechoic chamber. The radiated emission at the fundamental frequency was measured at 3 m with a test antenna and a spectrum analyzer with RBW=3 MHz, VBW=3 MHz and peak detector settings.
- (2) During the measurement, the EUT was enforced in maximum power and linked with the Base Station. The highest was recorded from analyzer power level (LVT) from the 360 degrees rotation of the turntable and the test antenna raised and lowered over a range from 1 to 4 meters in both horizontally and vertically polarized orientations.
- (3) Effective Isotropic Radiated Power (EIRP) was measured by substitution method according to C63.26. The EUT was replaced by dipole antenna (for frequency below 1 GHz) or Horn antenna (for frequency above 1 GHz) at same location with same polarize of receiver antenna and then a known power of each measure frequency from S.G. was applied into the dipole antenna or Horn antenna through a TX cable, and then recorded the maximum Analyzer reading through raised and lowered the test antenna.

Note: In test, the S.G. Connect the Pre-amplifier (Sonoma 310N Pre-amplifier for frequency below 1 GHz, HP 8449B Pre-amplifier for frequency above 1 GHz)

Then the EUT's EIRP and ERP was calculated with the correction factor:
 $ERP = S.G. Level + Antenna Gain Cord. (dBd) - Cable Loss (dB)$
 $EIRP = S.G. Level + Antenna Gain Cord. (dBi) - Cable Loss (dB)$

7.4 EUT Operating Condition

The EUT was continuously connected with the Base station and transmitting in the max power during the test.

7.5 Test Data

Measurement Data (worst case)

GPRS 850								
Mode	Channel	Frequency (MHz)	Antenna (H&V)	SG Level (dBm)	Antenna Factor (dBd)	Cable Loss (dB)	ERP Power (dBm)	ERP Power (W)
GPRS 850 (1 Slot)	128	824.2	H	28.69	3.46	1.26	30.89	1.227
			V	25.48	3.46	1.26	27.68	0.586
	190	836.6	H	28.20	3.82	1.26	30.76	1.191
			V	24.89	3.82	1.26	27.45	0.556
	251	848.8	H	28.04	4.16	1.26	30.94	1.242
			V	24.22	4.16	1.26	27.12	0.515
Limit							38.5	7

GPRS 1900								
Mode	Channel	Frequency (MHz)	Antenna (H&V)	SG Level (dBm)	Antenna Factor (dBi)	Cable Loss (dB)	EIRP Power (dBm)	EIRP Power (W)
GPRS 1900 (1 Slot)	512	1850.2	H	25.26	5.01	2.59	27.68	0.586
			V	22.95	5.01	2.59	25.37	0.344
	661	1880.0	H	25.61	4.82	2.59	27.84	0.608
			V	22.90	4.82	2.59	25.13	0.326
	810	1909.8	H	25.30	4.45	2.59	27.16	0.520
			V	23.19	4.45	2.59	25.05	0.320
Limit							33	2

8. Occupied Bandwidth

8.1 Test Standard and Limit

8.1.1 Test Standard

FCC Part 2: 2.1049

FCC Part 22H : 22.913 (a)

FCC Part 24E: 24.232 (c)

8.1.2 Test Requirement

According to FCC section 2.1049, the occupied bandwidth is the frequency bandwidth such that below its lower and above its upper frequency limits, the mean powers radiated are each equal to 0.5 percent of the total mean power radiated by a given emission.

Occupied bandwidth is also known as 99% power and -26dBC occupied bandwidths.

8.2 Test Setup

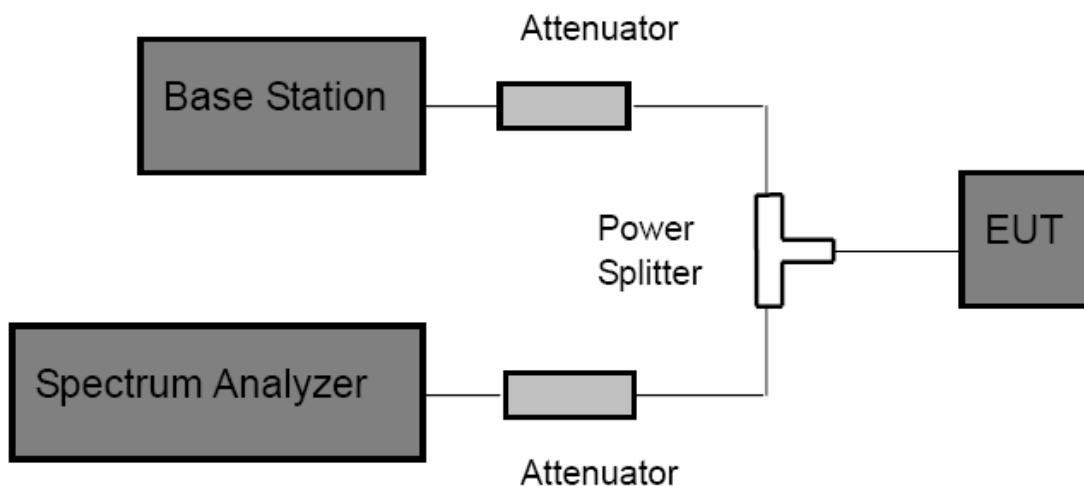

8.3 Test Procedure

- (1) The EUT was directly connected to the spectrum analyzer and Base station via power splitter as show in the block diagram above.
- (2) The resolution bandwidth of the Spectrum Analyzer is set to at least 1% of the occupied bandwidth.
- (3) The low, middle and the high channels are selected to perform tests respectively.
- (4) Set the frequency range of the Spectrum Analyzer suitably to capture the waveform; search peak; make a line whose value is 26dB lower than the peak; mark two points which the line intersected the waveform at; finally record the delta of the two points as the occupied bandwidth and the plot.
- (5) Set the Spectrum Analyzer Occupied bandwidth function to measure the 99% occupied bandwidth.

8.4 EUT Operating Condition

The EUT was continuously connected with the Base station and transmitting in the max power during the test.

8.5 Test Data

Please refer following pages.

GPRS 850				
Mode	Channel	Frequency (MHz)	99% OBW (MHz)	-26dB Bandwidth (kHz)
GPRS 850 (1 Slot)	128	824.2	239.1670	317.264
	190	836.6	239.9628	318.845
	251	848.8	239.6003	315.147
GPRS 1900				
Mode	Channel	Frequency (MHz)	99% OBW (MHz)	-26dB Bandwidth (kHz)
GPRS 1900 (1 Slot)	512	1850.2	241.3750	313.574
	661	1880.0	246.3260	321.191
	810	1909.8	245.2608	326.409

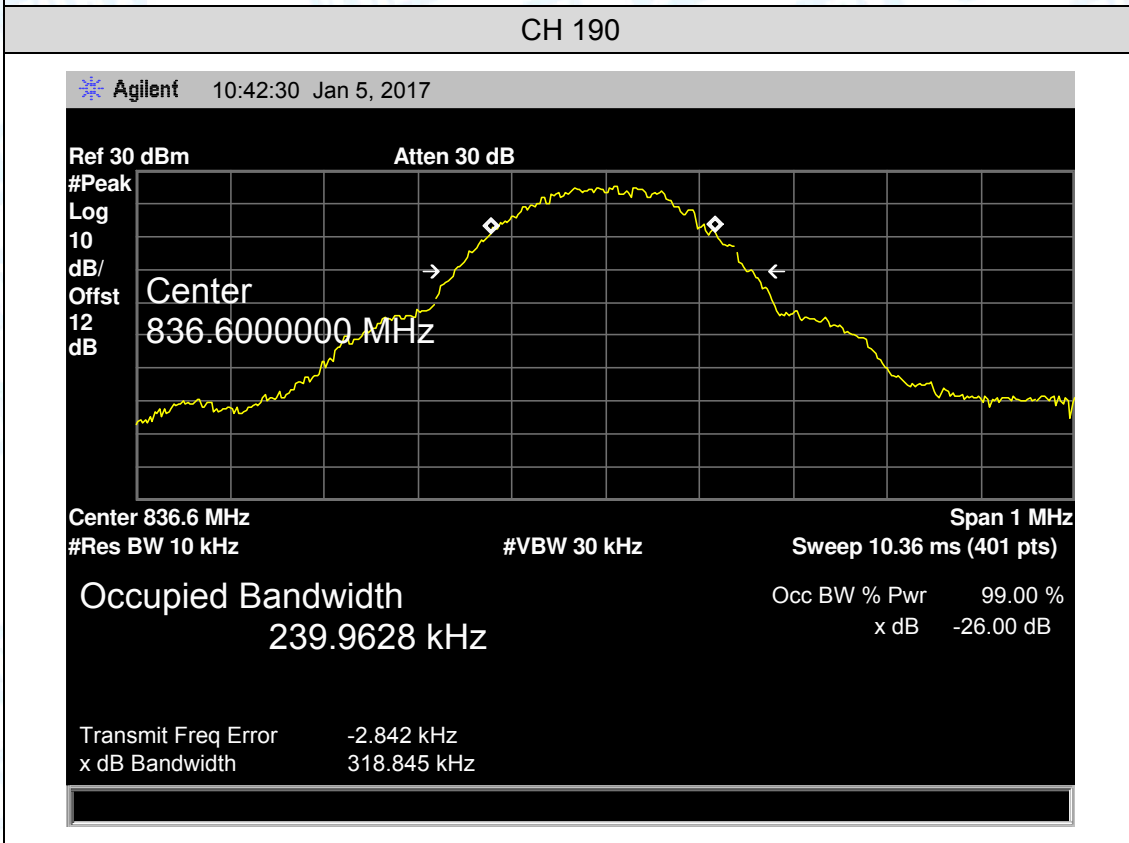
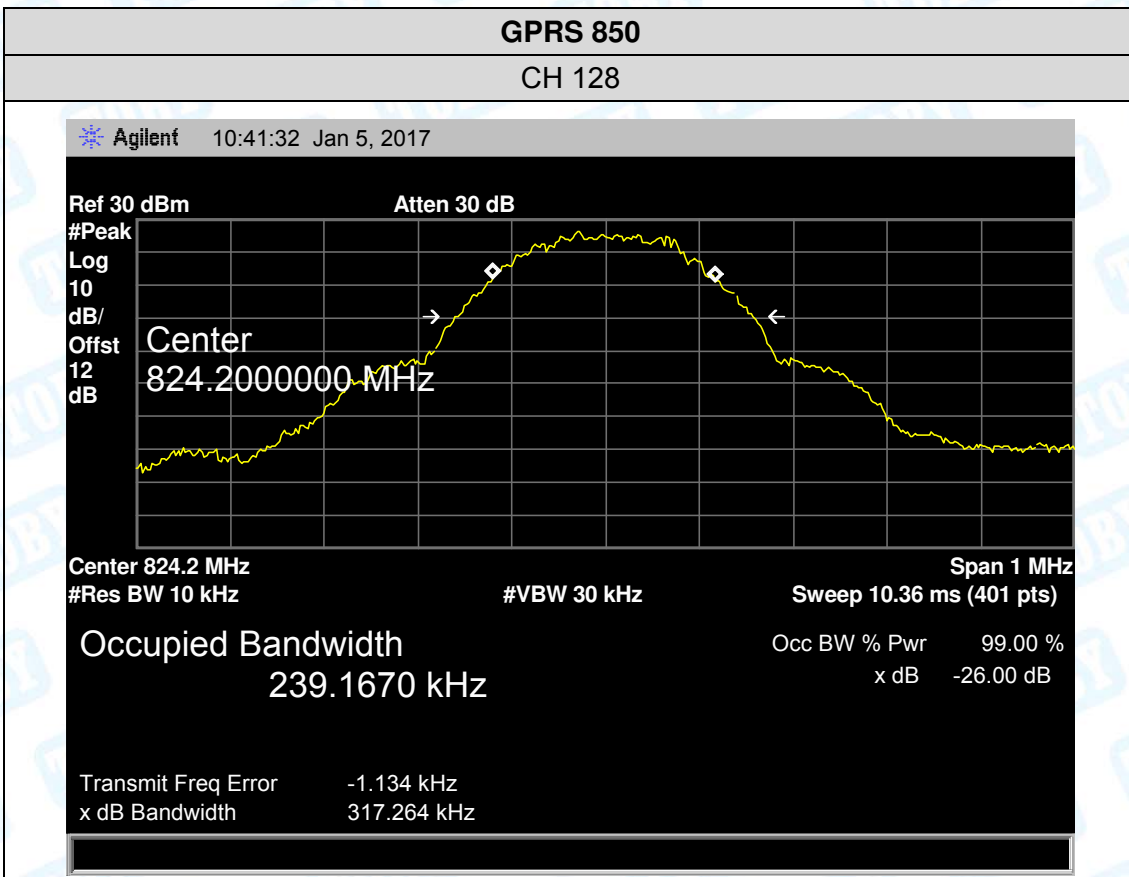

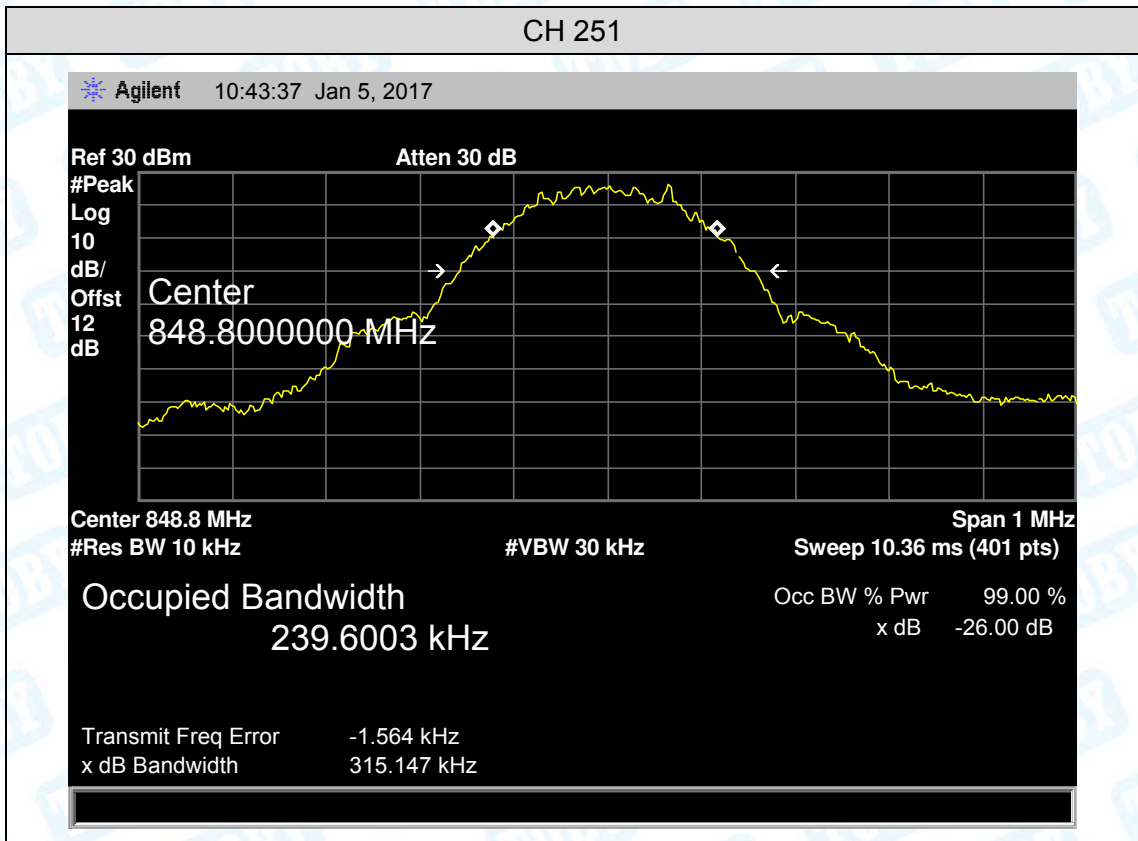

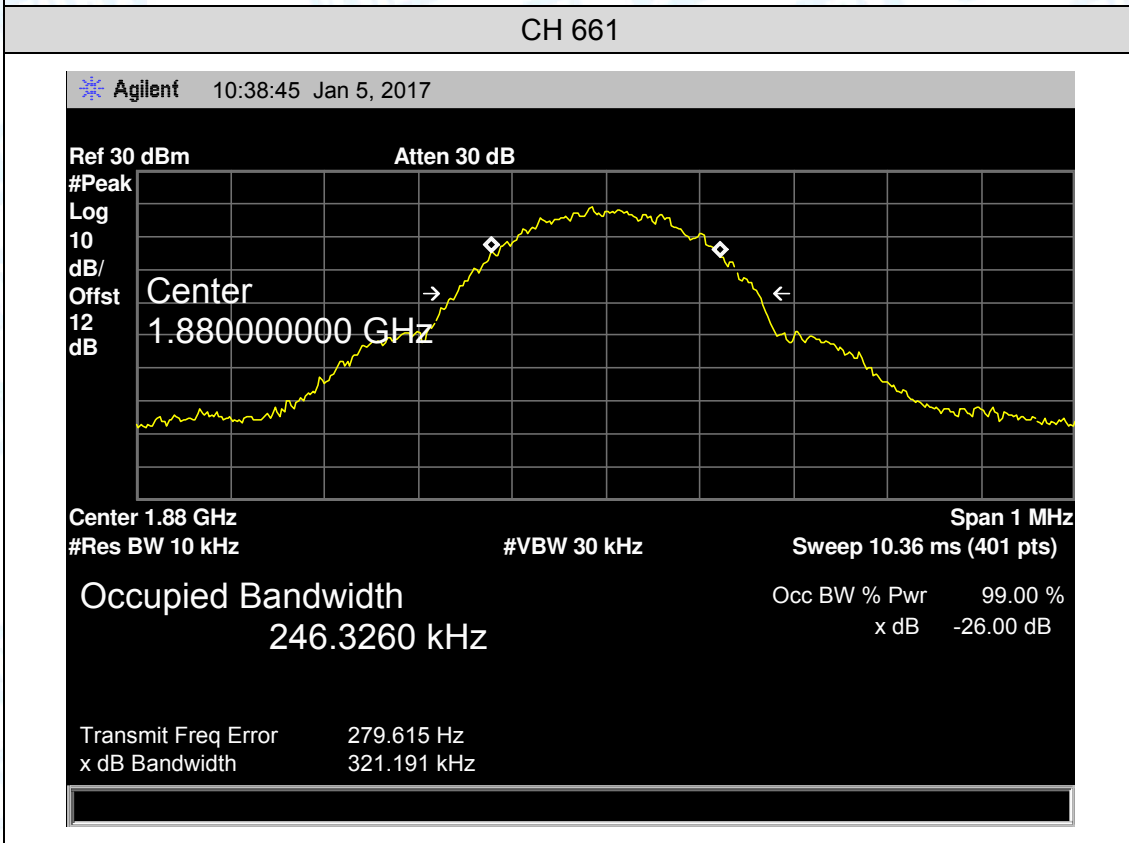
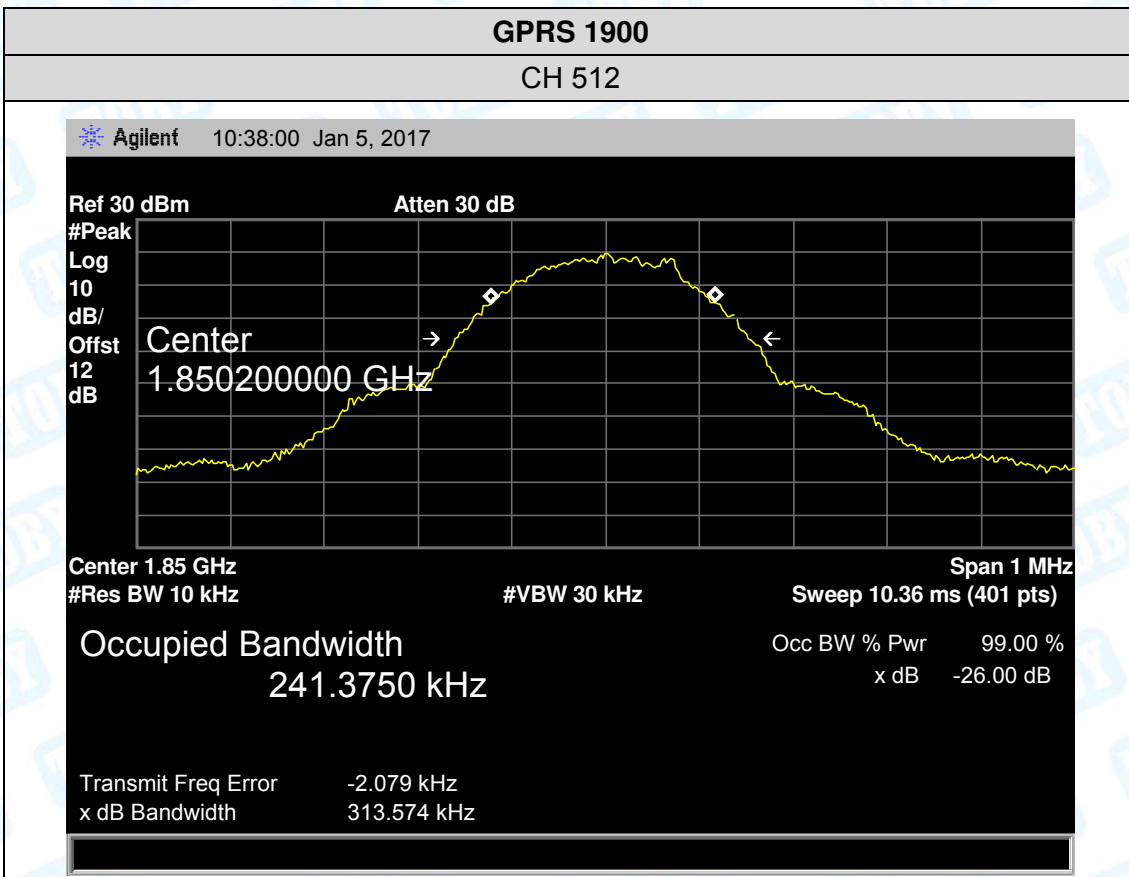

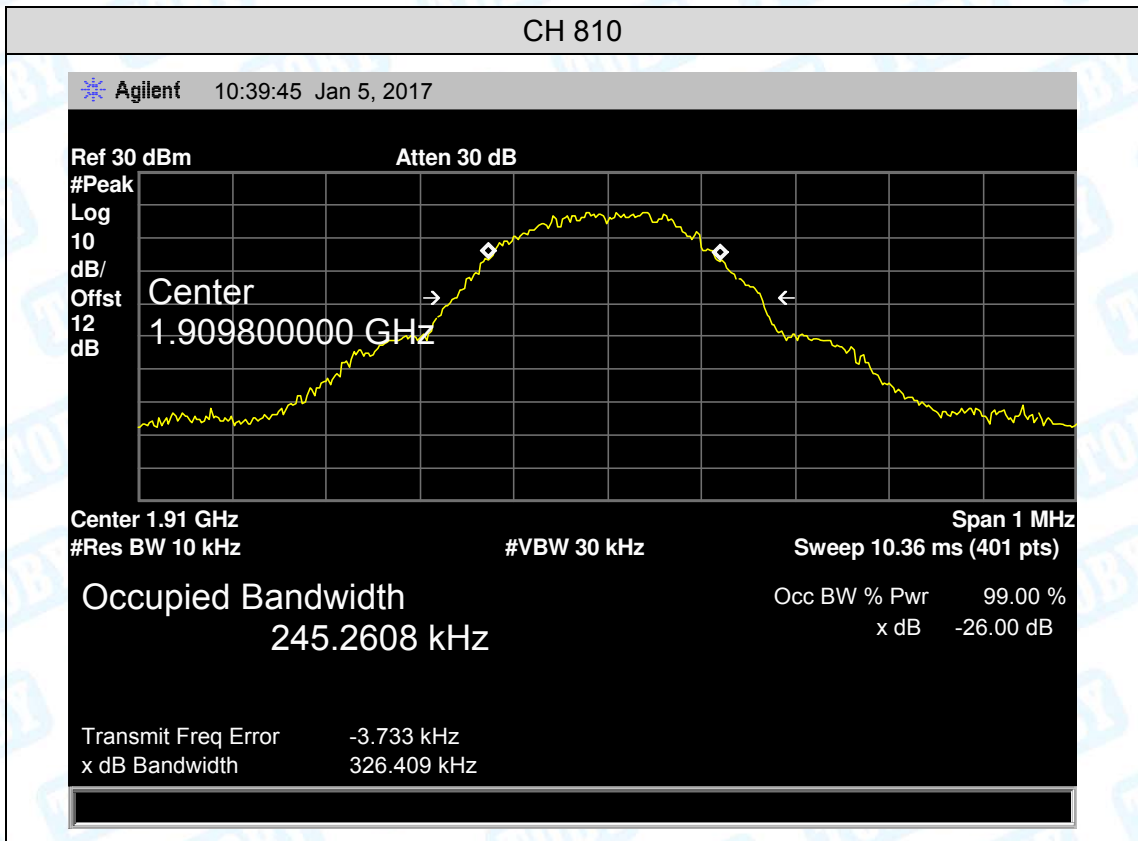

9. Conducted Out of Band Emissions

9.1 Test Standard and Limit

9.1.1 Test Standard

FCC Part 2: 2.1051, 2.1057

FCC Part 22H: 22.917(a)

FCC Part 24E: 24.238(a)

9.1.2 Test Limit

The power of any emission outside of the authorized operating frequency ranges must be attenuated below the transmitting power(P) by a factor of at least $43+10\log(P)$ dB. For all power levels +30 dBm to 0 dBm, this becomes a constant specification limit of -13 dBm.

9.2 Test Setup

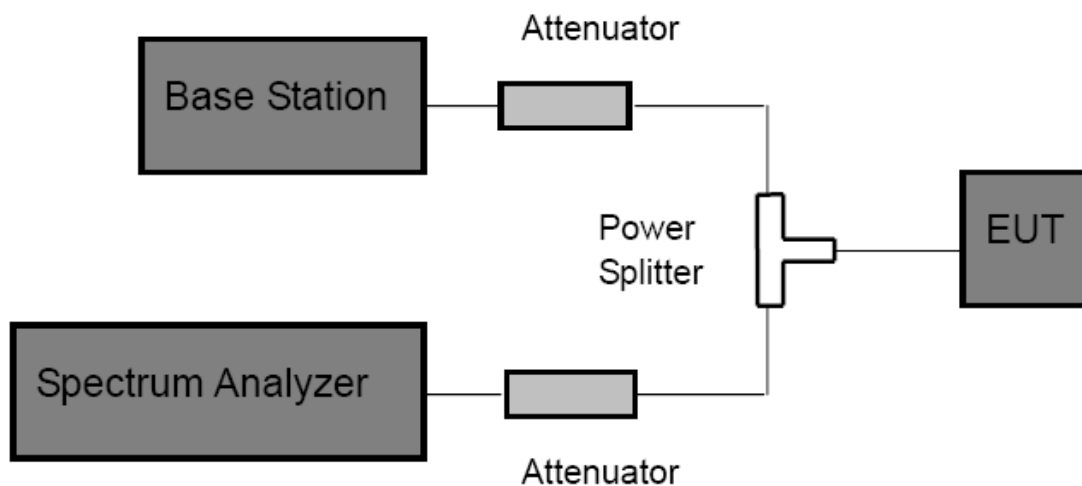

9.3 Test Procedure

- (1) The EUT was directly connected to the spectrum analyzer and Base station via power splitter as show in the block diagram above.
- (2) Spectrum Setting:
 Frequency bellow 1 GHz: RBW=100 kHz, VBW=300 kHz.
 Frequency above 1 GHz: RBW=1 MHz, VBW=3 MHz.
- (3) The low, middle and high channels of each band and mode's spurious emissions for 30 MHz to 10th Harmonic were measured by Spectrum analyzer.

9.4 EUT Operating Condition

The EUT was continuously connected with the Base station and transmitting in the max power during the test.

9.5 Test Data

Please refer following plots:

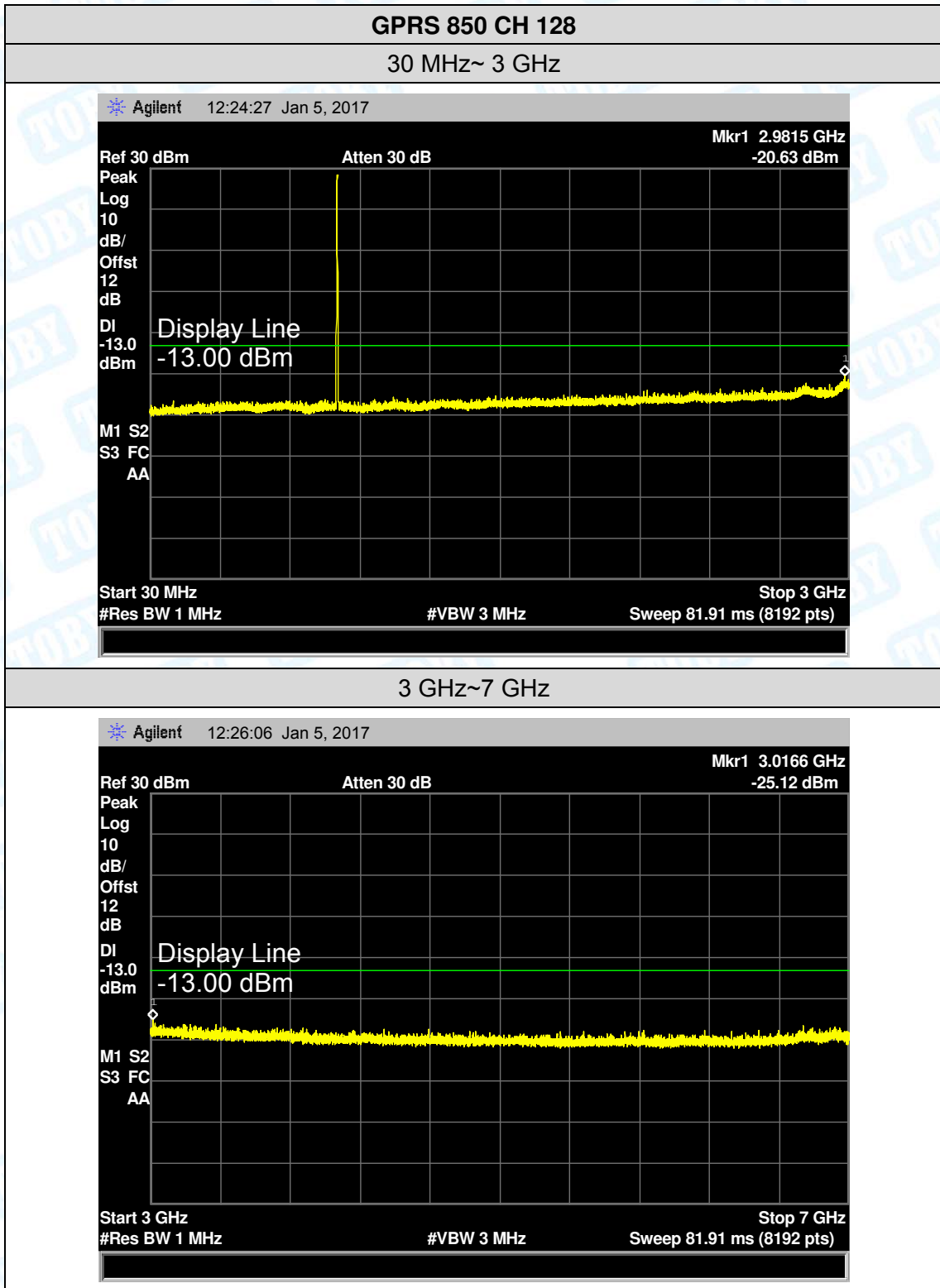

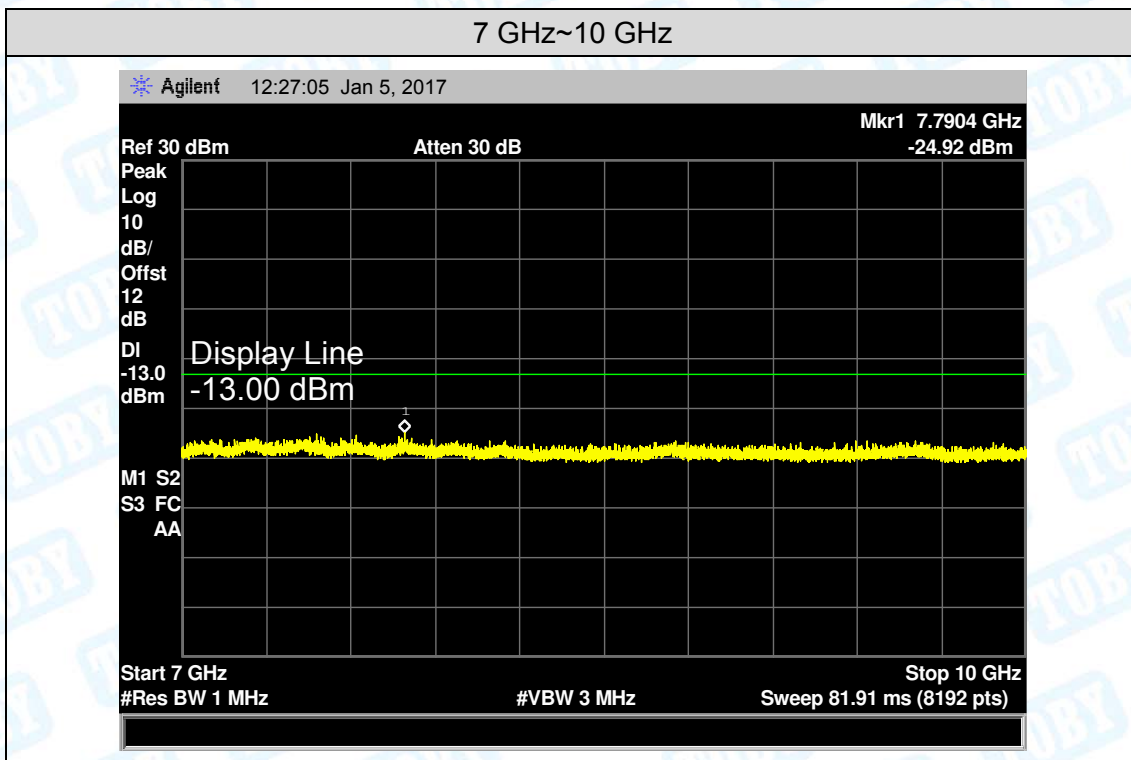

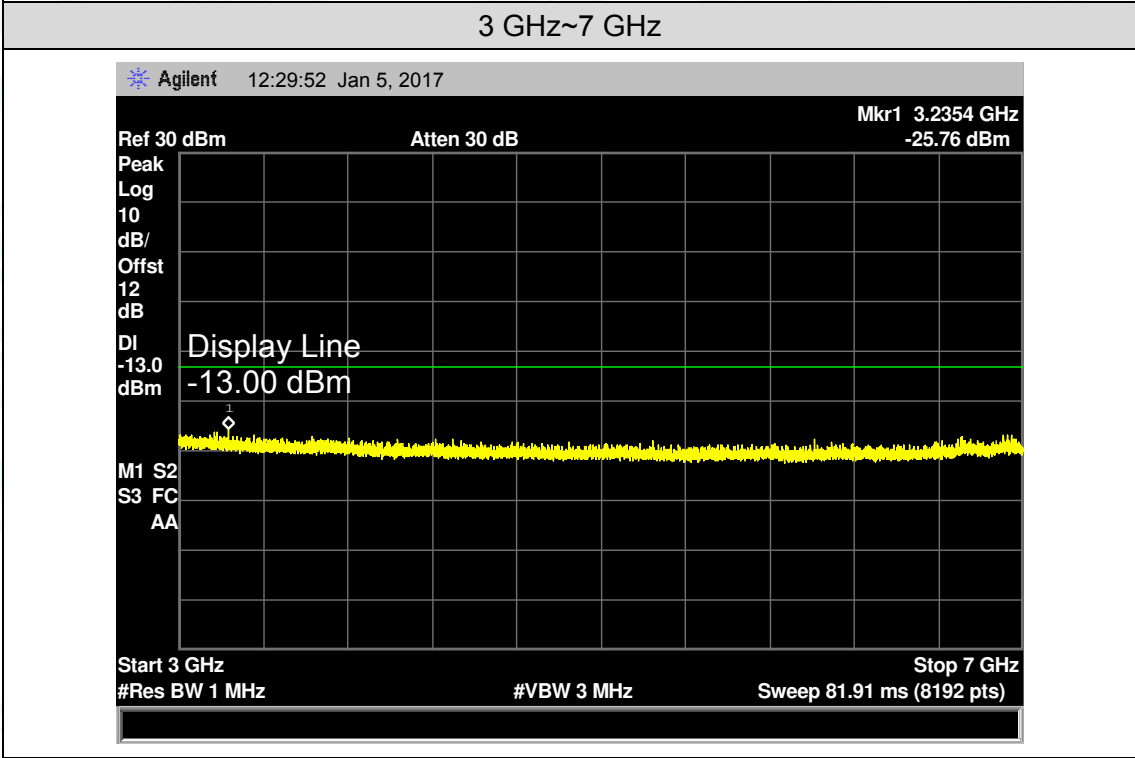
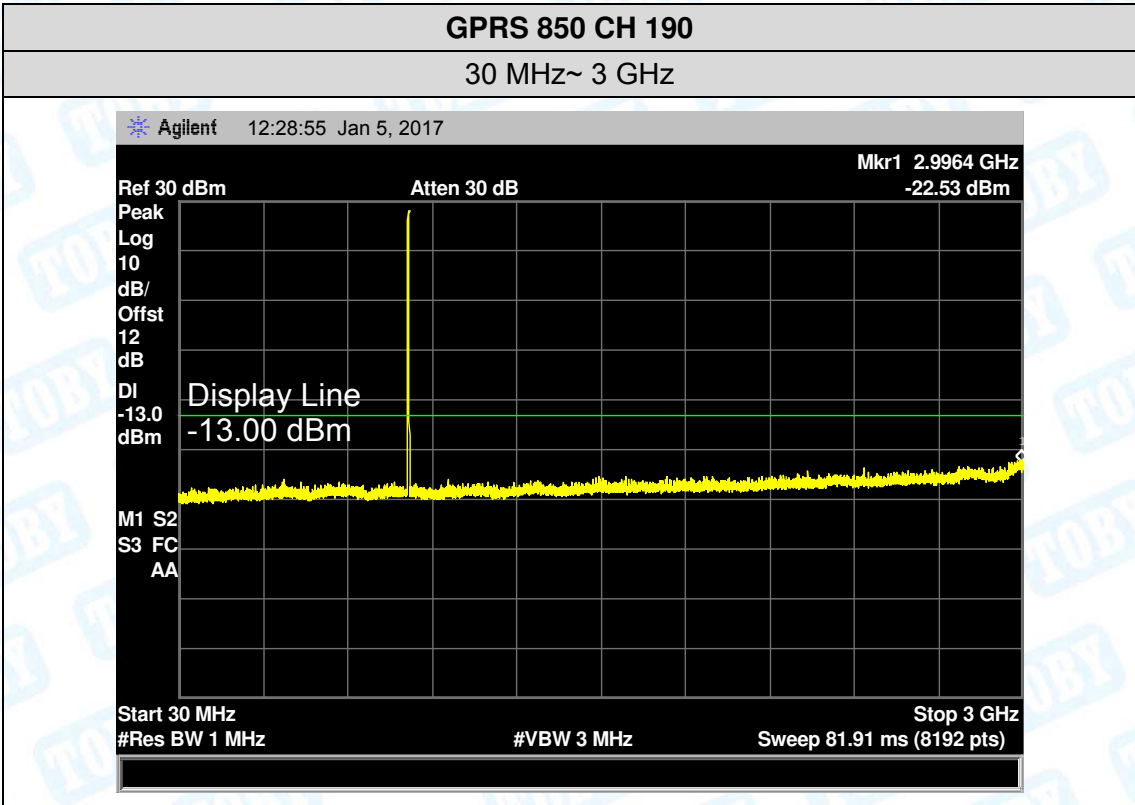

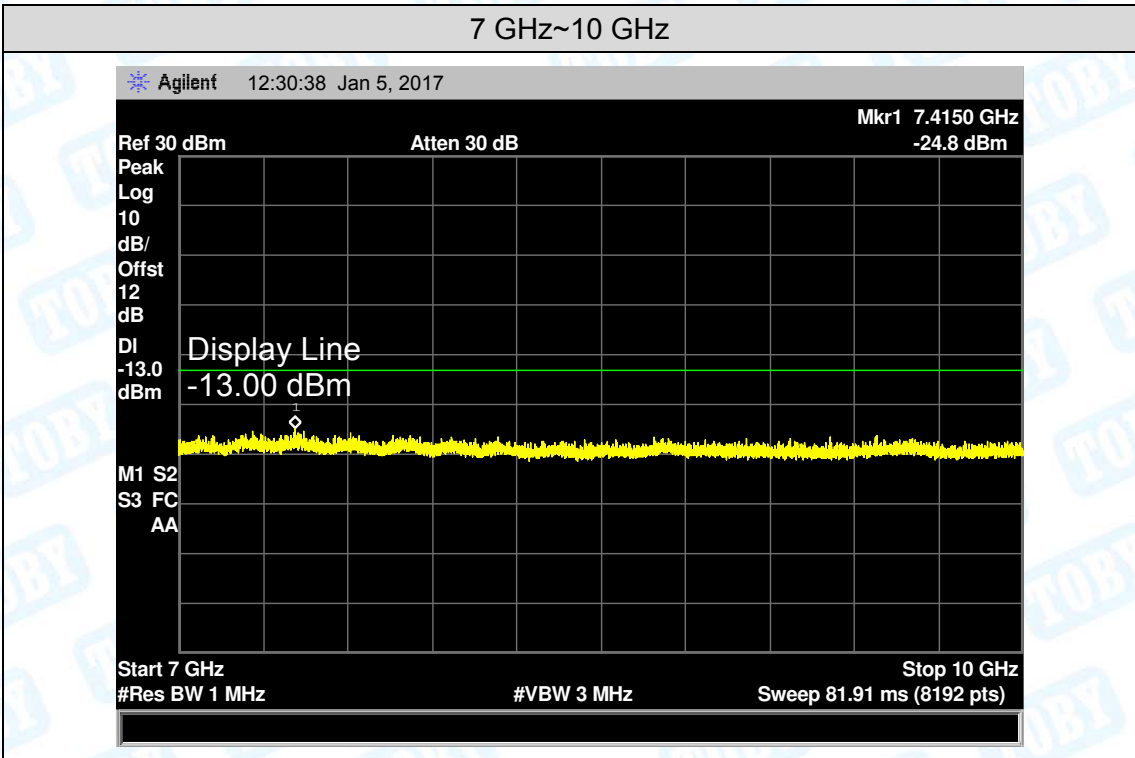

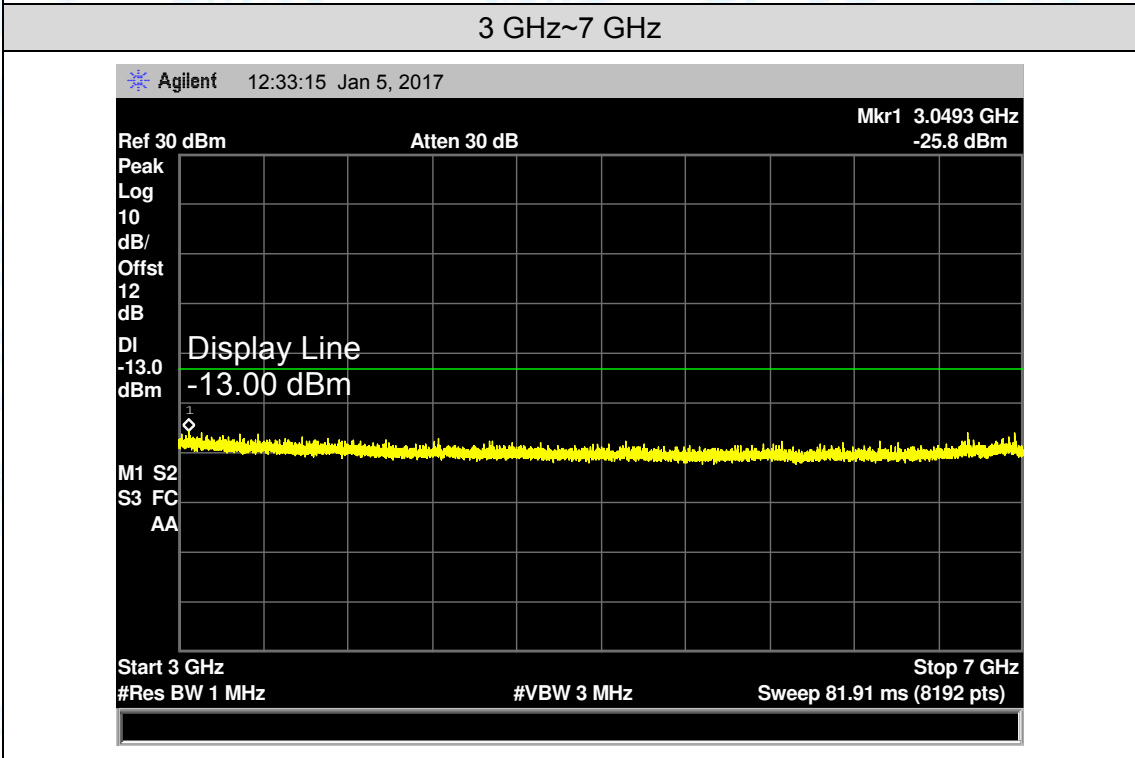
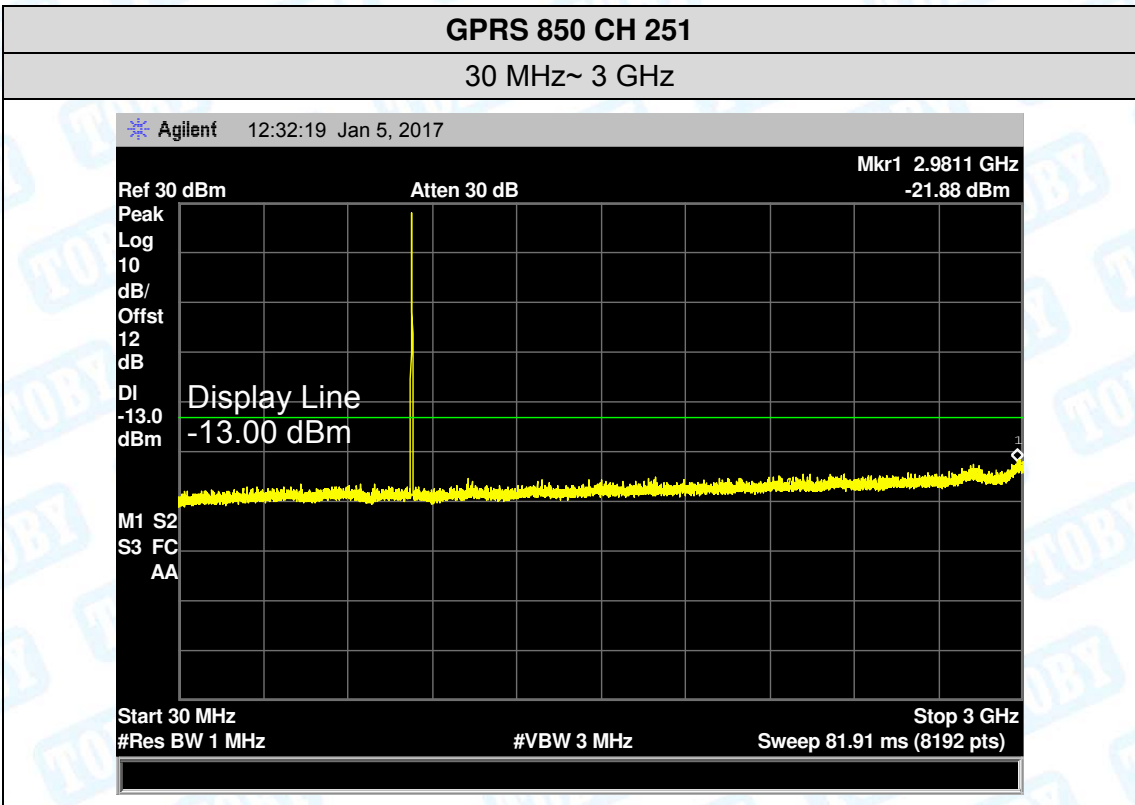

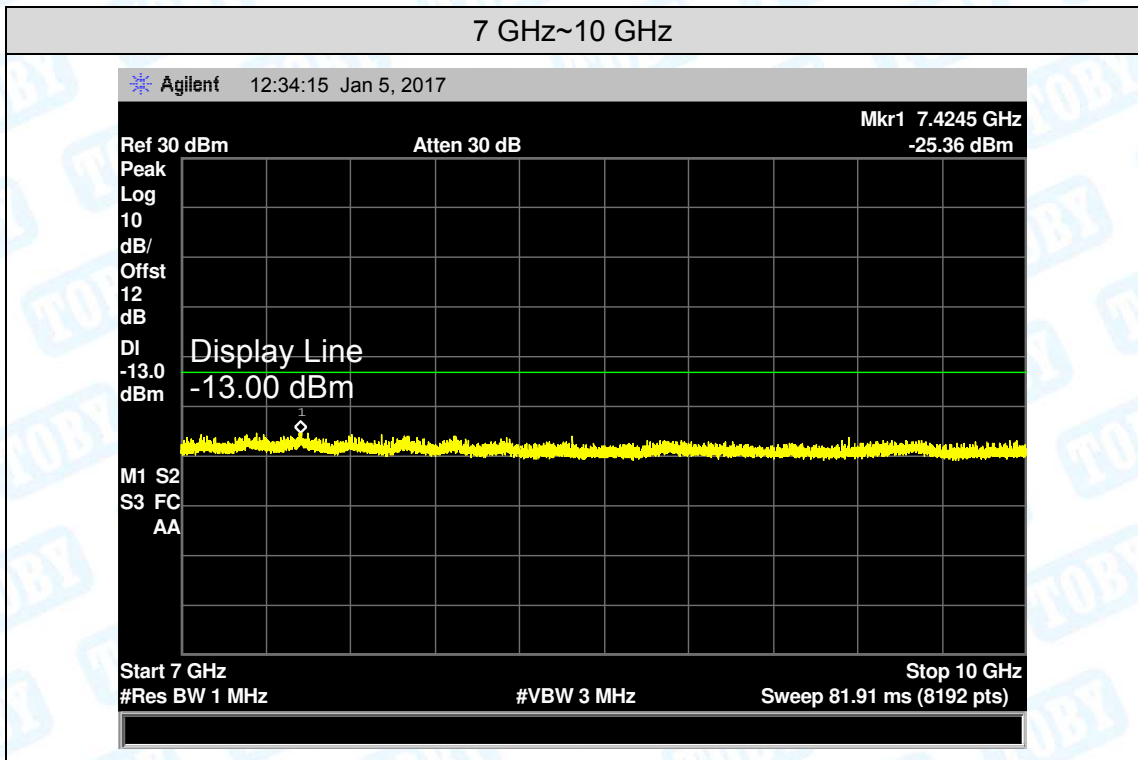

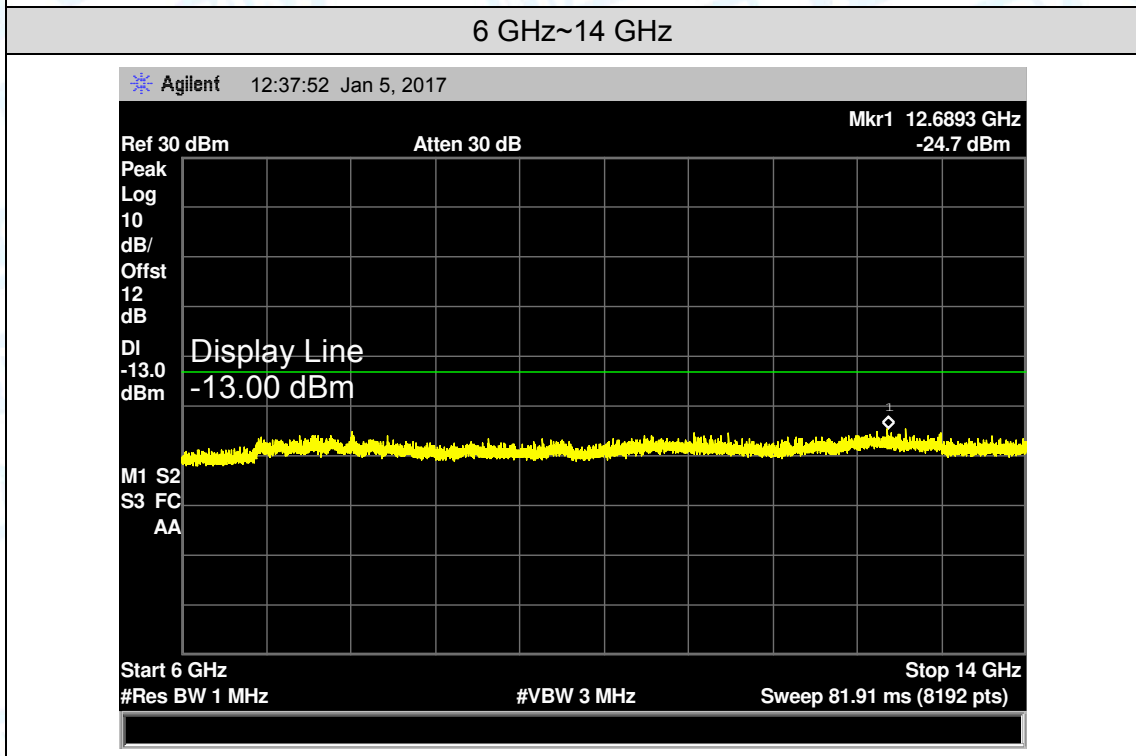
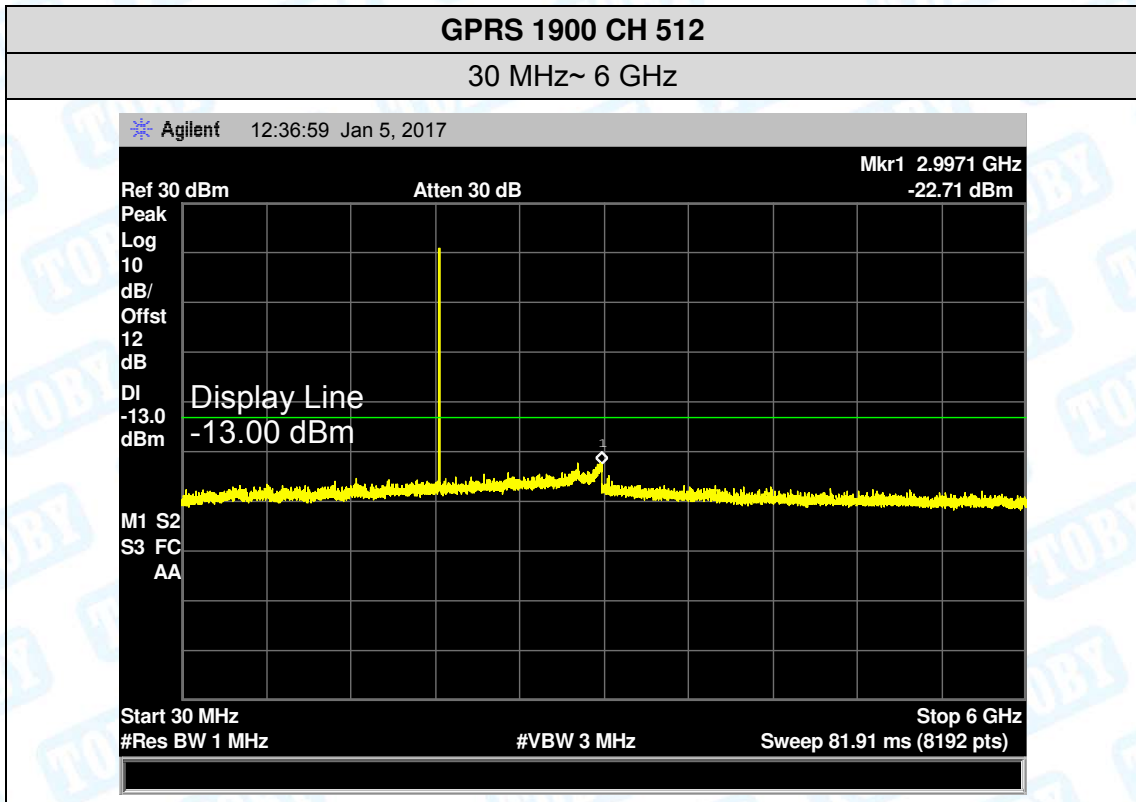

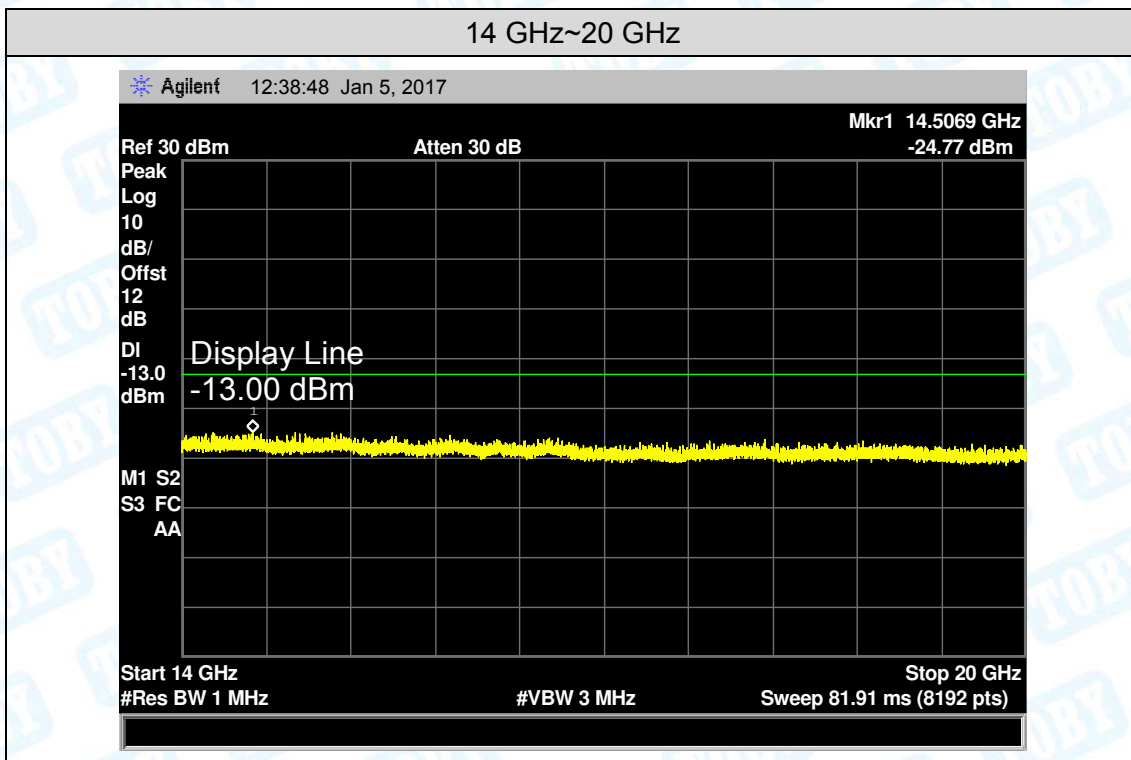

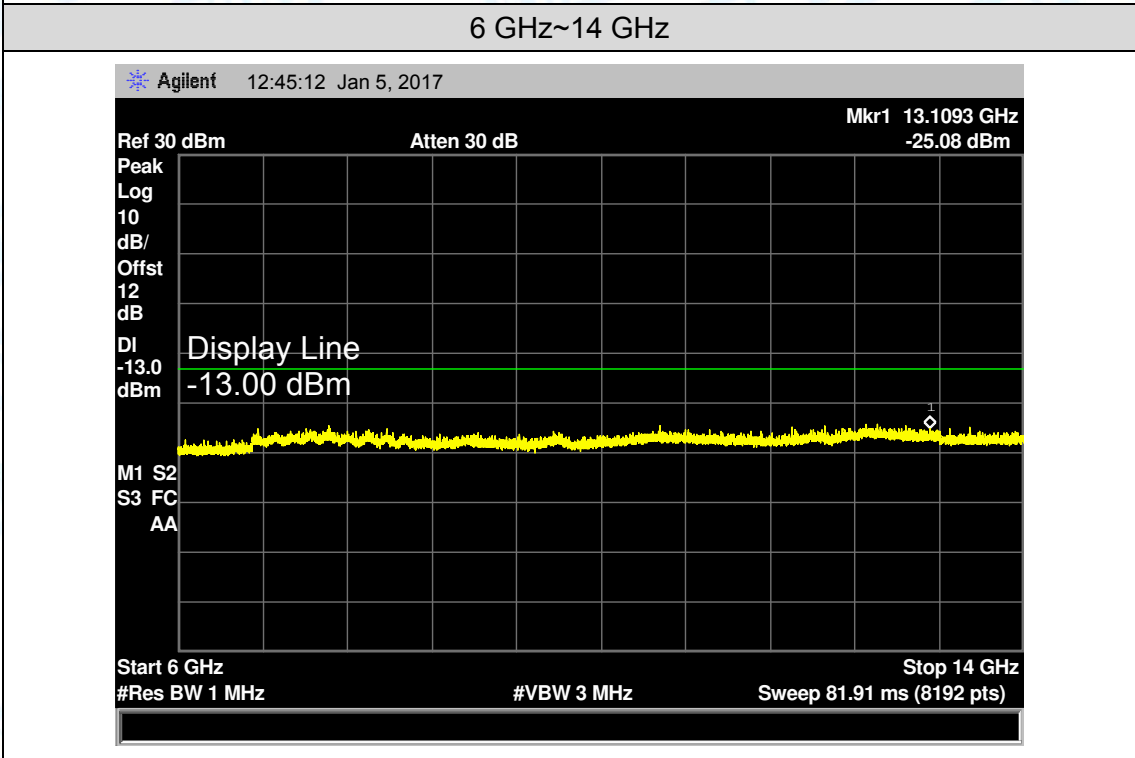
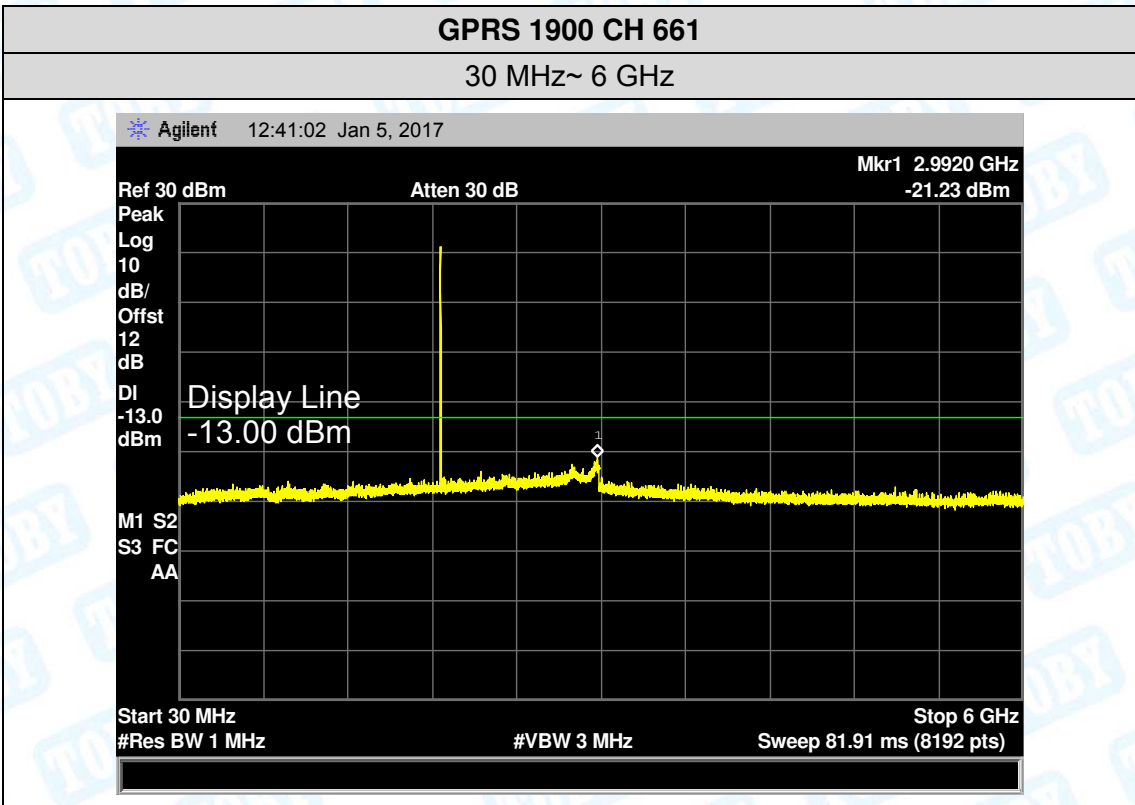

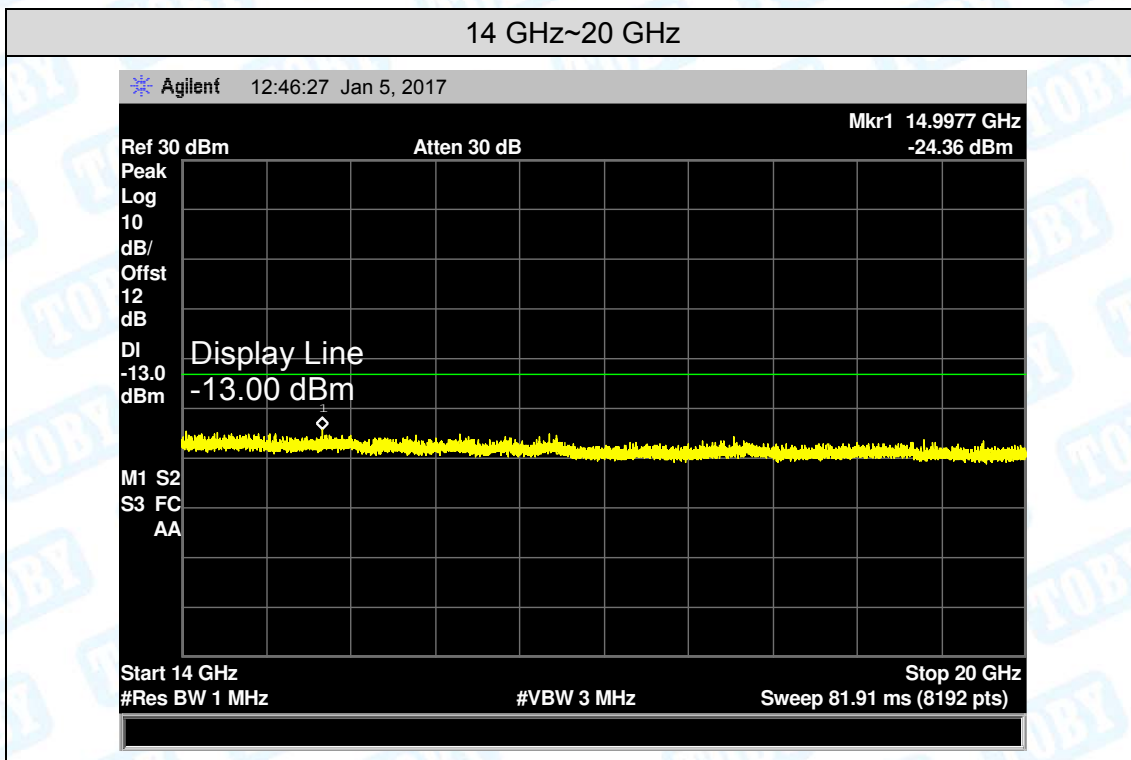

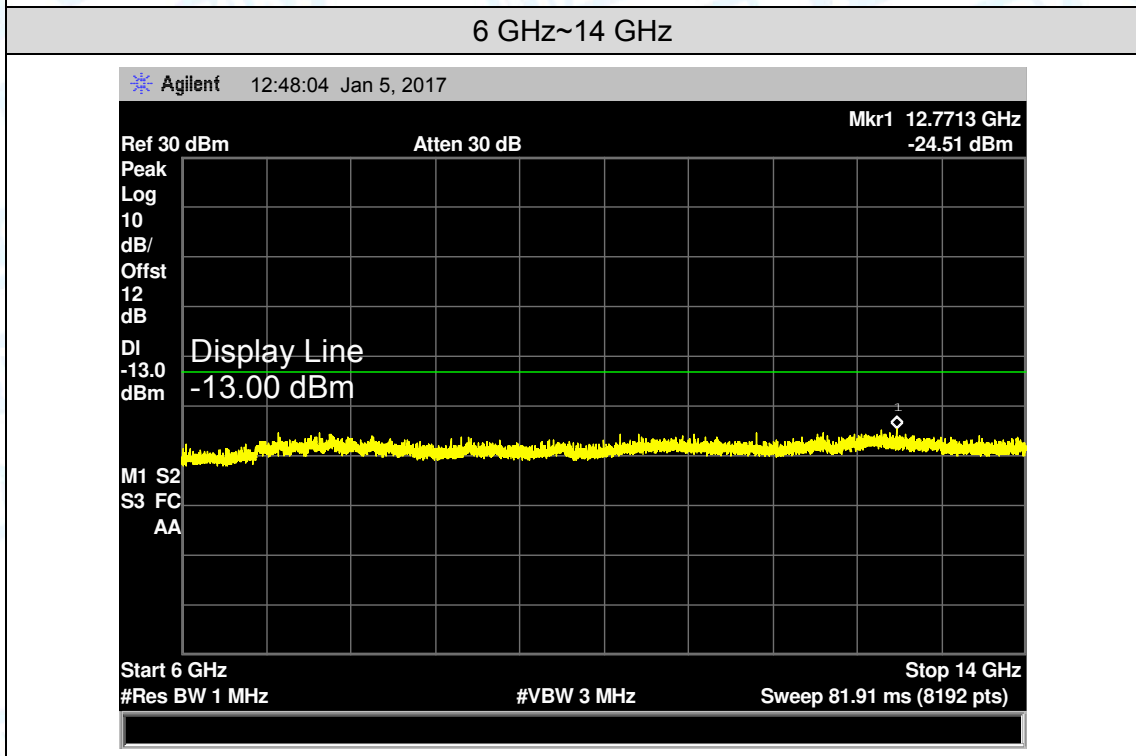
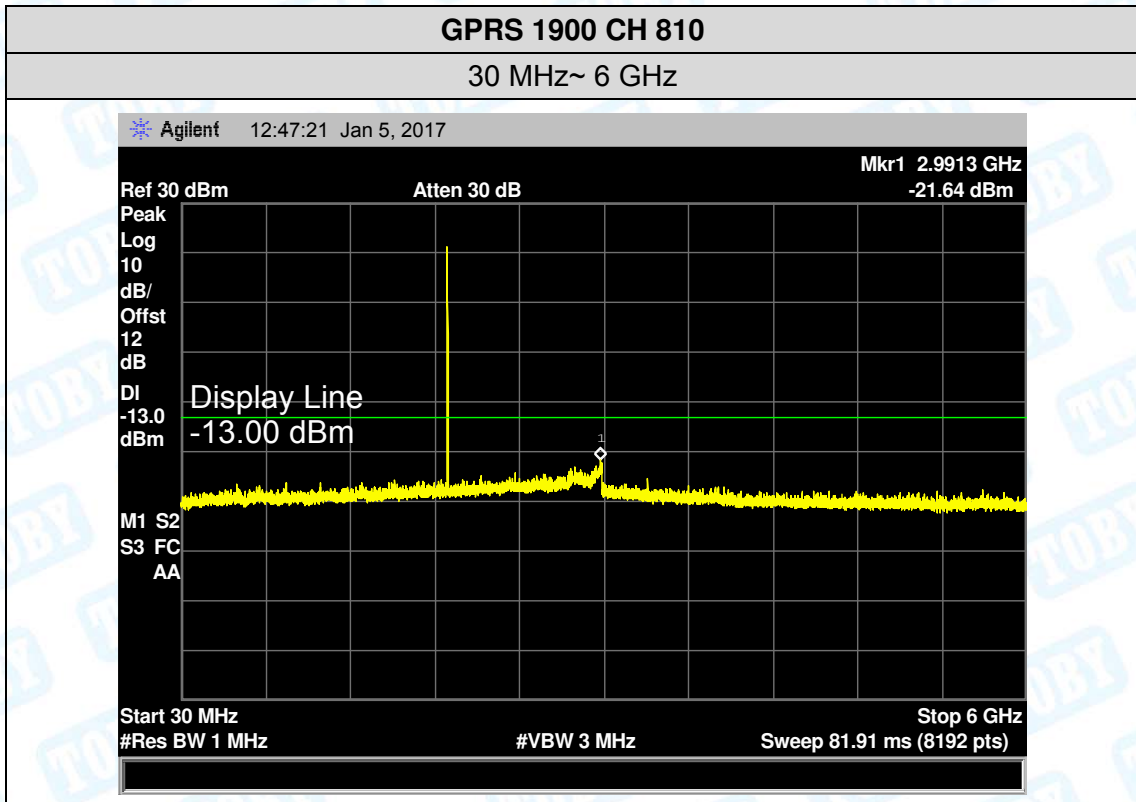

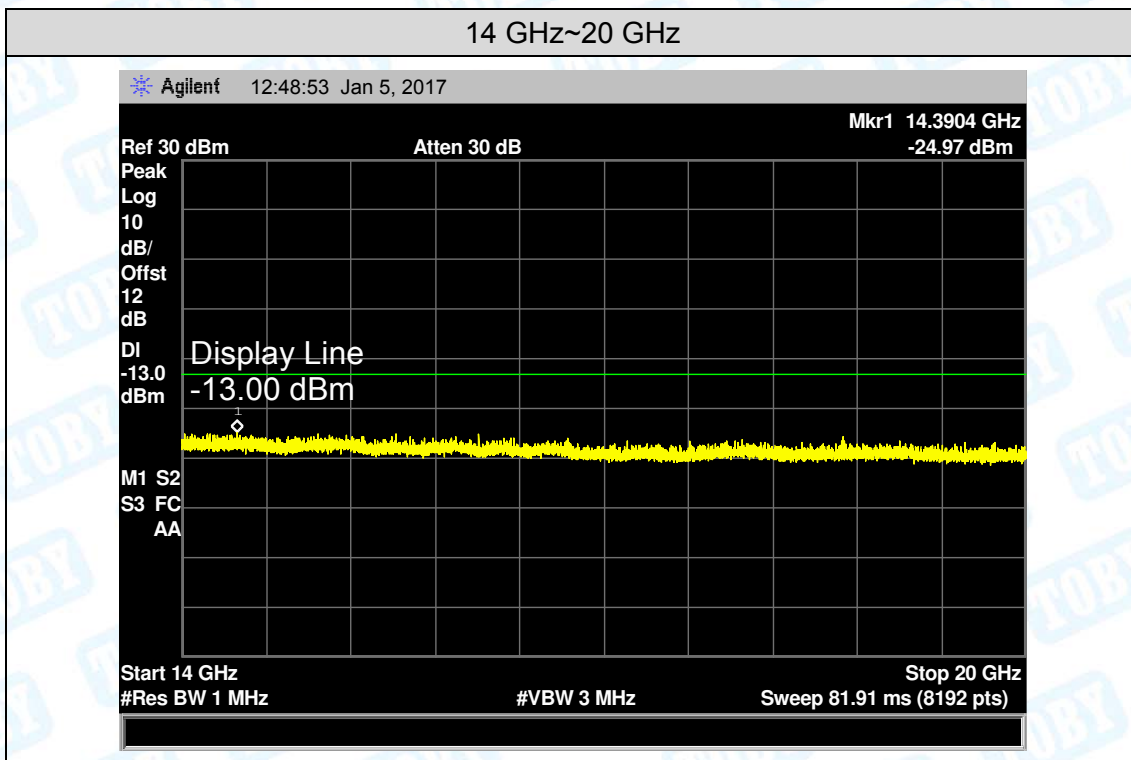

10. Band Edge Test

10.1 Test Standard and Limit

10.1.1 Test Standard

FCC Part 2: 2.1051, 2.1057

FCC Part 22H: 22.917(a)

FCC Part 24E: 24.238(a)

10.1.2 Test Limit

The power of any emission outside of the authorized operating frequency ranges must be attenuated below the transmitting power(P) by a factor of at least $43+10\log(P)$ dB. For all power levels +30 dBm to 0 dBm, this becomes a constant specification limit of -13 dBm.

10.2 Test Setup

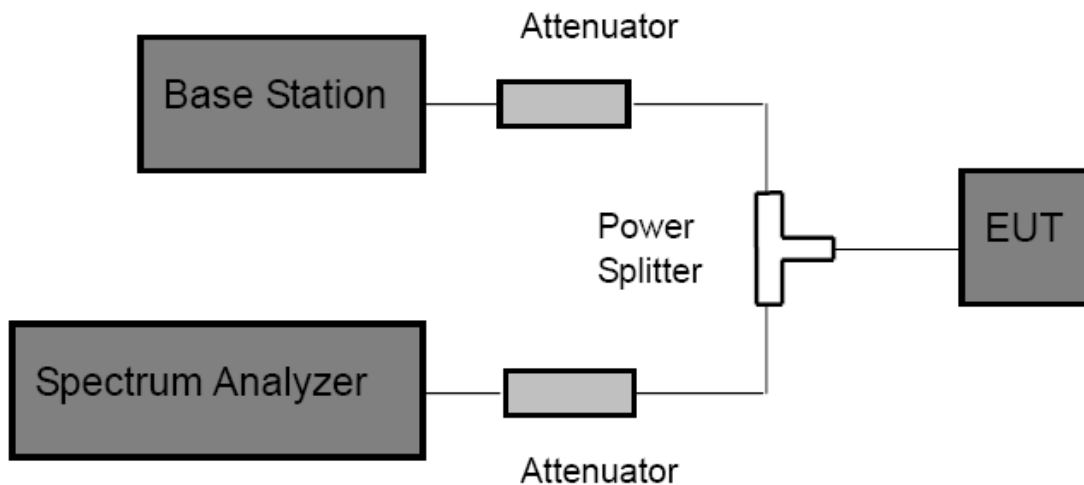

10.3 Test Procedure

- (1) The EUT was directly connected to the spectrum analyzer and Base station via power splitter as show in the block diagram above.
- (2) Spectrum Setting:
 - GSM and PCS: $RBW \geq 1\%$ 26db bandwidth, $VBW=3$ RBW, Span 1 MHz, Detector: Peak Mode.
 - WCDMA: $RBW \geq 1\%$ 26db bandwidth, $VBW=3$ RBW, Span 10 MHz, Detector: Peak Mode.
- (3) The band edges of low and high channels for the highest RF powers were measured.

10.4 EUT Operating Condition

The EUT was continuously connected with the Base station and transmitting in the max power during the test.

10.5 Test Data

Please refer the following plots:

Band edge emission:

Test Mode:	GPRS 850
------------	----------

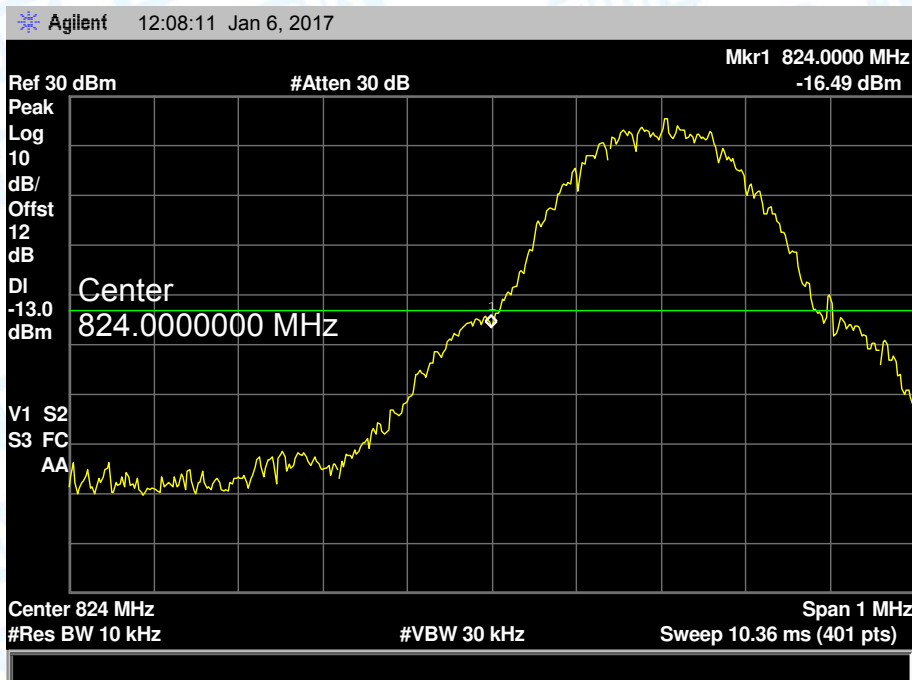

Lowest channel

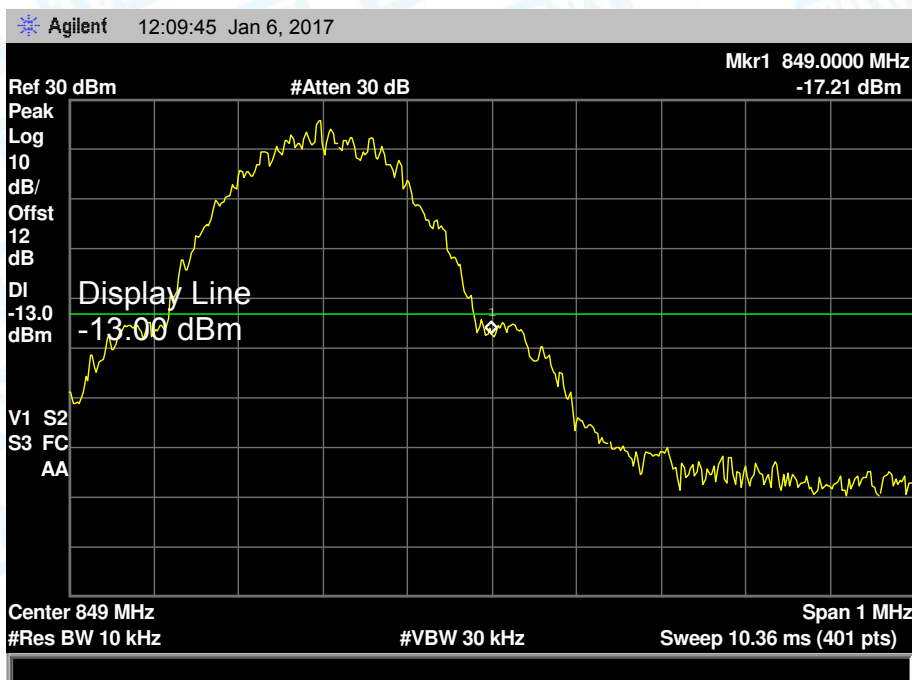

Highest channel

Test Mode: GPRS1900

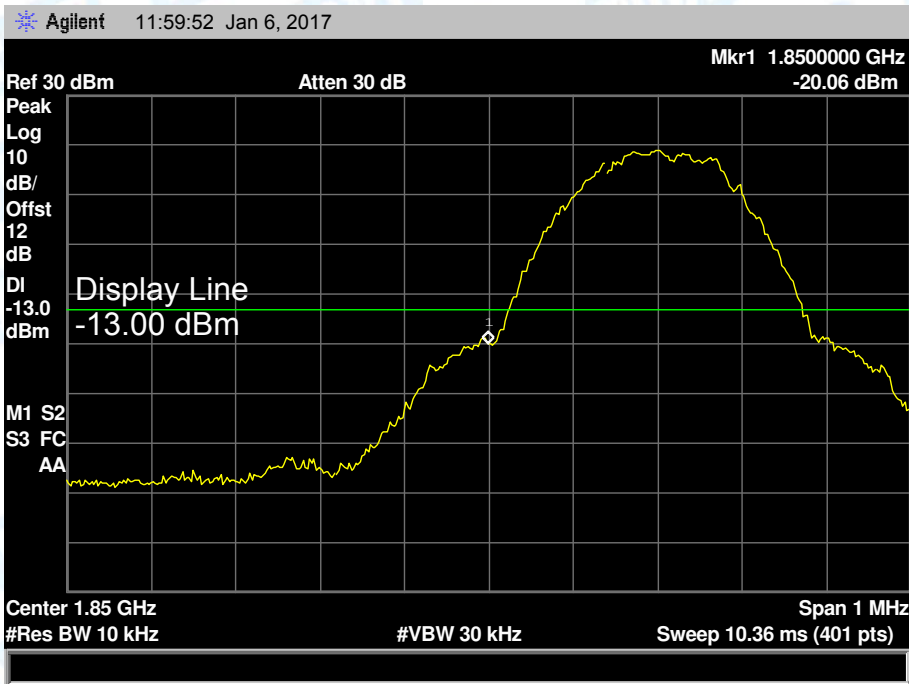

Lowest channel

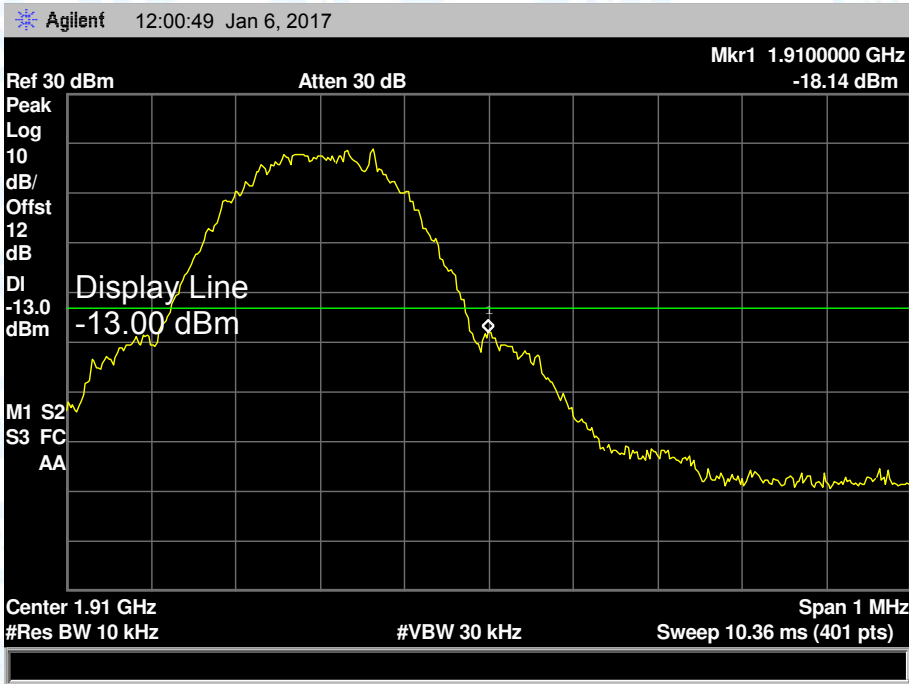

Highest channel

11. Radiated Out Band of Emissions

11.1 Test Standard and Limit

11.1.1 Test Standard

FCC Part 2: 2.1053, 2.1057

FCC Part 22H: 22.917

FCC Part 24E: 24.238

11.1.2 Test Limit

The power of any emission outside of the authorized operating frequency ranges must be attenuated below the transmitting power(P) by a factor of at least $43+10\log(P)$ dB. For all power levels +30 dBm to 0 dBm, this becomes a constant specification limit of -13 dBm.

11.2 Test Setup

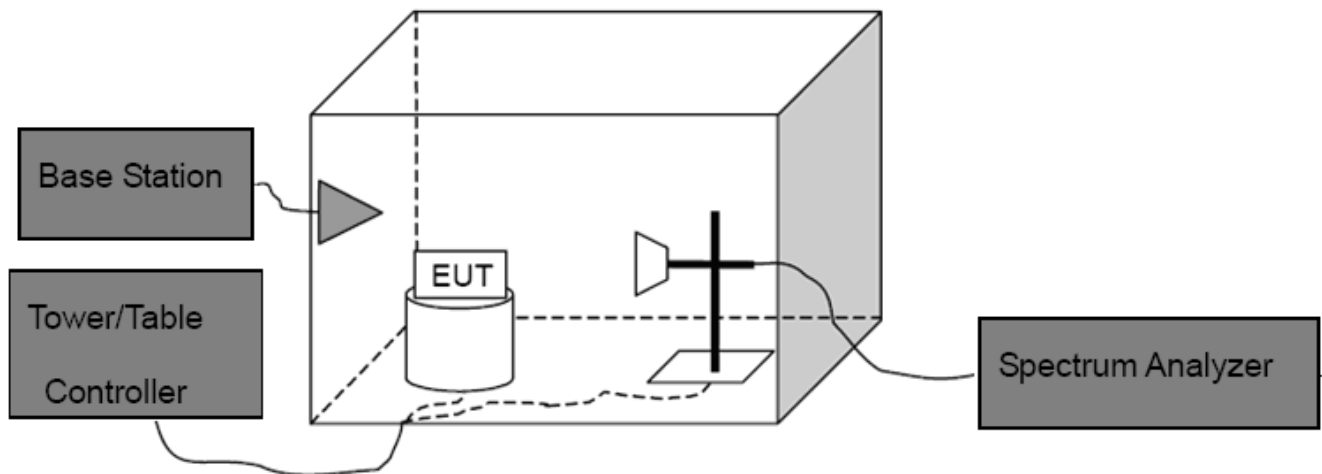

11.3 Test Procedure

- (1) The test system setup as show in the block diagram above.
- (2) The EUT was placed on an non-conductive rotating platform in an anechoic chamber. The radiated spurious emissions from 30MHz to 10th harmonious of fundamental frequency were measured at 3 m with a test antenna and a spectrum analyzer with RBW=1 MHz, VBW=1 MHz, peak detector settings.
- (3) During the measurement, the EUT was enforced in maximum power and linked with a base station. All the spurious emissions at 3m were measured by rotation of the turntable and the test antenna raised and lowered over a range from 1 to 4 meters in both horizontally and vertically polarized orientations.
- (4) When found the maximum level of emissions from the EUT. Remove the EUT and replace it with substitution antenna. A signal generator was connected to the substitution antenna by a non-radiating cable. The absolute levels of the spurious emissions were measured by the substitution.

Spurious emissions in dB=10 log(TX power in Watts/0.001)-the absolute level
Spurious attenuation limit in dB=43+10 log(power out in Watts)

11.4 EUT Operating Condition

The EUT was continuously connected with the Base station and transmitting in the max power during the test.

11.5 Test Data

Please refer the following pages.

Measurement Data (worst case)

Test mode:		GPRS 850						
Channel:		Middle			Date of Test:		2017-01-06	
Frequency (MHz)	Spurious Emission					Limit (dBm)	Result	
	Polarization (H&V)	Read Level (dBm)	Antenna Correct Factor (dBi)	Cable Loss (dB)	Emission Level (dBm)			
1673.20	Horizontal	-27.34	7.49	3.97	-16.34	-13.00	Pass	
2509.80	H	-37.96	7.03	5.05	-20.43			
3346.40	H	-43.62	12.48	5.98	-25.16			
4183.00	H	---	---	---	---			
5019.60	H	---	---	---	---			
5856.20	H	---	---	---	---			
1673.20	Vertical	-33.76	8.02	3.97	-19.32	-13.00	Pass	
2509.80	V	-43.54	10.47	5.05	-21.57			
3346.40	V	-47.40	16.92	5.98	-26.38			
4183.00	V	---	---	---	---			
5019.60	V	---	---	---	---			
5856.20	V	---	---	---	---			

Remark: 1, The testing has been conformed to $10 \times 836.6\text{MHz} = 8,366\text{MHz}$.
 2, All other emissions more than 30 dB below the limit.
 3, Emission Level= Read Level+ Antenna Correct Factor +Cable Loss

Test mode: GPRS 1900							
Channel: Middle			Date of Test: 2017-01-06				
Frequency (MHz)	Spurious Emission					Limit (dBm)	Result
	Polarization (H&V)	Read Level (dBm)	Antenna Correct Factor (dBi)	Cable Loss (dB)	Emission Level (dBm)		
3760.00	Horizontal	-35.50	14.70	6.12	-14.68	-13.00	Pass
5640.00	H	-41.26	13.67	7.86	-19.73		
7520.00	H	-46.48	14.27	9.54	-22.67		
9400.00	H	---	---	---	---		
11280.00	H	---	---	---	---		
13160.00	H	---	---	---	---	-13.00	Pass
3760.00	Vertical	-39.91	15.81	6.12	-17.98		
5640.00	V	-42.72	13.80	7.86	-21.06		
7520.00	V	-47.62	13.40	9.54	-24.68		
9400.00	V	---	---	---	---		
11280.00	V	---	---	---	---		
13160.00	V	---	---	---	---		

Remark: 1, The testing has been conformed to 10*1880.0MHz=18,800MHz.
 2, All other emissions more than 30 dB below the limit.
 3, Emission Level= Read Level+ Antenna Correct Factor +Cable Loss

-----END OF REPORT-----