

Quick Start Guide

⚠ WARNING

1. Please put on gloves while using photopolymer resin to avoid direct contact with hands.
2. To ensure the printing quality, please don't open the light shield unless it's necessary.
3. Unused photopolymer resin needs to be stored in a dark, dry, and cool place.
4. Please clean the finished model with anhydrous alcohol.
5. Please ensure that the platform is installed correctly and no items before operating to avoid damaging the LCD screen.

Foreword

Note Each 3D printer has undergone a printing test before leaving the factory. If there are residual consumables in the feed resin tank or slight scratches on the printing platform, it is normal and will not affect the use.

Dear customer:

Thank you for choosing and using the products of Flashforge Technology. Thank you for your great support and help. The product quality and performance of Flashforge Technology are excellent. For your convenience, please read the manual carefully before use, and strictly follow the instructions of the manual. The entire Flashforge Technology team is always ready to provide you with the best quality service. No matter what problems you encounter during use, please contact us according to the telephone and email provided at the end of the manual.

In order for you to experience our products better, you can also obtain equipment operating knowledge from the following channels:

Quick Starter Guide

Please unpack it carefully, you can take out the attached quick start guide from the top layer of foam. The quick start guide will help you get familiar with the device as quickly as possible and successfully complete the first printing experience.

Notice

Safety tips: Please make sure to read the following safety tips carefully

Work Environment Safety

- ◆ Keep your work place tidy.
- ◆ Do not operate in the presence of flammable liquids, gases or dust.
- ◆ Children and untrained personnel should not operate the equipment alone.

Environment Requirements

- ◆ Temperature: RT 15-30°C
- ◆ Moisture: 20%-70%

Place Requirements

- ◆ The device must be placed in a dry and ventilated environment. The distances of the left, right and back side space should be at least 20cm, and the distance of the front side space should be at least 35cm.

Electrical Requirements

- ◆ Be sure to ground the device; do not modify the plug of the device. (Ungrounded/incorrectly grounded/modified plugs will inevitably increase the risk of leakage)
- ◆ Do not expose the device to humidity and hot sun. (Wet environment will increase the risk of leakage/exposure will accelerate the aging of plastic parts)
- ◆ Do not abuse the power cord, and be sure to use the power cord provided by Flashforge.
- ◆ Do not use the device during thunderstorms. If you do not use the device for a long time, please turn off the device and unplug the power cord.

Personal Safety

- ◆ Please don't direct touch the photopolymer resin with hands.
- ◆ Please put on gloves and masks during operation.
- ◆ Please don't look at the light source directly.
- ◆ Do not operate the device while you are tired or under the influence of drugs, alcohol or medication.

Cautions

- ◆ Operate the device in a well-ventilated environment
- ◆ Do not leave the device unattended for long
- ◆ Do not make any modifications to the device
- ◆ Do not operate the device in bright light.
- ◆ Never use the device for illegal activities.
- ◆ Never use the device to make any food storage vessels.
- ◆ Never use the device to make any electrical appliance.
- ◆ Never put the model into your mouth.
- ◆ Do not remove the models with force.

Photopolymer Resin Requirements

- ◆ Please store the photosensitive resin solution in a dark and dry environment. Please place it in a place out of the reach of children. Please ensure that the label surface of the bottle is facing the eye-catching direction.

Photopolymer Resin Storage

- ◆ Unused photopolymer resin needs to be stored in a dark, dry, cool place, and out of the reach of children. Ensure the bottle body logo faces in an eye-catching and visible direction.

Legal Notice

- ◆ The user has no right to make any changes to this manual. Flashforge Technology will not be responsible for any safety accidents caused by customers disassembling or modifying the equipment by themselves. Without the permission of Flashforge no one may modify or translate this manual. This manual is protected by copyright, and Flashforge reserves the right of final interpretation of this manual.

First edition (March 2021)

@Copyright 2020 Zhejiang Flashforge 3D Technology Co.,Ltd., Ltd. All rights reserved

Getting To Know Your 3D Printer

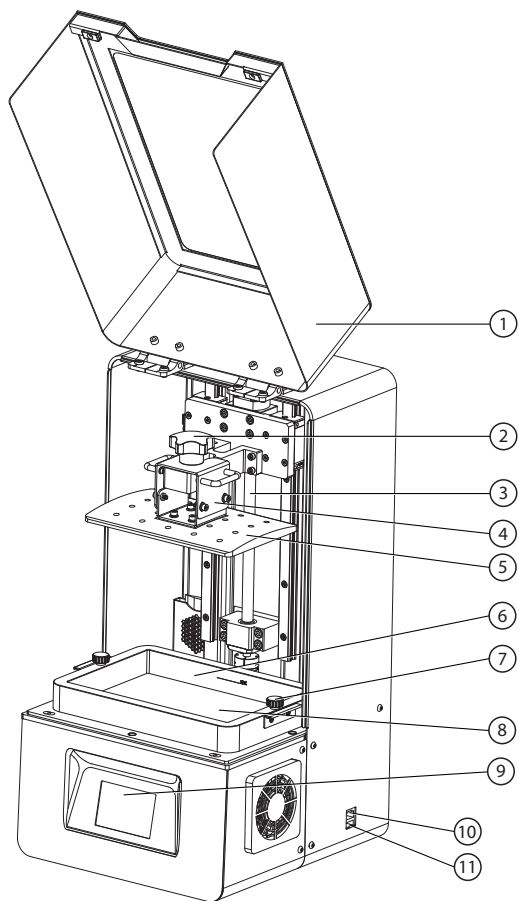

- 1. Light Shield 2. Platform Tighten Knob
- 3. Z-axis 4. Leveller 5. Build Plate
- 6. Resin Box 7. Box Tighten Knob 8. LCD
- 9. Touched Screen 10. Ethernet
- 11. USB Stick Port 12. Power Slot
- 13. Power switch

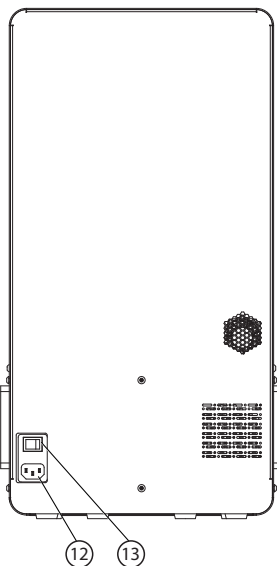

Accessory Box

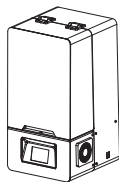

3D Printer



Power Cable

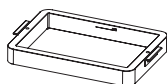

Resin Box



Quick Start Guide



After-sales card

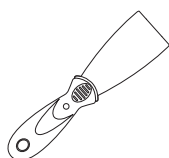

Metal Scraper

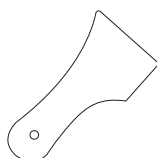

Plastic Scraper



Build plate set



Rubber Gloves

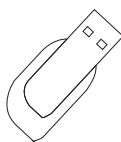

USB Stick



Wrench Set

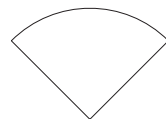

Filter Paper

Wrench Set: Stamping wrench, Screw driver, Screws

Build Plate set: Build plate, Leveller, Handle

Resin Box Set: Resin Box, FEP Film, Film fixed frame,
Box Tighten Knob

Leveling

Open the paper box and take out the 3D printer on the desk. Remove all protective foam and plug in the power cable.

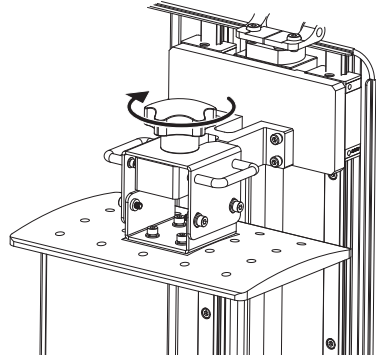
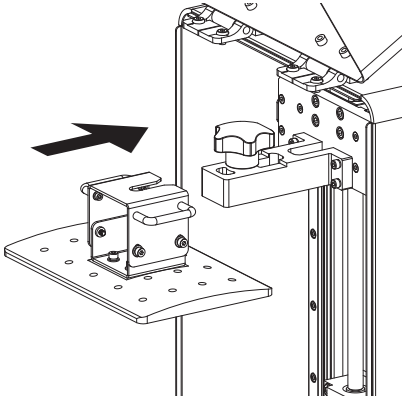

1. Install the build plate on the plate holder. 2. Tighten the platform tighten knob.

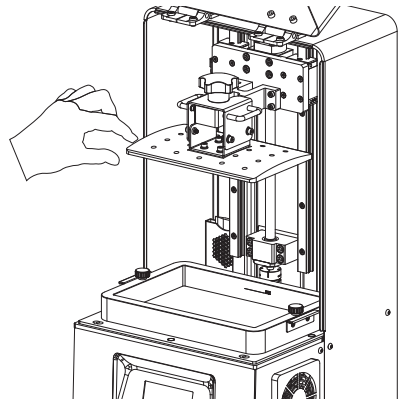
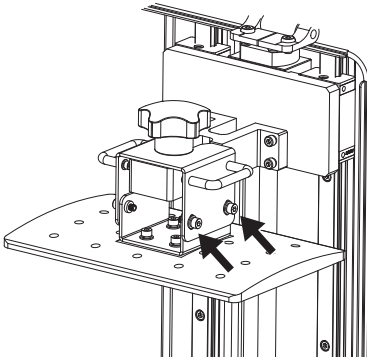

3. To loose the screws on both sides of the build plate by using an inner hex wrench.

4. Make sure it can move free but not to fall.

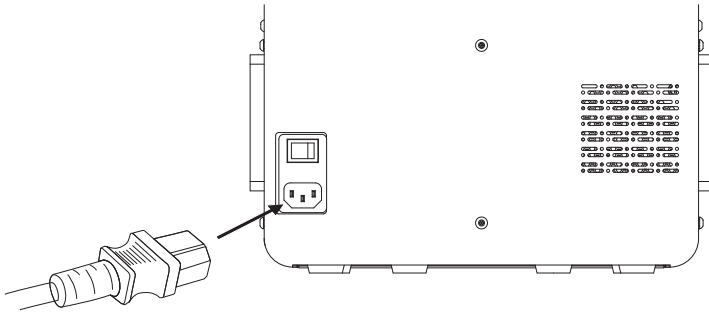

5. Connect the power adapter and power cable. Plug the output end of the power adapter into the power input port on the back of the printer and turn on the switch.

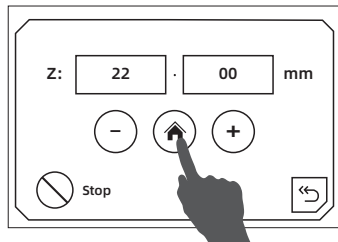
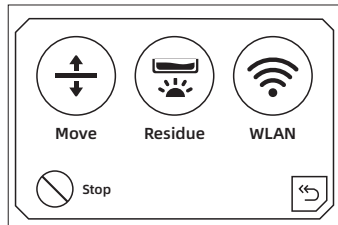
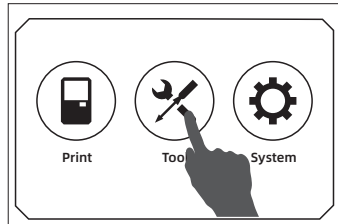
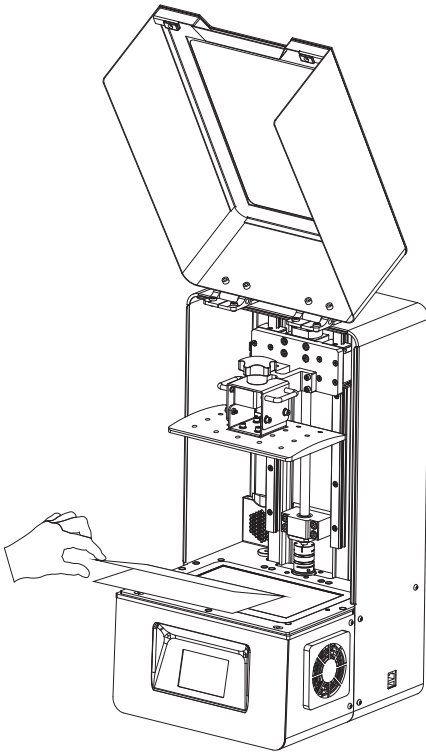

6. Remove resin box. Put a piece of A4 paper folded in half on the 8.9" LCD screen.

7. Click [Tool] - [Move] and open a new window. Click [Home] and wait for stop movement of Z-axis.

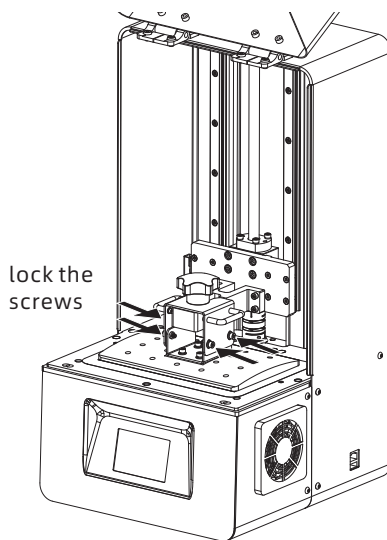
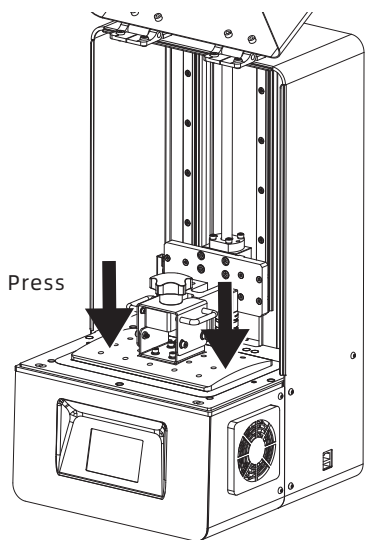

8. Press the top of the build plate with one hand to let four corners of build plate to touch the LCD screen evenly. Pre-tighten the screws on both sides of the platform and then lock them separately during the process. Twitch paper and feel the resistance.

- ◆ Notice: It must level for the first using. Suppose changing the new build plate and new screen, and it has to level again. It needs to level when the printing abnormal, such as the board on the side of the print model fell.

First Printing

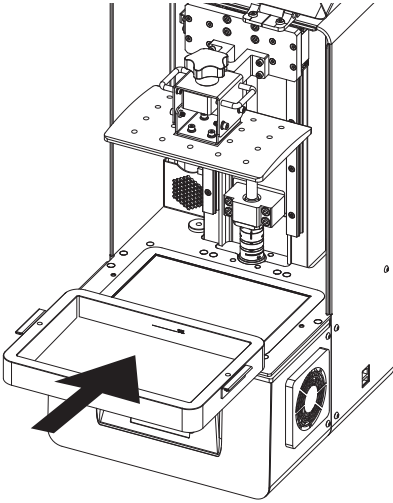

1. Make sure the LCD screen, build plate and resin box is clear enough. Install the resin box on the LCD screen.

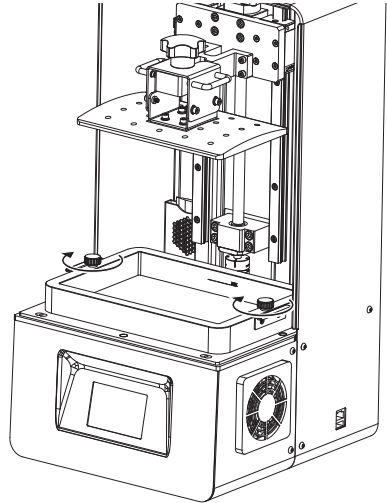

2. Tighten the knobs to fix the box.

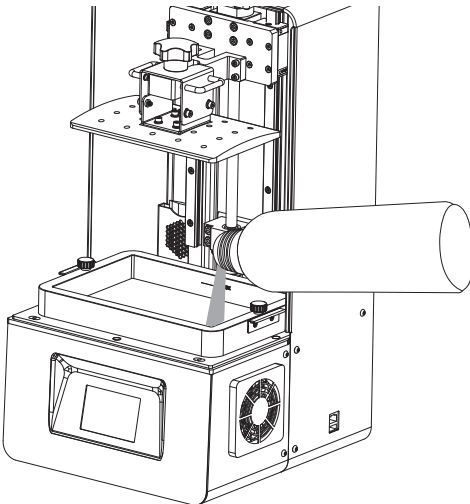

3. After confirm the installation of resin box and build plate, pour the resin into the resin box. Note that capacity shall not exceed the mark line in the resin box.

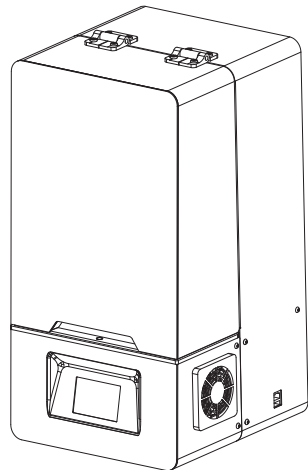

4. Close the light shield after all above preparatory steps.

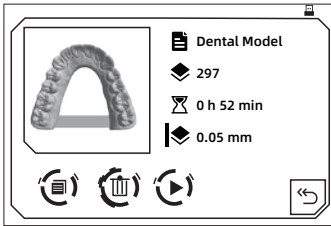
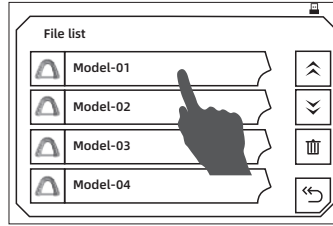
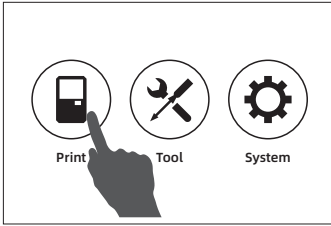

5. Click the [Print] to enter the model list. Click the model file to start the printing.

Note Do not open the top cover during printing to avoid eyes hurt.

Post-processing

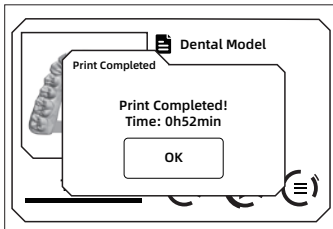

1. There will be a prompt on the touch screen when the printing is completed. Click [OK] and then open the top cover.

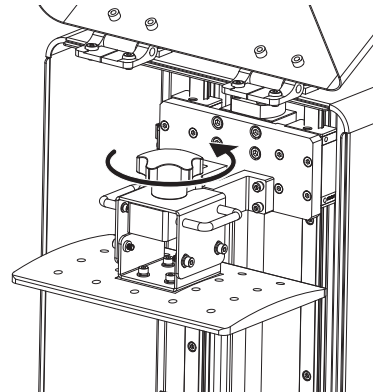

2. Loosen the nut to remove the build plate.
 ♦ Note: Be careful not to damage the FEP film in the resin box or the LCD screen during removal.

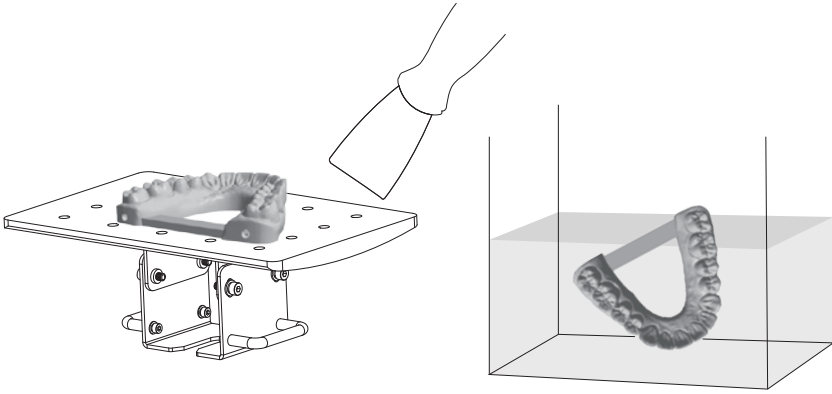

3. Remove the model via the metal scraper and clean the model in the cleaning box with anhydrous alcohol to wash off the excess resin.

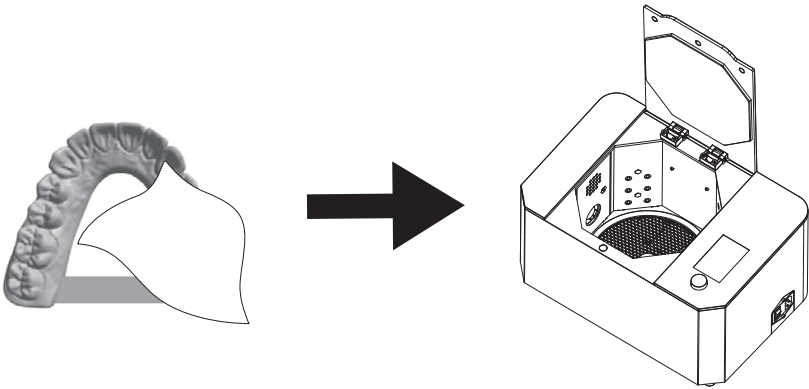

4. After cleaning, dry the model via a dust-free cloth or an air gun. It would be better to solidify the model again via curing box.

Note

During installation and removal of the build plate, please be extra careful to prevent the LCD screen from damage by build plate falling down.

- ◆ When the printing time is relatively long, please observe the printing regularly to avoid accidents and stop printing if the model is incomplete or dropped.
- ◆ Please make sure the printing environment keeps clean with less dust.
- ◆ Please confirm the installation and leveling gaps for several times when do the leveling if you are new to 3d printing.

Replace the FEP film in the resin box

Please refer to the following steps when install or replace the FEP film.

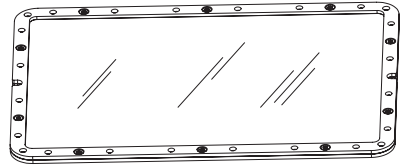
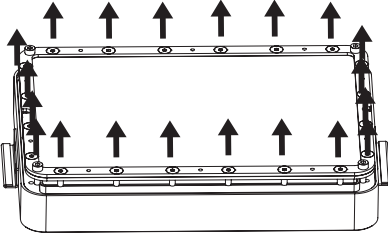

1. Loose the screws at the bottom of the resin box to remove the film fixing frame and remove the overused FEP film.

2. Align the FEP film with the screw holes and clamp it between the two fixing frames; then tighten the screws.

◆ Note: There are upper and lower sides of the frame; please verify the correct side through the screw holes.

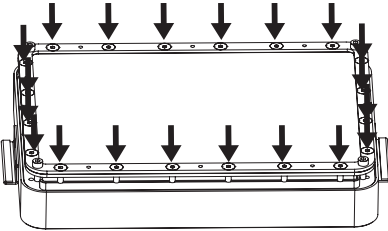

3. Re-install the film fixing frame to the bottom of the resin box and tighten the screws to make the FEP film tense. Then pour the water or resin into the resin box to check if there is leakage. Replace the FEP film and re-install it if there is.

◆ Note: please take care of the FEP film in the above steps to avoid damage and dirt.

Software Operation

FlashDental



FlashDental.exe



Load

1. Install and run the FlashDental.exe program.

2. Click Load, select the model file.

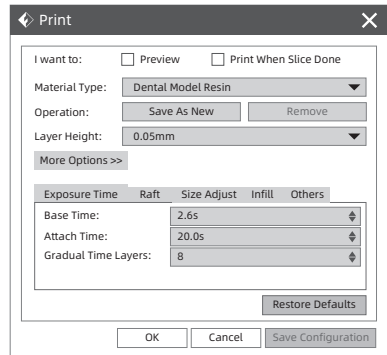
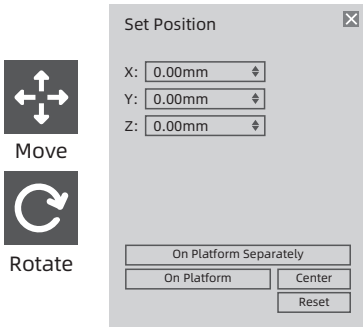

3. Use movement and rotation to place the model in an appropriate position. The model should not be lower than the network surface of the bottom plate.

4. Click Print, and a print window pops up. (Generally just adjust "layer thickness", "bottom number", "exposure time", "bottom exposure time", etc.)

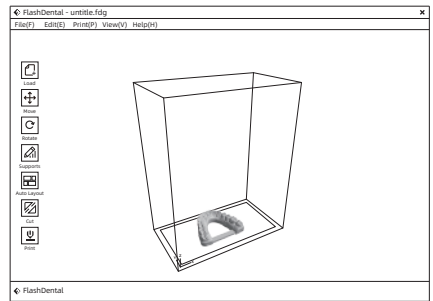
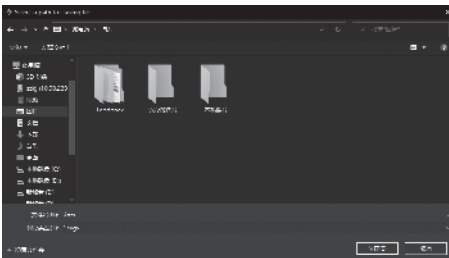

Slicing model ...

5. Click [OK], select the file type ".svgx", select the save location, and click [Save S].

6. At this point, "Slicing..." will be displayed at the bottom of the interface. , after the section is completed, the interface changes into the section preview interface.

Load the model files

1. Copy the '.svgx' file to the USB stick on the computer. It would be better to remove USB stick from computer after 'Safely Remove USB stick ' note to avoid file damage.

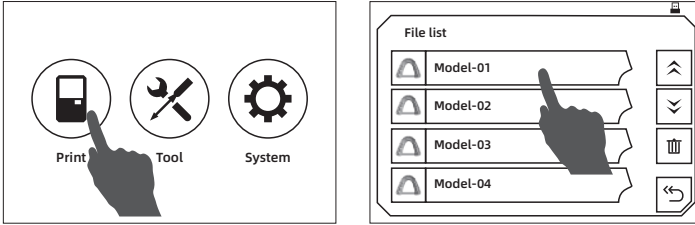

2. Insert USB stick into the USB stick port in the machine. Click [Print] on the screen to enter file list and scroll down your page to find the target model file. Please do not remove USB printing during printing.

Maintenance

- ◆ Please keep two parts shown in the picture below clear without dust and fingerprint.
- ◆ Do not pour the used residual resin back to the resin bottle.
- ◆ The waste resin can be poured into the sealing bag for sealing and then be exposed to the sun until the resin solidifies.
- ◆ If the resin drops onto the LCD screen, please wipe it with non-woven fabric in time; if the resin has solidified, please wipe it via non-woven fabric with alcohol.
- ◆ Do not clean the residual resin in the resin box with something sharp to avoid the damage of FEP film.
- ◆ If the print doesn't work for quite a long time, please pour the residual resin in the resin box into a closed container and keep it away from light. If a solidified model falls into the residual resin, please take it out as soon as possible.

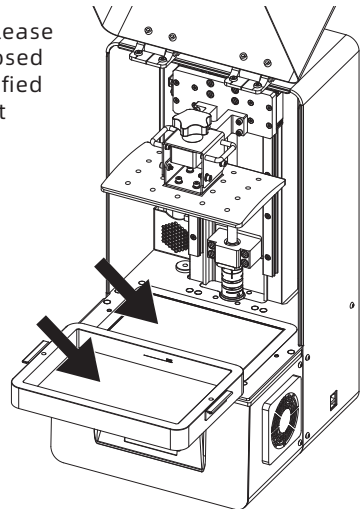



Follow us

Zhejiang Flashforge 3D Technology Co., Ltd.

Address: No.518 XianYuan Road, Jinhua City, Zhejiang Province, China

Service Hotline: +86 579 82273989

support@flashforge.com

FCC Statement

This device complies with part 15 of the FCC rules. Operation is subject to the following two conditions: (1) this device may not cause harmful interference, and (2) this device must accept any interference received, including interference that may cause undesired operation.

Changes or modifications not expressly approved by the party responsible for compliance could void the user's authority to operate the equipment.

NOTE: This equipment has been tested and found to comply with the limits for a Class B digital device, pursuant to part 15 of the FCC Rules. These limits are designed to provide reasonable protection against harmful interference in a residential installation. This equipment generates uses and can radiate radio frequency energy and, if not installed and used in accordance with the instructions, may cause harmful interference to radio communications. However, there is no guarantee that interference will not occur in a particular installation. If this equipment does cause harmful interference to radio or television reception, which can be determined by turning the equipment off and on, the user is encouraged to try to correct the interference by one or more of the following measures:

- Reorient or relocate the receiving antenna.
- Increase the separation between the equipment and receiver.
- Connect the equipment into an outlet on a circuit different from that to which the receiver is connected.
- Consult the dealer or an experienced radio/TV technician for help.

Radiation Exposure Statement

To comply with FCC RF exposure compliance requirements, this grant is applicable to only mobile configurations. The antennas used for this transmitter must be installed to provide a separation distance of at least 20cm from all persons and must not be co-located or operating in conjunction with any other antenna or transmitter.