

Certification Test Report

FCC ID: 2AKILBX050
IC: 22194-BX050

FCC Rule Part: 15.247
ISED Canada Radio Standards Specification: RSS-247

ACS Report Number: 16-2074.W06.1A

Applicant: Creed Monarch, Inc.

Model(s): BX050

Test Begin Date: **November 22, 2016**
Test End Date: **November 28, 2016**

Report Issue Date: January 3, 2017



FOR THE SCOPE OF ACCREDITATION UNDER CERTIFICATE NUMBER AT-1533

This report must not be used by the client to claim product certification, approval, or endorsement by ANAB, ANSI, or any agency of the Federal Government.

Prepared by:

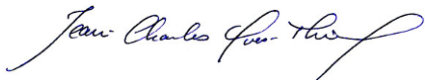

Thierry Jean-Charles
EMC Engineer
Advanced Compliance Solutions, Inc.

Reviewed by:



Ryan McGann
Wireless Program Manager
Advanced Compliance Solutions, Inc.

This test report shall not be reproduced except in full. This report may be reproduced in part with prior written consent of ACS, Inc. The results contained in this report are representative of the sample(s) submitted for evaluation.

This report contains 20 pages

TABLE OF CONTENTS

1	GENERAL	3
1.1	Purpose	3
1.2	Applicant Information	3
1.3	Product Description	3
1.4	Test Methodology and Considerations	3
2	TEST FACILITIES	4
2.1	Location	4
2.2	Laboratory Accreditations/Recognitions/Certifications.....	4
2.3	Radiated & Conducted Emissions Test Site Description	5
2.3.1	Semi-Anechoic Chamber Test Site	5
2.3.2	Conducted Emissions Test Site Description.....	6
3	APPLICABLE STANDARD REFERENCES	7
4	LIST OF TEST EQUIPMENT	8
5	SUPPORT EQUIPMENT	9
6	EQUIPMENT UNDER TEST SETUP BLOCK DIAGRAM	9
7	SUMMARY OF TESTS	10
7.1	Antenna Requirement – FCC: Section 15.203.....	10
7.2	6 dB Bandwidth - FCC: Section 15.247(a)(2); ISED Canada: RSS-247 5.2(1); 99% Bandwidth ISED Canada: RSS-GEN 6.6.....	10
7.2.1	Measurement Procedure.....	10
7.2.2	Measurement Results	10
7.3	Peak Output Power - FCC Section 15.247(b)(3); ISED Canada: RSS-247 5.4(4).....	12
7.3.1	Measurement Procedure (Conducted Method)	12
7.3.2	Measurement Results	12
7.4	Band-Edge and Spurious Emissions	13
7.4.1	Band-Edge Compliance of RF Conducted Emissions - FCC Section 15.247(d); ISED Canada: RSS-247 5.5.....	13
7.4.1.1	Measurement Procedure.....	13
7.4.1.2	Measurement Results	13
7.4.2	RF Conducted Spurious Emissions - FCC Section 15.247(d); ISED Canada: RSS-247 5.5.....	15
7.4.2.1	Measurement Procedure.....	15
7.4.2.2	Measurement Results	15
7.4.3	Radiated Spurious Emissions into Restricted Frequency Bands – FCC Sections 15.205, 15.209; ISED Canada: RSS-Gen 8.9, 8.10	16
7.4.3.1	Measurement Procedure.....	16
7.4.3.2	Duty Cycle Correction	16
7.4.3.3	Measurement Results	16
7.4.3.4	Sample Calculation:	18
7.5	Power Spectral Density - FCC Section 15.247(e); ISED Canada: RSS-247 5.2(2)	19
7.5.1	PSD Measurement Procedure (Conducted Method).....	19
7.5.2	Measurement Results	19
8	CONCLUSION	20

1 GENERAL

1.1 Purpose

The purpose of this report is to demonstrate compliance with Part 15 Subpart C of the FCC's Code of Federal Regulations and Innovation, Science and Economic Development Canada's Radio Standards Specification RSS-247 for the tests documented herein.

1.2 Applicant Information

Creed Monarch, Inc.
P O Box 550
New Britain, CT 06050 USA

1.3 Product Description

The Creed Monarch, Inc. Patriot II remote model BX050 is a 12Volt RV battery powered Remote for RV supplemental Brake. Remote unit is coupled to Brake unit residing in towed car with two-way RF radio link. The equipment operates in the 900 MHz ISM band. The device also includes a 433 MHz Tire Pressure Monitor System receiver.

Technical Details

Mode of Operation: LoRa
Frequency Range: 922.4 MHz
Number of Channels: 1
Channel Separation: N/A
Modulations: CSS
Antenna Type/Gain: Helical SMD Antenna/ 0.8 dBi
Input Power: 12 VDC

Model Number: BX050

Test Sample Serial Number(s): ACS#2

Test Sample Condition: The equipment was provided in good condition without any physical damage.

1.4 Test Methodology and Considerations

The 922.4 MHz LoRa transceiver was evaluated for radiated and RF conducted emissions. The test power setting is not provided and is not configurable via software. The EUT is for vehicle implementation only with no provision for connection to the AC Mains. The EUT is exempted from the power line conducted emissions requirements.

For the emissions evaluation, the EUT set in three orthogonal orientations while powered by a DC power supply.

The RF conducted emissions evaluation was performed on a sample modified with an SMA connector at the antenna port.

The EUT was also investigated for unintentional emissions. The results are documented separately in a verification test report.

2 TEST FACILITIES

2.1 Location

The radiated and conducted emissions test sites are located at the following address:

Advanced Compliance Solutions, Inc.
3998 FAU Blvd, Suite 310
Boca Raton, Florida 33431
Phone: (561) 961-5585
Fax: (561) 961-5587
www.acstestlab.com

FCC Test Firm Registration #: 475089
Innovation, Science and Economic Development Canada Lab Code: 4175C

2.2 Laboratory Accreditations/Recognitions/Certifications

ACS is accredited to ISO/IEC 17025 by ANSI-ASQ National Accreditation Board under their ANAB program and has been issued certificate number AT-1533 in recognition of this accreditation. Unless otherwise specified, all test methods described within this report are covered under the ISO/IEC 17025 scope of accreditation.

2.3 Radiated & Conducted Emissions Test Site Description

2.3.1 Semi-Anechoic Chamber Test Site

The EMC radiated test facility consists of an RF-shielded enclosure. The interior dimensions of the indoor semi-anechoic chamber are approximately 48 feet (14.6 m) long by 36 feet (10.8 m) wide by 24 feet (7.3 m) high and consist of rigid, 1/8 inch (0.32 cm) steel-clad, wood core modular panels with steel framing. In the shielded enclosure, the faces of the panels are galvanized and the chamber is self-supporting. 8-foot RF absorbing cones are installed on 4 walls and the ceiling. The steel-clad ground plane is covered with vinyl flooring.

The turntable is driven by pneumatic motor, which is capable of supporting a 2000 lb. load. The turntable is flush with the chamber floor which it is connected to, around its circumference, with a continuous metallic loaded spring. An EMCO Model 1060 Multi-device controller controls the turntable position.

A pneumatic motor is used to control antenna polarizations and height relative to the ground. The height information is displayed on the control unit EMCO Model 1050.

The control room is an RF shielded enclosure attached to the semi-anechoic chamber with two bulkhead panels for connecting RF, and control cables. The dimension of the room is 7.3 m x 4.9 m x 3 m high and the entrance doors of both control and conducted rooms are 3 feet (0.91 m) by 7 feet (2.13 m).

A diagram of the Semi-Anechoic Chamber Test Site is shown in Figure 2.3.1-1 below:

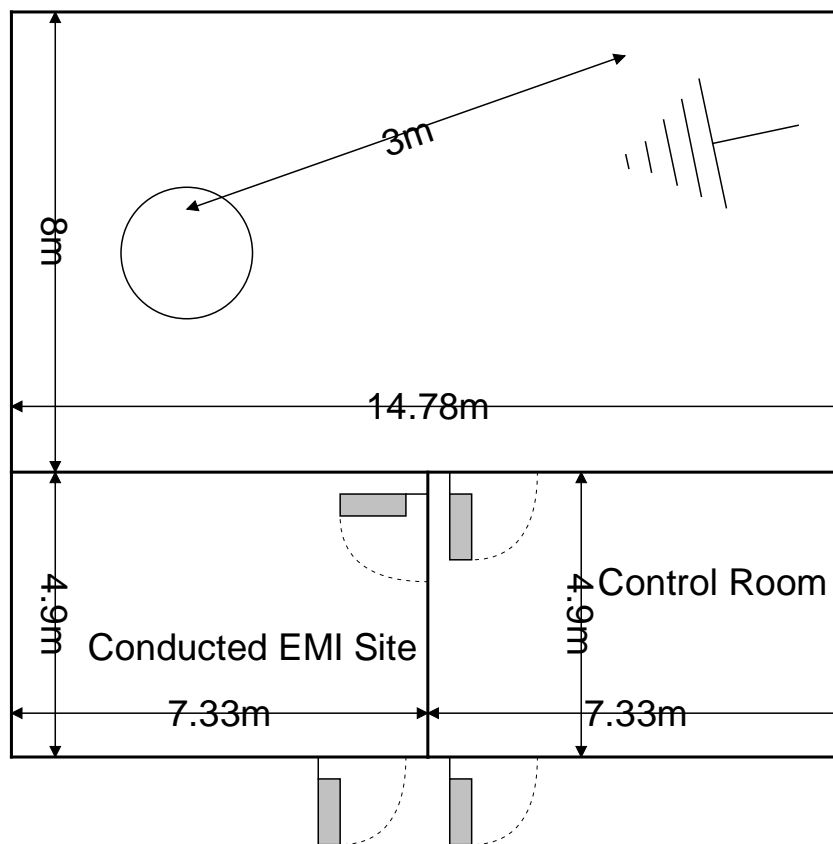

Figure 2.3.1-1: Semi-Anechoic Chamber Test Site

2.3.2 Conducted Emissions Test Site Description

The dimensions of the shielded conducted room are 7.3 x 4.9 x 3 m³. The power line conducted emission site includes two LISNs: a Solar Model 8028-50 50 Ω/50 μH and an EMCO Model 3825/2R, which are installed as shown in the figure below. For evaluations requiring 230 V, 50 Hz AC input, a Polarad LISN (S/N 879341/048) is used in conjunction with a California Instruments signal generator Model 2001RP-OP1.

A diagram of the room is shown below in figure 2.3.2-1:

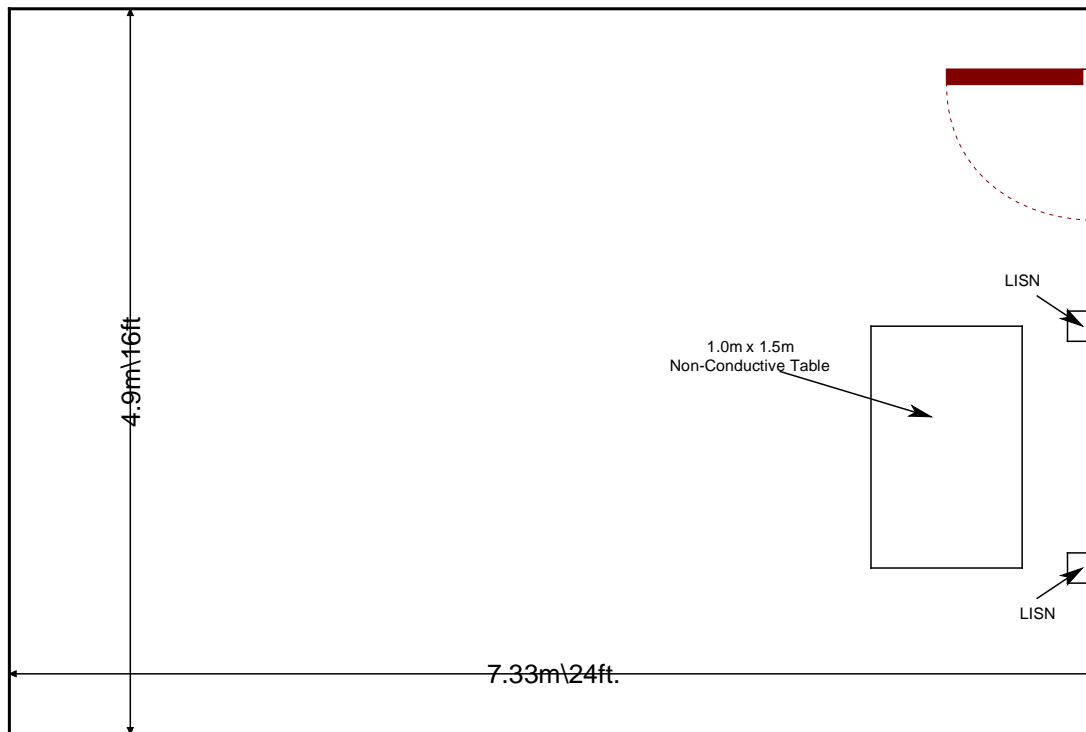

Figure 2.3.2-1: AC Mains Conducted EMI Site

3 APPLICABLE STANDARD REFERENCES

The following standards were used:

- ❖ ANSI C63.4-2014: Method of Measurements of Radio-Noise Emissions from Low-Voltage Electrical and Electronic Equipment in the 9 kHz to 40 GHz.
- ❖ ANSI C63.10-2013: American National Standard of Procedures for Compliance Testing of Unlicensed Wireless Devices
- ❖ US Code of Federal Regulations (CFR): Title 47, Part 2, Subpart J: Equipment Authorization Procedures, 2016.
- ❖ US Code of Federal Regulations (CFR): Title 47, Part 15, Subpart C: Radio Frequency Devices, Intentional Radiators, 2016
- ❖ FCC KDB 558074 D01 DTS Meas Guidance v03r05 - Guidance for Performing Compliance Measurements on Digital Transmission Systems (DTS) Operating Under §15.247, April 8, 2016.
- ❖ Innovation, Science and Economic Development Canada Radio Standards Specification: RSS-247 — Digital Transmission Systems (DTSS), Frequency Hopping Systems (FHSs) and Licence-Exempt Local Area Network (LE-LAN) Devices, Issue 1, May 2015.
- ❖ Innovation, Science and Economic Development Canada Radio Standards Specification: RSS-GEN – General Requirements for Compliance of Radio Apparatus, Issue 4, November 2014.

4 LIST OF TEST EQUIPMENT

The calibration interval of test equipment is annually or the manufacturer's recommendations. Where the calibration interval deviates from the annual cycle based on the instrument manufacturer's recommendations, it shall be stated below.

Table 4-1: Test Equipment List

AssetID	Manufacturer	Model #	Equipment Type	Serial #	Last Calibration Date	Calibration Due Date
22	Agilent	8449B	Amplifiers	3008A00526	7/14/2016	7/14/2018
78	EMCO	6502	Antennas	9104-2608	5/11/2016	5/11/2018
283	Rohde & Schwarz	FSP40	Spectrum Analyzers	1000033	7/21/2016	7/21/2018
523	Agilent	E7405	Spectrum Analyzers	MY45103293	12/26/2014	12/26/2016
2002	EMCO	3108	Antennas	2147	11/19/2015	11/19/2017
2004	EMCO	3146	Antennas	1385	11/19/2015	11/19/2017
2006	EMCO	3115	Antennas	2573	4/14/2015	4/14/2017
2011	Hewlett-Packard	HP 8447D	Amplifiers	2443A03952	11/2/2016	11/2/2017
2071	Trilithic, Inc.	4HC1400-1-KK	Filter	9643263	11/1/2016	11/1/2017
2086	Merrimac	FAN-6-10K	Attenuators	23148-83-1	11/2/2016	11/2/2017
2095	ETS Lindgren	TILE4! - Version 4.2.A	Software	85242	NCR	NCR
2111	Aeroflex Inmet	40AH2W-20	Attenuator	2111	7/20/2016	7/20/2017
2112	Teledyne Storm Products	921-0101-036	Cables	12-06-698	11/2/2016	11/2/2017
2121	ACS Boca	Radiated Cable Set	Cable Set	2121	8/1/2016	8/1/2017

Note: NCR=No Calibration Required

5 SUPPORT EQUIPMENT

Table 5-1: EUT and Support Equipment Description

Item #	Type Device	Manufacturer	Model/Part #	Serial #
1	EUT	Creed Monarch	BX050	ACS#2
2	Cigarette Lighter Plug	Creed Monarch	N/A	ACS#3
3	DC Power Supply	MPJA	HY5003	003700278

Table 5-2: Cable Description

Cable #	Cable Type	Length	Shield	Termination
A	Power cable	3 m	No	EUT to Cigarette Lighter Plug
B	2-Wire Power Leads	1.95 m	No	Cigarette Lighter Plug to Power Supply
C	MPJA Power Cable	1.8 m	No	Power Supply to AC Mains

6 EQUIPMENT UNDER TEST SETUP BLOCK DIAGRAM

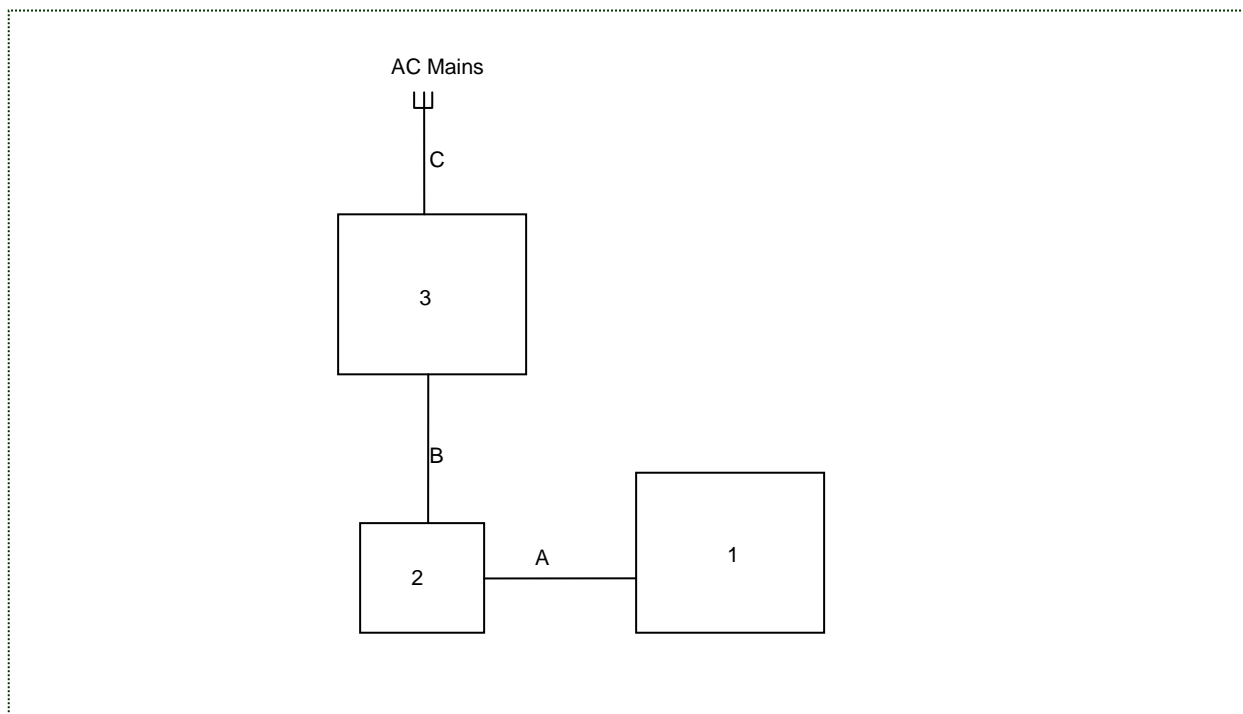

Figure 6-1: EUT Test Setup

7 SUMMARY OF TESTS

Along with the tabular data shown below, plots were taken of all signals deemed important enough to document.

7.1 Antenna Requirement – FCC: Section 15.203

The EUT uses an integral 0.8 dBi helical SMD antenna which is directly soldered to the PCB. The antenna is not removable and therefore meets the requirements of FCC Section 15.203.

7.2 6 dB Bandwidth - FCC: Section 15.247(a)(2); ISED Canada: RSS-247 5.2(1); 99% Bandwidth ISED Canada: RSS-GEN 6.6

7.2.1 Measurement Procedure

The 6dB bandwidth was measured in accordance with the FCC KDB 558074 D01 DTS Meas Guidance v03r05 Section 8.2 Option 2. The RBW of the spectrum analyzer was set to 100 kHz and VBW 300 kHz. Span was set large enough to capture the emissions and >> RBW.

The 99% occupied bandwidth was measured with the spectrum analyzer span set to fully display the emission. The RBW was set to 1% to 5% of the approximated bandwidth. The occupied 99% bandwidth was measured by using 99% bandwidth equipment function of the spectrum analyzer.

7.2.2 Measurement Results

Results are shown below.

Table 7.2.2-1: 6dB / 99% Bandwidth

Frequency [MHz]	6dB Bandwidth [kHz]	99% Bandwidth [kHz]
922.4	762.00	616.00

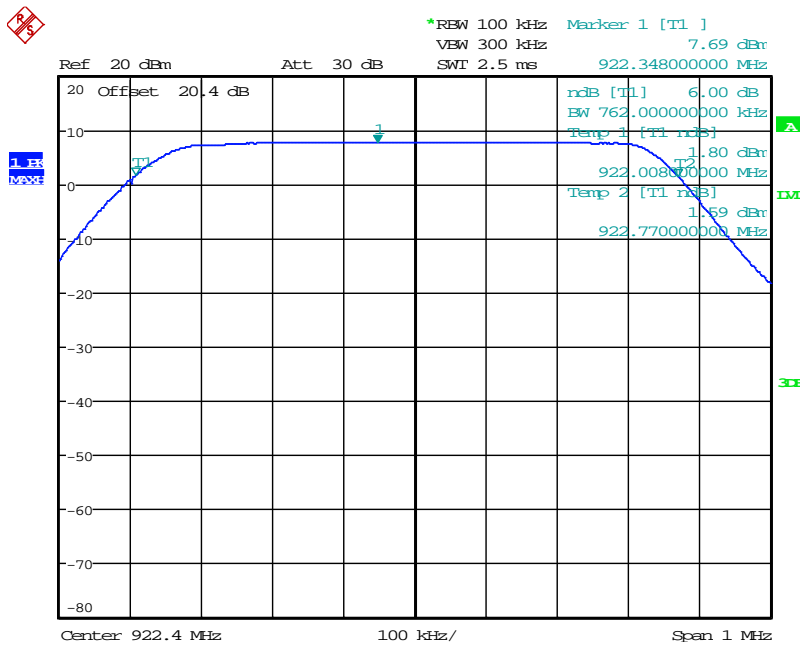

Date: 22.NOV.2016 13:27:38

Figure 7.2.2-1: 6dB BW

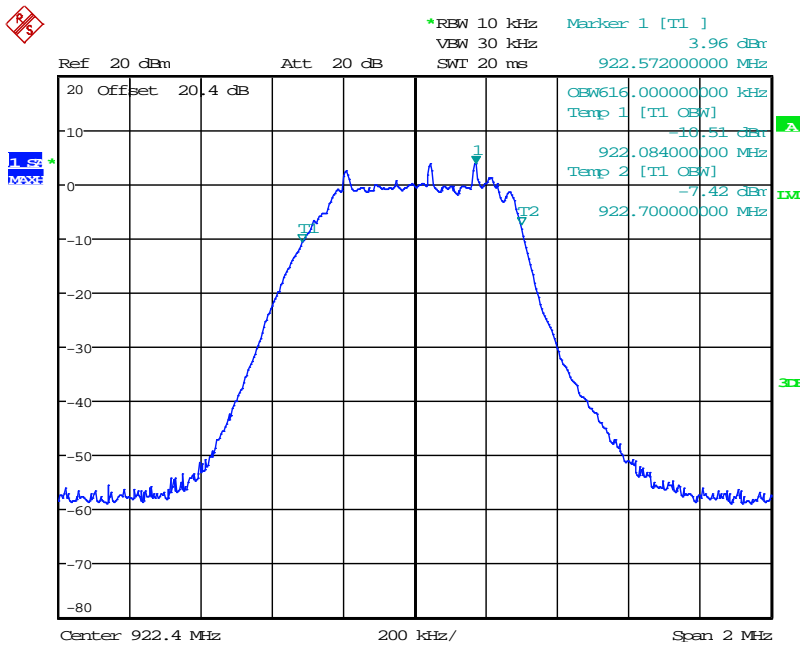

Date: 22.NOV.2016 13:40:09

Figure 7.2.2-2: 99% OBW

7.3 Peak Output Power - FCC Section 15.247(b)(3); ISED Canada: RSS-247 5.4(4)

7.3.1 Measurement Procedure (Conducted Method)

The fundamental emission output power was measured in accordance with the FCC KDB 558074 D01 DTS Meas Guidance v03r05 Section 9.1.1 RBW \geq DTS bandwidth. The RF output of the equipment under test was directly connected to the input of the spectrum analyzer through suitable attenuation.

7.3.2 Measurement Results

Results are shown below.

Table 7.3.2-1: RF Output Power

Frequency [MHz]	Level [dBm]
922.4	7.92

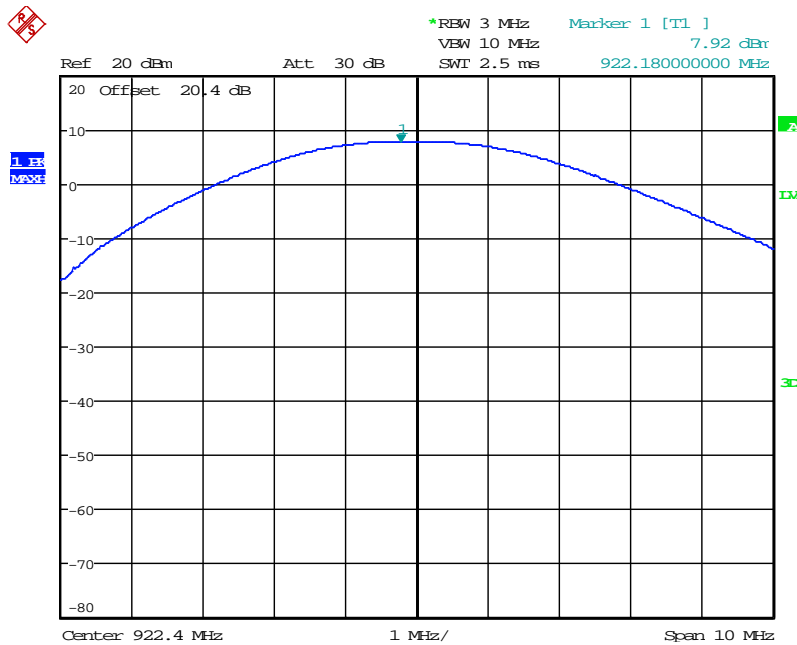

Date: 22.NOV.2016 13:33:28

Figure 7.3.2-1: RF Output Power

7.4 Band-Edge and Spurious Emissions

7.4.1 Band-Edge Compliance of RF Conducted Emissions - FCC Section 15.247(d); ISED Canada: RSS-247 5.5

7.4.1.1 Measurement Procedure

The RF output port of the EUT was directly connected to the input of the spectrum analyzer via suitable attenuation. The EUT was investigated at the transmitting channel to determine band-edge compliance. For each measurement the spectrum analyzer's RBW was set to 100 kHz, and the VBW was set to 300 kHz.

7.4.1.2 Measurement Results

Results are shown below.

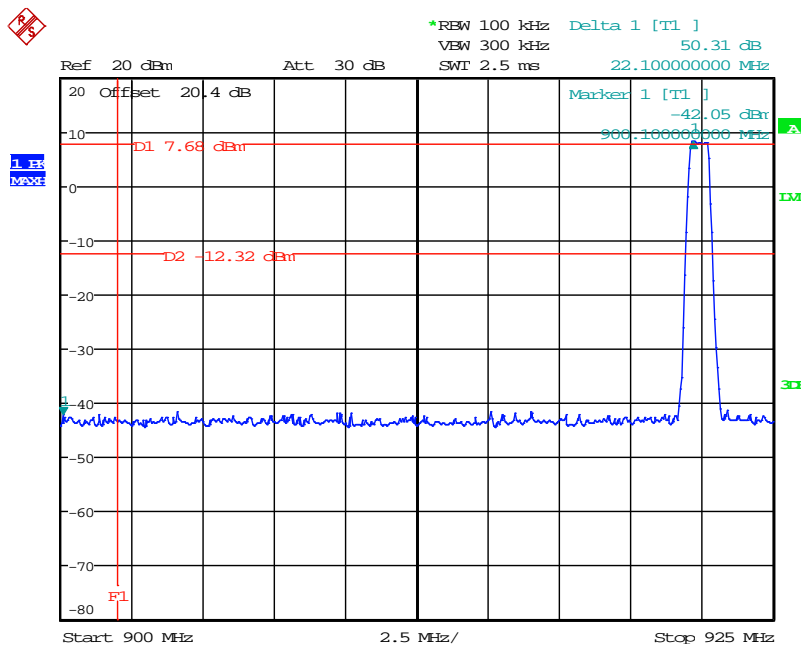

Date: 26.NOV.2016 19:29:59

Figure 7.4.1.2-1: Lower Band-edge

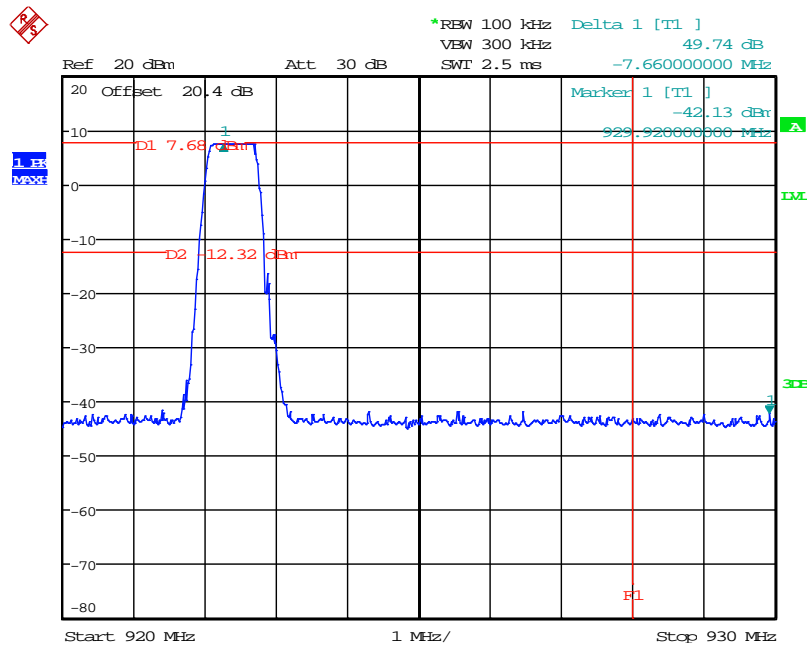

Date: 26.NOV.2016 19:31:25

Figure 7.4.1.2-2: Upper Band-edge

7.4.2 RF Conducted Spurious Emissions - FCC Section 15.247(d); ISED Canada: RSS-247 5.5

7.4.2.1 Measurement Procedure

The RF Conducted Spurious Emissions were measured in accordance with the FCC KDB 558074 D01 DTS Meas Guidance v03r05 Section 11.3 Emission level measurement. The RF output port of the equipment under test was directly connected to the input of the spectrum analyzer. The EUT was investigated for conducted spurious emissions from 30MHz to 10 GHz, 10 times the highest fundamental frequency. The spectrum analyzer's RBW was set to 100 kHz and the VBW was set to 300 kHz. The peak Max Hold function of the analyzer was utilized. The reference level was determined by measuring the Peak PSD level in any 100 kHz bandwidth within the DTS channel bandwidth.

7.4.2.2 Measurement Results

Results are shown below.

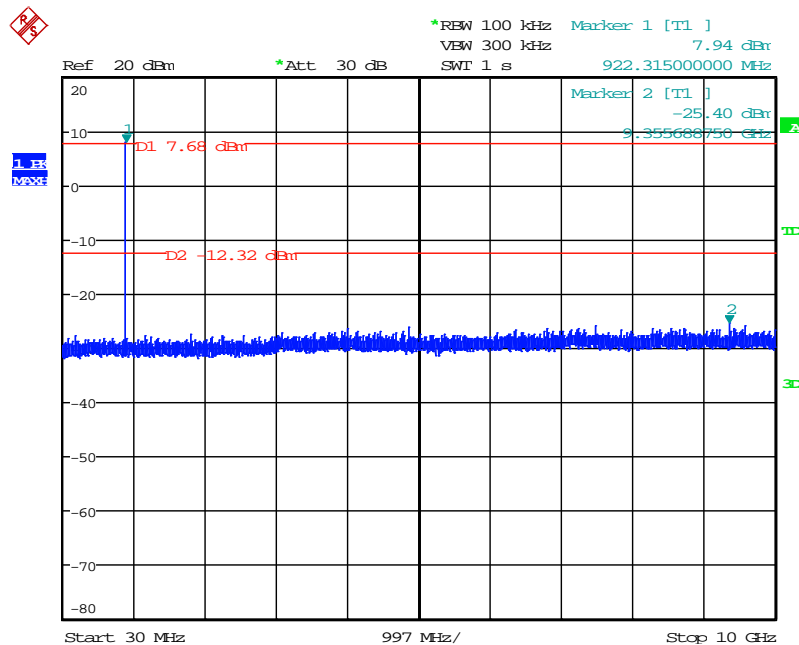

Date: 22.NOV.2016 13:45:04

Figure 7.4.2.2-1: 30 MHz – 10 GHz

7.4.3 Radiated Spurious Emissions into Restricted Frequency Bands – FCC Sections 15.205, 15.209; ISED Canada: RSS-Gen 8.9, 8.10

7.4.3.1 Measurement Procedure

Radiated emissions tests were made over the frequency range of 9 kHz to 10 GHz, 10 times the highest fundamental frequency. Each emission found to be in a restricted band as defined by section 15.205, including any emission at the operational band-edge, was compared to the radiated emission limits as defined in Section 15.209.

For measurements below 30 MHz, the receive antenna height was set to 1m and the EUT was rotated through 360 degrees. The resolution bandwidth was set to 200 Hz below 150 kHz and to 9 kHz above 150 kHz.

The EUT was rotated through 360° and the receive antenna height was varied from 1m to 4m so that the maximum radiated emissions level would be detected. For frequencies below 1000MHz, quasi-peak measurements were made using a resolution bandwidth RBW of 120 kHz and a video bandwidth VBW of 300 kHz. For frequencies above 1000 MHz, peak measurements are made with RBW of 1 MHz and VBW of 3 MHz. Average measurements are performed in the linear scale using VBW of 30 Hz.

7.4.3.2 Duty Cycle Correction

The average measurements were further corrected using a duty cycle correction factor corresponding to $20 \cdot \log(14/100) = -17.08$ dB. Justification for the duty cycle of the transceiver is provided in the Theory of Operation of the device.

7.4.3.3 Measurement Results

Radiated band-edge and spurious emissions found in the restricted frequency bands of 9 kHz to 10 GHz are reported in the tables below.

Table 7.4.3.3-1: Radiated Spurious Emissions Tabulated Data

Frequency (MHz)	Level (dBuV)		Antenna Polarity (H/V)	Correction Factors (dB)	Corrected Level (dBuV/m)		Limit (dBuV/m)		Margin (dB)	
	pk	Qpk/Avg			pk	Qpk/Avg	pk	Qpk/Avg	pk	Qpk/Avg
Flat										
2767.2	55.61	50.29	H	1.79	57.40	35.00	74.0	54.0	16.6	19.0
2767.2	52.53	46.76	V	1.79	54.32	31.47	74.0	54.0	19.7	22.5
3689.6	49.68	41.89	H	5.29	54.97	30.10	74.0	54.0	19.0	23.9
3689.6	48.14	39.88	V	5.29	53.43	28.09	74.0	54.0	20.6	25.9
4612	49.90	40.31	H	7.06	56.96	30.30	74.0	54.0	17.0	23.7
4612	48.76	39.38	V	7.06	55.82	29.37	74.0	54.0	18.2	24.6
7379.2	58.61	47.03	H	12.96	71.57	42.91	74.0	54.0	2.4	11.1
7379.2	59.86	48.29	V	12.96	72.82	44.17	74.0	54.0	1.2	9.8
8301.6	54.20	41.61	H	13.63	67.83	38.16	74.0	54.0	6.2	15.8
8301.6	53.39	40.75	V	13.63	67.02	37.30	74.0	54.0	7.0	16.7
Standing										
2767.2	54.71	50.23	H	1.79	56.50	34.94	74.0	54.0	17.5	19.1
2767.2	50.00	44.96	V	1.79	51.79	29.67	74.0	54.0	22.2	24.3
3689.6	49.93	43.76	H	5.29	55.22	31.97	74.0	54.0	18.8	22.0
3689.6	47.35	40.59	V	5.29	52.64	28.80	74.0	54.0	21.4	25.2
4612	46.36	37.57	H	7.06	53.42	27.56	74.0	54.0	20.6	26.4
4612	49.70	43.21	V	7.06	56.76	33.20	74.0	54.0	17.2	20.8
7379.2	55.39	46.70	H	12.96	68.35	42.58	74.0	54.0	5.7	11.4
7379.2	55.05	46.18	V	12.96	68.01	42.06	74.0	54.0	6.0	11.9
8301.6	49.81	39.16	H	13.63	63.44	35.71	74.0	54.0	10.6	18.3
8301.6	53.24	43.50	V	13.63	66.87	40.05	74.0	54.0	7.1	13.9
Side										
2767.2	52.60	46.83	H	1.79	54.39	31.54	74.0	54.0	19.6	22.5
2767.2	52.85	47.53	V	1.79	54.64	32.24	74.0	54.0	19.4	21.8
3689.6	46.63	37.04	H	5.29	51.92	25.25	74.0	54.0	22.1	28.7
3689.6	49.81	41.78	V	5.29	55.10	29.99	74.0	54.0	18.9	24.0
4612	48.78	39.11	H	7.06	55.84	29.10	74.0	54.0	18.2	24.9
4612	48.83	39.22	V	7.06	55.89	29.21	74.0	54.0	18.1	24.8
7379.2	56.25	44.24	H	12.96	69.21	40.12	74.0	54.0	4.8	13.9
7379.2	59.52	47.72	V	12.96	72.48	43.60	74.0	54.0	1.5	10.4
8301.6	52.53	39.78	H	13.63	66.16	36.33	74.0	54.0	7.8	17.7
8301.6	54.13	41.16	V	13.63	67.76	37.71	74.0	54.0	6.2	16.3

Notes:

All the emissions above 8.31 GHz were attenuated below the limits and the noise floor of the measurement equipment.

A duty cycle correction factor of -17.08 dB was used for the calculation of the corrected average levels.

7.4.3.4 Sample Calculation:

$$R_C = R_U + CF_T$$

Where:

 CF_T = Total Correction Factor (AF+CA+AG)-DC (Average Measurements Only) R_U = Uncorrected Reading R_C = Corrected Level

AF = Antenna Factor

CA = Cable Attenuation

AG = Amplifier Gain

DC = Duty Cycle Correction Factor

Example Calculation: PeakCorrected Level: $55.61 + 1.79 = 57.4$ dB μ V/mMargin: 74 dB μ V/m – 57.4 dB μ V/m = 16.6 dB**Example Calculation: Average**Corrected Level: $50.29 + 1.79 - 17.08 = 35.0$ dB μ V/mMargin: 54 dB μ V/m – 35.0 dB μ V/m = 19.0 dB

7.5 Power Spectral Density - FCC Section 15.247(e); ISED Canada: RSS-247 5.2(2)

7.5.1 PSD Measurement Procedure (Conducted Method)

The power spectral density was measured in accordance with the FCC KDB 558074 D01 DTS Meas Guidance v03r05 Section 10.2 Method PKPSD (peak PSD). The RF output port of the EUT was directly connected to the input of the spectrum analyzer. Offset values were input for cable and external attenuation. The spectrum analyzer RBW was set to 3 kHz and VBW 10 kHz. Span was adjusted to 1.5 times the 6 dB bandwidth and the sweep time was set to auto.

7.5.2 Measurement Results

Results are shown below.

Table 7.5.2-1: Power Spectral Density

Frequency [MHz]	PSD [dBm]	Limit [dBm]	Margin [dB]
922.4	-4.66	8.0	12.66

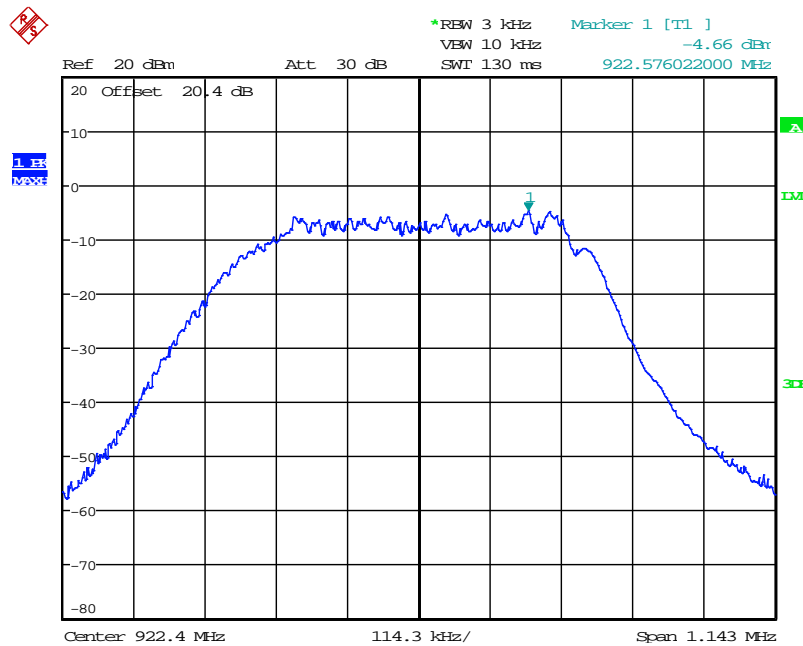

Date: 22.NOV.2016 13:31:37

Figure 7.5.2-1: Power Spectral Density

8 CONCLUSION

In the opinion of ACS, Inc., the model BX050 manufactured by Creed Monarch, Inc. meets the requirements of FCC Part 15 subpart C and Innovation, Science and Economic Development Canada's Radio Standards Specification RSS-247 for the test procedures documented in the test report.

END REPORT