

FCC Test Report

(Class II Permissive Change)

Product Name	Intel® Wireless-AC 9560
Model No	9560NGW
FCC ID	2AKHF9560NG

Applicant	TONGFANG HONGKONG (SUZHOU) LIMITED
Address	No. 10 Plant, Jianwu Phase III, Western Zone, Suzhou Industrial Park, Suzhou City, Jiangsu Province, 215000 China

Date of Receipt	Nov. 04, 2019
Issued Date	Dec. 26, 2019
Report No.	19B0034R-RFUSP11V00-C
Report Version	V1.0



The test results relate only to the samples tested.

The test results shown in the test report are traceable to the national/international standard through the calibration report of the equipment and evaluated measurement uncertainty herein.

This report must not be used to claim product endorsement by TAF or any agency of the government.

The test report shall not be reproduced without the written approval of DEKRA Testing and Certification Co., Ltd.

Test Report

Issued Date: Dec. 26, 2019

Report No.: 19B0034R-RFUSP11V00-C



Product Name	Intel® Wireless-AC 9560
Applicant	TONGFANG HONGKONG (SUZHOU) LIMITED
Address	No. 10 Plant, Jianwu Phase III, Western Zone, Suzhou Industrial Park, Suzhou City, Jiangsu Province, 215000 China
Manufacturer	INTEL CORPORATION SAS
Model No.	9560NGW
FCC ID.	2AKHF9560NG
EUT Rated Voltage	DC 3.3V
EUT Test Voltage	DC 3.3V (Power By Test Fixture)
Trade Name	Intel
Applicable Standard	FCC CFR Title 47 Part 15 Subpart E ANSI C63.4: 2014, ANSI C63.10: 2013 KDB Publication 789033
Test Result	Complied

Documented By :

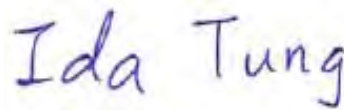

(Adm. Assistant / Ida Tung)

Tested By :



(Engineer / Yulin Chen)

Approved By :



(Director / Vincent Lin)

TABLE OF CONTENTS

Description	Page
1. GENERAL INFORMATION.....	4
1.1. EUT Description.....	4
1.2. Operational Description	7
1.3. Tested System Details.....	8
1.4. Configuration of tested System	8
1.5. EUT Exercise Software	8
1.6. Test Facility	9
1.7. List of Test Equipment	10
1.8. Uncertainty	11
2. Maximun conducted output power.....	12
2.1. Test Setup	12
2.2. Limits	13
2.3. Test Procedure	14
2.4. Uncertainty	14
2.5. Test Result of Maximum conducted output power.....	15
3. Radiated Emission.....	104
3.1. Test Setup	104
3.2. Limits	105
3.3. Test Procedure	106
3.4. Uncertainty	108
3.5. Test Result of Radiated Emission.....	109
4. Band Edge.....	443
4.1. Test Setup	443
4.2. Limits	443
4.3. Test Procedure	444
4.4. Uncertainty	446
4.5. Test Result of Band Edge	447
5. Duty Cycle.....	685
5.1. Test Setup	685
5.2. Test Procedure	685
5.3. Uncertainty	685
5.4. Test Result of Duty Cycle.....	686
6. EMI Reduction Method During Compliance Testing	695

Attachment 1: EUT Test Photographs

Attachment 2: EUT Detailed Photographs

1. GENERAL INFORMATION

1.1. EUT Description

Product Name	Intel® Wireless-AC 9560
Trade Name	Intel
FCC ID.	2AKHF9560NG
Model No.	9560NGW
Frequency Range	802.11a/n-20MHz: 5180-5320MHz, 5500-5700MHz, 5720 MHz, 5745-5825MHz 802.11n-40MHz: 5190-5310MHz, 5510-5670MHz, 5710 MHz, 5755-5795MHz 802.11ac-80MHz: 5210-5290MHz, 5530-5690MHz, 5775MHz 802.11ac-160MHz: 5250MHz, 5570MHz
Number of Channels	802.11a/n-20MHz: 25 、 802.11n-40MHz: 12 、 802.11ac-80MHz: 6 、 802.11ac-160MHz: 2
Data Rate	802.11a: 6 - 54Mbps 、 802.11n: up to 300Mbps 、 802.11ac: up to 1733.3Mbps
Type of Modulation	802.11a/n/ac: OFDM, BPSK, QPSK, 16QAM, 64QAM, 256QAM
Antenna type	PIFA Antenna
Channel Control	Auto
Antenna Gain	Refer to the table “Antenna List”
Test Platform	Product name: Notebook PC Brand: TONGFANG Model number: GM7CP6P/GM7CP0P/GM7CP7P
Power Adapter	MFR: Chicony, M/N: A17-230P1A Input: AC 100-240V~3.5A, 50-60Hz Output: DC 19.5V, 11.8A, 230W Cable Out: Shielded, 1.1m, with two ferrite cores bonded.

Antenna List

No.	Manufacturer	Part No.	Antenna type	Peak Gain
1	WGT	ANTRG7P119-0301 (Main) ANTRG7P119-0302 (Aux)	PIFA Antenna	6.64 dBi for 5.15~5.25GHz 6.37 dBi for 5.25~5.35GHz 6.87 dBi for 5.47~5.725GHz 6.29 dBi for 5.725~5.85GHz

Note: The antenna of EUT is conforming to FCC 15.203.

802.11a/n-20MHz Center Working Frequency of Each Channel:

Channel	Frequency	Channel	Frequency	Channel	Frequency	Channel	Frequency
Channel 036:	5180 MHz	Channel 040:	5200 MHz	Channel 044:	5220 MHz	Channel 048:	5240 MHz
Channel 052:	5260 MHz	Channel 056:	5280 MHz	Channel 060:	5300 MHz	Channel 064:	5320 MHz
Channel 100:	5500 MHz	Channel 104:	5520 MHz	Channel 108:	5540 MHz	Channel 112:	5560 MHz
Channel 116:	5580 MHz	Channel 120:	5600 MHz	Channel 124:	5620 MHz	Channel 128:	5640 MHz
Channel 132:	5660 MHz	Channel 136:	5680 MHz	Channel 140:	5700 MHz	Channel 144:	5720 MHz
Channel 149:	5745 MHz	Channel 153:	5765 MHz	Channel 157:	5785 MHz	Channel 161:	5805 MHz
Channel 165:	5825 MHz						

802.11n-40MHz Center Working Frequency of Each Channel:

Channel	Frequency	Channel	Frequency	Channel	Frequency	Channel	Frequency
Channel 038:	5190 MHz	Channel 046:	5230 MHz	Channel 054:	5270 MHz	Channel 062:	5310 MHz
Channel 102:	5510 MHz	Channel 110:	5550 MHz	Channel 118:	5590 MHz	Channel 126:	5630 MHz
Channel 134:	5670 MHz	Channel 142:	5710 MHz	Channel 151:	5755 MHz	Channel 159:	5795 MHz

802.11ac-80MHz Center Working Frequency of Each Channel:

Channel	Frequency	Channel	Frequency	Channel	Frequency	Channel	Frequency
Channel 042:	5210 MHz	Channel 058:	5290 MHz	Channel 106:	5530 MHz	Channel 122:	5610 MHz
Channel 138:	5690 MHz	Channel 155:	5775 MHz				

802.11ac-160MHz Center Working Frequency of Each Channel:

Channel	Frequency	Channel	Frequency
Channel 50:	5250 MHz	Channel 114:	5570 MHz

Note:

1. This device is an Intel® Wireless-AC 9560 with a built-in WLAN (802.11a/b/g/n/ac) with Bluetooth (5.0 and V3.0+HS, V2.1+EDR) transceiver, this report for 5GHz WLAN.
2. Regarding to the operation frequency, the lowest, middle and highest frequency are selected to perform the test.
3. Lowest and highest data rates are tested in each mode. Only worst case is shown in the report.
4. These tests were conducted on a sample of the equipment for the purpose of demonstrating compliance of transmitter with Part 15 Subpart E for Unlicensed National Information Infrastructure devices.
5. This is to request a Class II permissive change for FCC ID: 2AKHF9560NG, originally granted on 03/16/2018.

The major change filed under this application is:

Change #1: Additional Chassis is added, Product name: Notebook PC, Brand: TONGFANG,
 Model number: GM7CP6P/GM7CP0P/GM7CP7P

All models are listed as below:

Brand	Model No.	Difference
TONGFANG	GM7CP0P	All models are electrically identical and different model names are used to distinguish between different GPU specifications.
	GM7CP6P	
	GM7CP7P	

#2: Reduce the Output Power through firmware, and SAR measurement were evaluated.
 (Only reduce Wi-Fi Output Power, Bluetooth Output Power haven't changes).

#3: Addition an Antennas, the antenna type is same, the antenna gain is higher than the original application.

Test Mode	Mode 1 SISO A: Transmit (802.11a_6Mbps) Mode 2 SISO A: Transmit (802.11n-20BW_7.2Mbps) Mode 3 SISO A: Transmit (802.11n-40BW_15Mbps) Mode 4 SISO A: Transmit (802.11ac-80BW_32.5Mbps) Mode 5 SISO A: Transmit (802.11ac-160BW_65Mbps) Mode 6 SISO B: Transmit (802.11a_6Mbps) Mode 7 SISO B: Transmit (802.11n-20BW_7.2Mbps) Mode 8 SISO B: Transmit (802.11n-40BW_15Mbps) Mode 9 SISO B: Transmit (802.11ac-80BW_32.5Mbps) Mode 10 SISO B: Transmit (802.11ac-160BW_65Mbps) Mode 11 MIMO: Transmit (802.11n-20BW_14.4Mbps) Mode 12 MIMO: Transmit (802.11n-40BW_30Mbps) Mode 13 MIMO: Transmit (802.11ac-80BW_65Mbps) Mode 14 MIMO: Transmit (802.11ac-160BW_130Mbps) Mode 15: Transmit-SISO A Mode 16: Transmit-SISO B Mode 17: Transmit-MIMO
-----------	---

1.3. Tested System Details

The types for all equipment, plus descriptions of all cables used in the tested system (including inserted cards) are:

Product	Manufacturer	Model No.	Serial No.	Power Cord
1 Monitor	Lenovo	P27u	V302ZGXP	Non-shielded, 1.8m
2 HDD	Lenovo	F309	GXB0H43289Z152DT85	N/A
3 HDD	Transcend	TS1T5SJ25M3	D468623807	N/A
4 Microphone & Earphone	Verbatim	N/A	N/A	N/A
5 Microphone & Earphone	Verbatim	N/A	N/A	N/A
6 HDD	Transcend	TS1T5SJ25M3	D468623812	N/A
7 HDD	Transcend	TS1T5SJ25M3	D468623820	N/A
8 Notebook PC	ASUS	CP7P	N/A	N/A

Signal Cable Type	Signal cable Description
A HDMI Cable	Non-shielded, 1.8m
B Type C Cable	Shielded, 0.5m
C USB Cable	Shielded, 1.2m
D Microphone & Earphone Cable	Non-shielded, 1.2m
E Microphone & Earphone Cable	Non-shielded, 1.2m
F USB Cable	Shielded, 1.2m
G USB Cable	Shielded, 1.2m

1.4. Configuration of tested System

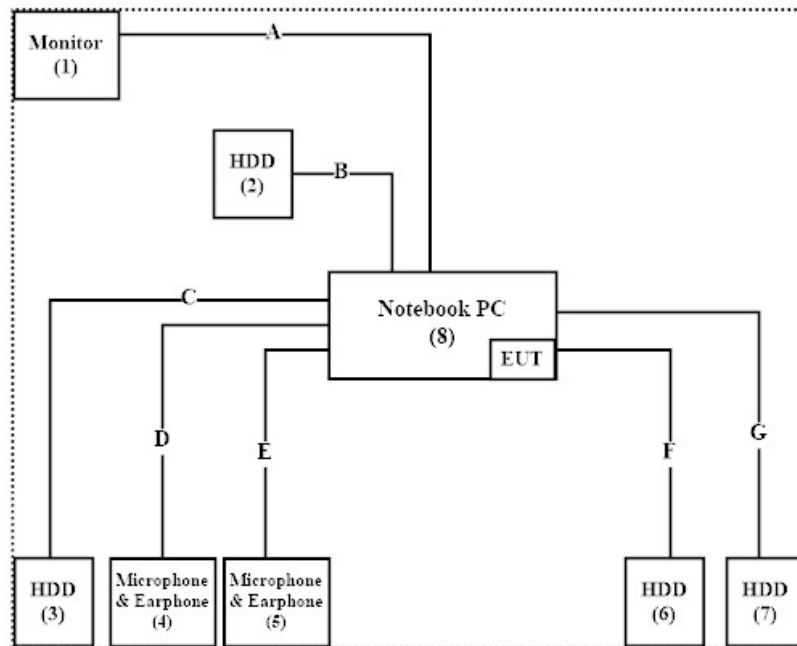

1.5. EUT Exercise Software

1. Setup the EUT as shown in Section 1.4.
2. Execute software “DRTU (Ver 11.1832.0-08048)” on the notebook PC.
3. Configure the test mode, the test channel, and the data rate.
4. Press “OK” to start the continuous Transmit.
5. Verify that the EUT works properly.

1.6. Test Facility

Ambient conditions in the laboratory:

Performed Item	Items	Required	Actual
Radiated Emission	Temperature (°C)	10~40 °C	20.6 °C
	Humidity (%RH)	10~90 %	73.9 %
Conductive	Temperature (°C)	10~40 °C	22.9 °C
	Humidity (%RH)	10~90 %	55 %

USA : FCC Registration Number: TW0023

Canada : IC Registration Number: 4075A

Site Description : Accredited by TAF
Accredited Number: 3023

Test Laboratory : DEKRA Testing and Certification Co., Ltd
Address : No.159, Sec. 2, Wenhua 1st Rd., Linkou Dist.,
New Taipei City 24457, Taiwan, R.O.C.

Phone number : 886-2-2602-7968

Fax number : 866-2-2602-3286

Email address : info.tw@dekra.com

Website : <http://www.dekra.com.tw>

1.7. List of Test Equipment

For Conducted measurements /ASR2

	Equipment	Manufacturer	Model No.	Serial No.	Cali. Data	Due. Data
X	Spectrum Analyzer	R&S	FSV30	103466	2019.12.16	2020.12.15
X	Peak Power Analyzer	KEYSIGHT	8900B	MY51000539	2019.05.06	2020.05.05
X	Power Sensor	KEYSIGHT	N1923A	MY59240002	2019.06.12	2020.06.11
X	Power Sensor	KEYSIGHT	N1923A	MY59240003	2019.06.13	2020.06.12
	Bluetooth Tester	R&S	CBT	101238	2019.01.21	2020.01.20

Note:

1. All equipments are calibrated every one year.
2. The test instruments marked with "X" are used to measure the final test results.
3. Test Software version : DEKRA Conduction Test System V9.0.5

For Radiated measurements /ACB1

	Equipment	Manufacturer	Model No.	Serial No.	Cali. Data	Due. Data
X	Loop Antenna	AMETEK	HLA6121	49611	2019.02.22	2020.02.21
X	Bi-Log Antenna	SCHWARZBECK	VULB9168	9168-953	2019.01.04	2020.01.03
X	Bi-Log Antenna	SCHWARZBECK	VULB9168	9168-953	2019.01.04	2020.01.03
X	Horn Antenna	ETS-Lindgren	3117	00203800	2019.12.12	2020.12.11
X	Horn Antenna	ETS-Lindgren	3117	00201259	2019.10.15	2020.10.14
X	Horn Antenna	ETS-Lindgren	3117	00203761	2019.10.31	2020.10.30
X	Horn Antenna	Com-Power	AH-840	101087	2019.05.30	2020.05.29
X	Pre-Amplifier	EMCI	EMC001330	980301	2019.05.20	2020.05.19
X	Pre-Amplifier	EMCI	EMC001330	980316	2019.06.14	2020.06.13
X	Pre-Amplifier	EMCI	EMC051835SE	980311	2019.06.13	2020.06.12
X	Pre-Amplifier	EMCI	EMC05820SE	980308	2019.09.02	2020.09.01
X	Pre-Amplifier	EMCI	EMC05820SE	980310	2019.06.24	2020.06.23
X	Pre-Amplifier	EMCI	EMC05835SE	980312	2019.06.03	2020.06.02
X	Pre-Amplifier	EMCI	EMC184045SE	980314	2019.05.28	2020.05.27
	Filter	MICRO TRONICS	BRM50702	G251	2019.09.03	2020.09.02
X	Filter	MICRO TRONICS	BRM50716	G188	2019.09.03	2020.09.02
X	EMI Test Receiver	R&S	ESR7	101602	2019.12.16	2020.12.15
X	Spectrum Analyzer	R&S	FSV40	101148	2019.02.08	2020.02.07
X	Coaxial Cable	SUHNER	SUCOFLEX 106	RF002	2019.07.03	2020.07.02
X	Mircoflex Cable	HUBER SUHNER	SUCOFLEX 102	MY3381/2	2019.05.28	2020.05.27

Note:

1. All equipments are calibrated every one year.
2. The test instruments marked with "X" are used to measure the final test results.
3. Test Software version : DEKRA Testing System V1.0.0.20

1.8. Uncertainty

Uncertainties have been calculated according to the DEKRA internal document, and is described in each test chapter of this report.

The reported expanded uncertainties are based on a standard uncertainty multiplied by a coverage factor of $k=2$, providing a level of confidence of approximately 95%.

Measurement uncertainties evaluated for each testing system and associated connections are given here to provide the system information for reference. Compliance determinations do not take into account measurement uncertainties for each testing system, but are based on the results of the compliance measurement.

2. Maximun conducted output power

2.1. Test Setup

26dB Occupied Bandwidth

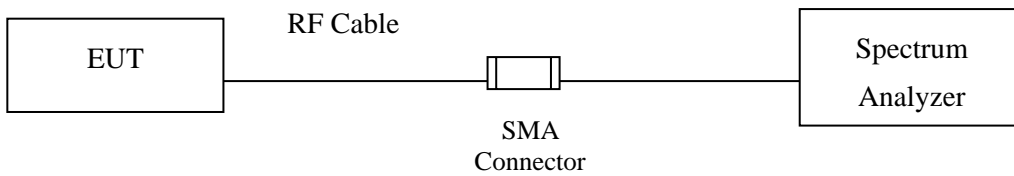

Conduction Power Measurement

Conduction Power Measurement (for 802.11an)

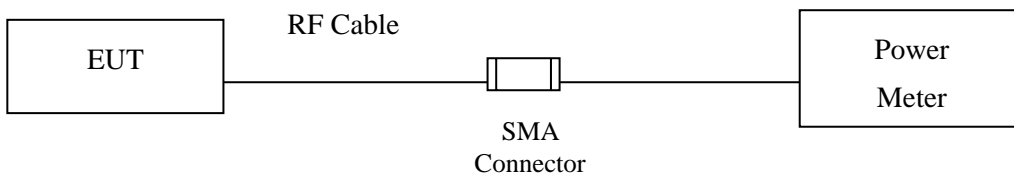

Conduction Power Measurement (for 802.11ac)

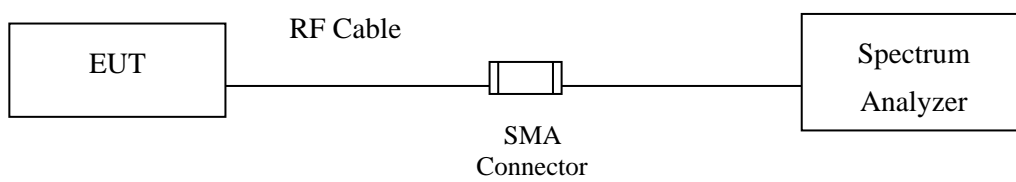

2.2. Limits

For the band 5.15-5.25 GHz,

(i) For an outdoor access point operating in the band 5.15-5.25 GHz, the maximum conducted output power over the frequency band of operation shall not exceed 1 W, provided the maximum antenna gain does not exceed 6 dBi. If transmitting antennas of directional gain greater than 6 dBi are used, the maximum conducted output power shall be reduced by the amount in dB that the directional gain of the antenna exceeds 6 dBi. The maximum e.i.r.p. at any elevation angle above 30 degrees as measured from the horizon must not exceed 125 mW (21 dBm).

(ii) For an indoor access point operating in the band 5.15-5.25 GHz, the maximum conducted output power over the frequency band of operation shall not exceed 1 W provided the maximum antenna gain does not exceed 6 dBi. In addition, if transmitting antennas of directional gain greater than 6 dBi are used, the maximum conducted output power shall be reduced by the amount in dB that the directional gain of the antenna exceeds 6 dBi.

(iii) For fixed point-to-point access points operating in the band 5.15-5.25 GHz, the maximum conducted output power over the frequency band of operation shall not exceed 1 W. Fixed point-to-point U-NII devices may employ antennas with directional gain up to 23 dBi without any corresponding reduction in the maximum conducted output power. For fixed point-to-point transmitters that employ a directional antenna gain greater than 23 dBi, a 1 dB reduction in maximum conducted output power is required for each 1 dB of antenna gain in excess of 23 dBi. Fixed, point-to-point operations exclude the use of point-to-multipoint systems, omnidirectional applications, and multiple collocated transmitters transmitting the same information. The operator of the U-NII device, or if the equipment is professionally installed, the installer, is responsible for ensuring that systems employing high gain directional antennas are used exclusively for fixed, point-to-point operations.

(iv) For mobile and portable client devices in the 5.15-5.25 GHz band, the maximum conducted output power over the frequency band of operation shall not exceed 250 mW provided the maximum antenna gain does not exceed 6 dBi. In addition, if transmitting antennas of directional gain greater than 6 dBi are used, the maximum conducted output power shall be reduced by the amount in dB that the directional gain of the antenna exceeds 6 dBi.

For the 5.25-5.35 GHz and 5.47-5.725 GHz bands, the maximum conducted output power over the frequency bands of operation shall not exceed the lesser of 250 mW or $11 \text{ dBm} + 10 \log B$, where B is the 99% emission bandwidth in megahertz. If transmitting antennas of directional gain greater than 6 dBi are used, the maximum conducted output power shall be reduced by the amount in dB that the directional gain of the antenna exceeds 6 dBi.

For the band 5.725-5.85 GHz, the maximum conducted output power over the frequency band of operation shall not exceed 1 W. In addition, if transmitting antennas of directional gain greater than 6 dBi are used, the maximum conducted output power shall be reduced by the amount in dB that the directional gain of the antenna exceeds 6 dBi. However, fixed point-to-point UNII devices operating in this band may employ transmitting antennas with directional gain greater than 6 dBi without any corresponding reduction in transmitter conducted power. Fixed, point-to-point operations exclude the use of point-to-multipoint systems, omnidirectional applications, and multiple collocated transmitters transmitting the same information. The operator of the U-NII device, or if the equipment is professionally installed, the installer, is responsible for ensuring that systems employing high gain directional antennas are used exclusively for fixed, point-to-point operations.

2.3. Test Procedure

As an alternative to FCC KDB-789033, the EUT maximum conducted output power was measured with an average power meter employing a video bandwidth greater than the 6dB BW of the emission under test. Maximum conducted output power was read directly from the meter across all data rates, and across three channels within each sub-band. Special care was used to make sure that the EUT was transmitting in continuous mode. This method exceeds the limitations of FCC KDB-789033, and provides more accurate measurements.

802.11an (BW \leq 40MHz) Maximum conducted output power using KDB 789033 section E)3)b) Method PM-G (Measurement using a gated RF average power meter)

Note: the power meter have a video bandwidth that is greater than or equal to the measurement bandwidth.

802.11ac (BW=80MHz) Maximum conducted output power using KDB 789033 section E)2)b) Method SA-1 (trace averaging with the EUT transmitting at full power throughout each sweep).

When transmitted signals consist of two or more non-contiguous spectrum segments (e.g., 80+80 MHz mode) or when a single spectrum segment of a transmission crosses the boundary between two adjacent U-NII bands, KDB 644545 D03 section D) procedure is used for measurements.

2.4. Uncertainty

Power Meter: ± 0.95 dB

Spectrum Analyzer: ± 1.30 dB

2.5. Test Result of Maximum conducted output power

Product : Intel® Wireless-AC 9560
 Test Item : Maximum conducted output power
 Test Date : 2019/12/03
 Test Mode : Mode 1 SISO A: Transmit (802.11a_6Mbps)

Cable loss=1.0dB		Maximum conducted output power							
Channel No.	Frequency (MHz)	Data Rate (Mbps)							
		6	9	12	18	24	36	48	54
		Measurement Level (dBm)							
36	5180	18.58	--	--	--	--	--	--	--
44	5220	21.21	21.16	21.10	21.07	21.01	20.96	20.92	20.85
48	5240	20.57	--	--	--	--	--	--	--
52	5260	20.87	--	--	--	--	--	--	--
60	5300	21.21	21.15	21.08	21.02	20.97	20.92	20.88	20.83
64	5320	16.02	--	--	--	--	--	--	--
100	5500	19.06	--	--	--	--	--	--	--
116	5580	20.81	20.77	20.72	20.67	20.63	20.56	20.53	20.46
140	5700	16.77	--	--	--	--	--	--	--
149	5745	20.87	--	--	--	--	--	--	--
157	5785	20.86	20.80	20.74	20.69	20.64	20.60	20.57	20.50
165	5825	20.80	--	--	--	--	--	--	--

Note: Maximum conducted output power Value =Reading value on average power meter + cable loss

Maximum conducted output power Measurement:

Channel No	Frequency Range (MHz)	26dB Bandwidth (MHz)	Output Power (dBm)	Output Power Limit		Result
				(dBm)	dBm+10log(BW)	
36	5180	--	18.58	23.36	--	Pass
44	5220	--	21.21	23.36	--	Pass
48	5240	--	20.57	23.36	--	Pass
52	5260	28.650	20.87	23.63	25.20	Pass
60	5300	31.250	21.21	23.63	25.58	Pass
64	5320	23.750	16.02	23.63	24.39	Pass
100	5500	23.400	19.06	23.13	24.69	Pass
116	5580	28.150	20.81	23.13	24.62	Pass
140	5700	24.200	16.77	23.13	23.97	Pass
149	5745	--	20.87	29.71	--	Pass
157	5785	--	20.86	29.71	--	Pass
165	5825	--	20.80	29.71	--	Pass

26dB Occupied Bandwidth:

Channel 52

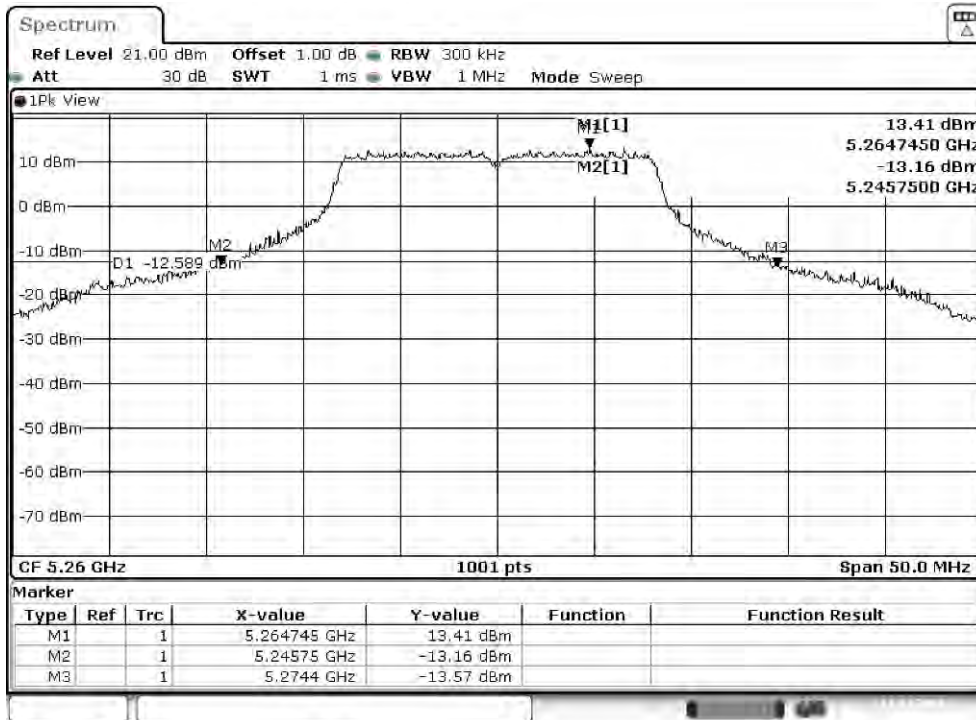

Channel 60

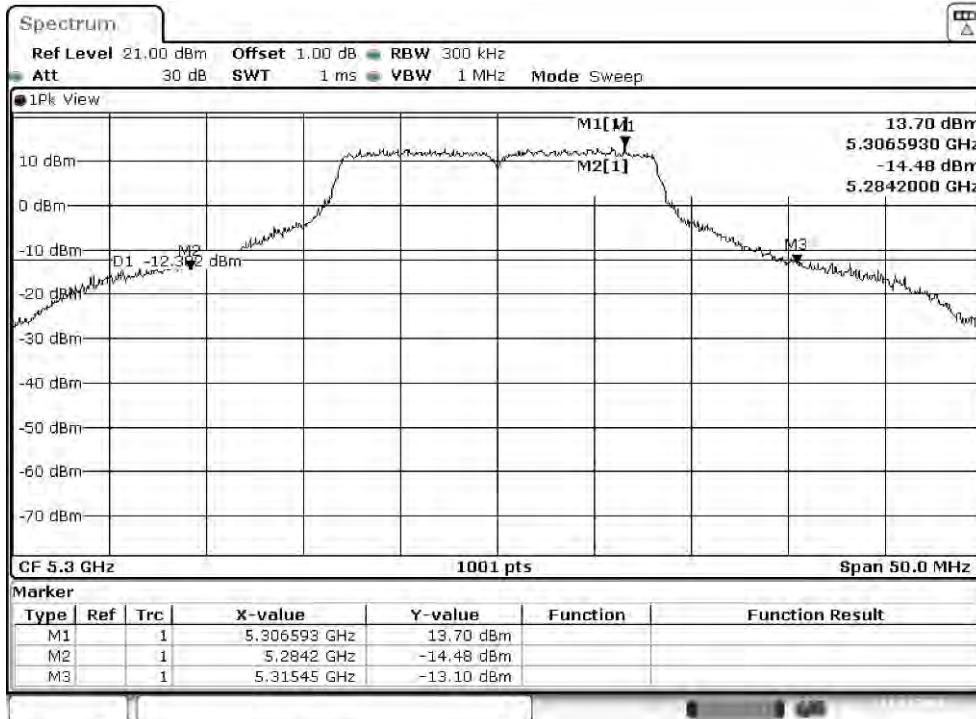

Channel 64

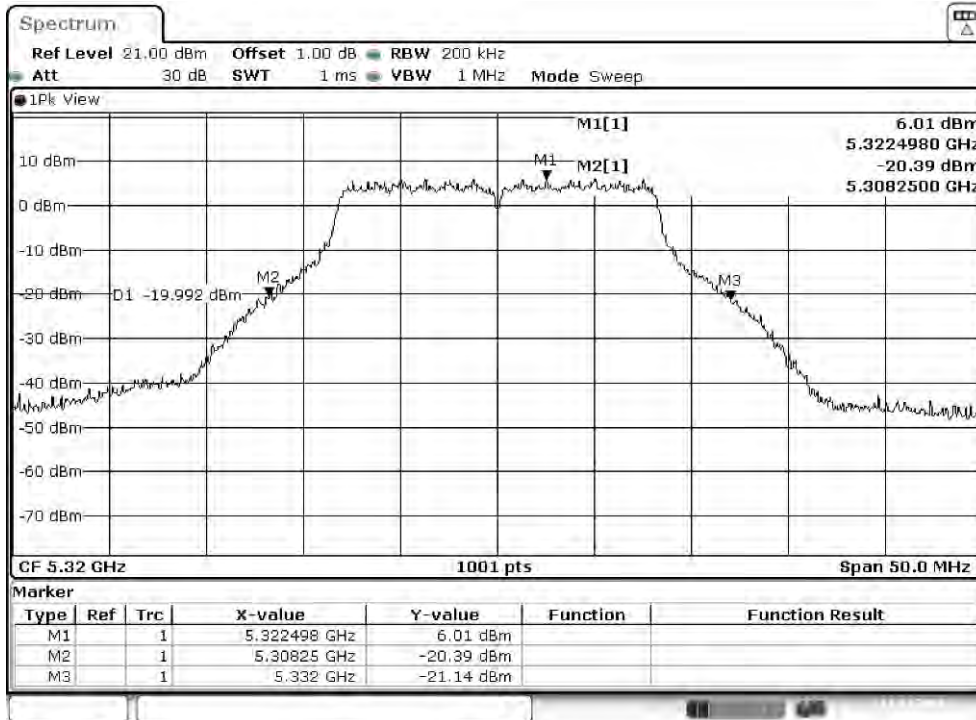

Channel 100

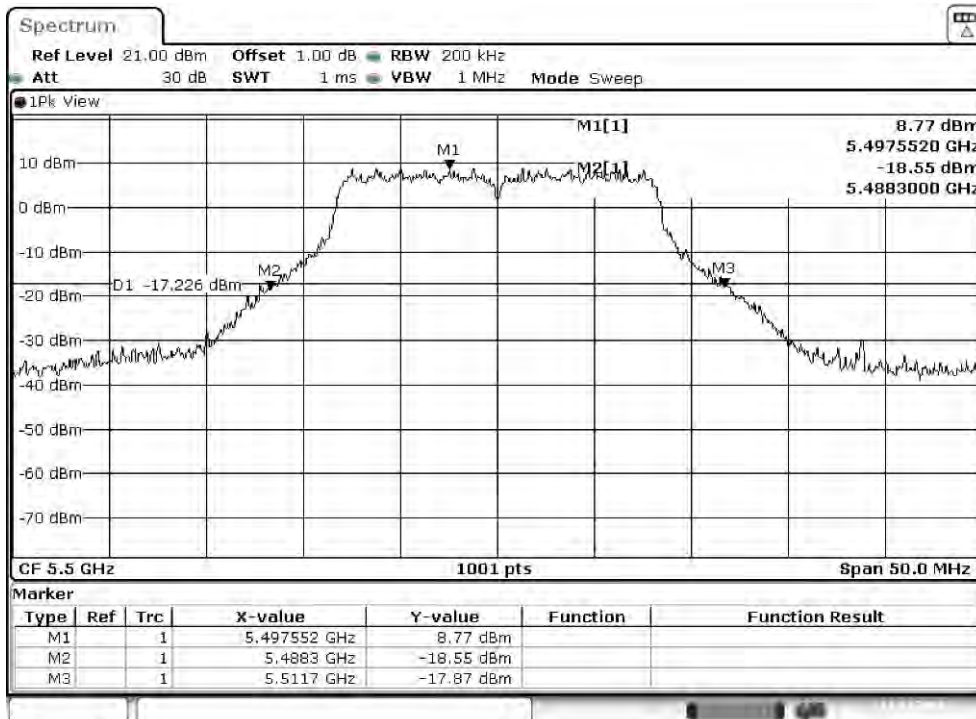

Channel 116

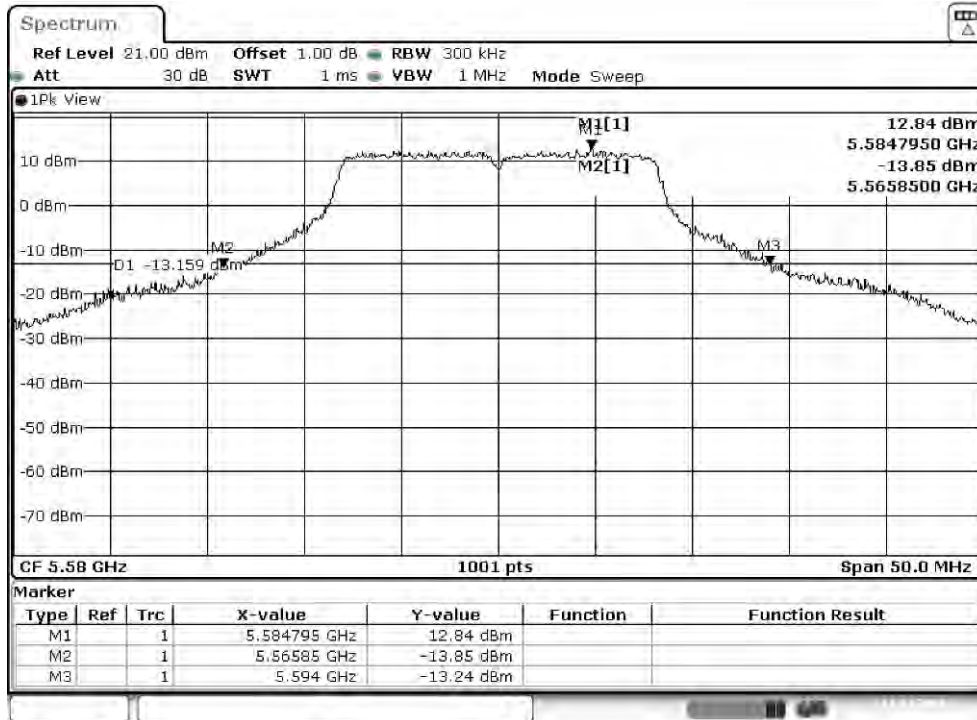

Channel 140

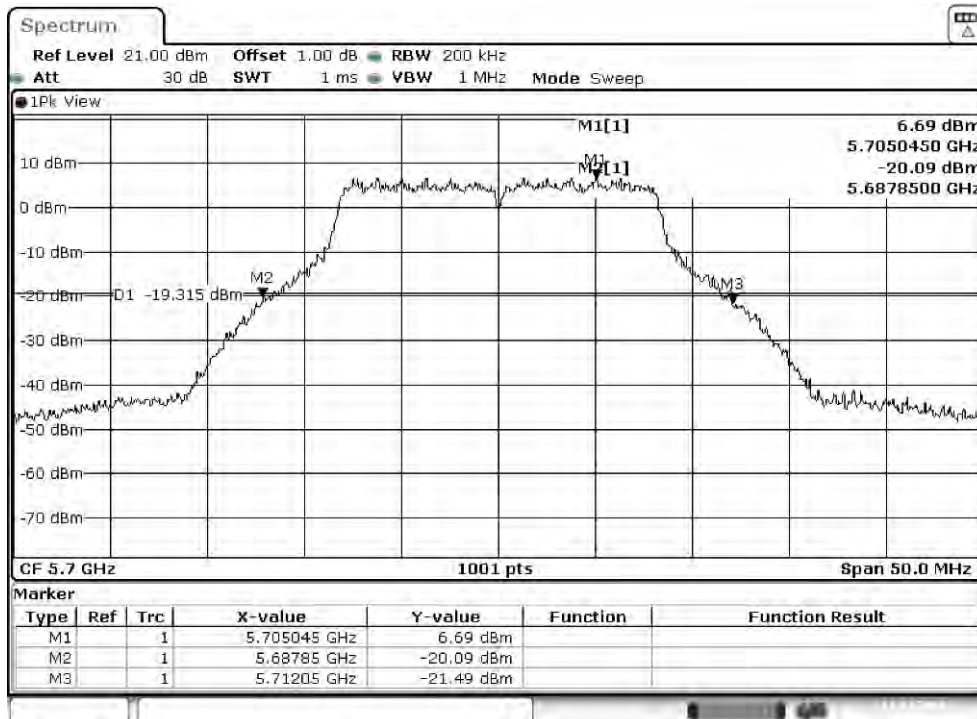

Product : Intel® Wireless-AC 9560
 Test Item : Maximum conducted output power
 Test Date : 2019/12/03
 Test Mode : Mode 2 SISO A: Transmit (802.11n-20BW_7.2Mbps)

Cable loss=1.0dB		Maximum conducted output power							
Channel No.	Frequency (MHz)	Data Rate (Mbps)							
		7.2	14.4	21.7	28.9	43.3	57.8	65	72.2
		Measurement Level (dBm)							
36	5180	17.73	--	--	--	--	--	--	--
44	5220	21.55	21.48	21.43	21.39	21.34	21.29	21.26	21.22
48	5240	20.68	--	--	--	--	--	--	--
52	5260	20.69	--	--	--	--	--	--	--
60	5300	21.36	21.31	21.27	21.23	21.20	21.15	21.09	21.04
64	5320	16.16	--	--	--	--	--	--	--
100	5500	14.09	--	--	--	--	--	--	--
116	5580	20.96	20.90	20.86	20.82	20.78	20.74	20.68	20.63
140	5700	16.20	--	--	--	--	--	--	--
144(U-NII-2C)	5720	19.90	19.86	19.80	19.76	19.72	19.68	19.64	19.57
144(U-NII-3)	5720	14.46	14.40	14.33	14.29	14.23	14.16	14.12	14.09
149	5745	20.63	--	--	--	--	--	--	--
157	5785	21.82	21.78	21.72	21.69	21.65	21.61	21.56	21.51
165	5825	20.61	--	--	--	--	--	--	--

Note: Maximum conducted output power Value =Reading value on average power meter + cable loss

Maximum conducted output power Measurement:

Channel No	Frequency Range (MHz)	26dB Bandwidth (MHz)	Output Power (dBm)	Output Power Limit		Result
				(dBm)	dBm+10log(BW)	
36	5180	--	17.73	23.36	--	Pass
44	5220	--	21.55	23.36	--	Pass
48	5240	--	20.68	23.36	--	Pass
52	5260	33.900	20.69	23.63	25.93	Pass
60	5300	44.900	21.36	23.63	27.15	Pass
64	5320	25.150	16.16	23.63	24.64	Pass
100	5500	24.900	14.09	23.13	24.09	Pass
116	5580	29.050	20.96	23.13	24.76	Pass
140	5700	24.450	16.20	23.13	24.01	Pass
144(U-NII-2C)	5720	23.681	19.90	23.13	23.87	Pass
144(U-NII-3)	5720	--	14.46	29.71	--	Pass
149	5745	--	20.63	29.71	--	Pass
157	5785	--	21.82	29.71	--	Pass
165	5825	--	20.61	29.71	--	Pass

26dB Occupied Bandwidth:

Channel 52

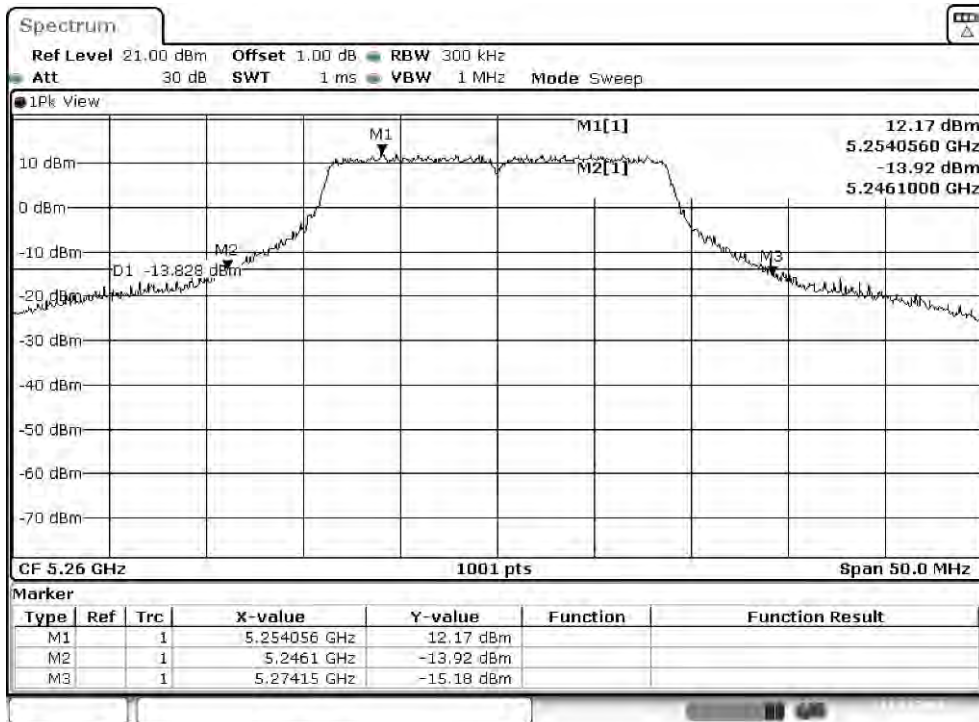

Channel 60

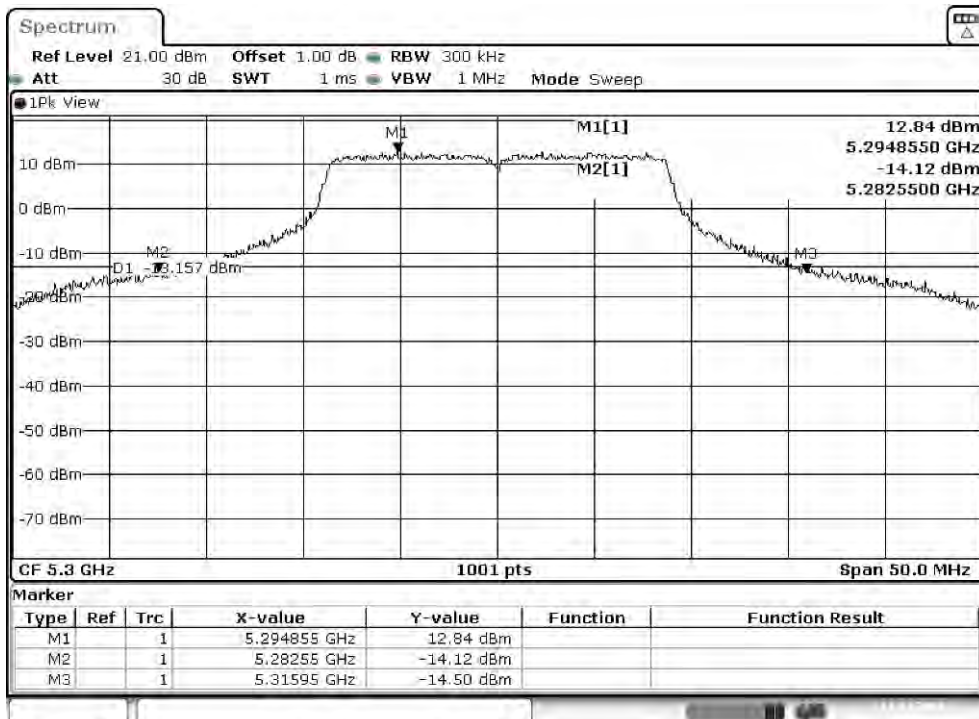

Channel 64

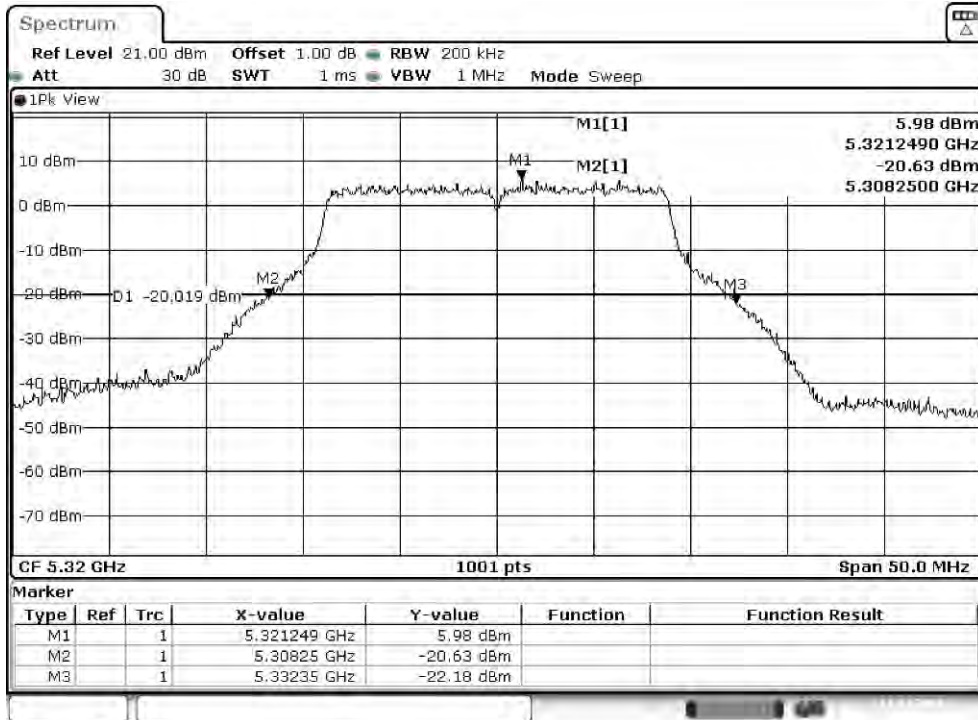

Channel 100

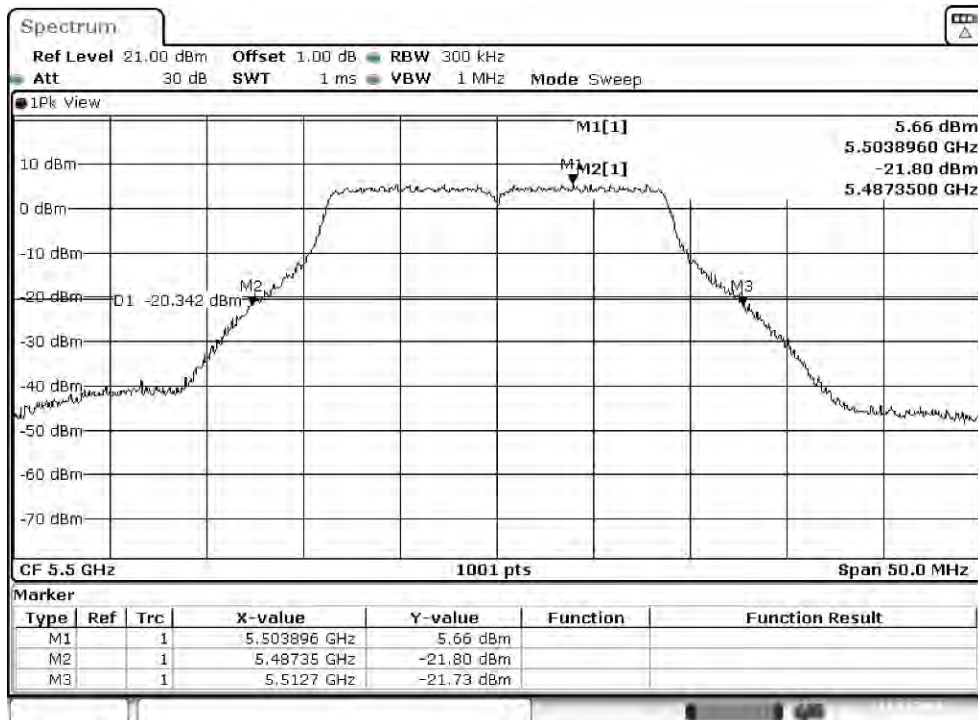

Channel 116

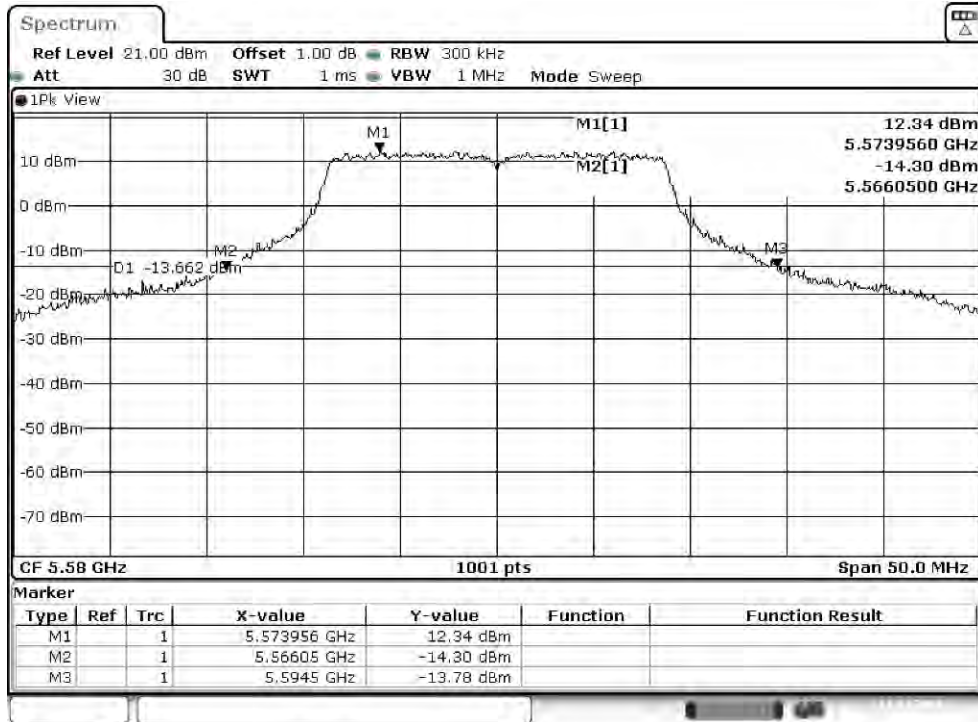

Channel 140

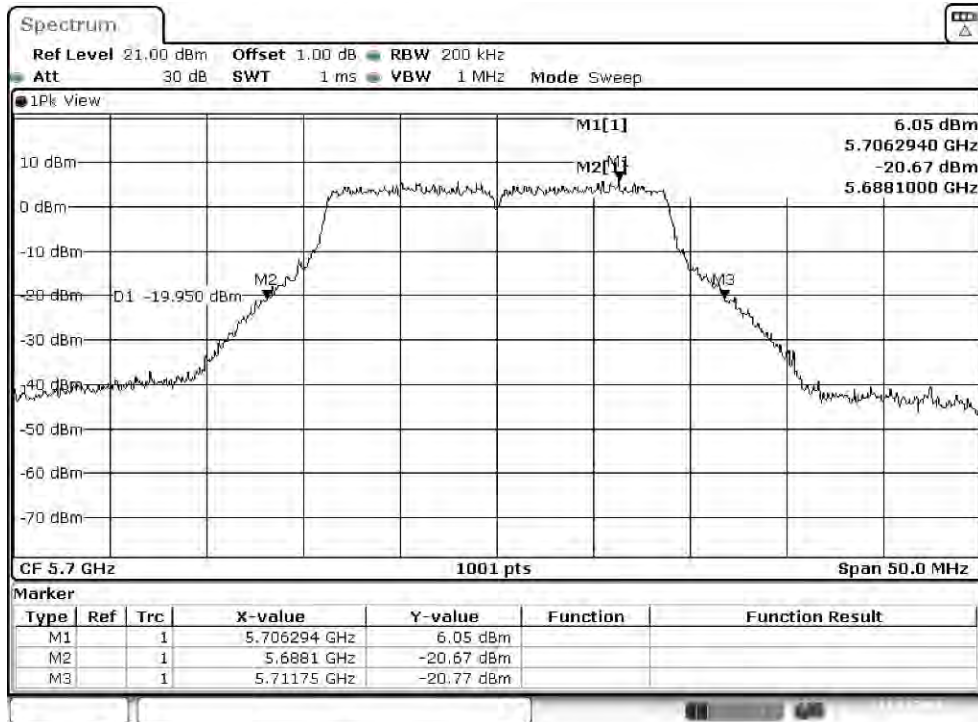

Channel 144

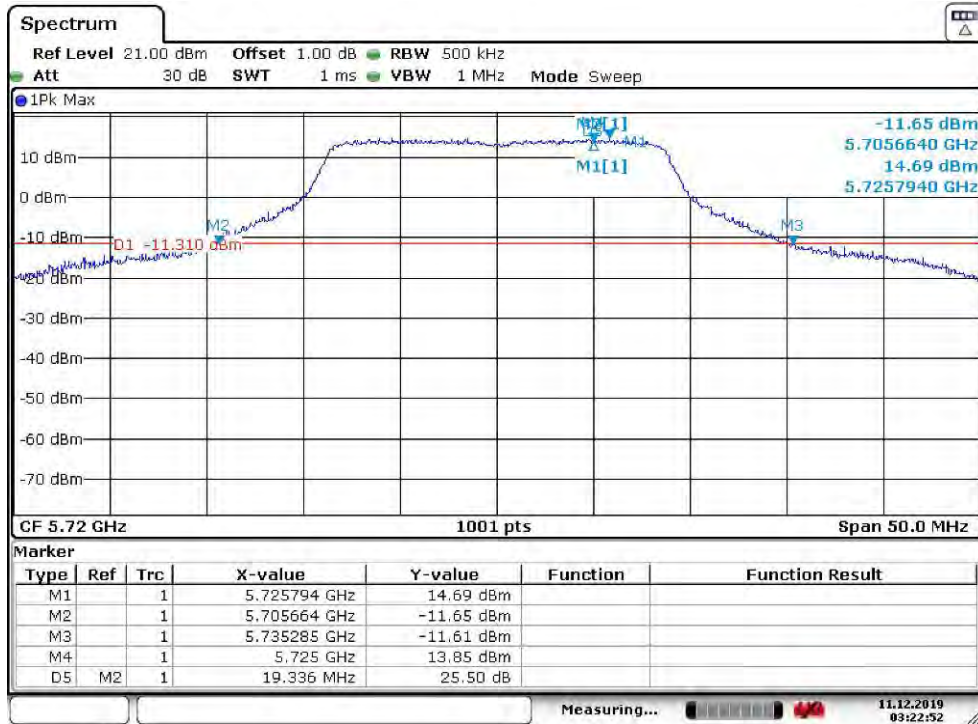

Maximum conducted output power:

Channel 144 (U-NII-2C)

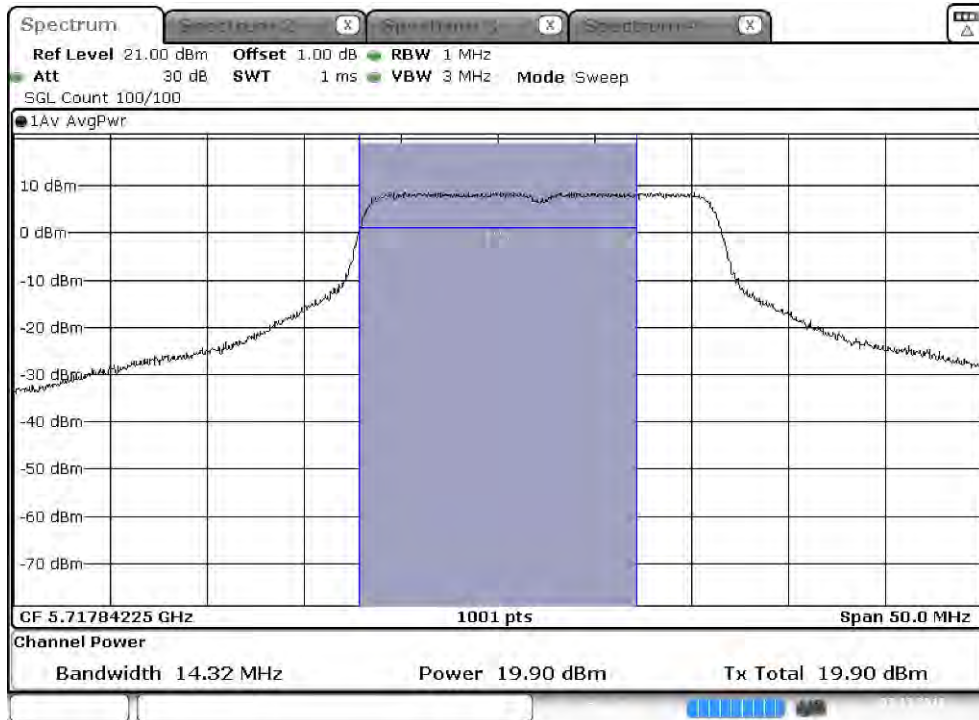

Maximum conducted output power:

Channel 144 (U-NII-3)

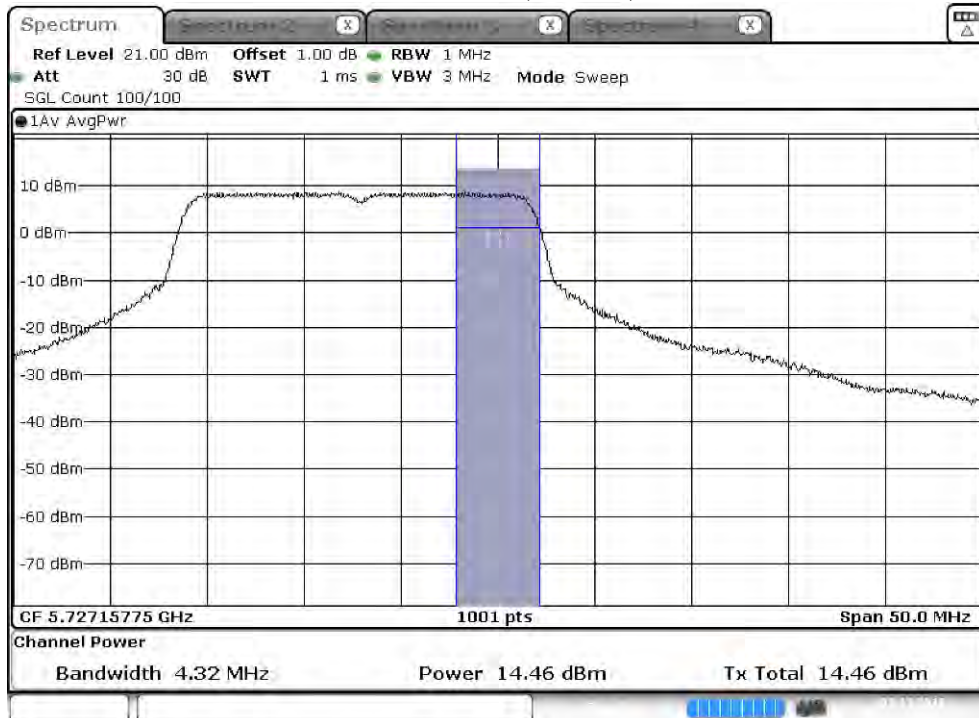

Product : Intel® Wireless-AC 9560
 Test Item : Maximum conducted output power
 Test Date : 2019/12/03
 Test Mode : Mode 3 SISO A: Transmit (802.11n-40BW_15Mbps)

Cable loss=1.0dB		Maximum conducted output power							
Channel No.	Frequency (MHz)	Data Rate (Mbps)							
		15	30	45	60	90	120	135	150
		Measurement Level (dBm)							
38	5190	18.10	--	--	--	--	--	--	--
46	5230	19.40	19.35	19.31	19.26	19.20	19.17	19.11	19.07
54	5270	18.72	--	--	--	--	--	--	--
62	5310	14.46	14.41	14.34	14.29	14.23	14.17	14.14	14.11
102	5510	14.19	--	--	--	--	--	--	--
110	5550	21.37	21.34	21.28	21.24	21.19	21.12	21.08	21.05
134	5670	18.54	--	--	--	--	--	--	--
142(U-NII-2C)	5710	19.62	19.57	19.52	19.49	19.42	19.38	19.31	19.25
142(U-NII-3)	5710	9.49	9.42	9.35	9.30	9.24	9.21	9.16	9.12
151	5755	19.09	--	--	--	--	--	--	--
159	5795	19.55	19.52	19.45	19.40	19.36	19.30	19.27	19.23

Note: Maximum conducted output power Value =Reading value on average power meter + cable loss

Maximum conducted output power Measurement:

Channel No	Frequency Range (MHz)	26dB Bandwidth (MHz)	Output Power (dBm)	Output Power Limit		Result
				(dBm)	dBm+10log(BW)	
38	5190	--	18.10	23.36	--	Pass
46	5230	--	19.40	23.36	--	Pass
54	5270	51.700	18.72	23.63	27.76	Pass
62	5310	44.500	14.46	23.63	27.11	Pass
102	5510	44.600	14.19	23.13	26.62	Pass
110	5550	73.500	21.37	23.13	28.79	Pass
134	5670	45.300	18.54	23.13	26.69	Pass
142(U-NII-2C)	5710	53.500	19.62	23.13	27.41	Pass
142(U-NII-3)	5710	--	9.49	29.71	--	Pass
151	5755	--	19.09	29.71	--	Pass
159	5795	--	19.55	29.71	--	Pass

26dB Occupied Bandwidth:

Channel 54

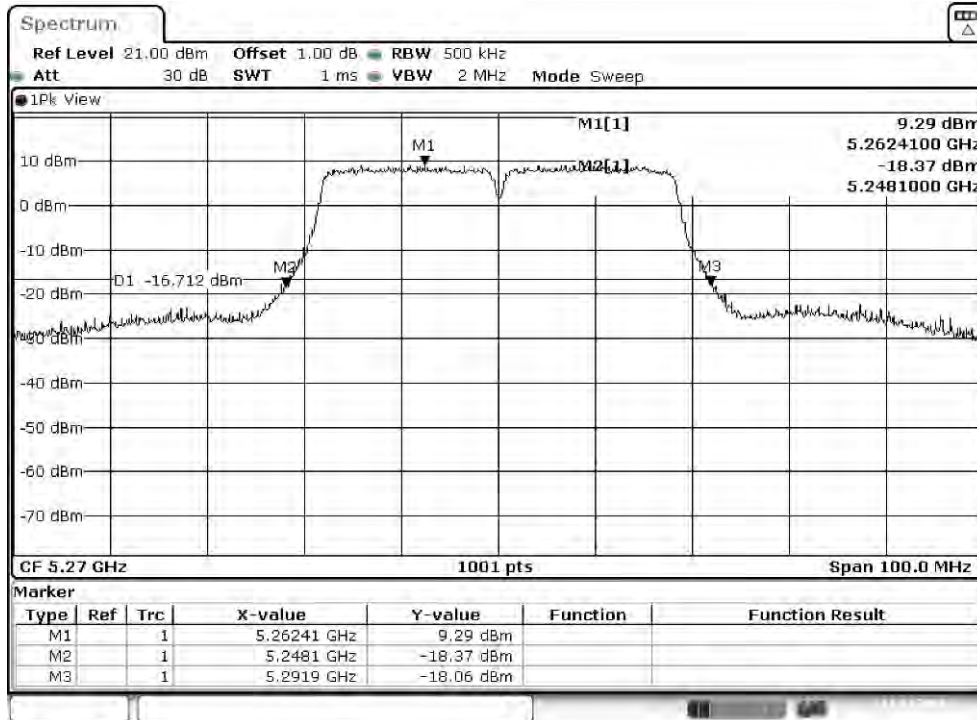

Channel 62

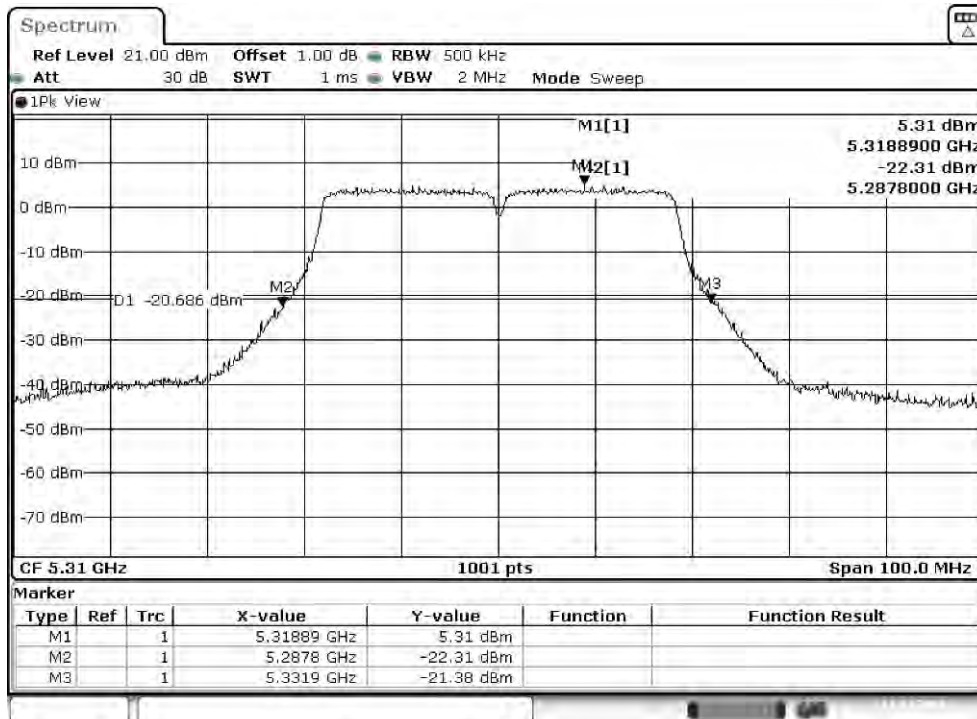

Channel 102

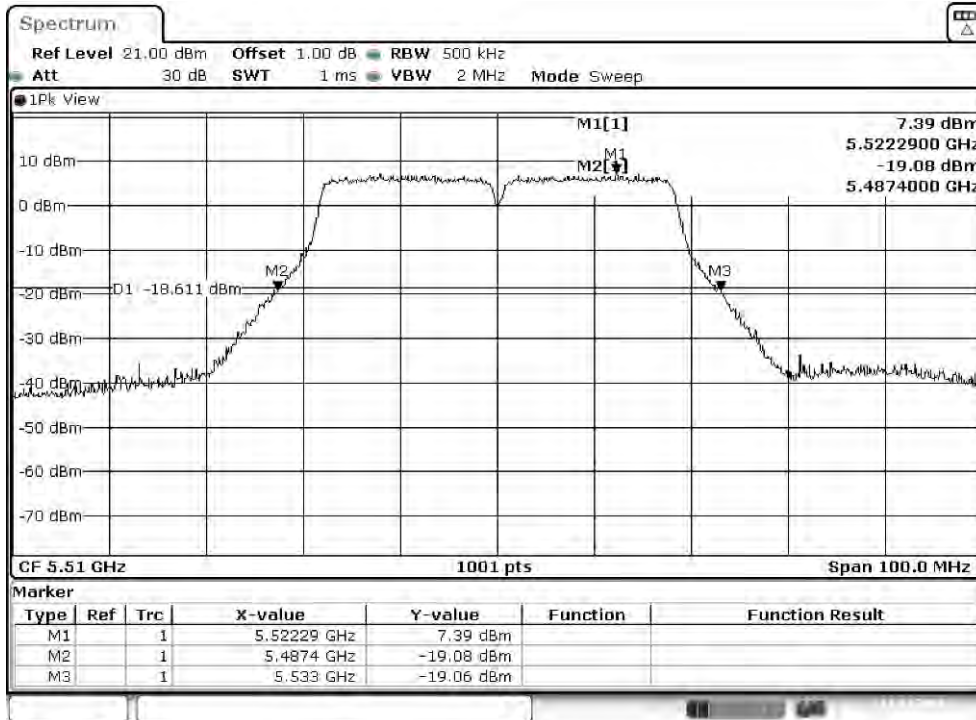

Channel 110

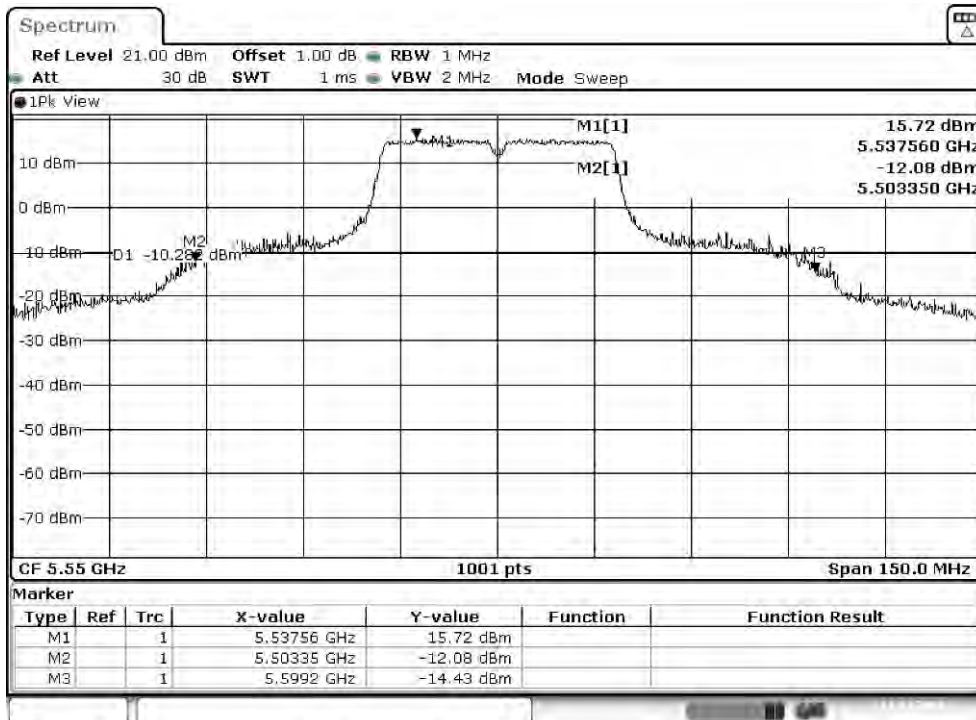

Channel 134

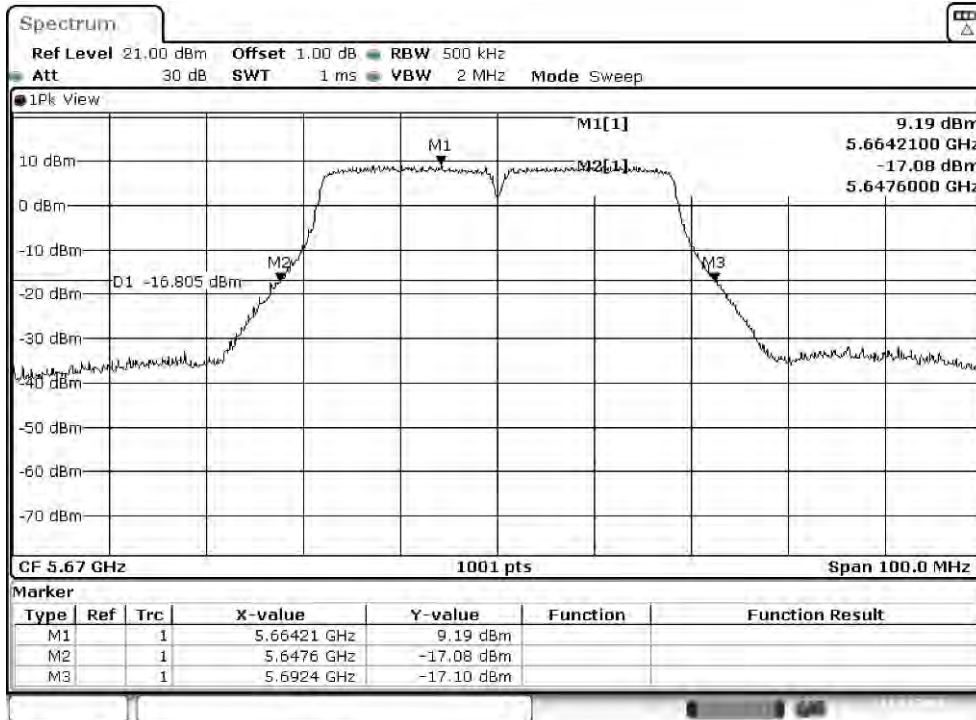

Channel 142

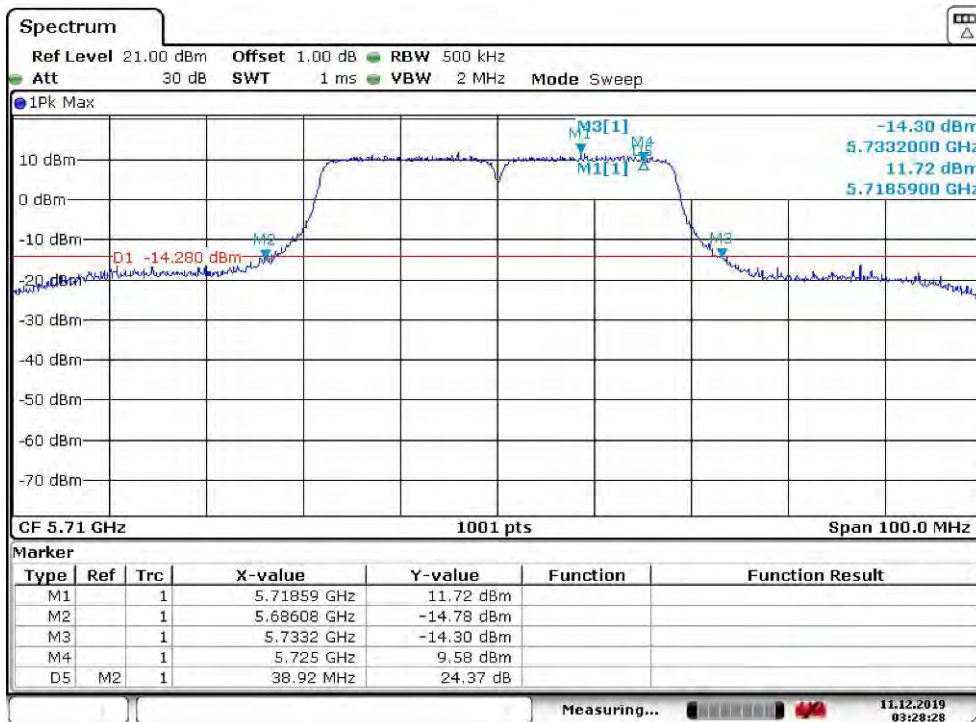

Maximum conducted output power:

Channel 142 (U-NII-2C)

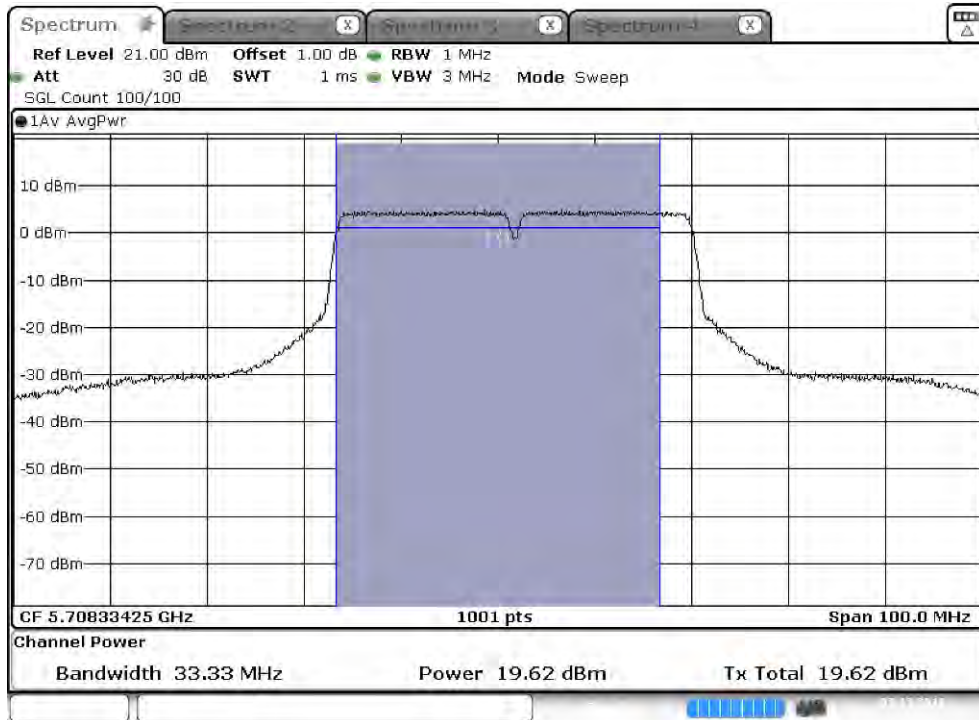

Maximum conducted output power:

Channel 142 (U-NII-3)

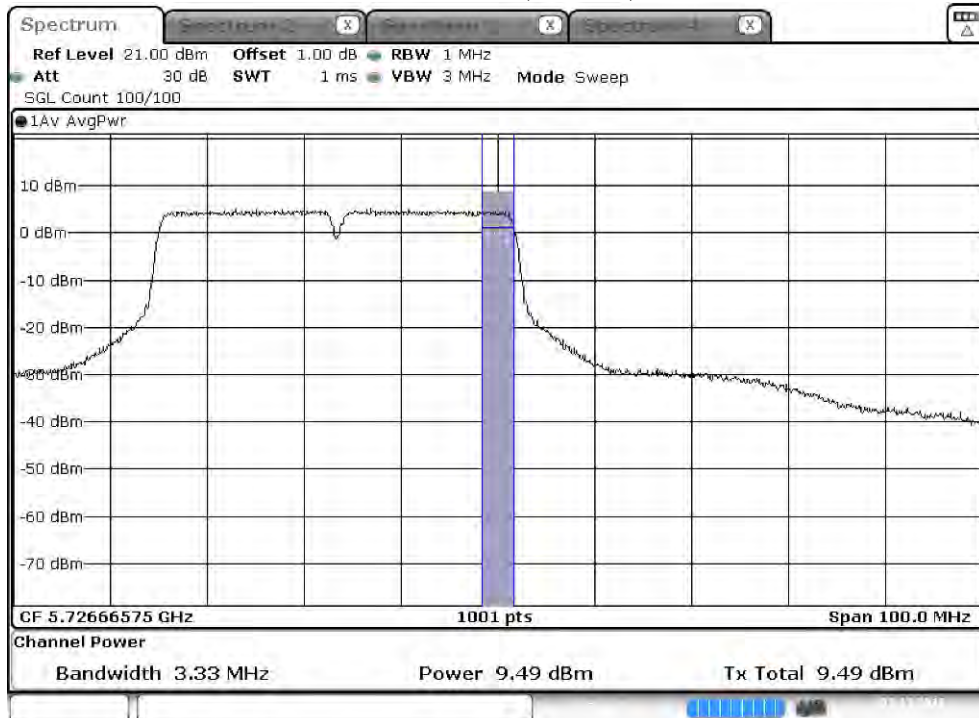

Product : Intel® Wireless-AC 9560
 Test Item : Maximum conducted output power
 Test Date : 2019/12/03
 Test Mode : Mode 4 SISO A: Transmit (802.11ac-80BW_32.5Mbps)

Cable loss=1.0dB		Maximum conducted output power									
Channel No	Frequency (MHz)	Data Rate (Mbps)									
		32.5	65	97.5	130	195	260	292.5	325	390	433.3
42	5210	17.24	17.21	17.17	17.12	17.05	17.01	16.95	16.89	16.84	16.80
58	5290	15.52	15.45	15.41	15.38	15.32	15.27	15.20	15.16	15.09	15.05
106	5530	17.01	--	--	--	--	--	--	--	--	--
122	5610	20.55	20.51	20.45	20.40	20.33	20.27	20.22	20.18	20.13	20.08
138 (U-NII-2C)	5690	20.43	--	--	--	--	--	--	--	--	--
138 (U-NII-3)	5690	4.29	--	--	--	--	--	--	--	--	--
155	5775	17.98	17.93	17.90	17.84	17.79	17.73	17.68	17.65	17.59	17.54

Note: Maximum conducted output power Value =Reading value on Spectrum Analyzer + cable loss

Maximum conducted output power Measurement:

Channel No	Frequency Range (MHz)	26dB Bandwidth (MHz)	Output Power (dBm)	Output Power Limit		Result
				(dBm)	dBm+10log(BW)	
42	5210	--	17.24	23.36	--	Pass
58	5290	85.600	15.52	23.63	29.95	Pass
106	5530	87.200	17.01	23.13	29.54	Pass
122	5610	86.200	20.55	23.13	29.49	Pass
138 (U-NII-2C)	5690	106.350	20.43	23.13	30.40	Pass
138 (U-NII-3)	5690	--	4.29	29.71	--	Pass
155	5775	--	17.98	29.71	--	Pass

26dB Occupied Bandwidth:

Channel 42

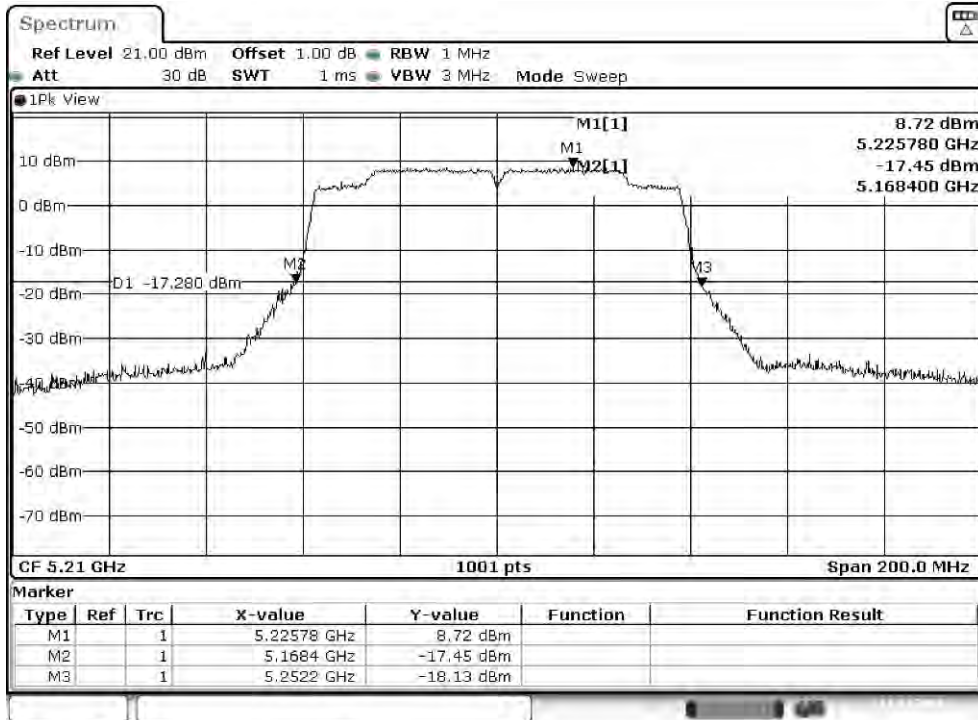

Channel 58

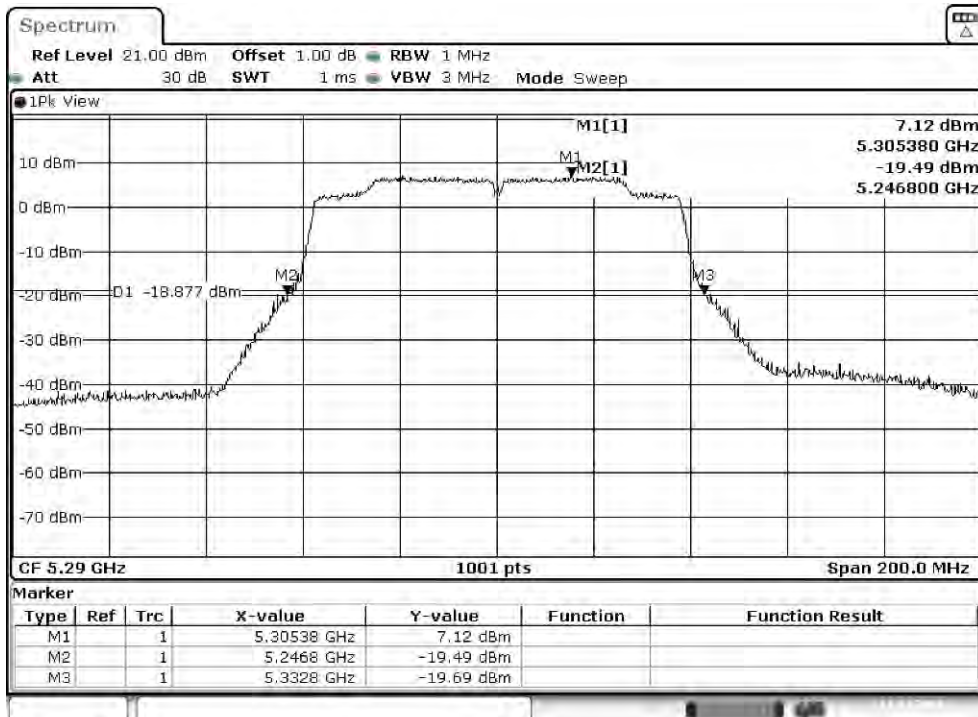

Channel 106

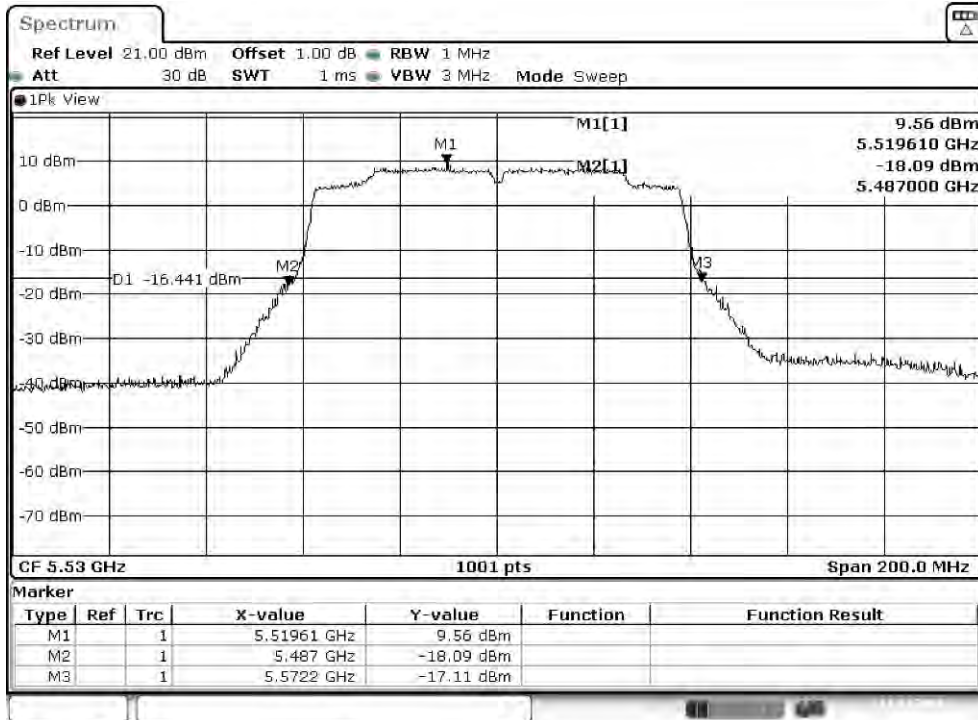

Channel 122

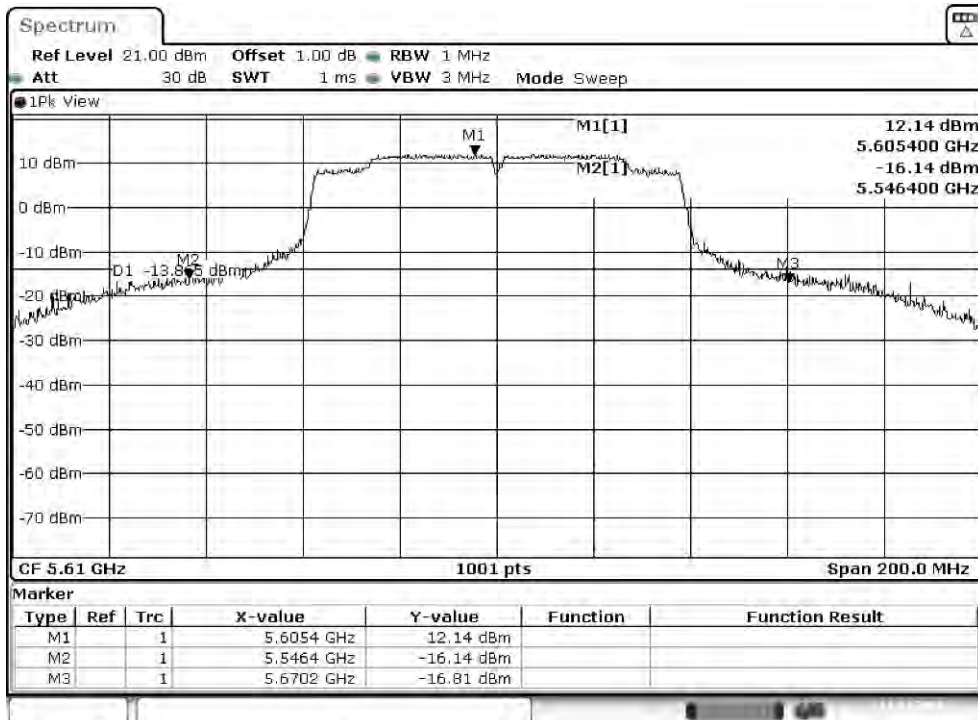

Channel 138

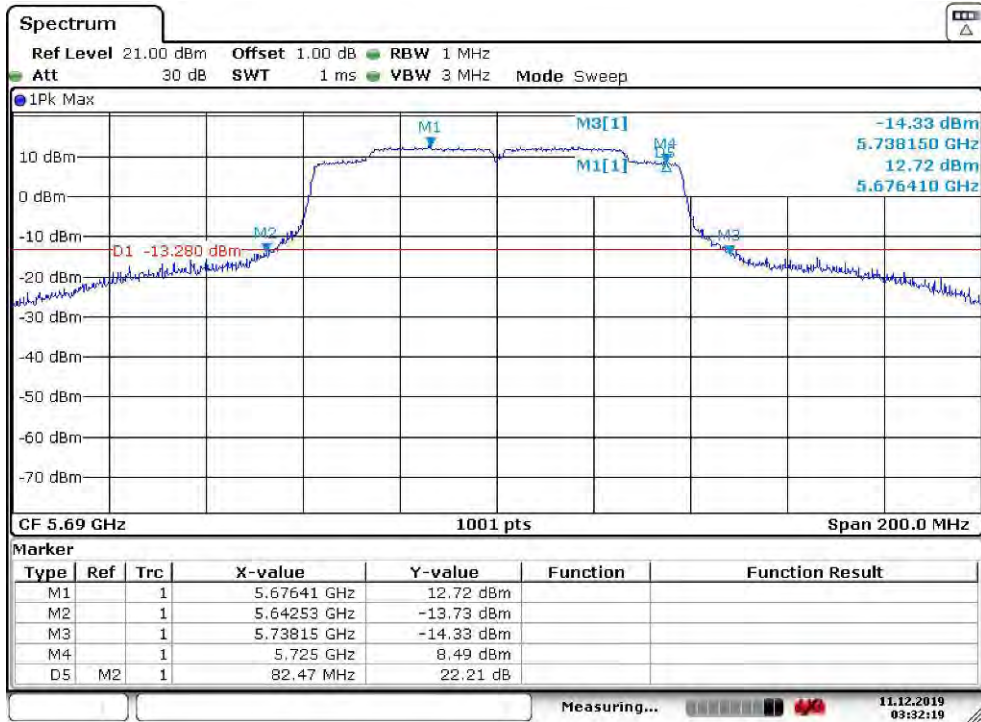

Maximum conducted output power:

Channel 42

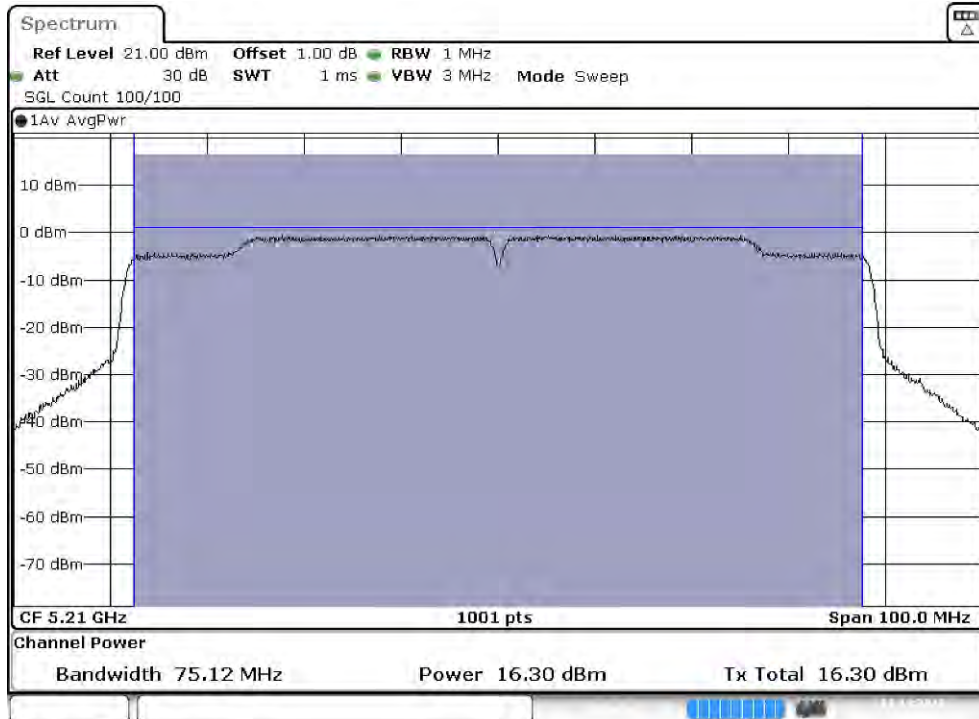

Maximum conducted output power:

Channel 58

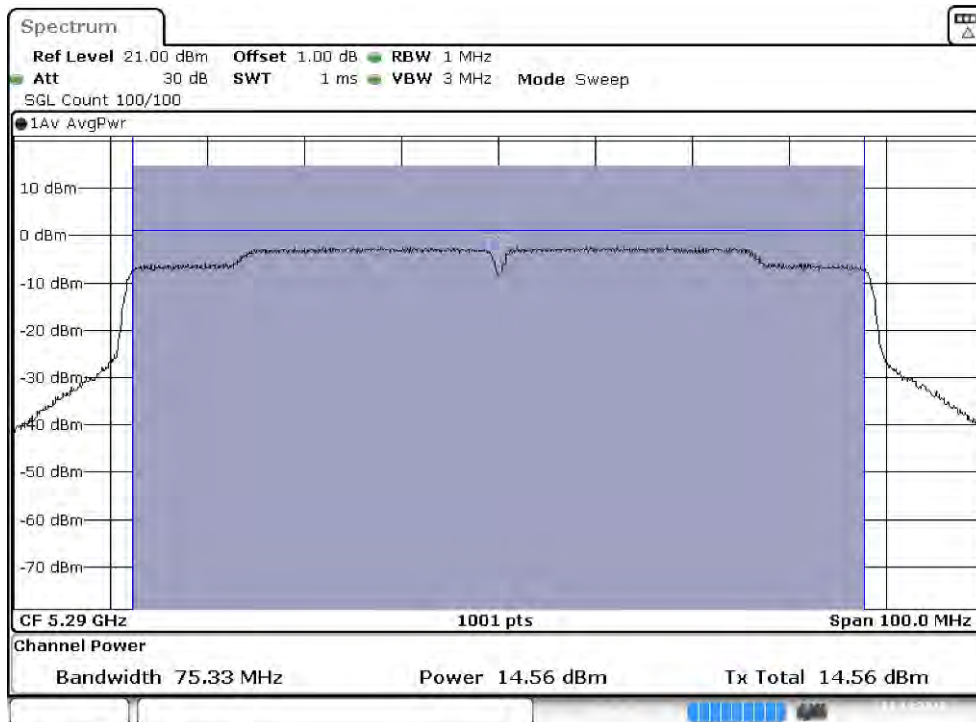

Maximum conducted output power:

Channel 106

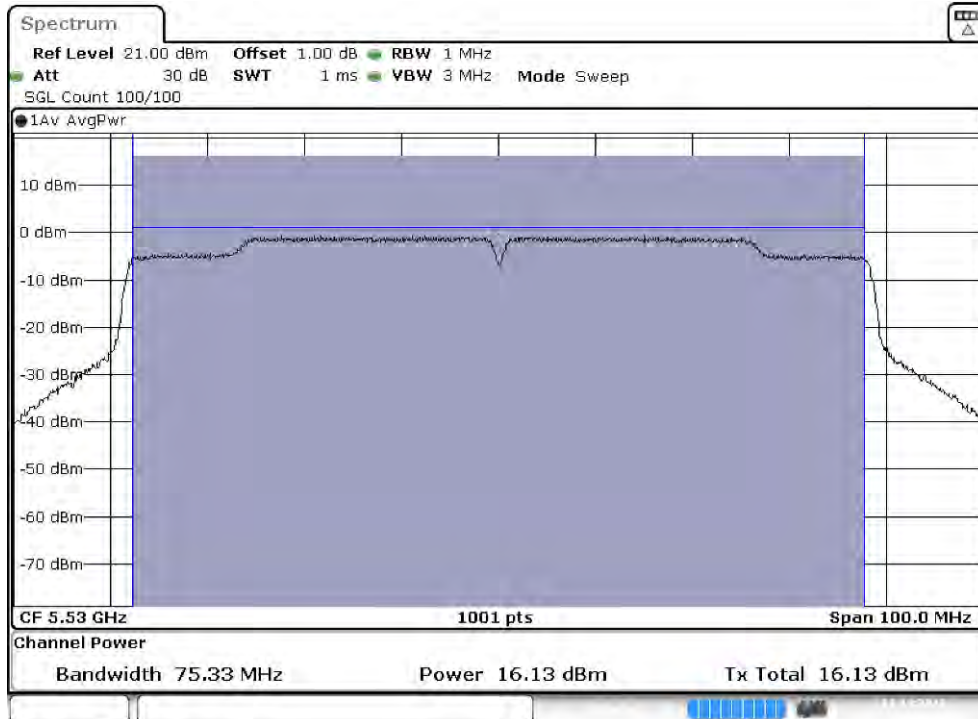

Maximum conducted output power:

Channel 122

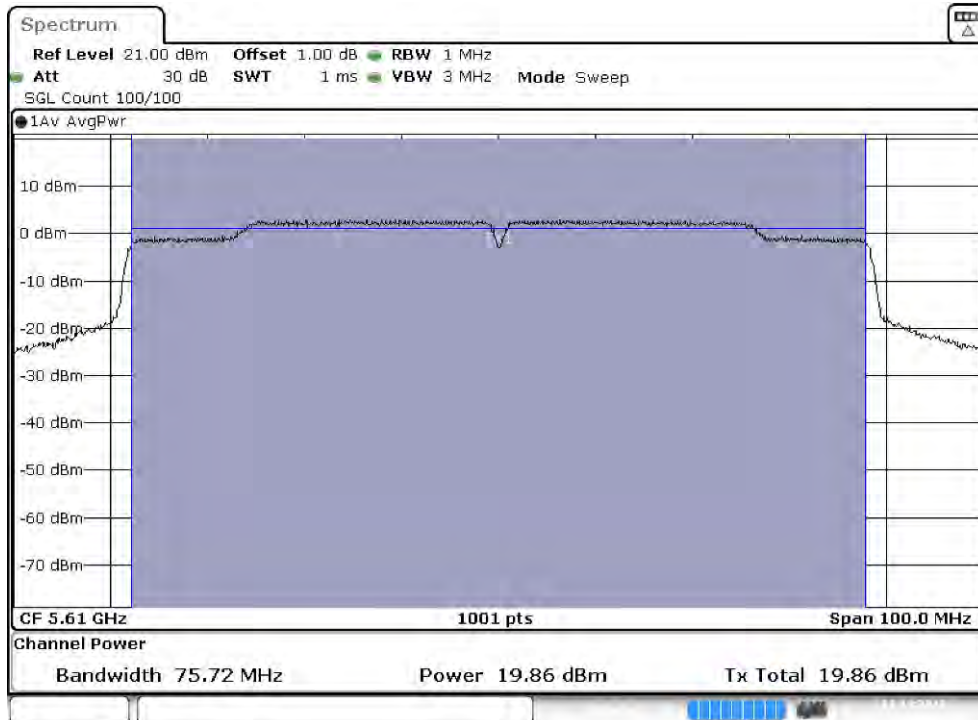

**Maximum conducted output power:
Channel 138 (U-NII-2C)**

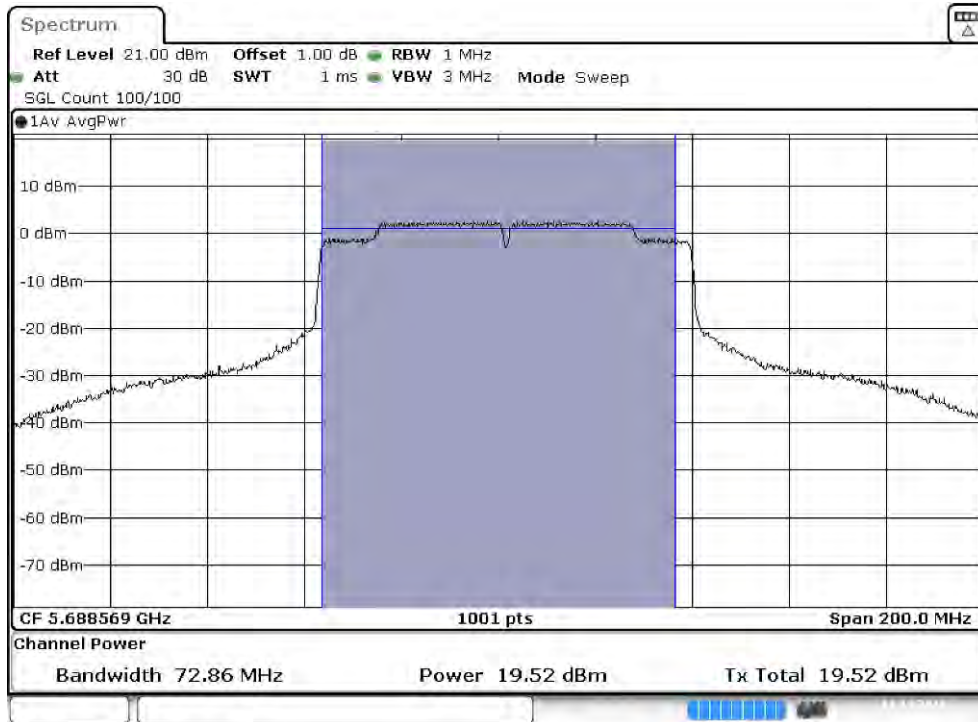

**Maximum conducted output power:
Channel 138 (U-NII-3)**

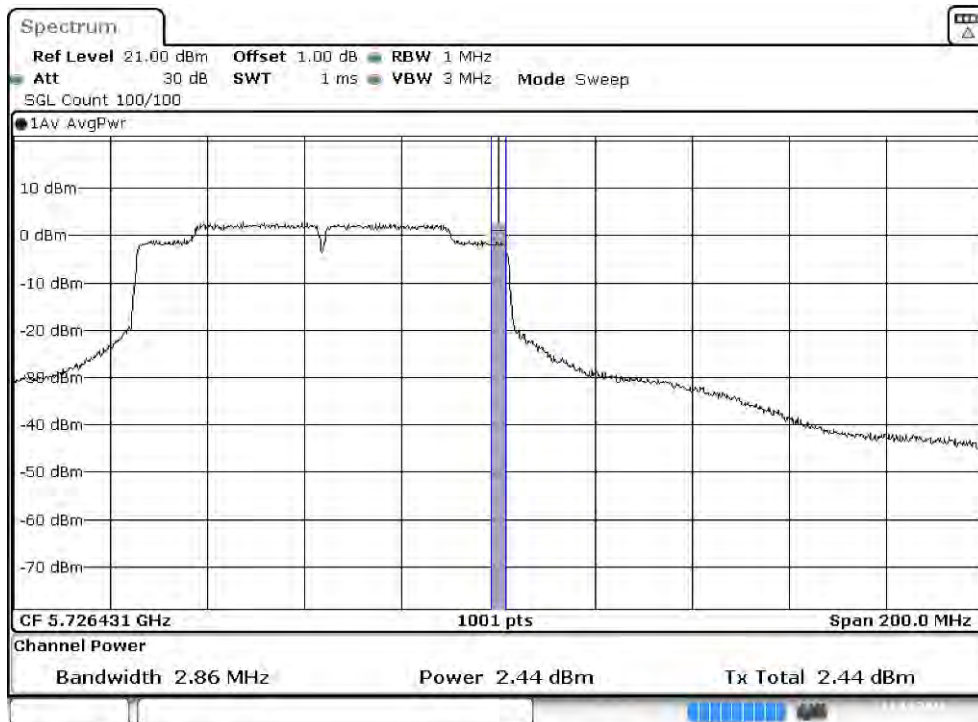

Maximum conducted output power:

Channel 155

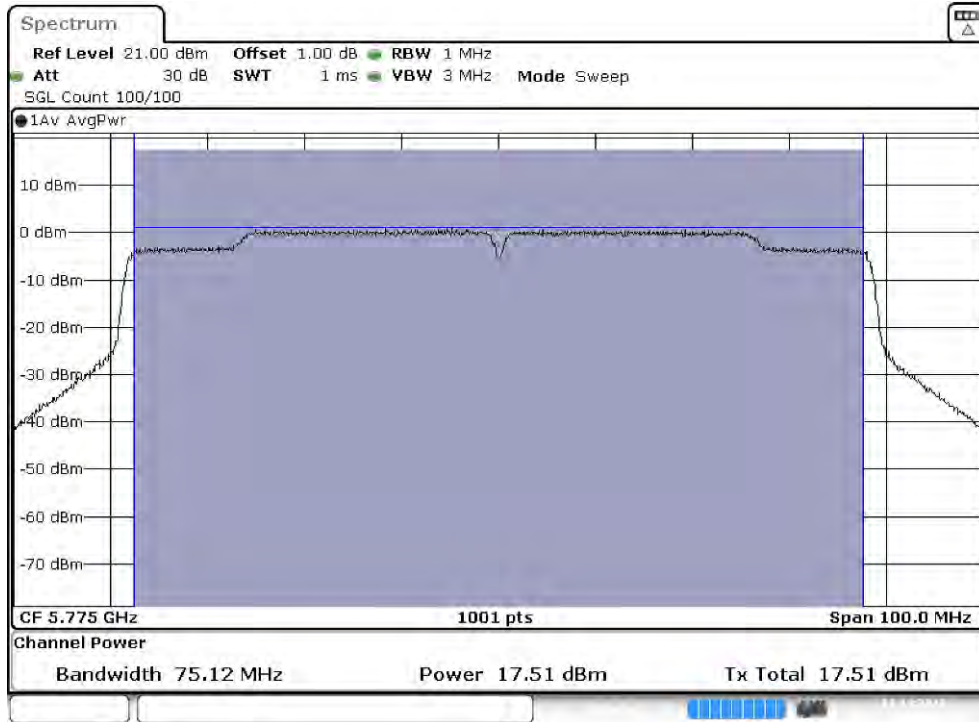

Product : Intel® Wireless-AC 9560
 Test Item : Maximum conducted output power
 Test Date : 2019/12/03
 Test Mode : Mode 5 SISO A: Transmit (802.11ac-160BW_65Mbps)

Cable loss=1.0dB		Maximum conducted output power									
Channel No	Frequency (MHz)	Data Rate (Mbps)									
		65	130	195	260	390	520	585	650	780	866.7
50 (U-NII-1)	5250	10.61	10.58	10.52	10.47	10.40	10.35	10.28	10.23	10.19	10.13
50 (U-NII-2A)	5250	10.71	10.64	10.60	10.55	10.50	10.44	10.38	10.34	10.28	10.24
114	5570	13.61	13.55	13.50	13.46	13.40	13.36	13.30	13.24	13.21	13.18

Note: Maximum conducted output power Value =Reading value on Spectrum Analyzer + cable loss

Maximum conducted output power Measurement:

Channel No	Frequency Range (MHz)	26dB Bandwidth (MHz)	Output Power (dBm)	Output Power Limit		Result
				(dBm)	dBm+10log(BW)	
50 (U-NII-1)	5250	--	10.61	23.36	--	Pass
50 (U-NII-2A)	5250	82.600	10.71	23.63	29.80	Pass
114	5570	164.850	13.61	23.13	32.30	Pass

26dB Occupied Bandwidth: Channel 50

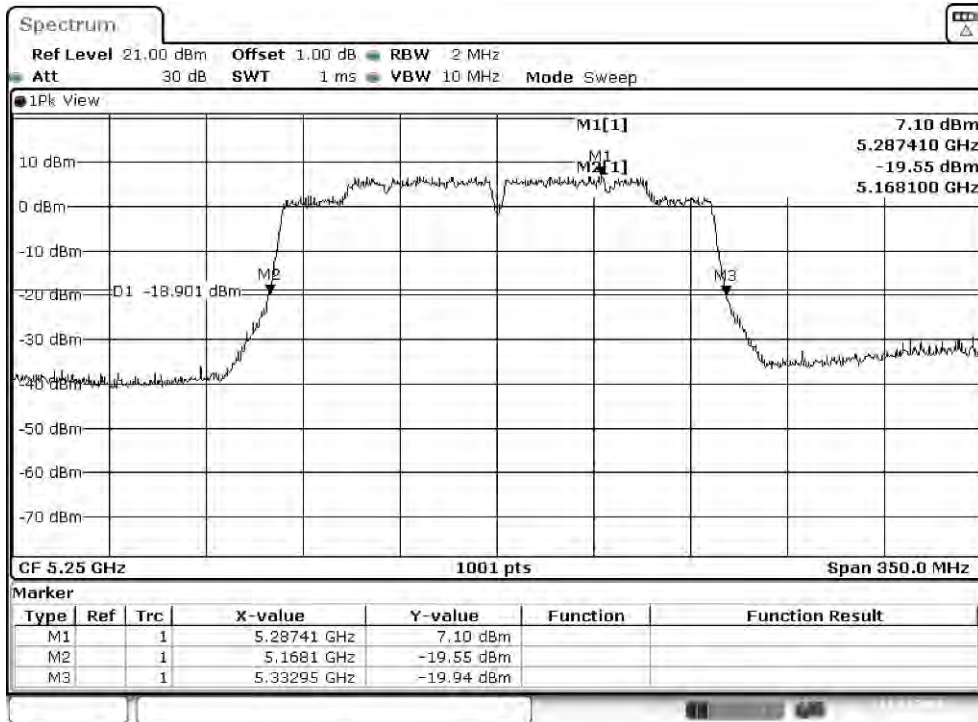

Channel 114

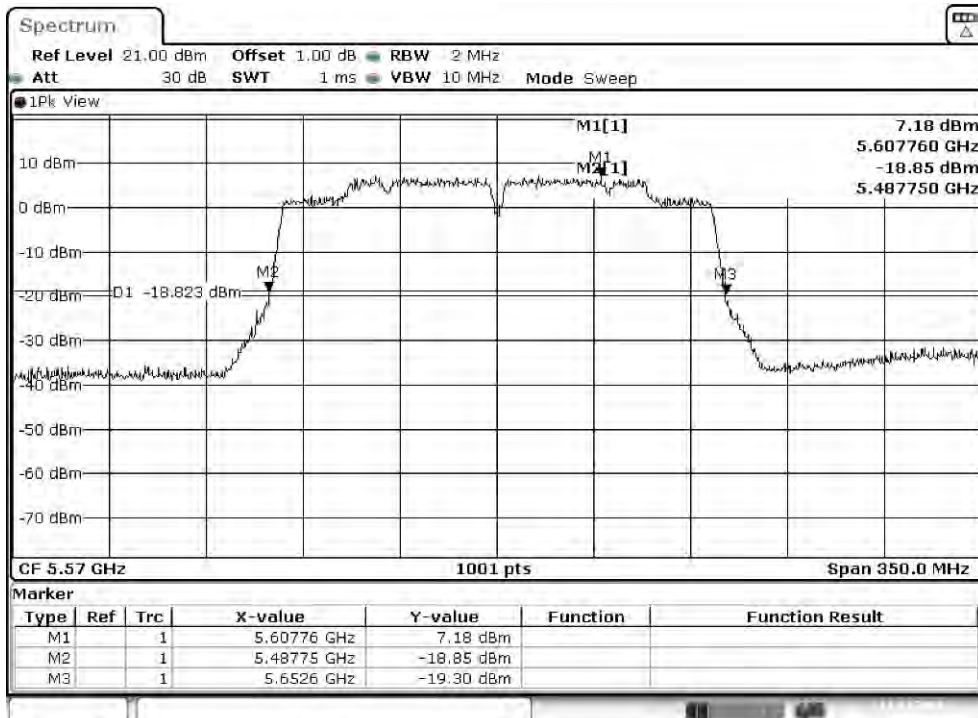

Maximum conducted output power:

Channel 50 (U-NII-1)

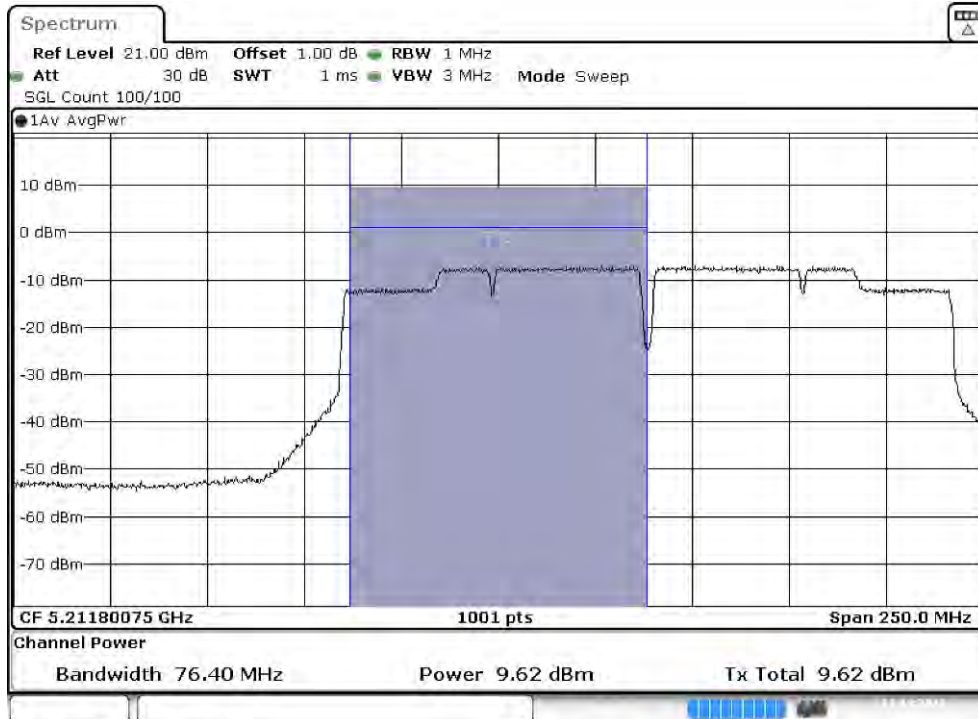

Maximum conducted output power:

Channel 50 (U-NII-2A)

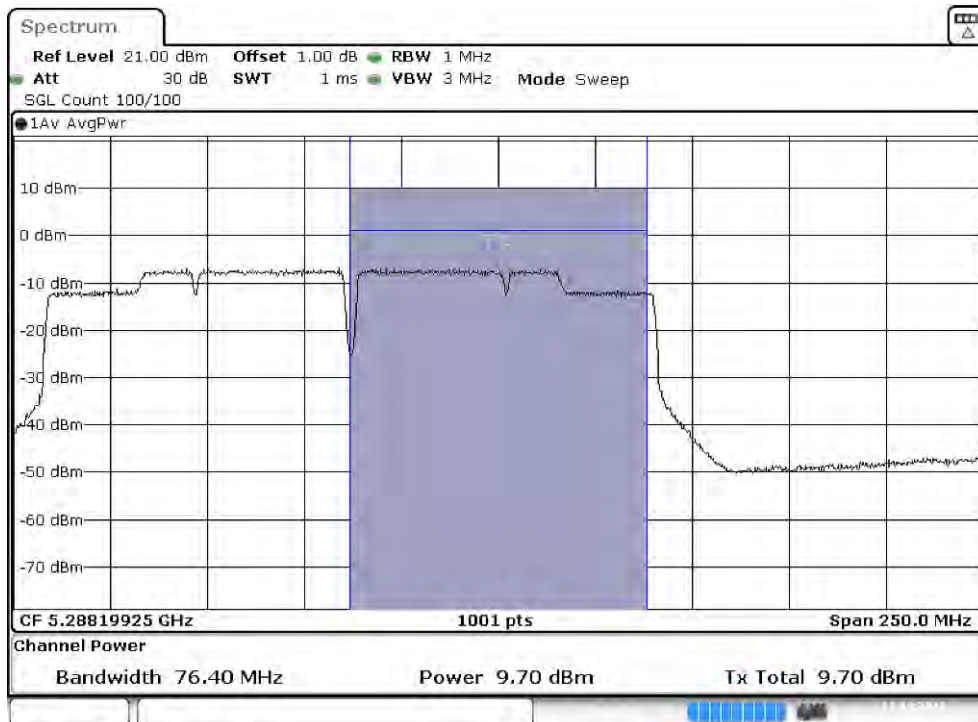

Maximum conducted output power:

Channel 114

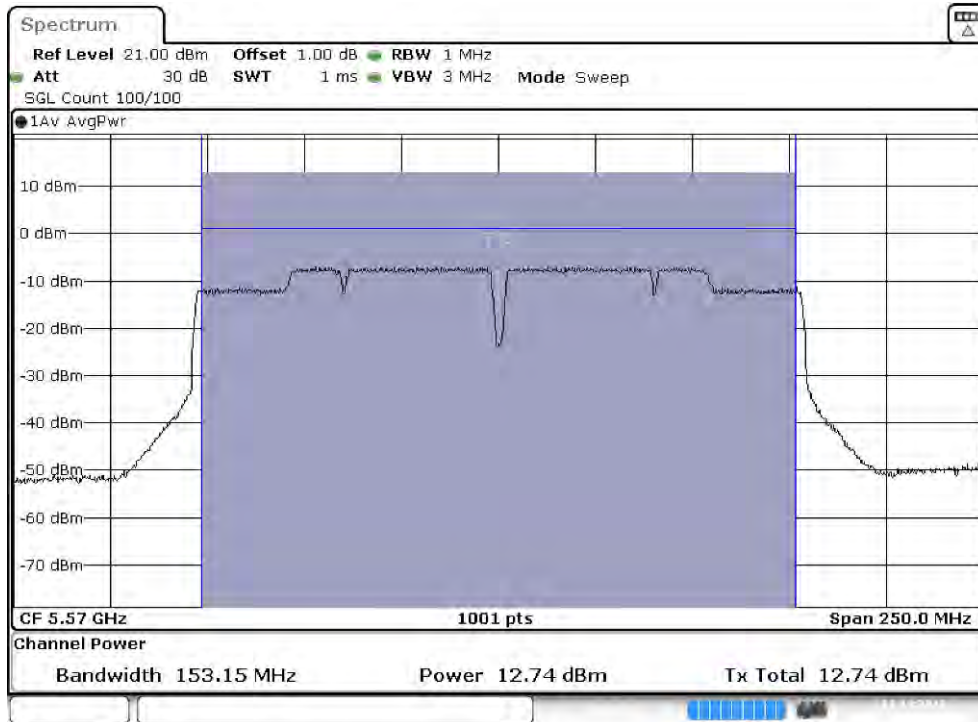

Product : Intel® Wireless-AC 9560
 Test Item : Maximum conducted output power
 Test Date : 2019/12/03
 Test Mode : Mode 6 SISO B: Transmit (802.11a_6Mbps)

Cable loss=1.0dB		Maximum conducted output power							
Channel No.	Frequency (MHz)	Data Rate (Mbps)							
		6	9	12	18	24	36	48	54
		Measurement Level (dBm)							
36	5180	18.15	--	--	--	--	--	--	--
44	5220	21.23	21.18	21.13	21.07	21.04	20.97	20.94	20.87
48	5240	20.73	--	--	--	--	--	--	--
52	5260	21.25	--	--	--	--	--	--	--
60	5300	21.33	21.27	21.23	21.18	21.11	21.05	21.01	20.96
64	5320	16.60	--	--	--	--	--	--	--
100	5500	15.27	--	--	--	--	--	--	--
116	5580	21.11	21.06	21.00	20.94	20.91	20.86	20.81	20.77
140	5700	16.46	--	--	--	--	--	--	--
149	5745	21.08	--	--	--	--	--	--	--
157	5785	21.03	20.99	20.94	20.90	20.85	20.79	20.73	20.68
165	5825	20.91	--	--	--	--	--	--	--

Note: Maximum conducted output power Value =Reading value on average power meter + cable loss

Maximum conducted output power Measurement:

Channel No	Frequency Range (MHz)	26dB Bandwidth (MHz)	Output Power (dBm)	Output Power Limit		Result
				(dBm)	dBm+10log(BW)	
36	5180	--	18.15	23.36	--	Pass
44	5220	--	21.23	23.36	--	Pass
48	5240	--	20.73	23.36	--	Pass
52	5260	36.900	21.25	23.63	26.30	Pass
60	5300	37.450	21.33	23.63	26.36	Pass
64	5320	23.250	16.60	23.63	24.29	Pass
100	5500	23.650	15.27	23.13	23.87	Pass
116	5580	33.700	21.11	23.13	25.41	Pass
140	5700	23.600	16.46	23.13	23.86	Pass
149	5745	--	21.08	29.71	--	Pass
157	5785	--	21.03	29.71	--	Pass
165	5825	--	20.91	29.71	--	Pass

26dB Occupied Bandwidth:

Channel 52

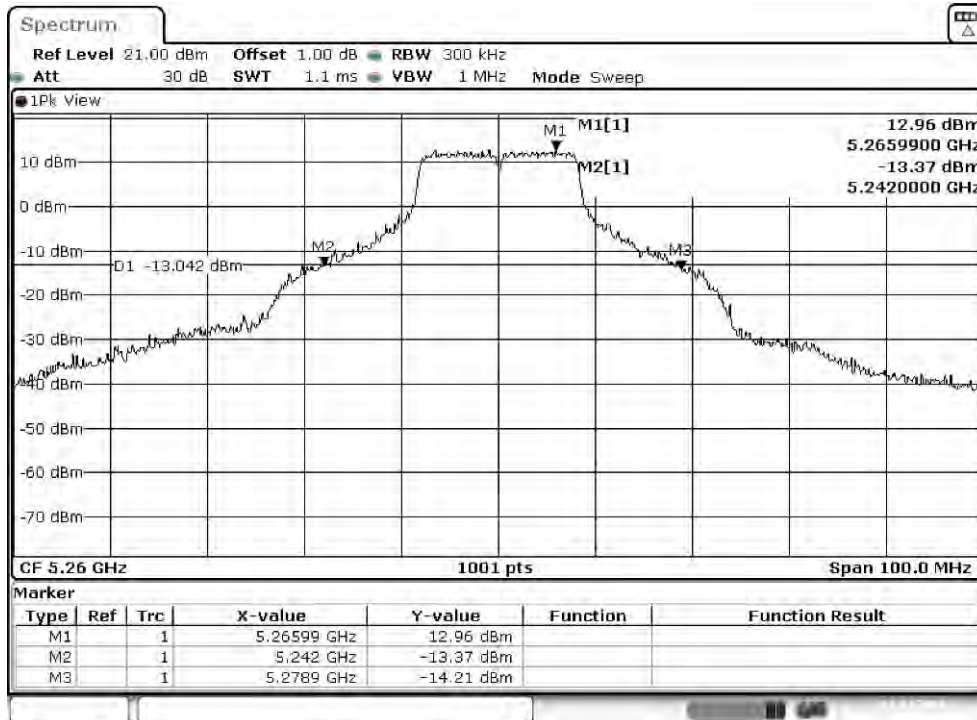

Channel 60

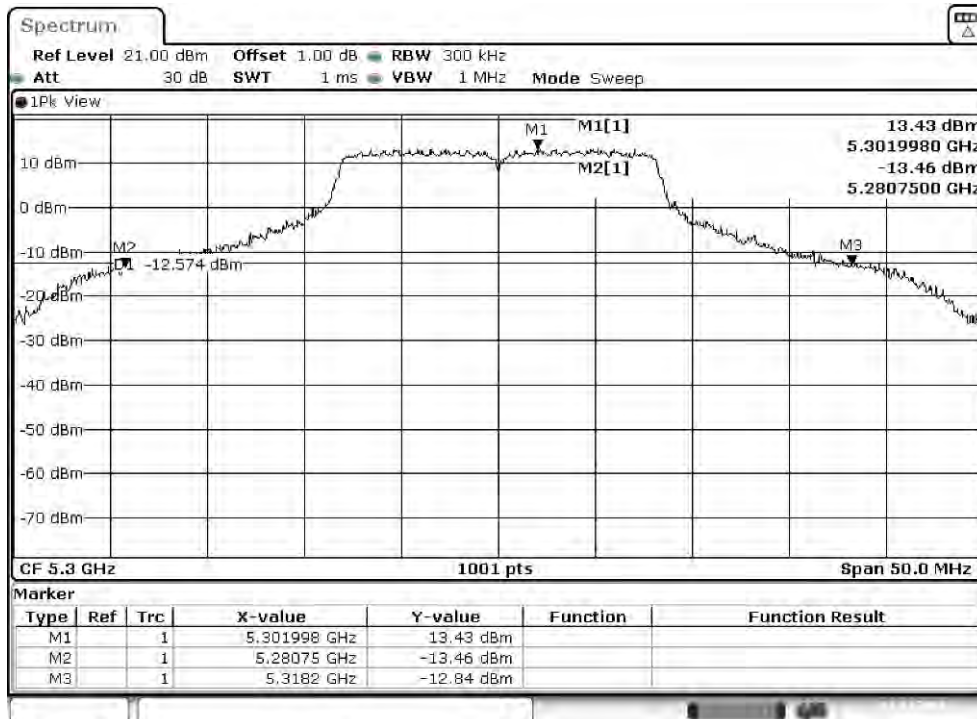

Channel 64

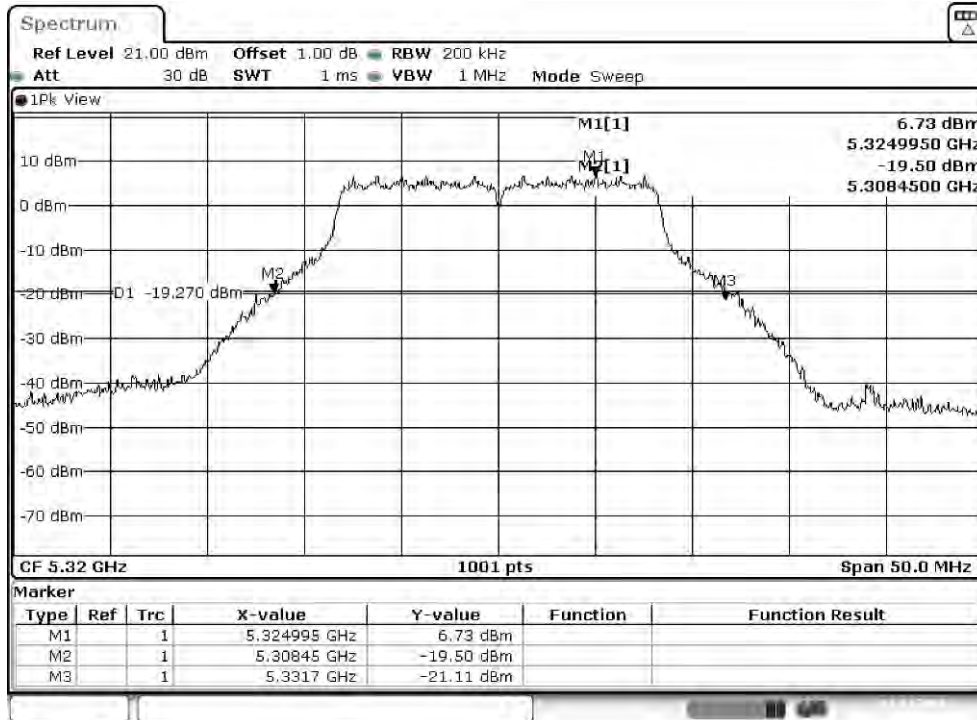

Channel 100

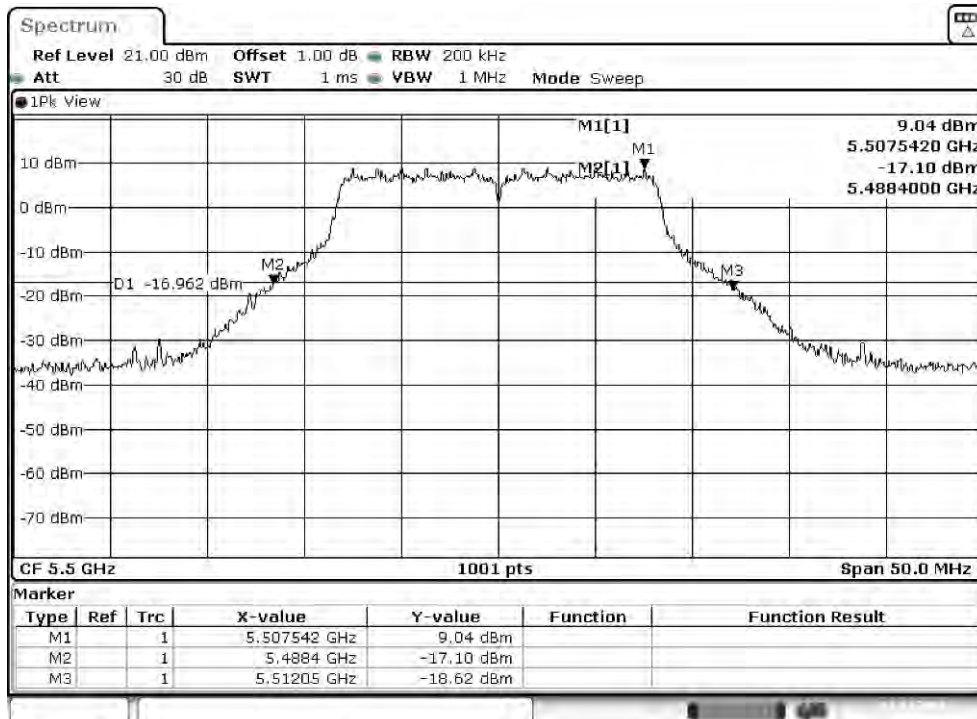

Channel 116

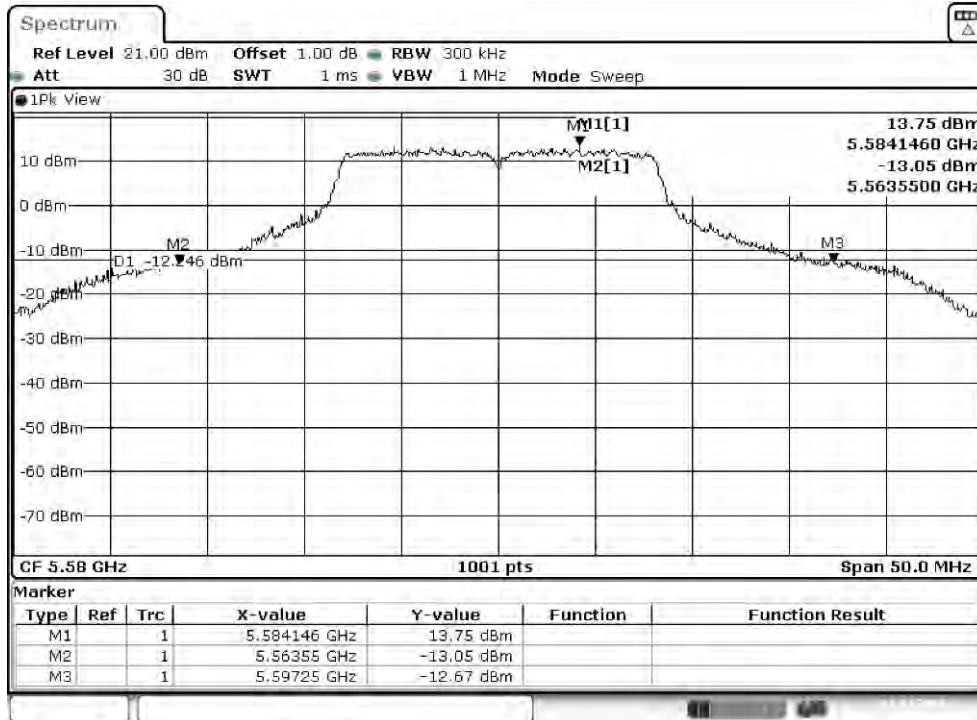

Channel 140

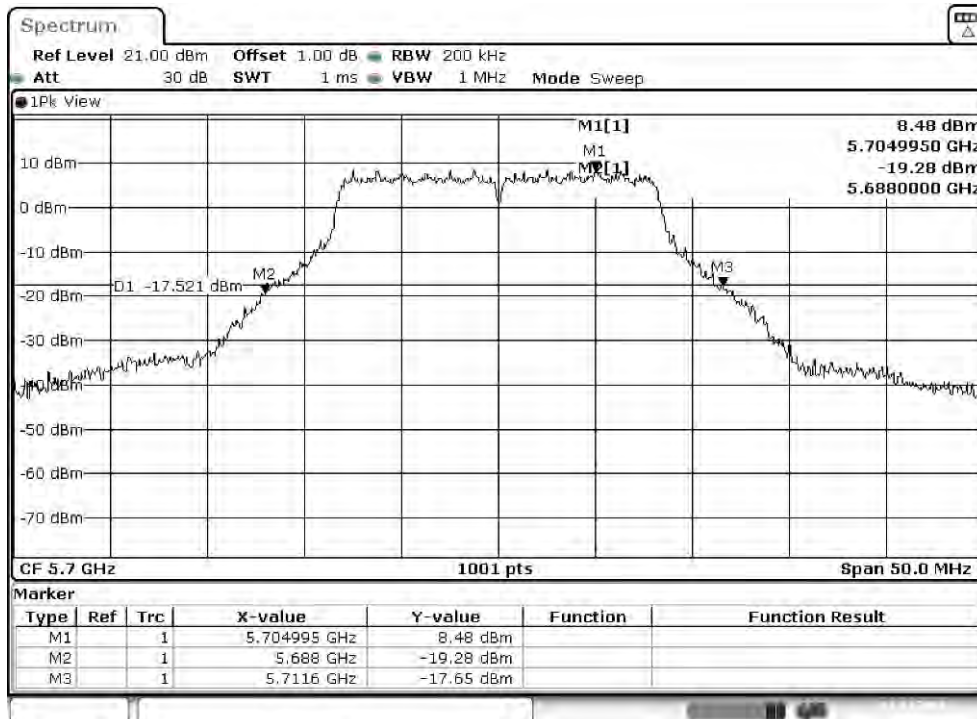

Product : Intel® Wireless-AC 9560
 Test Item : Maximum conducted output power
 Test Date : 2019/12/03
 Test Mode : Mode 7 SISO B: Transmit (802.11n-20BW_7.2Mbps)

Cable loss=1.0dB		Maximum conducted output power							
Channel No.	Frequency (MHz)	Data Rate (Mbps)							
		7.2	14.4	21.7	28.9	43.3	57.8	65	72.2
		Measurement Level (dBm)							
36	5180	17.71	--	--	--	--	--	--	--
44	5220	20.93	20.87	20.83	20.78	20.75	20.71	20.65	20.59
48	5240	20.32	--	--	--	--	--	--	--
52	5260	21.04	--	--	--	--	--	--	--
60	5300	21.22	21.18	21.14	21.09	21.05	20.99	20.92	20.86
64	5320	16.38	--	--	--	--	--	--	--
100	5500	15.27	--	--	--	--	--	--	--
116	5580	20.97	20.94	20.88	20.84	20.81	20.77	20.71	20.66
140	5700	16.16	--	--	--	--	--	--	--
144(U-NII-2C)	5720	19.74	19.70	19.66	19.59	19.53	19.48	19.44	19.40
144(U-NII-3)	5720	14.24	14.17	14.12	14.08	14.04	13.99	13.95	13.90
149	5745	20.74	--	--	--	--	--	--	--
157	5785	20.95	20.90	20.87	20.83	20.79	20.75	20.71	20.66
165	5825	20.91	--	--	--	--	--	--	--

Note: Maximum conducted output power Value =Reading value on average power meter + cable loss

Maximum conducted output power Measurement:

Channel No	Frequency Range (MHz)	26dB Bandwidth (MHz)	Output Power (dBm)	Output Power Limit		Result
				(dBm)	dBm+10log(BW)	
36	5180	--	17.71	23.36	--	Pass
44	5220	--	20.93	23.36	--	Pass
48	5240	--	20.32	23.36	--	Pass
52	5260	31.800	21.04	23.63	25.65	Pass
60	5300	36.450	21.22	23.63	26.25	Pass
64	5320	24.750	16.38	23.63	24.57	Pass
100	5500	23.400	15.27	23.13	23.82	Pass
116	5580	32.050	20.97	23.13	25.19	Pass
140	5700	25.100	16.16	23.13	24.13	Pass
144(U-NII-2C)	5720	18.686	19.74	23.13	22.85	Pass
144(U-NII-3)	5720	--	14.24	29.71	--	Pass
149	5745	--	20.74	29.71	--	Pass
157	5785	--	20.95	29.71	--	Pass
165	5825	--	20.91	29.71	--	Pass

26dB Occupied Bandwidth:

Channel 52

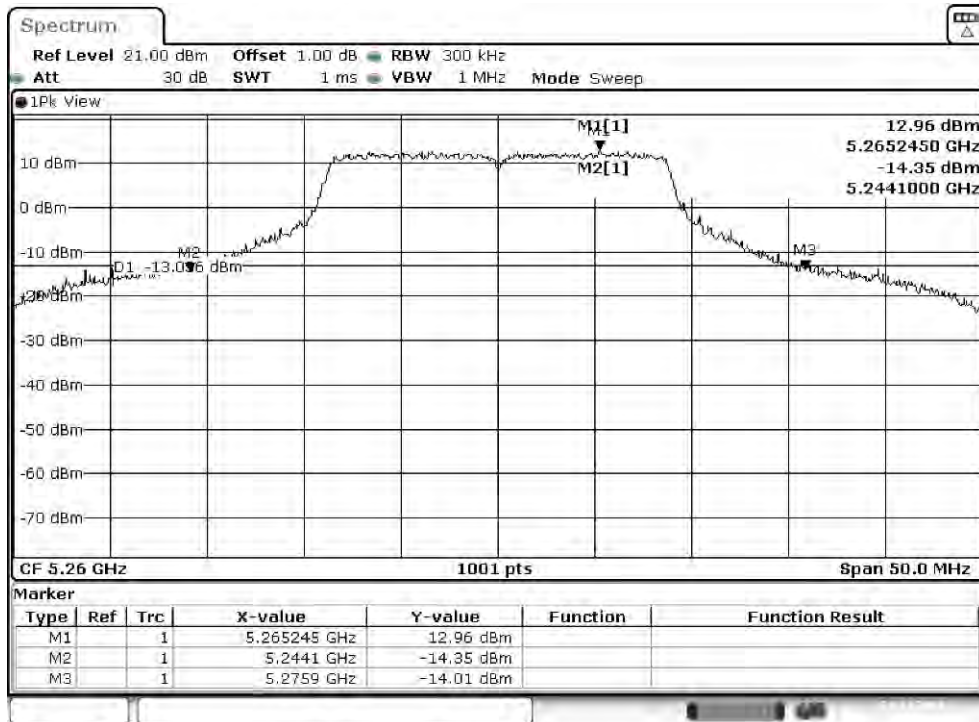

Channel 60

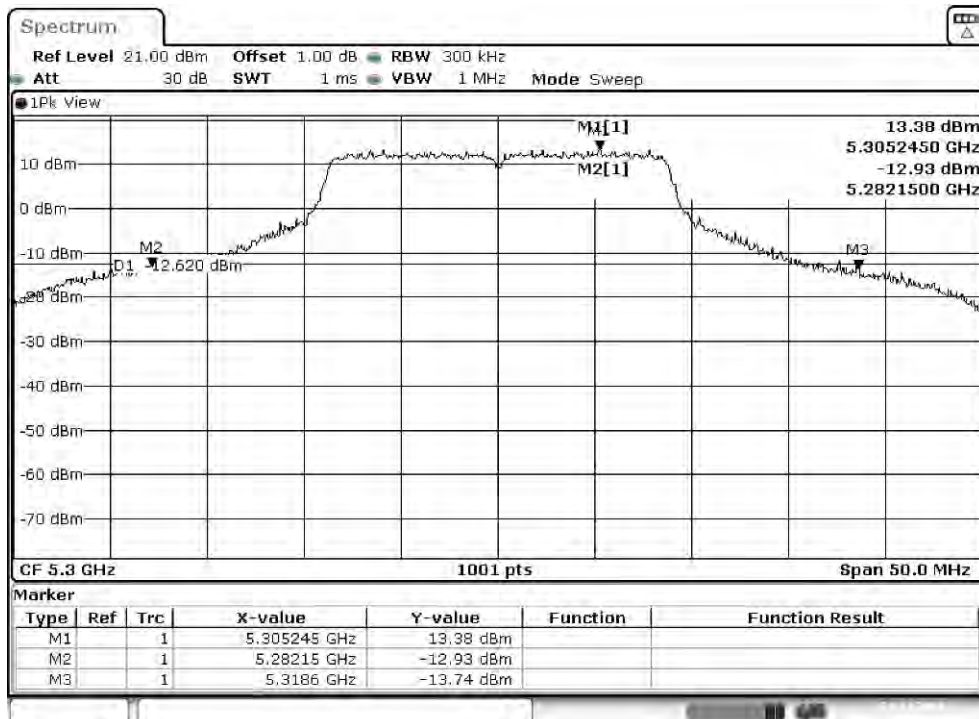

Channel 64

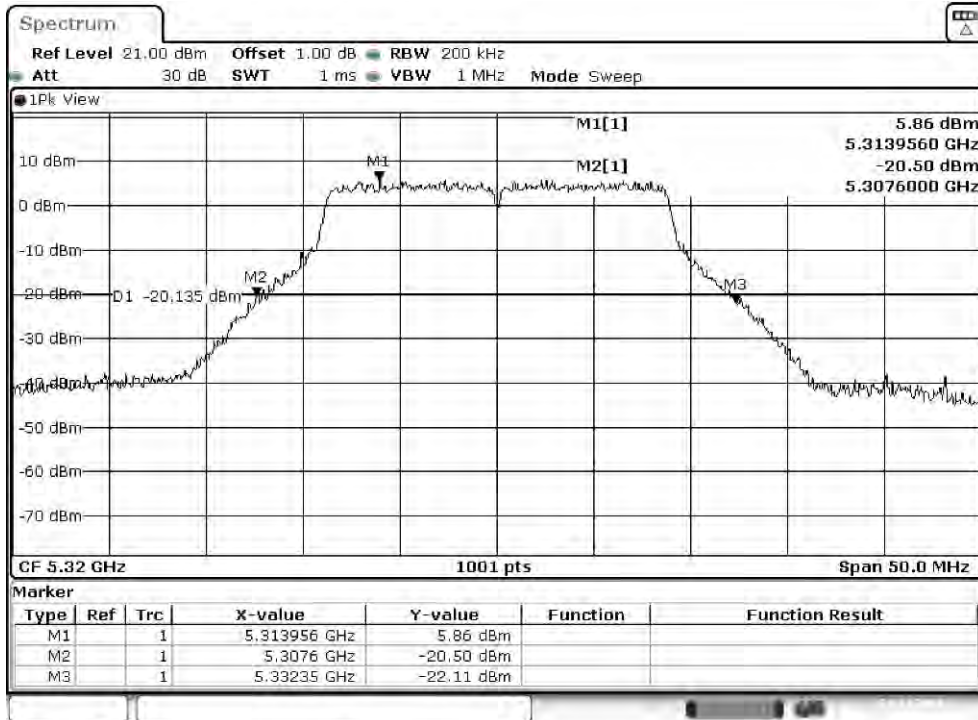

Channel 100

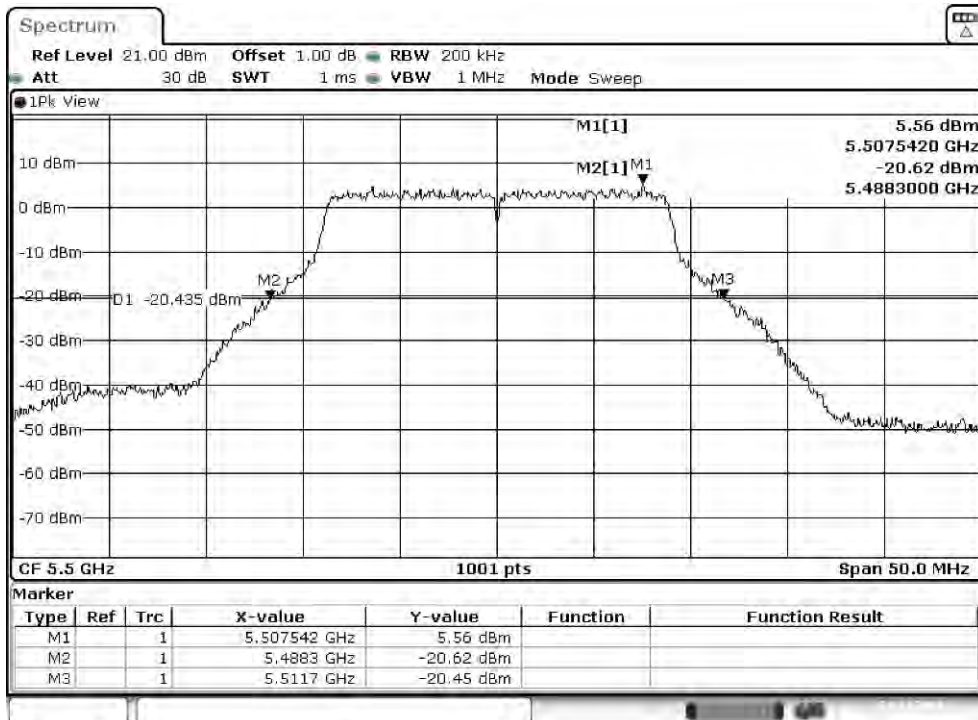

Channel 116

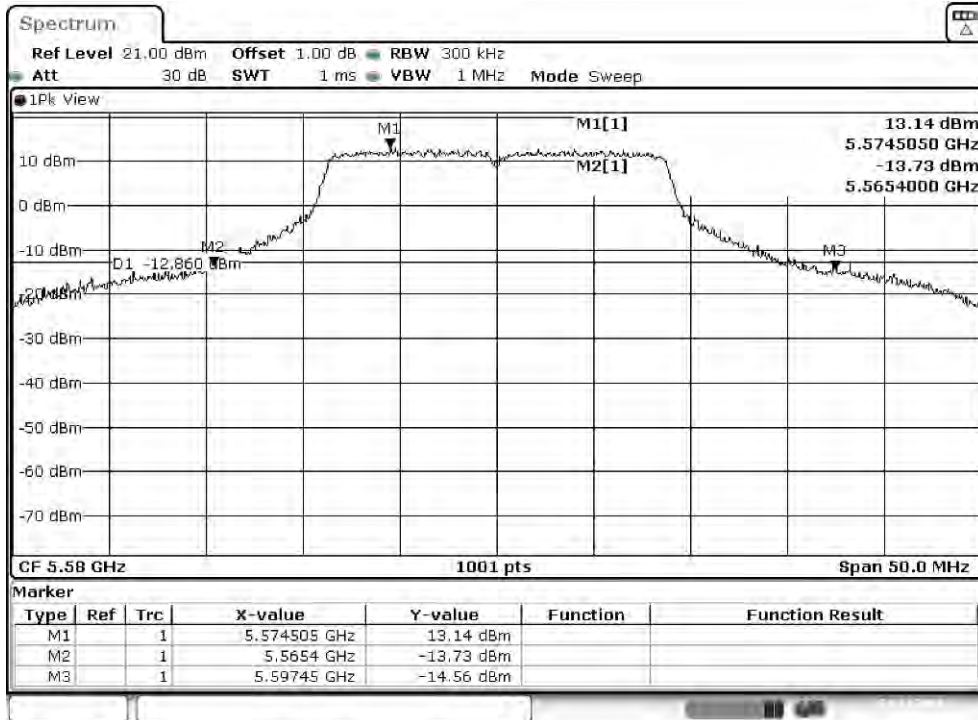

Channel 140

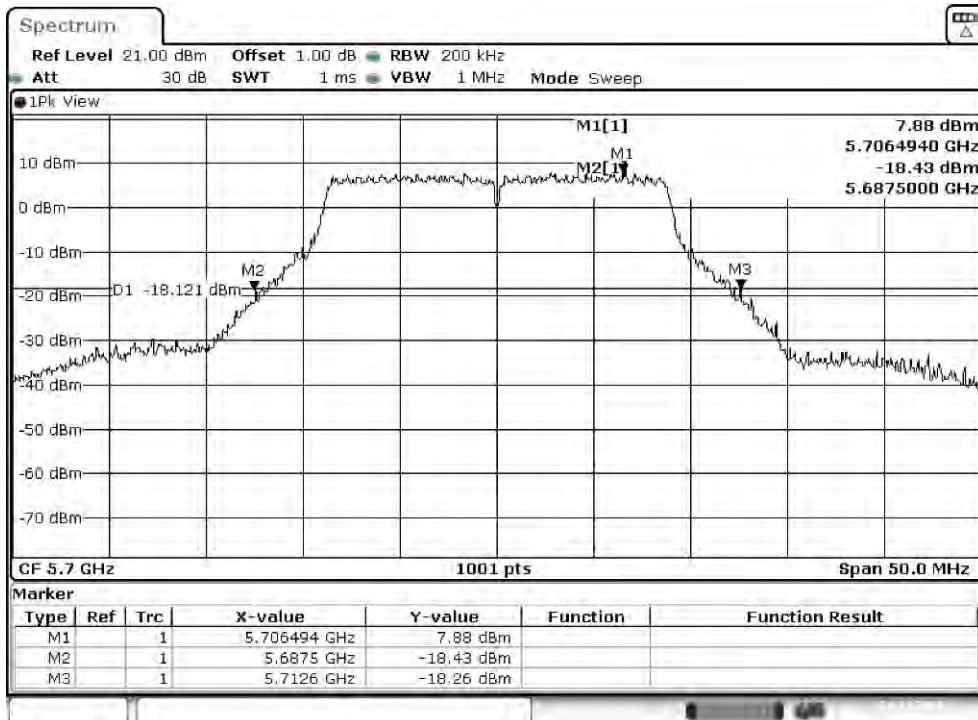

Channel 144

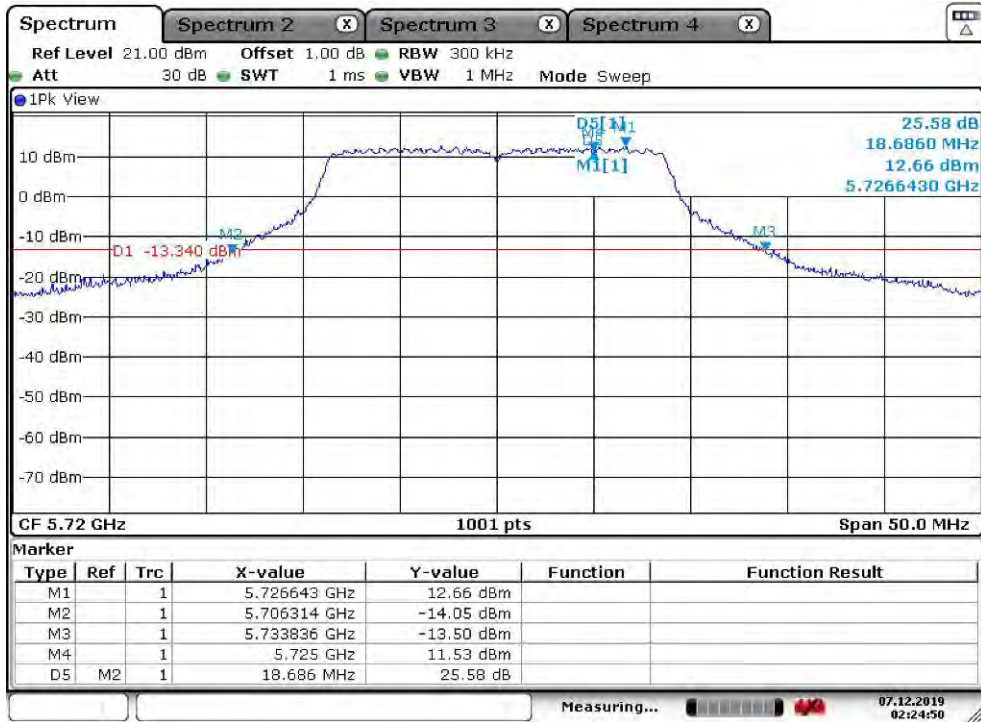

Maximum conducted output power:

Channel 144 (U-NII-2C)

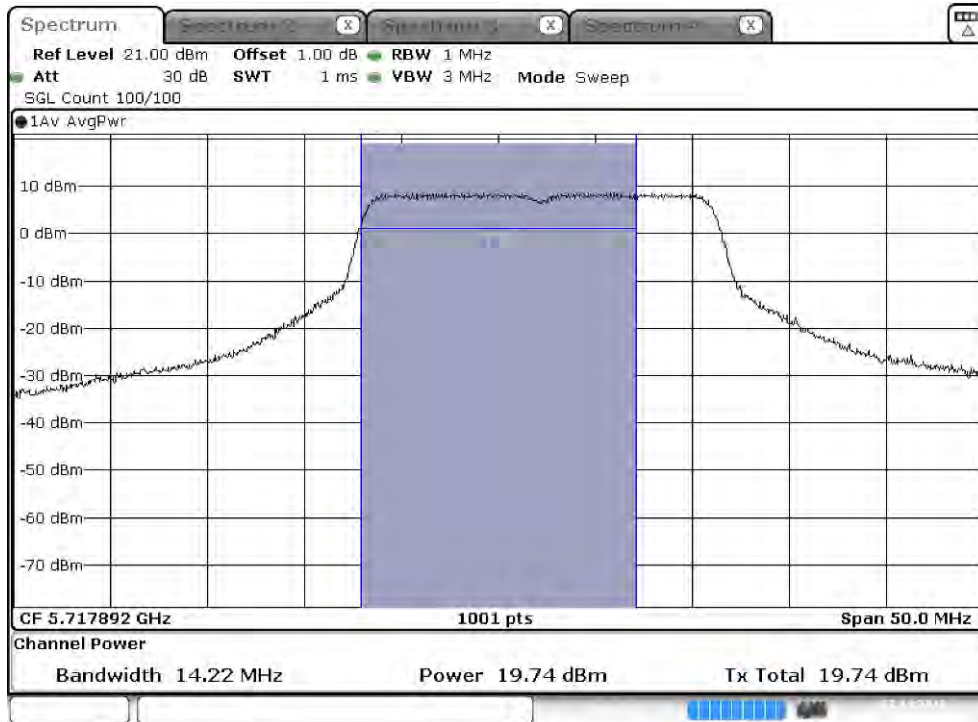

Maximum conducted output power:

Channel 144 (U-NII-3)



Product : Intel® Wireless-AC 9560
 Test Item : Maximum conducted output power
 Test Date : 2019/12/03
 Test Mode : Mode 8 SISO B: Transmit (802.11n-40BW_15Mbps)

Cable loss=1.0dB		Maximum conducted output power							
Channel No.	Frequency (MHz)	Data Rate (Mbps)							
		15	30	45	60	90	120	135	150
		Measurement Level (dBm)							
38	5190	17.36	--	--	--	--	--	--	--
46	5230	19.15	19.10	19.04	19.01	18.97	18.92	18.86	18.79
54	5270	18.47	--	--	--	--	--	--	--
62	5310	14.48	14.43	14.40	14.35	14.28	14.24	14.20	14.16
102	5510	15.66	--	--	--	--	--	--	--
110	5550	21.18	21.14	21.08	21.02	20.96	20.92	20.86	20.83
134	5670	17.50	--	--	--	--	--	--	--
142(U-NII-2C)	5710	19.62	19.55	19.50	19.43	19.38	19.32	19.25	19.22
142(U-NII-3)	5710	9.64	9.60	9.53	9.48	9.42	9.36	9.30	9.26
151	5755	18.49	--	--	--	--	--	--	--
159	5795	19.61	19.55	19.51	19.45	19.39	19.35	19.28	19.22

Note: Maximum conducted output power Value =Reading value on average power meter + cable loss

Maximum conducted output power Measurement:

Channel No	Frequency Range (MHz)	26dB Bandwidth (MHz)	Output Power (dBm)	Output Power Limit		Result
				(dBm)	dBm+10log(BW)	
38	5190	--	17.36	23.36	--	Pass
46	5230	--	19.15	23.36	--	Pass
54	5270	43.600	18.47	23.63	27.02	Pass
62	5310	43.600	14.48	23.63	27.02	Pass
102	5510	45.200	15.66	23.13	26.68	Pass
110	5550	92.850	21.18	23.13	29.81	Pass
134	5670	45.500	17.50	23.13	26.71	Pass
142(U-NII-2C)	5710	39.580	19.62	23.13	26.10	Pass
142(U-NII-3)	5710	--	9.64	29.71	--	Pass
151	5755	--	18.49	29.71	--	Pass
159	5795	--	19.61	29.71	--	Pass

26dB Occupied Bandwidth:

Channel 54

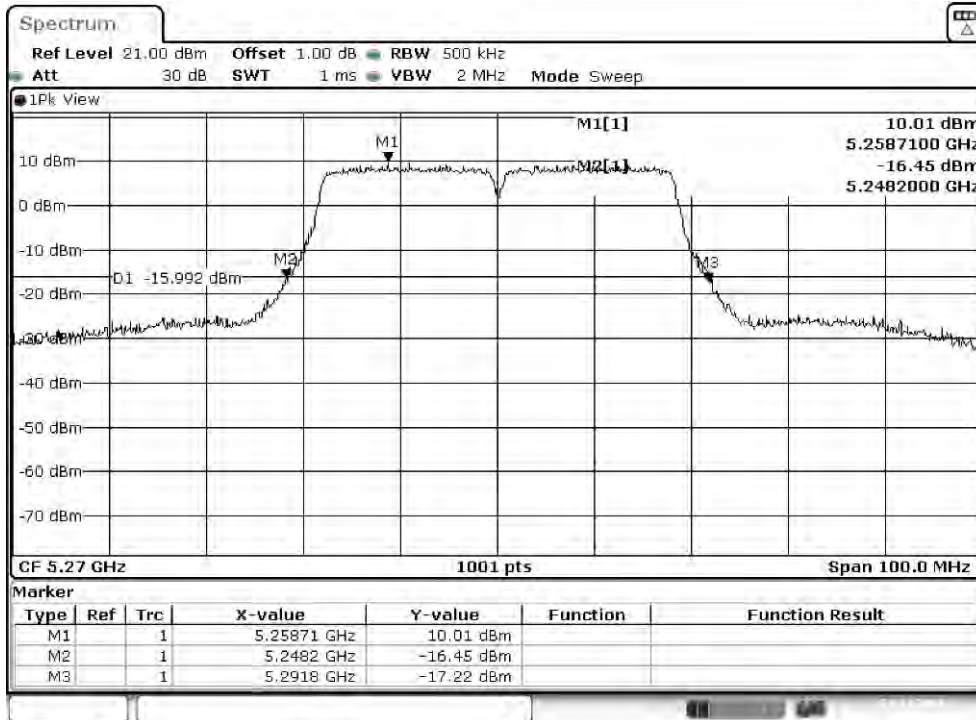

Channel 62

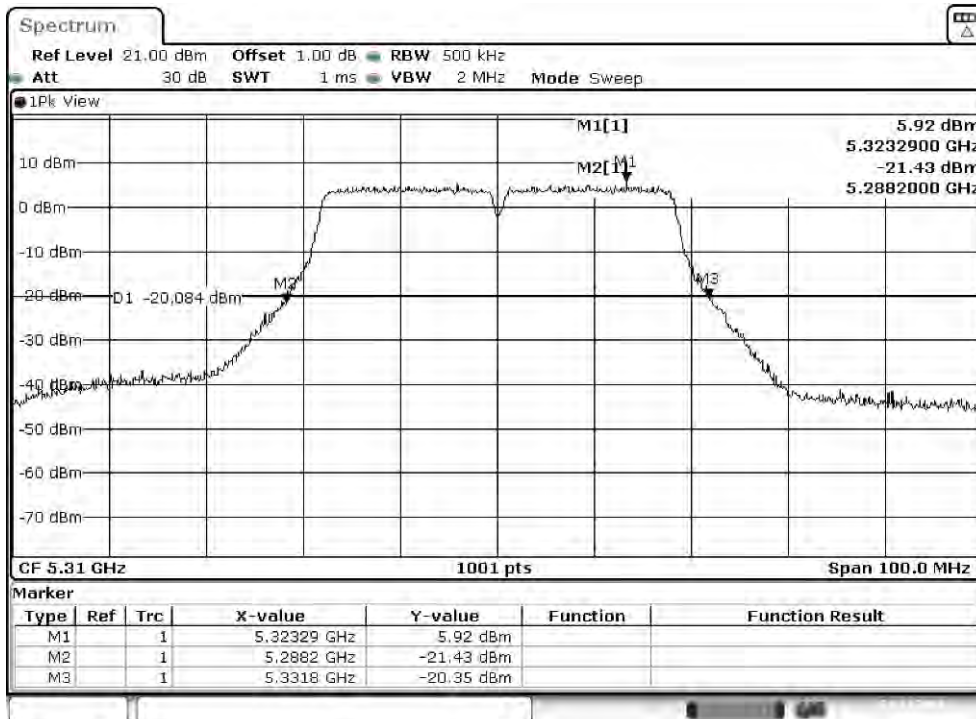

Channel 102

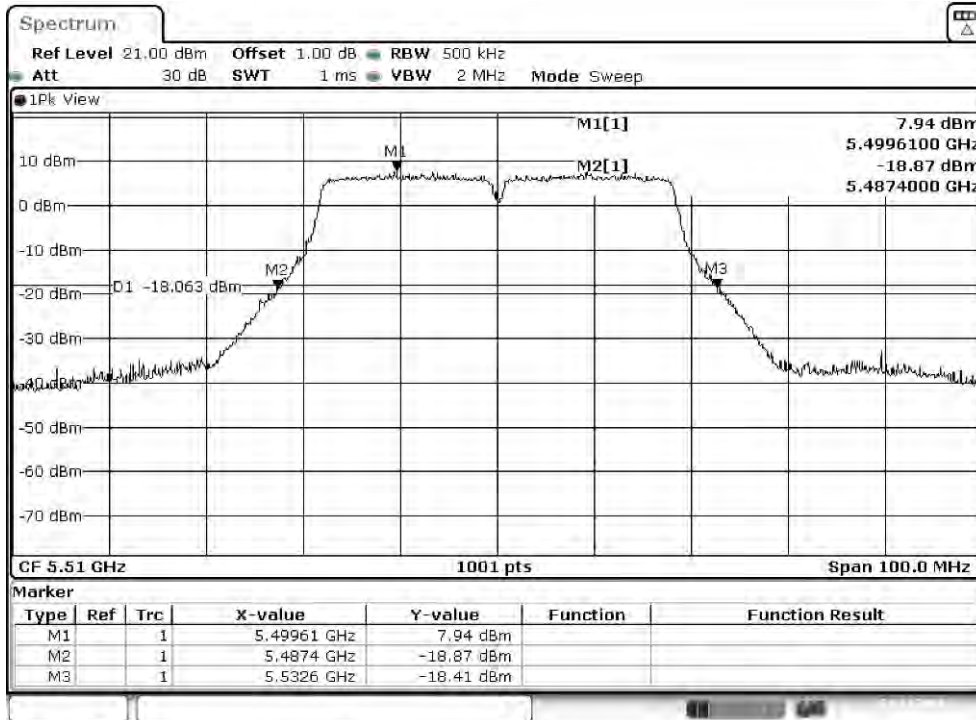

Channel 110

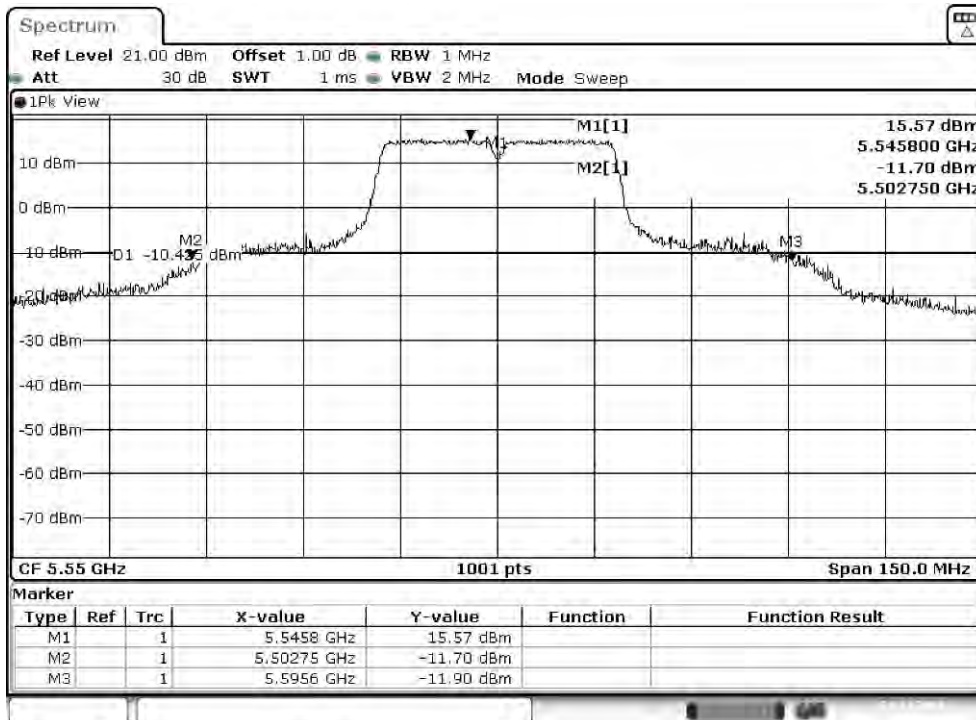

Channel 134

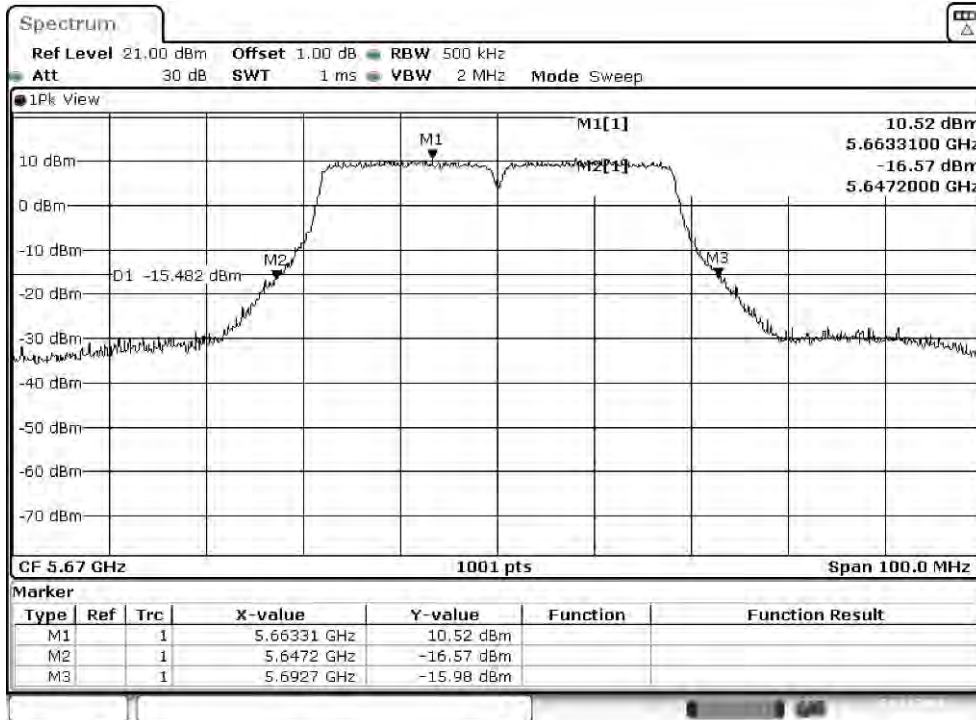

Channel 142

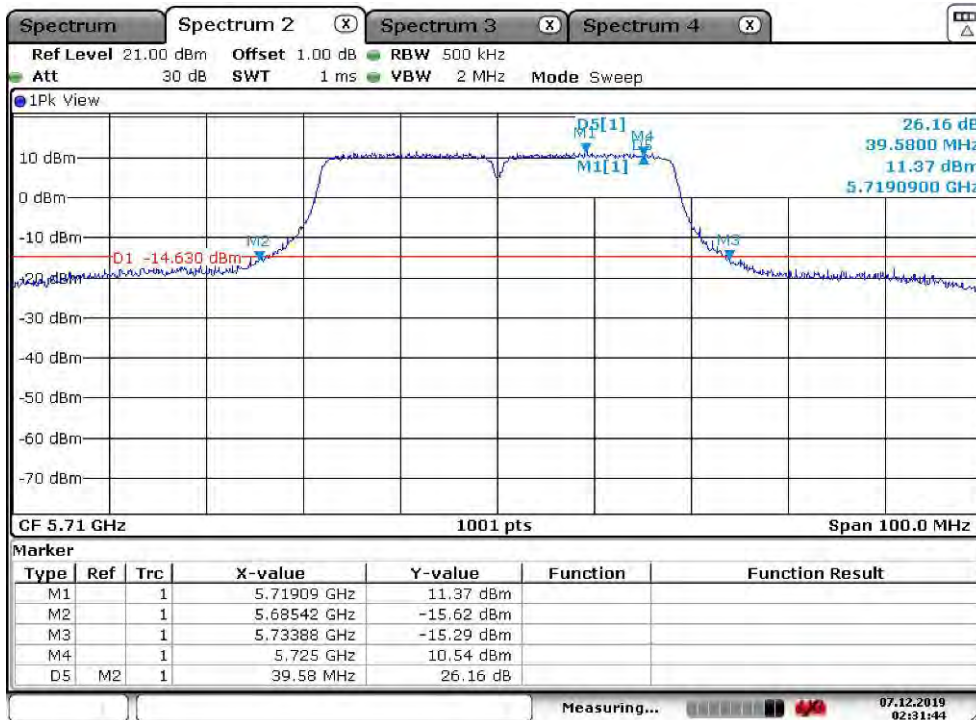

Maximum conducted output power:

Channel 142 (U-NII-2C)

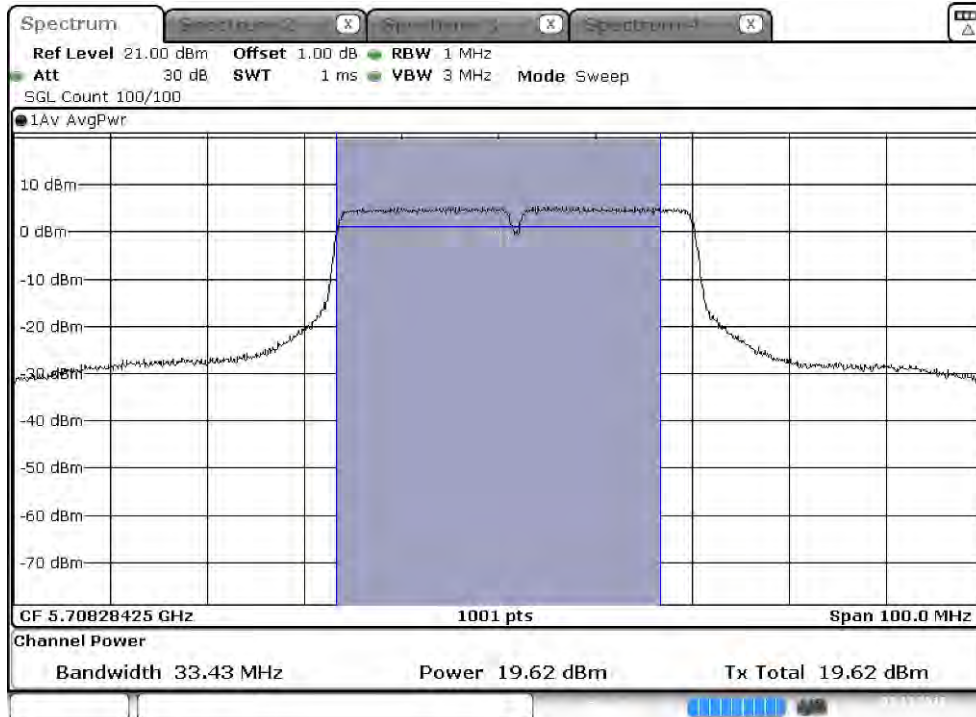

Maximum conducted output power:

Channel 142 (U-NII-3)

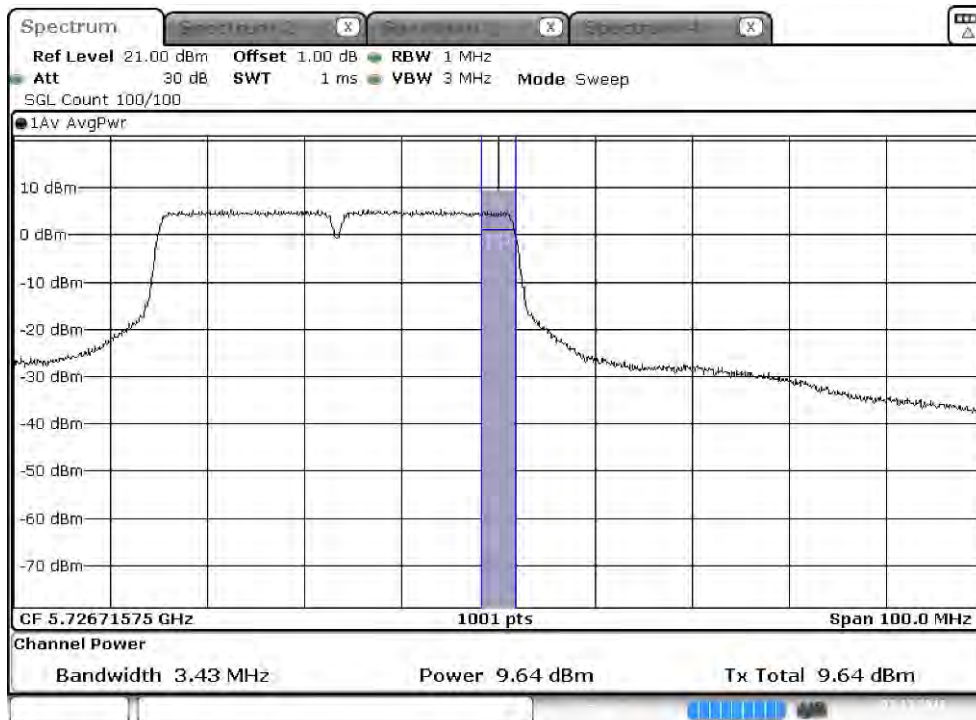

Product : Intel® Wireless-AC 9560
 Test Item : Maximum conducted output power
 Test Date : 2019/12/03
 Test Mode : Mode 9 SISO B: Transmit (802.11ac-80BW_32.5Mbps)

Cable loss=1.0dB		Maximum conducted output power									
Channel No	Frequency (MHz)	Data Rate (Mbps)									
		32.5	65	97.5	130	195	260	292.5	325	390	433.3
42	5210	16.57	16.51	16.45	16.38	16.31	16.25	16.18	16.14	16.10	16.05
58	5290	15.16	15.09	15.05	14.99	14.95	14.90	14.85	14.80	14.74	14.70
106	5530	16.12	--	--	--	--	--	--	--	--	--
122	5610	20.63	20.58	20.52	20.46	20.41	20.36	20.32	20.28	20.22	20.18
138 (U-NII-2C)	5690	20.29	--	--	--	--	--	--	--	--	--
138 (U-NII-3)	5690	4.15	--	--	--	--	--	--	--	--	--
155	5775	17.61	17.54	17.48	17.44	17.41	17.37	17.34	17.31	17.25	17.21

Note: Maximum conducted output power Value =Reading value on Spectrum Analyzer + cable loss

Maximum conducted output power Measurement:

Channel No	Frequency Range (MHz)	26dB Bandwidth (MHz)	Output Power (dBm)	Output Power Limit		Result
				(dBm)	dBm+10log(BW)	
42	5210	--	16.57	23.36	--	Pass
58	5290	87.200	15.16	23.63	30.04	Pass
106	5530	86.800	16.12	23.13	29.52	Pass
122	5610	123.800	20.63	23.13	31.06	Pass
138 (U-NII-2C)	5690	83.150	20.29	23.13	29.33	Pass
138 (U-NII-3)	5690	--	4.15	29.71	--	Pass
155	5775	--	17.61	29.71	--	Pass

26dB Occupied Bandwidth:

Channel 42

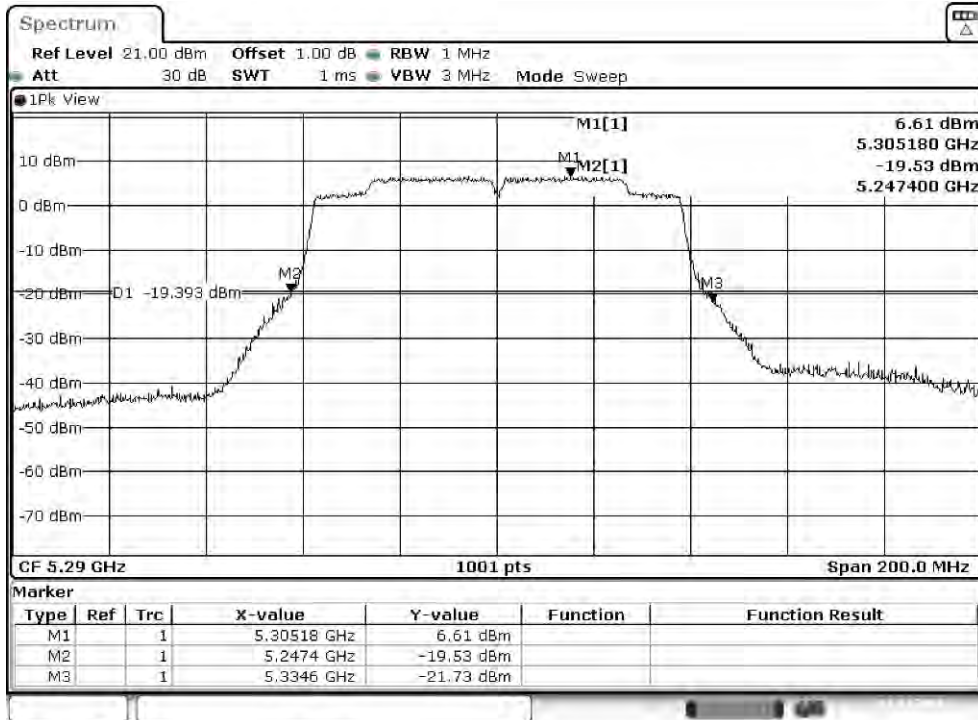

Channel 58

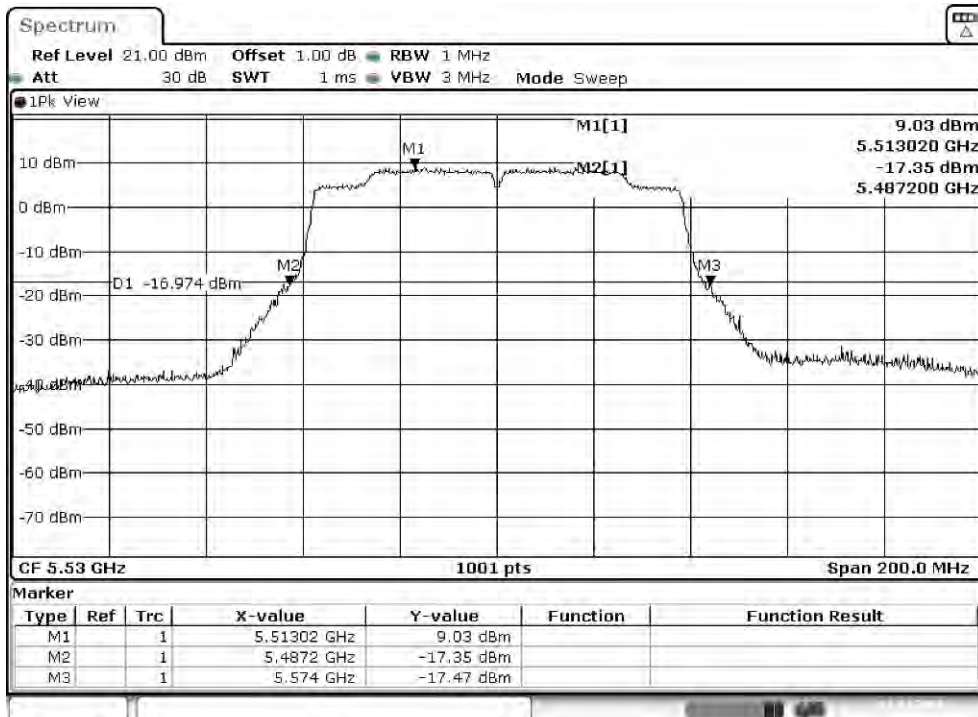

Channel 106

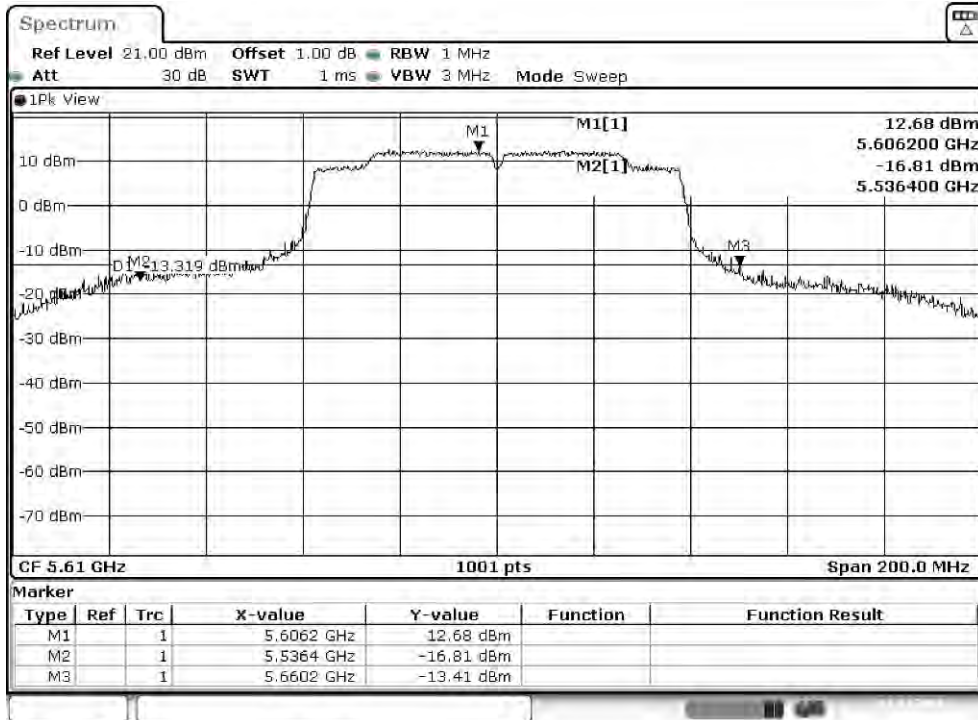

Channel 122

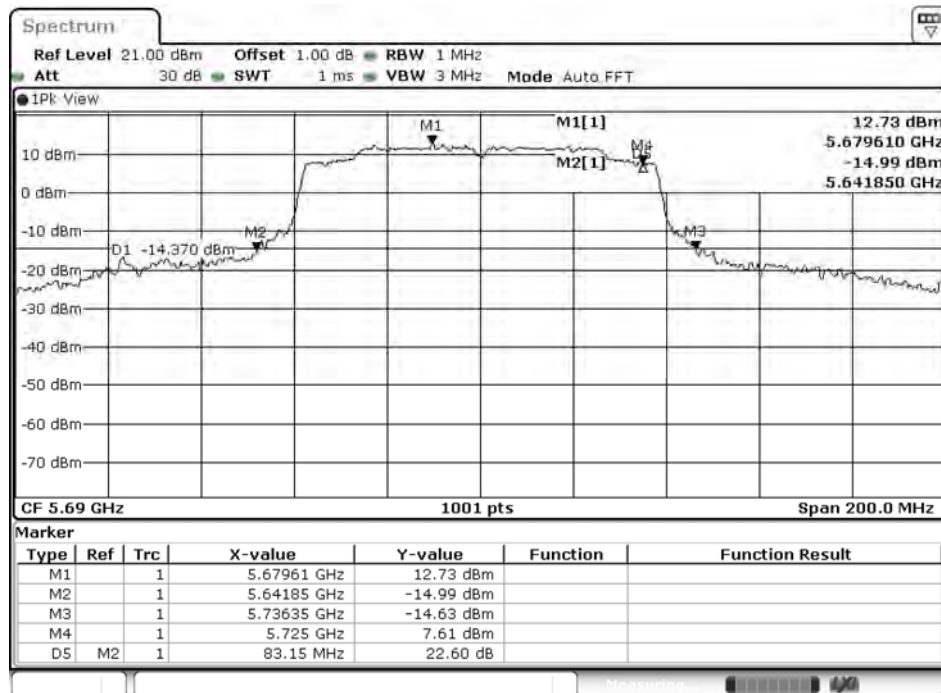

Date: 10.DEC.2019 22:31:13

Channel 138

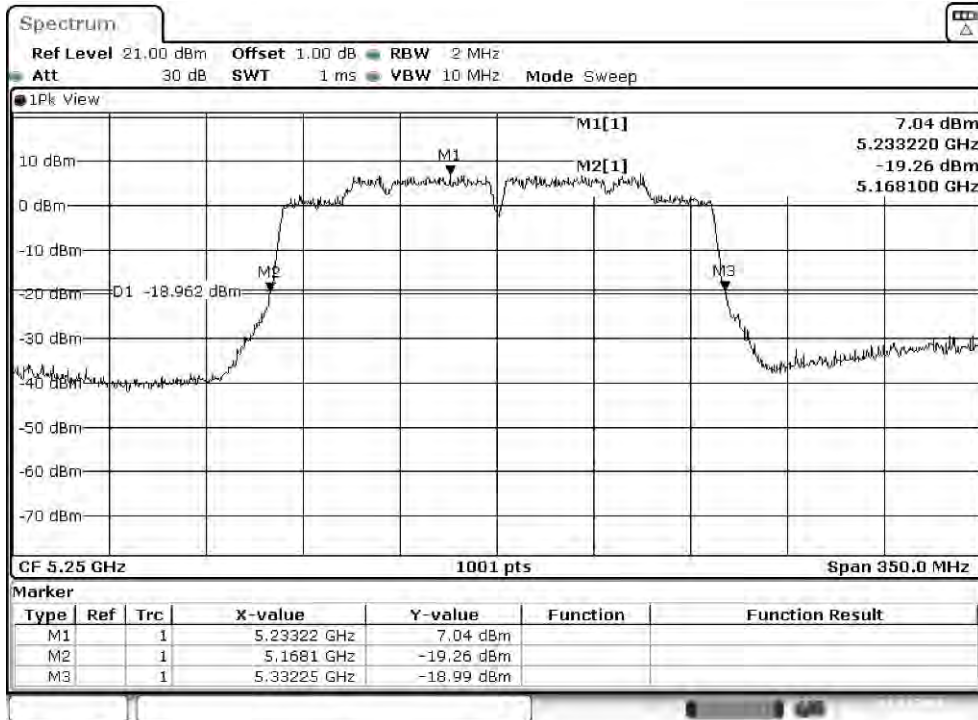

Channel 155

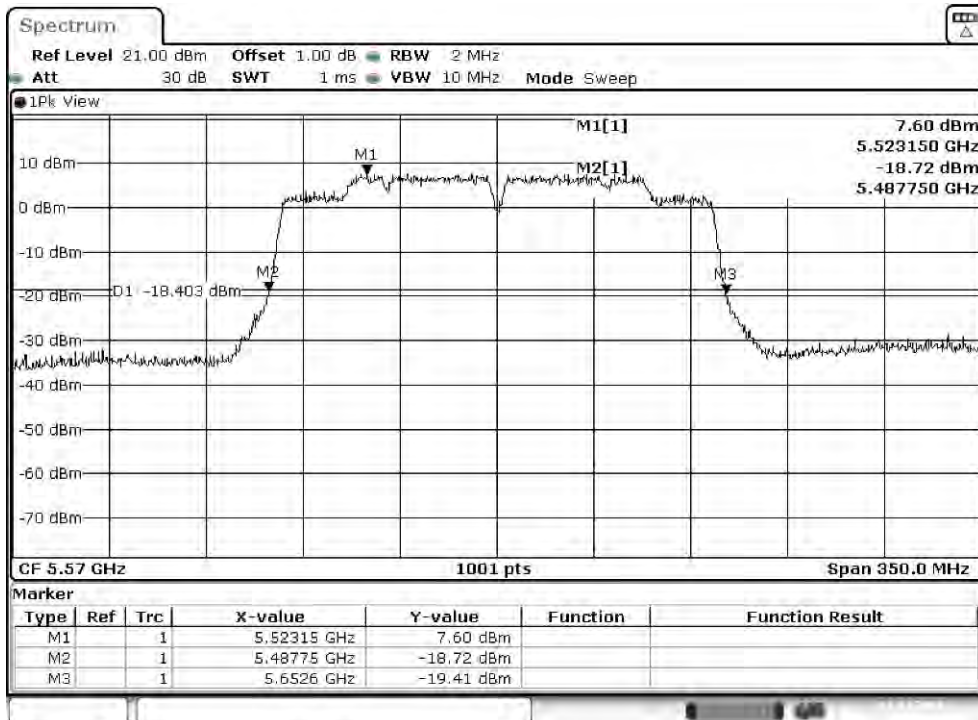

Maximum conducted output power:

Channel 138 (U-NII-2C)

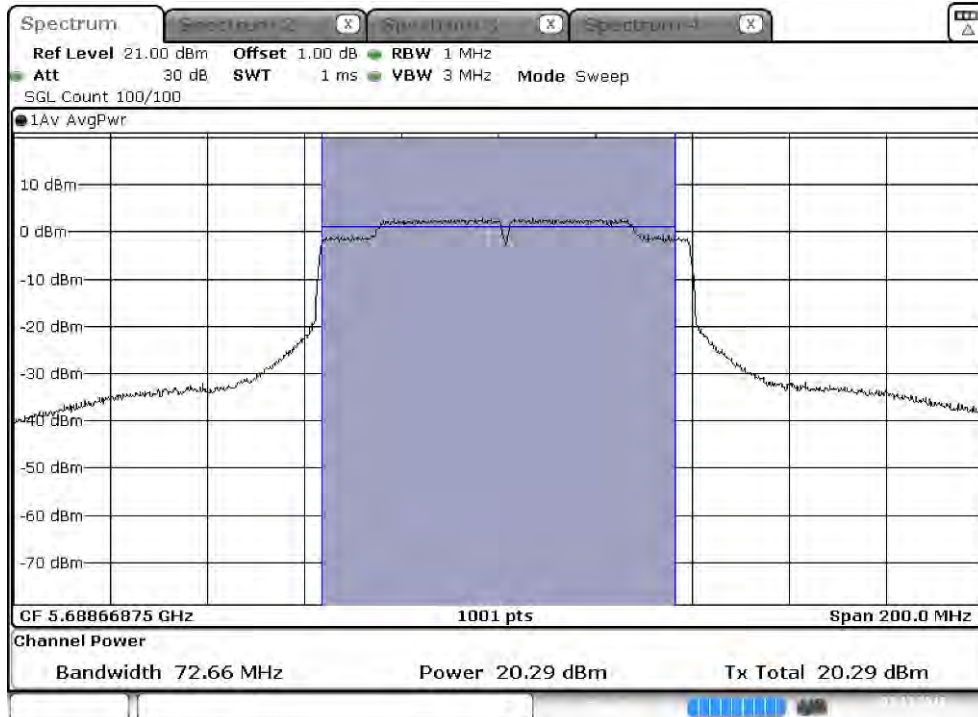

Maximum conducted output power:

Channel 138 (U-NII-3)

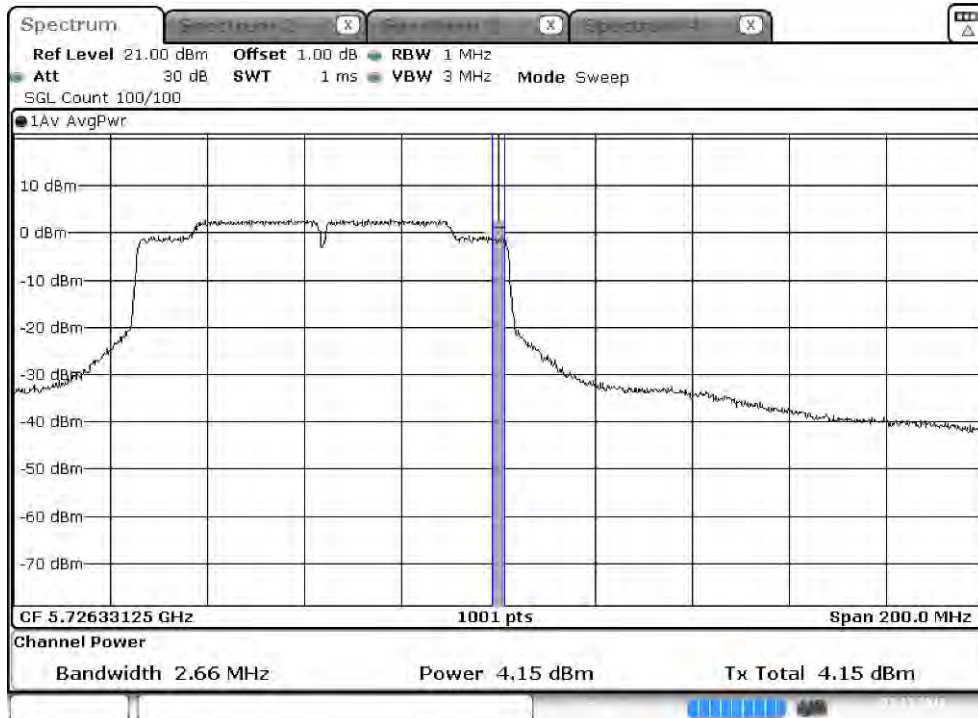

Product : Intel® Wireless-AC 9560
 Test Item : Maximum conducted output power
 Test Date : 2019/12/03
 Test Mode : Mode 10 SISO B: Transmit (802.11ac-160BW_65Mbps)

Cable loss=1.0dB		Maximum conducted output power									
Channel No	Frequency (MHz)	Data Rate (Mbps)									
		65	130	195	260	390	520	585	650	780	866.7
50 (U-NII-1)	5250	10.74	10.71	10.65	10.60	10.55	10.49	10.44	10.39	10.33	10.29
50 (U-NII-2A)	5250	10.84	10.79	10.74	10.69	10.64	10.59	10.54	10.47	10.41	10.36
114	5570	14.29	14.23	14.16	14.11	14.06	14.02	13.96	13.89	13.85	13.80

Note: Maximum conducted output power Value =Reading value on Spectrum Analyzer + cable loss

Maximum conducted output power Measurement:

Channel No	Frequency Range (MHz)	26dB Bandwidth (MHz)	Output Power (dBm)	Output Power Limit		Result
				(dBm)	dBm+10log(BW)	
50 (U-NII-1)	5250	--	10.74	23.36	--	Pass
50 (U-NII-2A)	5250	82.075	10.84	23.63	29.77	Pass
114	5570	164.850	14.29	23.13	32.30	Pass

26dB Occupied Bandwidth: Channel 50

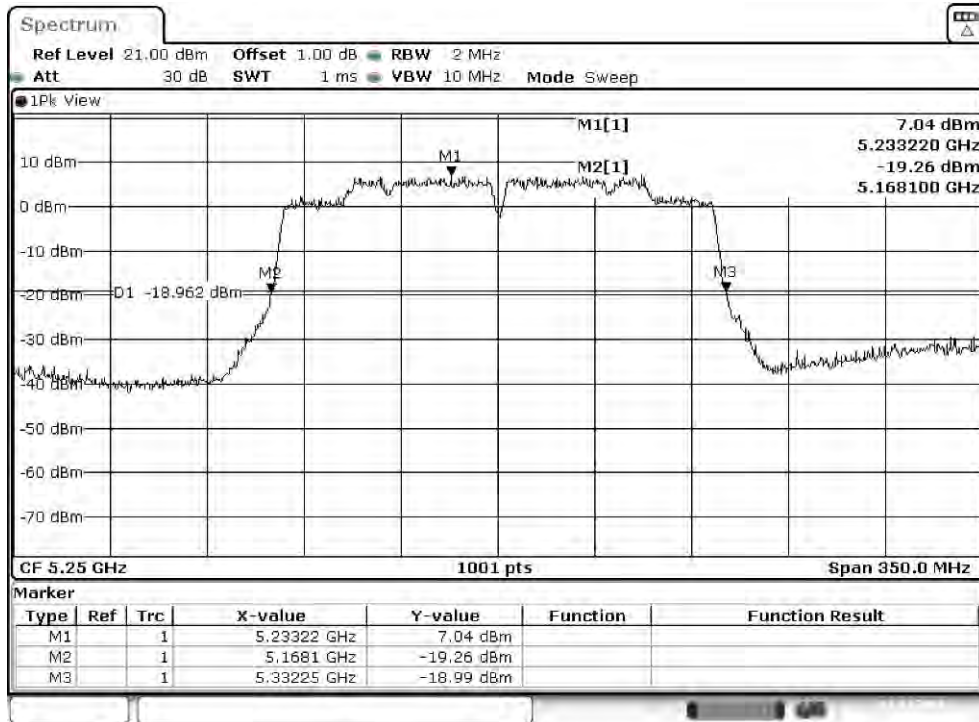

Channel 114

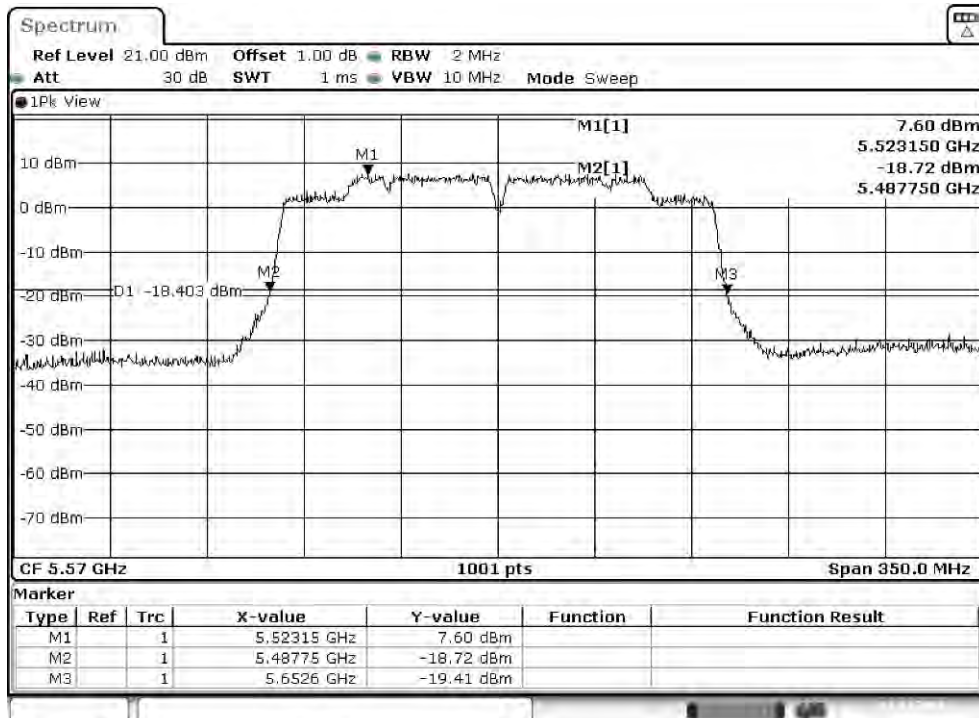

Maximum conducted output power:

Channel 50 (U-NII-1)

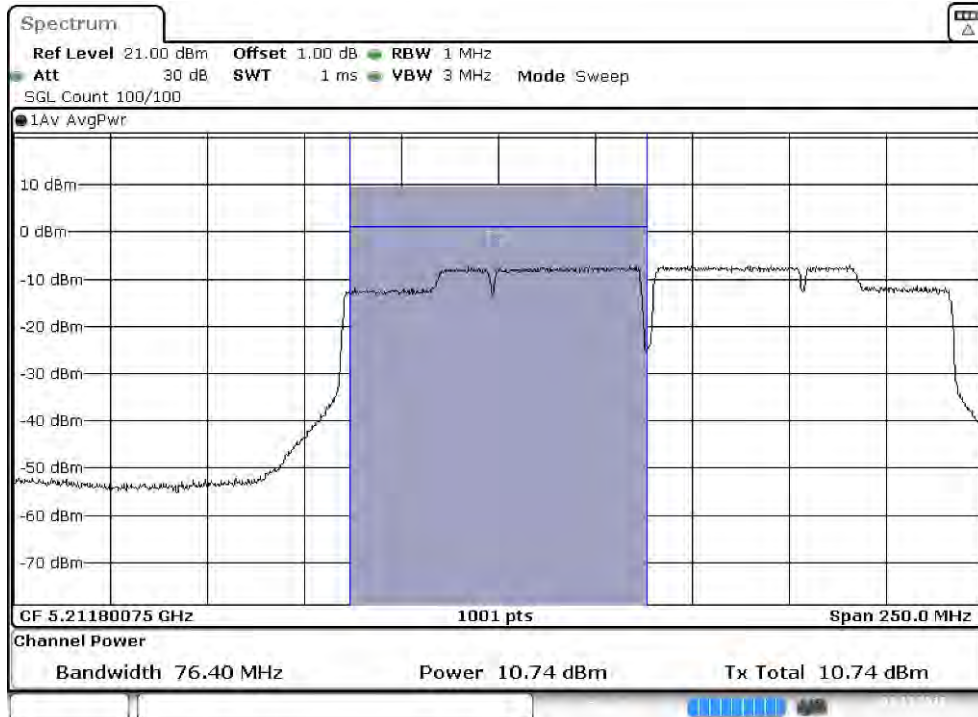

Maximum conducted output power:

Channel 50 (U-NII-2A)

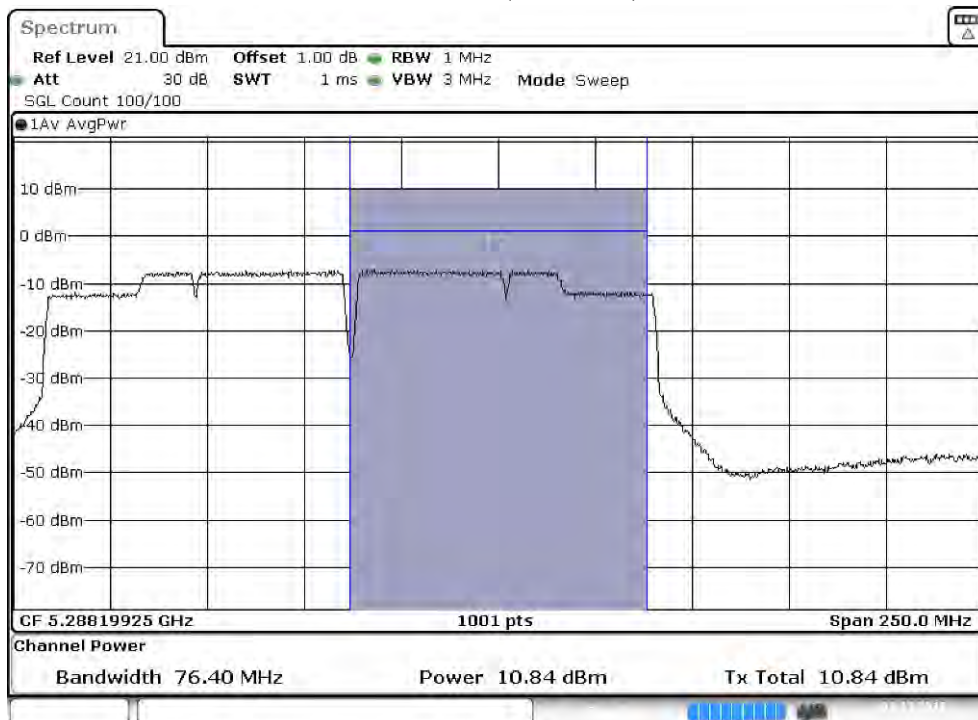

Product : Intel® Wireless-AC 9560
 Test Item : Maximum conducted output power
 Test Date : 2019/12/03
 Test Mode : Mode 11 MIMO: Transmit (802.11n-20BW_14.4Mbps)

Chain A

Cable loss=1.0dB		Maximum conducted output power							
Channel No.	Frequency (MHz)	Data Rate (Mbps)							
		14.4	28.9	43.3	57.8	86.7	115.6	130	144.4
36	5180	15.79	--	--	--	--	--	--	--
44	5220	19.45	19.39	19.36	19.31	19.25	19.21	19.16	19.10
48	5240	19.50	--	--	--	--	--	--	--
52	5260	19.56	--	--	--	--	--	--	--
60	5300	19.56	19.53	19.49	19.42	19.38	19.34	19.29	19.25
64	5320	15.73	--	--	--	--	--	--	--
100	5500	15.27	--	--	--	--	--	--	--
116	5580	19.64	19.59	19.55	19.48	19.42	19.38	19.34	19.30
140	5700	17.35	--	--	--	--	--	--	--
144(U-NII-2C)	5720	19.54	19.48	19.44	19.38	19.33	19.29	19.22	19.17
144(U-NII-3)	5720	13.07	13.04	13.00	12.97	12.93	12.90	12.84	12.80
149	5745	20.85	--	--	--	--	--	--	--
157	5785	20.81	20.75	20.69	20.65	20.59	20.53	20.48	20.43
165	5825	20.83	--	--	--	--	--	--	--

Note: Maximum conducted output power Value =Reading value on average power meter + cable loss

Chain B

Cable loss=1.0dB		Maximum conducted output power							
Channel No.	Frequency (MHz)	Data Rate (Mbps)							
		14.4	28.9	43.3	57.8	86.7	115.6	130	144.4
36	5180	15.65	--	--	--	--	--	--	--
44	5220	19.75	19.71	19.68	19.63	19.57	19.52	19.46	19.41
48	5240	19.67	--	--	--	--	--	--	--
52	5260	19.79	--	--	--	--	--	--	--
60	5300	19.56	19.50	19.43	19.39	19.35	19.30	19.24	19.18
64	5320	15.99	--	--	--	--	--	--	--
100	5500	15.49	--	--	--	--	--	--	--
116	5580	19.73	19.70	19.64	19.58	19.55	19.48	19.44	19.39
140	5700	17.85	--	--	--	--	--	--	--
144(U-NII-2C)	5720	19.30	19.27	19.21	19.15	19.12	19.06	19.01	18.96
144(U-NII-3)	5720	12.92	12.86	12.81	12.76	12.71	12.66	12.61	12.57
149	5745	20.83	--	--	--	--	--	--	--
157	5785	21.19	21.14	21.10	21.06	21.00	20.95	20.92	20.89
165	5825	21.03	--	--	--	--	--	--	--

Note: Maximum conducted output power Value =Reading value on average power meter + cable loss

Maximum conducted output power Measurement:

Channel No	Frequency Range (MHz)	26dB Bandwidth (MHz)	Chain A Power (dBm)	Chain B Power (dBm)	Output Power (dBm)	Output Power Limit		Result
						(dBm)	dBm+10log(BW)	
36	5180	--	15.79	15.65	18.73	23.36	--	Pass
44	5220	--	19.45	19.75	22.61	23.36	--	Pass
48	5240	--	19.5	19.67	22.60	23.36	--	Pass
52	5260	25.900	19.56	19.79	22.69	23.63	24.76	Pass
60	5300	25.450	19.56	19.56	22.57	23.63	24.69	Pass
64	5320	24.750	15.73	15.99	18.87	23.63	24.57	Pass
100	5500	24.100	15.27	15.49	18.39	23.13	23.95	Pass
116	5580	25.900	19.64	19.73	22.70	23.13	24.26	Pass
140	5700	23.950	17.35	17.85	20.62	23.13	23.92	Pass
144(U-NII-2C)	5720	17.537	19.54	19.3	22.43	23.13	22.57	Pass
144(U-NII-3)	5720	--	13.07	12.92	16.01	29.71	--	Pass
149	5745	--	20.85	20.83	23.85	29.71	--	Pass
157	5785	--	20.81	21.19	24.01	29.71	--	Pass
165	5825	--	20.83	21.03	23.94	29.71	--	Pass

Note:

1. Output Power (dBm) = 10LOG (Chain A Power (mW)+ Chain B Power (mW))
2. 26dB Bandwidth is the bandwidth of chain A or chain B whichever is less bandwidth, output power limitation is more stringent.

26dB Occupied Bandwidth:

Channel 52 (Chain A)

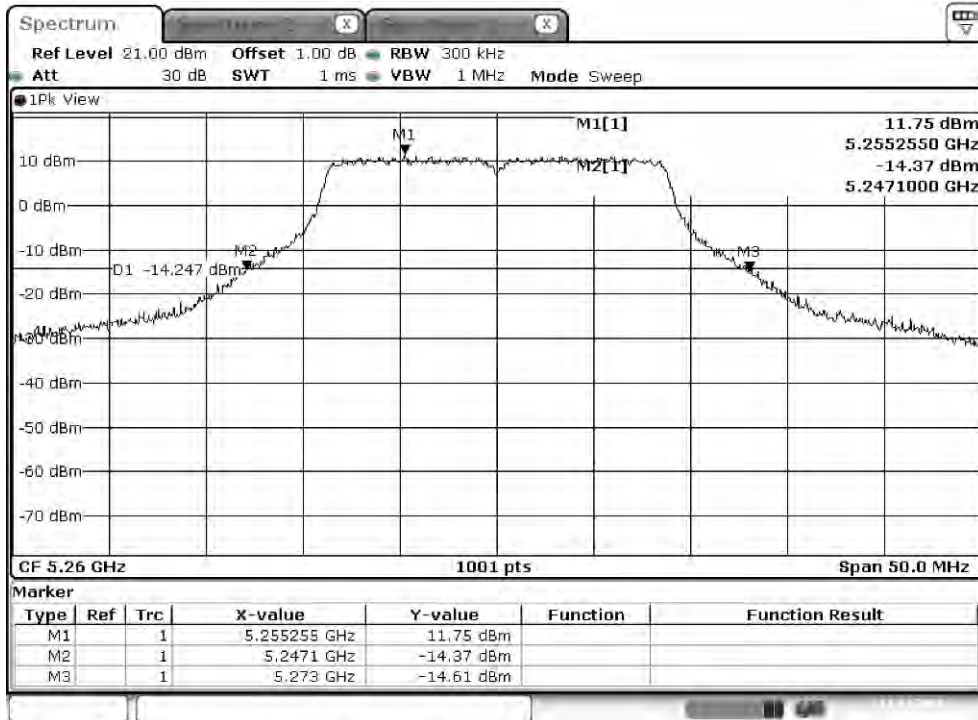

Channel 52 (Chain B)

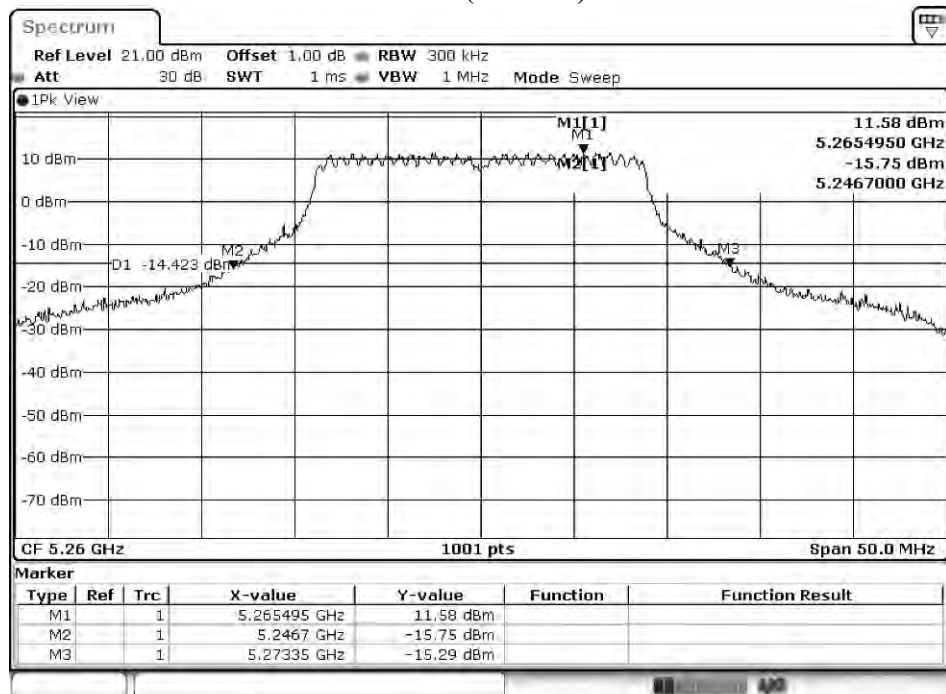

Date: 13.NOV.2019 21:11:33

Channel 60 (Chain A)

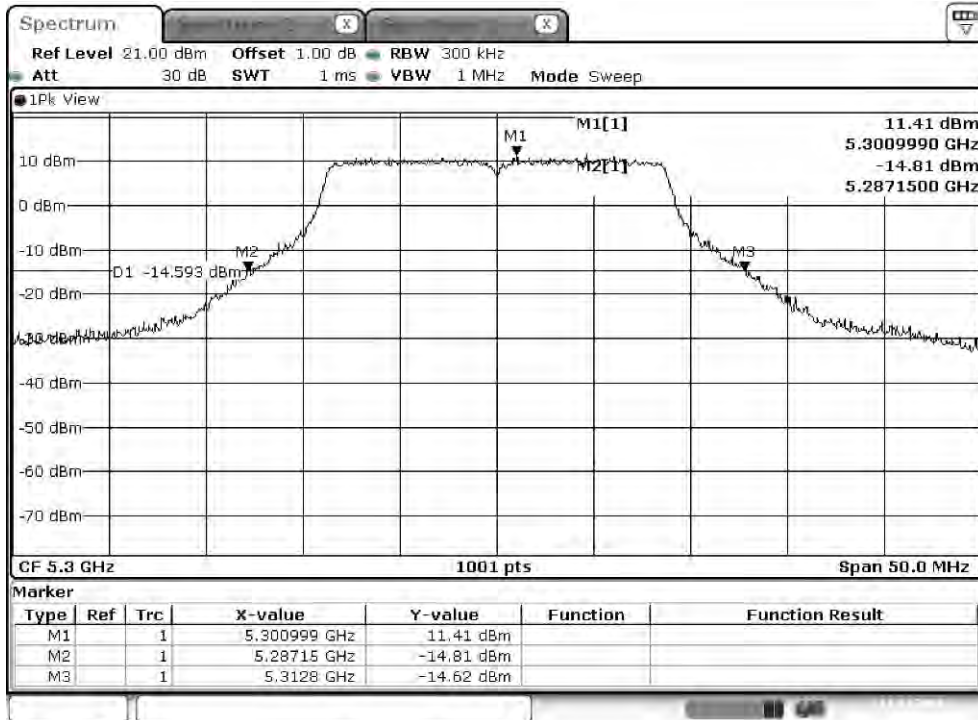

Channel 60 (Chain B)

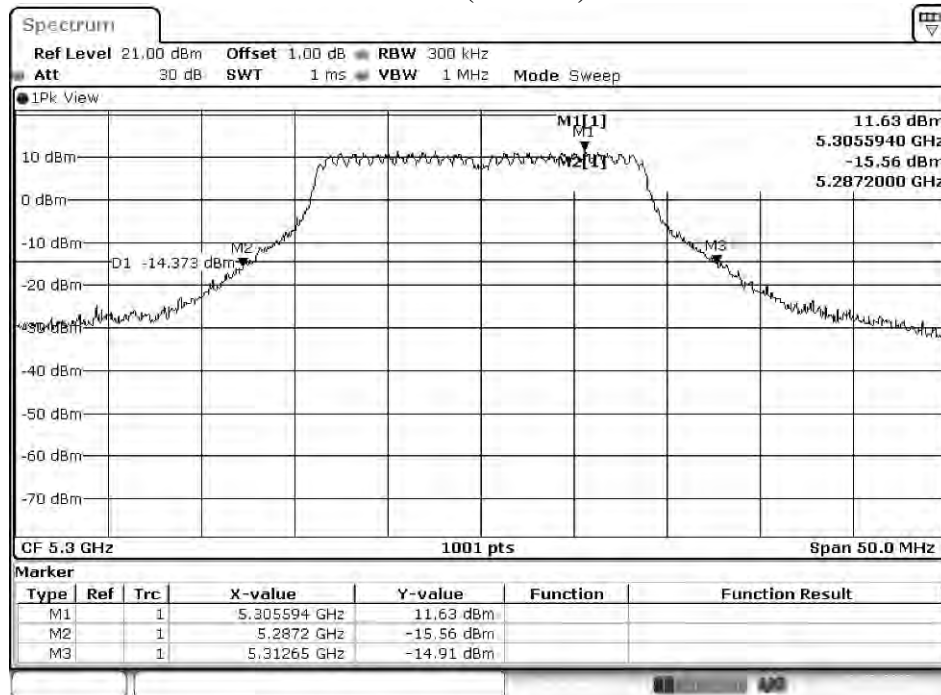

Date: 13.NOV.2019 21:13:05

Channel 64 (Chain A)

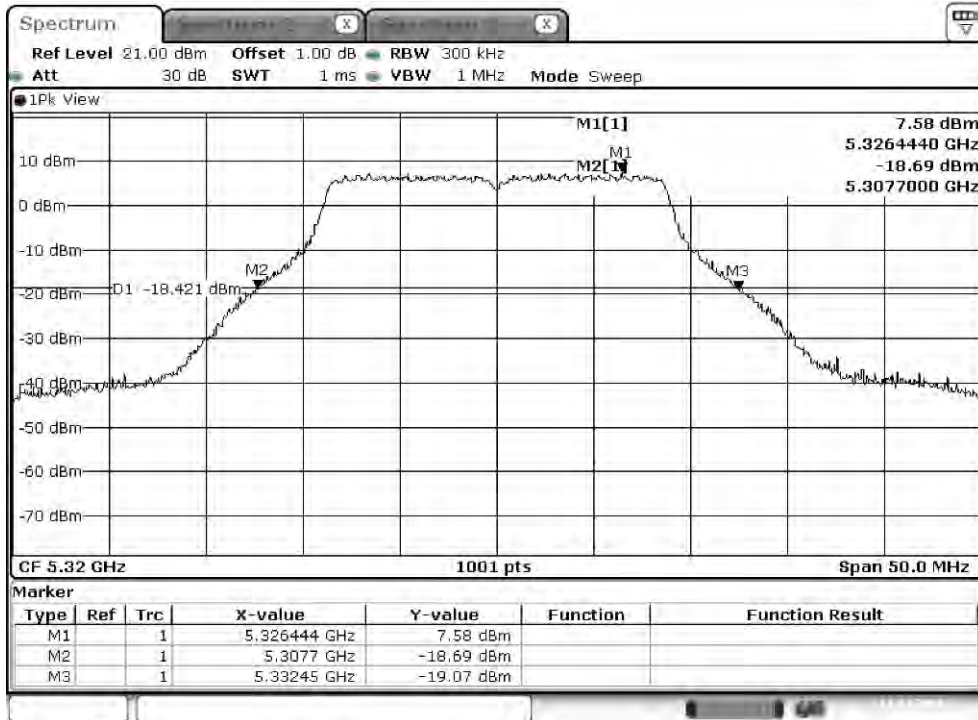

Channel 64 (Chain B)

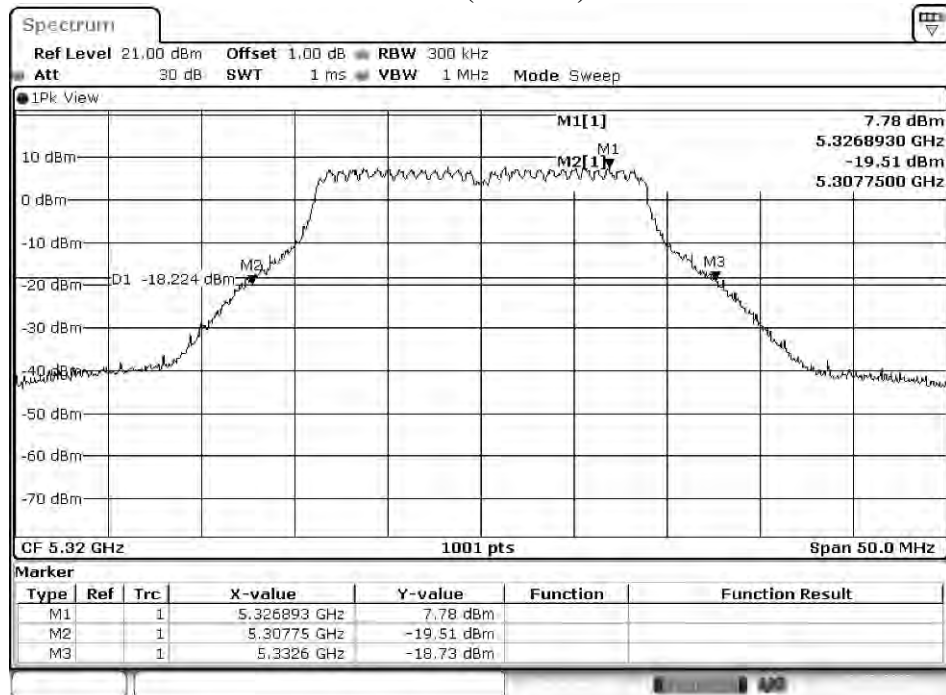

Date: 13.NOV.2019 21:15:38

Channel 100 (Chain A)

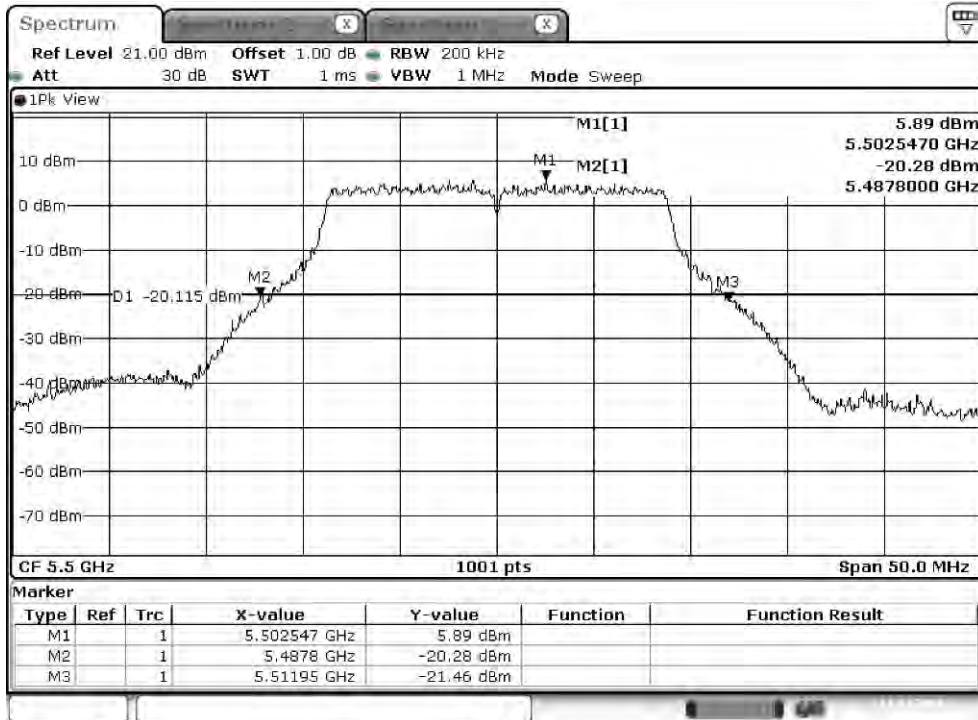

Channel 100 (Chain B)

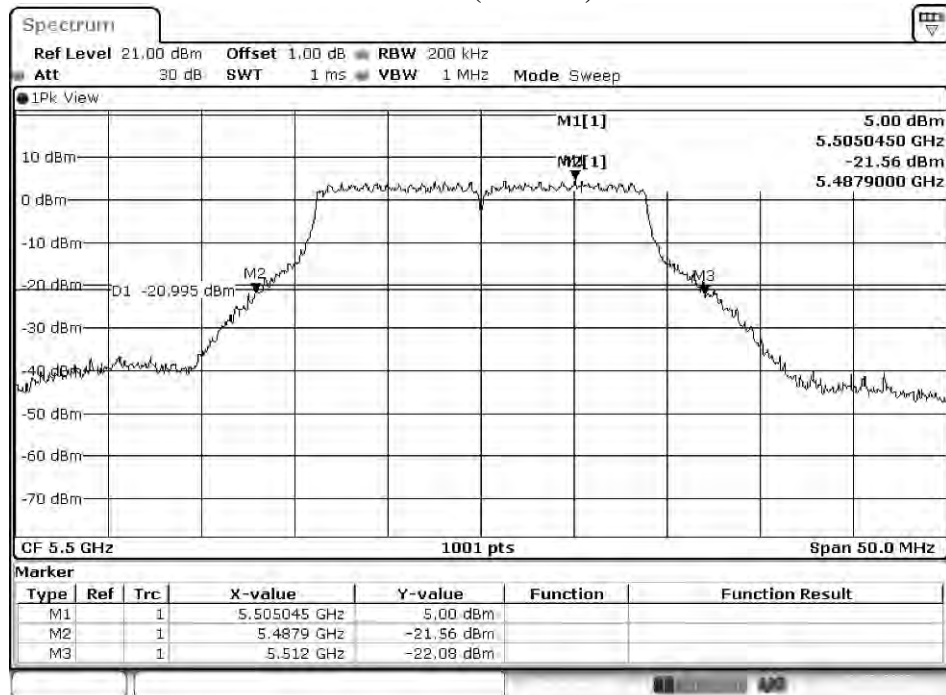

Date: 13.NOV.2019 21:17:53

Channel 116 (Chain A)

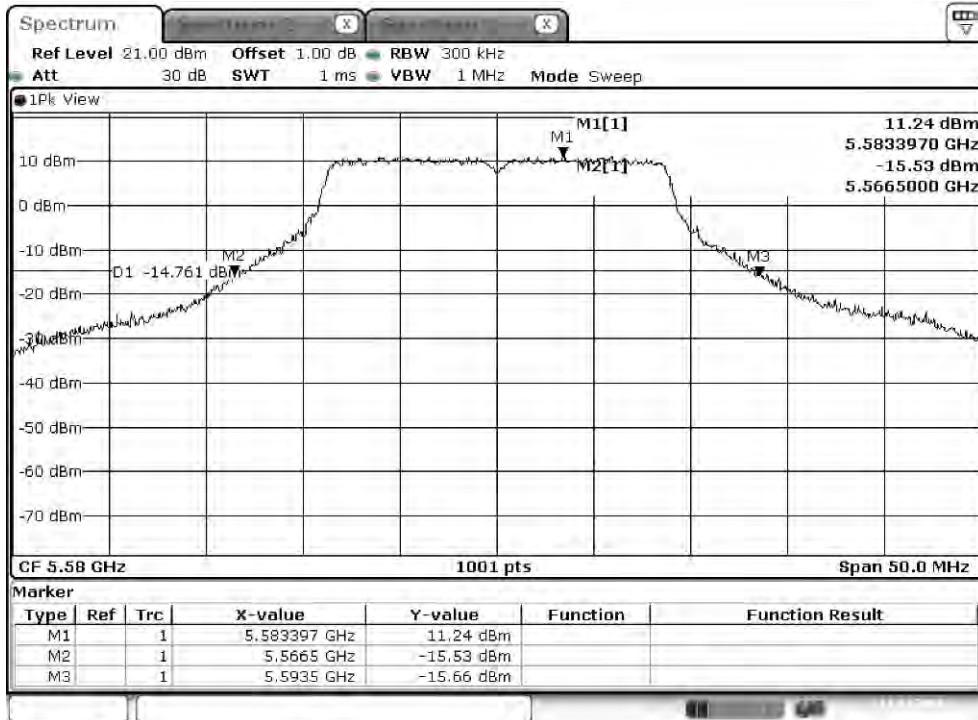

Channel 116 (Chain B)

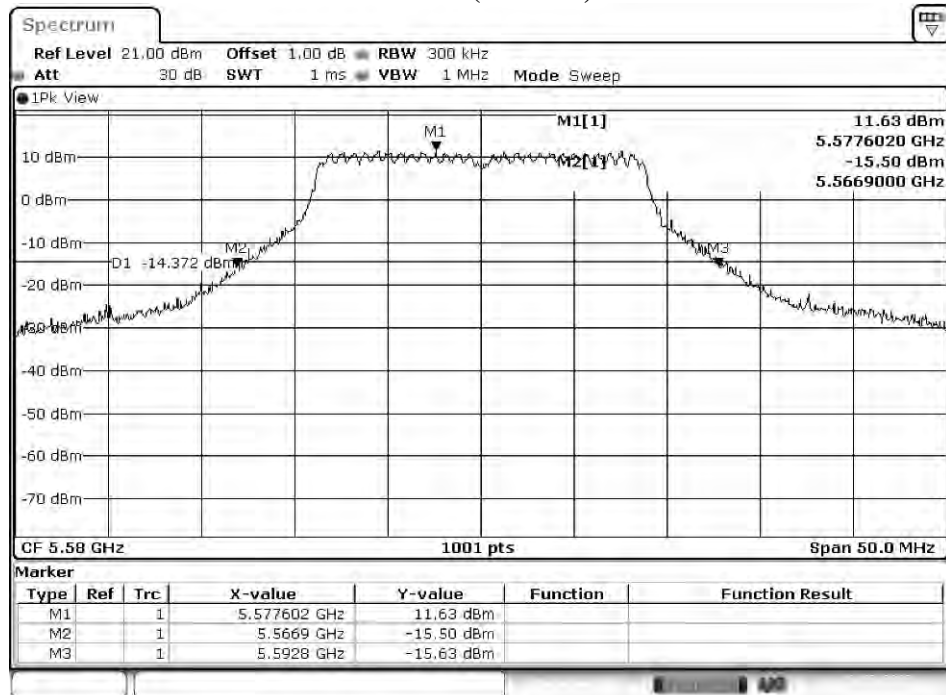

Date: 13.NOV.2019 21:19:35

Channel 140 (Chain A)

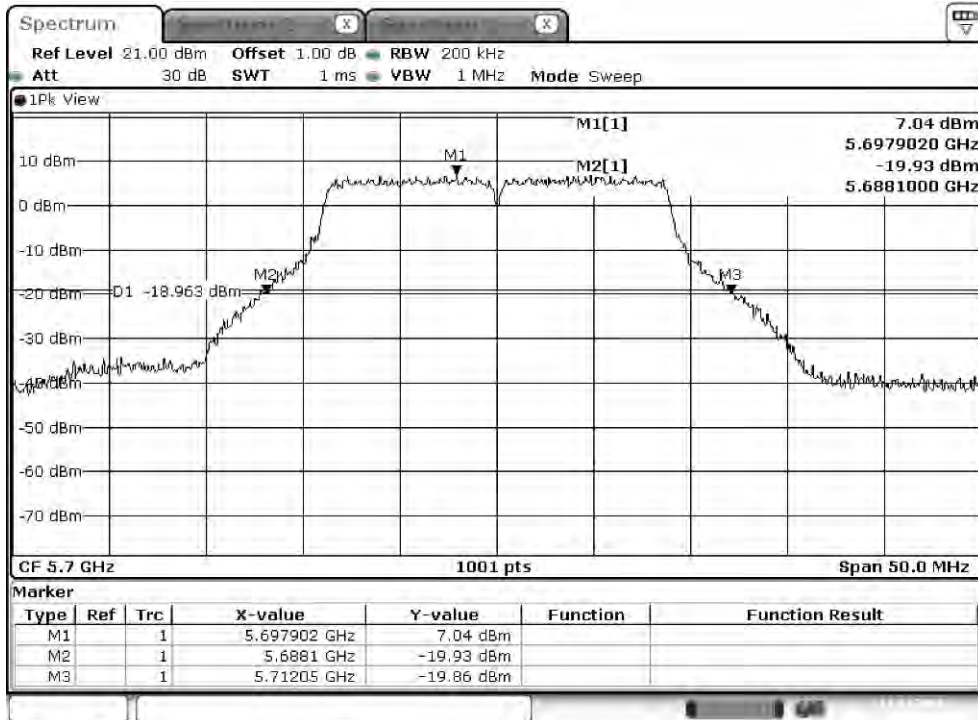

Channel 140 (Chain B)

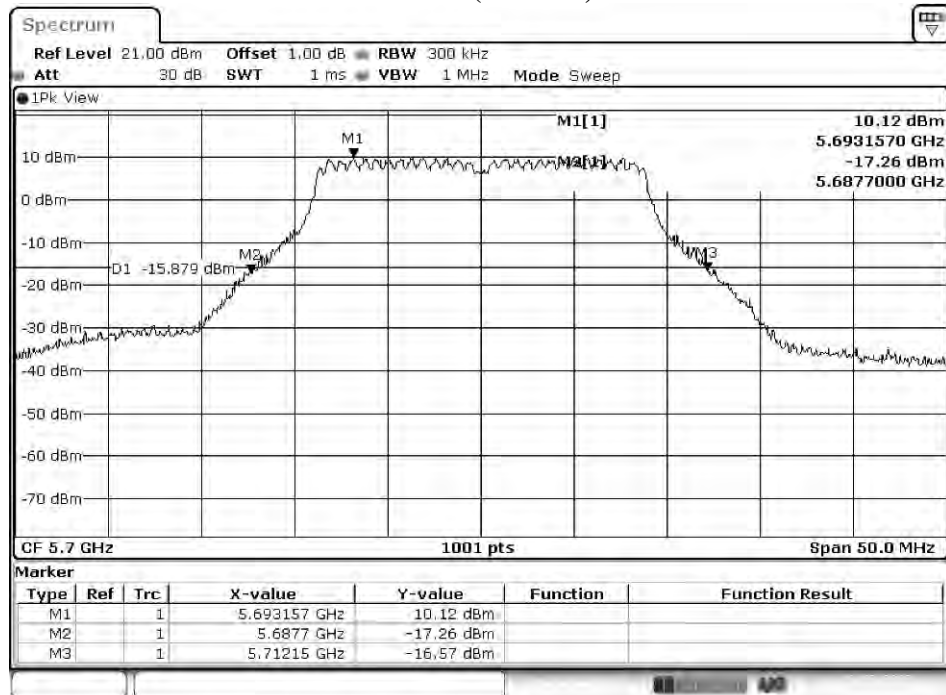

Date: 13.NOV.2019 21:22:49

Channel 144 (Chain A)

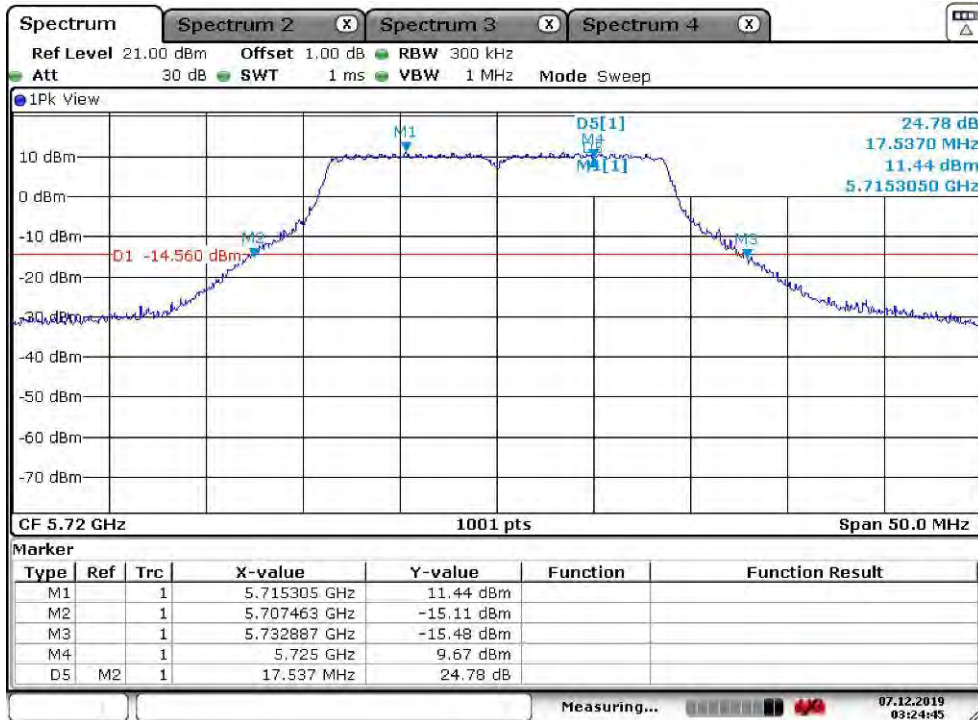

Channel 144 (Chain B)

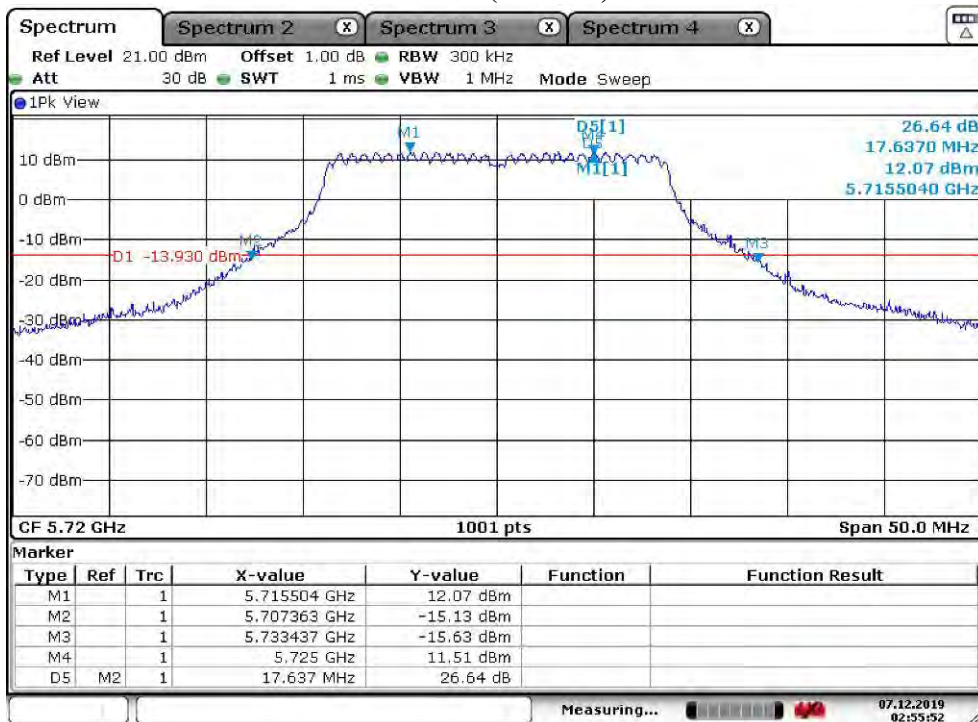

**Maximum conducted output power:
Channel 144 (U-NII-2C) (Chain A)**

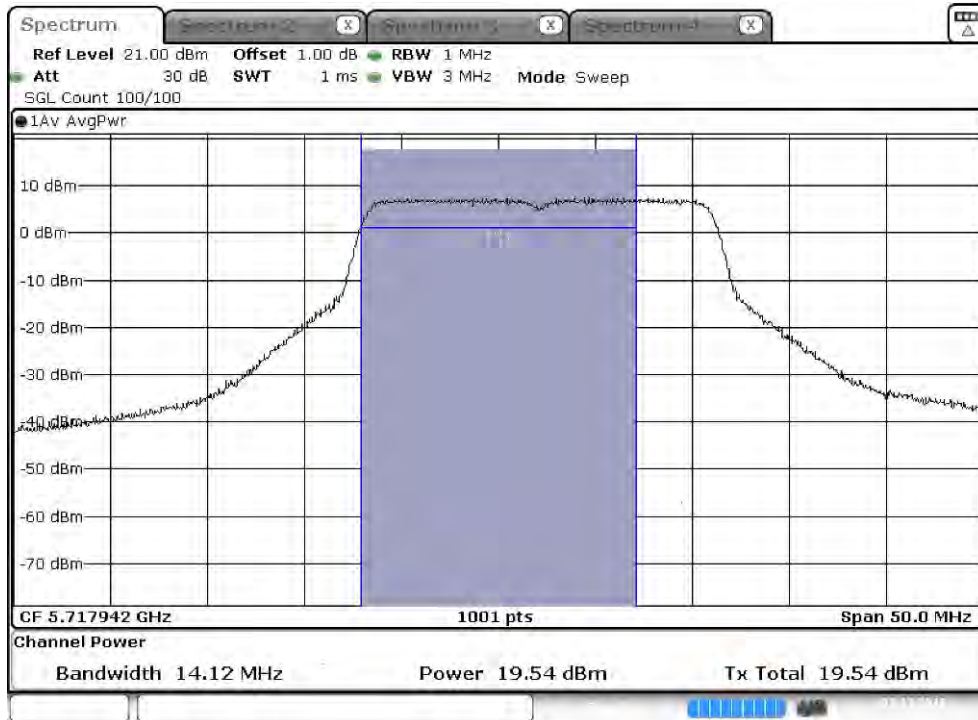

**Maximum conducted output power:
Channel 144 (U-NII-3) (Chain A)**



**Maximum conducted output power:
Channel 144 (U-NII-2C) (Chain B)**

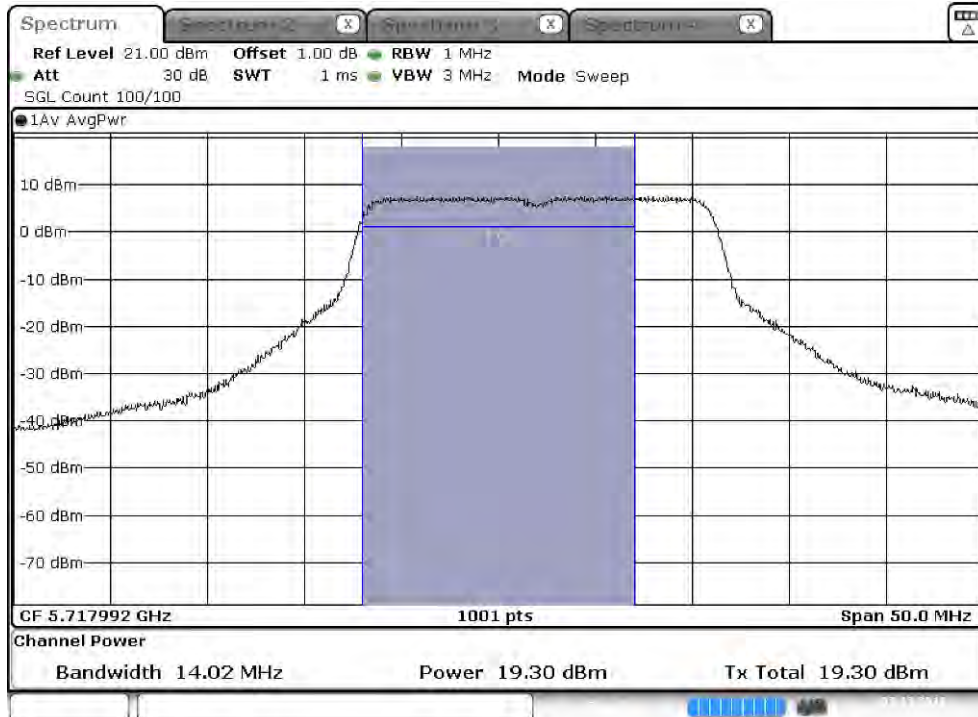

**Maximum conducted output power:
Channel 144 (U-NII-3) (Chain B)**

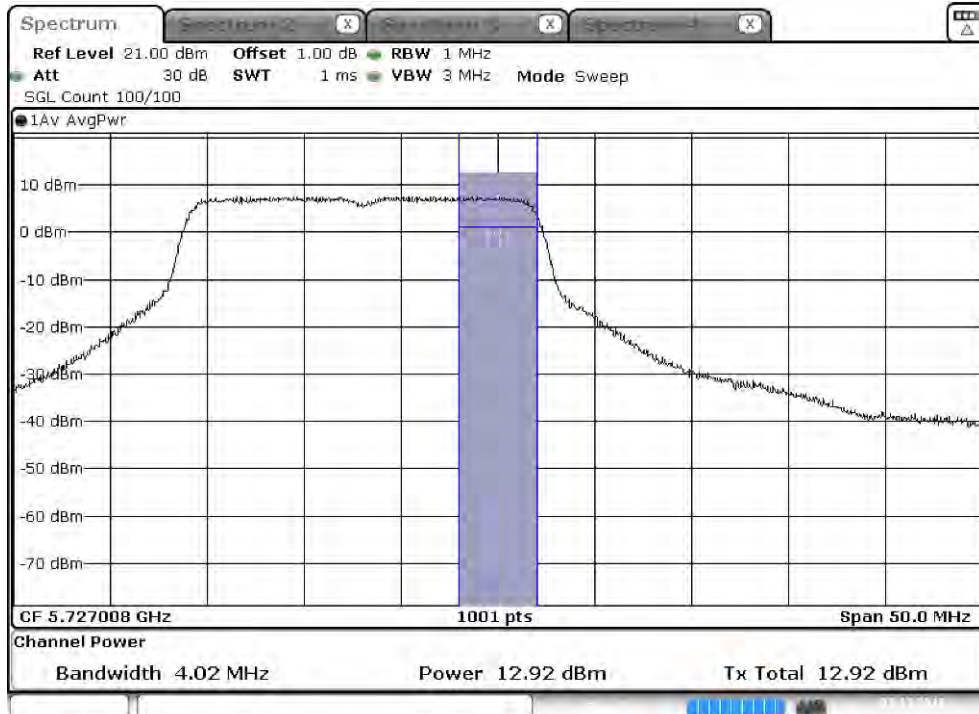

Product : Intel® Wireless-AC 9560
 Test Item : Maximum conducted output power
 Test Date : 2019/12/03
 Test Mode : Mode 12 MIMO: Transmit (802.11n-40BW_30Mbps)

Chain A

Cable loss=1.0dB		Maximum conducted output power							
Channel No.	Frequency (MHz)	Data Rate (Mbps)							
		30	60	90	120	180	240	270	300
38	5190	15.71	--	--	--	--	--	--	--
46	5230	18.63	18.59	18.52	18.49	18.44	18.39	18.35	18.30
54	5270	17.82	--	--	--	--	--	--	--
62	5310	14.54	14.50	14.47	14.40	14.37	14.33	14.26	14.19
102	5510	13.81	--	--	--	--	--	--	--
110	5550	20.74	20.71	20.66	20.62	20.58	20.55	20.51	20.44
134	5670	15.83	--	--	--	--	--	--	--
142(U-NII-2C)	5710	19.67	19.62	19.58	19.51	19.47	19.42	19.38	19.33
142(U-NII-3)	5710	9.74	9.69	9.65	9.60	9.53	9.50	9.43	9.39
151	5755	18.98	--	--	--	--	--	--	--
159	5795	19.97	19.92	19.89	19.85	19.78	19.71	19.66	19.63

Note: Maximum conducted output power Value =Reading value on average power meter + cable loss

Chain B

Cable loss=1.0dB		Maximum conducted output power							
Channel No.	Frequency (MHz)	Data Rate (Mbps)							
		30	60	90	120	180	240	270	300
38	5190	15.48	--	--	--	--	--	--	--
46	5230	18.58	18.52	18.45	18.40	18.36	18.32	18.27	18.23
54	5270	17.68	--	--	--	--	--	--	--
62	5310	14.51	14.48	14.43	14.37	14.31	14.25	14.21	14.15
102	5510	13.54	--	--	--	--	--	--	--
110	5550	19.36	19.31	19.25	19.21	19.16	19.10	19.03	18.98
134	5670	16.75	--	--	--	--	--	--	--
142(U-NII-2C)	5710	19.96	19.92	19.85	19.82	19.76	19.73	19.69	19.63
142(U-NII-3)	5710	10.07	10.03	9.97	9.91	9.87	9.80	9.74	9.68
151	5755	18.21	--	--	--	--	--	--	--
159	5795	19.42	19.36	19.31	19.24	19.17	19.13	19.07	19.01

Note: Maximum conducted output power Value =Reading value on average power meter + cable loss

Maximum conducted output power Measurement:

Channel No	Frequency Range (MHz)	26dB Bandwidth (MHz)	Chain A Power (dBm)	Chain B Power (dBm)	Output Power (dBm)	Output Power Limit		Result
						(dBm)	dBm+10log(BW)	
38	5190	--	15.71	15.48	18.61	23.36	--	Pass
46	5230	--	18.63	18.58	21.62	23.36	--	Pass
54	5270	42.700	17.82	17.68	20.76	23.63	26.93	Pass
62	5310	43.700	14.54	14.51	17.54	23.63	27.03	Pass
102	5510	44.100	13.81	13.54	16.69	23.13	26.57	Pass
110	5550	44.600	20.74	19.36	23.11	23.13	26.62	Pass
134	5670	44.500	15.83	16.75	19.32	23.13	26.61	Pass
142(U-NII-2C)	5710	39.680	19.67	19.96	22.83	23.13	26.12	Pass
142(U-NII-3)	5710	--	9.74	10.07	12.92	29.71	--	Pass
151	5755	--	18.98	18.21	21.62	29.71	--	Pass
159	5795	--	19.97	19.42	22.71	29.71	--	Pass

Note:

1. Output Power (dBm) = 10LOG (Chain A Power (mW)+ Chain B Power (mW))
2. 26dB Bandwidth is the bandwidth of chain A or chain B whichever is less bandwidth, output power limitation is more stringent.

26dB Occupied Bandwidth:

Channel 54 (Chain A)

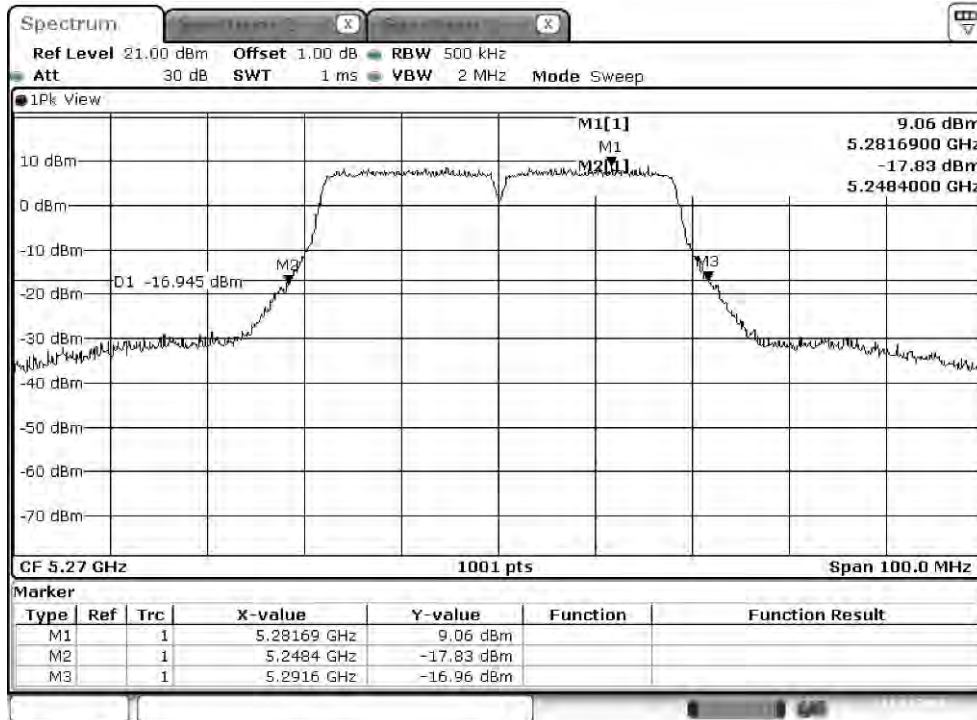

Channel 54 (Chain B)

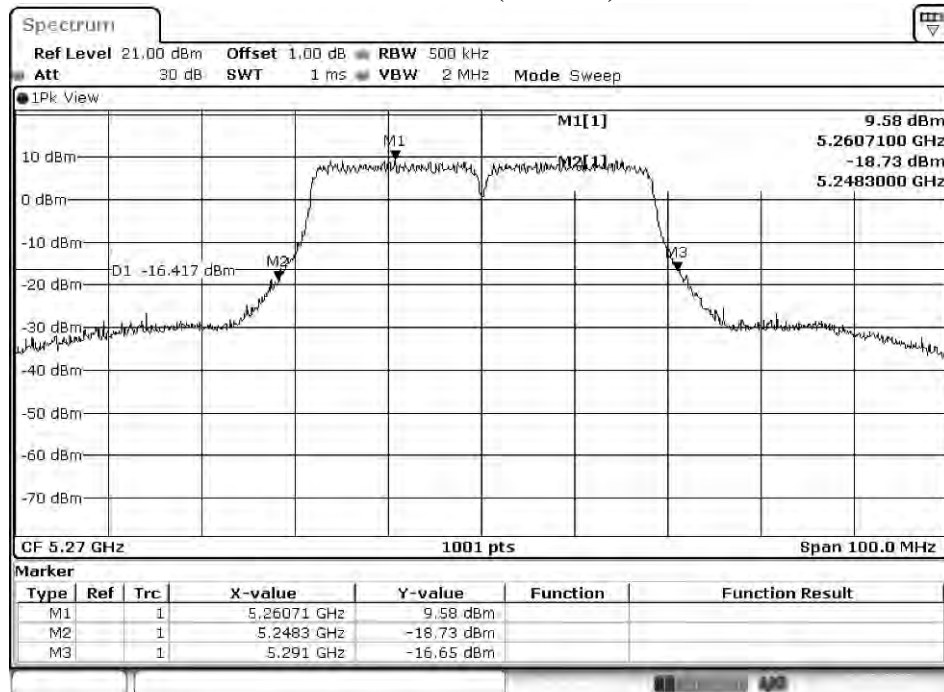

Date: 13.NOV.2019 21:27:29

Channel 62 (Chain A)

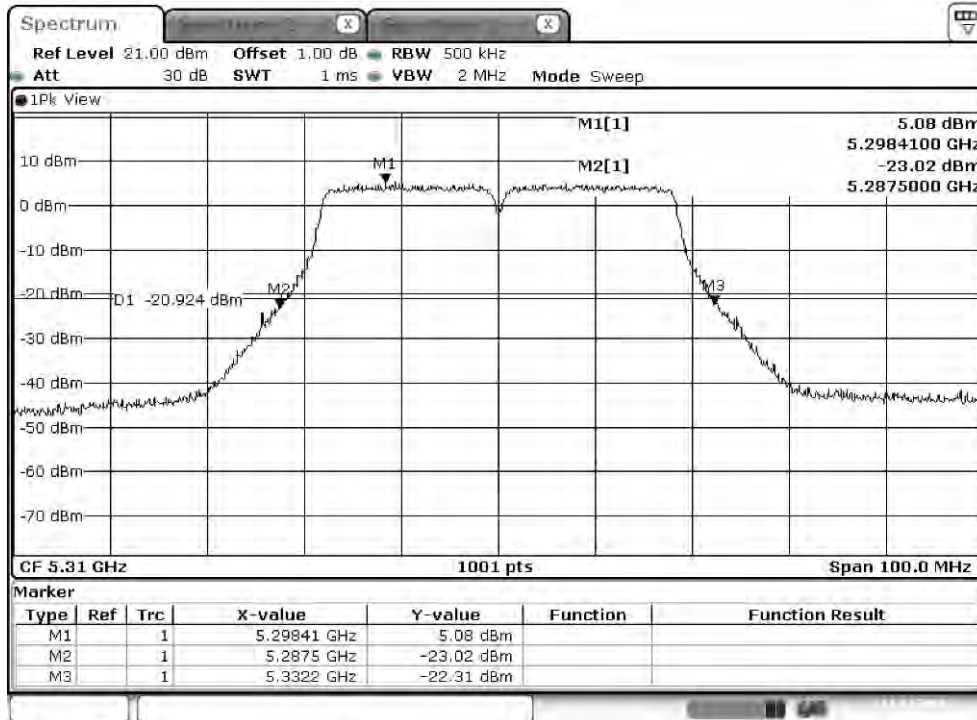

Channel 62 (Chain B)

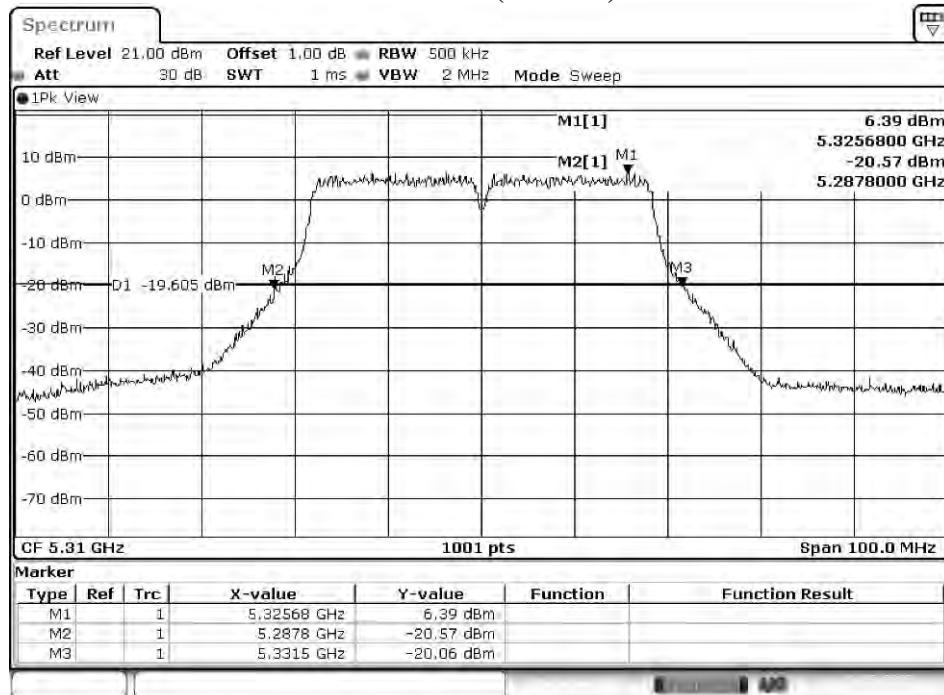

Date: 13.NOV.2019 21:29:15

Channel 102 (Chain A)

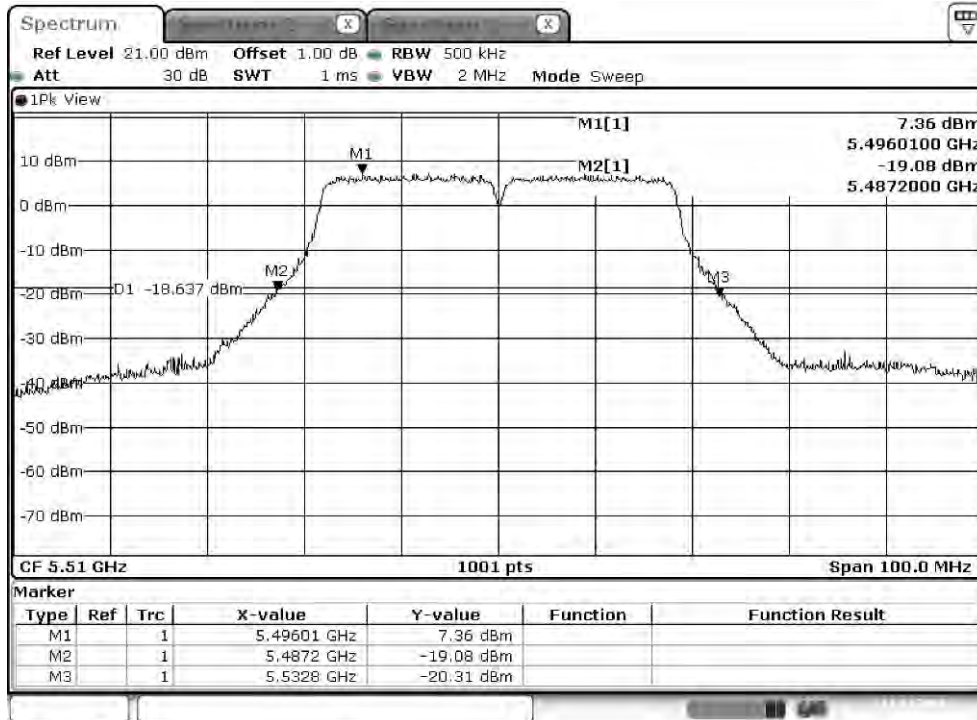

Channel 102 (Chain B)

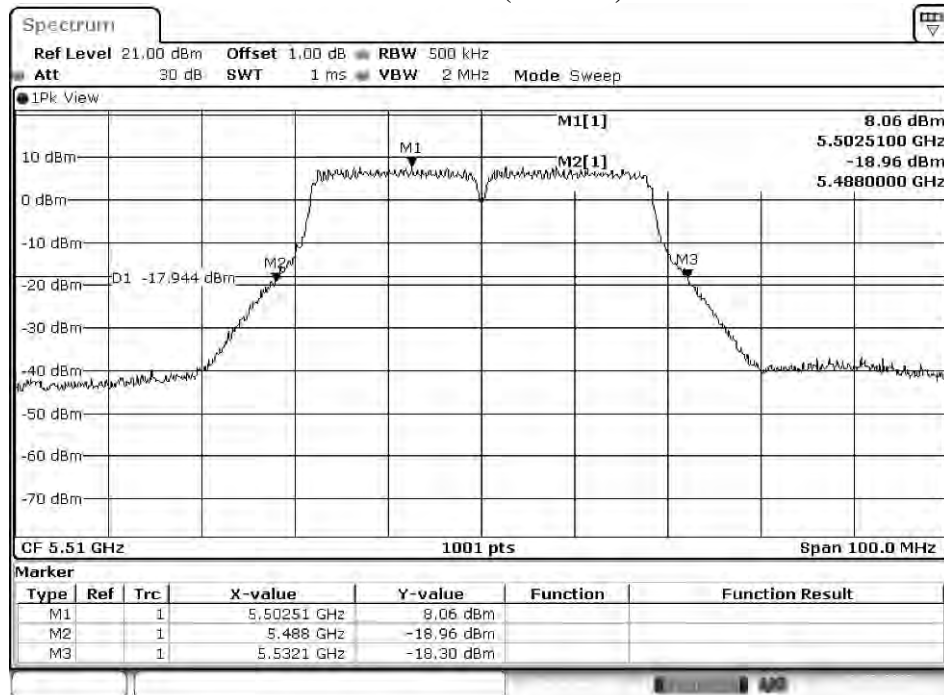

Date: 13.NOV.2019 21:32:09

Channel 110 (Chain A)

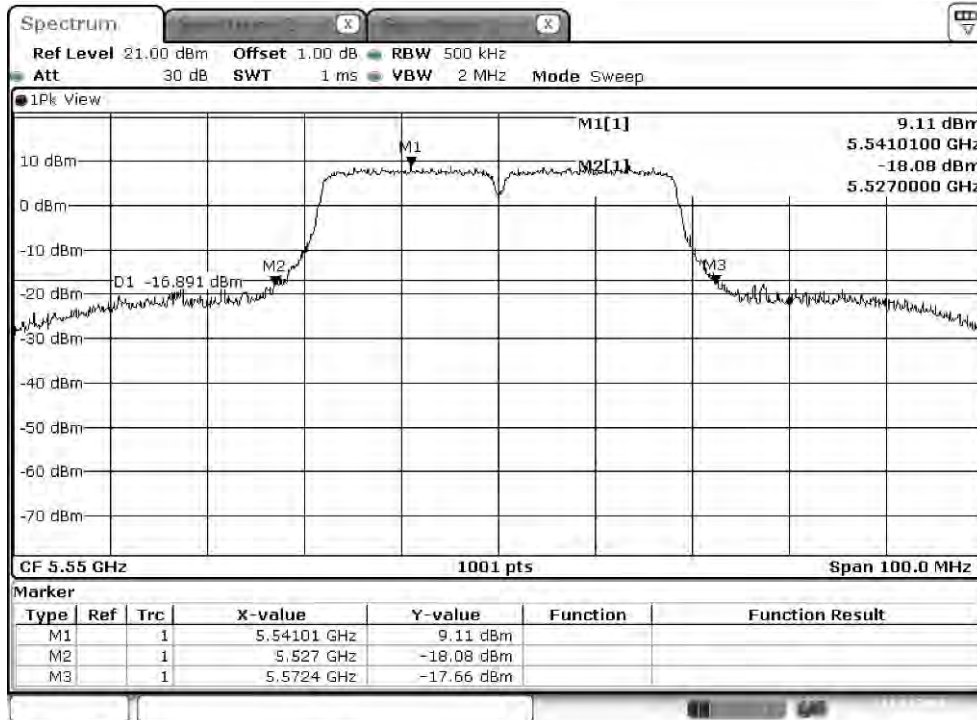

Channel 110 (Chain B)

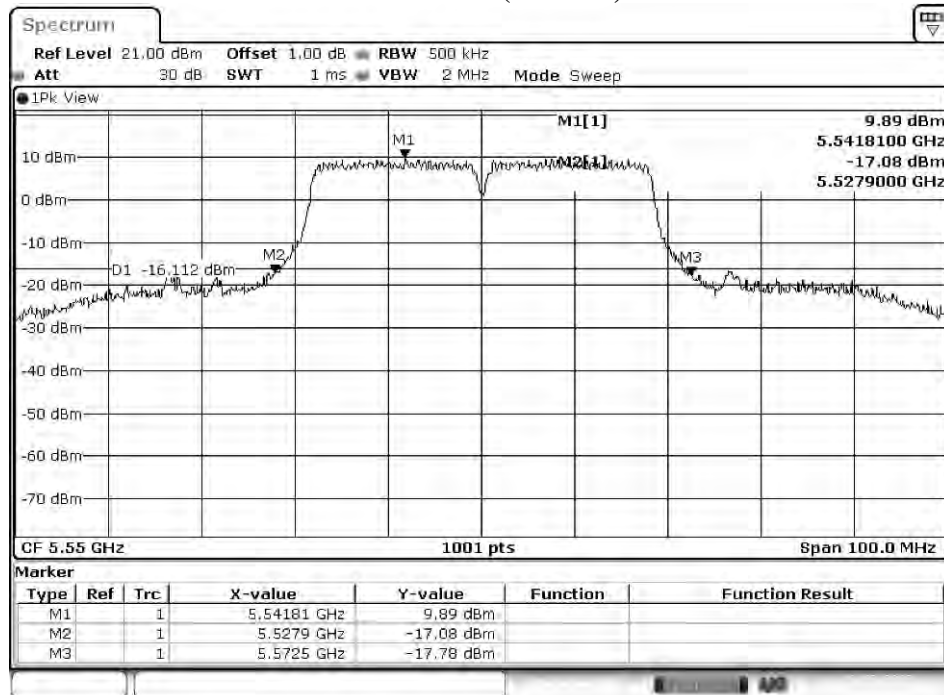

Date: 13.NOV.2019 21:33:48

Channel 134 (Chain A)

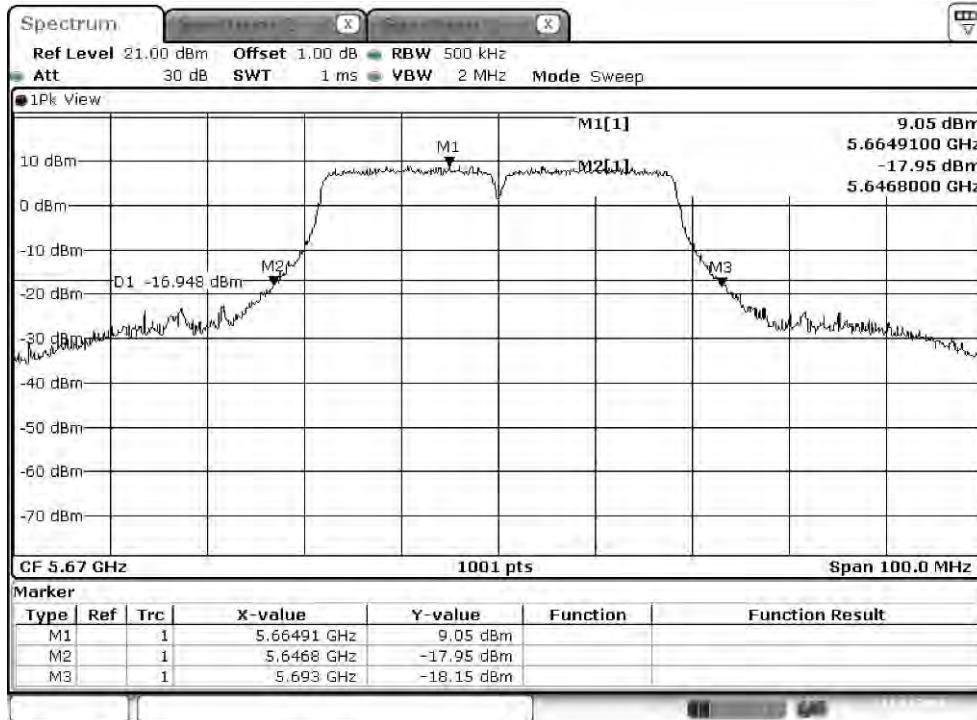

Channel 134 (Chain B)

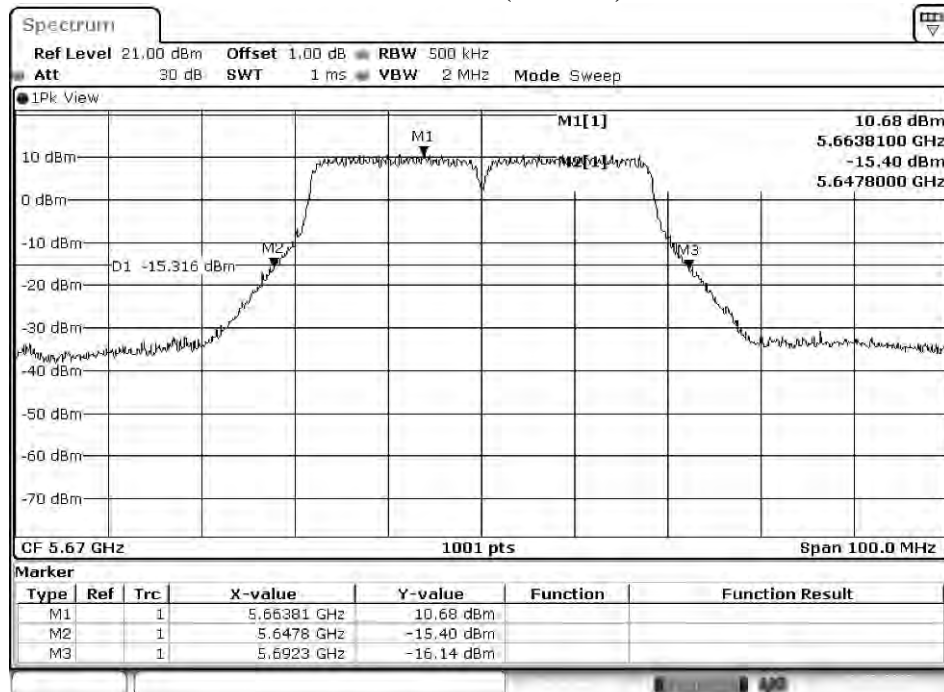

Date: 13.NOV.2019 21:37:35

Channel 142 (Chain A)

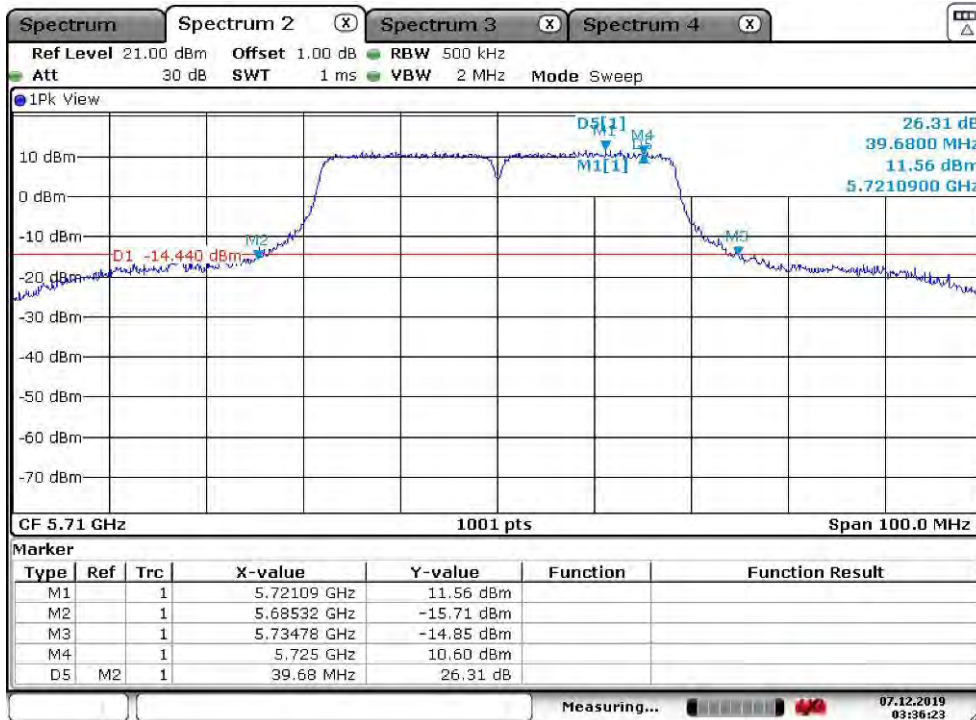

Channel 142 (Chain B)

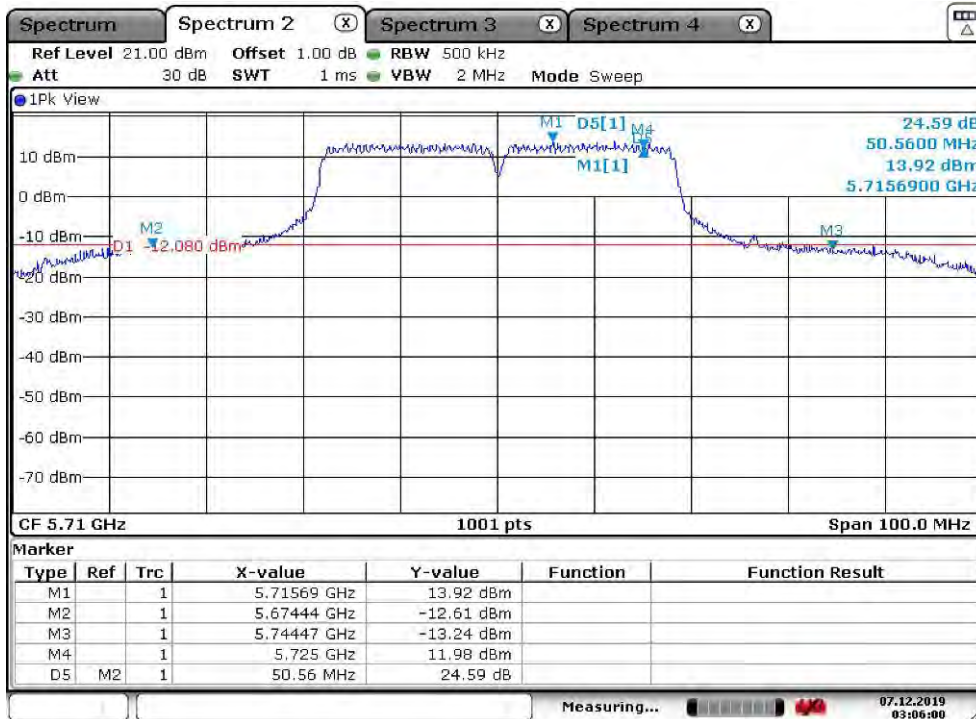

**Maximum conducted output power:
Channel 142 (U-NII-2C) (Chain A)**

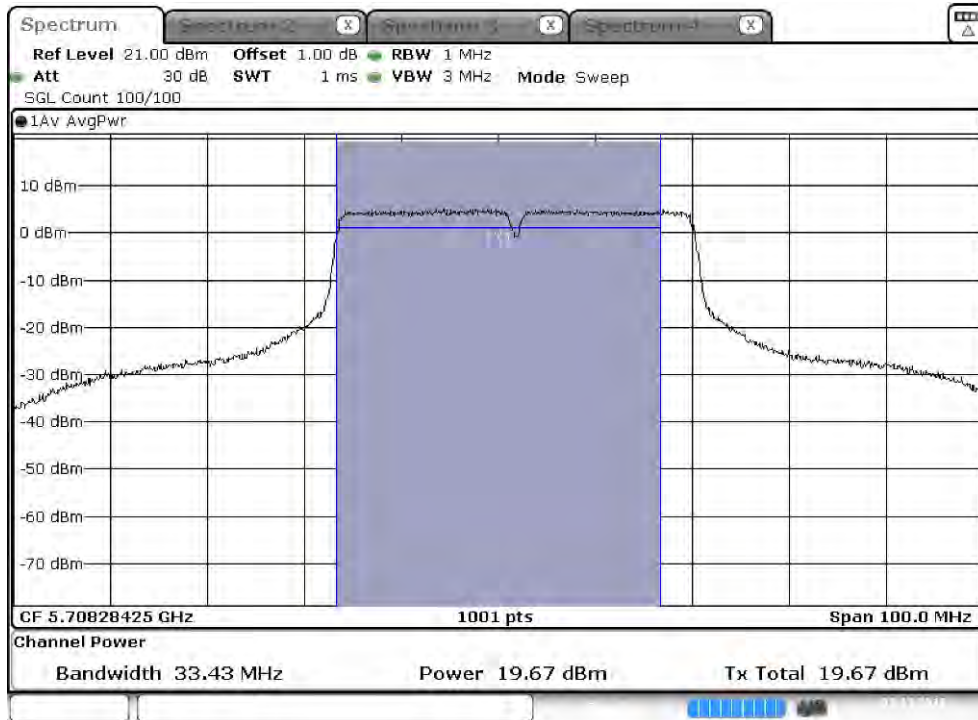

**Maximum conducted output power:
Channel 142 (U-NII-3) (Chain A)**

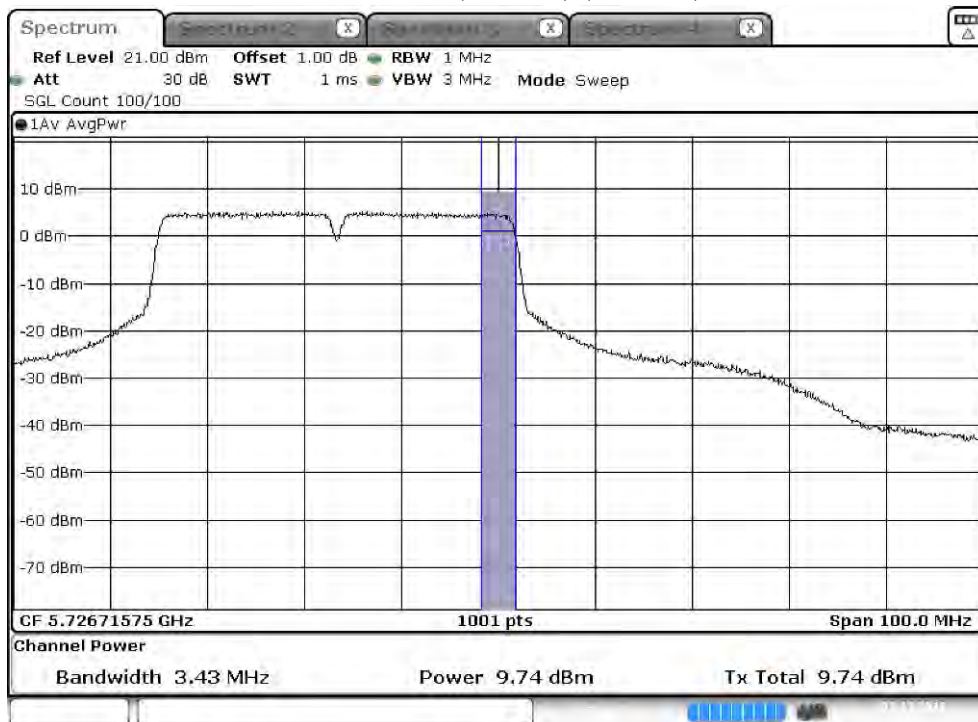

**Maximum conducted output power:
Channel 142 (U-NII-2C) (Chain B)**

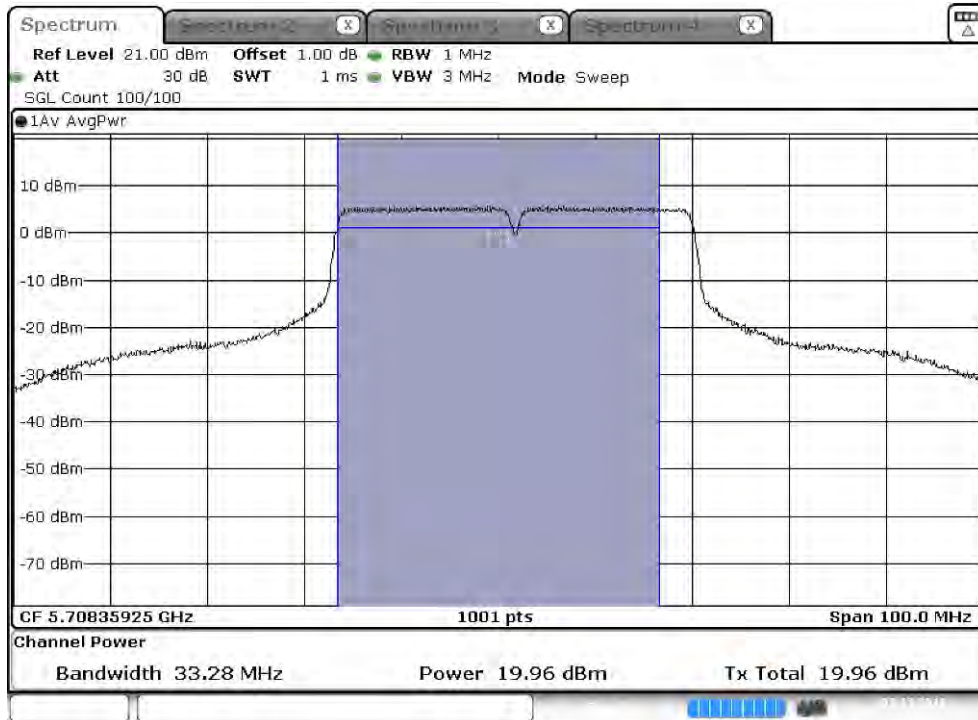

**Maximum conducted output power:
Channel 142 (U-NII-3) (Chain B)**

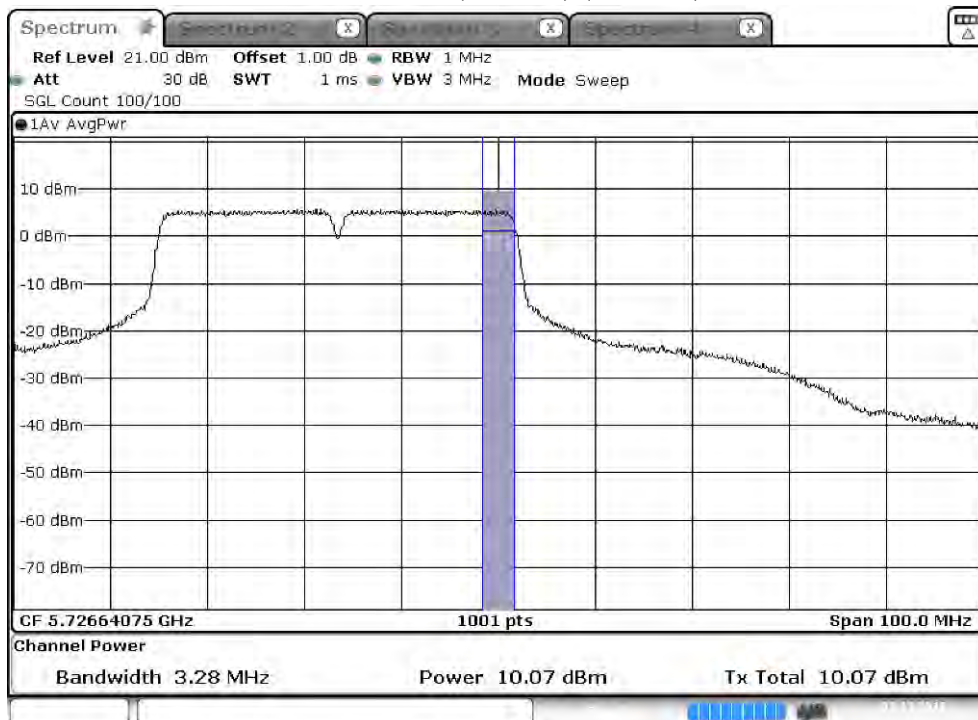

Product : Intel® Wireless-AC 9560
 Test Item : Maximum conducted output power
 Test Date : 2019/12/03
 Test Mode : Mode 13 MIMO: Transmit (802.11ac-80BW_65Mbps)

Chain A

Cable loss=1.0dB		Maximum conducted output power									
Channel No	Frequency (MHz)	Data Rate (Mbps)									
		65	130	1965	260	390	520	585	650	780	866.7
42	5210	15.53	15.48	15.41	15.38	15.31	15.27	15.23	15.18	15.13	15.08
58	5290	13.07	13.00	12.96	12.90	12.85	12.79	12.72	12.66	12.60	12.53
106	5530	15.39	--	--	--	--	--	--	--	--	--
122	5610	19.63	19.59	19.55	19.51	19.46	19.39	19.35	19.29	19.22	19.17
138 (U-NII-2C)	5690	19.72	--	--	--	--	--	--	--	--	--
138 (U-NII-3)	5690	2.85	--	--	--	--	--	--	--	--	--
155	5775	17.61	17.56	17.50	17.43	17.36	17.29	17.24	17.19	17.15	17.10

Note: Maximum conducted output power Value =Reading value on Spectrum Analyzer + cable loss

Chain B

Cable loss=1.0dB		Maximum conducted output power									
Channel No	Frequency (MHz)	Data Rate (Mbps)									
		65	130	1965	260	390	520	585	650	780	866.7
42	5210	13.60	13.54	13.47	13.42	13.37	13.31	13.28	13.24	13.19	13.12
58	5290	12.61	12.56	12.50	12.46	12.41	12.36	12.31	12.25	12.20	12.14
106	5530	15.42	--	--	--	--	--	--	--	--	--
122	5610	20.44	20.38	20.33	20.27	20.23	20.19	20.12	20.09	20.04	19.97
138 (U-NII-2C)	5690	20.26	--	--	--	--	--	--	--	--	--
138 (U-NII-3)	5690	3.35	--	--	--	--	--	--	--	--	--
155	5775	17.43	17.37	17.31	17.24	17.21	17.16	17.10	17.03	16.98	16.92

Note: Maximum conducted output power Value =Reading value on Spectrum Analyzer + cable loss

Maximum conducted output power Measurement:

Channel No	Frequency Range (MHz)	26dB Bandwidth (MHz)	Chain A Power (dBm)	Chain B Power (dBm)	Output Power (dBm)	Output Power Limit		Result
						(dBm)	dBm+10log(BW)	
42	5210	--	15.53	13.60	17.68	23.36	--	Pass
58	5290	86.600	13.07	12.61	15.86	23.63	30.01	Pass
106	5530	85.600	15.39	15.42	18.42	23.13	29.45	Pass
122	5610	86.600	19.63	20.44	23.06	23.13	29.51	Pass
138 (U-NII-2C)	5690	96.340	19.72	20.26	23.01	23.13	29.97	Pass
138 (U-NII-3)	5690	--	2.85	3.35	6.12	29.71	--	Pass
155	5775	--	17.61	17.43	20.53	29.71	--	Pass

Note:

1. Output Power (dBm) = 10LOG (Chain A Power (mW)+ Chain B Power (mW))
2. 26dB Bandwidth is the bandwidth of chain A or chain B whichever is less bandwidth, output power limitation is more stringent.

26dB Occupied Bandwidth:

Channel 58 (Chain A)

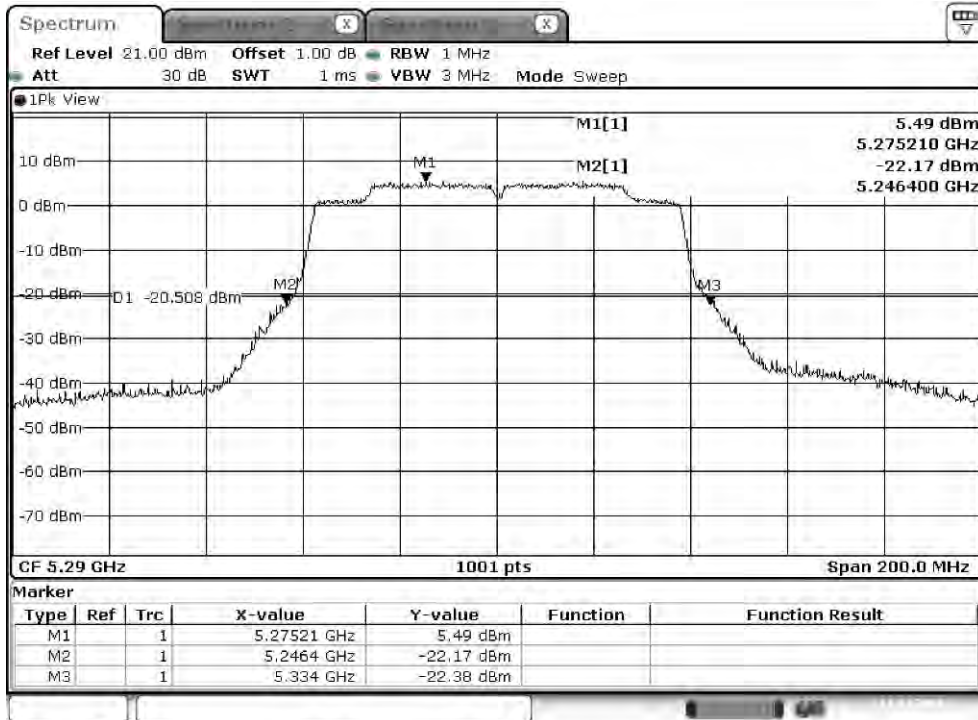

Channel 58 (Chain B)

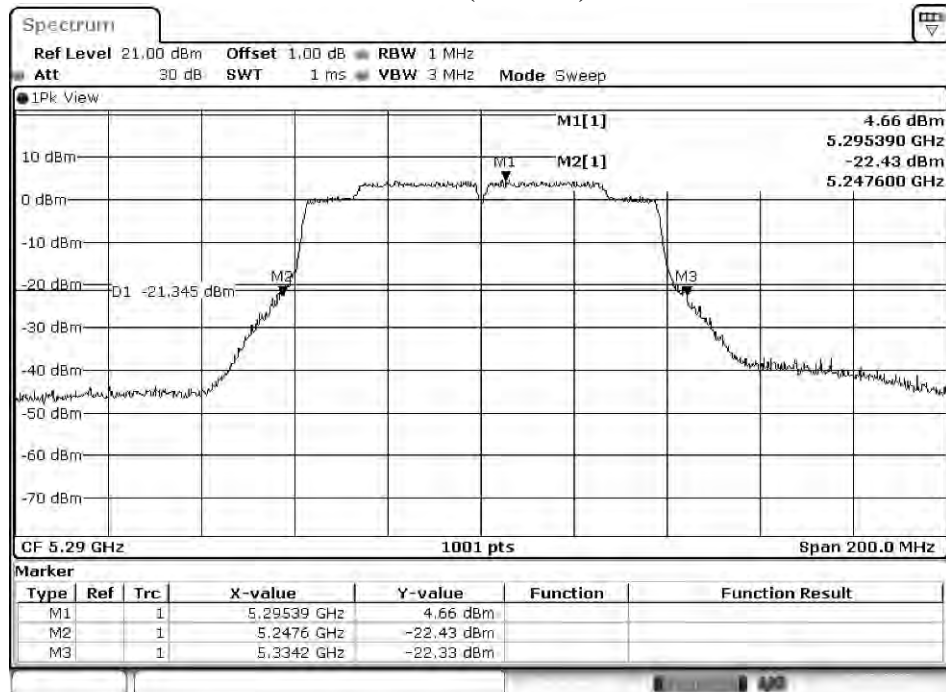

Date: 13.NOV.2019 20:54:24

Channel 106 (Chain A)

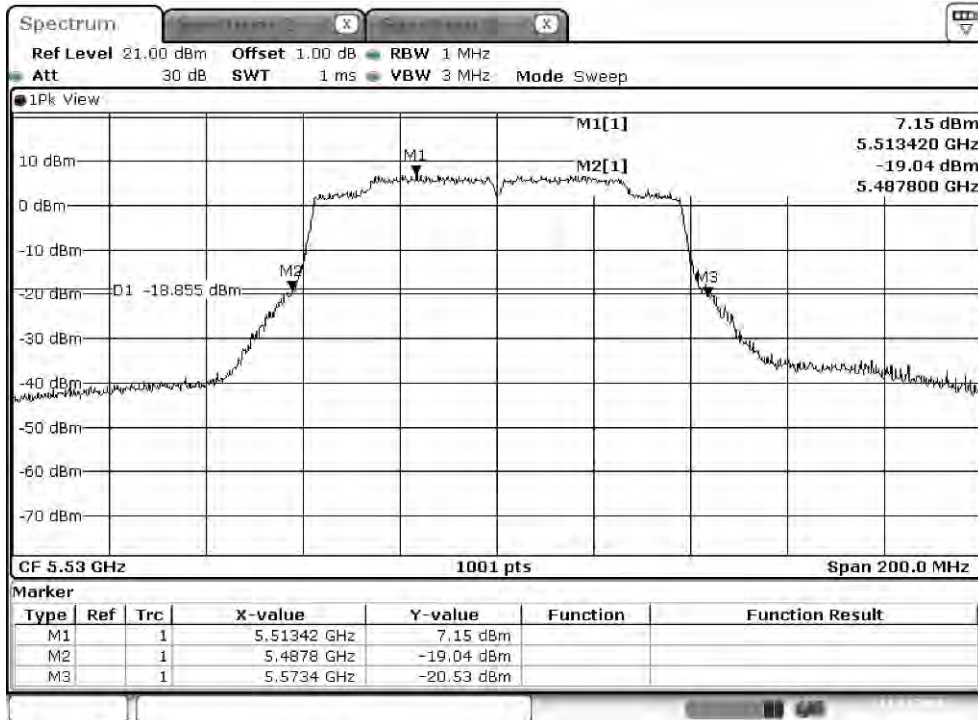

Channel 106 (Chain B)

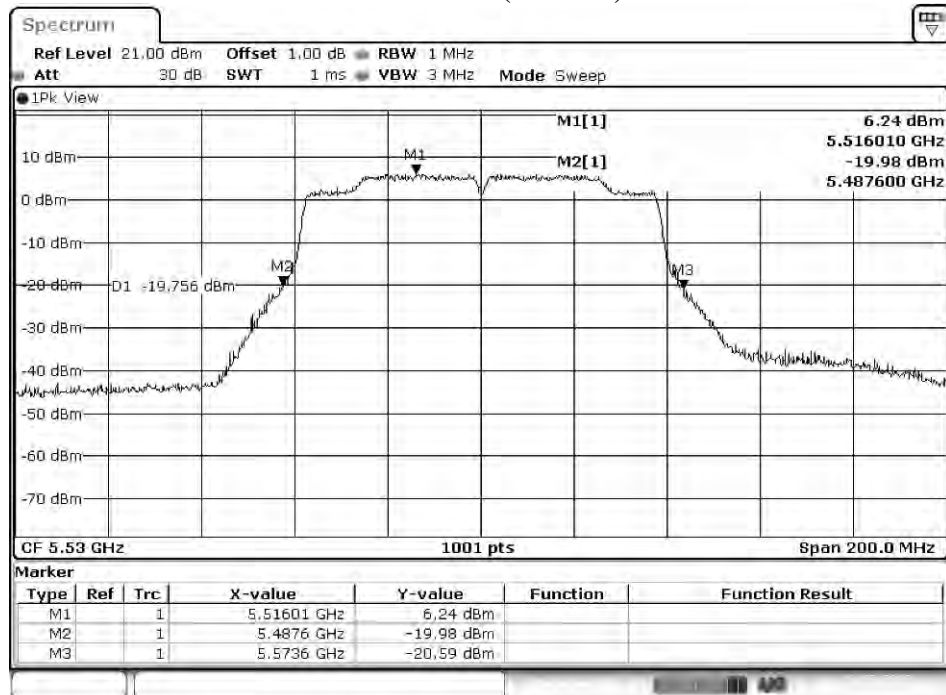

Date: 13.NOV.2019 20:56:44

Channel 122 (Chain A)

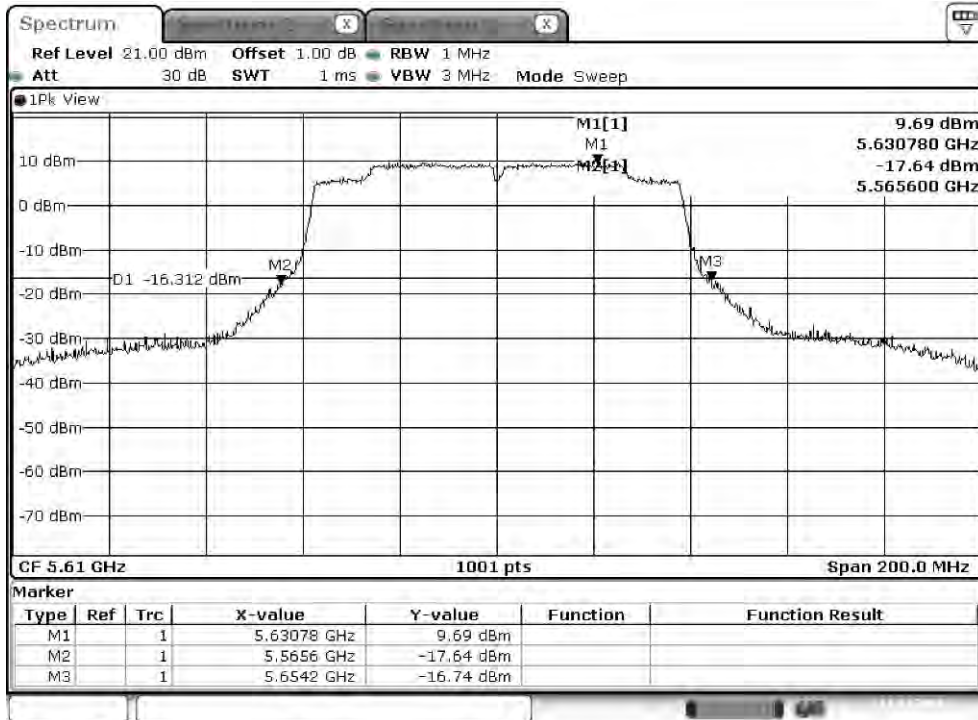

Channel 122 (Chain B)

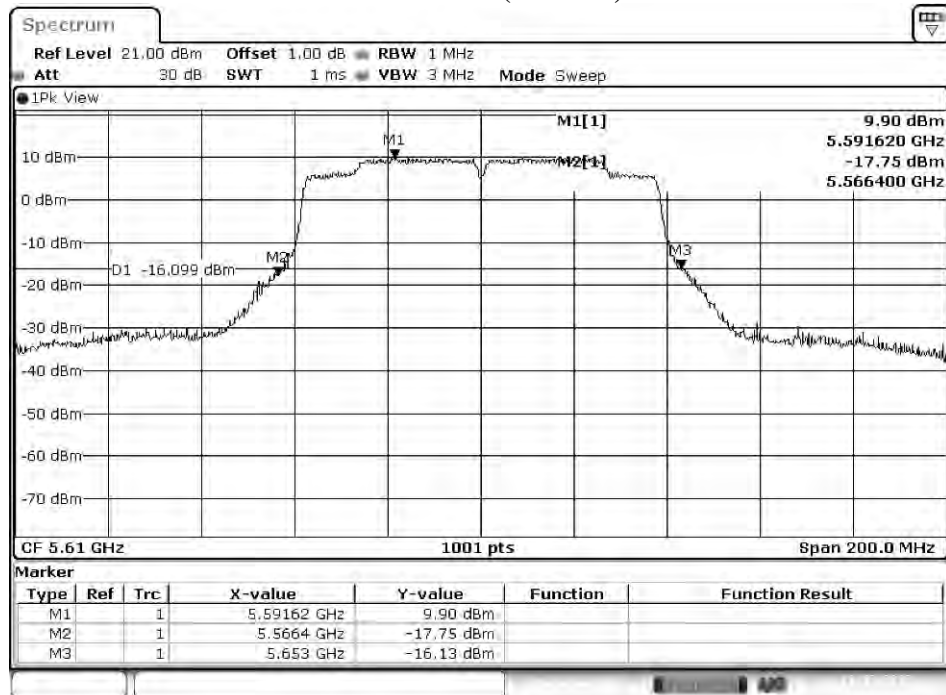

Date: 13.NOV.2019 20:59:09

Channel 138 (Chain A)

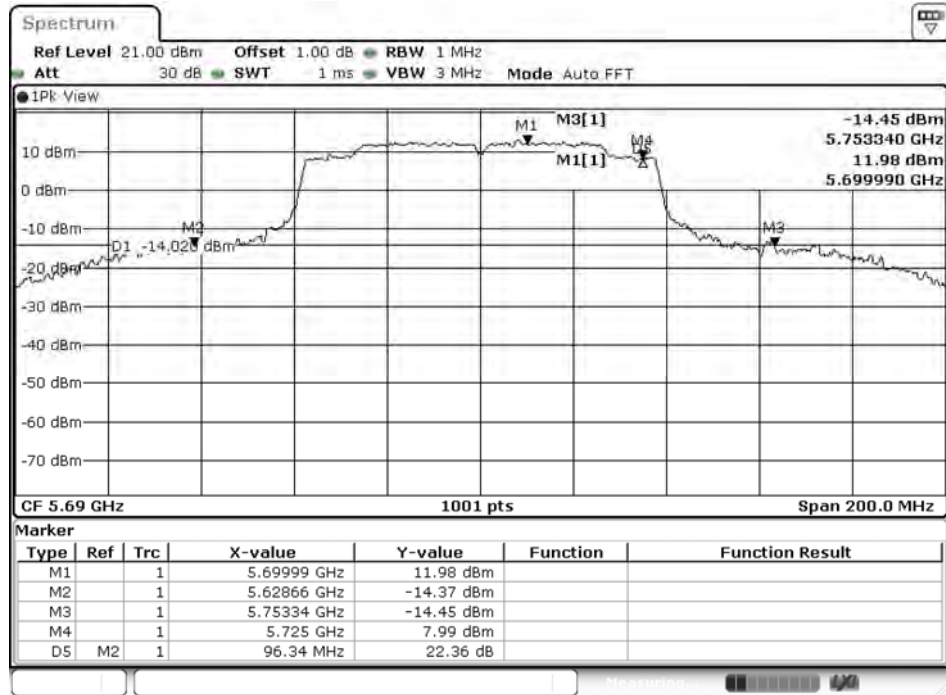

Date: 10.DEC.2019 22:08:19

Channel 138 (Chain B)

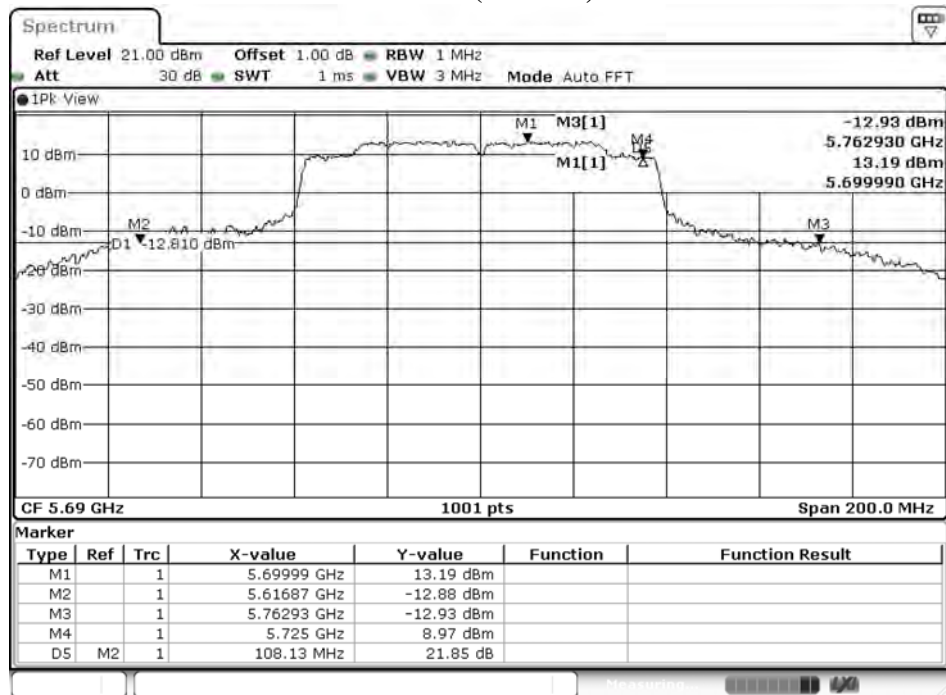

Date: 10.DEC.2019 22:04:10

**Maximum conducted output power:
Channel 138 (U-NII-2C) (Chain A)**

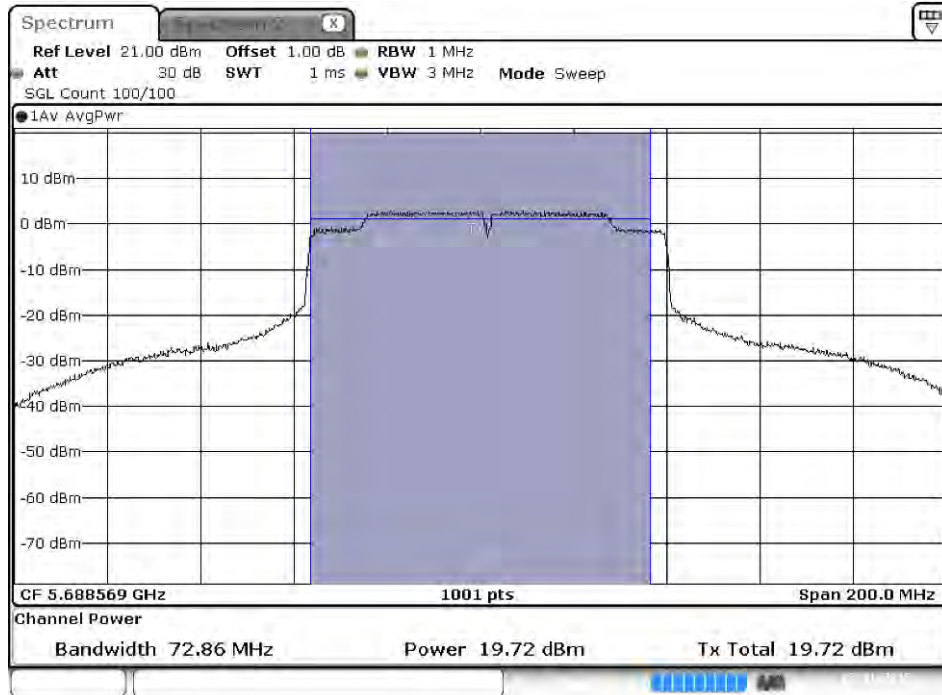

Date: 11 DEC.2019 11:52:54

**Maximum conducted output power:
Channel 138 (U-NII-3) (Chain A)**

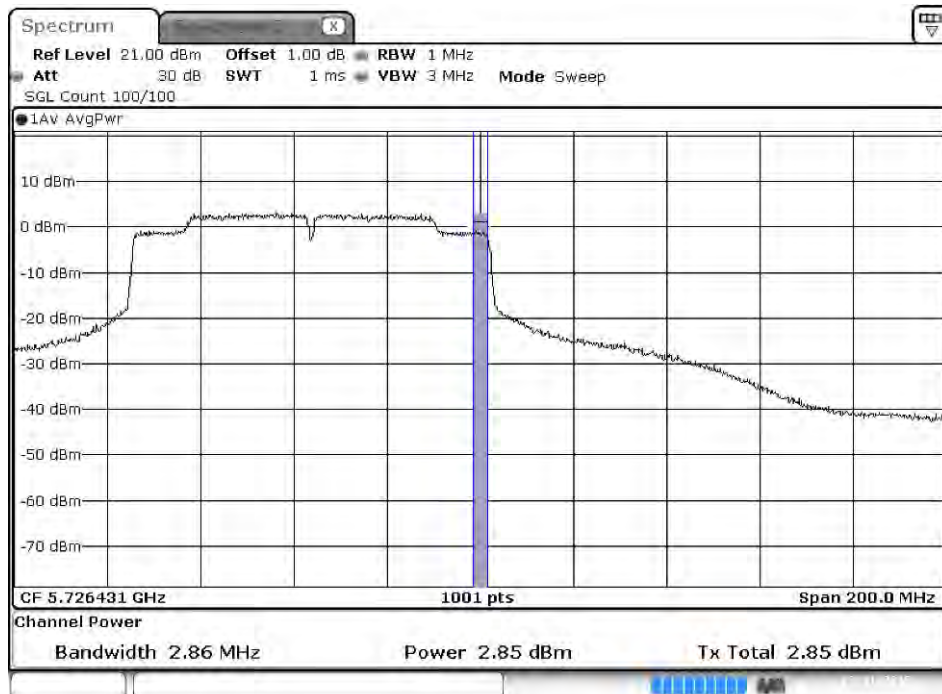

Date: 11 DEC.2019 11:53:18

**Maximum conducted output power:
Channel 138 (U-NII-2C) (Chain B)**

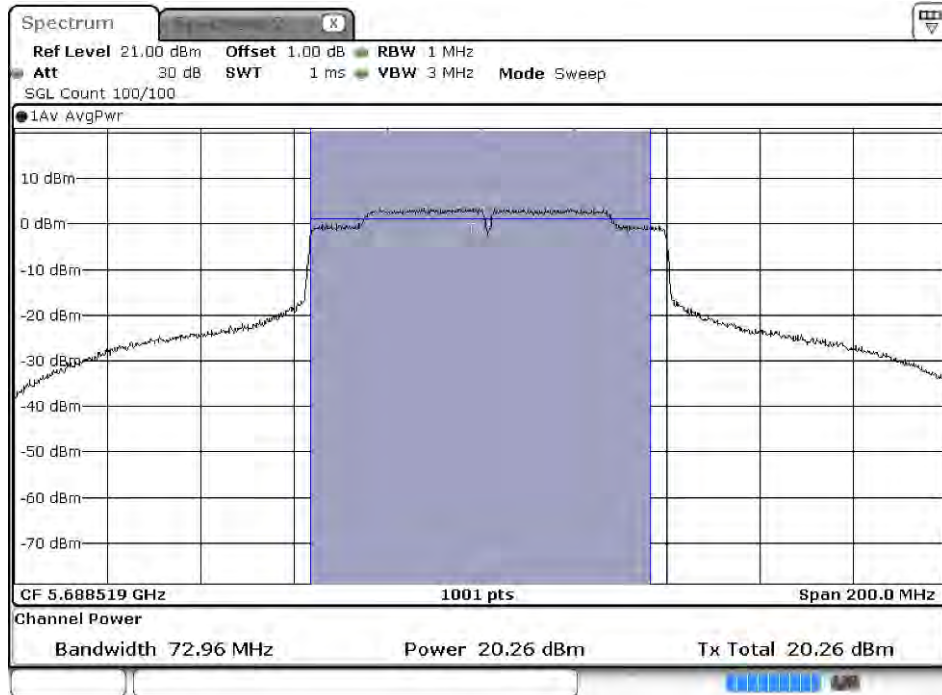

Date: 11 DEC.2019 11:55:56

**Maximum conducted output power:
Channel 138 (U-NII-3) (Chain B)**

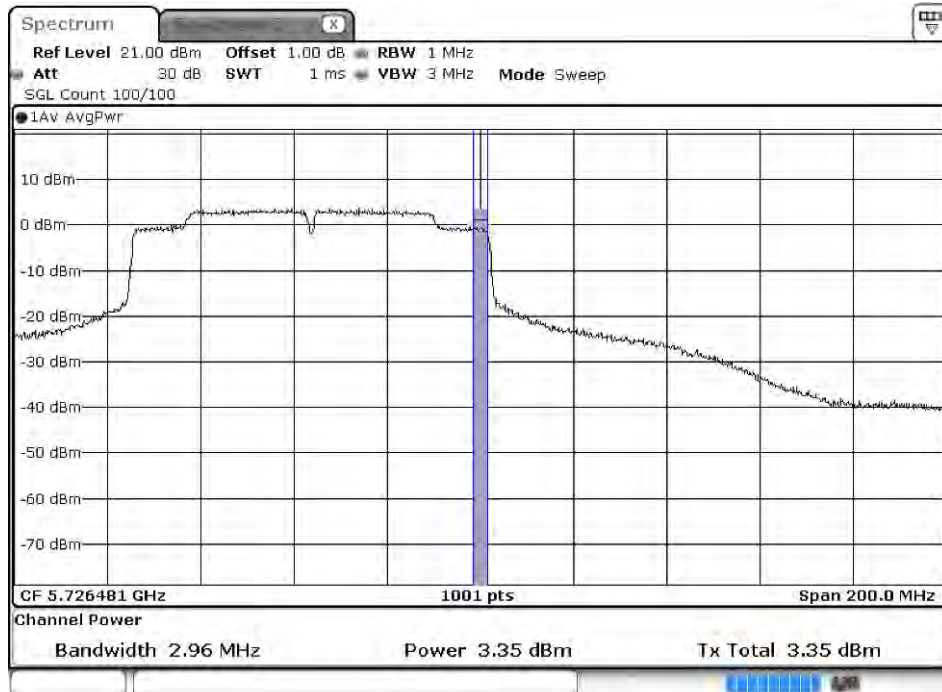

Date: 11 DEC.2019 11:56:18

Product : Intel® Wireless-AC 9560
 Test Item : Maximum conducted output power
 Test Date : 2019/12/03
 Test Mode : Mode 14 MIMO: Transmit (802.11ac-160BW_130Mbps)

Chain A

Cable loss=1.0dB		Maximum conducted output power									
Channel No	Frequency (MHz)	Data Rate (Mbps)									
		130	260	390	520	780	1040	1170	1300	1560	1733.3
50 (U-NII-1)	5250	8.15	8.11	8.06	8.02	7.98	7.94	7.91	7.85	7.80	7.75
50 (U-NII-2A)	5250	8.20	8.15	8.11	8.05	8.00	7.95	7.92	7.86	7.80	7.75
114	5570	13.10	13.05	12.99	12.96	12.91	12.84	12.79	12.74	12.69	12.65

Note: Maximum conducted output power Value =Reading value on Spectrum Analyzer + cable loss

Chain B

Cable loss=1.0dB		Maximum conducted output power									
Channel No	Frequency (MHz)	Data Rate (Mbps)									
		130	260	390	520	780	1040	1170	1300	1560	1733.3
50 (U-NII-1)	5250	8.37	8.33	8.28	8.21	8.18	8.13	8.09	8.06	8.02	7.98
50 (U-NII-2A)	5250	8.48	8.44	8.40	8.36	8.30	8.24	8.19	8.15	8.11	8.06
114	5570	13.26	13.21	13.14	13.09	13.05	12.98	12.94	12.87	12.80	12.75

Note: Maximum conducted output power Value =Reading value on Spectrum Analyzer + cable loss

Maximum conducted output power Measurement:

Channel No	Frequency Range (MHz)	26dB Bandwidth (MHz)	Chain A Power (dBm)	Chain B Power (dBm)	Output Power (dBm)	Output Power Limit		Result
						(dBm)	dBm+10log(BW)	
50(U-NII-1)	5250	--	8.15	8.37	11.27	23.36	--	Pass
50(U-NII-2A)	5250	81.725	8.20	8.48	11.35	23.63	29.75	Pass
114	5570	164.850	13.10	13.26	16.19	23.13	32.30	Pass

Note:

- Output Power (dBm) = 10LOG (Chain A Power (mW)+ Chain B Power (mW))
- 26dB Bandwidth is the bandwidth of chain A or chain B whichever is less bandwidth, output power limitation is more stringent.

26dB Occupied Bandwidth: Channel 50 (Chain A)

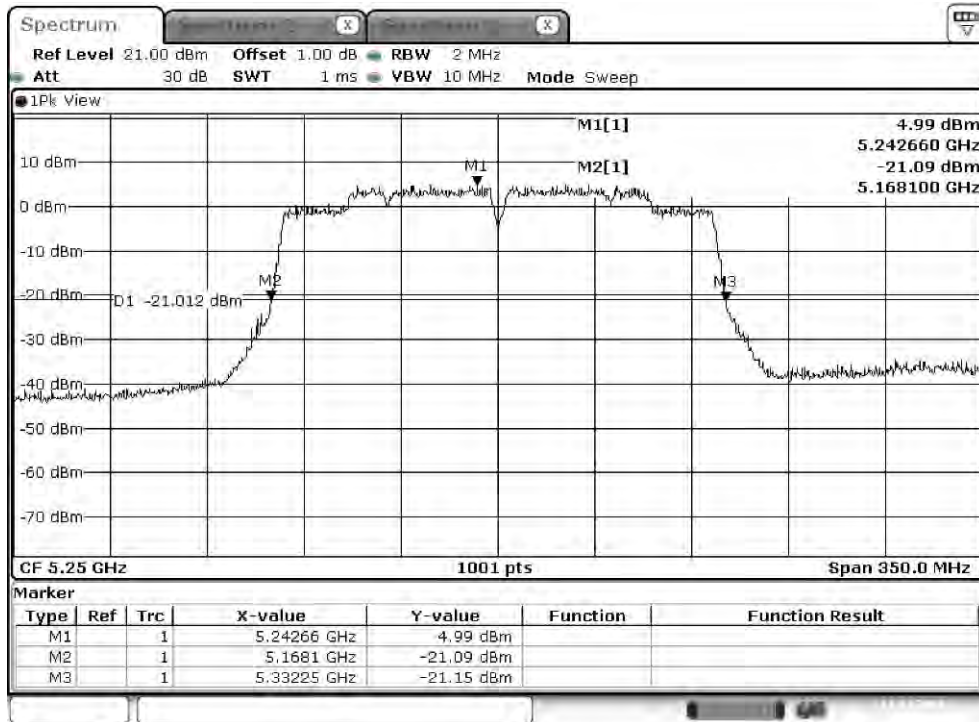

Channel 50 (Chain B)

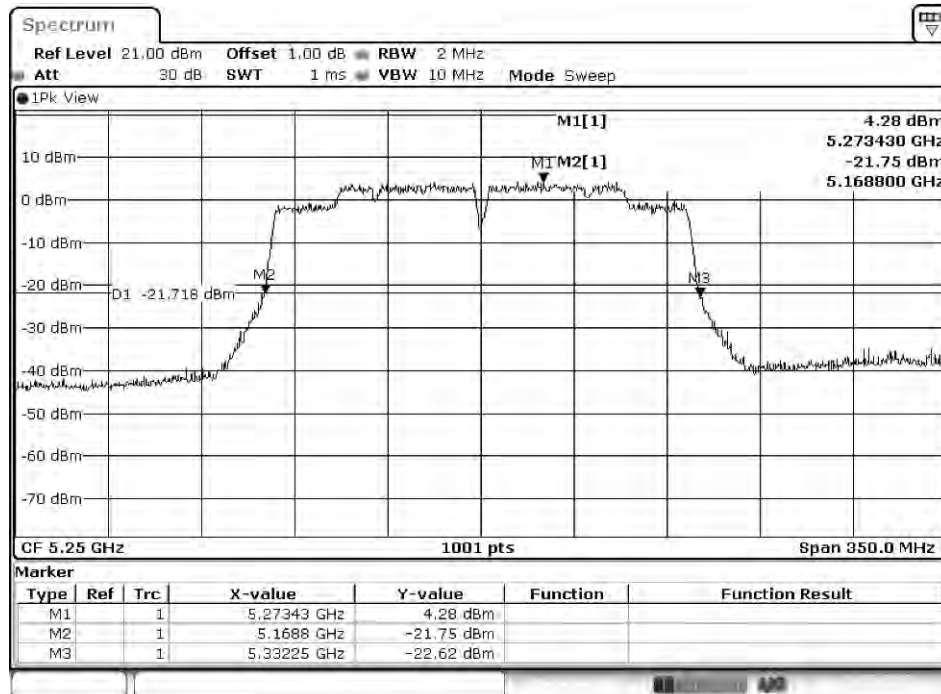

Date: 13.NOV.2019 20:35:12

Channel 114 (Chain A)

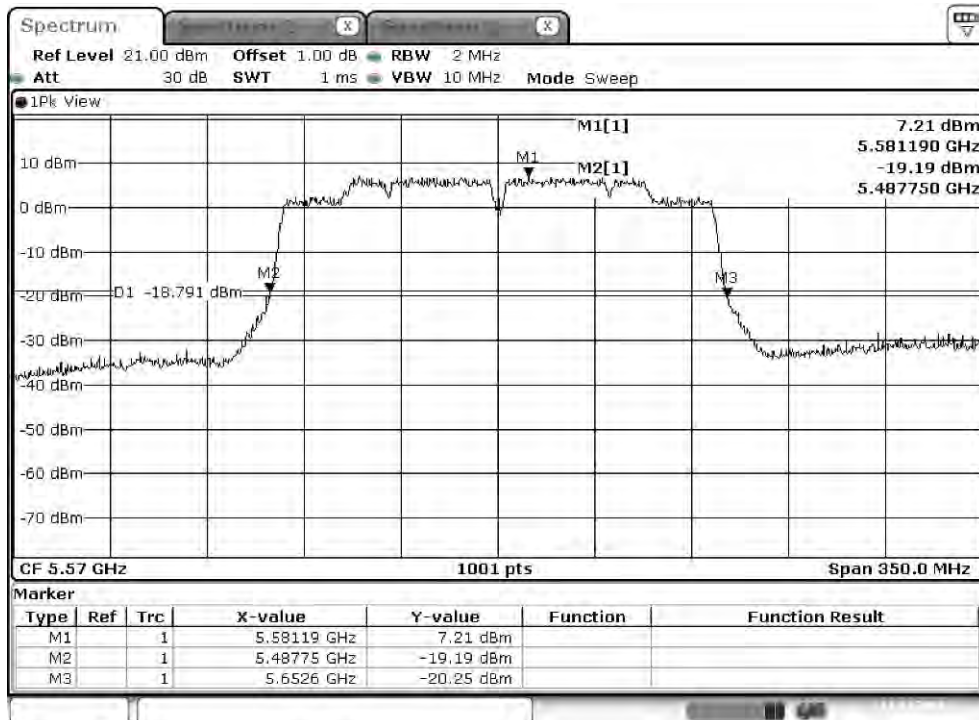

Channel 114 (Chain B)

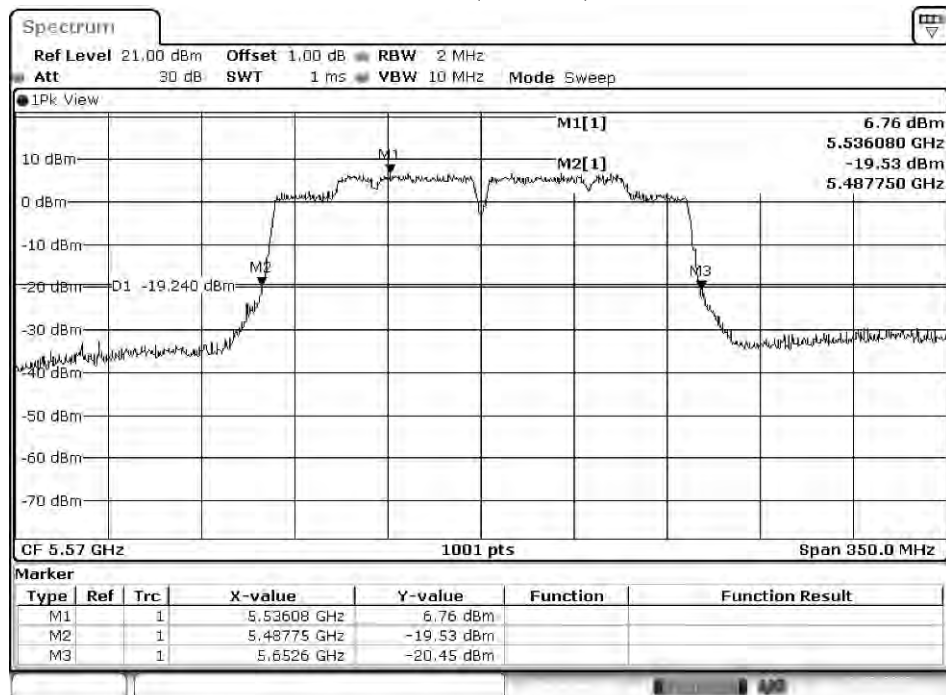

Date: 13.NOV.2019 20:39:18

Maximum conducted output power:

Channel 50 (U-NII-1) (Chain A)

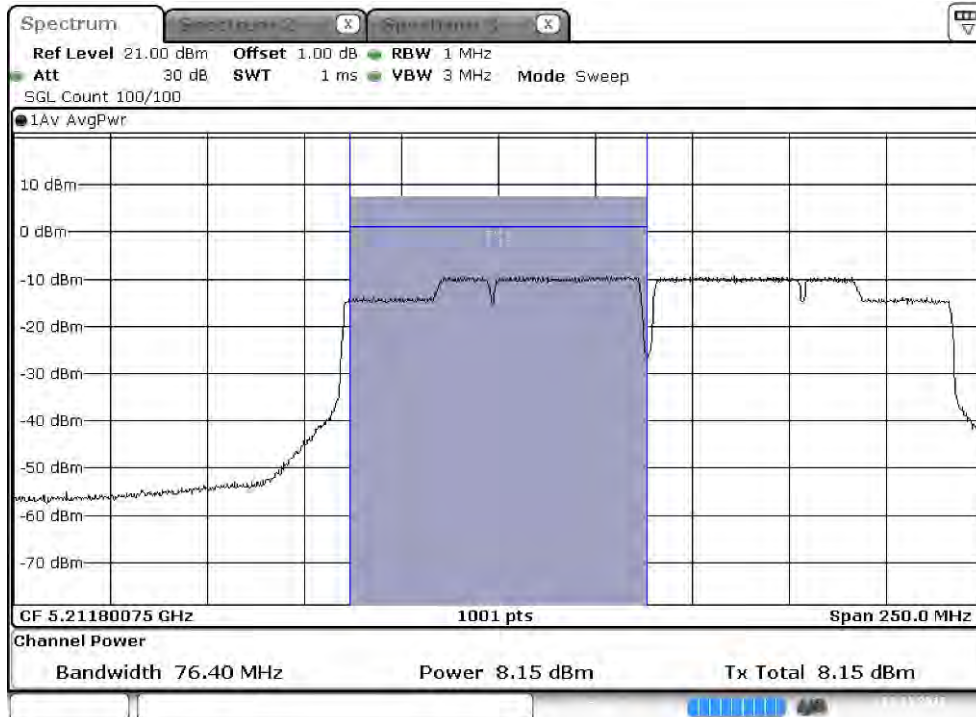

Maximum conducted output power:

Channel 50 (U-NII-2A) (Chain A)

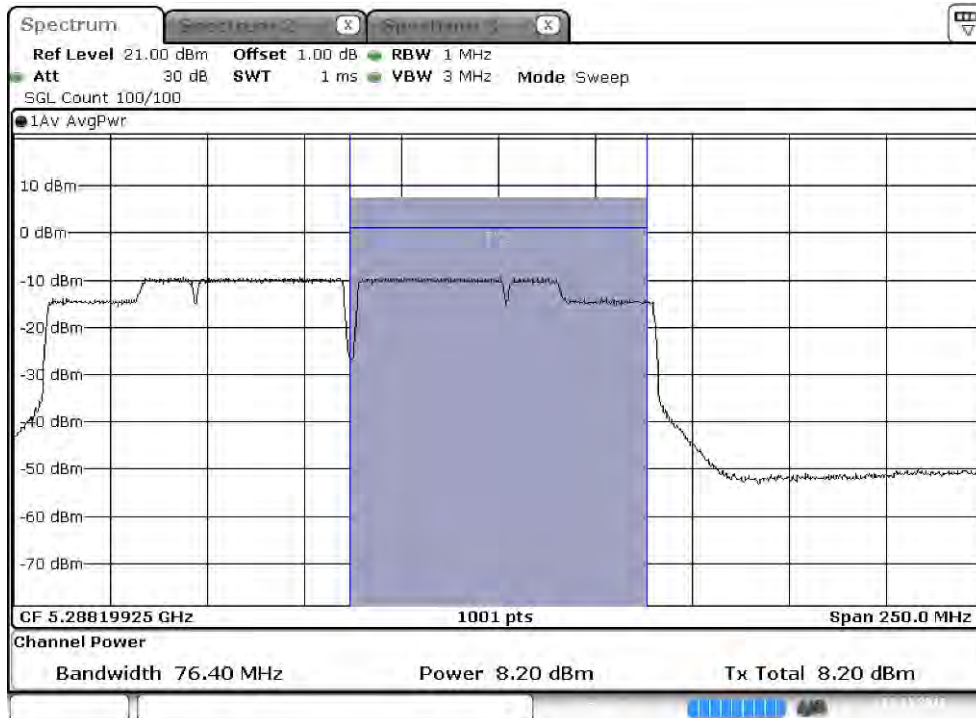

**Maximum conducted output power:
Channel 50 (U-NII-1) (Chain B)**

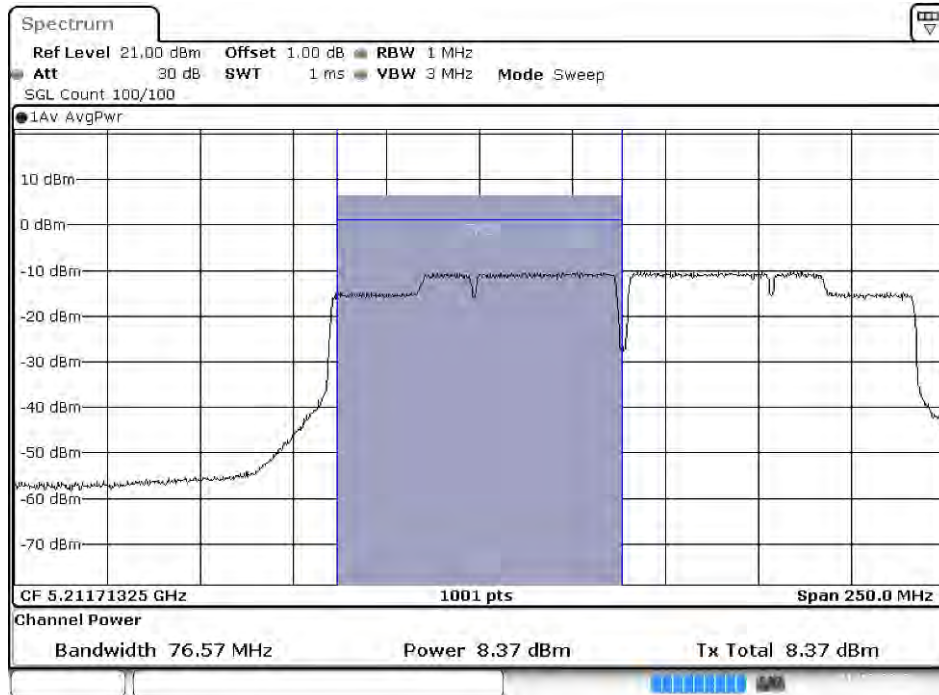

Date: 13.NOV.2019 20:35:37

**Maximum conducted output power:
Channel 50 (U-NII-2A) (Chain B)**

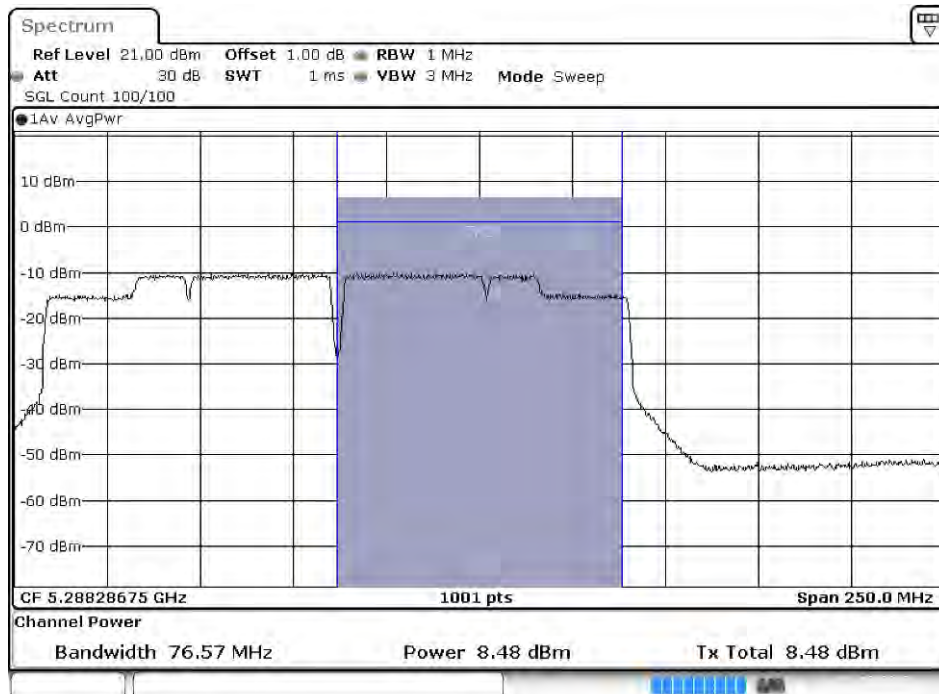

Date: 13.NOV.2019 20:36:00

3. Radiated Emission

3.1. Test Setup

Radiated Emission Under 30MHz

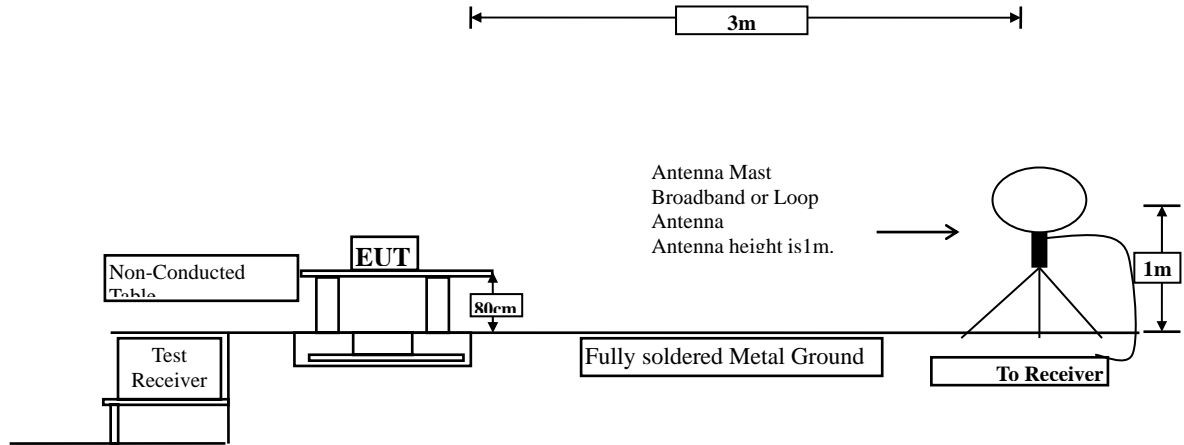

Radiated Emission Below 1GHz

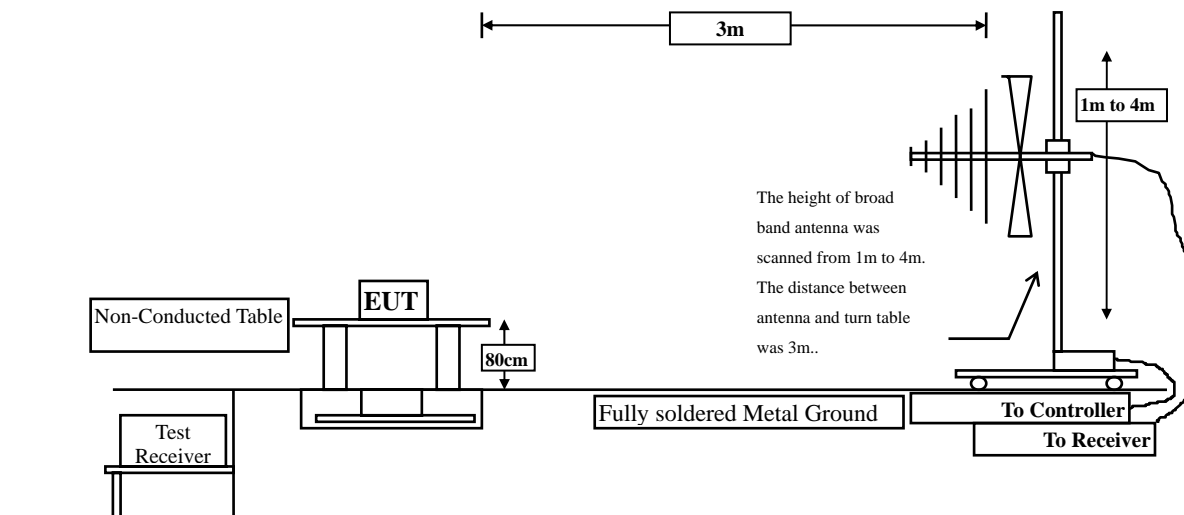

Radiated Emission Above 1GHz

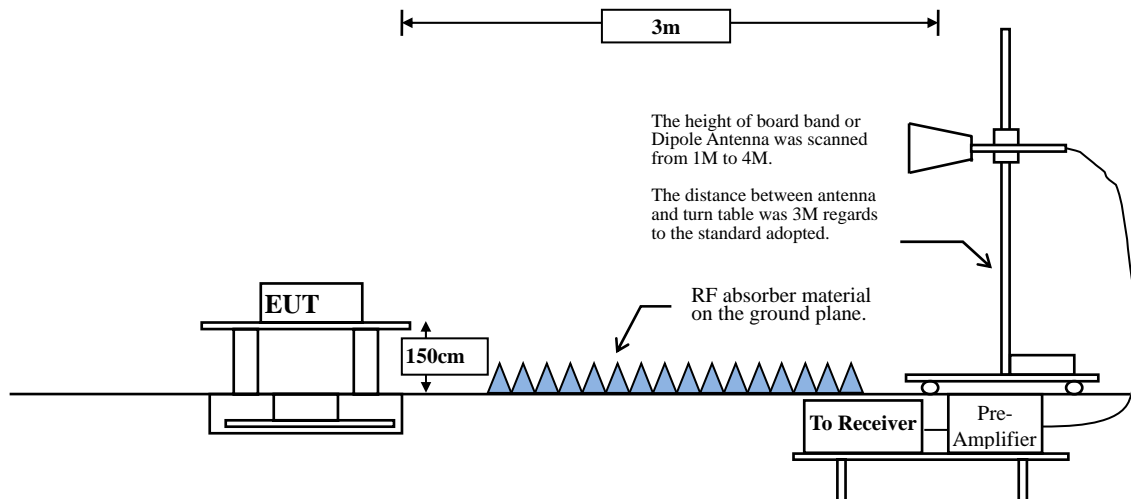

3.2. Limits

Emissions radiated outside of the specified frequency bands, except for harmonics, shall be attenuated by at least 20dB below the level of the fundamental or to the general radiated emission limits in paragraph 15.209, whichever is the lesser attenuation.

FCC Part 15 Subpart C Paragraph 15.209(a) Limits		
Frequency MHz	Field strength (microvolts/meter)	Measurement distance (meter)
0.009-0.490	2400/F(kHz)	300
0.490-1.705	24000/F(kHz)	30
1.705-30	30	30
30-88	100	3
88-216	150	3
216-960	200	3
Above 960	500	3

Remarks: E field strength (dB μ V/m) = 20 log E field strength (uV/m)

3.3. Test Procedure

The EUT was setup according to ANSI C63.10, 2013 and tested according to FCC KDB-789033 test procedure for compliance to FCC 47CFR 15. 407 requirements.

Measuring the frequency range below 1GHz, the EUT is placed on a turn table which is 0.8 meter above ground, when measuring the frequency range above 1GHz, the EUT is placed on a turn table which is 1.5 meter above ground.

The turn table is rotated 360 degrees to determine the position of the maximum emission level.

The EUT was positioned such that the distance from antenna to the EUT was 3 meters.

The antenna is scanned between 1 meter and 4 meters to find out the maximum emission level. This is repeated for both horizontal and vertical polarization of the antenna. In order to find the maximum emission, all of the interface cables were manipulated according to ANSI C63.10: 2013 on radiated measurement.

The resolution bandwidth below 30MHz setting on the field strength meter is 9kHz and 30MHz~1GHz is 120kHz and above 1GHz is 1MHz.

Radiated emission measurements below 30MHz are made using Loop Antenna and 30MHz~1GHz are made using broadband Bilog antenna and above 1GHz are made using Horn Antennas.

The measurement is divided into the Preliminary Measurement and the Final Measurement.

The suspected frequencies are searched for in Preliminary Measurement with the measurement antenna kept pointed at the source of the emission both in azimuth and elevation, with the polarization of the antenna oriented for maximum response. The antenna is pointed at an angle towards the source of the emission, and the EUT is rotated in both height and polarization to maximize the measured emission. The emission is kept within the illumination area of the 3 dB bandwidth of the antenna. The measurement frequency range from 9kHz - 10th Harmonic of fundamental was investigated.

RBW and VBW Parameter setting:

According to KDB 789033 section II.G.5 Procedure for Unwanted Maximum Emissions Measurements above 1000 MHz.

RBW = 1MHz.

VBW \geq 3MHz.

According to KDB 789033 section II.G.6 Procedures for Average Unwanted Emissions Measurements above 1000 MHz.

RBW = 1MHz.

VBW = 10Hz, when duty cycle \geq 98 %

VBW \geq 1/T, when duty cycle < 98 %

(T refers to the minimum transmission duration over which the transmitter is on and is transmitting at its maximum power control level for the tested mode of operation.)

SISO A

5GHz band	Duty Cycle (%)	T (ms)	1/T (Hz)	VBW (Hz)
802.11a	98.80	2.0650	484	10
802.11n20	99.64	37.3450	27	10
802.11n40	99.81	17.9450	56	10
802.11ac80	99.46	11.0700	90	10
802.11ac160	99.37	5.5450	180	10

Note: Duty Cycle Refer to Section 5

SISO B

5GHz band	Duty Cycle (%)	T (ms)	1/T (Hz)	VBW (Hz)
802.11a	99.04	2.0700	483	10
802.11n20	99.41	37.1700	27	10
802.11n40	99.33	17.9200	56	10
802.11ac80	99.55	11.0900	90	10
802.11ac160	99.64	5.5600	180	10

Note: Duty Cycle Refer to Section 5

MIMO

5GHz band	Duty Cycle (%)	T (ms)	1/T (Hz)	VBW (Hz)
802.11n20	99.47	18.6000	54	10
802.11n40	99.34	8.9900	111	10
802.11ac80	99.28	5.5500	180	10
802.11ac160	98.94	2.8100	356	10

Note: Duty Cycle Refer to Section 5

3.4. Uncertainty

Horizontal polarization :

30-300MHz: ± 4.08 dB ; 300M-1GHz: ± 3.86 dB ; 1-18GHz: ± 3.77 dB ; 18-40GHz: ± 3.98 dB

Vertical polarization :

30-300MHz: ± 4.81 dB ; 300M-1GHz: ± 3.87 dB ; 1-18GHz : ± 3.83 dB ; 18-40GHz: ± 3.98 dB

3.5. Test Result of Radiated Emission

Product : Intel® Wireless-AC 9560
 Test Item : Harmonic Radiated Emission Data
 Test Date : 2019/11/25
 Test Mode : Mode 1 SISO A: Transmit (802.11a_6Mbps) (5180MHz)

Horizontal

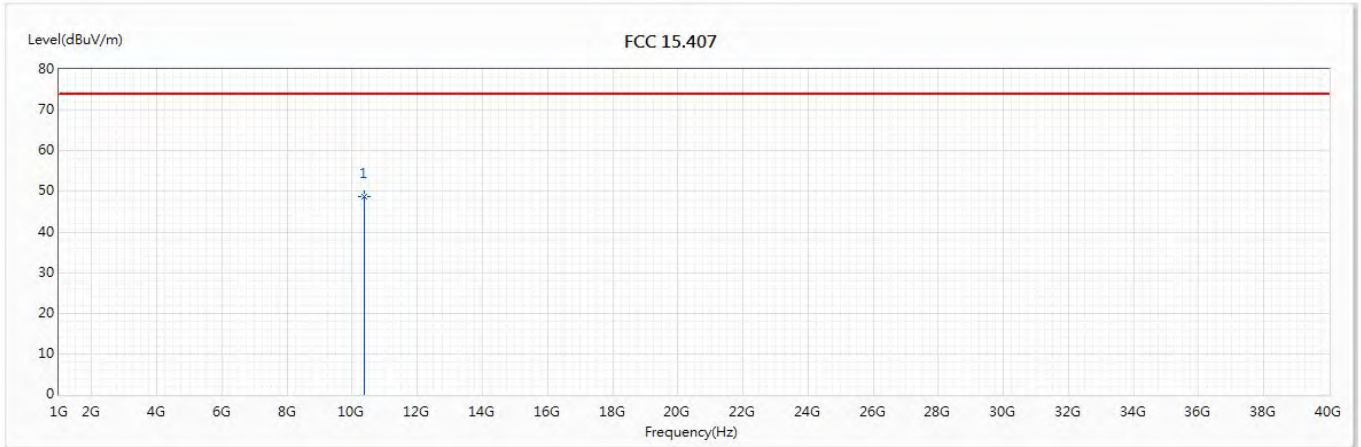

No	Frequency (MHz)	Emission Level (dBuV/m)	Limit (dBuV/m)	Margin (dB)	Reading Level (dBuV)	Correct Factor (dB/m)	Detector Type
* 1	10360	48.61	74.00	-25.39	46.12	2.49	PK

Note:

1. All Readings below 1GHz are Quasi-Peak, above 1GHz are performed with peak and/or average measurements as necessary.
2. Measurement Level = Reading Level + Correct Factor.
3. Correct Factor = Antenna factor + Cable loss – Amplifier gain.
4. The average measurement was not performed when the peak measured data under the limit of average detection.
5. The emission levels of other frequencies are very lower than the limit and not show in test report.

Product : Intel® Wireless-AC 9560
 Test Item : Harmonic Radiated Emission Data
 Test Date : 2019/11/25
 Test Mode : Mode 1 SISO A: Transmit (802.11a_6Mbps) (5180MHz)

Vertical

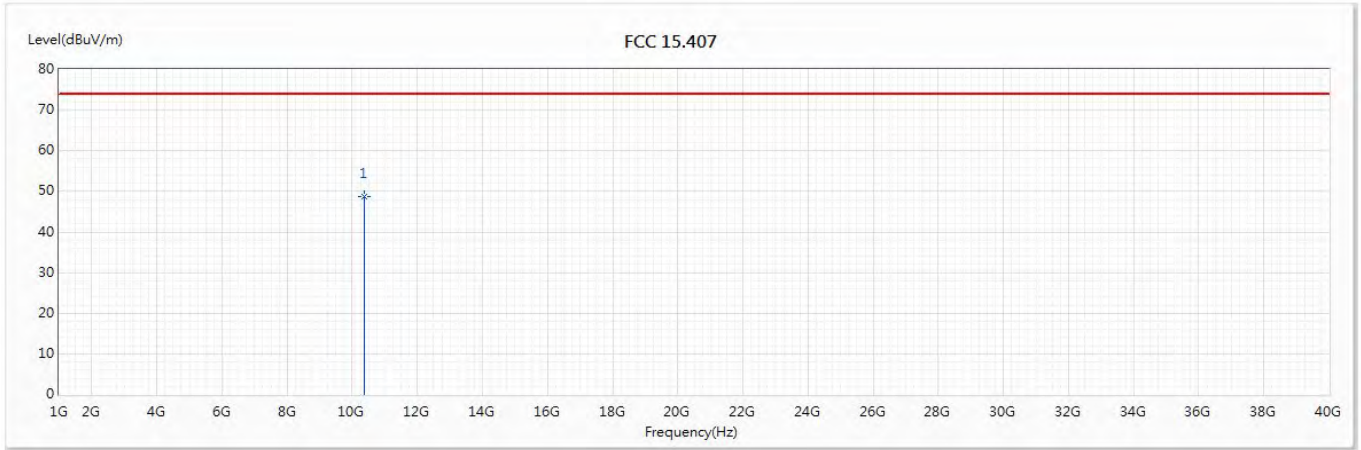

No	Frequency (MHz)	Emission Level (dBuV/m)	Limit (dBuV/m)	Margin (dB)	Reading Level (dBuV)	Correct Factor (dB/m)	Detector Type
* 1	10360	48.73	74.00	-25.27	46.24	2.49	PK

Note:

1. All Readings below 1GHz are Quasi-Peak, above 1GHz are performed with peak and/or average measurements as necessary.
2. Measurement Level = Reading Level + Correct Factor.
3. Correct Factor = Antenna factor + Cable loss – Amplifier gain.
4. The average measurement was not performed when the peak measured data under the limit of average detection.
5. The emission levels of other frequencies are very lower than the limit and not show in test report.

Product : Intel® Wireless-AC 9560
 Test Item : Harmonic Radiated Emission Data
 Test Date : 2019/11/25
 Test Mode : Mode 1 SISO A: Transmit (802.11a_6Mbps) (5220MHz)

Horizontal

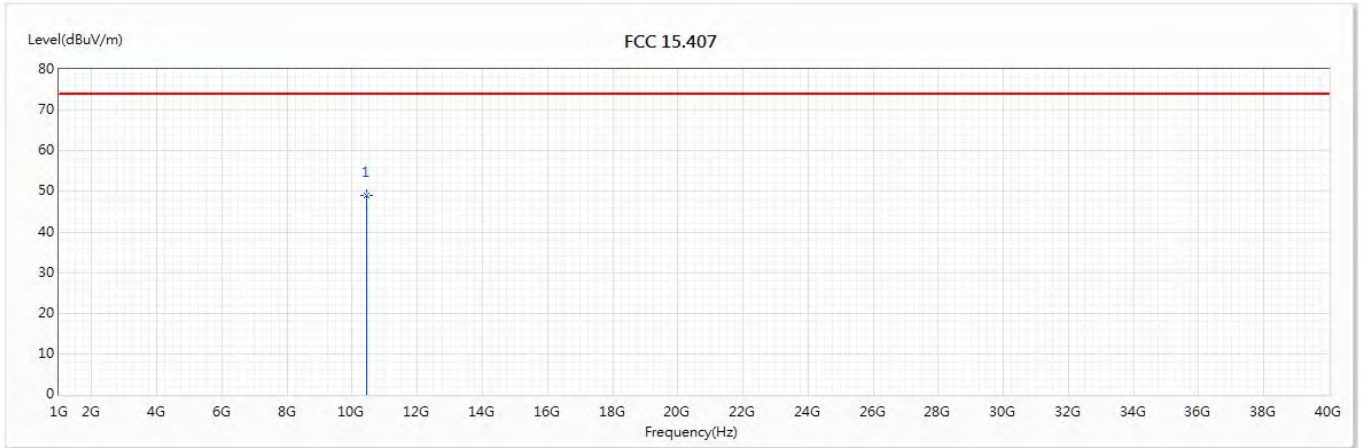

No	Frequency (MHz)	Emission Level (dBuV/m)	Limit (dBuV/m)	Margin (dB)	Reading Level (dBuV)	Correct Factor (dB/m)	Detector Type
* 1	10440	49.02	74.00	-24.98	46.26	2.76	PK

Note:

1. All Readings below 1GHz are Quasi-Peak, above 1GHz are performed with peak and/or average measurements as necessary.
2. Measurement Level = Reading Level + Correct Factor.
3. Correct Factor = Antenna factor + Cable loss – Amplifier gain.
4. The average measurement was not performed when the peak measured data under the limit of average detection.
5. The emission levels of other frequencies are very lower than the limit and not show in test report.

Product : Intel® Wireless-AC 9560
 Test Item : Harmonic Radiated Emission Data
 Test Date : 2019/11/25
 Test Mode : Mode 1 SISO A: Transmit (802.11a_6Mbps) (5220MHz)

Vertical

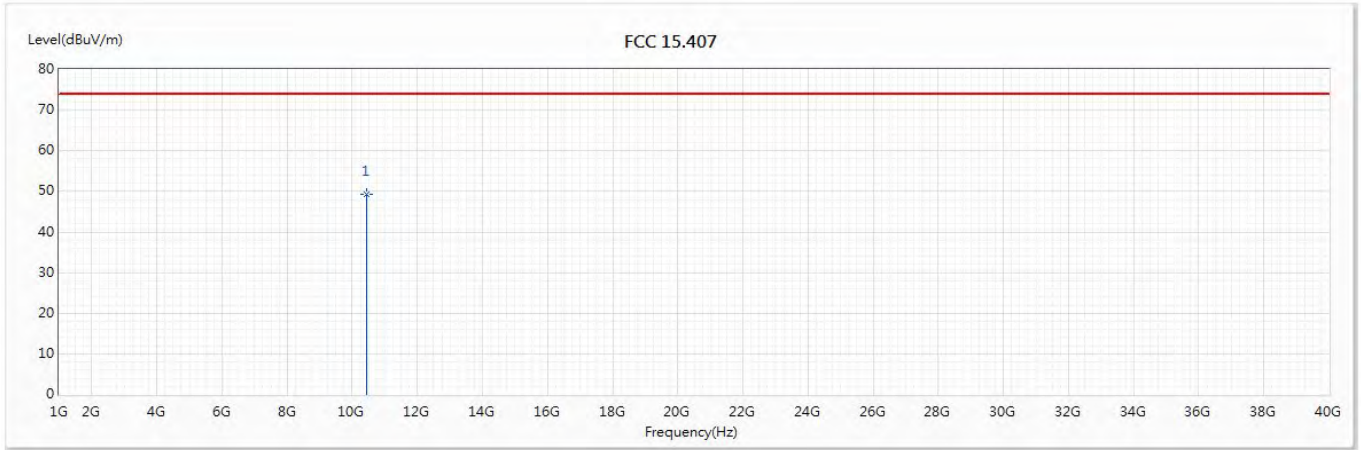

No	Frequency (MHz)	Emission Level (dBuV/m)	Limit (dBuV/m)	Margin (dB)	Reading Level (dBuV)	Correct Factor (dB/m)	Detector Type
* 1	10440	49.29	74.00	-24.71	46.53	2.76	PK

Note:

1. All Readings below 1GHz are Quasi-Peak, above 1GHz are performed with peak and/or average measurements as necessary.
2. Measurement Level = Reading Level + Correct Factor.
3. Correct Factor = Antenna factor + Cable loss – Amplifier gain.
4. The average measurement was not performed when the peak measured data under the limit of average detection.
5. The emission levels of other frequencies are very lower than the limit and not show in test report.

Product : Intel® Wireless-AC 9560
 Test Item : Harmonic Radiated Emission Data
 Test Date : 2019/11/26
 Test Mode : Mode 1 SISO A: Transmit (802.11a_6Mbps) (5240MHz)

Horizontal

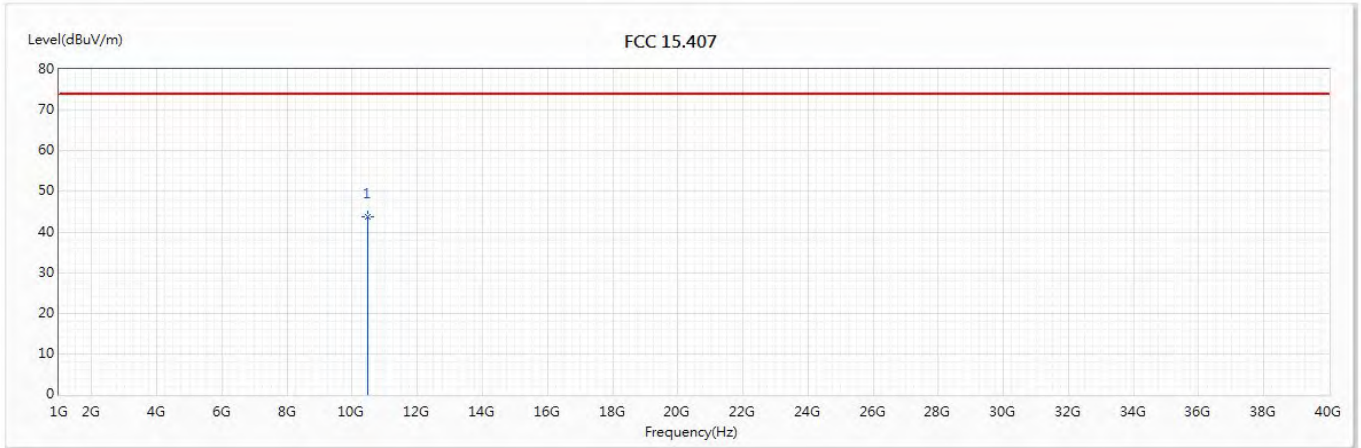

No	Frequency (MHz)	Emission Level (dBuV/m)	Limit (dBuV/m)	Margin (dB)	Reading Level (dBuV)	Correct Factor (dB/m)	Detector Type
* 1	10480	43.63	74.00	-30.37	40.92	2.71	PK

Note:

1. All Readings below 1GHz are Quasi-Peak, above 1GHz are performed with peak and/or average measurements as necessary.
2. Measurement Level = Reading Level + Correct Factor.
3. Correct Factor = Antenna factor + Cable loss – Amplifier gain.
4. The average measurement was not performed when the peak measured data under the limit of average detection.
5. The emission levels of other frequencies are very lower than the limit and not show in test report.

Product : Intel® Wireless-AC 9560
 Test Item : Harmonic Radiated Emission Data
 Test Date : 2019/11/26
 Test Mode : Mode 1 SISO A: Transmit (802.11a_6Mbps) (5240MHz)

Vertical

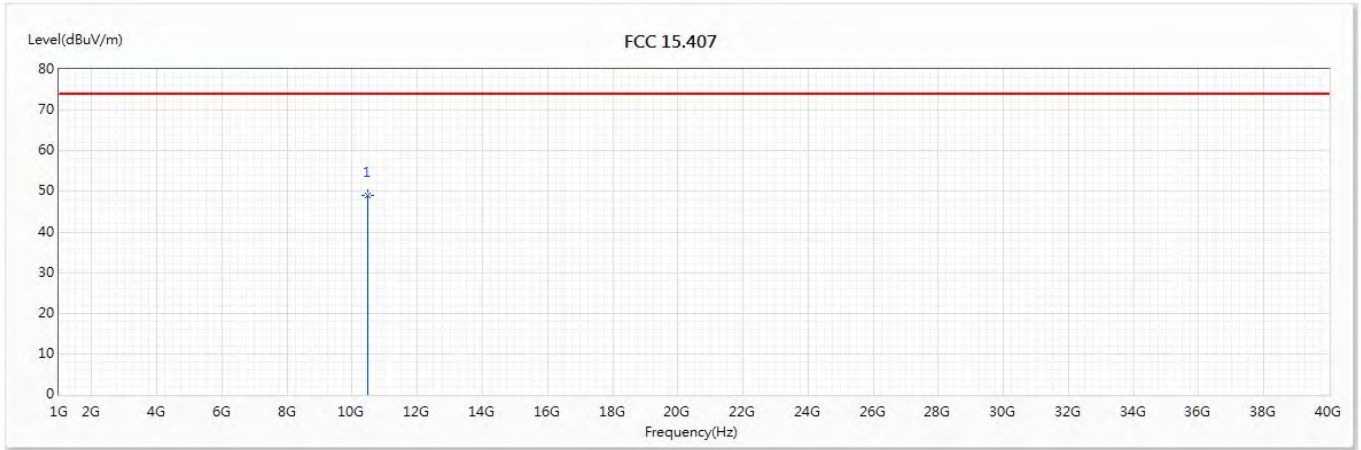

No	Frequency (MHz)	Emission Level (dBuV/m)	Limit (dBuV/m)	Margin (dB)	Reading Level (dBuV)	Correct Factor (dB/m)	Detector Type
* 1	10480	49.12	74.00	-24.88	46.41	2.71	PK

Note:

1. All Readings below 1GHz are Quasi-Peak, above 1GHz are performed with peak and/or average measurements as necessary.
2. Measurement Level = Reading Level + Correct Factor.
3. Correct Factor = Antenna factor + Cable loss – Amplifier gain.
4. The average measurement was not performed when the peak measured data under the limit of average detection.
5. The emission levels of other frequencies are very lower than the limit and not show in test report.

Product : Intel® Wireless-AC 9560
 Test Item : Harmonic Radiated Emission Data
 Test Date : 2019/11/26
 Test Mode : Mode 1 SISO A: Transmit (802.11a_6Mbps) (5260MHz)

Horizontal

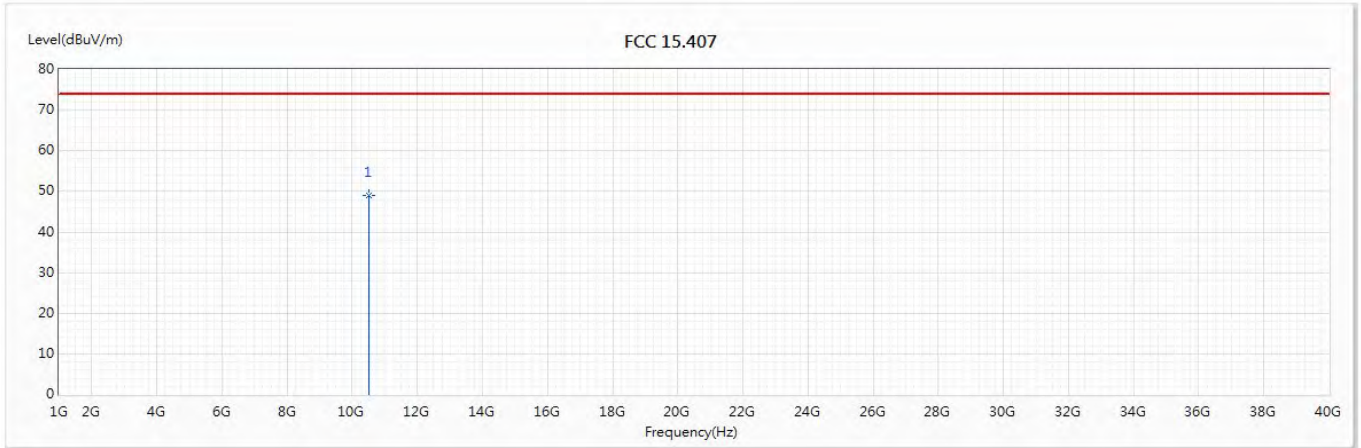

No	Frequency (MHz)	Emission Level (dBuV/m)	Limit (dBuV/m)	Margin (dB)	Reading Level (dBuV)	Correct Factor (dB/m)	Detector Type
* 1	10520	48.86	74.00	-25.14	46.35	2.51	PK

Note:

1. All Readings below 1GHz are Quasi-Peak, above 1GHz are performed with peak and/or average measurements as necessary.
2. Measurement Level = Reading Level + Correct Factor.
3. Correct Factor = Antenna factor + Cable loss – Amplifier gain.
4. The average measurement was not performed when the peak measured data under the limit of average detection.
5. The emission levels of other frequencies are very lower than the limit and not show in test report.

Product : Intel® Wireless-AC 9560
 Test Item : Harmonic Radiated Emission Data
 Test Date : 2019/11/26
 Test Mode : Mode 1 SISO A: Transmit (802.11a_6Mbps) (5260MHz)

Vertical

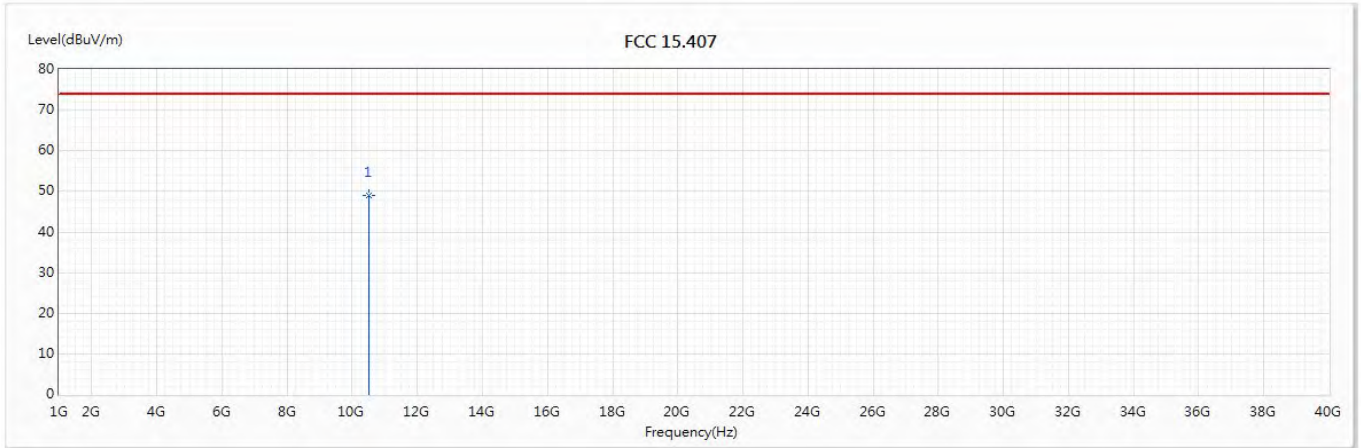

No	Frequency (MHz)	Emission Level (dBuV/m)	Limit (dBuV/m)	Margin (dB)	Reading Level (dBuV)	Correct Factor (dB/m)	Detector Type
* 1	10520	48.94	74.00	-25.06	46.43	2.51	PK

Note:

1. All Readings below 1GHz are Quasi-Peak, above 1GHz are performed with peak and/or average measurements as necessary.
2. Measurement Level = Reading Level + Correct Factor.
3. Correct Factor = Antenna factor + Cable loss – Amplifier gain.
4. The average measurement was not performed when the peak measured data under the limit of average detection.
5. The emission levels of other frequencies are very lower than the limit and not show in test report.

Product : Intel® Wireless-AC 9560
 Test Item : Harmonic Radiated Emission Data
 Test Date : 2019/11/26
 Test Mode : Mode 1 SISO A: Transmit (802.11a_6Mbps) (5300MHz)

Horizontal

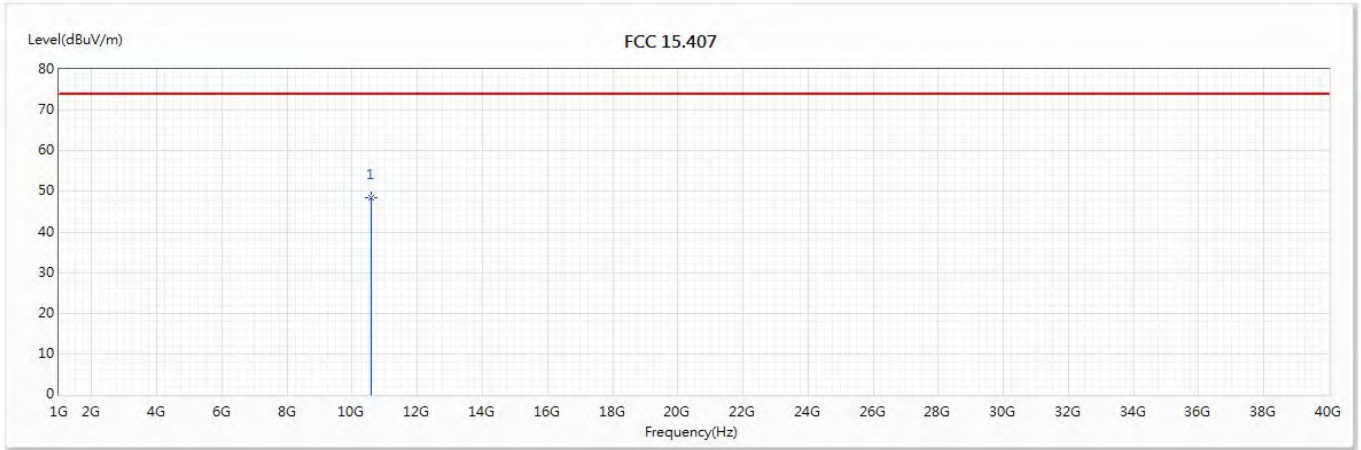

No	Frequency (MHz)	Emission Level (dBuV/m)	Limit (dBuV/m)	Margin (dB)	Reading Level (dBuV)	Correct Factor (dB/m)	Detector Type
* 1	10600	48.53	74.00	-25.47	45.53	3.00	PK

Note:

1. All Readings below 1GHz are Quasi-Peak, above 1GHz are performed with peak and/or average measurements as necessary.
2. Measurement Level = Reading Level + Correct Factor.
3. Correct Factor = Antenna factor + Cable loss –Amplifier gain.
4. The average measurement was not performed when the peak measured data under the limit of average detection.
5. The emission levels of other frequencies are very lower than the limit and not show in test report.

Product : Intel® Wireless-AC 9560
 Test Item : Harmonic Radiated Emission Data
 Test Date : 2019/11/26
 Test Mode : Mode 1 SISO A: Transmit (802.11a_6Mbps) (5300MHz)

Vertical

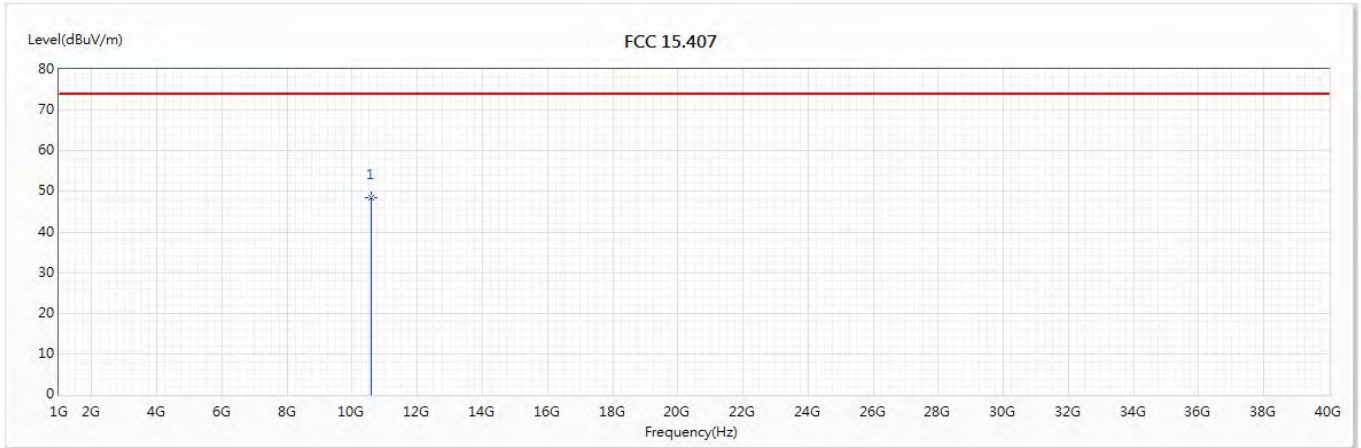

No	Frequency (MHz)	Emission Level (dBuV/m)	Limit (dBuV/m)	Margin (dB)	Reading Level (dBuV)	Correct Factor (dB/m)	Detector Type
* 1	10600	48.53	74.00	-25.47	45.53	3.00	PK

Note:

1. All Readings below 1GHz are Quasi-Peak, above 1GHz are performed with peak and/or average measurements as necessary.
2. Measurement Level = Reading Level + Correct Factor.
3. Correct Factor = Antenna factor + Cable loss – Amplifier gain.
4. The average measurement was not performed when the peak measured data under the limit of average detection.
5. The emission levels of other frequencies are very lower than the limit and not show in test report.

Product : Intel® Wireless-AC 9560
 Test Item : Harmonic Radiated Emission Data
 Test Date : 2019/11/26
 Test Mode : Mode 1 SISO A: Transmit (802.11a_6Mbps) (5320MHz)

Horizontal

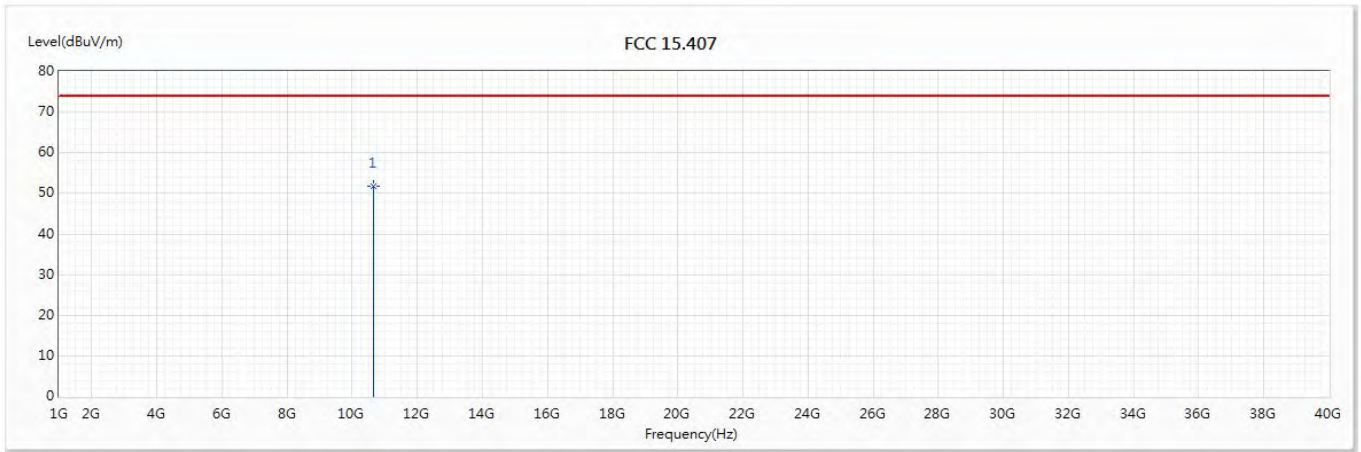

No	Frequency (MHz)	Emission Level (dBuV/m)	Limit (dBuV/m)	Margin (dB)	Reading Level (dBuV)	Correct Factor (dB/m)	Detector Type
* 1	10640	51.65	74.00	-22.35	48.84	2.81	PK

Note:

1. All Readings below 1GHz are Quasi-Peak, above 1GHz are performed with peak and/or average measurements as necessary.
2. Measurement Level = Reading Level + Correct Factor.
3. Correct Factor = Antenna factor + Cable loss – Amplifier gain.
4. The average measurement was not performed when the peak measured data under the limit of average detection.
5. The emission levels of other frequencies are very lower than the limit and not show in test report.

Product : Intel® Wireless-AC 9560
 Test Item : Harmonic Radiated Emission Data
 Test Date : 2019/11/26
 Test Mode : Mode 1 SISO A: Transmit (802.11a_6Mbps) (5320MHz)

Vertical

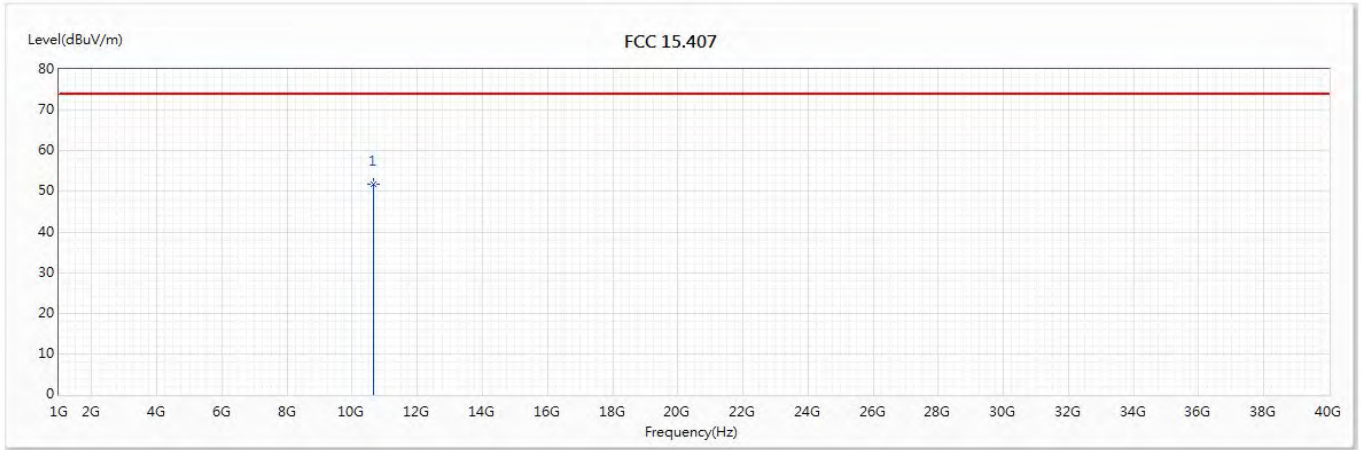

No	Frequency (MHz)	Emission Level (dBuV/m)	Limit (dBuV/m)	Margin (dB)	Reading Level (dBuV)	Correct Factor (dB/m)	Detector Type
* 1	10640	51.66	74.00	-22.34	48.85	2.81	PK

Note:

1. All Readings below 1GHz are Quasi-Peak, above 1GHz are performed with peak and/or average measurements as necessary.
2. Measurement Level = Reading Level + Correct Factor.
3. Correct Factor = Antenna factor + Cable loss – Amplifier gain.
4. The average measurement was not performed when the peak measured data under the limit of average detection.
5. The emission levels of other frequencies are very lower than the limit and not show in test report.

Product : Intel® Wireless-AC 9560
 Test Item : Harmonic Radiated Emission Data
 Test Date : 2019/11/26
 Test Mode : Mode 1 SISO A: Transmit (802.11a_6Mbps) (5500MHz)

Horizontal

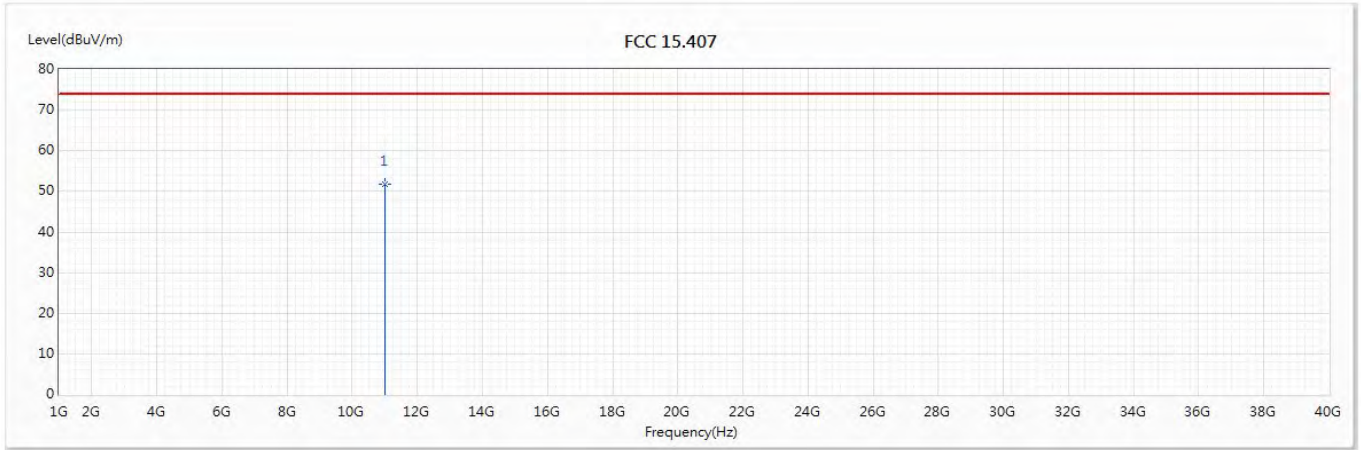

No	Frequency (MHz)	Emission Level (dBuV/m)	Limit (dBuV/m)	Margin (dB)	Reading Level (dBuV)	Correct Factor (dB/m)	Detector Type
* 1	11000	51.66	74.00	-22.34	48.32	3.34	PK

Note:

1. All Readings below 1GHz are Quasi-Peak, above 1GHz are performed with peak and/or average measurements as necessary.
2. Measurement Level = Reading Level + Correct Factor.
3. Correct Factor = Antenna factor + Cable loss – Amplifier gain.
4. The average measurement was not performed when the peak measured data under the limit of average detection.
5. The emission levels of other frequencies are very lower than the limit and not show in test report.

Product : Intel® Wireless-AC 9560
 Test Item : Harmonic Radiated Emission Data
 Test Date : 2019/11/26
 Test Mode : Mode 1 SISO A: Transmit (802.11a_6Mbps) (5500MHz)

Vertical

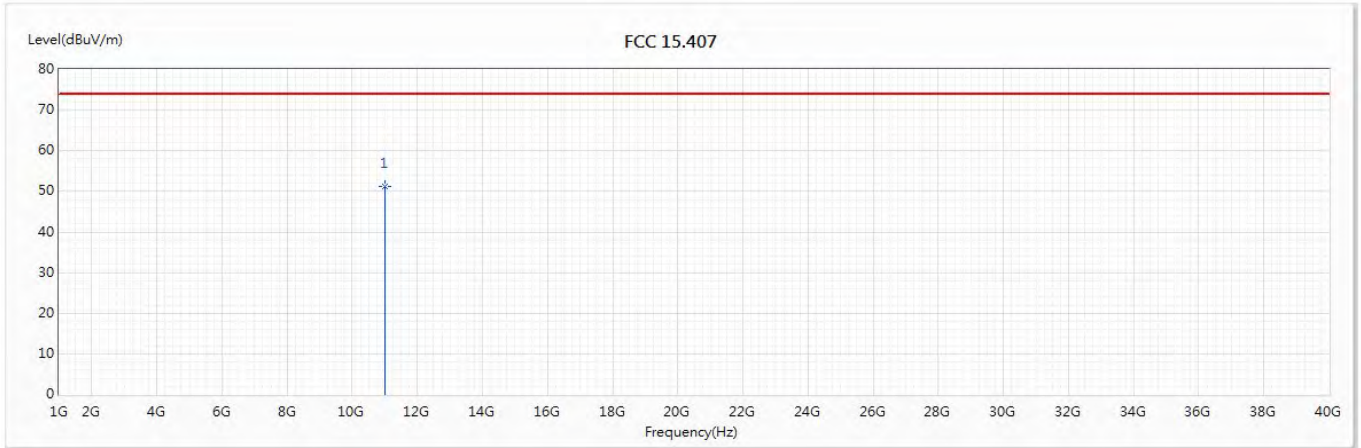

No	Frequency (MHz)	Emission Level (dBuV/m)	Limit (dBuV/m)	Margin (dB)	Reading Level (dBuV)	Correct Factor (dB/m)	Detector Type
* 1	11000	51.28	74.00	-22.72	47.94	3.34	PK

Note:

1. All Readings below 1GHz are Quasi-Peak, above 1GHz are performed with peak and/or average measurements as necessary.
2. Measurement Level = Reading Level + Correct Factor.
3. Correct Factor = Antenna factor + Cable loss – Amplifier gain.
4. The average measurement was not performed when the peak measured data under the limit of average detection.
5. The emission levels of other frequencies are very lower than the limit and not show in test report.

Product : Intel® Wireless-AC 9560
 Test Item : Harmonic Radiated Emission Data
 Test Date : 2019/11/26
 Test Mode : Mode 1 SISO A: Transmit (802.11a_6Mbps) (5580MHz)

Horizontal

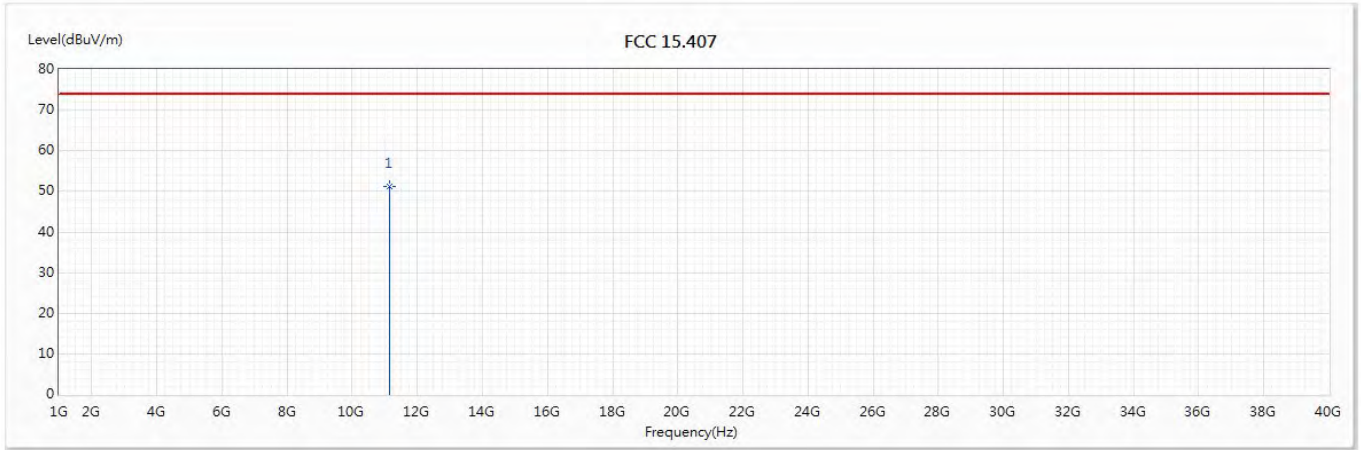

No	Frequency (MHz)	Emission Level (dBuV/m)	Limit (dBuV/m)	Margin (dB)	Reading Level (dBuV)	Correct Factor (dB/m)	Detector Type
* 1	11160	51.28	74.00	-22.72	47.64	3.64	PK

Note:

1. All Readings below 1GHz are Quasi-Peak, above 1GHz are performed with peak and/or average measurements as necessary.
2. Measurement Level = Reading Level + Correct Factor.
3. Correct Factor = Antenna factor + Cable loss – Amplifier gain.
4. The average measurement was not performed when the peak measured data under the limit of average detection.
5. The emission levels of other frequencies are very lower than the limit and not show in test report.

Product : Intel® Wireless-AC 9560
 Test Item : Harmonic Radiated Emission Data
 Test Date : 2019/11/26
 Test Mode : Mode 1 SISO A: Transmit (802.11a_6Mbps) (5580MHz)

Vertical

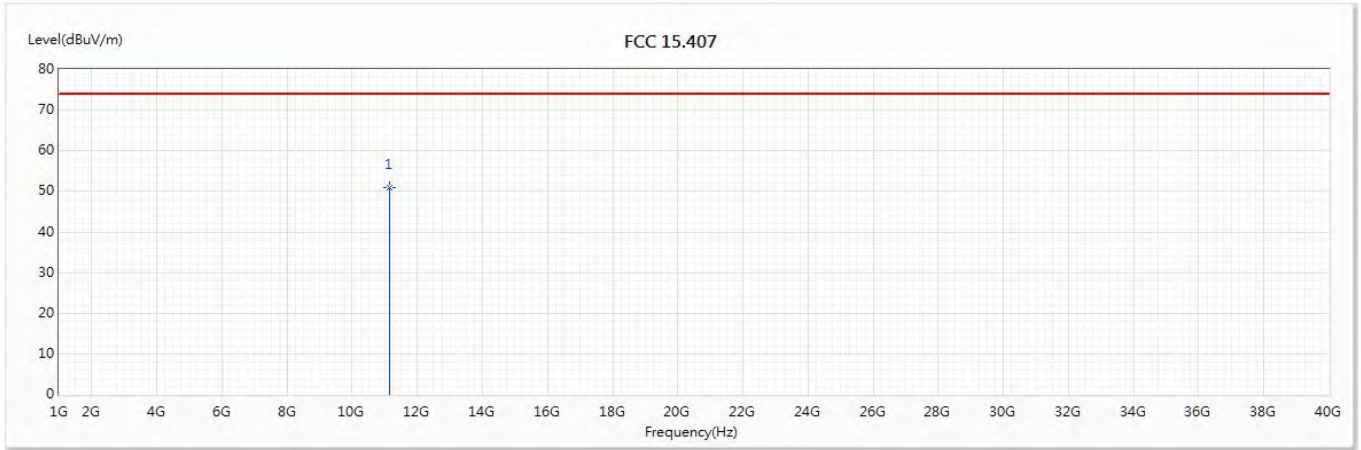

No	Frequency (MHz)	Emission Level (dBuV/m)	Limit (dBuV/m)	Margin (dB)	Reading Level (dBuV)	Correct Factor (dB/m)	Detector Type
* 1	11160	51.02	74.00	-22.98	47.38	3.64	PK

Note:

1. All Readings below 1GHz are Quasi-Peak, above 1GHz are performed with peak and/or average measurements as necessary.
2. Measurement Level = Reading Level + Correct Factor.
3. Correct Factor = Antenna factor + Cable loss – Amplifier gain.
4. The average measurement was not performed when the peak measured data under the limit of average detection.
5. The emission levels of other frequencies are very lower than the limit and not show in test report.

Product : Intel® Wireless-AC 9560
 Test Item : Harmonic Radiated Emission Data
 Test Date : 2019/11/26
 Test Mode : Mode 1 SISO A: Transmit (802.11a_6Mbps) (5700MHz)

Horizontal

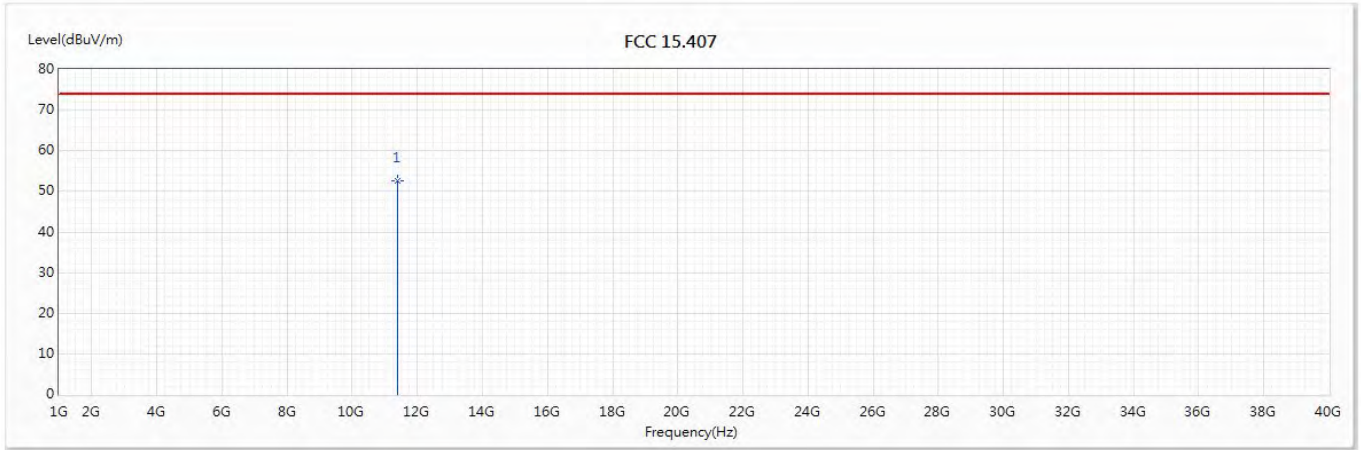

No	Frequency (MHz)	Emission Level (dBuV/m)	Limit (dBuV/m)	Margin (dB)	Reading Level (dBuV)	Correct Factor (dB/m)	Detector Type
* 1	11400	52.57	74.00	-21.43	48.36	4.21	PK

Note:

1. All Readings below 1GHz are Quasi-Peak, above 1GHz are performed with peak and/or average measurements as necessary.
2. Measurement Level = Reading Level + Correct Factor.
3. Correct Factor = Antenna factor + Cable loss – Amplifier gain.
4. The average measurement was not performed when the peak measured data under the limit of average detection.
5. The emission levels of other frequencies are very lower than the limit and not show in test report.

Product : Intel® Wireless-AC 9560
 Test Item : Harmonic Radiated Emission Data
 Test Date : 2019/11/26
 Test Mode : Mode 1 SISO A: Transmit (802.11a_6Mbps) (5700MHz)

Vertical

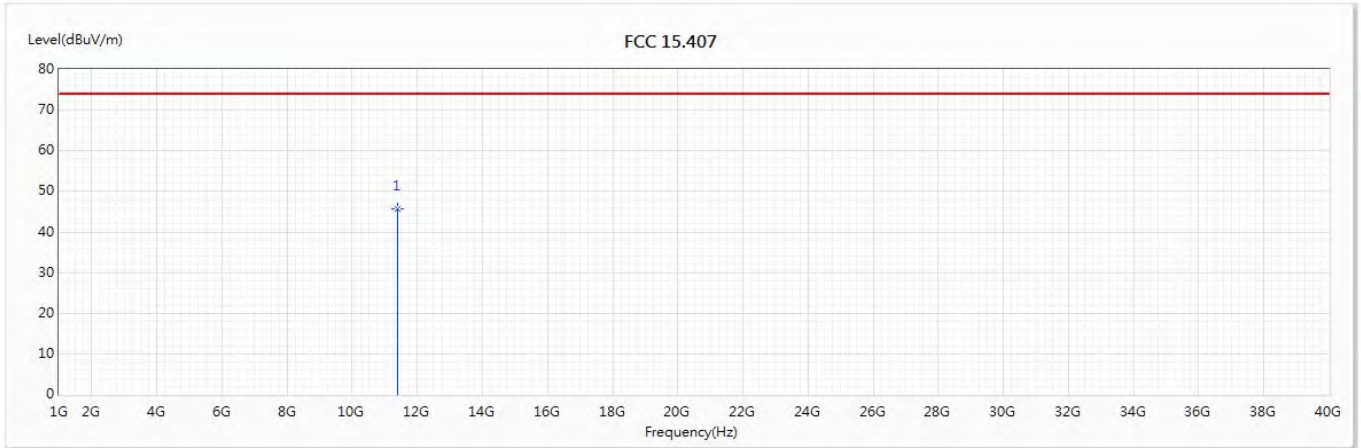

No	Frequency (MHz)	Emission Level (dBuV/m)	Limit (dBuV/m)	Margin (dB)	Reading Level (dBuV)	Correct Factor (dB/m)	Detector Type
* 1	11400	45.70	74.00	-28.30	41.49	4.21	PK

Note:

1. All Readings below 1GHz are Quasi-Peak, above 1GHz are performed with peak and/or average measurements as necessary.
2. Measurement Level = Reading Level + Correct Factor.
3. Correct Factor = Antenna factor + Cable loss – Amplifier gain.
4. The average measurement was not performed when the peak measured data under the limit of average detection.
5. The emission levels of other frequencies are very lower than the limit and not show in test report.

Product : Intel® Wireless-AC 9560
 Test Item : Harmonic Radiated Emission Data
 Test Date : 2019/11/26
 Test Mode : Mode 1 SISO A: Transmit (802.11a_6Mbps) (5745MHz)

Horizontal

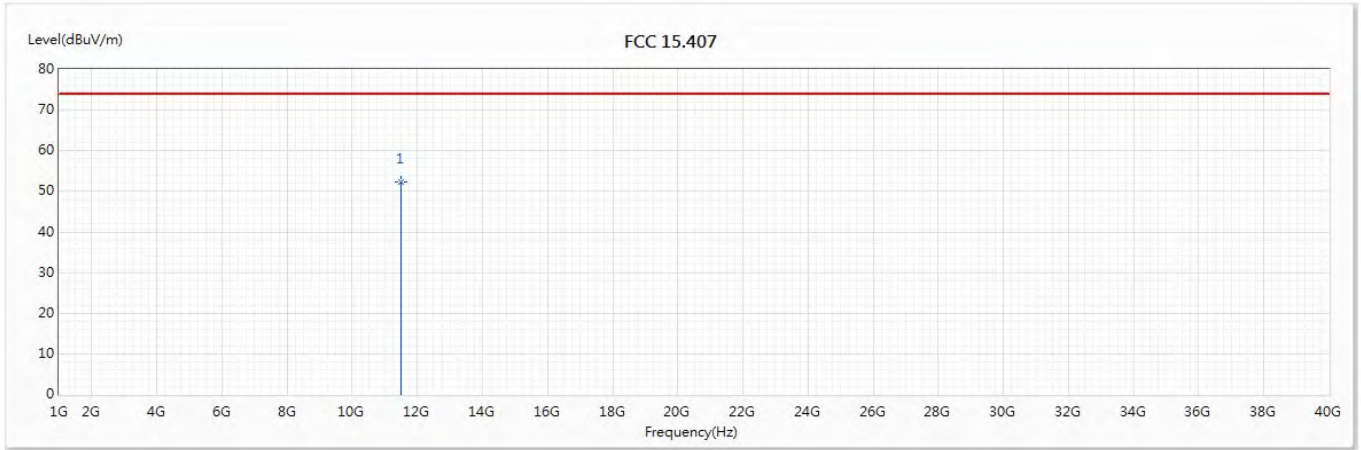

No	Frequency (MHz)	Emission Level (dBuV/m)	Limit (dBuV/m)	Margin (dB)	Reading Level (dBuV)	Correct Factor (dB/m)	Detector Type
* 1	11490	52.18	74.00	-21.82	47.75	4.43	PK

Note:

1. All Readings below 1GHz are Quasi-Peak, above 1GHz are performed with peak and/or average measurements as necessary.
2. Measurement Level = Reading Level + Correct Factor.
3. Correct Factor = Antenna factor + Cable loss – Amplifier gain.
4. The average measurement was not performed when the peak measured data under the limit of average detection.
5. The emission levels of other frequencies are very lower than the limit and not show in test report.

Product : Intel® Wireless-AC 9560
 Test Item : Harmonic Radiated Emission Data
 Test Date : 2019/11/26
 Test Mode : Mode 1 SISO A: Transmit (802.11a_6Mbps) (5745MHz)

Vertical

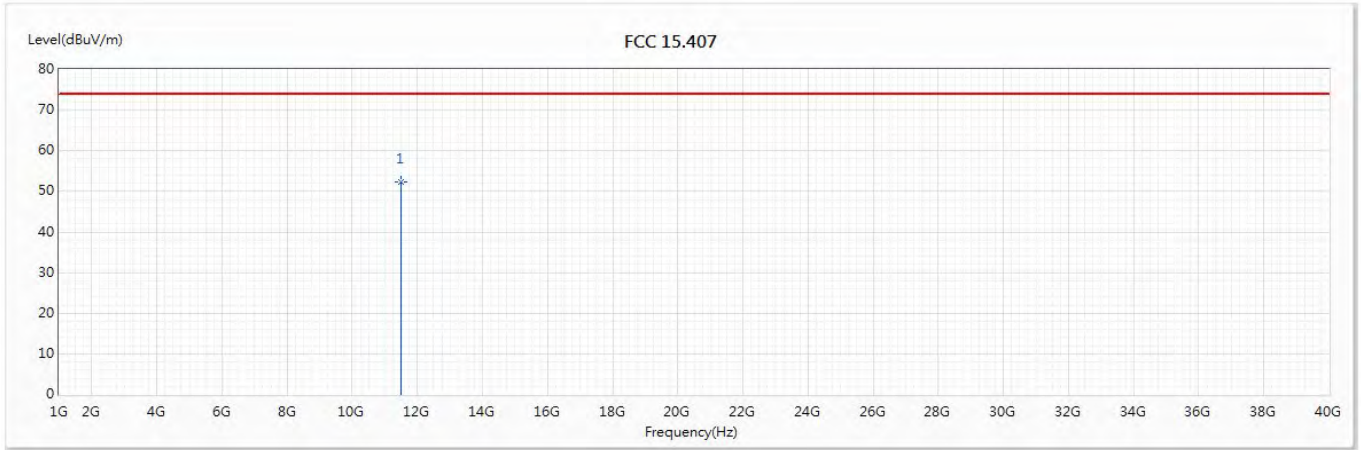

No	Frequency (MHz)	Emission Level (dBuV/m)	Limit (dBuV/m)	Margin (dB)	Reading Level (dBuV)	Correct Factor (dB/m)	Detector Type
* 1	11490	52.42	74.00	-21.58	47.99	4.43	PK

Note:

1. All Readings below 1GHz are Quasi-Peak, above 1GHz are performed with peak and/or average measurements as necessary.
2. Measurement Level = Reading Level + Correct Factor.
3. Correct Factor = Antenna factor + Cable loss – Amplifier gain.
4. The average measurement was not performed when the peak measured data under the limit of average detection.
5. The emission levels of other frequencies are very lower than the limit and not show in test report.

Product : Intel® Wireless-AC 9560
 Test Item : Harmonic Radiated Emission Data
 Test Date : 2019/11/26
 Test Mode : Mode 1 SISO A: Transmit (802.11a_6Mbps) (5785MHz)

Horizontal

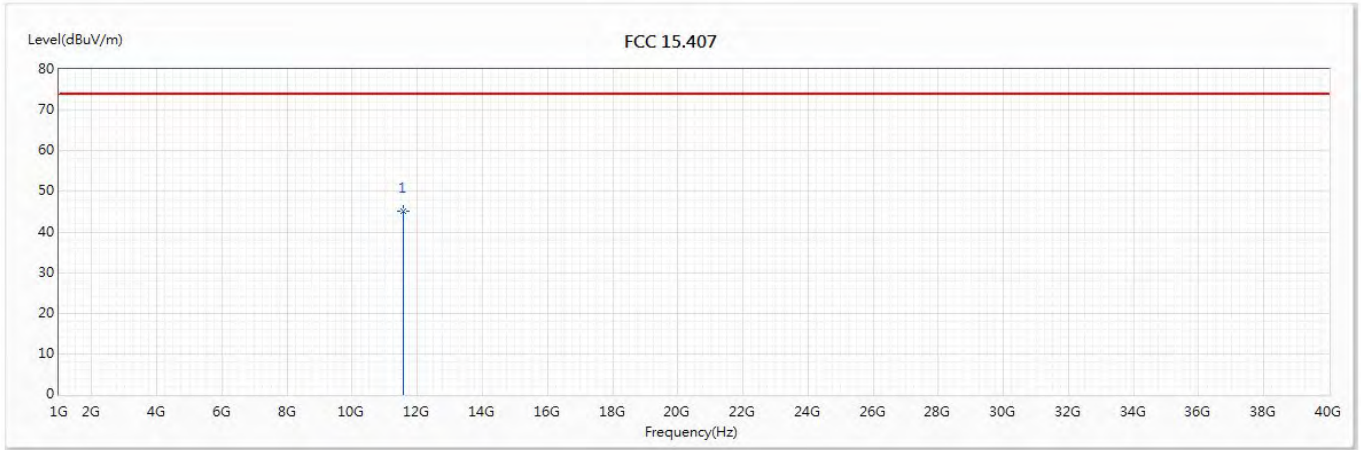

No	Frequency (MHz)	Emission Level (dBuV/m)	Limit (dBuV/m)	Margin (dB)	Reading Level (dBuV)	Correct Factor (dB/m)	Detector Type
* 1	11570	45.04	74.00	-28.96	40.41	4.63	PK

Note:

1. All Readings below 1GHz are Quasi-Peak, above 1GHz are performed with peak and/or average measurements as necessary.
2. Measurement Level = Reading Level + Correct Factor.
3. Correct Factor = Antenna factor + Cable loss – Amplifier gain.
4. The average measurement was not performed when the peak measured data under the limit of average detection.
5. The emission levels of other frequencies are very lower than the limit and not show in test report.

Product : Intel® Wireless-AC 9560
 Test Item : Harmonic Radiated Emission Data
 Test Date : 2019/11/26
 Test Mode : Mode 1 SISO A: Transmit (802.11a_6Mbps) (5785MHz)

Vertical

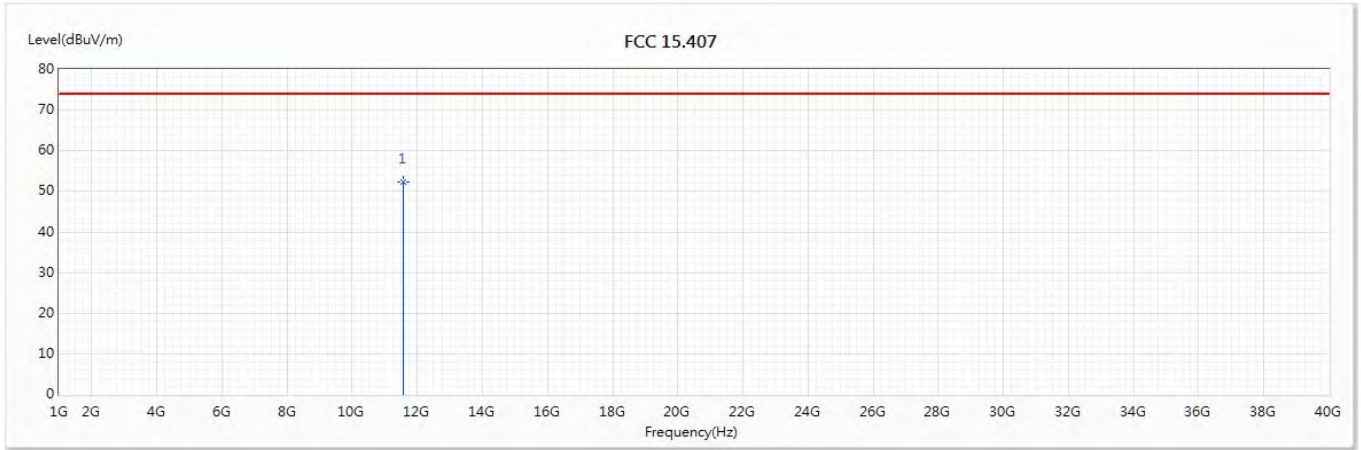

No	Frequency (MHz)	Emission Level (dBuV/m)	Limit (dBuV/m)	Margin (dB)	Reading Level (dBuV)	Correct Factor (dB/m)	Detector Type
* 1	11570	52.27	74.00	-21.73	47.64	4.63	PK

Note:

1. All Readings below 1GHz are Quasi-Peak, above 1GHz are performed with peak and/or average measurements as necessary.
2. Measurement Level = Reading Level + Correct Factor.
3. Correct Factor = Antenna factor + Cable loss – Amplifier gain.
4. The average measurement was not performed when the peak measured data under the limit of average detection.
5. The emission levels of other frequencies are very lower than the limit and not show in test report.

Product : Intel® Wireless-AC 9560
 Test Item : Harmonic Radiated Emission Data
 Test Date : 2019/11/26
 Test Mode : Mode 1 SISO A: Transmit (802.11a_6Mbps) (5825MHz)

Horizontal

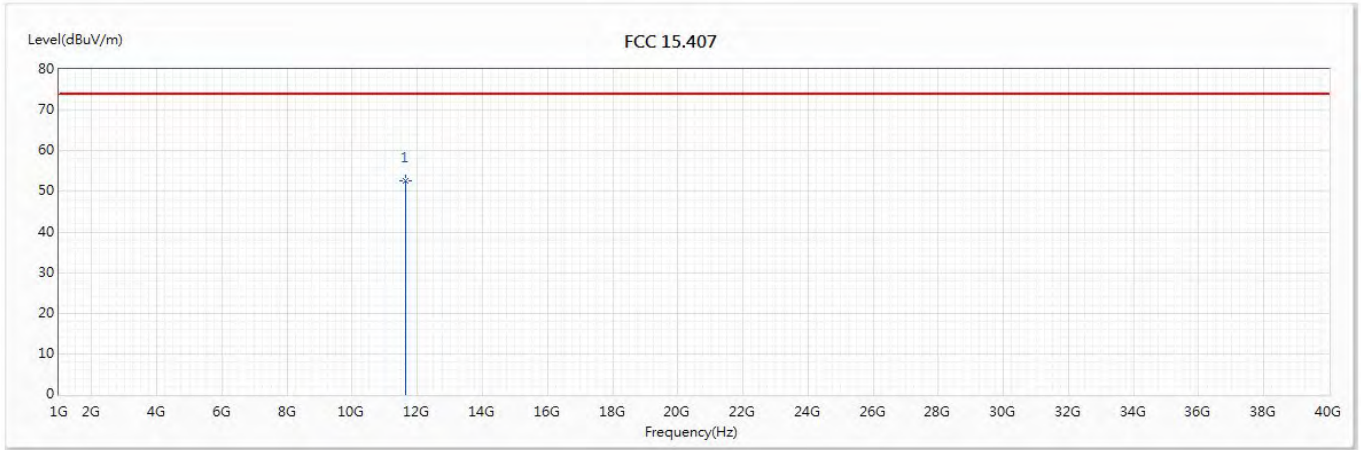

No	Frequency (MHz)	Emission Level (dBuV/m)	Limit (dBuV/m)	Margin (dB)	Reading Level (dBuV)	Correct Factor (dB/m)	Detector Type
* 1	11650	52.48	74.00	-21.52	47.91	4.57	PK

Note:

1. All Readings below 1GHz are Quasi-Peak, above 1GHz are performed with peak and/or average measurements as necessary.
2. Measurement Level = Reading Level + Correct Factor.
3. Correct Factor = Antenna factor + Cable loss – Amplifier gain.
4. The average measurement was not performed when the peak measured data under the limit of average detection.
5. The emission levels of other frequencies are very lower than the limit and not show in test report.

Product : Intel® Wireless-AC 9560
 Test Item : Harmonic Radiated Emission Data
 Test Date : 2019/11/26
 Test Mode : Mode 1 SISO A: Transmit (802.11a_6Mbps) (5825MHz)

Vertical

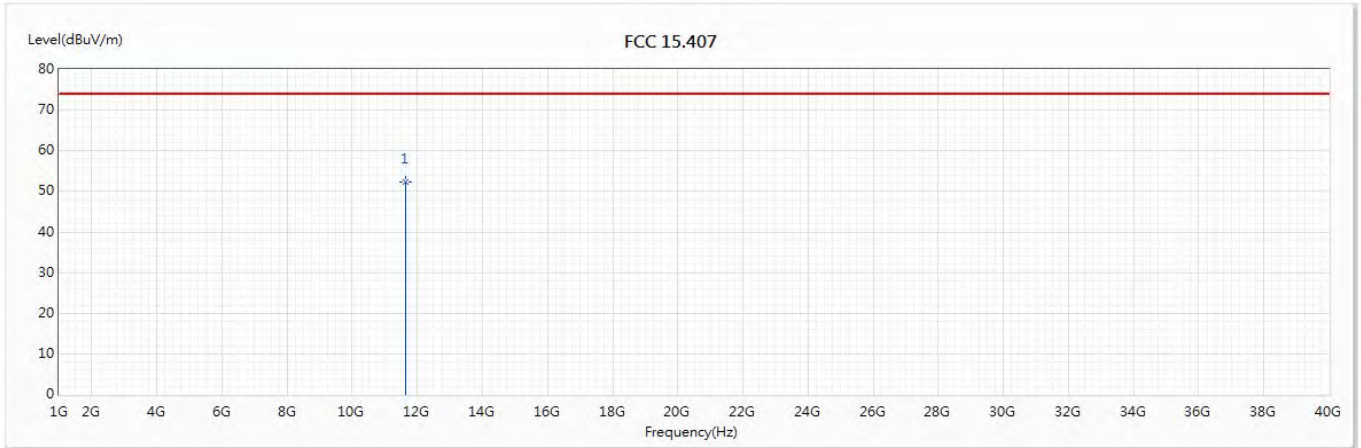

No	Frequency (MHz)	Emission Level (dBuV/m)	Limit (dBuV/m)	Margin (dB)	Reading Level (dBuV)	Correct Factor (dB/m)	Detector Type
* 1	11650	52.44	74.00	-21.56	47.87	4.57	PK

Note:

1. All Readings below 1GHz are Quasi-Peak, above 1GHz are performed with peak and/or average measurements as necessary.
2. Measurement Level = Reading Level + Correct Factor.
3. Correct Factor = Antenna factor + Cable loss – Amplifier gain.
4. The average measurement was not performed when the peak measured data under the limit of average detection.
5. The emission levels of other frequencies are very lower than the limit and not show in test report.

Product : Intel® Wireless-AC 9560
 Test Item : Harmonic Radiated Emission Data
 Test Date : 2019/12/05
 Test Mode : Mode 2 SISO A: Transmit (802.11n-20BW_7.2Mbps) (5180MHz)

Horizontal

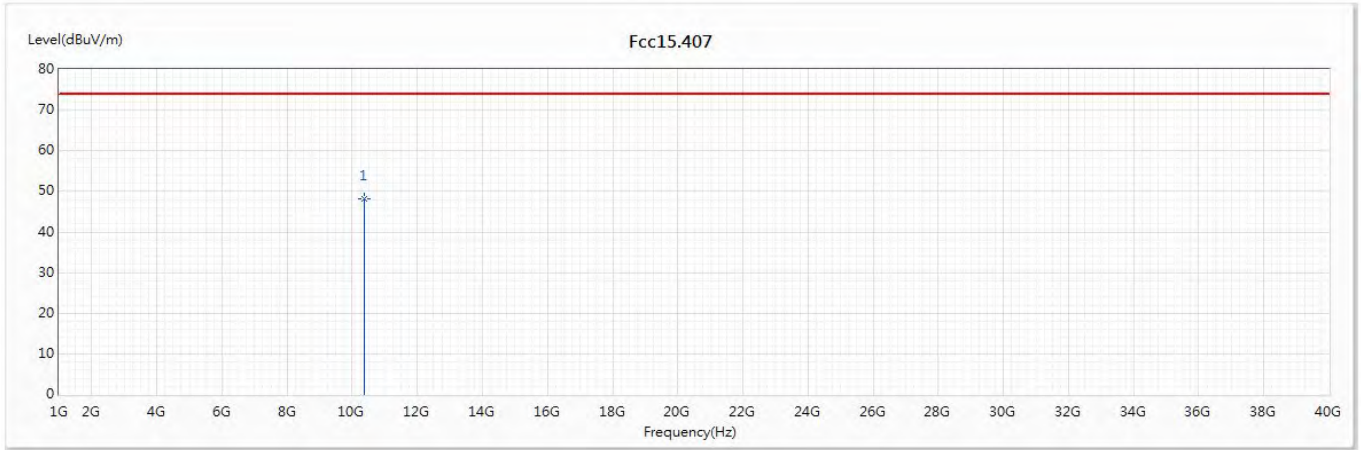

No	Frequency (MHz)	Emission Level (dBuV/m)	Limit (dBuV/m)	Margin (dB)	Reading Level (dBuV)	Correct Factor (dB/m)	Detector Type
* 1	10360	48.12	74.00	-25.88	45.53	2.59	PK

Note:

1. All Readings below 1GHz are Quasi-Peak, above 1GHz are performed with peak and/or average measurements as necessary.
2. Measurement Level = Reading Level + Correct Factor.
3. Correct Factor = Antenna factor + Cable loss – Amplifier gain.
4. The average measurement was not performed when the peak measured data under the limit of average detection.
5. The emission levels of other frequencies are very lower than the limit and not show in test report.

Product : Intel® Wireless-AC 9560
 Test Item : Harmonic Radiated Emission Data
 Test Date : 2019/12/05
 Test Mode : Mode 2 SISO A: Transmit (802.11n-20BW_7.2Mbps) (5180MHz)

Vertical

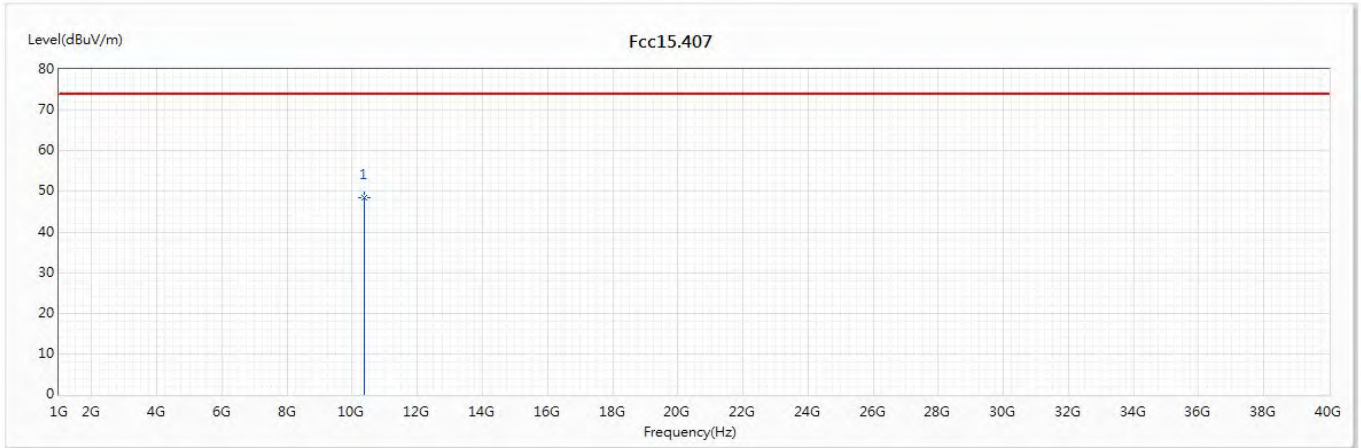

No	Frequency (MHz)	Emission Level (dBuV/m)	Limit (dBuV/m)	Margin (dB)	Reading Level (dBuV)	Correct Factor (dB/m)	Detector Type
* 1	10360	48.45	74.00	-25.55	45.86	2.59	PK

Note:

1. All Readings below 1GHz are Quasi-Peak, above 1GHz are performed with peak and/or average measurements as necessary.
2. Measurement Level = Reading Level + Correct Factor.
3. Correct Factor = Antenna factor + Cable loss – Amplifier gain.
4. The average measurement was not performed when the peak measured data under the limit of average detection.
5. The emission levels of other frequencies are very lower than the limit and not show in test report.

Product : Intel® Wireless-AC 9560
 Test Item : Harmonic Radiated Emission Data
 Test Date : 2019/12/05
 Test Mode : Mode 2 SISO A: Transmit (802.11n-20BW_7.2Mbps) (5220MHz)

Horizontal

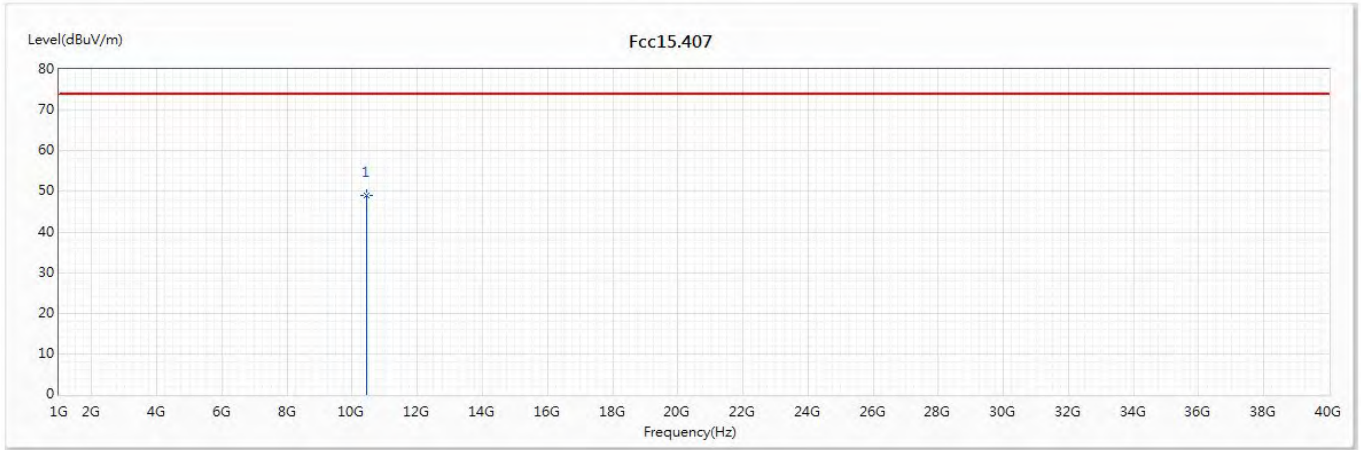

No	Frequency (MHz)	Emission Level (dBuV/m)	Limit (dBuV/m)	Margin (dB)	Reading Level (dBuV)	Correct Factor (dB/m)	Detector Type
* 1	10440	49.09	74.00	-24.91	46.23	2.86	PK

Note:

1. All Readings below 1GHz are Quasi-Peak, above 1GHz are performed with peak and/or average measurements as necessary.
2. Measurement Level = Reading Level + Correct Factor.
3. Correct Factor = Antenna factor + Cable loss – Amplifier gain.
4. The average measurement was not performed when the peak measured data under the limit of average detection.
5. The emission levels of other frequencies are very lower than the limit and not show in test report.

Product : Intel® Wireless-AC 9560
 Test Item : Harmonic Radiated Emission Data
 Test Date : 2019/12/05
 Test Mode : Mode 2 SISO A: Transmit (802.11n-20BW_7.2Mbps) (5220MHz)

Vertical

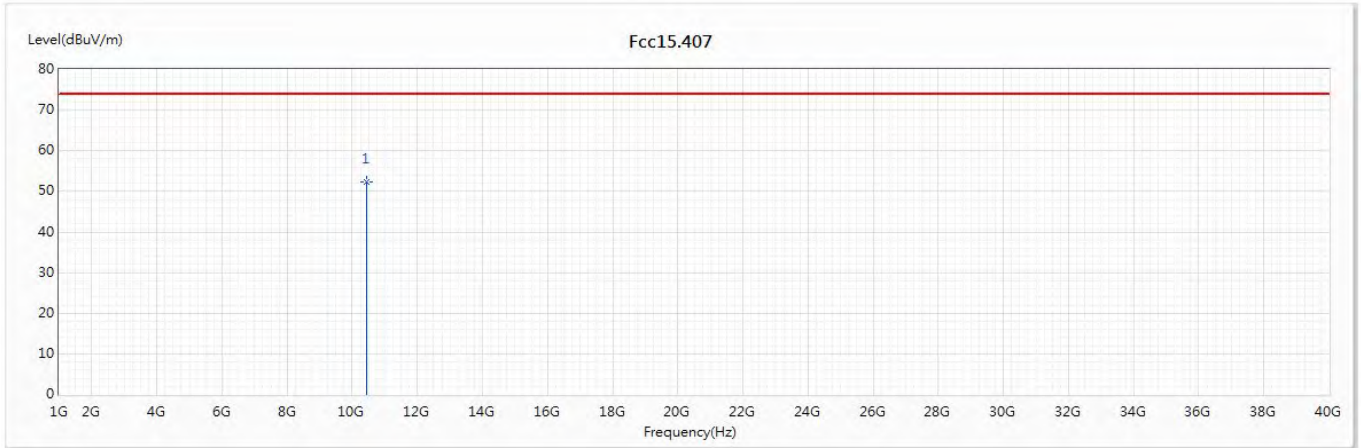

No	Frequency (MHz)	Emission Level (dBuV/m)	Limit (dBuV/m)	Margin (dB)	Reading Level (dBuV)	Correct Factor (dB/m)	Detector Type
* 1	10440	52.41	74.00	-21.59	49.55	2.86	PK

Note:

1. All Readings below 1GHz are Quasi-Peak, above 1GHz are performed with peak and/or average measurements as necessary.
2. Measurement Level = Reading Level + Correct Factor.
3. Correct Factor = Antenna factor + Cable loss – Amplifier gain.
4. The average measurement was not performed when the peak measured data under the limit of average detection.
5. The emission levels of other frequencies are very lower than the limit and not show in test report.

Product : Intel® Wireless-AC 9560
 Test Item : Harmonic Radiated Emission Data
 Test Date : 2019/12/05
 Test Mode : Mode 2 SISO A: Transmit (802.11n-20BW_7.2Mbps) (5240MHz)

Horizontal

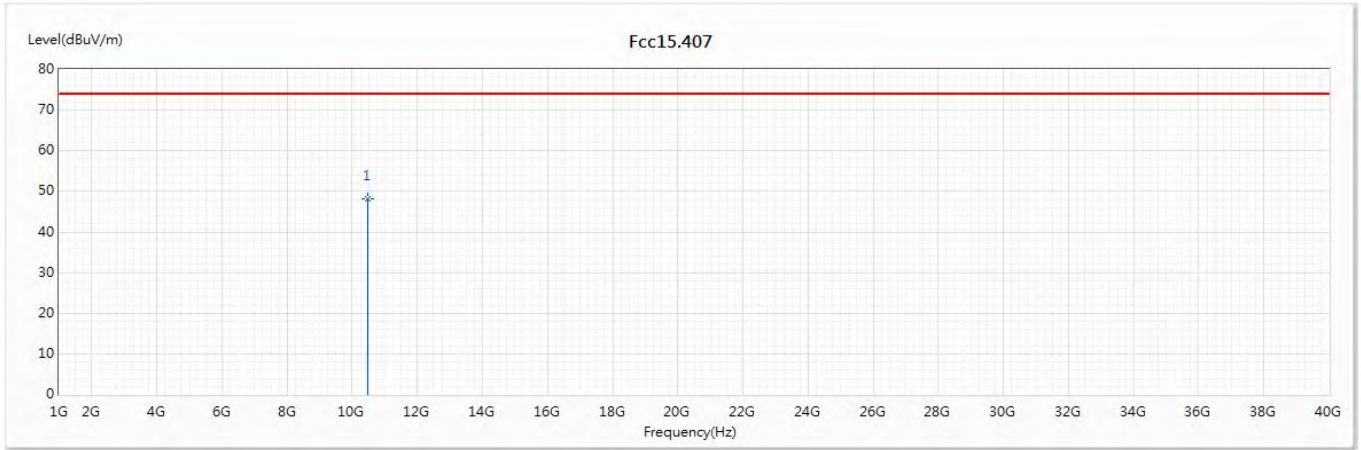

No	Frequency (MHz)	Emission Level (dBuV/m)	Limit (dBuV/m)	Margin (dB)	Reading Level (dBuV)	Correct Factor (dB/m)	Detector Type
* 1	10480	48.03	74.00	-25.97	45.22	2.81	PK

Note:

1. All Readings below 1GHz are Quasi-Peak, above 1GHz are performed with peak and/or average measurements as necessary.
2. Measurement Level = Reading Level + Correct Factor.
3. Correct Factor = Antenna factor + Cable loss –Amplifier gain.
4. The average measurement was not performed when the peak measured data under the limit of average detection.
5. The emission levels of other frequencies are very lower than the limit and not show in test report.

Product : Intel® Wireless-AC 9560
 Test Item : Harmonic Radiated Emission Data
 Test Date : 2019/12/05
 Test Mode : Mode 2 SISO A: Transmit (802.11n-20BW_7.2Mbps) (5240MHz)

Vertical

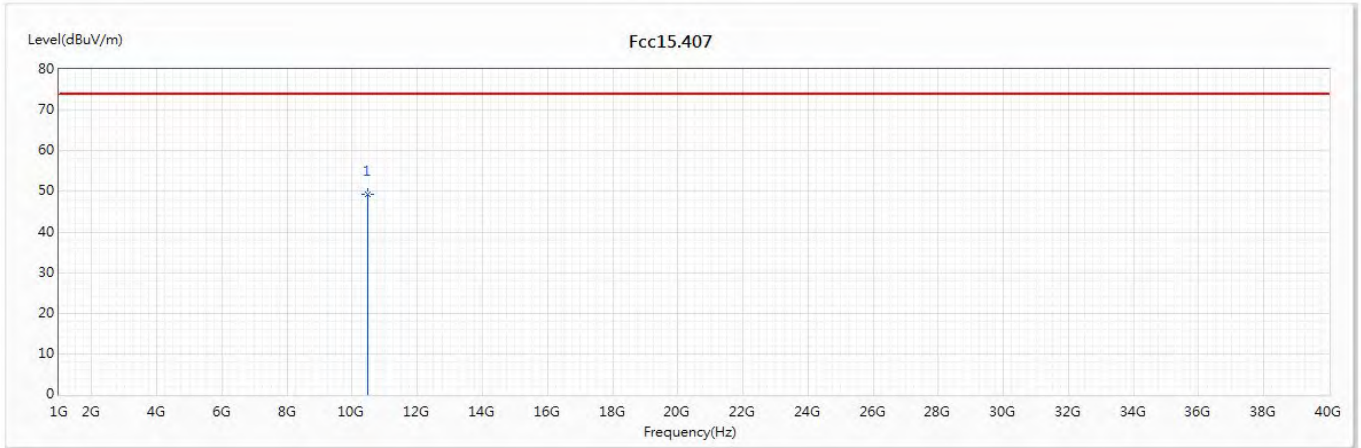

No	Frequency (MHz)	Emission Level (dBuV/m)	Limit (dBuV/m)	Margin (dB)	Reading Level (dBuV)	Correct Factor (dB/m)	Detector Type
* 1	10480	49.20	74.00	-24.80	46.39	2.81	PK

Note:

1. All Readings below 1GHz are Quasi-Peak, above 1GHz are performed with peak and/or average measurements as necessary.
2. Measurement Level = Reading Level + Correct Factor.
3. Correct Factor = Antenna factor + Cable loss – Amplifier gain.
4. The average measurement was not performed when the peak measured data under the limit of average detection.
5. The emission levels of other frequencies are very lower than the limit and not show in test report.

Product : Intel® Wireless-AC 9560
 Test Item : Harmonic Radiated Emission Data
 Test Date : 2019/12/05
 Test Mode : Mode 2 SISO A: Transmit (802.11n-20BW_7.2Mbps) (5260MHz)

Horizontal

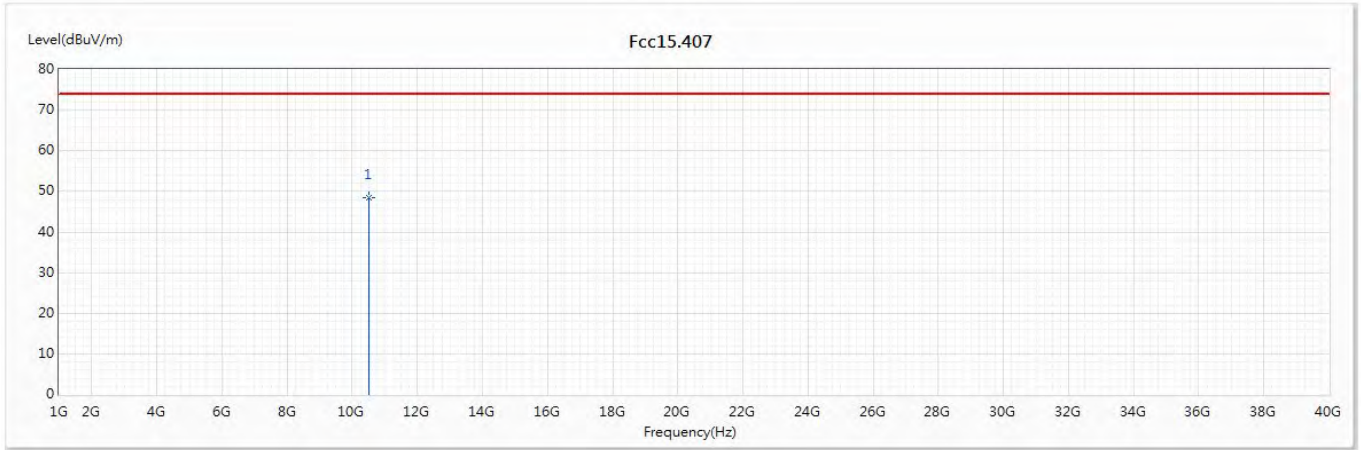

No	Frequency (MHz)	Emission Level (dBuV/m)	Limit (dBuV/m)	Margin (dB)	Reading Level (dBuV)	Correct Factor (dB/m)	Detector Type
* 1	10520	48.39	74.00	-25.61	45.78	2.61	PK

Note:

1. All Readings below 1GHz are Quasi-Peak, above 1GHz are performed with peak and/or average measurements as necessary.
2. Measurement Level = Reading Level + Correct Factor.
3. Correct Factor = Antenna factor + Cable loss – Amplifier gain.
4. The average measurement was not performed when the peak measured data under the limit of average detection.
5. The emission levels of other frequencies are very lower than the limit and not show in test report.