

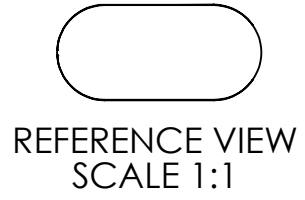

Code: DWG-0694
 Print Date: 07-Jul-2017
 Rev: 2
 Status: Current
 Effective Date: 01-Jun-2017
 Document valid for use on date of printing.

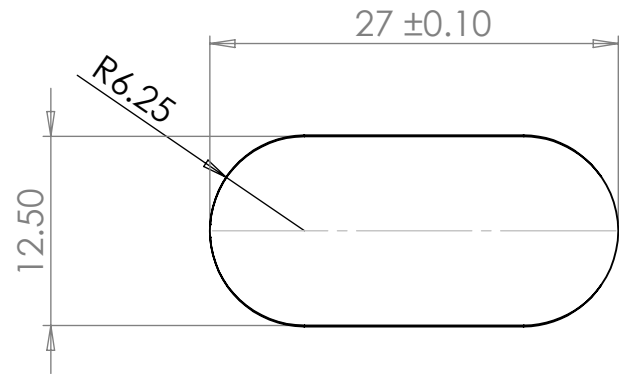

- | | |
|---|---|
|  | 1. SURFACE MATERIAL - POLYTHENE FILM, CODE BW9666 2. PRESSURE SENSITIVE ADHESIVE ACRYLIC LINER. GLASSINE RELEASE PAPER 3. BACKING PAPER. CODE OPP 4. LABEL THICKNESS. 0.13 ± 0.03mm 5. LABEL COLOUR: PANTONE 265C(PURPLE) 6. TEXT COLOUR: WHITE 7. ALL UNITS IN MILLIMETRES |
|---|---|

| | |
|--|-----|
| 1.LABEL COLOUR CHANGED TO PANTONE 265C(PURPLE) 2.TEXT COLOUR CHANGED TO WHITE REF ECR-2305 | 02 |
| FIRST RELEASE | 01 |
| MODIFICATION | REV |

IF IN DOUBT ASK
 EMAIL: DOC.CONTROL@SPDSPARK.COM
 TEL: +44 (0)1234 835000
 SPD DEVELOPMENT COMPANY LIMITED,
 CLEARBLUE INNOVATION CENTRE,
 PRIORY BUSINESS PARK, BEDFORD,
 MK44 3UP, UK

| | | |
|--|-----------|----------------------------|
| TOLERANCES OF LINEAR DIMENSIONS ISO 2768 (Fine) | | MATERIAL: SEE NOTES |
| UNLESS OTHERWISE STATED | | FINISH: N/A |
| DIMENSION | TOLERANCE | |
| 0 | -3 | WEIGHT: N/A |
| 3 | -6 | |
| 6 | -30 | |
| 30 | -120 | |
| 120 | -400 | |
| 400 | -1000 | |
| 1000 | -2000 | |
| 2000 | -4000 | |
| Angular Tolerance ±1.0° | | |

| | | |
|--|----------------------------|----------------------------|
| TITLE: <h2 style="margin: 0;">LIBERA LABEL</h2> | | |
| ENGINEERING NO: 12616 | DWG NO: DWG-0694 | DWG REVISION: 02 |
| PROJECT NUMBER: 0036 | | SHEET 1 OF 1 |