



# FCC RADIO TEST REPORT

Applicant : TRANSOUND ELECTRONICS CO.,LTD.  
Address : THE 3RD INDUSTRIAL ZONE SIJIA VILLAGE SHIJIE TOWN  
          : DONGGUAN CITY GUANGDONG  
Equipment : Bluetooth Headphone  
Model No. : TS-BT100  
Trademark : TRANSOUND  
FCC ID : 2AKDKTSBT100

**I HEREBY CERTIFY THAT :**

The sample was received on Oct. 28, 2016 and the testing was carried out on Nov. 13, 2016 at CerpPASS Technology Corp. The test result refers exclusively to the test presented test model / sample. Without written approval of CerpPASS Technology Corp., the test report shall not be reproduced except in full.

Approved by:

Ray Chou  
Assistant Manager

Laboratory Accreditation:

- CerpPASS Technology Corporation Test Laboratory

<b>NVLAP LAB Code:</b>	<b>200954-0</b>
<b>TAF LAB Code:</b>	<b>1439</b>
- CerpPASS Technology(SuZhou) Co., Ltd.

<b>NVLAP LAB Code:</b>	<b>200814-0</b>
<b>CNAS LAB Code:</b>	<b>L5515</b>



## Contents

<b>1. Report of Measurements and Examinations</b> .....	<b>5</b>
1.1 List of Measurements and Examinations.....	5
<b>2. Test Configuration of Equipment under Test</b> .....	<b>6</b>
2.1 Feature of Equipment under Test.....	6
2.2 Carrier Frequency of Channels.....	7
2.3 Test Mode & Test Software.....	8
2.4 Description of Test System.....	8
2.5 General Information of Test.....	9
2.6 Measurement Uncertainty.....	10
<b>3. Test Equipment and Ancillaries Used for Tests</b> .....	<b>11</b>
<b>4. Antenna Requirements</b> .....	<b>12</b>
4.1 Standard Applicable.....	12
4.2 Antenna Construction and Directional Gain.....	12
<b>5. Test of Conducted Emission</b> .....	<b>13</b>
5.1 Test Limit.....	13
5.2 Test Procedures.....	13
5.3 Typical Test Setup.....	14
5.4 Test Result and Data.....	15
<b>6. Test of Radiated Emission</b> .....	<b>17</b>
6.1 Test Limit.....	17
6.2 Test Procedures.....	18
6.3 Typical Test Setup.....	18
6.4 Test Result and Data.....	20
<b>7. 20dB Bandwidth Measurement Data</b> .....	<b>40</b>
7.1 Test Limit.....	40
7.2 Test Procedures.....	40
7.3 Test Setup Layout.....	40
7.4 Test Result and Data.....	40
<b>8. Frequencies Separation</b> .....	<b>46</b>
8.1 Test Limit.....	46
8.2 Test Procedures.....	46
8.3 Test Setup Layout.....	46
8.4 Test Result and Data.....	46
<b>9. Dwell Time on each channel</b> .....	<b>49</b>
9.1 Test Limit.....	49
9.2 Test Procedures.....	49
9.3 Test Setup Layout.....	49
9.4 Test Result and Data.....	50
<b>10. Number of Hopping Channels</b> .....	<b>57</b>
10.1 Test Limit.....	57
10.2 Test Procedures.....	57
10.3 Test Setup Layout.....	57



---

10.4	Test Result and Data.....	57
<b>11.</b>	<b>Maximum Peak Output Power .....</b>	<b>60</b>
11.1	Test Limit .....	60
11.2	Test Procedures .....	60
11.3	Test Setup Layout .....	60
11.4	Test Result and Data.....	60
<b>12.</b>	<b>Band Edges Measurement.....</b>	<b>66</b>
12.1	Test Limit .....	66
12.2	Test Procedure .....	66
12.3	Test Setup Layout .....	66
12.4	Test Result and Data.....	67
12.5	Restrict band emission Measurement Data.....	70
<b>13.</b>	<b>Restricted Bands of Operation .....</b>	<b>82</b>
13.1	Labeling Requirement.....	82



History of this test report

ORIGINAL

Additional attachment as following record:

Attachment No.	Issue Date	Description



# 1. Report of Measurements and Examinations

## 1.1 List of Measurements and Examinations

FCC Rule	Description of Test	Result
§ 15.203	. Antenna Requirement	Pass
§ 15.207(a)	. Conducted Emission	Pass
§ 15.209(a)	. Radiated Emission	Pass
§ 15.247(a)(1)	. Channel Carrier Frequencies Separation	Pass
§ 15.247(a)(1)	. 20dB Bandwidth Measurement	Pass
§ 15.247(a)(1)	. Dwell Time	Pass
§ 15.247(b)	. Number of Hopping Channels	Pass
§ 15.247(b)	. Peak Output Power Measurement Data	Pass
§ 15.247(d)	. Band Edges Measurement Data	Pass



## 2. Test Configuration of Equipment under Test

### 2.1 Feature of Equipment under Test

<b>Product Name:</b>	Bluetooth Headphone
<b>Model Name:</b>	TS-BT100
<b>Series Model:</b>	N/A
<b>Model Discrepancy:</b>	N/A
<b>Frequency</b>	2.402GHz~2.480GHz
<b>Number of Channel</b>	79 channel
<b>Modulation type</b>	GFSK, $\pi/4$ DQPSK, 8DPSK
<b>Transmit Power</b>	GFSK: 7.538dBm
	$\pi/4$ DQPSK: 7.070dBm
	8DPSK : 7.230dBm
<b>Antenna type</b>	FPCB antenna with -0.61dBi
<b>EUT Power Rating:</b>	DC 3.7V supplied by Battery Charge with DC 5V
<b>Adapter Spec.:</b>	N/A

Note: 1. For a more detailed features description, please refer to the manufacturer's specifications or the User's Manual.



## 2.2 Carrier Frequency of Channels

Channel	Frequency (MHz)	Channel	Frequency (MHz)	Channel	Frequency (MHz)	Channel	Frequency (MHz)
00	2402	20	2422	40	2442	60	2462
01	2403	21	2423	41	2443	61	2463
02	2404	22	2424	42	2444	62	2464
03	2405	23	2425	43	2445	63	2465
04	2406	24	2426	44	2446	64	2466
05	2407	25	2427	45	2447	65	2467
06	2408	26	2428	46	2448	66	2468
07	2409	27	2429	47	2449	67	2469
08	2410	28	2430	48	2450	68	2470
09	2411	29	2431	49	2451	69	2471
10	2412	30	2432	50	2452	70	2472
11	2413	31	2433	51	2453	71	2473
12	2414	32	2434	52	2454	72	2474
13	2415	33	2435	53	2455	73	2475
14	2416	34	2436	54	2456	74	2476
15	2417	35	2437	55	2457	75	2477
16	2418	36	2438	56	2458	76	2478
17	2419	37	2439	57	2459	77	2479
18	2420	38	2440	58	2460	78	2480
19	2421	39	2441	59	2461	---	---



### 2.3 Test Mode & Test Software

- a. During testing, the interface cables and equipment positions were varied according to ANSI C63.10
- b. The complete test system included EUT, Notebook, USB Mouse for RF test.
- c. Run the test software “CSR BlueTest3”, input RF test command and set the test mode and channel, then press OK to start continue transmit.
- d. The following test mode was performed for conduction and radiation test:
  - Test Mode 1: GFSK: CH 00: 2402MHz, CH 39: 2441MHz, CH 78: 2480MHz.
  - Test Mode 2:  $\pi/4$  DQPSK : CH 00: 2402MHz, CH 39: 2441MHz, CH 78: 2480MHz.
  - Test Mode 3: 8DPSK: CH 00: 2402MHz, CH 39: 2441MHz, CH 78: 2480MHz.

### 2.4 Description of Test System

No	Device	Manufacturer	Model No.	Description
1	Notebook	SONY	PCG-71811P	R33021
2	USB Mouse	DELL	OXN967	R41108





## 2.5 General Information of Test

<input checked="" type="checkbox"/>	Test Site	<b>CerpPASS Technology Corporation Test Laboratory</b> Address: No.10, Ln. 2, Lianfu St., Luzhu Dist., Taoyuan City 33848, Taiwan (R.O.C.) Tel:+886-3-3226-888 Fax:+886-3-3226-881 Address: No.68-1, Shihbachongsi, Shihding Township, New Taipei City 223, Taiwan, R.O.C. Tel: +886-2-2663-8582
	FCC	TW1079, TW1061,390316, 228391, 641184
	IC	4934B-1, 4934E-1, 4934E-2
	VCCI	T-2205 for Telecommunication Test C-4663 for Conducted emission test R-3428, R-4218 for Radiated emission test G-812, G-813 for radiated disturbance above 1GHz
<input type="checkbox"/>	Test Site	<b>CerpPASS Technology (Suzhou) Co.,Ltd</b> Address: No.66,Tangzhuang Road, Suzhou Industrial Park, Jiangsu 215006, China Tel: +86-512-6917-5888 Fax: +86-512-6917-5666
	FCC	916572, 331395
	IC	7290A-1, 7290A-2
	VCCI	T-343 for Telecommunication Test C-2919 for Conducted emission test R-2670 for Radiated emission test G-227 for radiated disturbance above 1GHz
Frequency Range Investigated:		Conducted: from 150kHz to 30 MHz Radiation: from 30 MHz to 25000MHz
Test Distance:		The test distance of radiated emission from antenna to EUT is 3 M.



## 2.6 Measurement Uncertainty

Measurement Item	Measurement Uncertainty
Conducted Emission	$\pm 2.71$ dB
Radiation test (10m) below 1GHz	Vertical : $\pm 3.89$ dB
	Horizontal: $\pm 4.11$ dB
Radiation test (3m) below 1GHz	Vertical : $\pm 4.11$ dB
	Horizontal: $\pm 4.10$ dB
20 dB Bandwidth	7500 Hz
Maximum Peak Output Power	$\pm 1.4$ dB
100kHz Bandwidth of Frequency Band Edges	$\pm 2.2$ dB
Power Spectral Density	$\pm 1.3870$ dB



### 3. Test Equipment and Ancillaries Used for Tests

Instrument	Manufacturer	Model No.	Serial No.	Calibration Date	Valid Date
Test Receiver	R&S	ESCI	100564	2016.02.22	2017.02.21
LISN	SCHWARZBECK	NSLK 8127	8127748	2016.03.28	2017.03.27
LISN	SCHWARZBECK	NSLK 8127	8127749	2016.03.28	2017.03.27
Pulse Limiter with 10dB Attenuation	SCHWARZBECK	VTSD 9561-F	9561-F106	2016.02.22	2017.02.21
Temperature/ Humidity Meter	mingle	ETH529	N/A	2016.02.22	2017.02.21
AMPLIFIER	HP	8447F	3113A05915	2016.02.22	2017.02.21
Loop Antenna	R&S	HFH2-Z2	100150	2016.04.16	2017.04.15
BILOG Antenna	SCHAFFNER	CBL6112D	22241	2016.02.24	2017.02.23
Horn Antenna	Sunol	DRH-118	A072913	2016.10.12	2017.10.11
Broad-Band Horn Antenna	Schwarzbeck	BBHA9170	9170-347	2016.04.16	2017.04.15
Preamplifier	COM-POWER	PA-840	711885	2016.03.26	2017.03.25
Temp&Humidity&barometer	mingle	ETH529	N/A	2016.02.19	2017.02.18
Preamplifier	Fleld	AFS44-0010180 0-25- 10P-44	1579008	2016.09.30	2017.09.29
ESG VECTOR SIGNAL GENERATOR	Agilent	E4438C	MY4509258 2	2016.06.06	2017.06.05
MXG VECTOR SIGNAL GENERATOR	Agilent	N5182B	MY5305012 7	2016.06.06	2017.06.05
EXA Signal Analyzer	Agilent	N9020A	US46220290	2016.06.06	2017.06.05
Power sensor	e-channel	ERS-180T-24	TW5451026	2016.06.25	2017.06.24
Series Power Meter	ANRITSU	ML24958A	1224005	2016.03.27	2017.03.26



## 4. Antenna Requirements

### 4.1 Standard Applicable

For intentional device, according to FCC 47 CFR Section 15.203, an intentional radiator shall be designed to ensure that no antenna other than that furnished by the responsible party shall be used with the device.

And according to FCC 47 CFR Section 15.247 (b), if transmitting antennas of directional gain greater than 6dBi are used, the power shall be reduced by the amount in dB that the directional gain of the antenna exceeds 6dBi.

### 4.2 Antenna Construction and Directional Gain

Antenna type: FPCB antenna

Antenna Gain: -0.61dBi



## 5. Test of Conducted Emission

### 5.1 Test Limit

Conducted Emissions were measured from 150 kHz to 30 MHz with a bandwidth of 9 KHz on the 120 VAC power and return leads of the EUT according to the methods defined in ANSI C63.10-2013. The EUT was placed on a nonmetallic stand in a shielded room 0.8 meters above the ground plane as shown in section 6.2.2. The interface cables and equipment positioning were varied within limits of reasonable applications to determine the position produced maximum conducted emissions

Frequency (MHz)	Quasi Peak (dB $\mu$ V)	Average (dB $\mu$ V)
0.15 – 0.5	66-56*	56-46*
0.5 – 5.0	56	46
5.0 – 30.0	60	50

\*Decreases with the logarithm of the frequency.

### 5.2 Test Procedures

- a. The EUT was placed 0.4 meter from the conducting wall of the shielding room was kept at least 80 centimeters from any other grounded conducting surface.
- b. Connect EUT to the power mains through a line impedance stabilization network (LISN).
- c. All the support units are connecting to the other LISN.
- d. The LISN provides 50 ohm coupling impedance for the measuring instrument.
- e. The FCC states that a 50 ohm, 50 micro-Henry LISN should be used.
- f. Both sides of AC line were checked for maximum conducted interference.
- g. The frequency range from 150 kHz to 30 MHz was searched.
- h. Set the test-receiver system to Peak Detect Function and Specified Bandwidth with Maximum Hold Mode.



### 5.3 Typical Test Setup

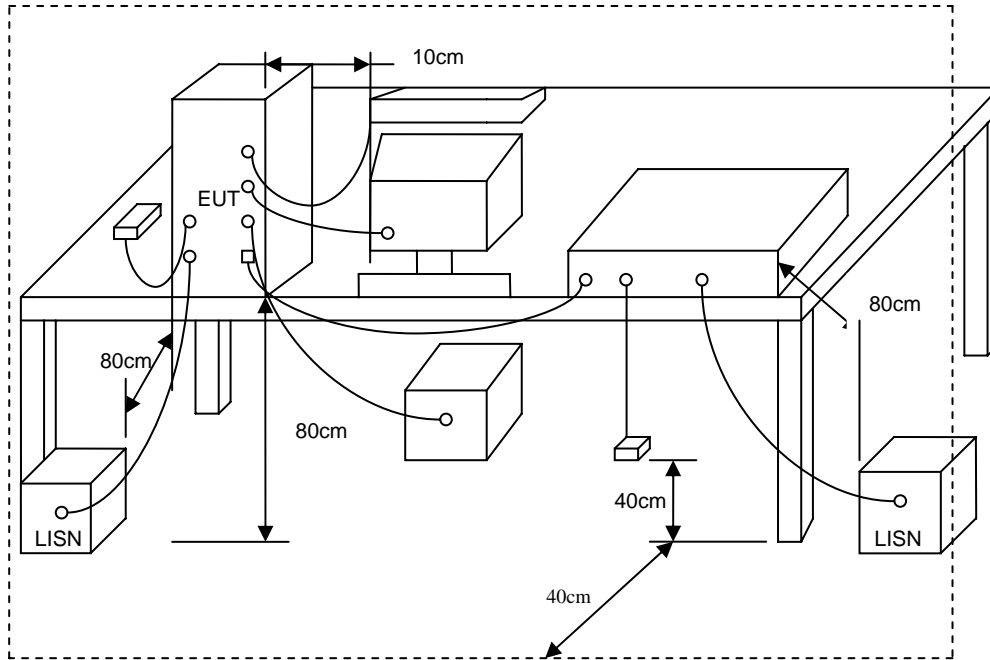



### 5.4 Test Result and Data

Test Mode :	Normal Link	Phase :	Line
Temperature :	20°C	Humidity:	51%
Pressur(mbar) :	1002	Date:	2016/11/13

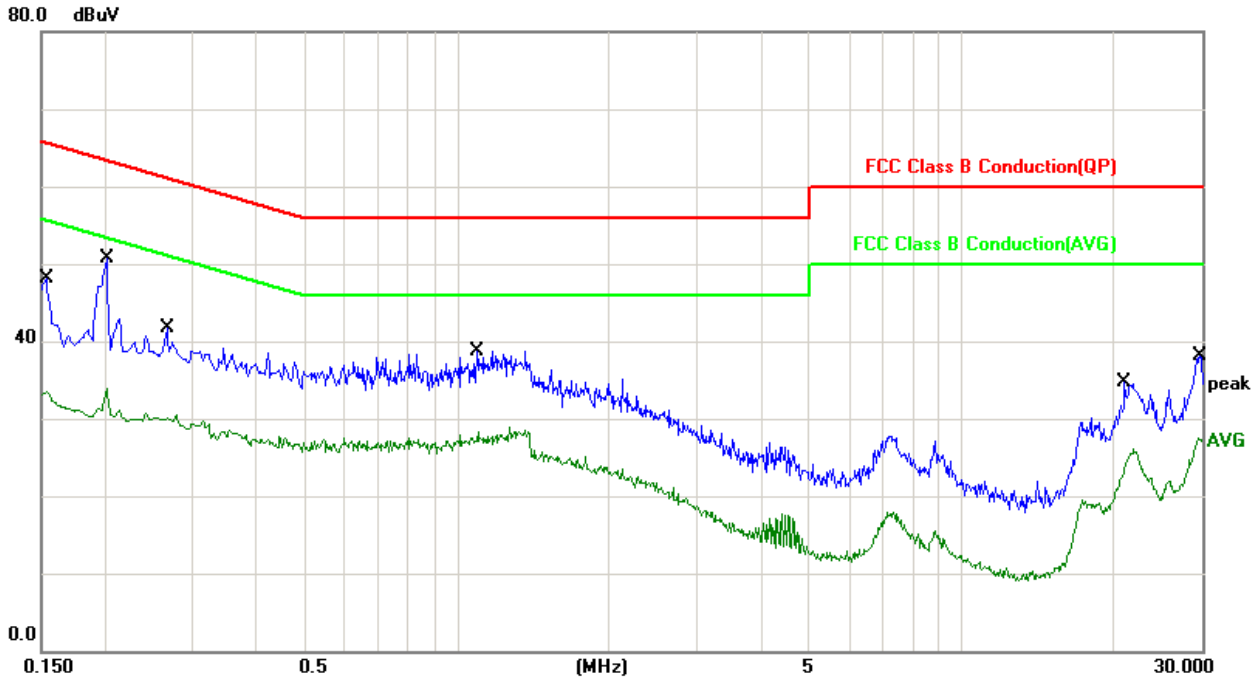

No.	Frequency (MHz)	Factor (dB)	Reading (dBuV)	Level (dBuV)	Limit (dBuV)	Margin (dB)	Detector
1	0.1539	10.06	46.91	56.97	65.78	-8.81	QP
2	0.1539	10.06	25.53	35.59	55.78	-20.19	AVG
3	0.2020	10.06	35.15	45.21	63.52	-18.31	QP
4	0.2020	10.06	21.41	31.47	53.52	-22.05	AVG
5	0.2660	10.02	24.98	35.00	61.24	-26.24	QP
6	0.2660	10.02	19.57	29.59	51.24	-21.65	AVG
7	1.0940	10.21	21.86	32.07	56.00	-23.93	QP
8	1.0940	10.21	16.75	26.96	46.00	-19.04	AVG
9	21.0660	10.57	16.95	27.52	60.00	-32.48	QP
10	21.0660	10.57	12.02	22.59	50.00	-27.41	AVG
11	29.6860	10.64	21.40	32.04	60.00	-27.96	QP
12	29.6860	10.64	16.12	26.76	50.00	-23.24	AVG

Note: Measurement Level = Reading Level + Correct Factor+ Attenuator



Test Mode :	Normal Link	Phase :	Neutral
Temperature :	20°C	Humidity :	51%
Pressur(mbar) :	1002	Date :	2016/11/13

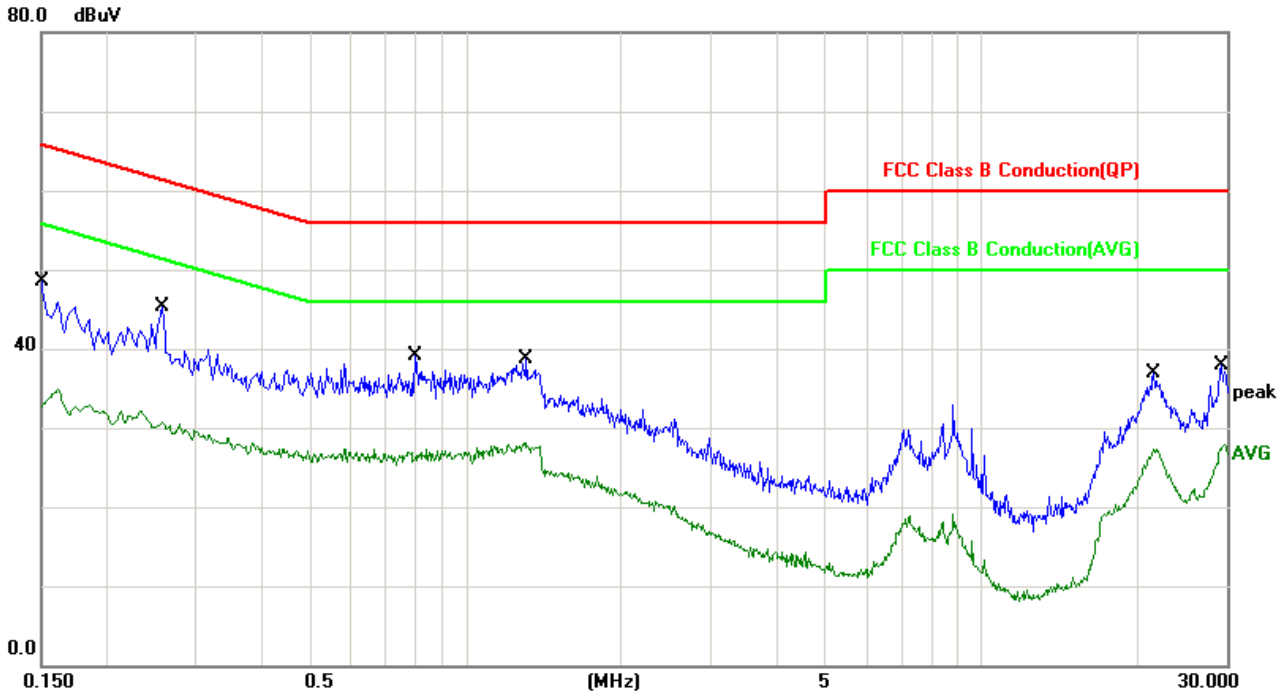

No.	Frequency (MHz)	Factor (dB)	Reading (dBuV)	Level (dBuV)	Limit (dBuV)	Margin (dB)	Detector
1	0.1500	10.06	45.56	55.62	65.99	-10.37	QP
2	0.1500	10.06	24.81	34.87	55.99	-21.12	AVG
3	0.2580	10.03	27.43	37.46	61.49	-24.03	QP
4	0.2580	10.03	20.05	30.08	51.49	-21.41	AVG
5	0.7980	10.09	21.67	31.76	56.00	-24.24	QP
6	0.7980	10.09	16.33	26.42	46.00	-19.58	AVG
7	1.3140	10.14	22.28	32.42	56.00	-23.58	QP
8	1.3140	10.14	17.09	27.23	46.00	-18.77	AVG
9	21.6980	10.57	20.90	31.47	60.00	-28.53	QP
10	21.6980	10.57	16.13	26.70	50.00	-23.30	AVG
11	29.3420	10.64	21.07	31.71	60.00	-28.29	QP
12	29.3420	10.64	15.92	26.56	50.00	-23.44	AVG

Note: Measurement Level = Reading Level + Correct Factor+ Attenuator





## 6. Test of Radiated Emission

### 6.1 Test Limit

In any 100kHz bandwidth outside the frequency band in which the spread spectrum or digitally modulated intentional radiator is operating, the radio frequency power that is produced by the intentional radiator shall be at least 20dB below that in the 100kHz bandwidth within the band that contains the highest level of the desired power, based on either an RF conducted or a radiated measurement. If the transmitter measurement is based on the maximum conducted output power, the attenuation required under this paragraph shall be 30dB instead of 20dB. In addition, radiated emissions which fall in section 15.205(a) the restricted bands must also comply with the radiated emission limit specified in section 15.209(a).

FREQUENCIES(MHz)	FIELD STRENGTH(microvolts/meter)	MEASUREMENT DISTANCE(meters)
0.009~0.490	2400/F(kHz)	300
0.490~1.705	24000/F(kHz)	30
1.705~30.0	30	30
30~88	100	3
88~216	150	3
216~960	200	3
Above 960	500	3

For unintentional device, according to CISPR PUB.22, for Class B digital devices, the general requirement of field strength of radiated emissions from intentional radiators at a distance of 10 meters shall not exceed the above table.

Frequency (MHz)	Distance Meters	Radiated (dB $\mu$ V/ M)
30-230	10	30
230-1000	10	37



## 6.2 Test Procedures

- a. The EUT was placed on a rotatable table top 0.8 meter above ground; above 1GHz, the height was 1.5m.
- b. The EUT was set 3 meters from the interference receiving antenna which was mounted on the top of a variable height antenna tower.
- c. The table was rotated 360 degrees to determine the position of the highest radiation.
- d. The antenna is a broadband antenna and its height is varied between one meter and four meters above ground to find the maximum value of the field strength both horizontal polarization and vertical polarization of the antenna are set to make the measurement.
- e. For each suspected emission the EUT was arranged to its worst case and then tune the antenna tower (from 1 M to 4 M) and turn table (from 0 degree to 360 degrees) to find the maximum reading.
- f. Set the test-receiver system to Peak or CISPR quasi-peak Detect Function and specified bandwidth with Maximum Hold Mode.
- g. If the emission level of the EUT in peak mode was 3 dB lower than the limit specified, then testing will be stopped and peak values of EUT will be reported, otherwise, the emissions which do not have 3 dB margin will be repeated one by one using the quasi-peak method and reported.
- h. For testing above 1GHz, the emission level of the EUT in peak mode was 20dB lower than average limit (that means the emission level in peak mode also complies with the limit in average mode), then testing will be stopped and peak values of EUT will be reported, otherwise, the emissions will be measured in average mode again and reported.

## 6.3 Typical Test Setup

### Below 1GHz Test Setup

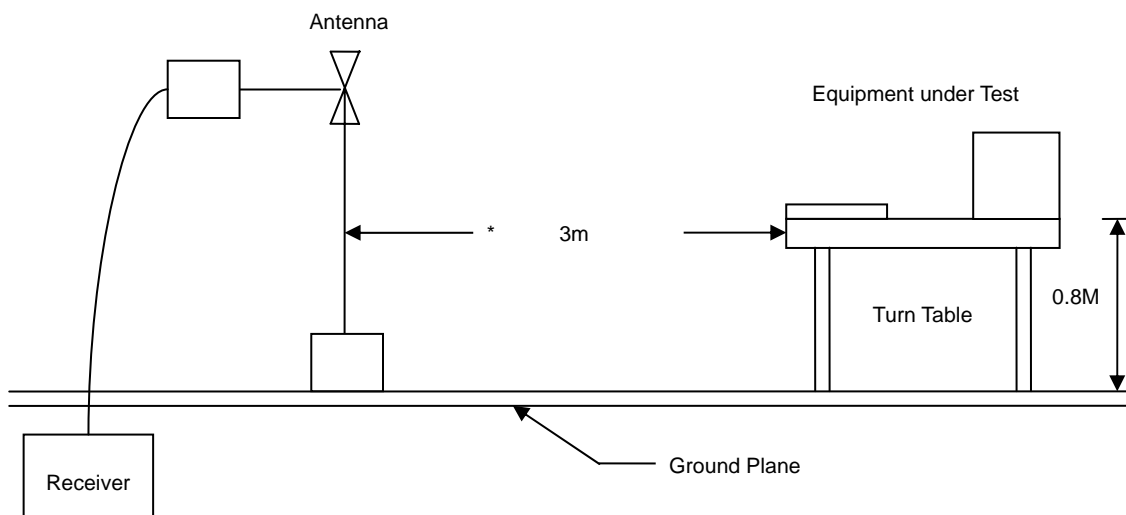



Above 1GHz Test Setup

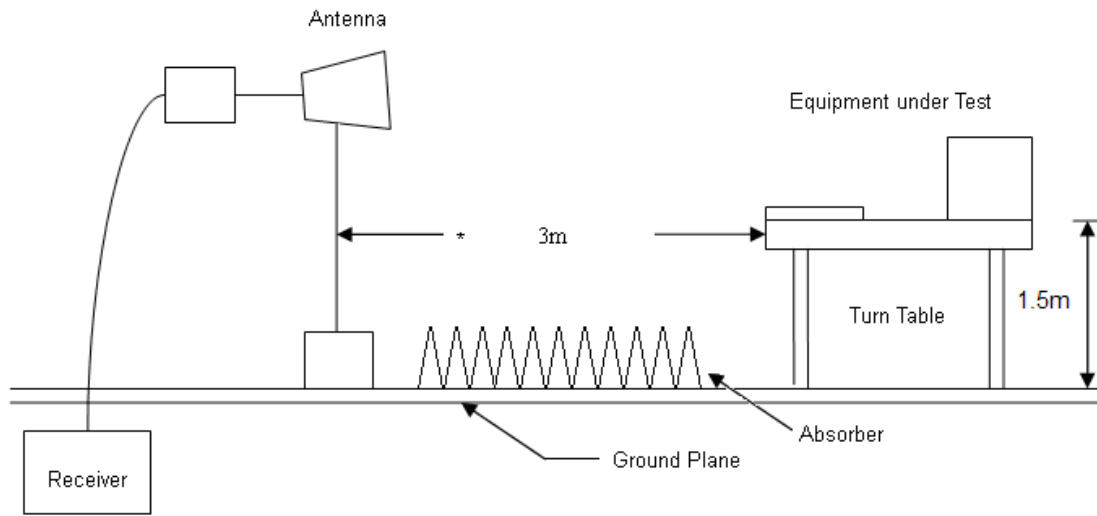



### 6.4 Test Result and Data

The 9kHz-30MHz spurious emission is under limit 20dB more.

#### 6.4.1 Test Result and Data of Transmitter

##### Below 1GHz

Power	: AC 120V	Pol/Phase	: VERTICAL
Test Mode	: Mode 1	Temperature	: 18 °C
Test Date	: Nov. 13, 2016	Humidity	: 49 %
Memo	: CH 00	Atmospheric Pressure	: 1008 hpa

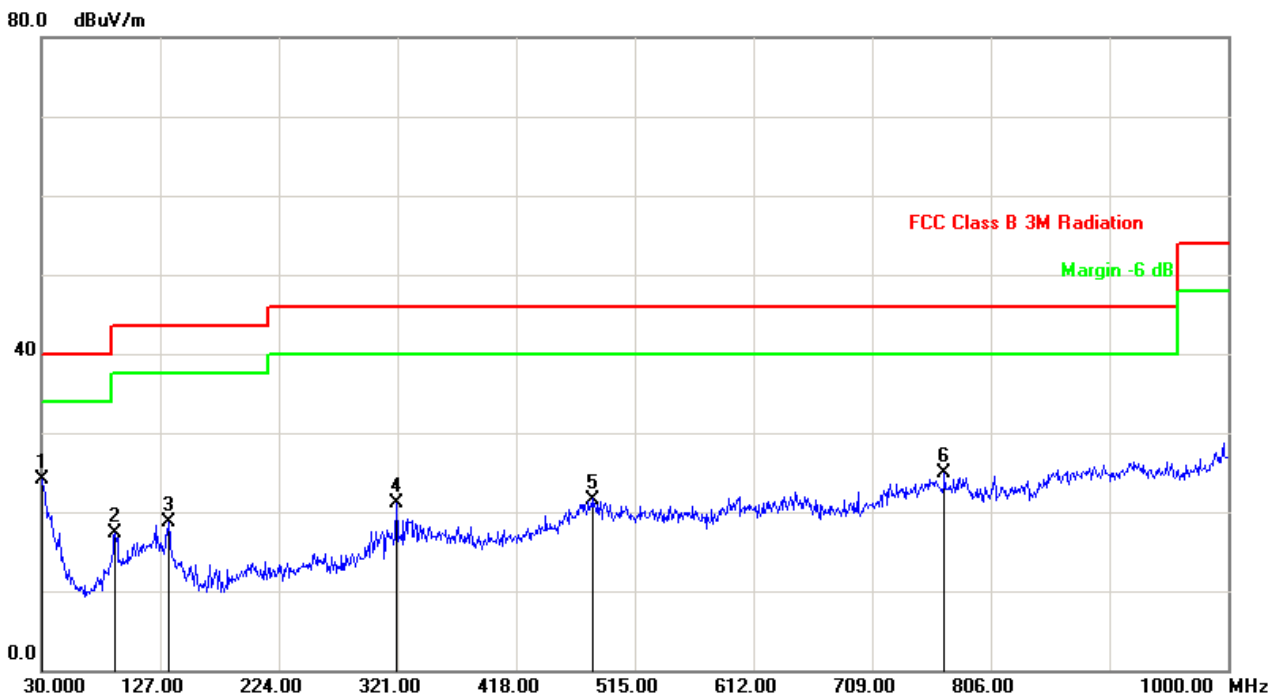

No.	Frequency (MHz)	Factor (dB/m)	Reading (dBuV)	Level (dBuV/m)	Limit (dBuV/m)	Margin (dB)	Det.	Height (cm)	Azimuth (deg)
1	30.0000	-3.01	27.14	24.13	40.00	-15.87	QP	100	343
2	90.1400	-11.37	28.73	17.36	43.50	-26.14	QP	100	325
3	133.7899	-9.38	28.15	18.77	43.50	-24.73	QP	100	0
4	320.0300	-6.77	27.86	21.09	46.00	-24.91	QP	200	108
5	480.0800	-1.10	22.70	21.60	46.00	-24.40	QP	100	206
6	768.1700	1.51	23.31	24.82	46.00	-21.18	QP	200	357

Note: Level = Reading + Factor

Margin = Level – Limit

Factor= Antenna Factor + Cable Loss - Amplifier Factor



Power	: AC 120V	Pol/Phase	: HORIZONTAL
Test Mode	: Mode 1	Temperature	: 18 °C
Test Date	: Nov. 13, 2016	Humidity	: 49 %
Memo	: CH 00	Atmospheric Pressure	: 1008 hpa

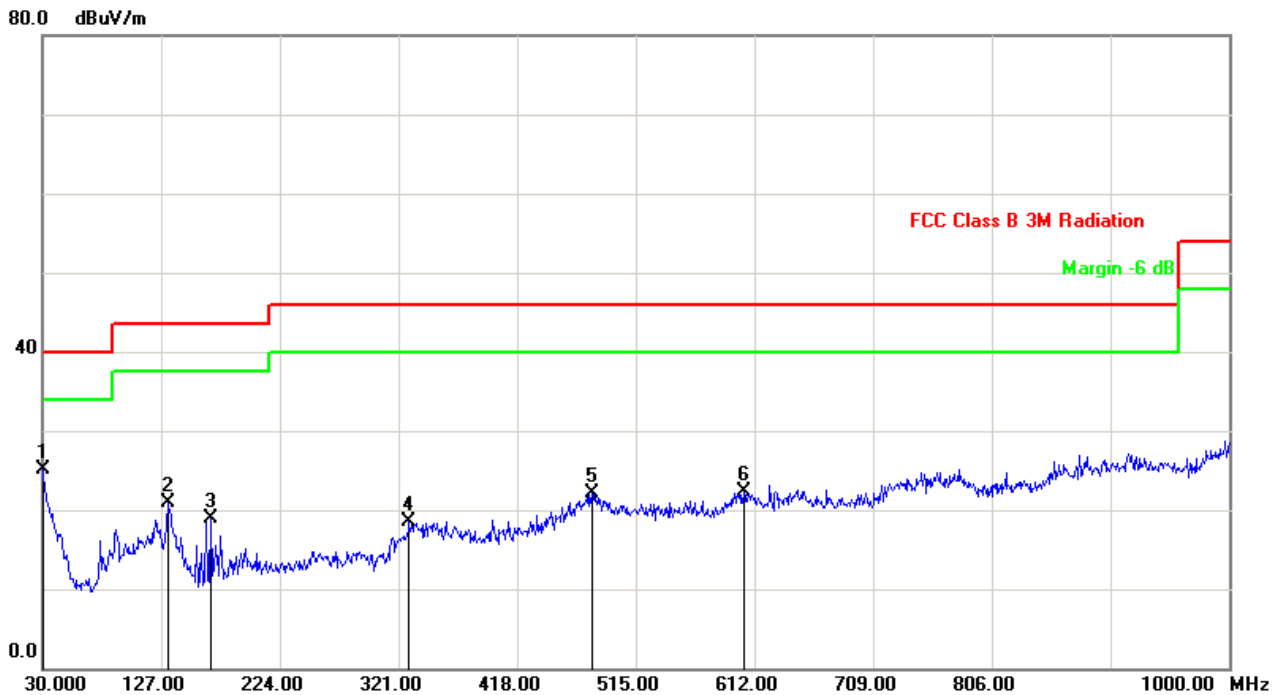

No.	Frequency (MHz)	Factor (dB/m)	Reading (dBuV)	Level (dBuV/m)	Limit (dBuV/m)	Margin (dB)	Det.	Height (cm)	Azimuth (deg)
1	30.0000	-3.01	28.16	25.15	40.00	-14.85	QP	100	333
2	132.8199	-9.28	30.25	20.97	43.50	-22.53	QP	200	69
3	167.7400	-11.97	30.84	18.87	43.50	-24.63	QP	100	0
4	329.7300	-4.13	22.66	18.53	46.00	-27.47	QP	200	359
5	479.1100	-1.14	23.33	22.19	46.00	-23.81	QP	300	197
6	603.2698	-1.17	23.50	22.33	46.00	-23.67	QP	100	359

Note: Level = Reading + Factor  
Margin = Level – Limit  
Factor= Antenna Factor + Cable Loss - Amplifier Factor



Above 1GHz

Power	: AC 120V	Pol/Phase	: HORIZONTAL
Test Mode	: Mode 1	Temperature	: 25 °C
Test Date	: Nov. 13, 2016	Humidity	: 52 %
Memo	: CH 00	Atmospheric Pressure	: 1010 hpa

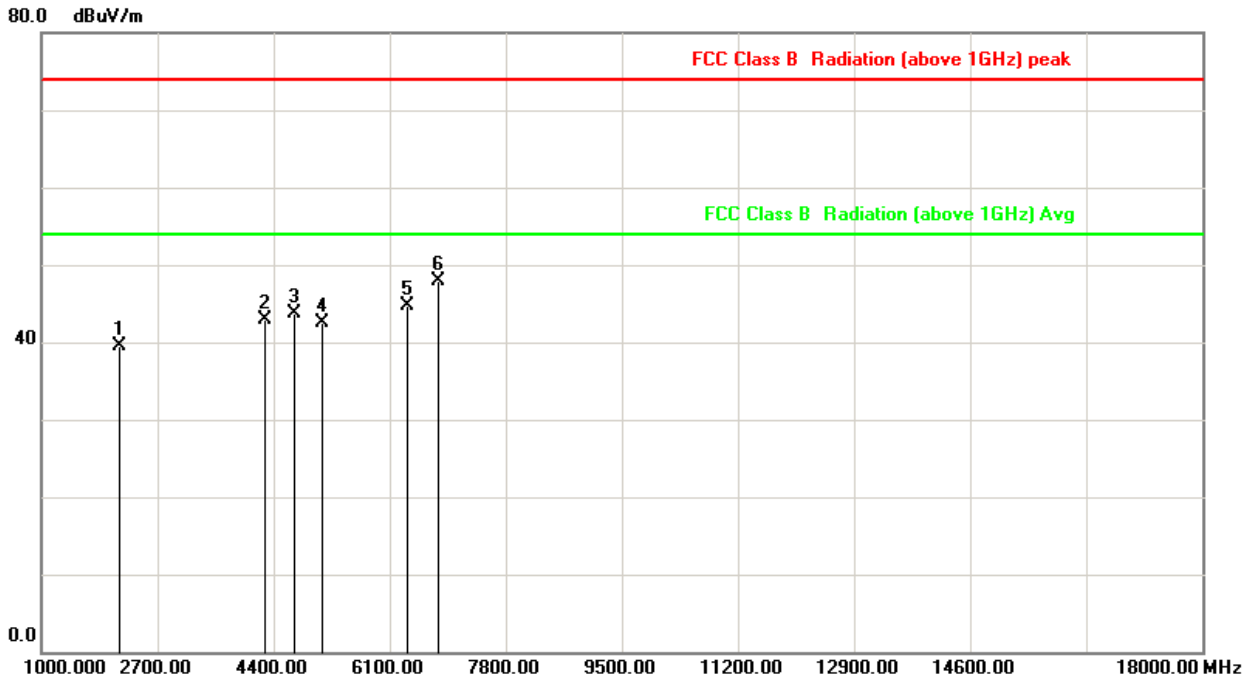

No.	Frequency (MHz)	Factor (dB/m)	Reading (dBuV)	Level (dBuV/m)	Limit (dBuV/m)	Margin (dB)	Detector
1	2147.500	-4.10	43.66	39.56	74.00	-34.44	peak
2	4272.500	6.50	36.38	42.88	74.00	-31.12	peak
3	4697.500	8.03	35.77	43.80	74.00	-30.20	peak
4	5122.500	8.70	33.89	42.59	74.00	-31.41	peak
5	6355.000	10.40	34.23	44.63	74.00	-29.37	peak
6	6822.500	11.50	36.33	47.83	74.00	-26.17	peak

Note: Level = Reading + Factor  
 Margin = Level – Limit  
 Factor= Antenna Factor + Cable Loss - Amplifier Factor



Power	: AC 120V	Pol/Phase	: VERTICAL
Test Mode	: Mode 1	Temperature	: 25 °C
Test Date	: Nov. 13, 2016	Humidity	: 52 %
Memo	: CH 00	Atmospheric Pressure	: 1010 hpa

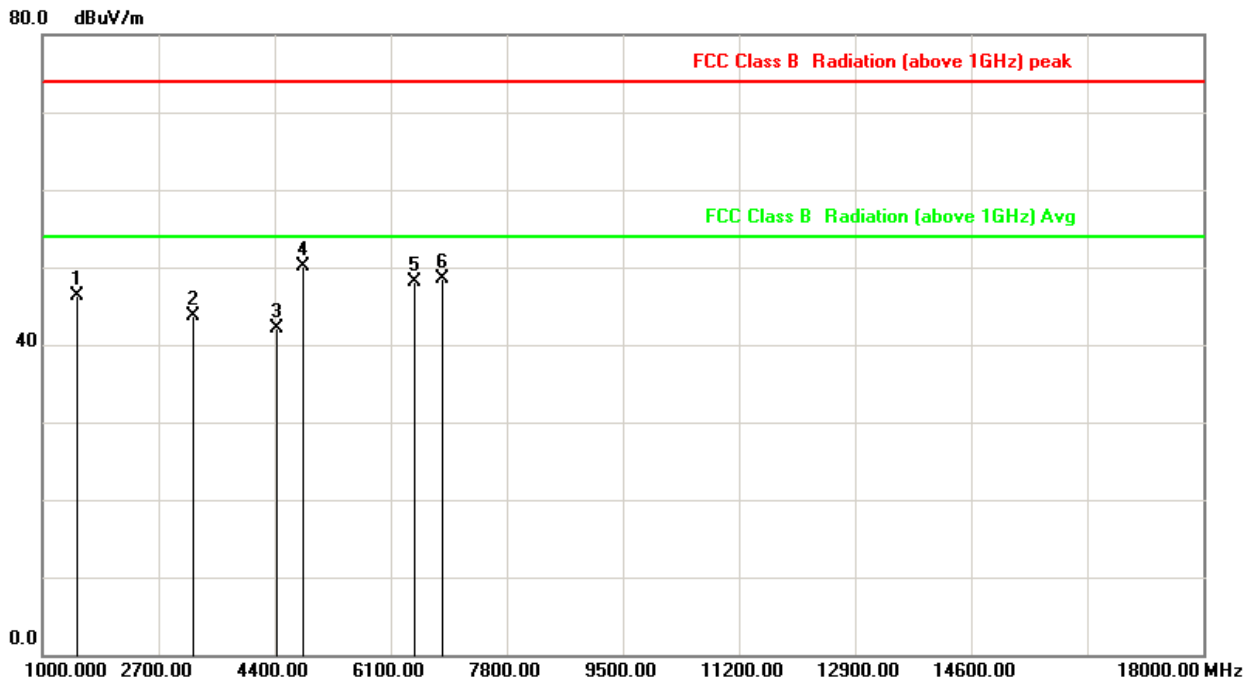

No.	Frequency (MHz)	Factor (dB/m)	Reading (dBuV)	Level (dBuV/m)	Limit (dBuV/m)	Margin (dB)	Detector
1	1510.000	-7.55	53.94	46.39	74.00	-27.61	peak
2	3210.000	1.87	41.93	43.80	74.00	-30.20	peak
3	4442.500	7.37	34.78	42.15	74.00	-31.85	peak
4	4825.000	8.27	41.83	50.10	74.00	-23.90	peak
5	6440.000	10.44	37.65	48.09	74.00	-25.91	peak
6	6865.000	11.64	36.87	48.51	74.00	-25.49	peak

Note: Level = Reading + Factor

Margin = Level – Limit

Factor= Antenna Factor + Cable Loss - Amplifier Factor



Power	: AC 120V	Pol/Phase	: HORIZONTAL
Test Mode	: Mode 1	Temperature	: 25 °C
Test Date	: Nov. 13, 2016	Humidity	: 52 %
Memo	: CH 39	Atmospheric Pressure	: 1010 hpa

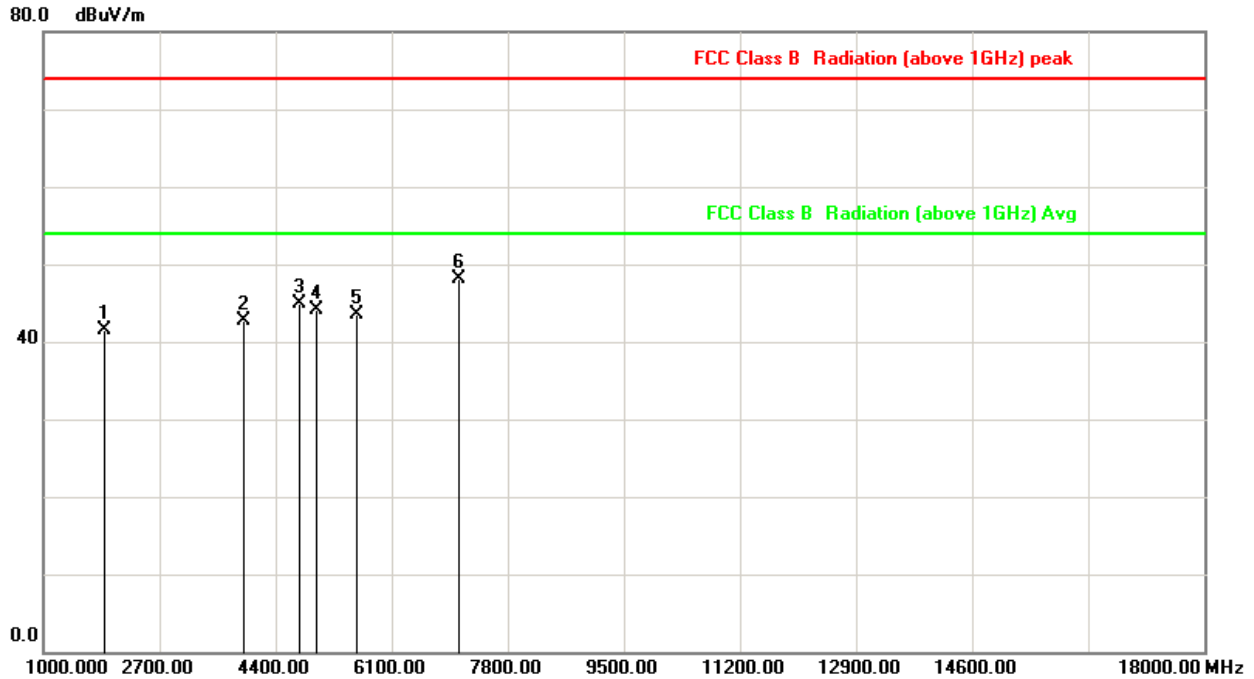

No.	Frequency (MHz)	Factor (dB/m)	Reading (dBuV)	Level (dBuV/m)	Limit (dBuV/m)	Margin (dB)	Detector
1	1892.500	-5.35	46.79	41.44	74.00	-32.56	peak
2	3932.500	4.88	37.85	42.73	74.00	-31.27	peak
3	4740.000	8.11	36.74	44.85	74.00	-29.15	peak
4	4995.000	8.59	35.43	44.02	74.00	-29.98	peak
5	5590.000	9.24	34.34	43.58	74.00	-30.42	peak
6	7077.500	12.38	35.67	48.05	74.00	-25.95	peak

Note: Level = Reading + Factor  
Margin = Level – Limit  
Factor= Antenna Factor + Cable Loss - Amplifier Factor





Power	: AC 120V	Pol/Phase	: VERTICAL
Test Mode	: Mode 1	Temperature	: 25 °C
Test Date	: Nov. 13, 2016	Humidity	: 52 %
Memo	: CH 39	Atmospheric Pressure	: 1010 hpa

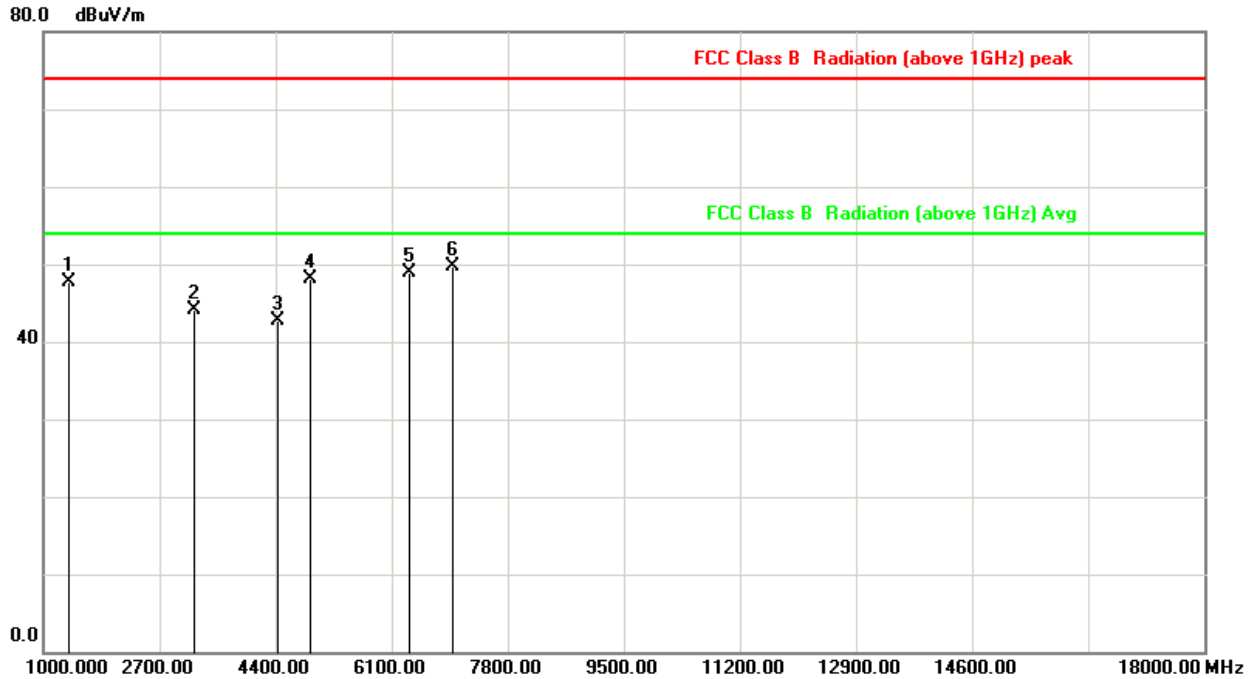

No.	Frequency (MHz)	Factor (dB/m)	Reading (dBuV)	Level (dBuV/m)	Limit (dBuV/m)	Margin (dB)	Detector
1	1382.500	-8.68	56.39	47.71	74.00	-26.29	peak
2	3210.000	1.87	42.19	44.06	74.00	-29.94	peak
3	4442.500	7.37	35.24	42.61	74.00	-31.39	peak
4	4910.000	8.43	39.69	48.12	74.00	-25.88	peak
5	6355.000	10.40	38.56	48.96	74.00	-25.04	peak
6	6992.500	12.06	37.69	49.75	74.00	-24.25	peak

Note: Level = Reading + Factor

Margin = Level – Limit

Factor= Antenna Factor + Cable Loss - Amplifier Factor



Power	: AC 120V	Pol/Phase	: HORIZONTAL
Test Mode	: Mode 1	Temperature	: 25 °C
Test Date	: Nov. 13, 2016	Humidity	: 52 %
Memo	: CH 78	Atmospheric Pressure	: 1010 hpa

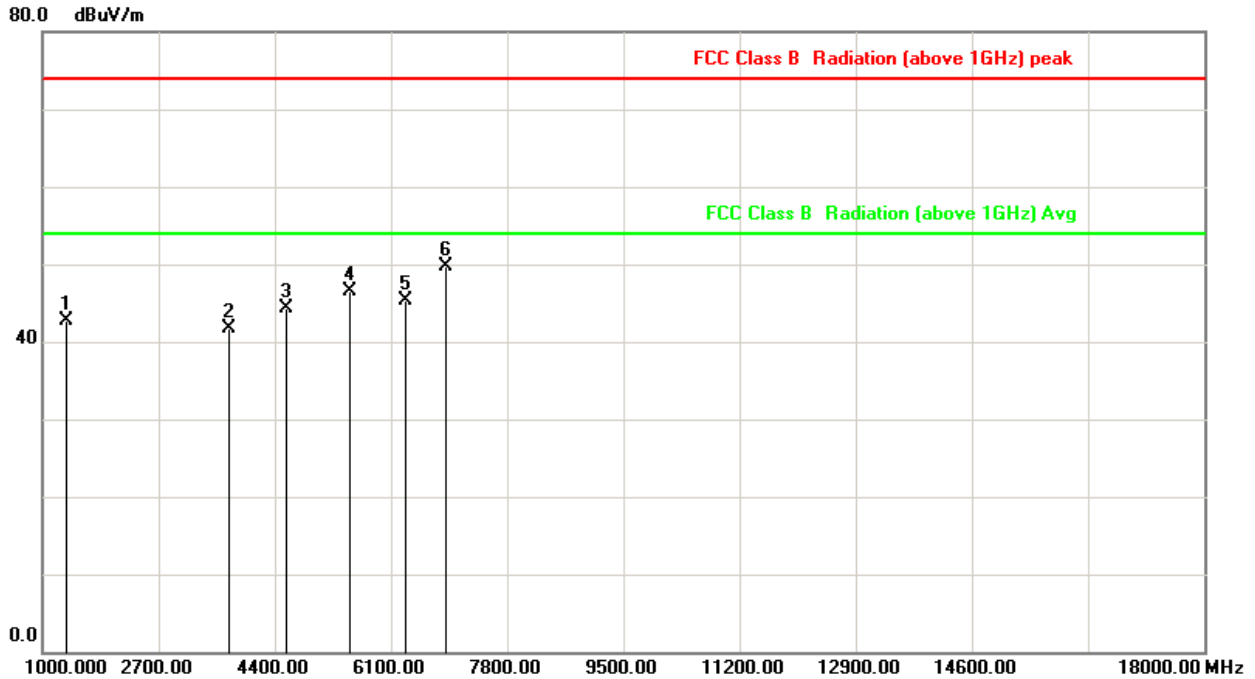

No.	Frequency (MHz)	Factor (dB/m)	Reading (dBuV)	Level (dBuV/m)	Limit (dBuV/m)	Margin (dB)	Detector
1	1340.000	-9.07	51.87	42.80	74.00	-31.20	peak
2	3720.000	4.15	37.55	41.70	74.00	-32.30	peak
3	4570.000	7.79	36.47	44.26	74.00	-29.74	peak
4	5505.000	9.03	37.39	46.42	74.00	-27.58	peak
5	6312.500	10.38	34.99	45.37	74.00	-28.63	peak
6	6907.500	11.78	37.96	49.74	74.00	-24.26	peak

Note: Level = Reading + Factor

Margin = Level – Limit

Factor= Antenna Factor + Cable Loss - Amplifier Factor



Power	: AC 120V	Pol/Phase	: VERTICAL
Test Mode	: Mode 1	Temperature	: 25 °C
Test Date	: Nov. 13, 2016	Humidity	: 52 %
Memo	: CH 78	Atmospheric Pressure	: 1010 hpa

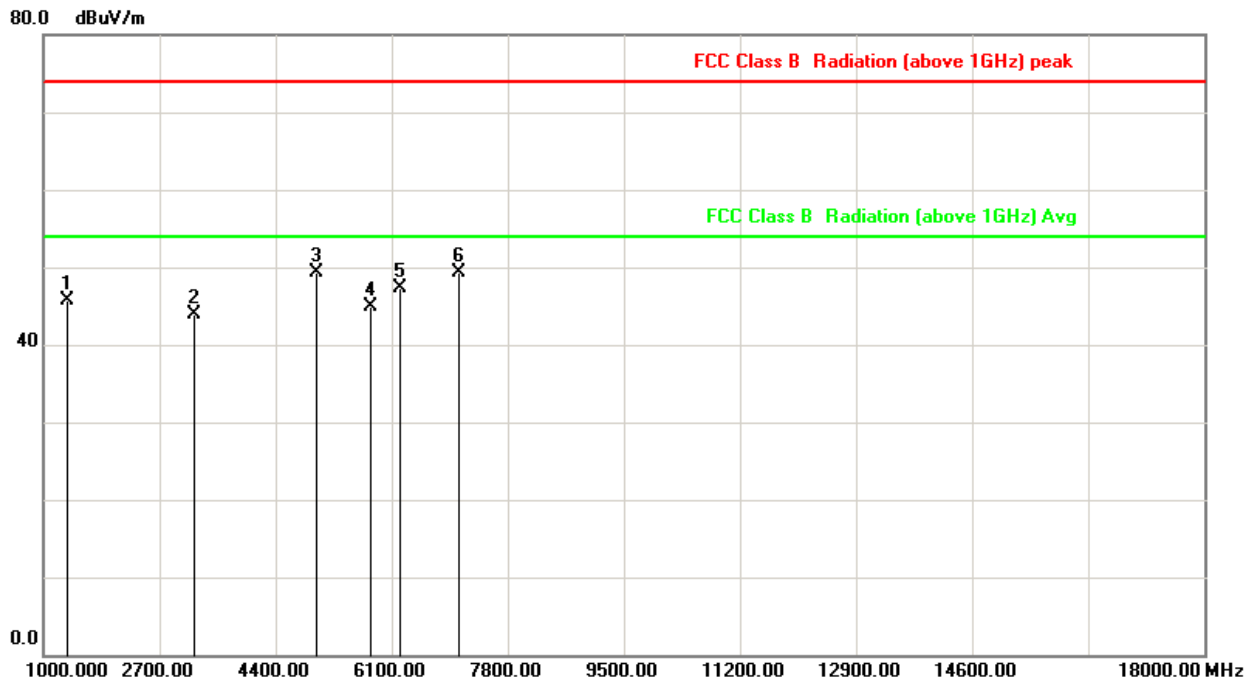

No.	Frequency (MHz)	Factor (dB/m)	Reading (dBuV)	Level (dBuV/m)	Limit (dBuV/m)	Margin (dB)	Detector
1	1340.000	-9.07	54.77	45.70	74.00	-28.30	peak
2	3210.000	1.87	42.08	43.95	74.00	-30.05	peak
3	4995.000	8.59	40.64	49.23	74.00	-24.77	peak
4	5802.500	9.77	35.18	44.95	74.00	-29.05	peak
5	6227.500	10.35	36.94	47.29	74.00	-26.71	peak
6	7077.500	12.38	36.85	49.23	74.00	-24.77	peak

Note: Level = Reading + Factor

Margin = Level – Limit

Factor= Antenna Factor + Cable Loss - Amplifier Factor



Power	: AC 120V	Pol/Phase	: HORIZONTAL
Test Mode	: Mode 2	Temperature	: 25 °C
Test Date	: Nov. 13, 2016	Humidity	: 52 %
Memo	: CH 00	Atmospheric Pressure	: 1010 hpa

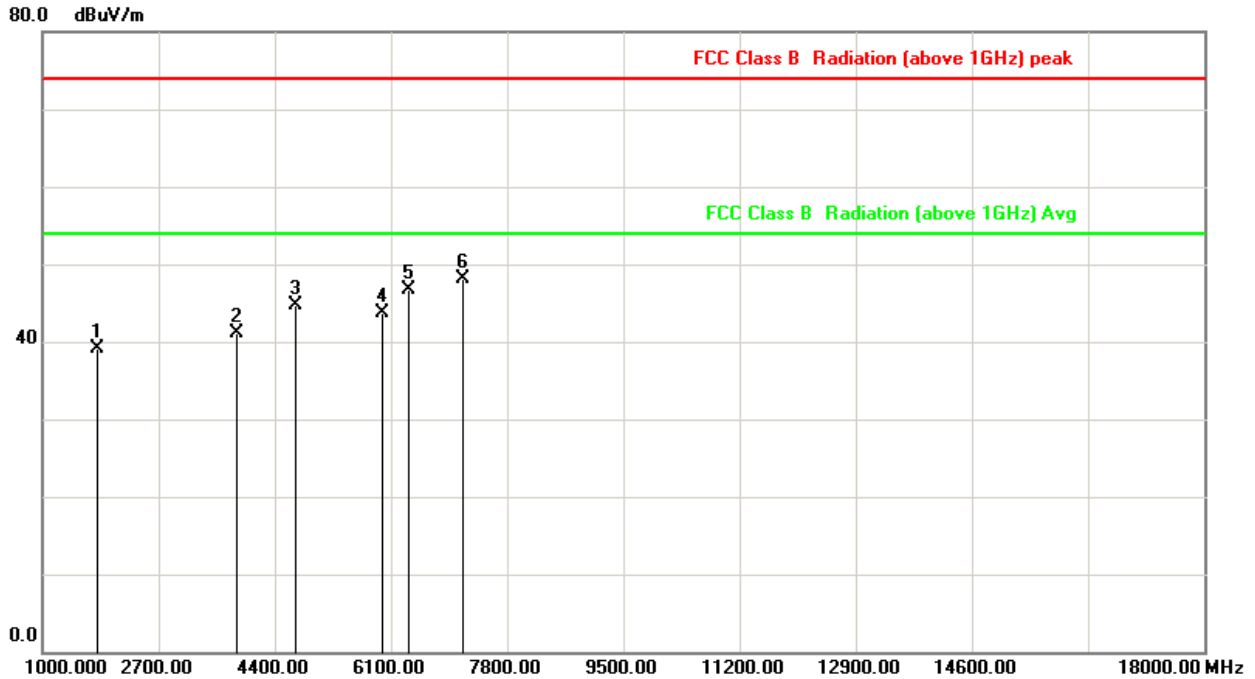

No.	Frequency (MHz)	Factor (dB/m)	Reading (dBuV)	Level (dBuV/m)	Limit (dBuV/m)	Margin (dB)	Detector
1	1807.500	-5.84	44.86	39.02	74.00	-34.98	peak
2	3847.500	4.59	36.42	41.01	74.00	-32.99	peak
3	4697.500	8.03	36.77	44.80	74.00	-29.20	peak
4	5972.500	10.19	33.51	43.70	74.00	-30.30	peak
5	6355.000	10.40	36.23	46.63	74.00	-27.37	peak
6	7162.500	12.71	35.40	48.11	74.00	-25.89	peak

Note: Level = Reading + Factor  
Margin = Level – Limit  
Factor= Antenna Factor + Cable Loss - Amplifier Factor



Power	: AC 120V	Pol/Phase	: VERTICAL
Test Mode	: Mode 2	Temperature	: 25 °C
Test Date	: Nov. 13, 2016	Humidity	: 52 %
Memo	: CH 00	Atmospheric Pressure	: 1010 hpa

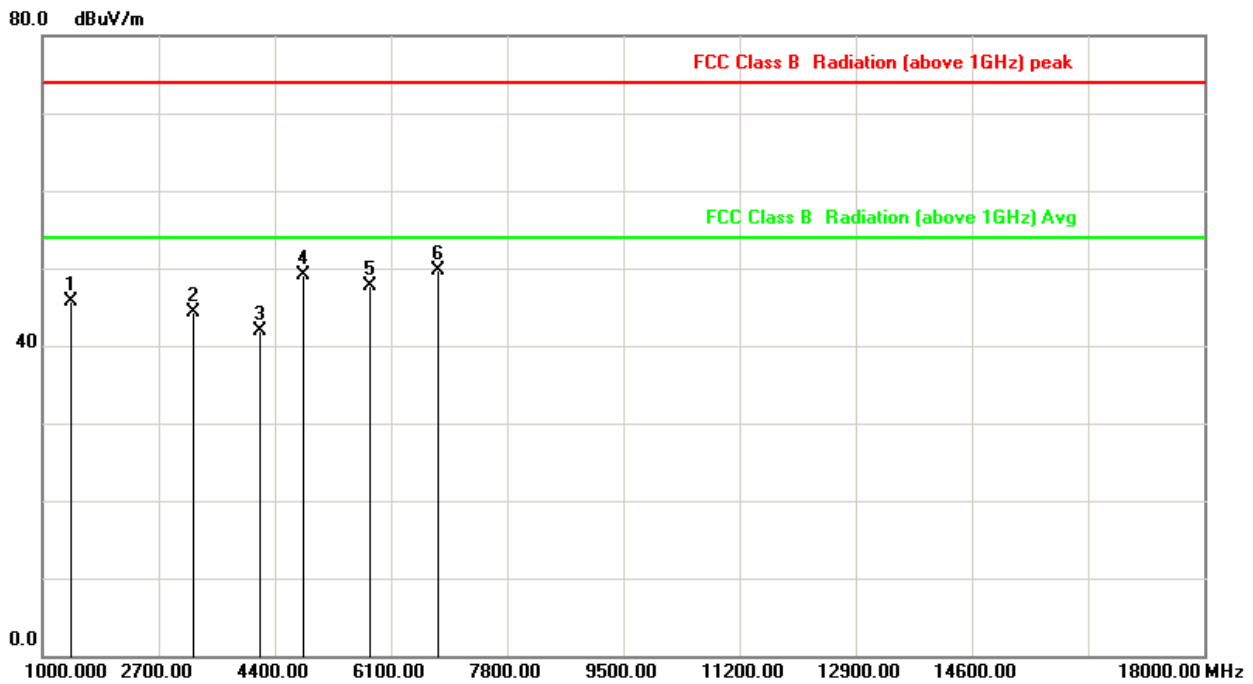

No.	Frequency (MHz)	Factor (dB/m)	Reading (dBuV)	Level (dBuV/m)	Limit (dBuV/m)	Margin (dB)	Detector
1	1425.000	-8.29	54.09	45.80	74.00	-28.20	peak
2	3210.000	1.87	42.43	44.30	74.00	-29.70	peak
3	4187.500	6.07	35.74	41.81	74.00	-32.19	peak
4	4825.000	8.27	40.83	49.10	74.00	-24.90	peak
5	5802.500	9.77	37.97	47.74	74.00	-26.26	peak
6	6780.000	11.37	38.36	49.73	74.00	-24.27	peak

Note: Level = Reading + Factor  
Margin = Level – Limit  
Factor= Antenna Factor + Cable Loss - Amplifier Factor



Power	: AC 120V	Pol/Phase	: HORIZONTAL
Test Mode	: Mode 2	Temperature	: 25 °C
Test Date	: Nov. 13, 2016	Humidity	: 52 %
Memo	: CH 39	Atmospheric Pressure	: 1010 hpa

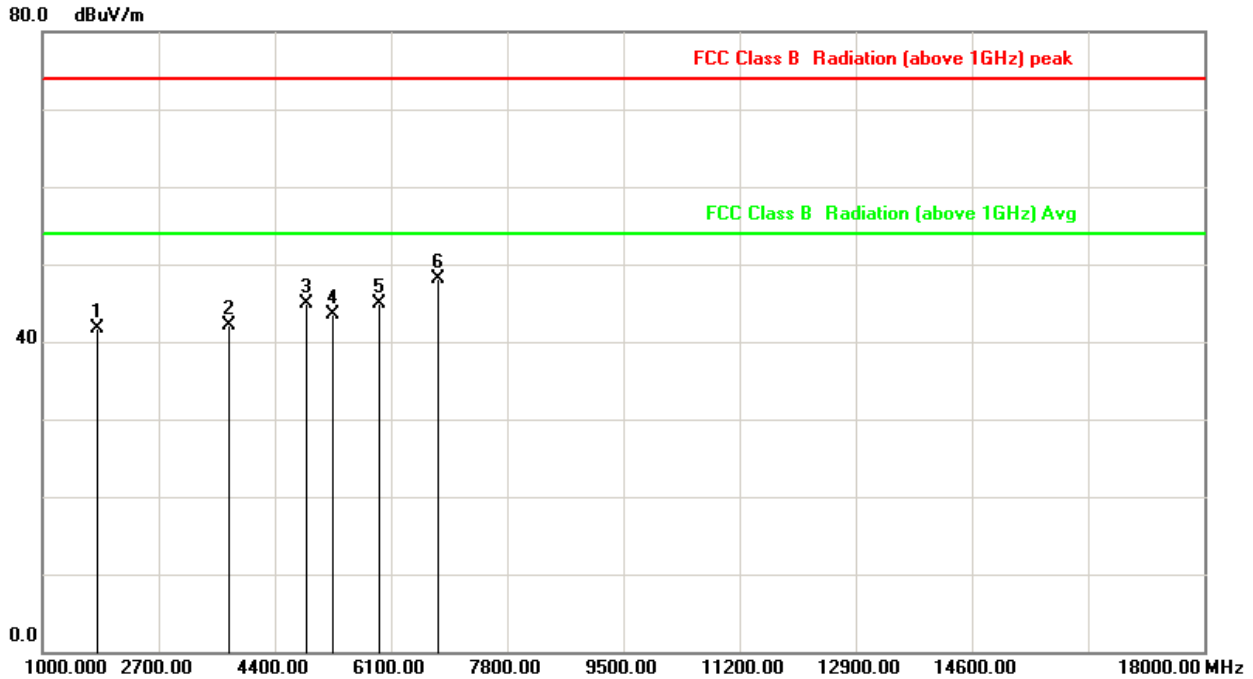

No.	Frequency (MHz)	Factor (dB/m)	Reading (dBuV)	Level (dBuV/m)	Limit (dBuV/m)	Margin (dB)	Detector
1	1807.500	-5.84	47.51	41.67	74.00	-32.33	peak
2	3720.000	4.15	37.89	42.04	74.00	-31.96	peak
3	4867.500	8.35	36.53	44.88	74.00	-29.12	peak
4	5250.000	8.81	34.71	43.52	74.00	-30.48	peak
5	5930.000	10.09	34.80	44.89	74.00	-29.11	peak
6	6780.000	11.37	36.82	48.19	74.00	-25.81	peak

Note: Level = Reading + Factor

Margin = Level – Limit

Factor= Antenna Factor + Cable Loss - Amplifier Factor



Power	: AC 120V	Pol/Phase	: VERTICAL
Test Mode	: Mode 2	Temperature	: 25 °C
Test Date	: Nov. 13, 2016	Humidity	: 52 %
Memo	: CH 39	Atmospheric Pressure	: 1010 hpa

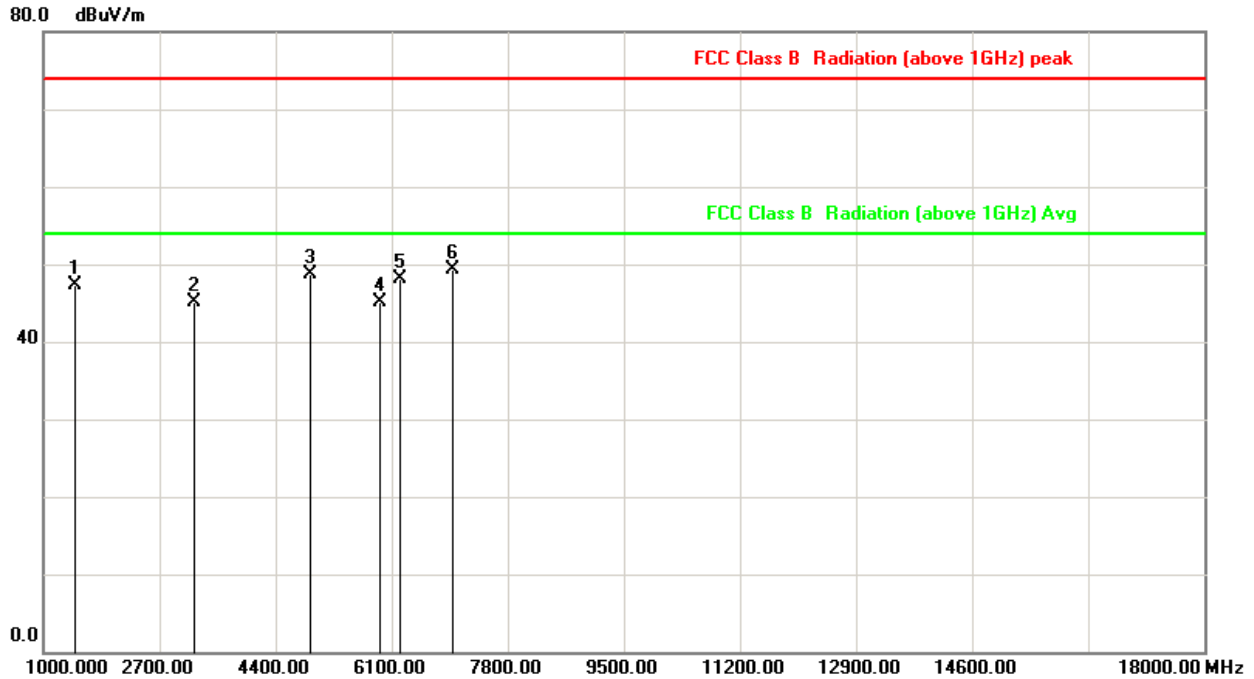

No.	Frequency (MHz)	Factor (dB/m)	Reading (dBuV)	Level (dBuV/m)	Limit (dBuV/m)	Margin (dB)	Detector
1	1467.500	-7.91	55.24	47.33	74.00	-26.67	peak
2	3210.000	1.87	43.19	45.06	74.00	-28.94	peak
3	4910.000	8.43	40.19	48.62	74.00	-25.38	peak
4	5930.000	10.09	35.04	45.13	74.00	-28.87	peak
5	6227.500	10.35	37.81	48.16	74.00	-25.84	peak
6	6992.500	12.06	37.19	49.25	74.00	-24.75	peak

Note: Level = Reading + Factor  
 Margin = Level – Limit  
 Factor= Antenna Factor + Cable Loss - Amplifier Factor



Power	: AC 120V	Pol/Phase	: HORIZONTAL
Test Mode	: Mode 2	Temperature	: 25 °C
Test Date	: Nov. 13, 2016	Humidity	: 52 %
Memo	: CH 78	Atmospheric Pressure	: 1010 hpa

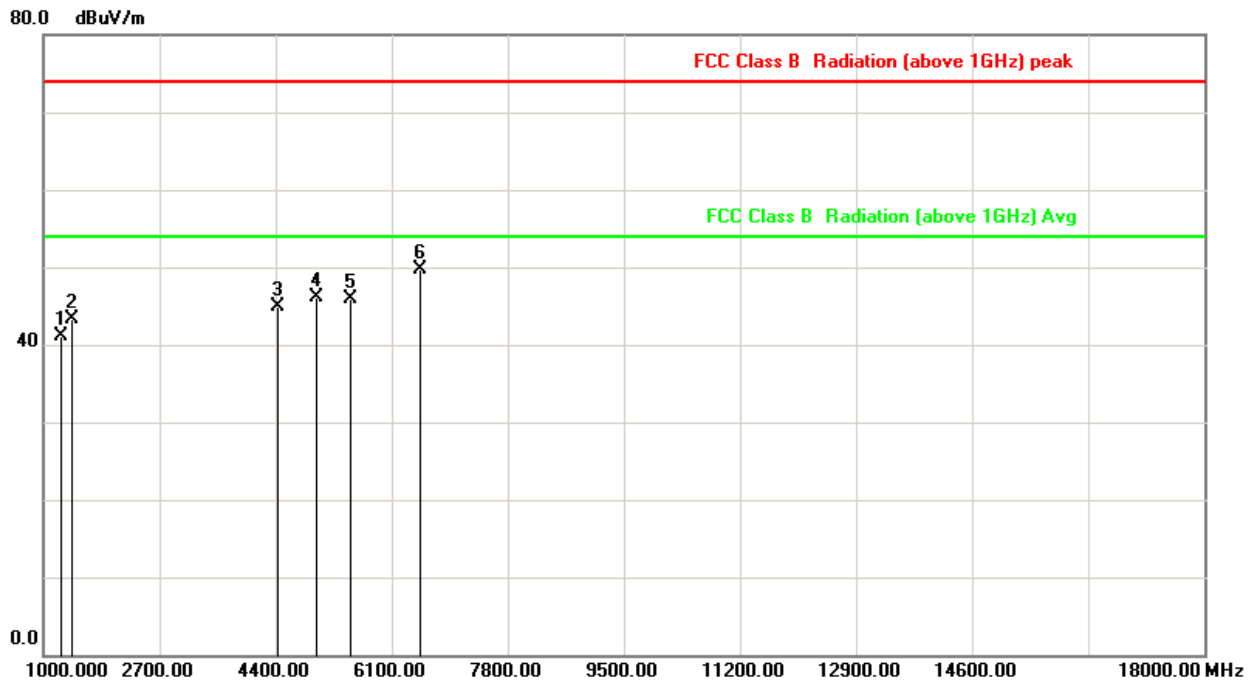

No.	Frequency (MHz)	Factor (dB/m)	Reading (dBuV)	Level (dBuV/m)	Limit (dBuV/m)	Margin (dB)	Detector
1	1255.000	-9.84	50.85	41.01	74.00	-32.99	peak
2	1425.000	-8.29	51.57	43.28	74.00	-30.72	peak
3	4442.500	7.37	37.52	44.89	74.00	-29.11	peak
4	4995.000	8.59	37.46	46.05	74.00	-27.95	peak
5	5505.000	9.03	36.89	45.92	74.00	-28.08	peak
6	6525.000	10.54	39.08	49.62	74.00	-24.38	peak

Note: Level = Reading + Factor  
Margin = Level - Limit  
Factor= Antenna Factor + Cable Loss - Amplifier Factor





Power	: AC 120V	Pol/Phase	: VERTICAL
Test Mode	: Mode 2	Temperature	: 25 °C
Test Date	: Nov. 13, 2016	Humidity	: 52 %
Memo	: CH 78	Atmospheric Pressure	: 1010 hpa

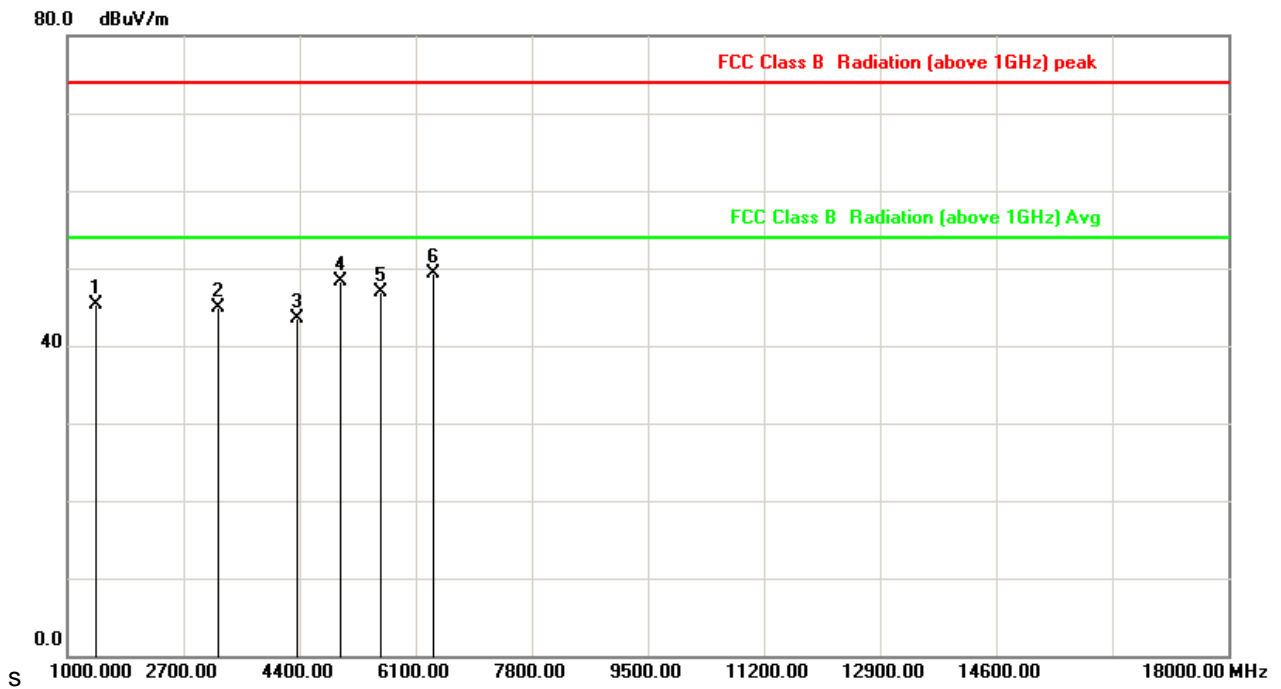

No.	Frequency (MHz)	Factor (dB/m)	Reading (dBuV)	Level (dBuV/m)	Limit (dBuV/m)	Margin (dB)	Detector
1	1425.000	-8.29	53.69	45.40	74.00	-28.60	peak
2	3210.000	1.87	43.08	44.95	74.00	-29.05	peak
3	4357.500	6.93	36.58	43.51	74.00	-30.49	peak
4	4995.000	8.59	39.64	48.23	74.00	-25.77	peak
5	5590.000	9.24	37.57	46.81	74.00	-27.19	peak
6	6355.000	10.40	38.98	49.38	74.00	-24.62	peak

Note: Level = Reading + Factor  
 Margin = Level – Limit  
 Factor= Antenna Factor + Cable Loss - Amplifier Factor



Power	: AC 120V	Pol/Phase	: HORIZONTAL
Test Mode	: Mode 3	Temperature	: 25 °C
Test Date	: Nov. 13, 2016	Humidity	: 52 %
Memo	: CH 00	Atmospheric Pressure	: 1010 hpa

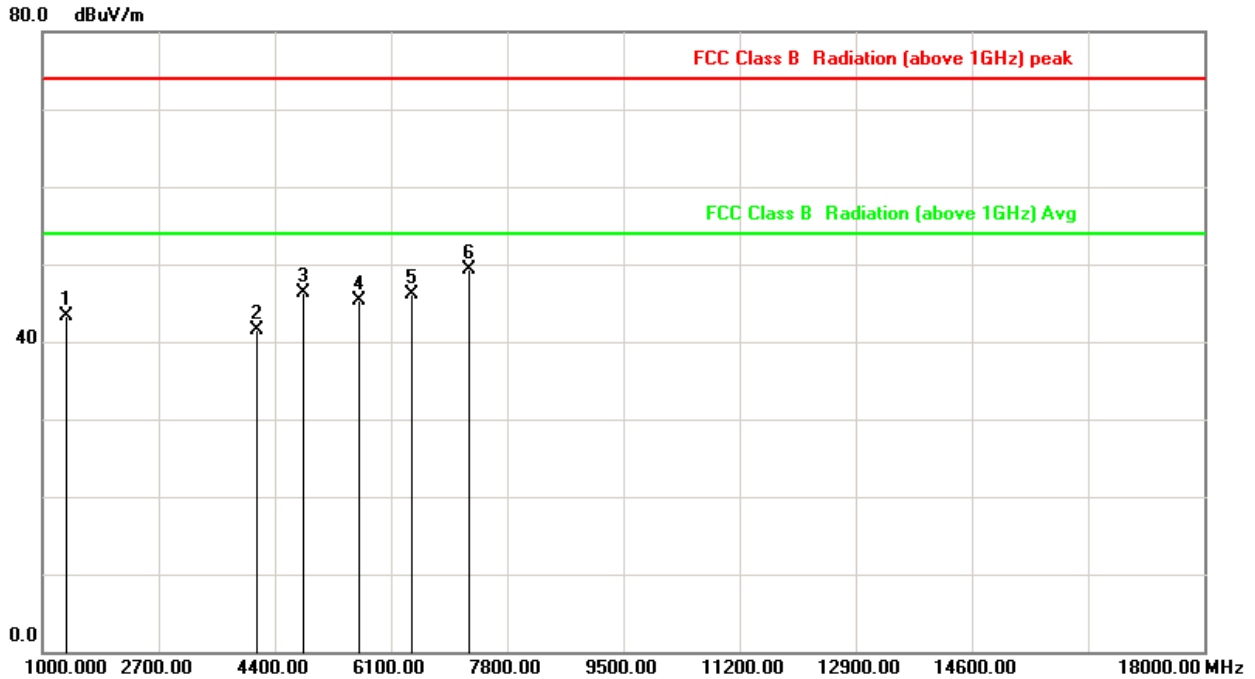

No.	Frequency (MHz)	Factor (dB/m)	Reading (dBuV)	Level (dBuV/m)	Limit (dBuV/m)	Margin (dB)	Detector
1	1340.000	-9.07	52.47	43.40	74.00	-30.60	peak
2	4145.000	5.85	35.64	41.49	74.00	-32.51	peak
3	4825.000	8.27	38.01	46.28	74.00	-27.72	peak
4	5632.500	9.35	35.97	45.32	74.00	-28.68	peak
5	6397.500	10.42	35.62	46.04	74.00	-27.96	peak
6	7247.500	13.05	36.23	49.28	74.00	-24.72	peak

Note: Level = Reading + Factor

Margin = Level - Limit

Factor= Antenna Factor + Cable Loss - Amplifier Factor



Power	: AC 120V	Pol/Phase	: VERTICAL
Test Mode	: Mode 3	Temperature	: 25 °C
Test Date	: Nov. 13, 2016	Humidity	: 52 %
Memo	: CH 00	Atmospheric Pressure	: 1010 hpa

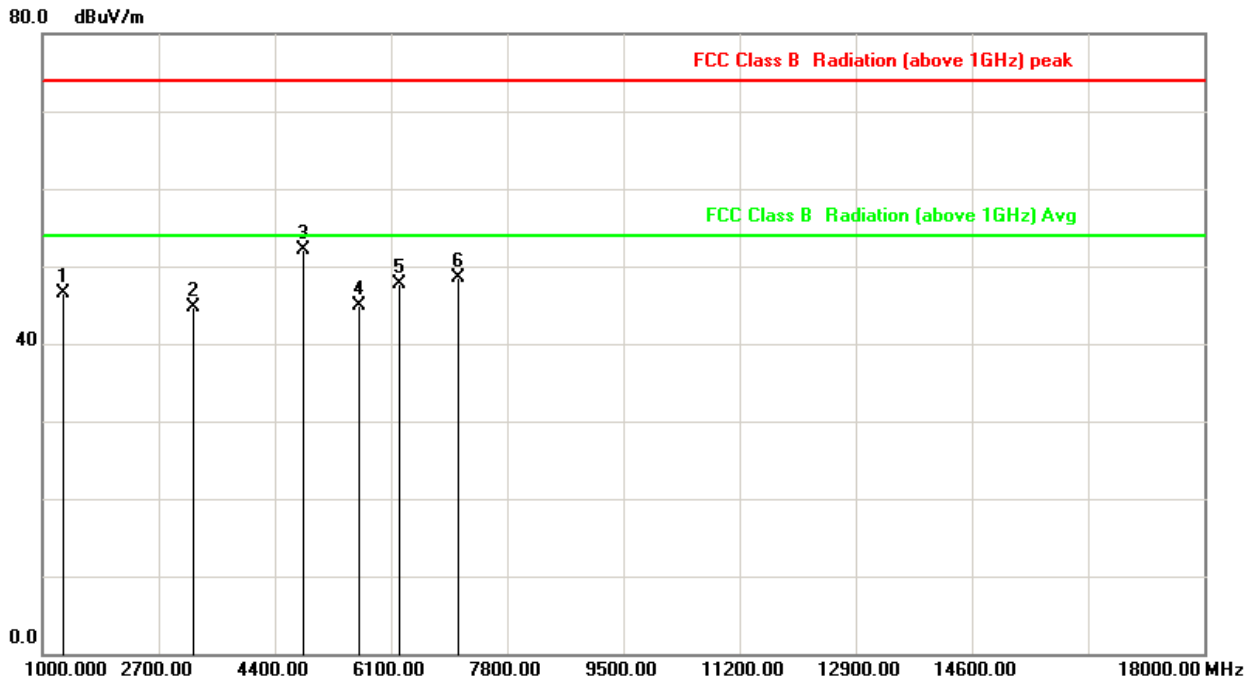

No.	Frequency (MHz)	Factor (dB/m)	Reading (dBuV)	Level (dBuV/m)	Limit (dBuV/m)	Margin (dB)	Detector
1	1297.500	-9.46	55.88	46.42	74.00	-27.58	peak
2	3210.000	1.87	42.93	44.80	74.00	-29.20	peak
3	4825.000	8.27	43.83	52.10	74.00	-21.90	peak
4	5632.500	9.35	35.65	45.00	74.00	-29.00	peak
5	6227.500	10.35	37.29	47.64	74.00	-26.36	peak
6	7077.500	12.38	36.03	48.41	74.00	-25.59	peak

Note: Level = Reading + Factor  
Margin = Level – Limit  
Factor= Antenna Factor + Cable Loss - Amplifier Factor



Power	: AC 120V	Pol/Phase	: HORIZONTAL
Test Mode	: Mode 3	Temperature	: 25 °C
Test Date	: Nov. 13, 2016	Humidity	: 52 %
Memo	: CH 39	Atmospheric Pressure	: 1010 hpa

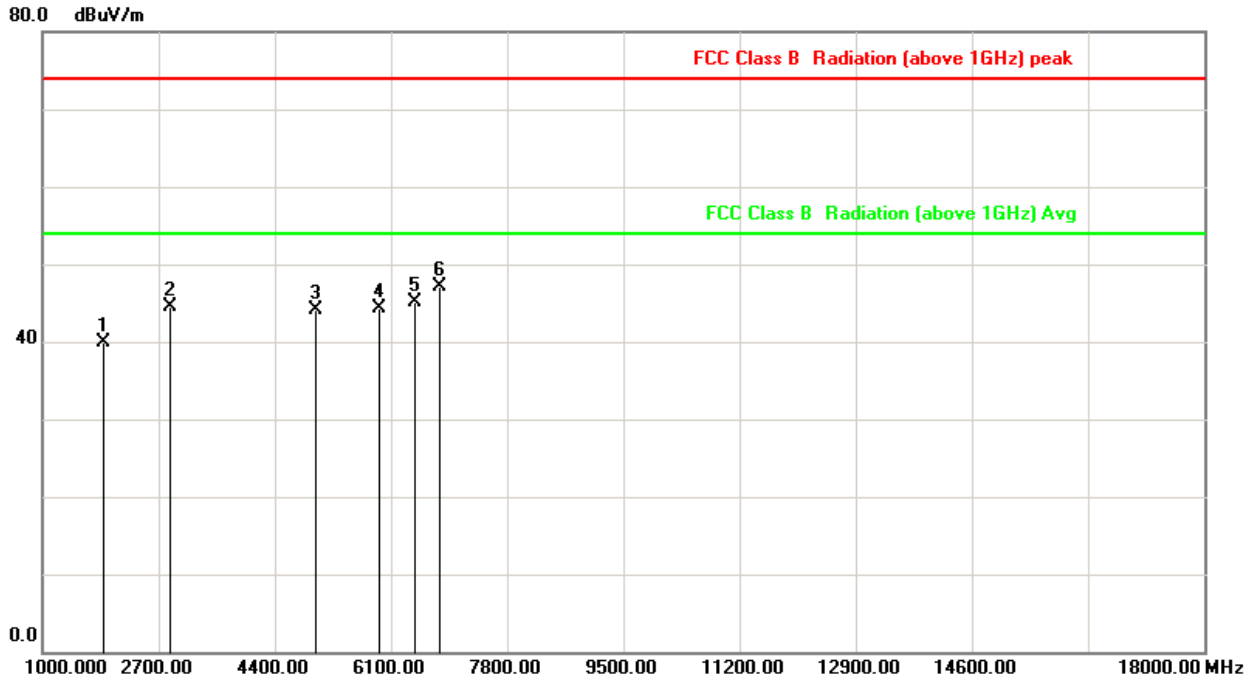

No.	Frequency (MHz)	Factor (dB/m)	Reading (dBuV)	Level (dBuV/m)	Limit (dBuV/m)	Margin (dB)	Detector
1	1892.500	-5.35	45.29	39.94	74.00	-34.06	peak
2	2870.000	-0.10	44.56	44.46	74.00	-29.54	peak
3	4995.000	8.59	35.43	44.02	74.00	-29.98	peak
4	5930.000	10.09	34.30	44.39	74.00	-29.61	peak
5	6440.000	10.44	34.72	45.16	74.00	-28.84	peak
6	6822.500	11.50	35.54	47.04	74.00	-26.96	peak

Note: Level = Reading + Factor  
Margin = Level – Limit  
Factor= Antenna Factor + Cable Loss - Amplifier Factor



Power	: AC 120V	Pol/Phase	: VERTICAL
Test Mode	: Mode 3	Temperature	: 25 °C
Test Date	: Nov. 13, 2016	Humidity	: 52 %
Memo	: CH 39	Atmospheric Pressure	: 1010 hpa

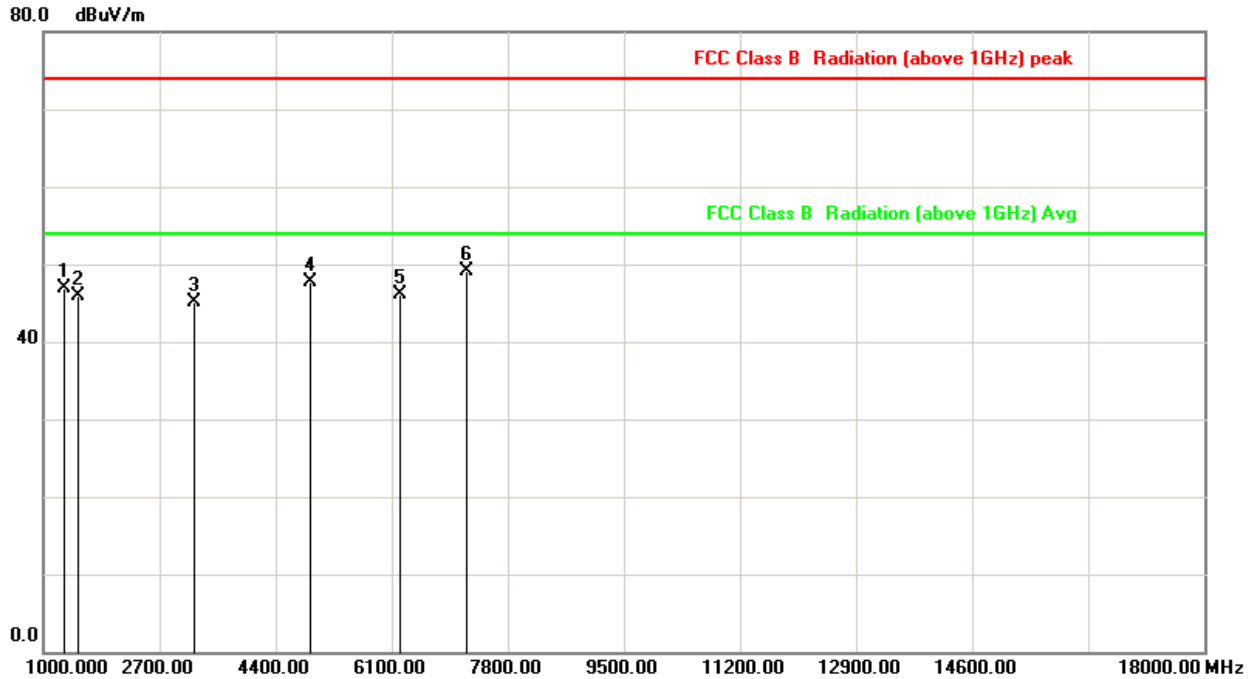

No.	Frequency (MHz)	Factor (dB/m)	Reading (dBuV)	Level (dBuV/m)	Limit (dBuV/m)	Margin (dB)	Detector
1	1297.500	-9.46	56.41	46.95	74.00	-27.05	peak
2	1510.000	-7.55	53.45	45.90	74.00	-28.10	peak
3	3210.000	1.87	43.19	45.06	74.00	-28.94	peak
4	4910.000	8.43	39.19	47.62	74.00	-26.38	peak
5	6227.500	10.35	35.81	46.16	74.00	-27.84	peak
6	7205.000	12.88	36.22	49.10	74.00	-24.90	peak

Note: Level = Reading + Factor  
 Margin = Level – Limit  
 Factor= Antenna Factor + Cable Loss - Amplifier Factor



Power	: AC 120V	Pol/Phase	: HORIZONTAL
Test Mode	: Mode 3	Temperature	: 25 °C
Test Date	: Nov. 13, 2016	Humidity	: 52 %
Memo	: CH 78	Atmospheric Pressure	: 1010 hpa

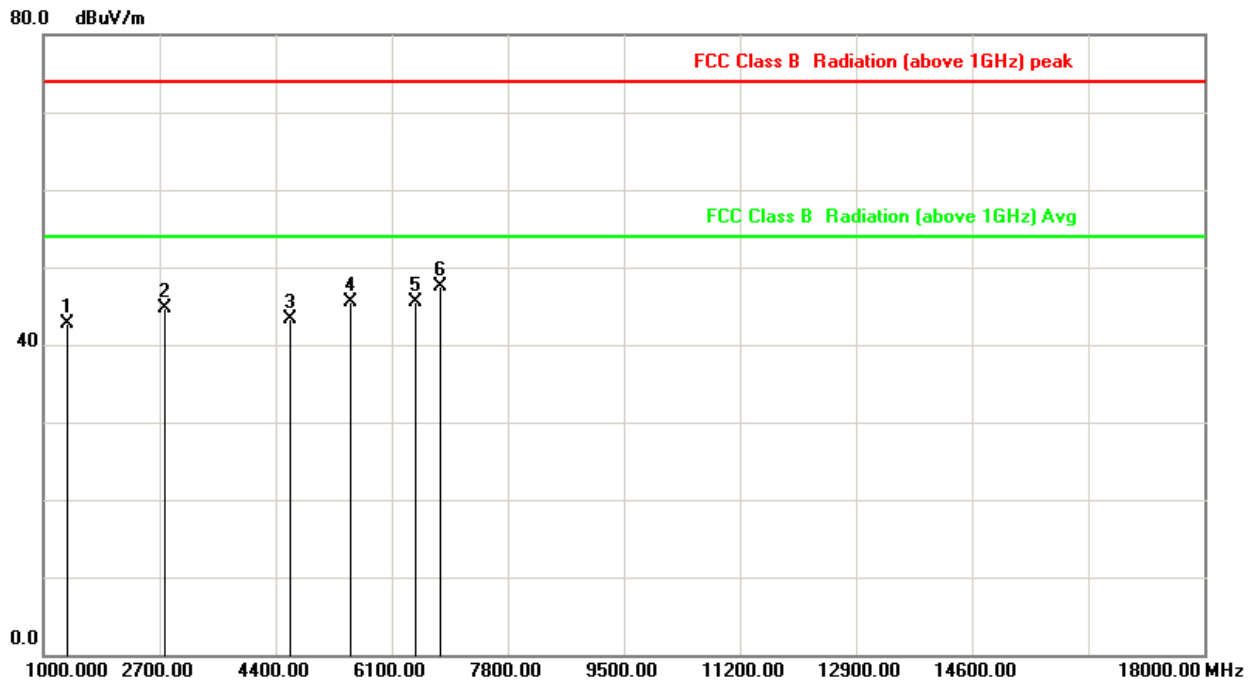

No.	Frequency (MHz)	Factor (dB/m)	Reading (dBuV)	Level (dBuV/m)	Limit (dBuV/m)	Margin (dB)	Detector
1	1340.000	-9.07	51.87	42.80	74.00	-31.20	peak
2	2785.000	-0.67	45.38	44.71	74.00	-29.29	peak
3	4612.500	7.87	35.44	43.31	74.00	-30.69	peak
4	5505.000	9.03	36.39	45.42	74.00	-28.58	peak
5	6440.000	10.44	34.98	45.42	74.00	-28.58	peak
6	6822.500	11.50	35.99	47.49	74.00	-26.51	peak

Note: Level = Reading + Factor  
Margin = Level – Limit  
Factor= Antenna Factor + Cable Loss - Amplifier Factor



Power	: AC 120V	Pol/Phase	: VERTICAL
Test Mode	: Mode 3	Temperature	: 25 °C
Test Date	: Nov. 13, 2016	Humidity	: 52 %
Memo	: CH 78	Atmospheric Pressure	: 1010 hpa

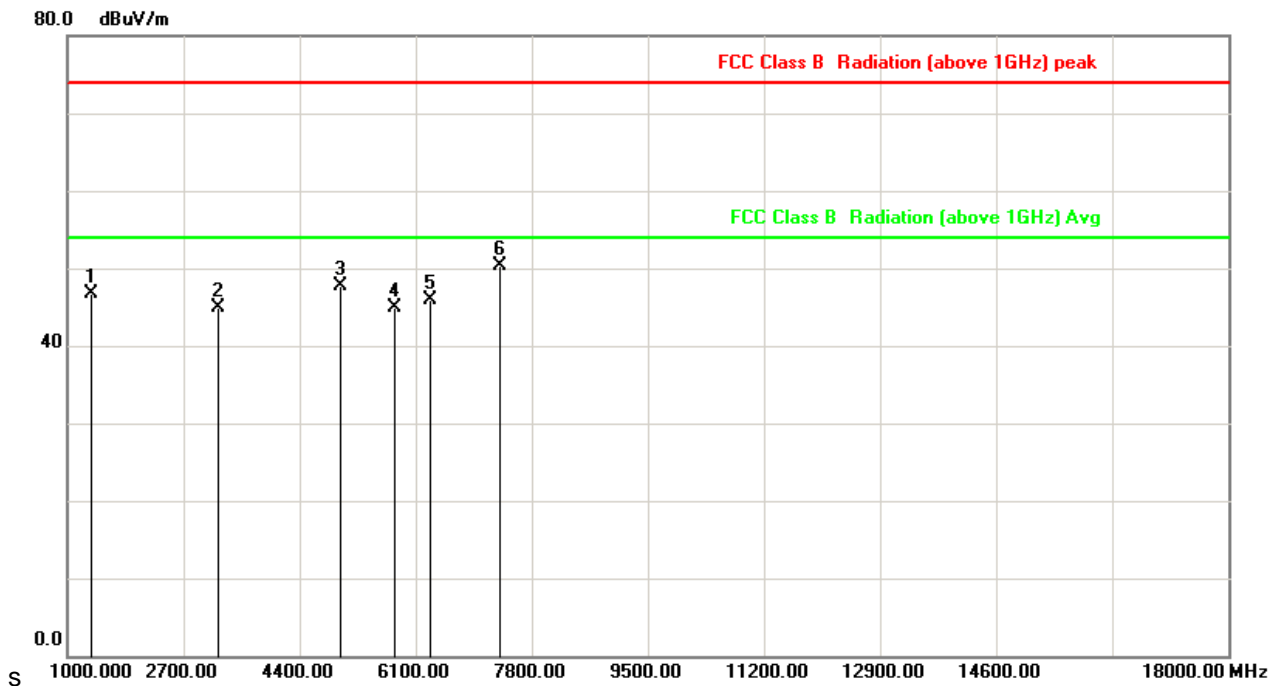

No.	Frequency (MHz)	Factor (dB/m)	Reading (dBuV)	Level (dBuV/m)	Limit (dBuV/m)	Margin (dB)	Detector
1	1340.000	-9.07	55.77	46.70	74.00	-27.30	peak
2	3210.000	1.87	43.08	44.95	74.00	-29.05	peak
3	4995.000	8.59	39.14	47.73	74.00	-26.27	peak
4	5802.500	9.77	35.18	44.95	74.00	-29.05	peak
5	6312.500	10.38	35.47	45.85	74.00	-28.15	peak
6	7332.500	13.38	36.90	50.28	74.00	-23.72	peak

Note: Level = Reading + Factor  
 Margin = Level – Limit  
 Factor= Antenna Factor + Cable Loss - Amplifier Factor



## 7. 20dB Bandwidth Measurement Data

### 7.1 Test Limit

Frequency hopping systems shall have hopping channel carrier frequencies separated by a minimum of 25 kHz or the 20 dB bandwidth of the hopping channel, whichever is greater. Alternatively, frequency hopping systems operating in the 2400–2483.5 MHz band may have hopping channel carrier frequencies that are separated by 25 kHz or two-thirds of the 20 dB bandwidth of the hopping channel, whichever is greater, provided the systems operate with an output power no greater than 125 mW.

### 7.2 Test Procedures

- The transmitter output was connected to the spectrum analyzer.
- Set RBW of spectrum analyzer to 30 KHz and VBW to 100 KHz.
- The 20 dB bandwidth is defined as the total spectrum the power of which is higher than peak power minus 20 dB.

### 7.3 Test Setup Layout

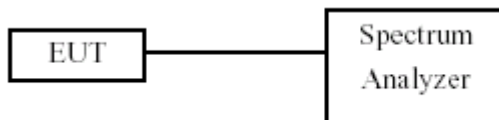

### 7.4 Test Result and Data

Test Date: Nov. 13, 2016

Temperature: 25°C

Atmospheric pressure: 1020 hPa

Humidity: 55%

1M

Channel	Frequency (MHz)	20dB Bandwidth (MHz)	2/3 of 20dB Bandwidth (MHz)
00	2402	0.864	0.576
39	2441	0.863	0.575
78	2480	0.850	0.567

2M

Channel	Frequency (MHz)	20dB Bandwidth (MHz)	2/3 of 20dB Bandwidth (MHz)
00	2402	1.219	0.813
39	2441	1.224	0.816
78	2480	1.203	0.802

3M

Channel	Frequency (MHz)	20dB Bandwidth (MHz)	2/3 of 20dB Bandwidth (MHz)
00	2402	1.204	0.803
39	2441	1.213	0.809
78	2480	1.208	0.805





Modulation Standard: GFSK (1Mbps)  
Channel: 00

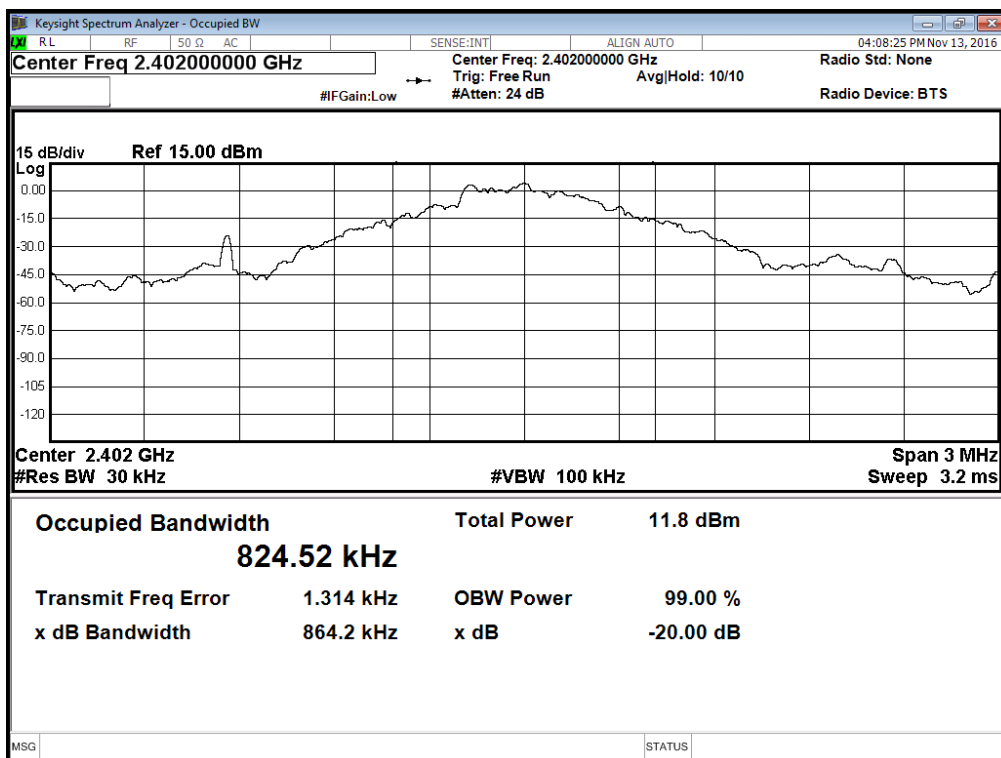

Modulation Standard: GFSK (1Mbps)  
Channel: 39

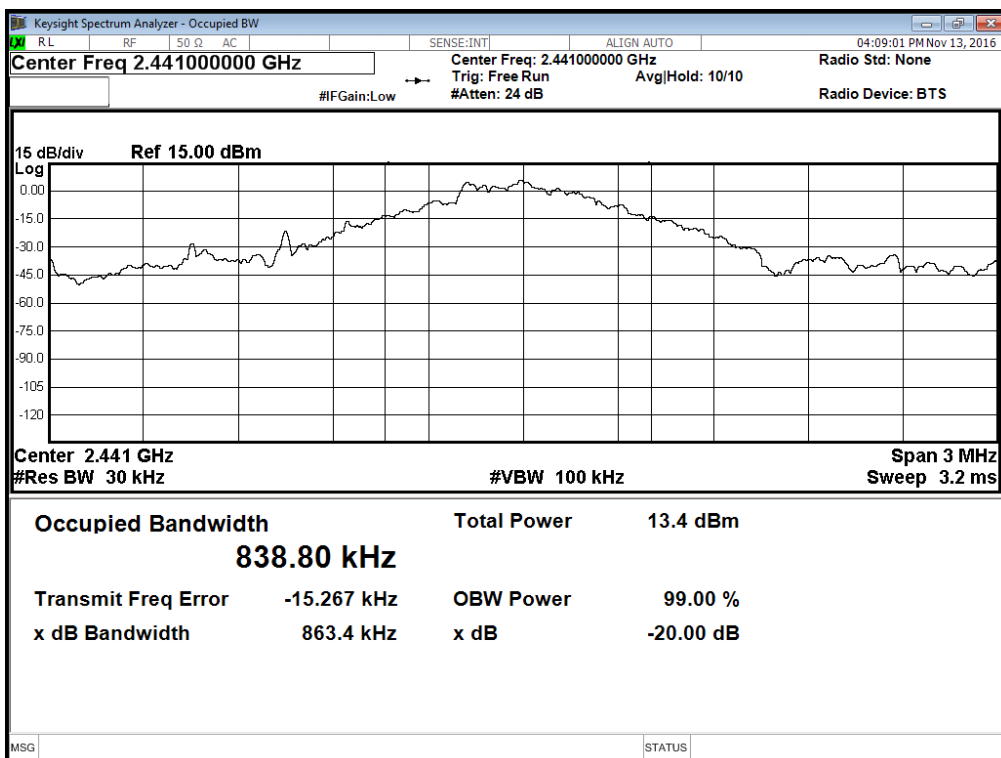



Modulation Standard: GFSK (1Mbps)  
Channel: 78

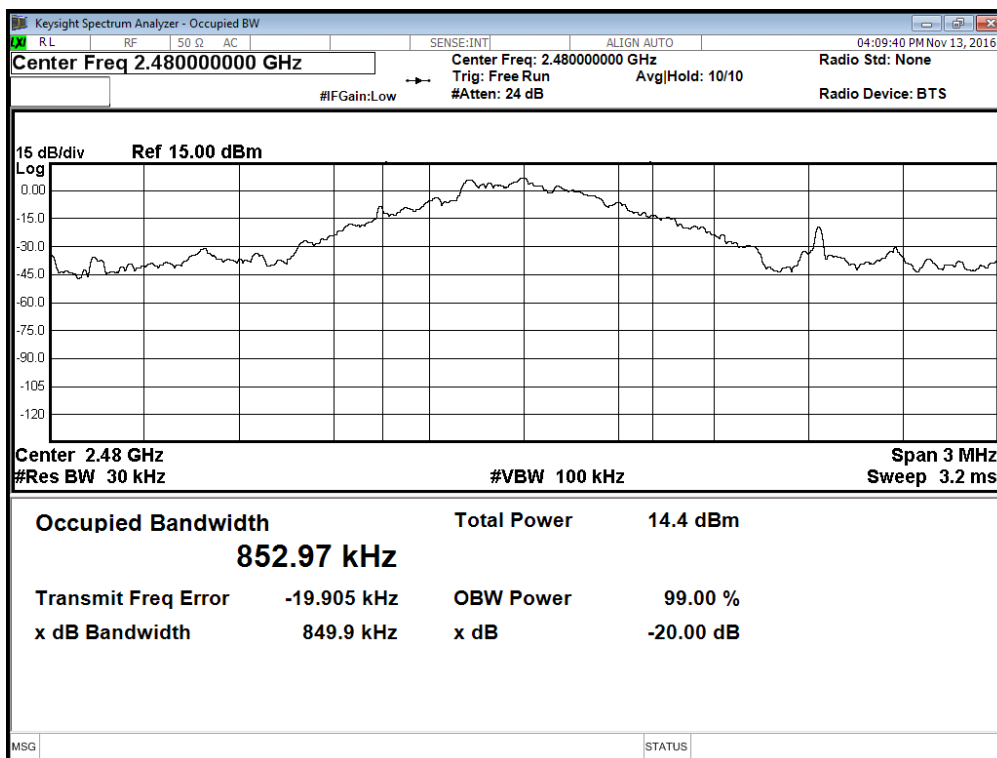

Modulation Standard:  $\pi/4$  DQPSK (2Mbps)  
Channel: 00

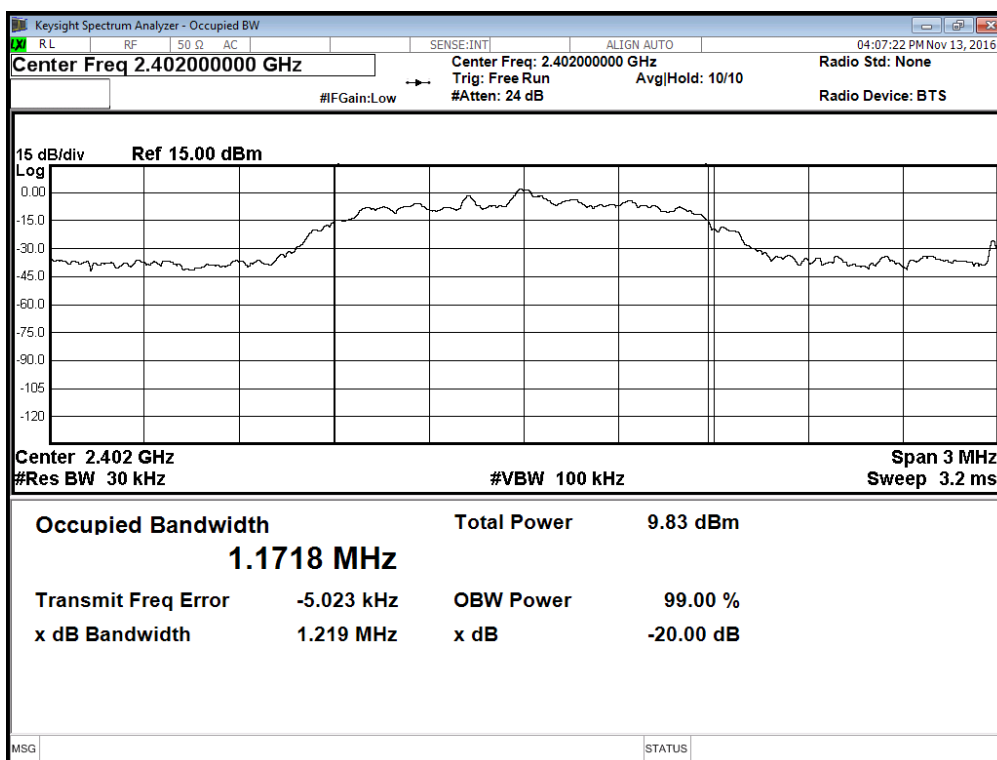



Modulation Standard:  $\pi/4$  DQPSK (2Mbps)  
Channel: 39

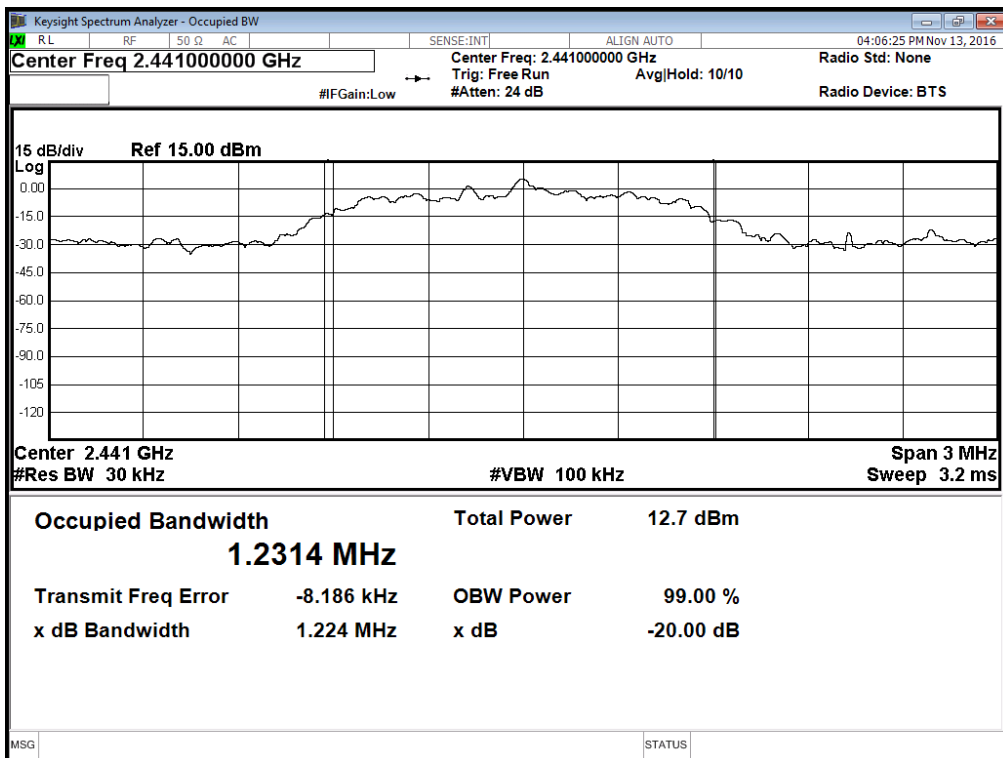

Modulation Standard:  $\pi/4$  DQPSK (2Mbps)  
Channel: 78

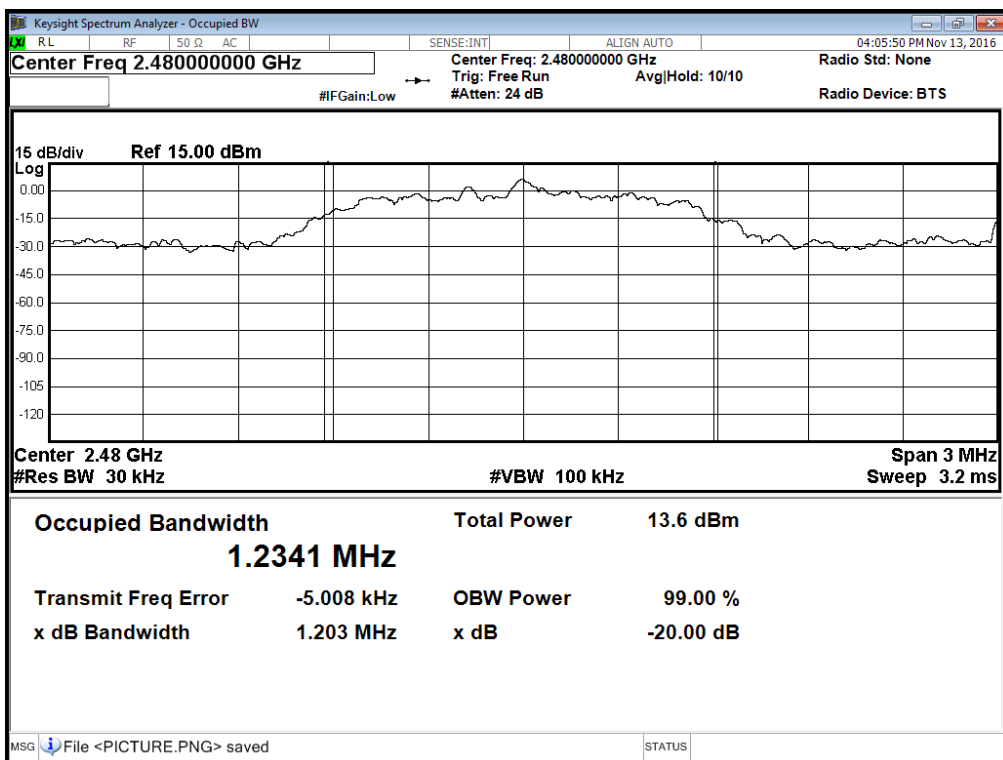



Modulation Standard: 8DPSK (3Mbps)  
Channel: 00

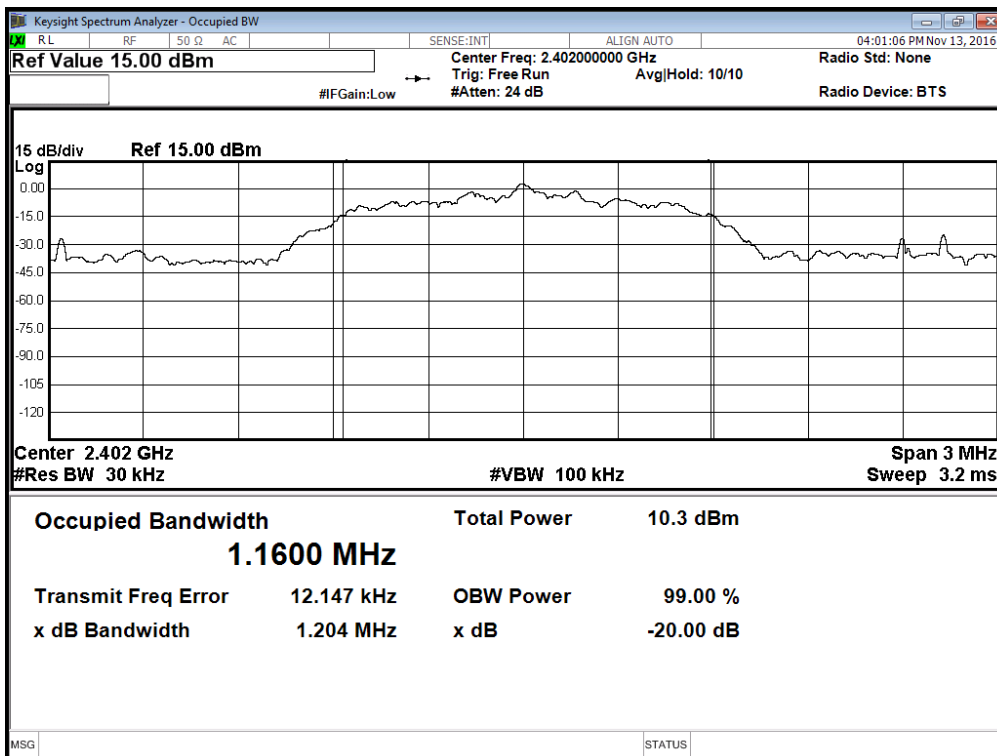

Modulation Standard: 8DPSK (3Mbps)  
Channel: 39

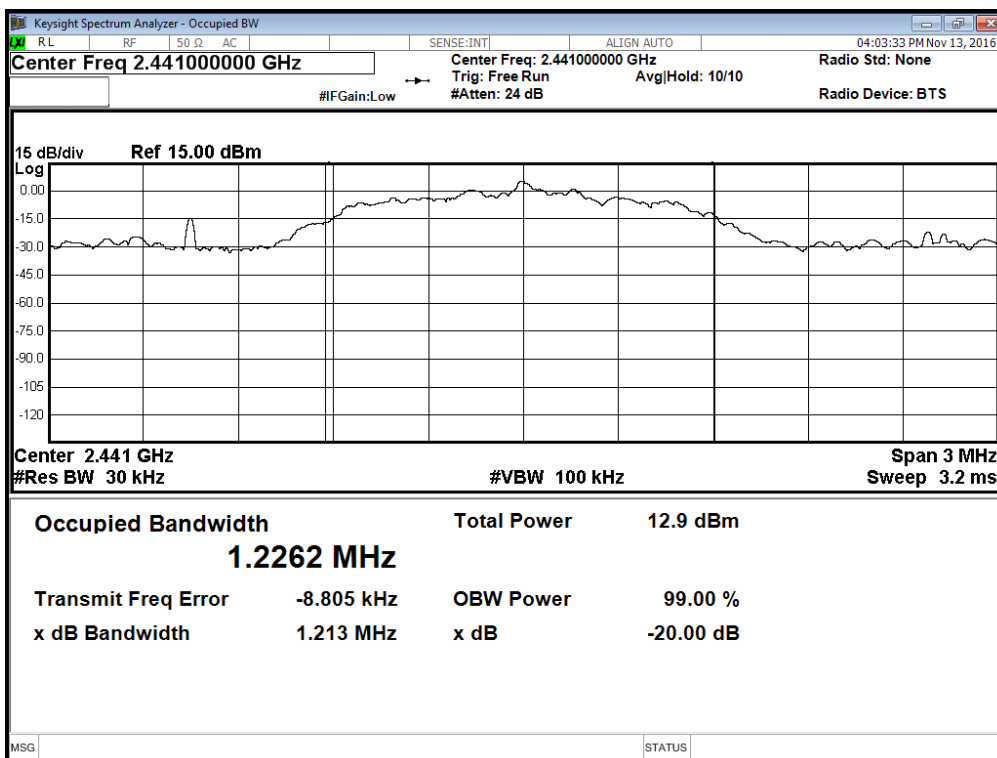



Modulation Standard: 8DPSK (3Mbps)  
Channel: 78

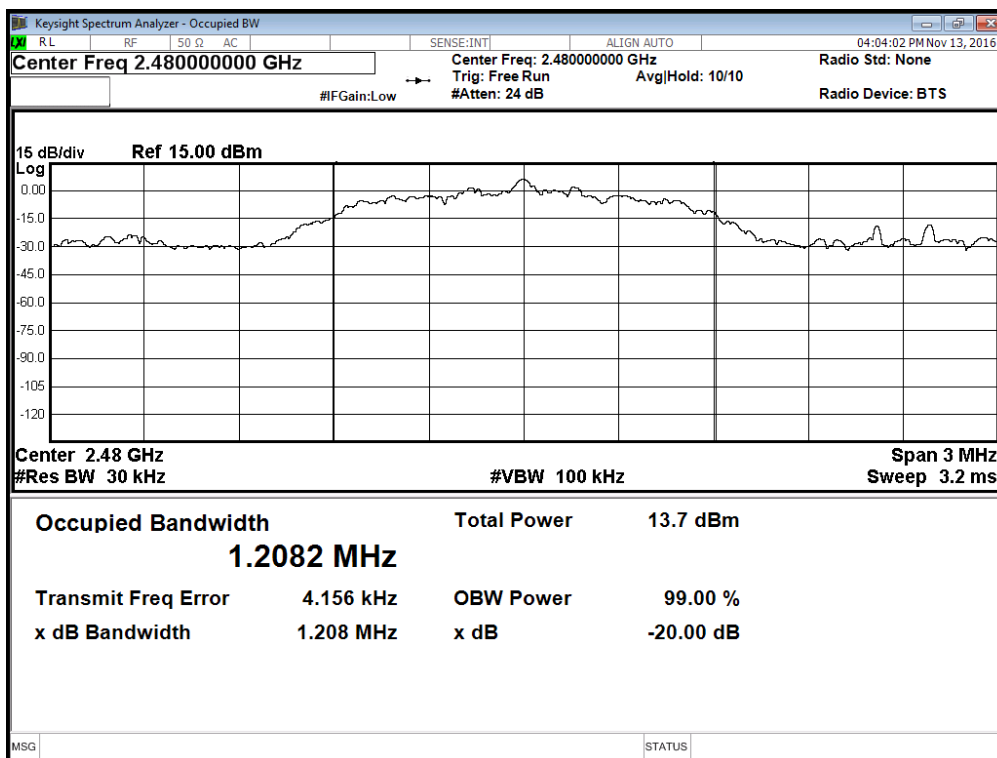



## 8. Frequencies Separation

### 8.1 Test Limit

Frequency hopping systems shall have hopping channel carrier frequencies separated by a minimum of 25 kHz or the 20 dB bandwidth of the hopping channel, whichever is greater.

### 8.2 Test Procedures

- The transmitter output was connected to the spectrum analyzer.
- Set RBW of spectrum analyzer to 30 KHz and VBW to 100 KHz.
- By using the MaxHold function record the separation of two adjacent channels.
- Measure the frequency difference of these two adjacent channels.

### 8.3 Test Setup Layout

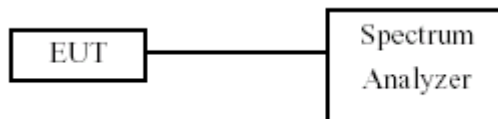

### 8.4 Test Result and Data

Test Date: Nov. 13, 2016

Temperature: 25°C

Atmospheric pressure: 1020 hPa

Humidity: 55%

1M

Frequency (MHz)	Channel Separation (MHz)	Limit (MHz)	2/3 of 20dB Bandwidth (MHz)
2402	1.000	$\geq$ 2/3 of 20dB Bandwidth	0.576
2441	1.000	$\geq$ 2/3 of 20dB Bandwidth	0.575
2480	1.000	$\geq$ 2/3 of 20dB Bandwidth	0.567

2M

Frequency (MHz)	Channel Separation (MHz)	Limit (MHz)	2/3 of 20dB Bandwidth (MHz)
2402	1.000	$\geq$ 2/3 of 20dB Bandwidth	0.813
2441	1.000	$\geq$ 2/3 of 20dB Bandwidth	0.816
2480	1.000	$\geq$ 2/3 of 20dB Bandwidth	0.802

3M

Frequency (MHz)	Channel Separation (MHz)	Limit (MHz)	2/3 of 20dB Bandwidth (MHz)
2402	1.000	$\geq$ 2/3 of 20dB Bandwidth	0.803
2441	1.000	$\geq$ 2/3 of 20dB Bandwidth	0.809
2480	1.000	$\geq$ 2/3 of 20dB Bandwidth	0.805



Modulation Standard: GFSK (1Mbps)

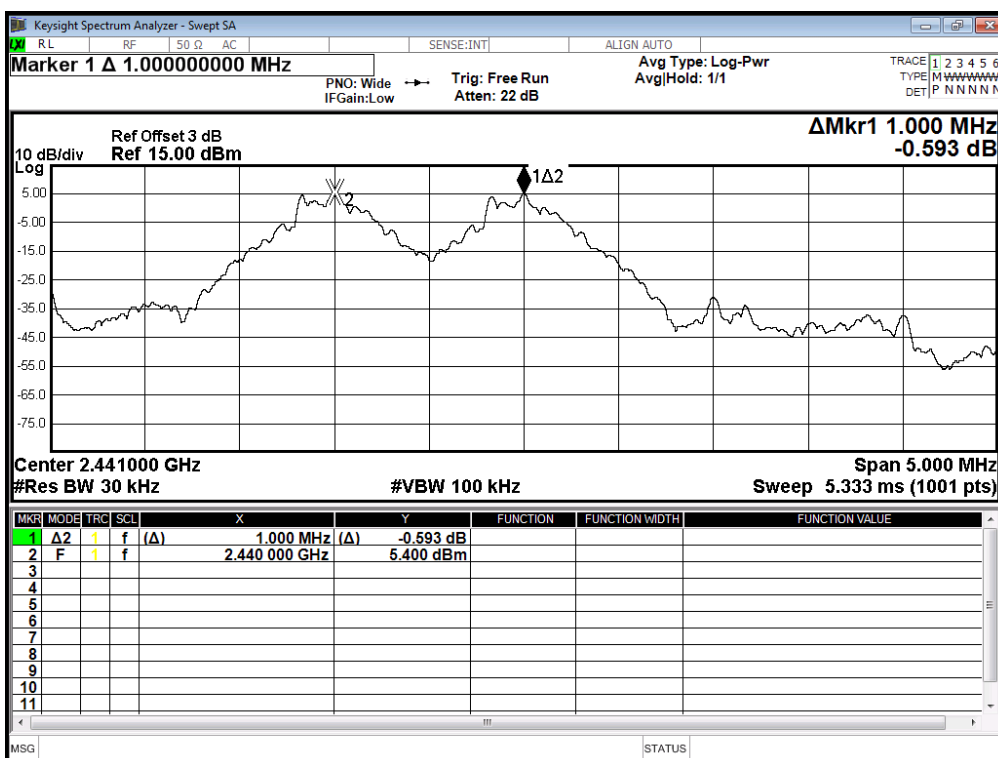

Modulation Standard:  $\pi/4$  DQPSK (2Mbps)

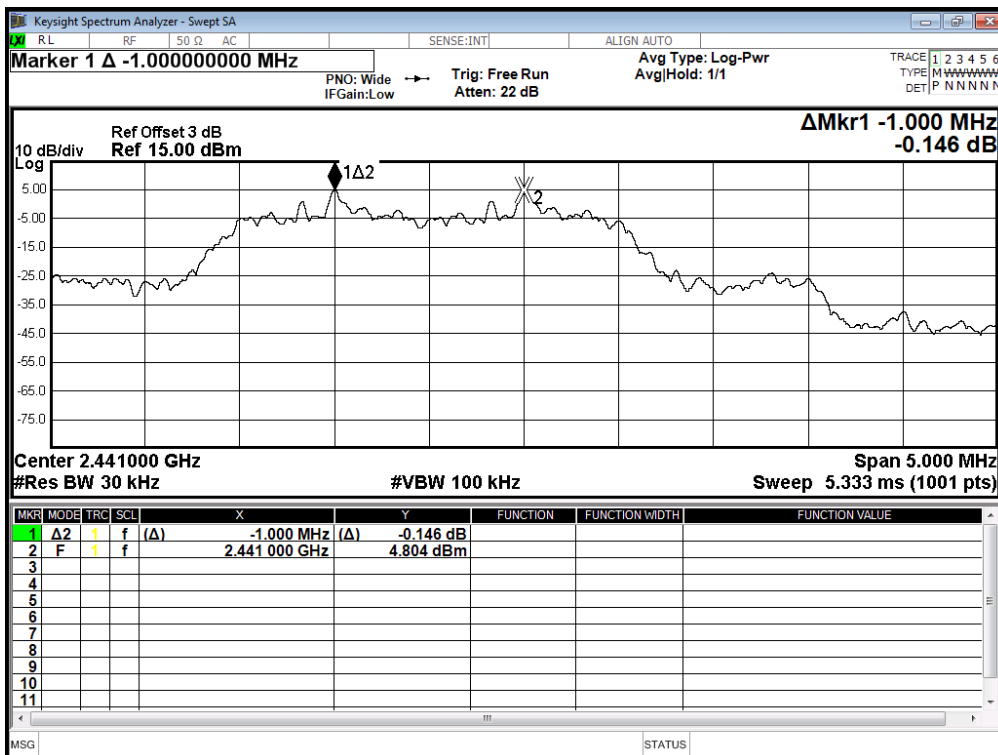



Modulation Standard: 8DPSK(3Mbps)

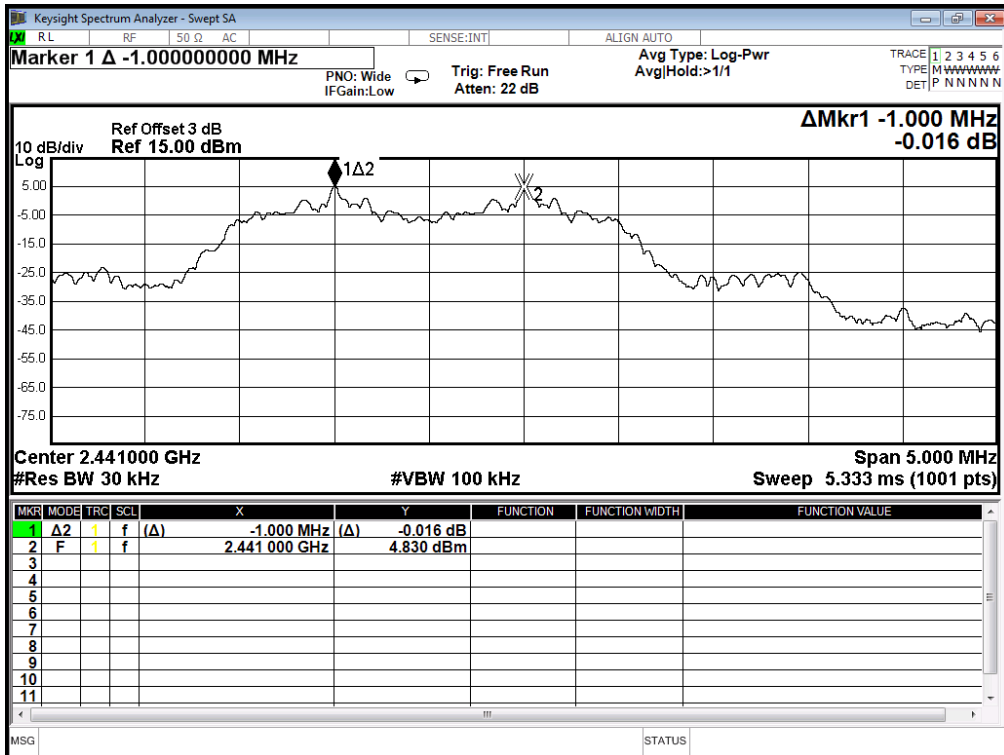





## 9. Dwell Time on each channel

### 9.1 Test Limit

The average time of occupancy on any channel shall not be greater than 0.4 seconds within a period of 0.4 seconds multiplied by the number of hopping channels employed.

### 9.2 Test Procedures

1. The transmitter output was connected to the spectrum analyzer.
2. Adjust the center frequency to measure frequency, then set zero span mode.
2. Set RBW of spectrum analyzer to 1 MHz and VBW to 1 MHz.
4. Measure the time duration of one transmission on the measured frequency.

### 9.3 Test Setup Layout

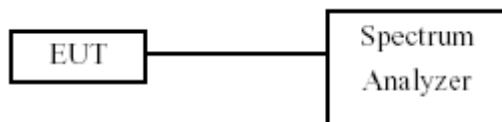



### 9.4 Test Result and Data

Test Date : Nov. 13, 2016      Temperature : 22C  
Atmospheric pressure : 1017 hPa      Humidity : 60 %  
Test Period = 0.4 (second/ channel) x 79 Channel = 31.6 sec

Modulation Standard: GFSK(1Mbps)

DH 1

$$0.423 * (1600/2)/79 * 31.6 = 135.36(\text{ms})$$

Pulse Time (ms)	Total of Dwell (ms)	Period Time (s)	Limit (ms)	Result
0.423	135.36	31.6	400	PASS

DH 3

$$1.686 * (1600/4)/79 * 31.6 = 269.76(\text{ms})$$

Pulse Time (ms)	Total of Dwell (ms)	Period Time (s)	Limit (ms)	Result
1.686	269.76	31.6	400	PASS

DH 5

$$2.928 * (1600/6)/79 * 31.6 = 312.32(\text{ms})$$

Pulse Time (ms)	Total of Dwell (ms)	Period Time (s)	Limit (ms)	Result
2.928	312.32	31.6	400	PASS



Modulation Standard:  $\pi/4$  DQPSK(2Mbps)

DH 1

$$0.432 * (1600/2)/79 * 31.6 = 138.24(\text{ms})$$

Pulse Time (ms)	Total of Dwell (ms)	Period Time (s)	Limit (ms)	Result
0.432	138.24	31.6	400	PASS

DH 3

$$1.692 * (1600/4)/79 * 31.6 = 270.72(\text{ms})$$

Pulse Time (ms)	Total of Dwell (ms)	Period Time (s)	Limit (ms)	Result
1.692	270.72	31.6	400	PASS

DH 5

$$2.940 * (1600/6)/79 * 31.6 = 313.60(\text{ms})$$

Pulse Time (ms)	Total of Dwell (ms)	Period Time (s)	Limit (ms)	Result
2.940	313.60	31.6	400	PASS

Modulation Standard: 8DPSK(3Mbps)

DH 1

$$0.432 * (1600/2)/79 * 31.6 = 138.24(\text{ms})$$

Pulse Time (ms)	Total of Dwell (ms)	Period Time (s)	Limit (ms)	Result
0.432	138.24	31.6	400	PASS

DH 3

$$1.692 * (1600/4)/79 * 31.6 = 270.72(\text{ms})$$

Pulse Time (ms)	Total of Dwell (ms)	Period Time (s)	Limit (ms)	Result
1.692	270.72	31.6	400	PASS

DH 5

$$2.952 * (1600/6)/79 * 31.6 = 314.88(\text{ms})$$

Pulse Time (ms)	Total of Dwell (ms)	Period Time (s)	Limit (ms)	Result
2.952	314.88	31.6	400	PASS



Modulation Standard: GFSK (1Mbps)

DH1

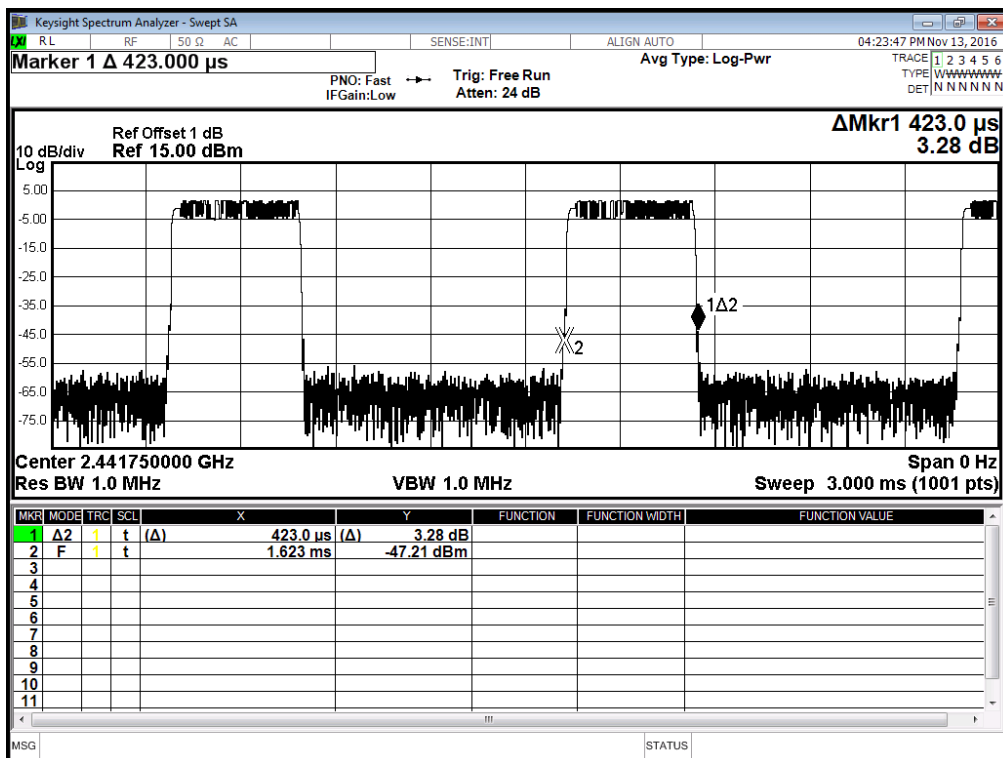

Modulation Standard: GFSK (1Mbps)

DH3

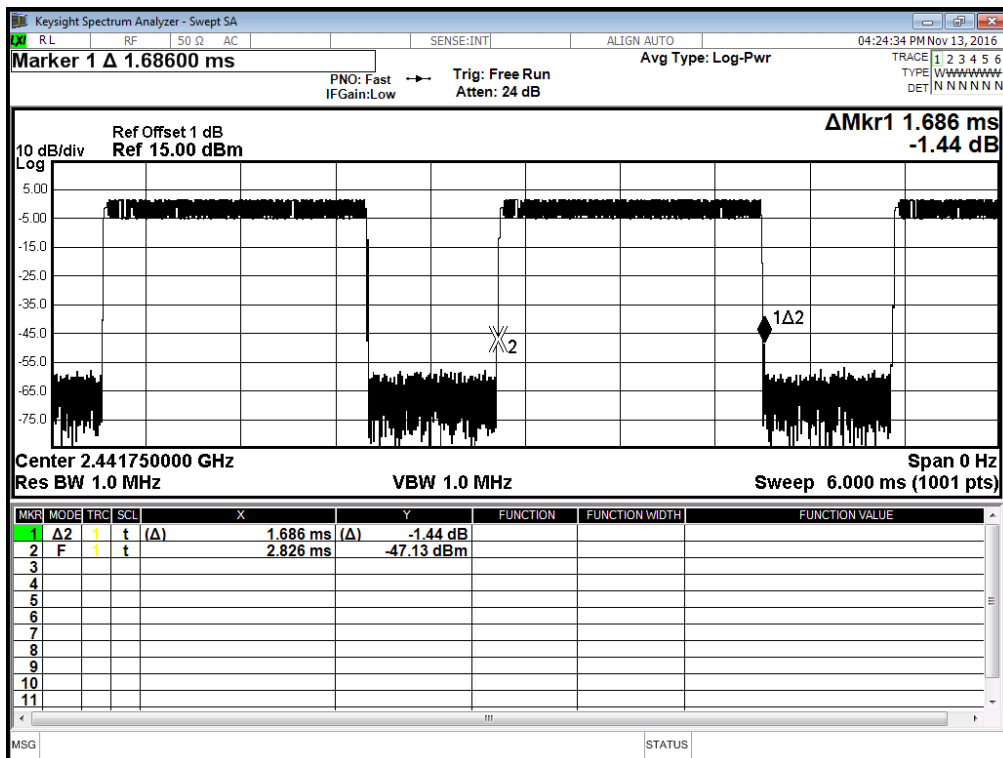



Modulation Standard: GFSK (1Mbps)

DH5

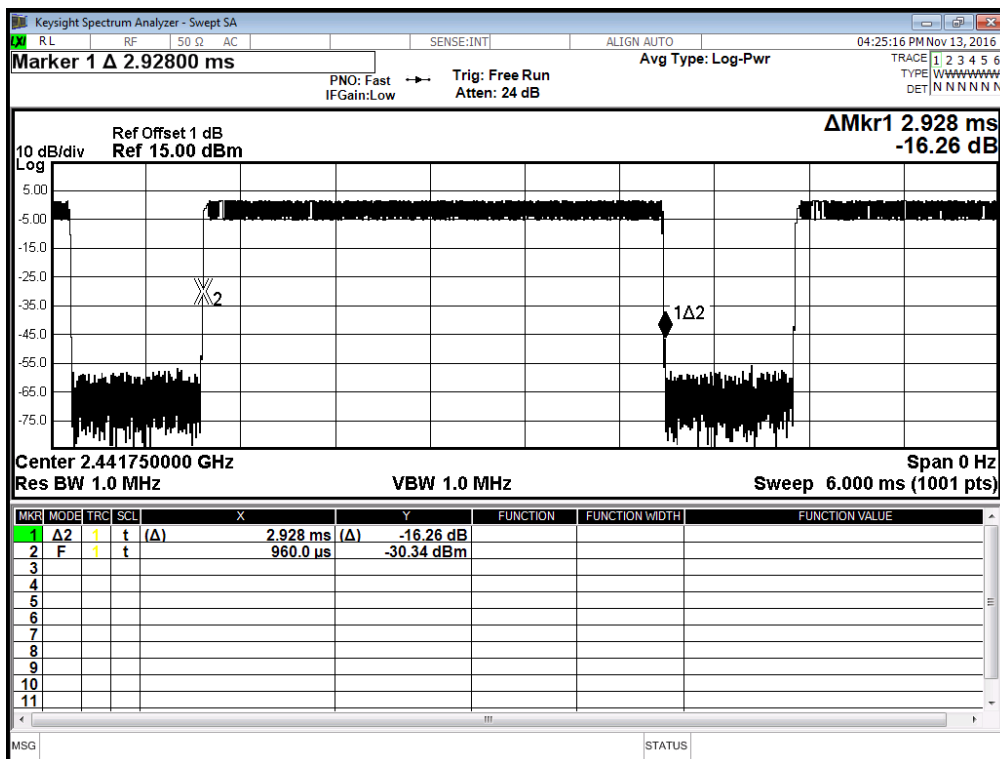

Modulation Standard:  $\pi/4$  DQPSK (2Mbps)

DH1

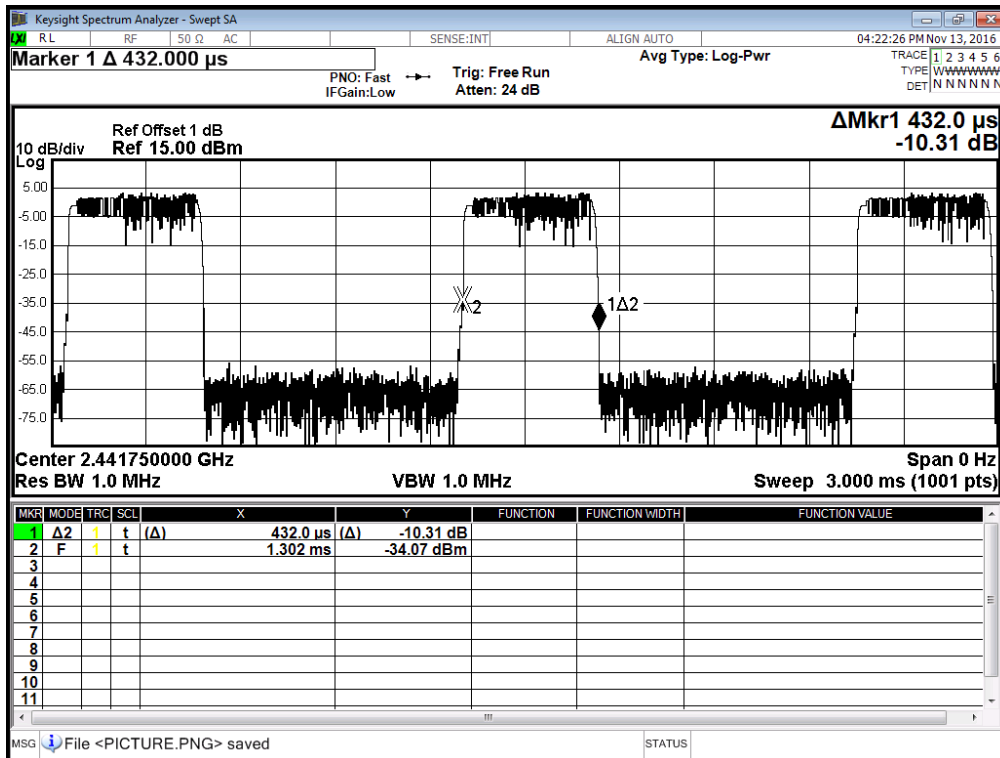



Modulation Standard:  $\pi/4$  DQPSK (2Mbps)  
DH3

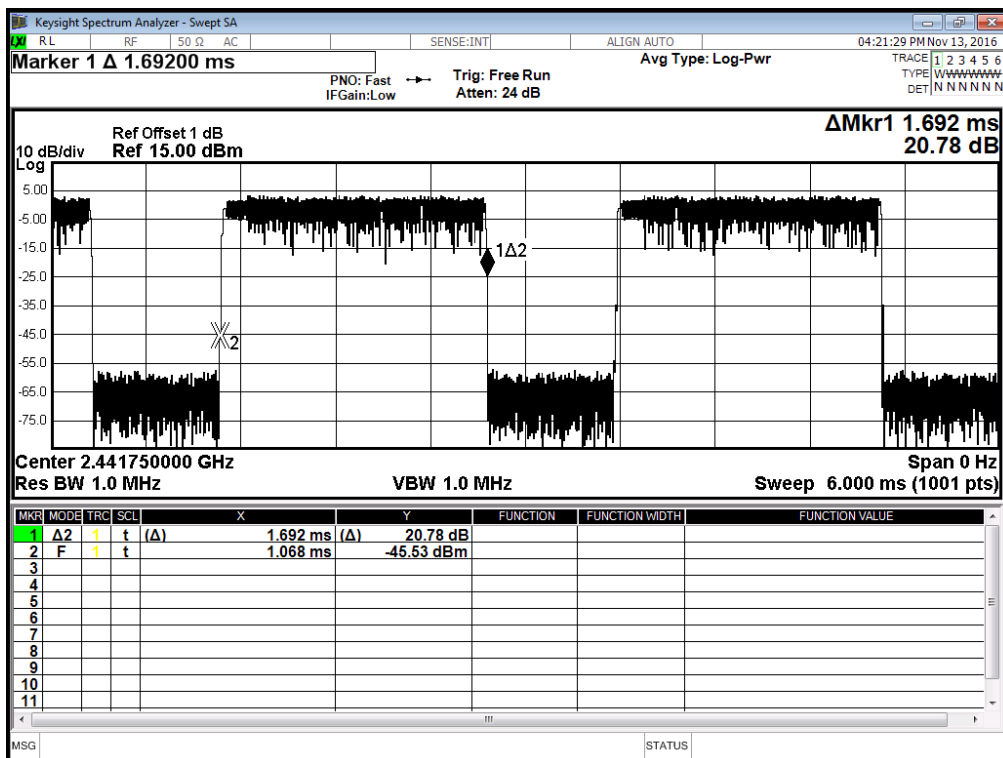

Modulation Standard:  $\pi/4$  DQPSK (2Mbps)  
DH5

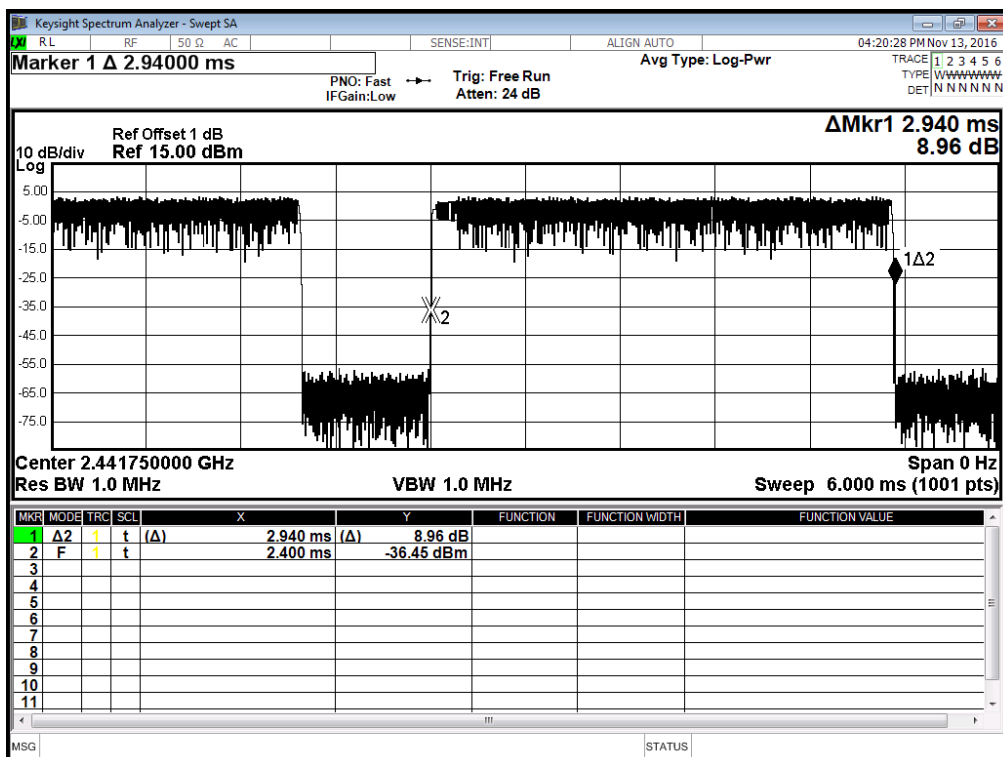



Modulation Standard: 8DPSK (3Mbps)

DH1

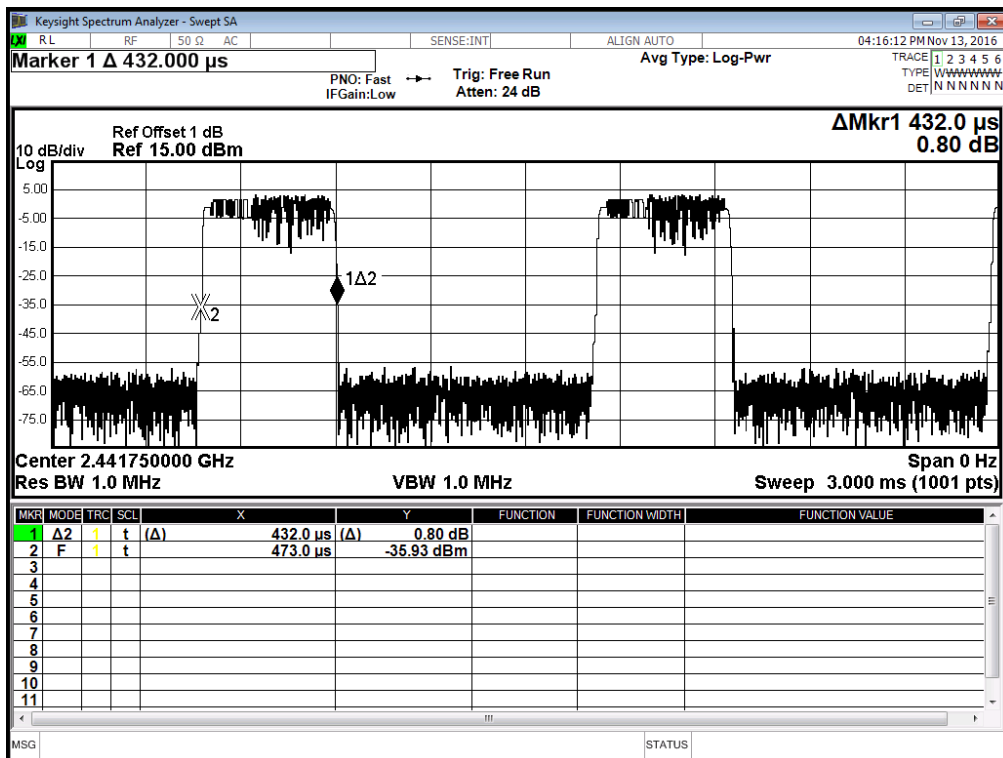

Modulation Standard: 8DPSK (3Mbps)

DH3

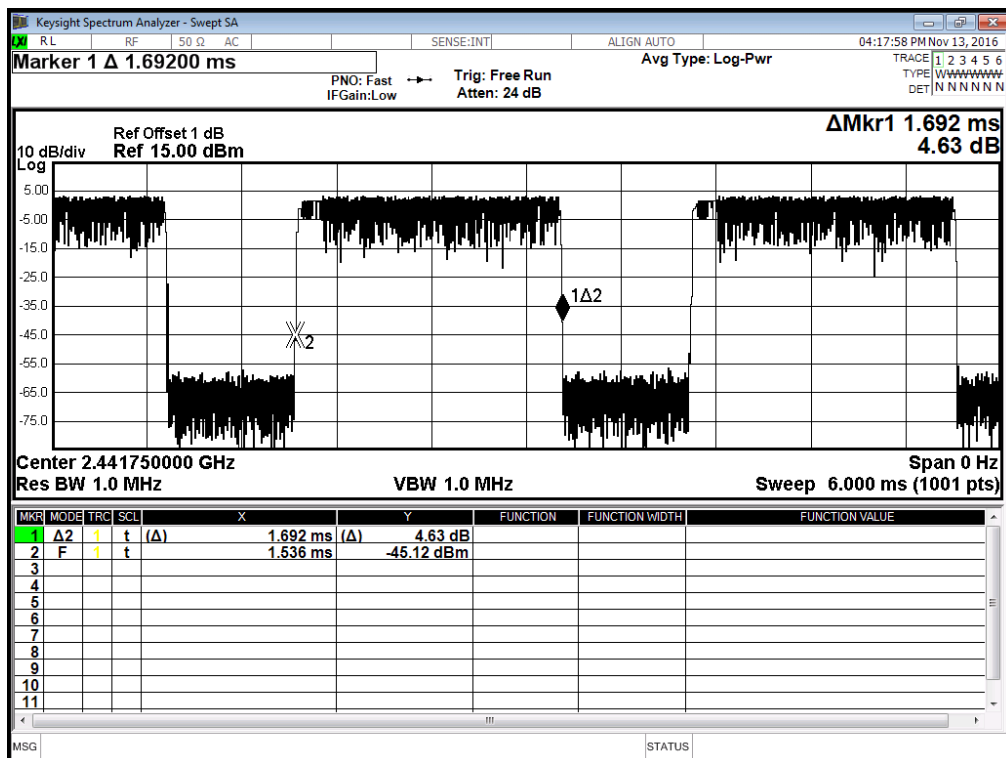



Modulation Standard: 8DPSK (3Mbps)  
DH5

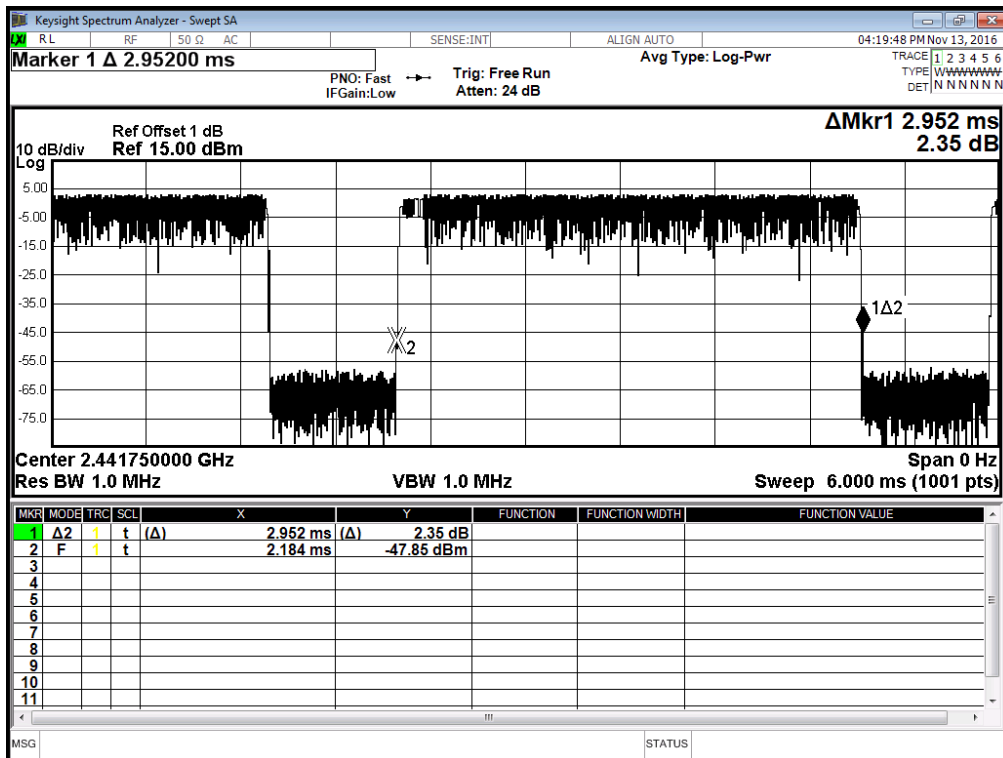





## 10. Number of Hopping Channels

### 10.1 Test Limit

Frequency hopping systems in the 2400 ~ 2483.5 MHz band shall use at least 15 channels.

### 10.2 Test Procedures

- a. The transmitter output was connected to the spectrum analyzer.
- b. 2. Set RBW of spectrum analyzer to 300 KHz and VBW to 300 KHz.
- c. 3. Set the MaxHold function, and then keep the EUT in hopping mode. Record all the signals from each channel until each one has been record.

### 10.3 Test Setup Layout

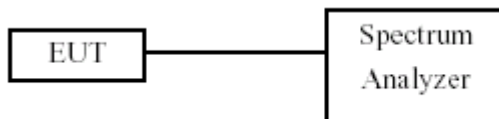

### 10.4 Test Result and Data

Test Date: Nov. 13, 2016

Temperature: 25°C

Atmospheric pressure: 1020 hPa

Humidity: 55%

Modulation Standard: GFSK (1Mbps)

Number of hopping channels:	79	Channels
-----------------------------	----	----------

Modulation Standard:  $\pi/4$  DQPSK (2Mbps)

Number of hopping channels:	79	Channels
-----------------------------	----	----------

Modulation Standard: 8DPSK (3Mbps)

Number of hopping channels:	79	Channels
-----------------------------	----	----------



Modulation Standard: GFSK (1Mbps)

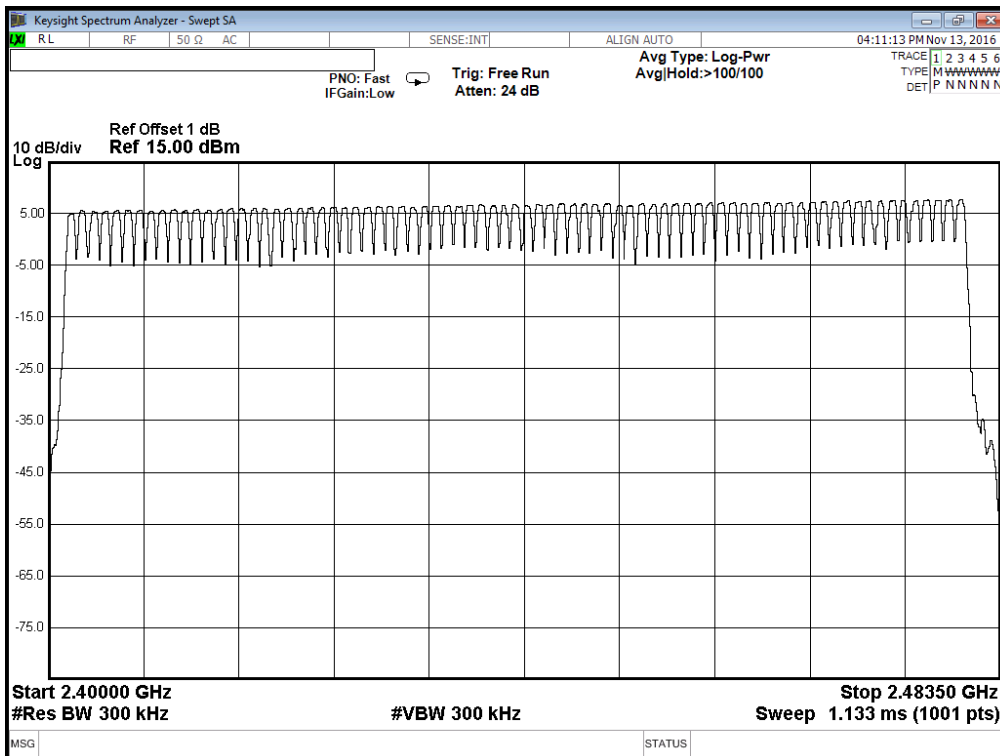

Modulation Standard:  $\pi/4$  DQPSK (2Mbps)

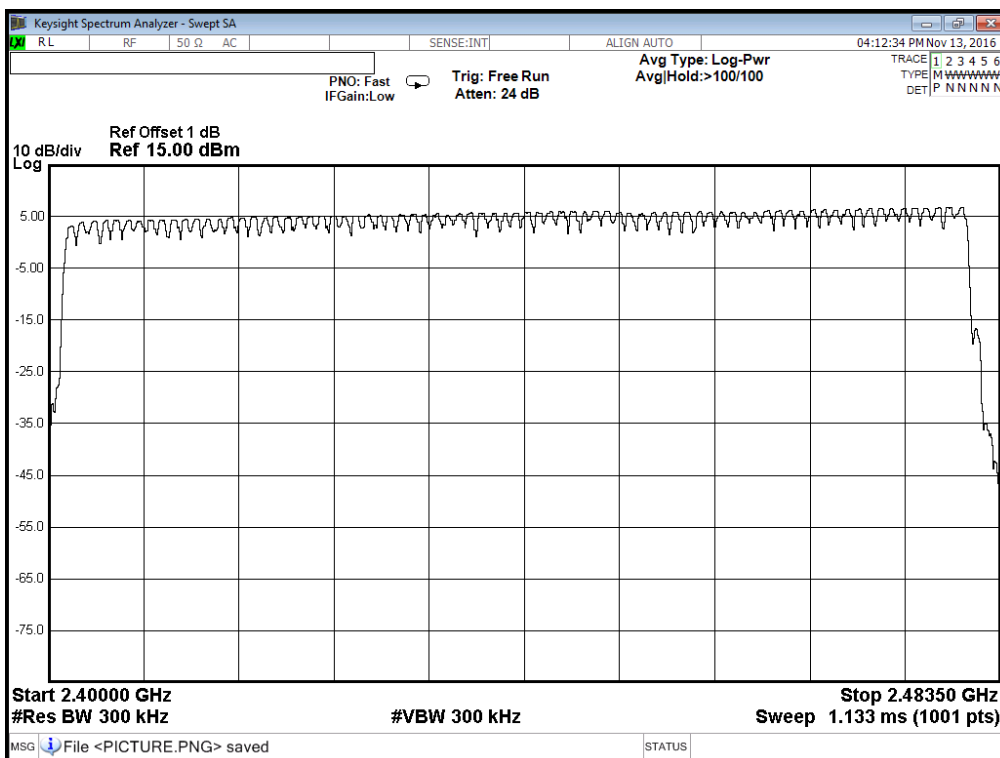



Modulation Standard: 8DPSK (3Mbps)

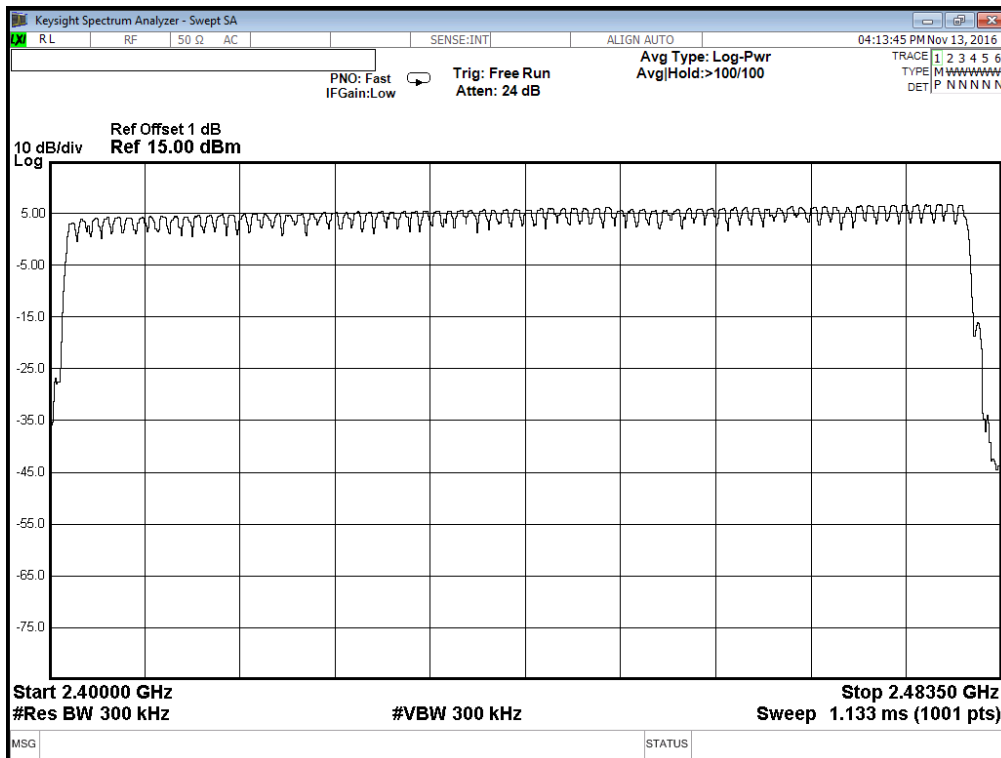



## 11. Maximum Peak Output Power

### 11.1 Test Limit

The Maximum Peak Output Power Measurement is 30dBm.

### 11.2 Test Procedures

The antenna port( RF output )of the EUT was connected to the input( RF input )of a power meter. Power was read directly from the meter and cable loss connection was added to the reading to obtain power at the EUT antenna terminal. The EUT Output Power was set to maximum to produce the worse case test result.

### 11.3 Test Setup Layout

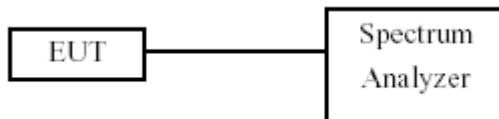

### 11.4 Test Result and Data

Test Date:Nov. 13, 2016

Temperature: 25°C

Atmospheric pressure: 1020 hPa

Humidity: 55%

Modulation Type	Channel	Frequency (MHz)	Peak Power Output (dBm)	Peak Power Output (mW)
GFSK (1Mbps)	00	2402	5.026	3.181
	39	2441	6.691	4.668
	78	2480	7.538	5.673
$\pi/4$ DQPSK (2Mbps)	00	2402	4.069	2.552
	39	2441	6.134	4.106
	78	2480	7.070	5.093
8DPSK (3Mbps)	00	2402	4.288	2.684
	39	2441	6.253	4.220
	78	2480	7.230	5.284



Modulation Standard: GFSK (1Mbps)

Channel: 00

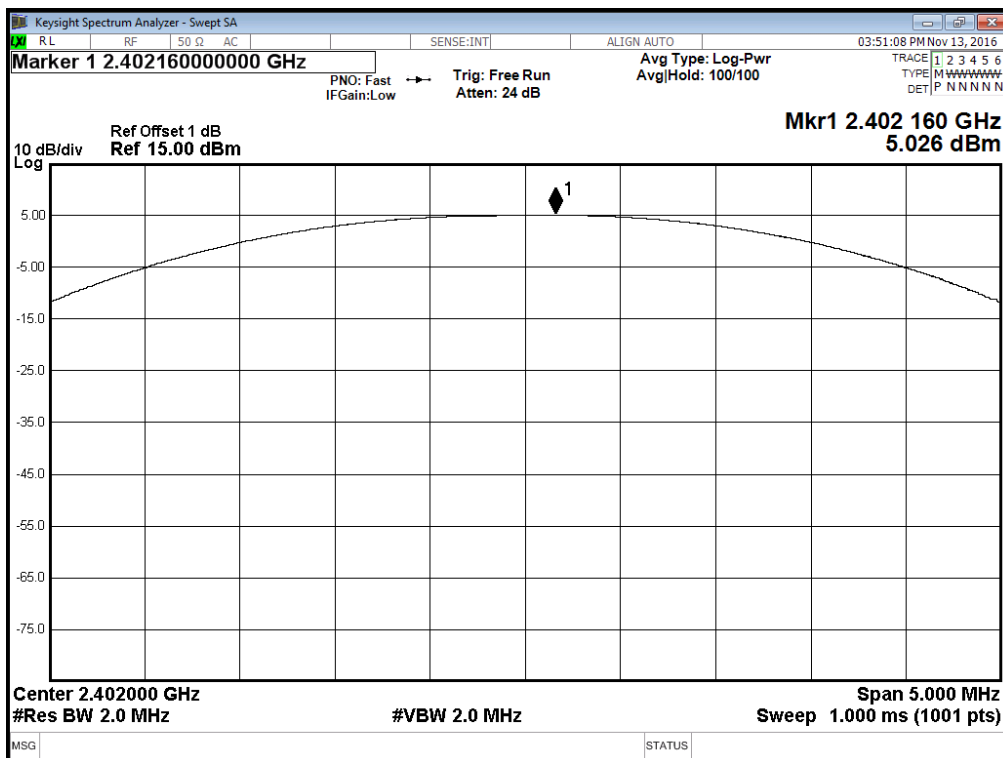

Modulation Standard: GFSK (1Mbps)

Channel: 39

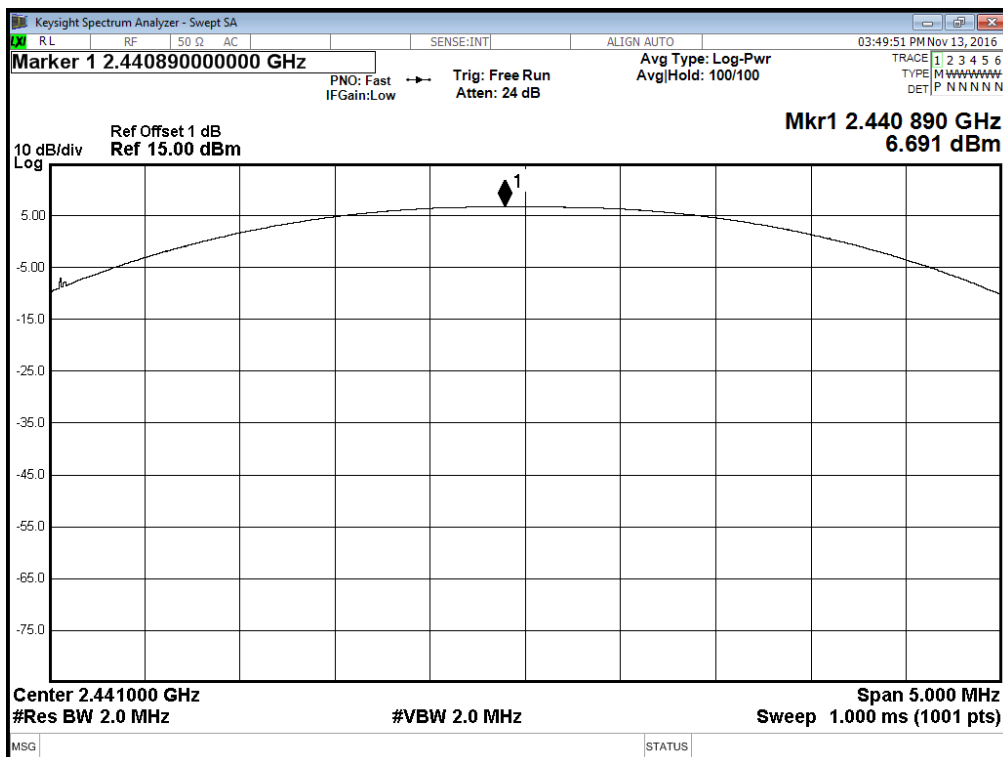



Modulation Standard: GFSK (1Mbps)

Channel: 78

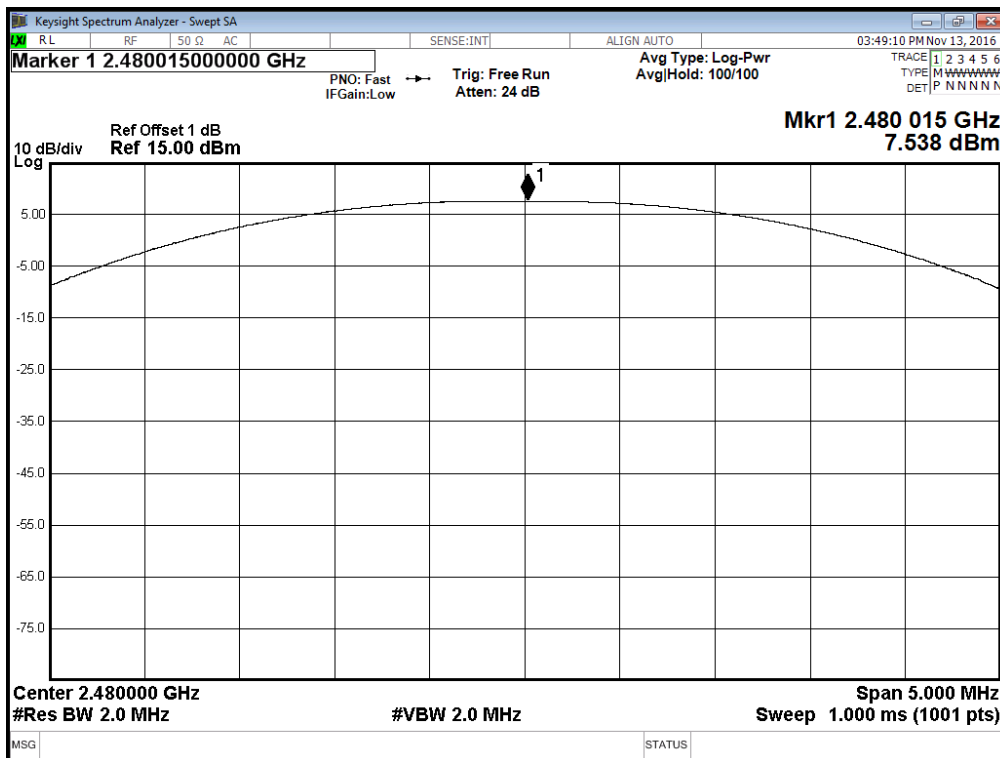

Modulation Standard:  $\pi/4$  DQPSK (2Mbps)

Channel: 00

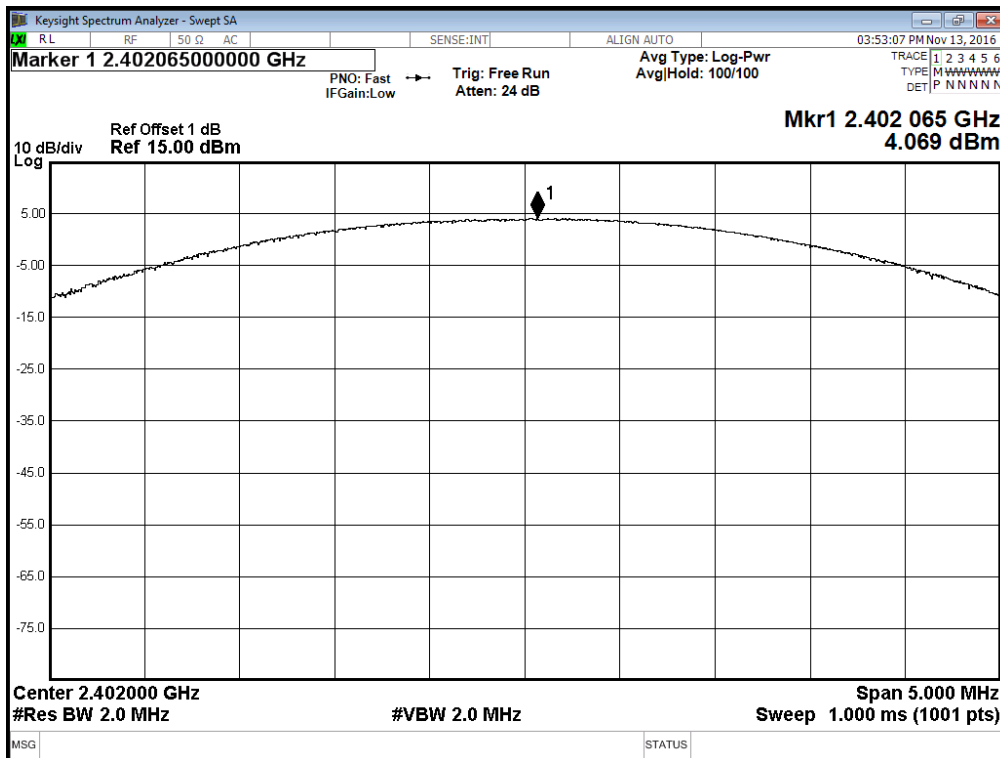



Modulation Standard:  $\pi/4$  DQPSK (2Mbps)

Channel: 39

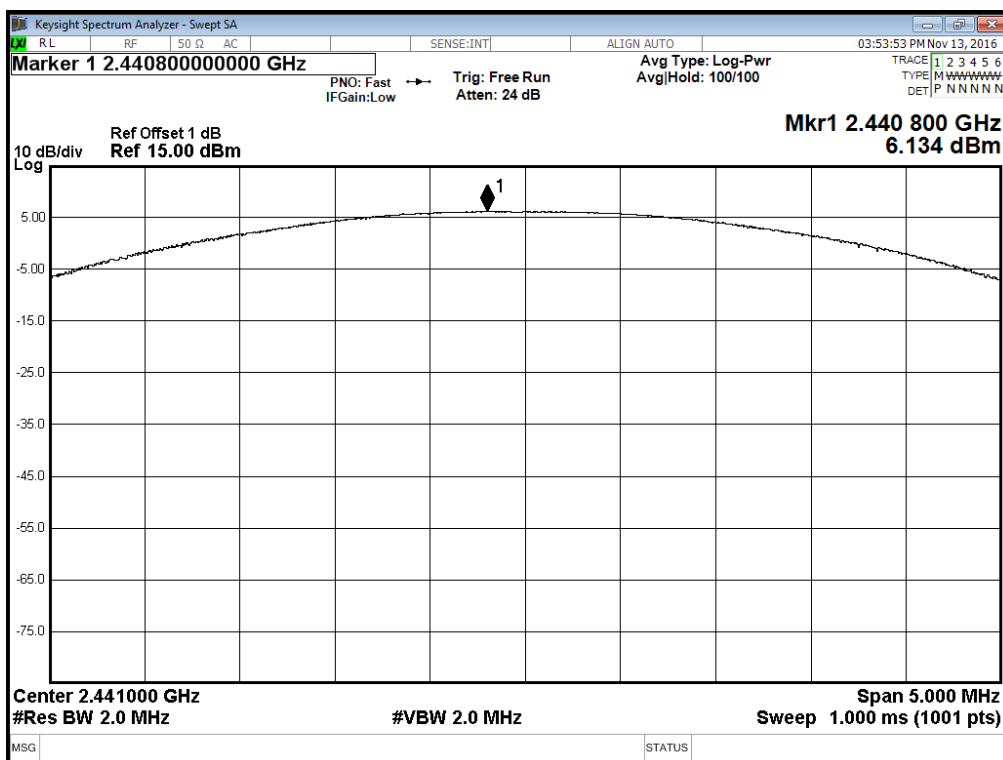

Modulation Standard:  $\pi/4$  DQPSK (2Mbps)

Channel: 78

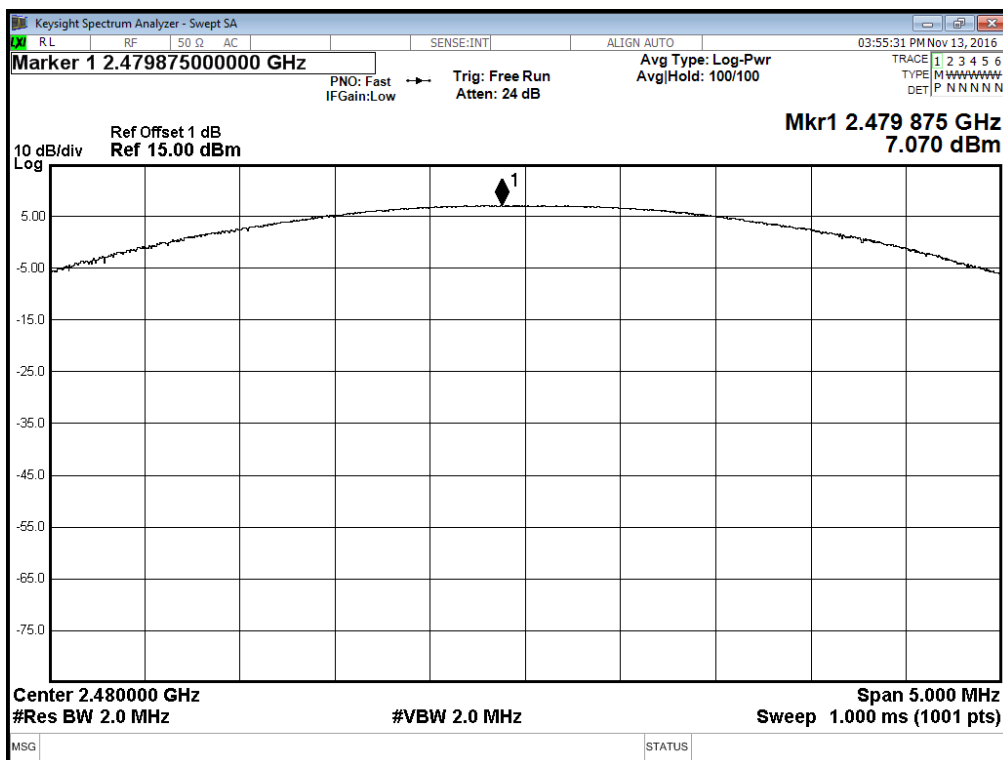



Modulation Standard: 8DPSK (3Mbps)

Channel: 00

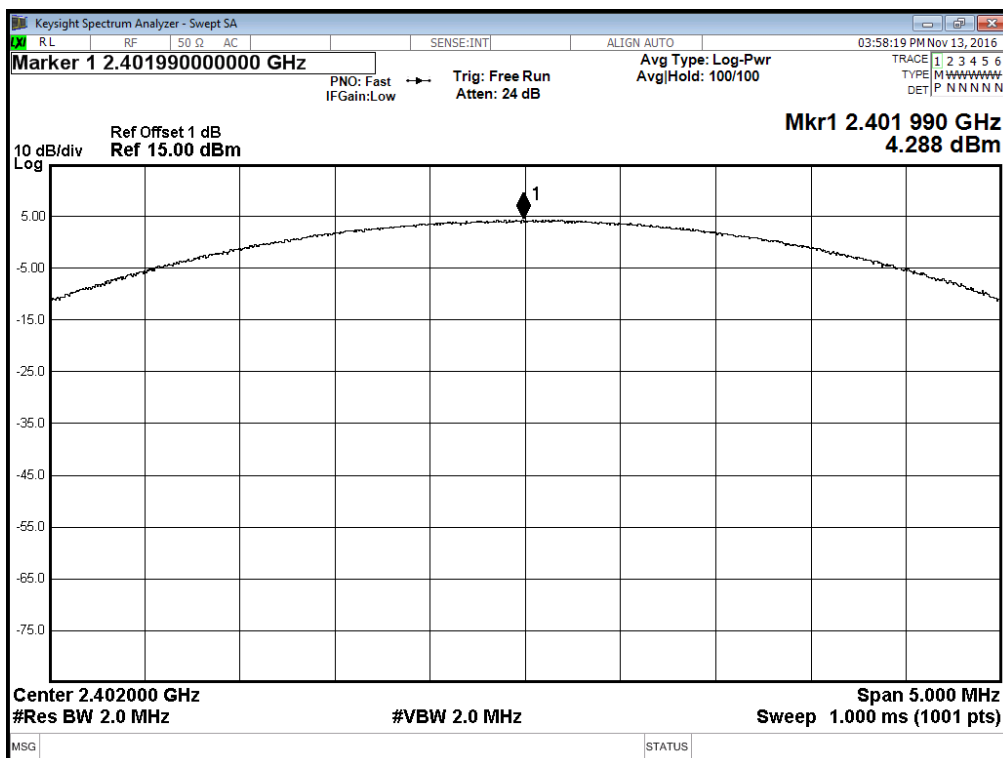

Modulation Standard: 8DPSK (3Mbps)

Channel: 39

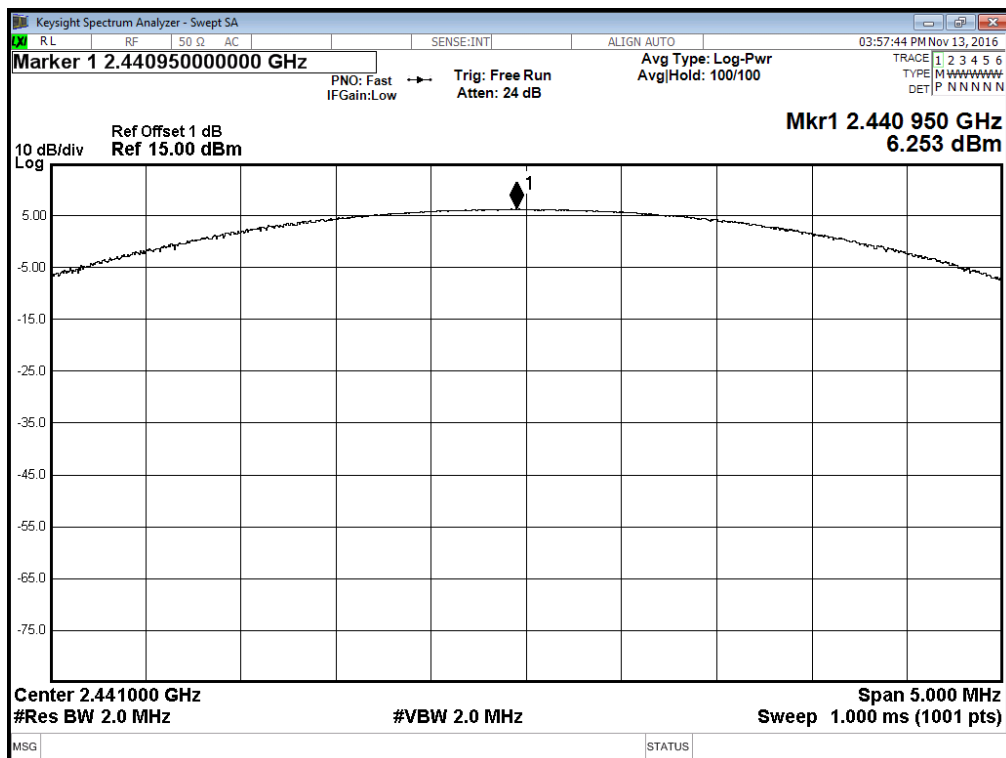





Modulation Standard: 8DPSK (3Mbps)

Channel: 78

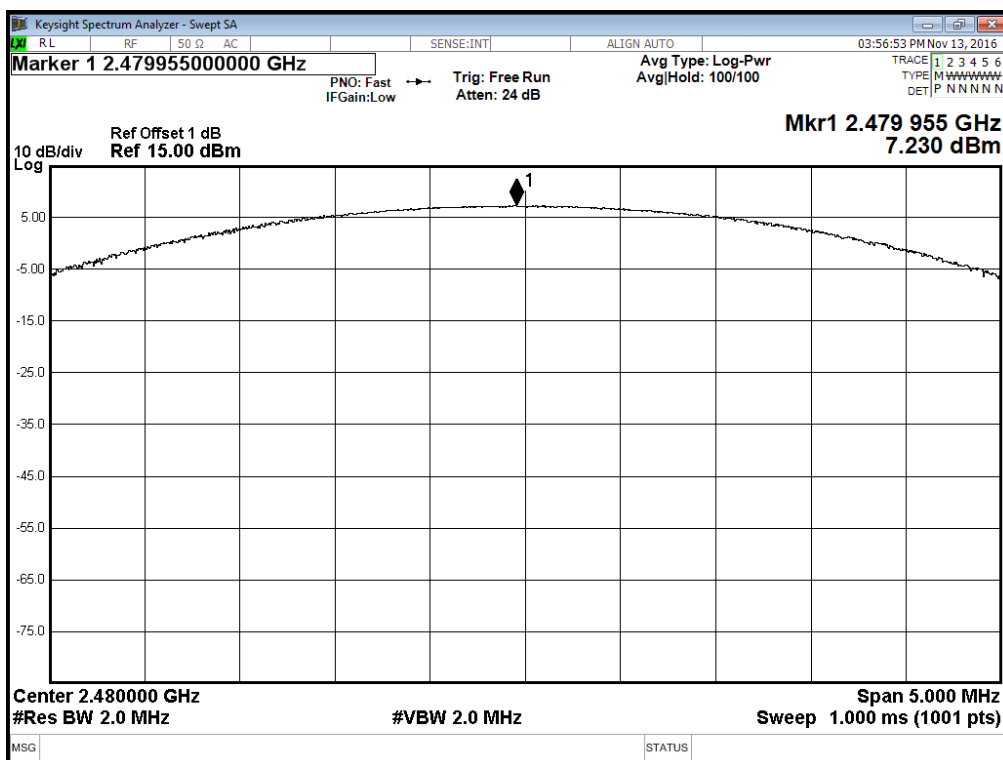



## 12. Band Edges Measurement

### 12.1 Test Limit

Below  $-20\text{dB}$  of the highest emission level of operating band (in 100kHz Resolution Bandwidth).

### 12.2 Test Procedure

- a. The transmitter output was connected to the spectrum analyzer via a low lose cable.
- b. Set both RBW and VBW of spectrum analyzer to 100 KHz with convenient frequency span including 100 KHz bandwidth from band edge.
- c. The band edges was measured and recorded.

### 12.3 Test Setup Layout

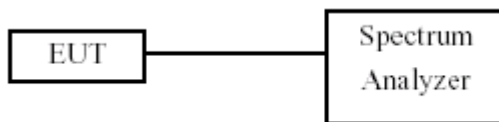



### 12.4 Test Result and Data

#### Single test

Modulation Standard: GFSK (1Mbps)

Channel: 00

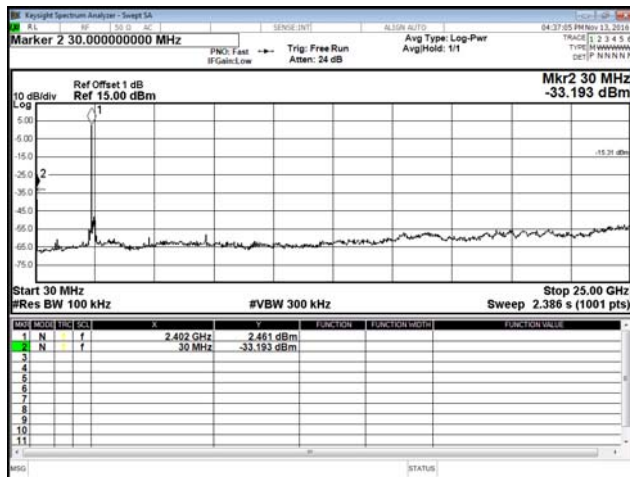
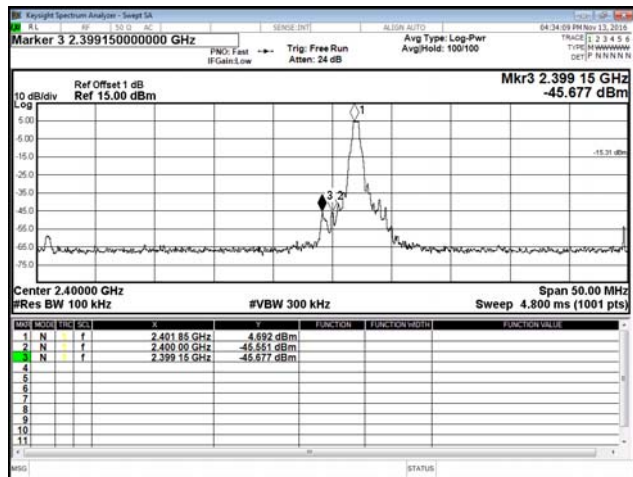

Modulation Standard: GFSK (1Mbps)

Channel: 78

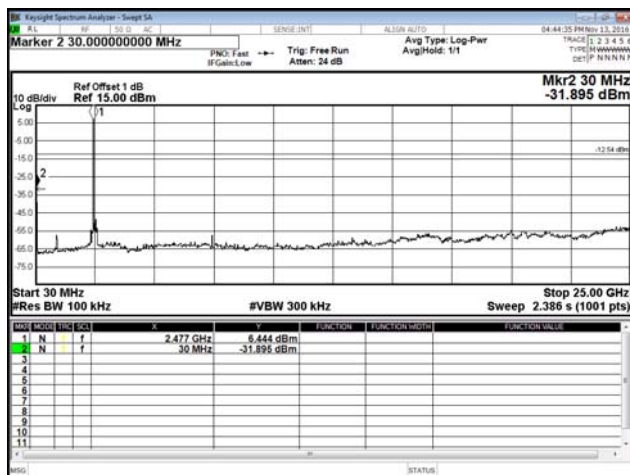

Modulation Standard:  $\pi/4$  DQPSK (2Mbps)

Channel: 00

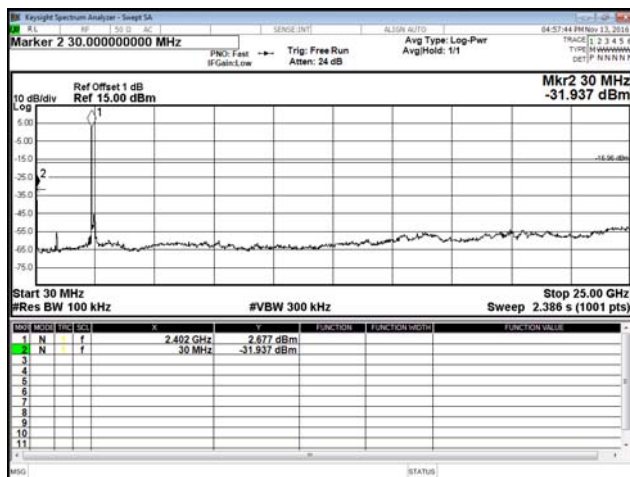
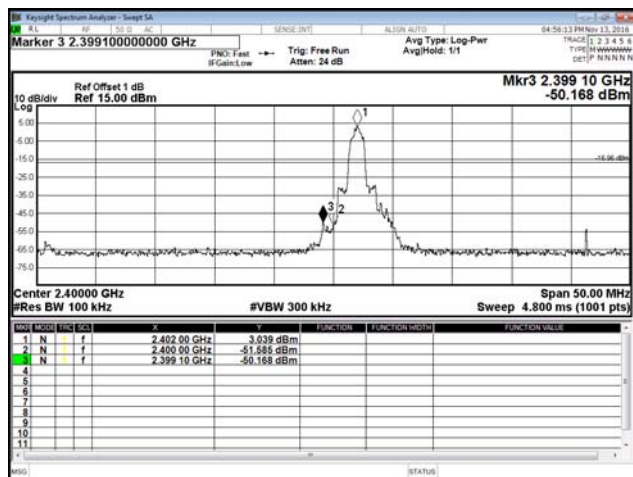



Modulation Standard:  $\pi/4$  DQPSK (2Mbps)  
Channel: 78

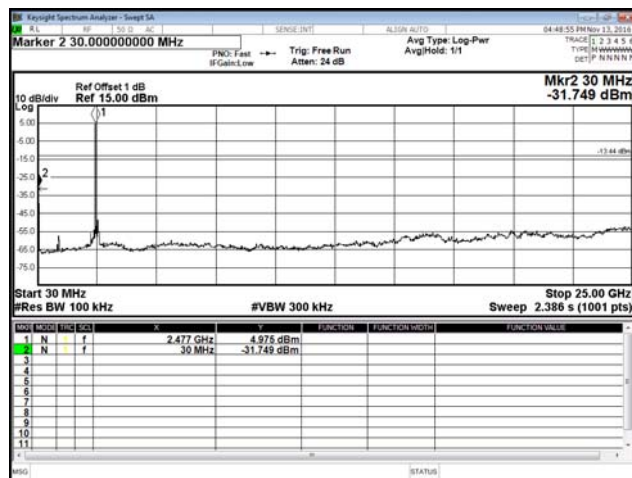
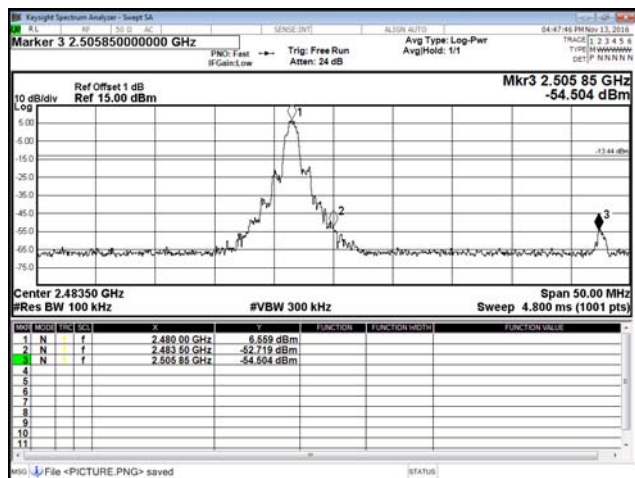

Modulation Standard: 8DPSK (3Mbps)  
Channel: 00

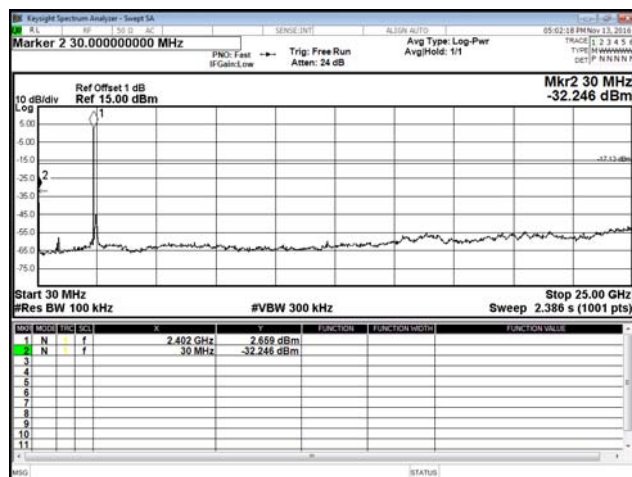
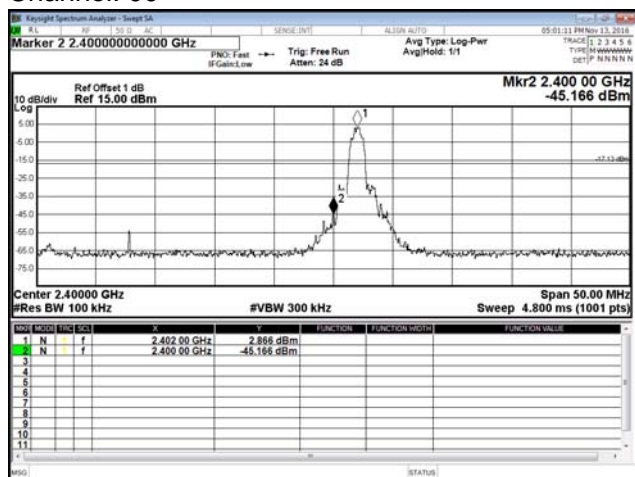

Modulation Standard: 8DPSK (3Mbps)  
Channel: 78

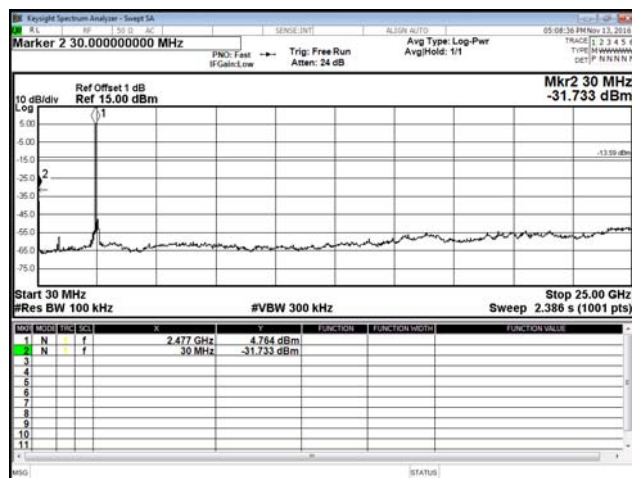
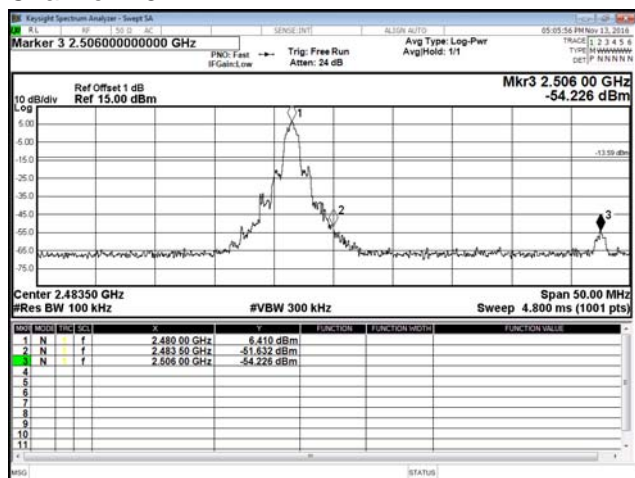



### Hopping test

Modulation Standard: GFSK (1Mbps)

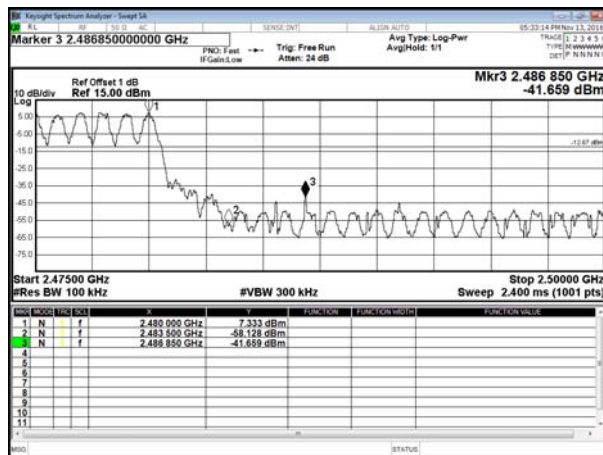
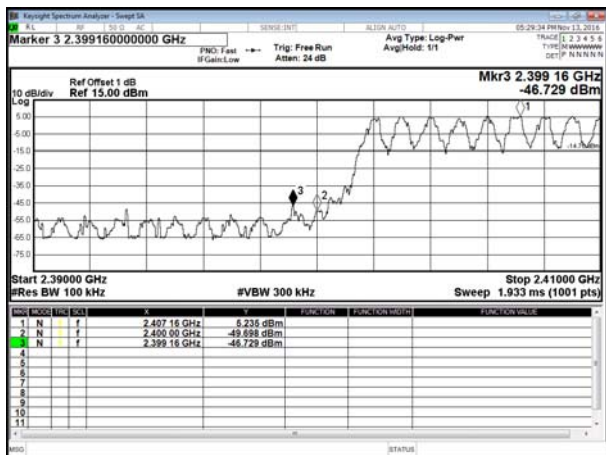

Modulation Standard:  $\pi/4$  DQPSK (2Mbps)

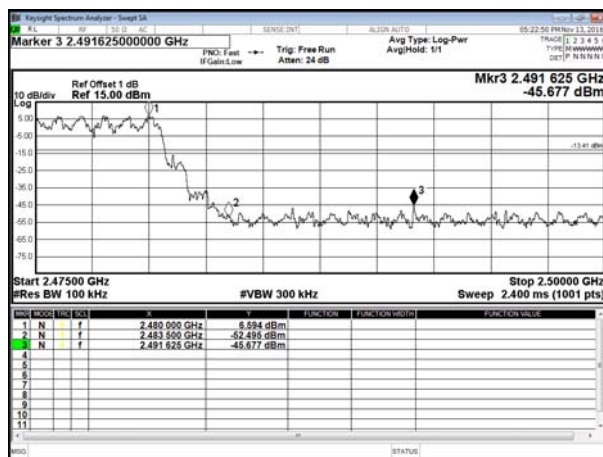
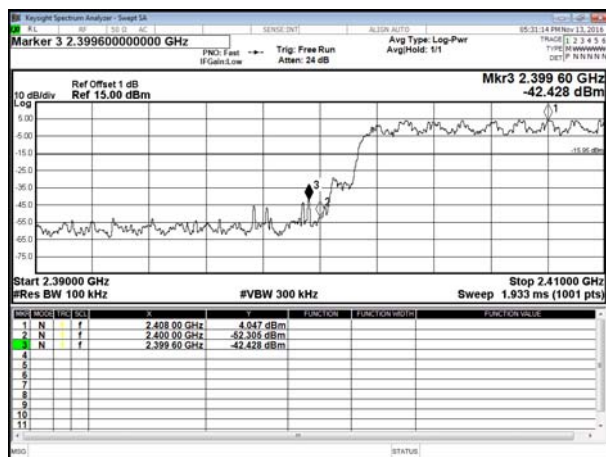

Modulation Standard: 8DPSK (3Mbps)

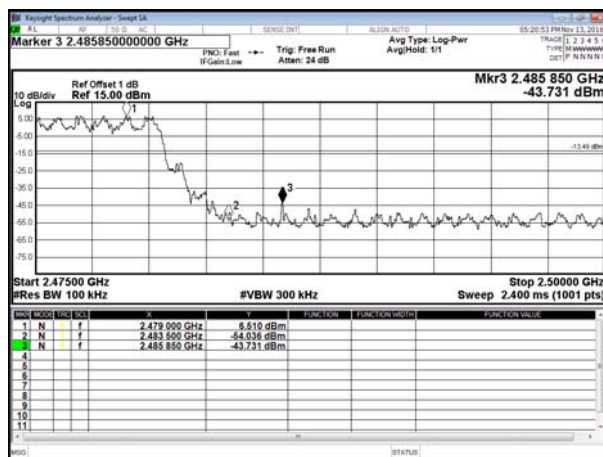
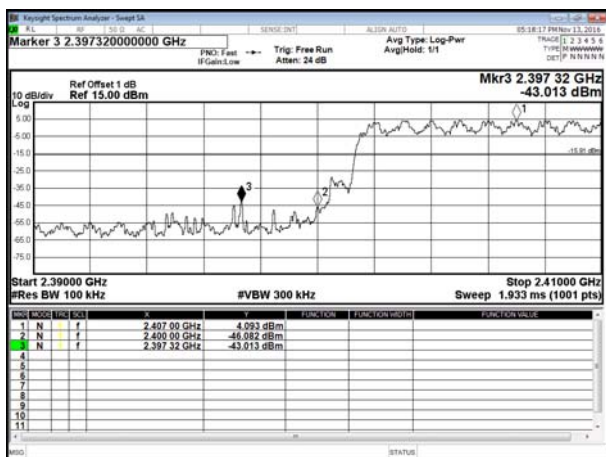



### 12.5 Restrict band emission Measurement Data

Power	: AC 120V	Pol/Phase	: VERTICAL
Test Mode	: GFSK, CH00	Temperature	: 23 ° C
Test date	: Nov. 13, 2016	Humidity	: 65 %

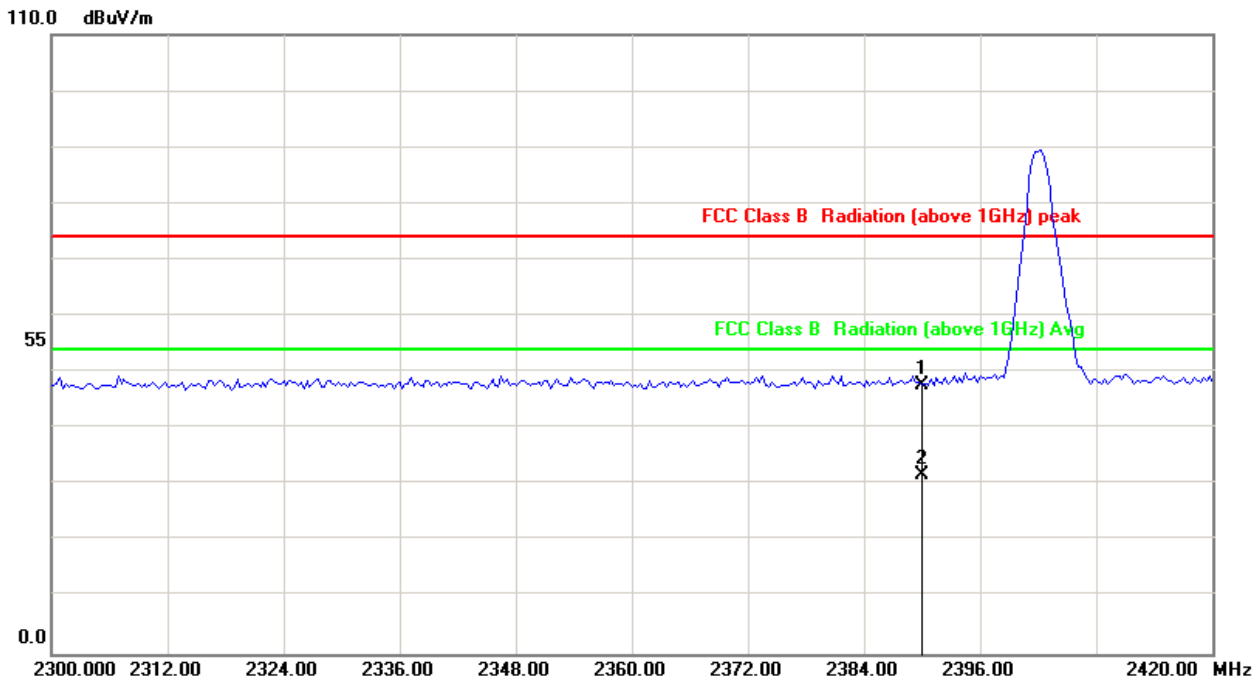

No.	Frequency (MHz)	Factor (dB/m)	Reading (dBuV)	Level (dBuV/m)	Limit (dBuV/m)	Margin (dB)	Detector
1	2390.000	-3.05	50.82	47.77	74.00	-26.23	peak
2	2390.000	-3.05	34.68	31.63	54.00	-22.37	AVG

**Note:** Level=Reading+Factor.

Margin=Level-Limit.



Power	: AC 120V	Pol/Phase	: HORIZONTAL
Test Mode	: GFSK, CH00	Temperature	: 23 ° C
Test date	: Nov. 13, 2016	Humidity	: 65 %

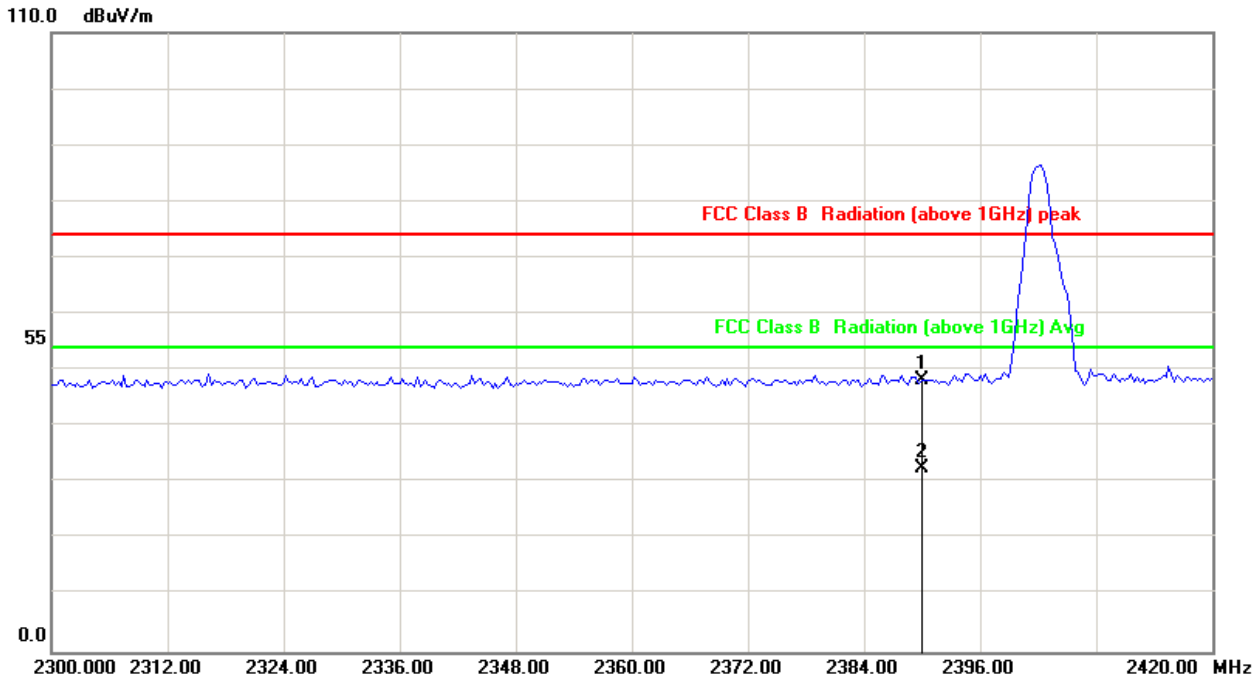

No.	Frequency (MHz)	Factor (dB/m)	Reading (dBuV)	Level (dBuV/m)	Limit (dBuV/m)	Margin (dB)	Detector
1	2390.000	-3.05	51.25	48.20	74.00	-25.80	peak
2	2390.000	-3.05	35.68	32.63	54.00	-21.37	AVG

Note: Level=Reading+Factor.

Margin=Level-Limit.



Power	: AC 120V	Pol/Phase	: VERTICAL
Test Mode	: GFSK, CH78	Temperature	: 23 ° C
Test date	: Nov. 13, 2016	Humidity	: 65 %

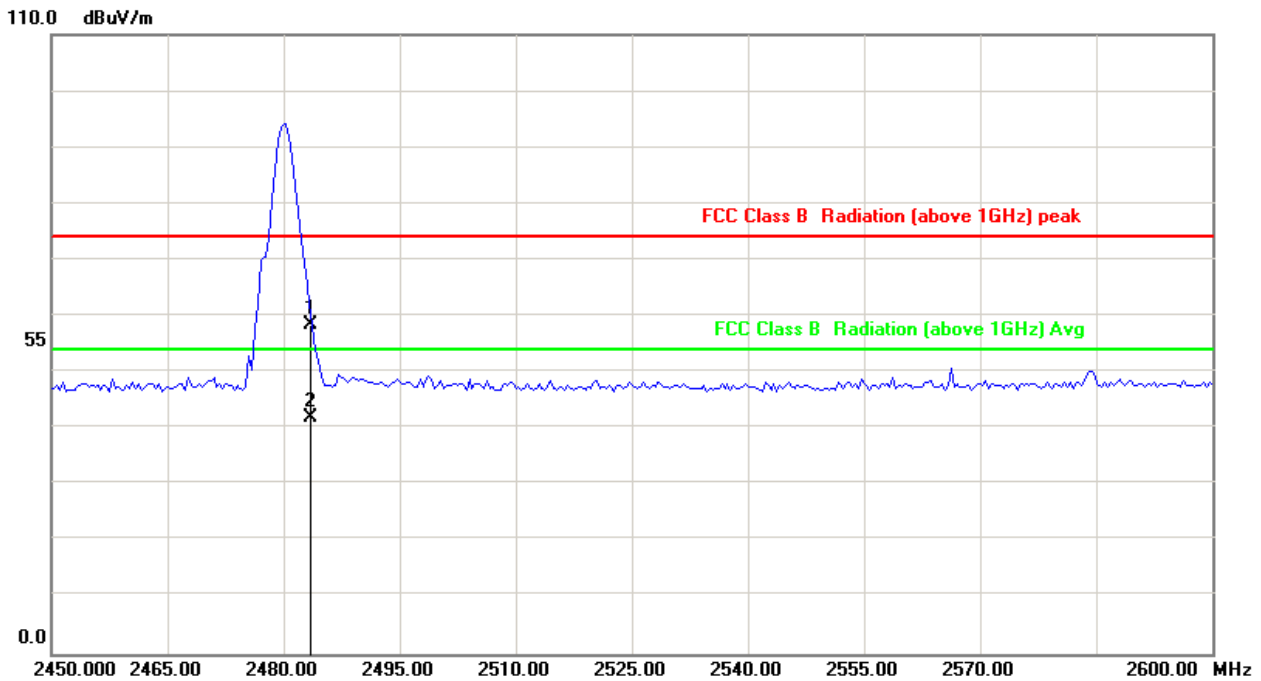

No.	Frequency (MHz)	Factor (dB/m)	Reading (dBuV)	Level (dBuV/m)	Limit (dBuV/m)	Margin (dB)	Detector
1	2483.500	-2.65	61.19	58.54	74.00	-15.46	peak
2	2483.500	-2.65	44.67	42.02	54.00	-11.98	AVG

**Note:** Level=Reading+Factor.

Margin=Level-Limit.





Power	: AC 120V	Pol/Phase	: HORIZONTAL
Test Mode	: GFSK, CH78	Temperature	: 23 ° C
Test date	: Nov. 13, 2016	Humidity	: 65 %

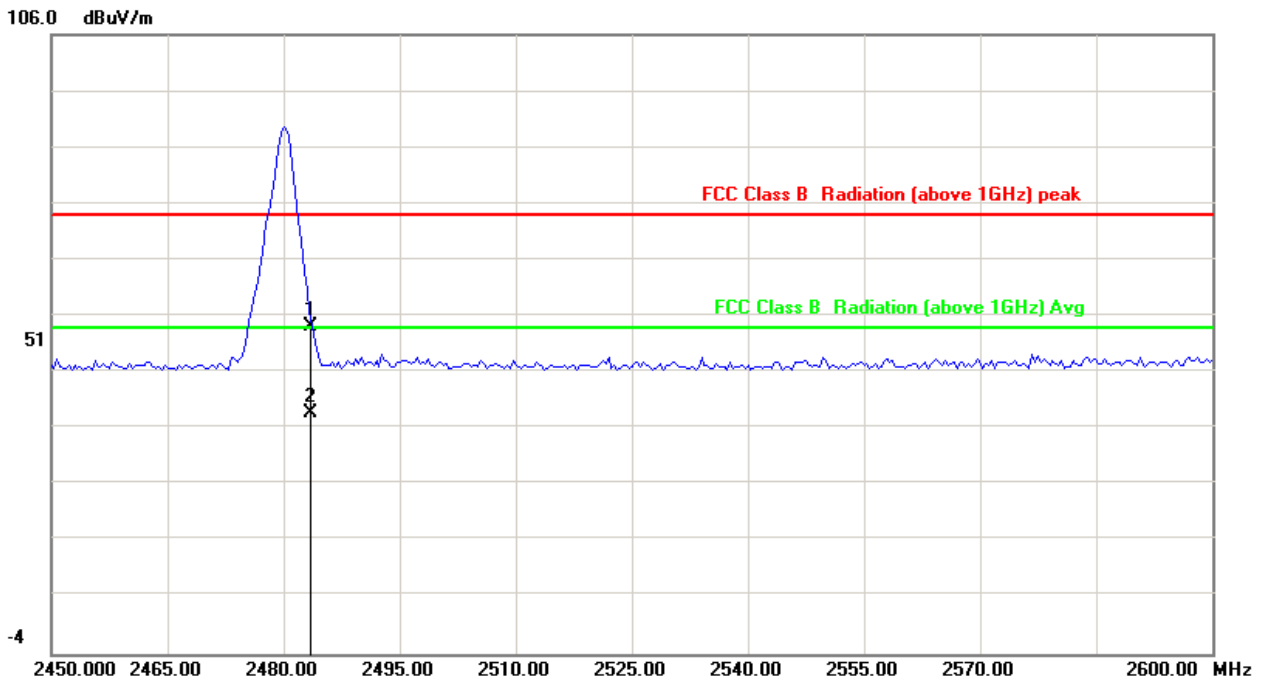

No.	Frequency (MHz)	Factor (dB/m)	Reading (dBuV)	Level (dBuV/m)	Limit (dBuV/m)	Margin (dB)	Detector
1	2483.500	-2.65	56.69	54.04	74.00	-19.96	peak
2	2483.500	-2.65	41.38	38.73	54.00	-15.27	AVG

**Note:** Level=Reading+Factor.  
Margin=Level-Limit.



Power	: AC 120V	Pol/Phase	: VERTICAL
Test Mode	: $\pi/4$ DQPSK, CH00	Temperature	: 23 ° C
Test date	: Nov. 13, 2016	Humidity	: 65 %

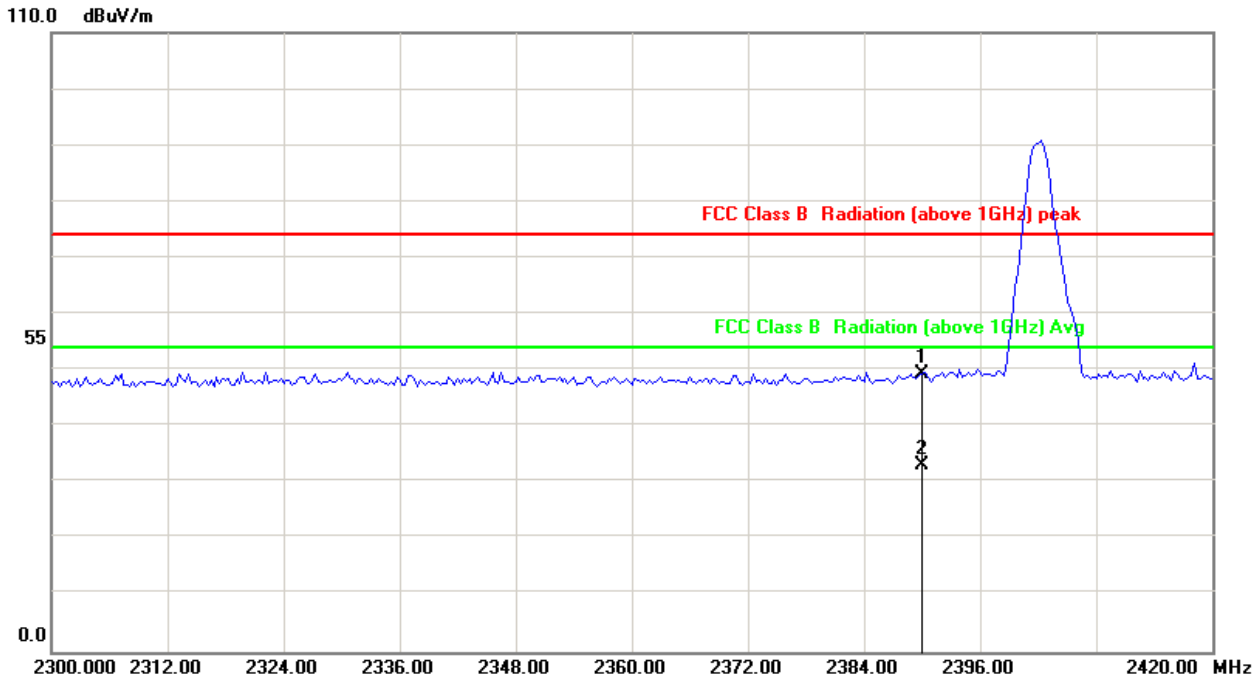

No.	Frequency (MHz)	Factor (dB/m)	Reading (dBuV)	Level (dBuV/m)	Limit (dBuV/m)	Margin (dB)	Detector
1	2390.000	-3.05	52.55	49.50	74.00	-24.50	peak
2	2390.000	-3.05	36.29	33.24	54.00	-20.76	AVG

**Note:** Level=Reading+Factor.

Margin=Level-Limit.



Power	: AC 120V	Pol/Phase	: HORIZONTAL
Test Mode	: $\pi/4$ DQPSK, CH00	Temperature	: 23 ° C
Test date	: Nov. 13, 2016	Humidity	: 65 %

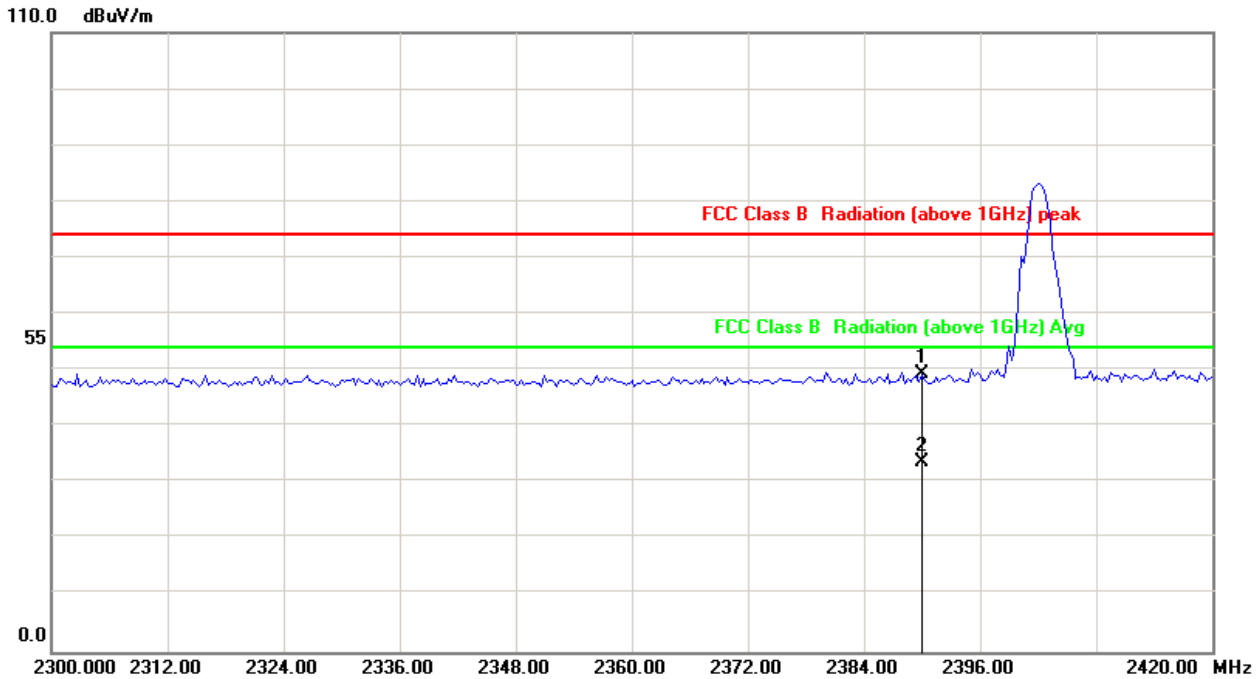

No.	Frequency (MHz)	Factor (dB/m)	Reading (dBuV)	Level (dBuV/m)	Limit (dBuV/m)	Margin (dB)	Detector
1	2390.000	-3.05	52.28	49.23	74.00	-24.77	peak
2	2390.000	-3.05	36.71	33.66	54.00	-20.34	AVG

**Note:** Level=Reading+Factor.

Margin=Level-Limit.



Power	: AC 120V	Pol/Phase	: VERTICAL
Test Mode	: $\pi/4$ DQPSK, CH78	Temperature	: 23 ° C
Test date	: Nov. 13, 2016	Humidity	: 65 %

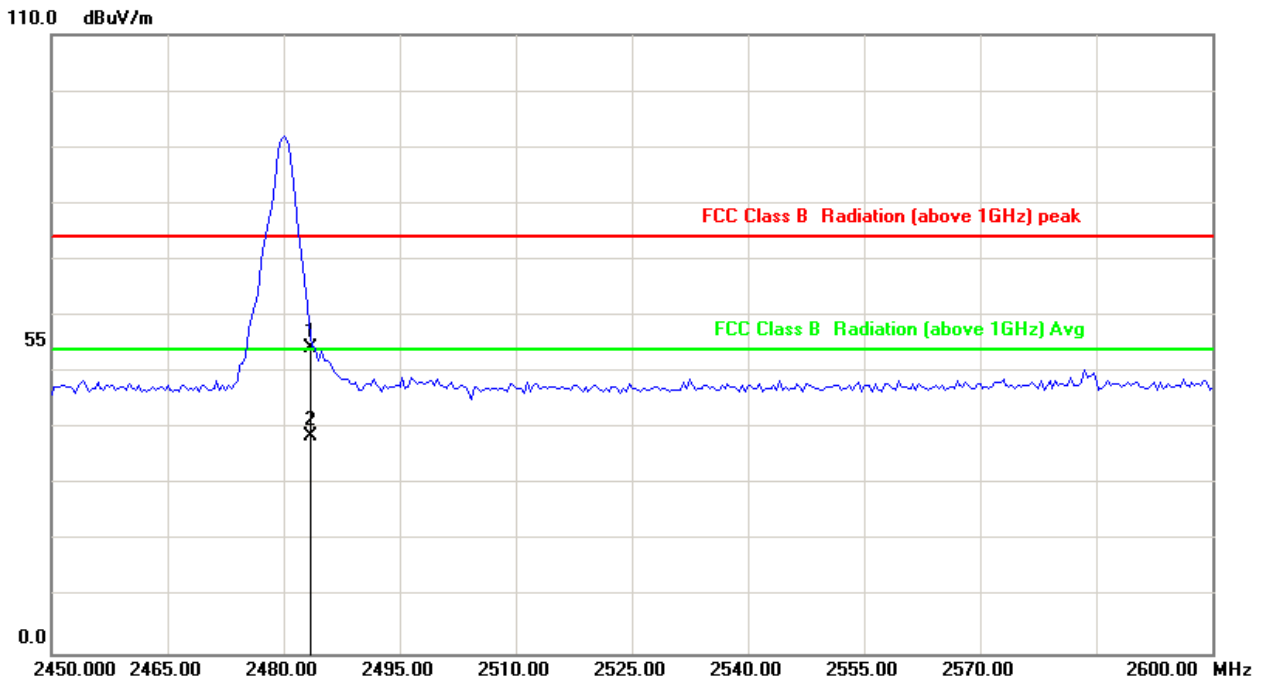

No.	Frequency (MHz)	Factor (dB/m)	Reading (dBuV)	Level (dBuV/m)	Limit (dBuV/m)	Margin (dB)	Detector
1	2483.500	-2.65	57.10	54.45	74.00	-19.55	peak
2	2483.500	-2.65	41.35	38.70	54.00	-15.30	AVG

**Note:** Level=Reading+Factor.

Margin=Level-Limit.



Power	: AC 120V	Pol/Phase	: HORIZONTAL
Test Mode	: $\pi / 4$ DQPSK, CH78	Temperature	: 23 ° C
Test date	: Nov. 13, 2016	Humidity	: 65 %

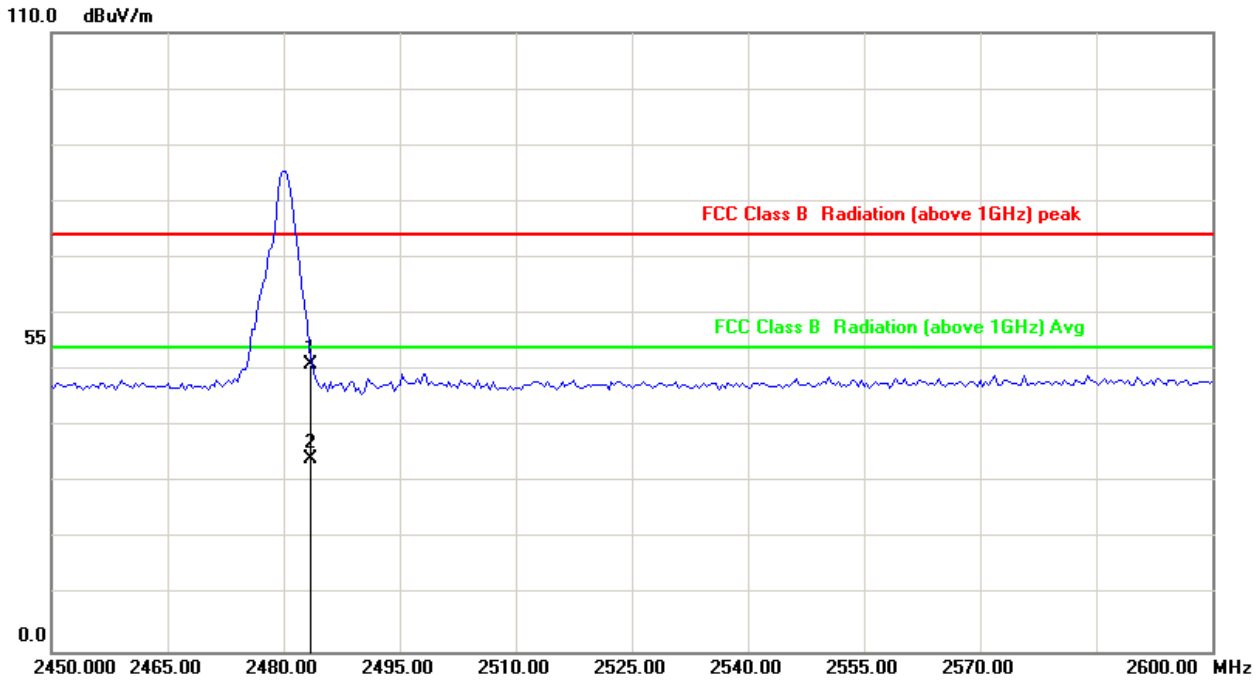

No.	Frequency (MHz)	Factor (dB/m)	Reading (dBuV)	Level (dBuV/m)	Limit (dBuV/m)	Margin (dB)	Detector
1	2483.500	-2.65	53.74	51.09	74.00	-22.91	peak
2	2483.500	-2.65	36.78	34.13	54.00	-19.87	AVG

**Note:** Level=Reading+Factor.

Margin=Level-Limit.



Power	: AC 120V	Pol/Phase	: VERTICAL
Test Mode	: 8DPSK, CH00	Temperature	: 23 ° C
Test date	: Nov. 13, 2016	Humidity	: 65 %

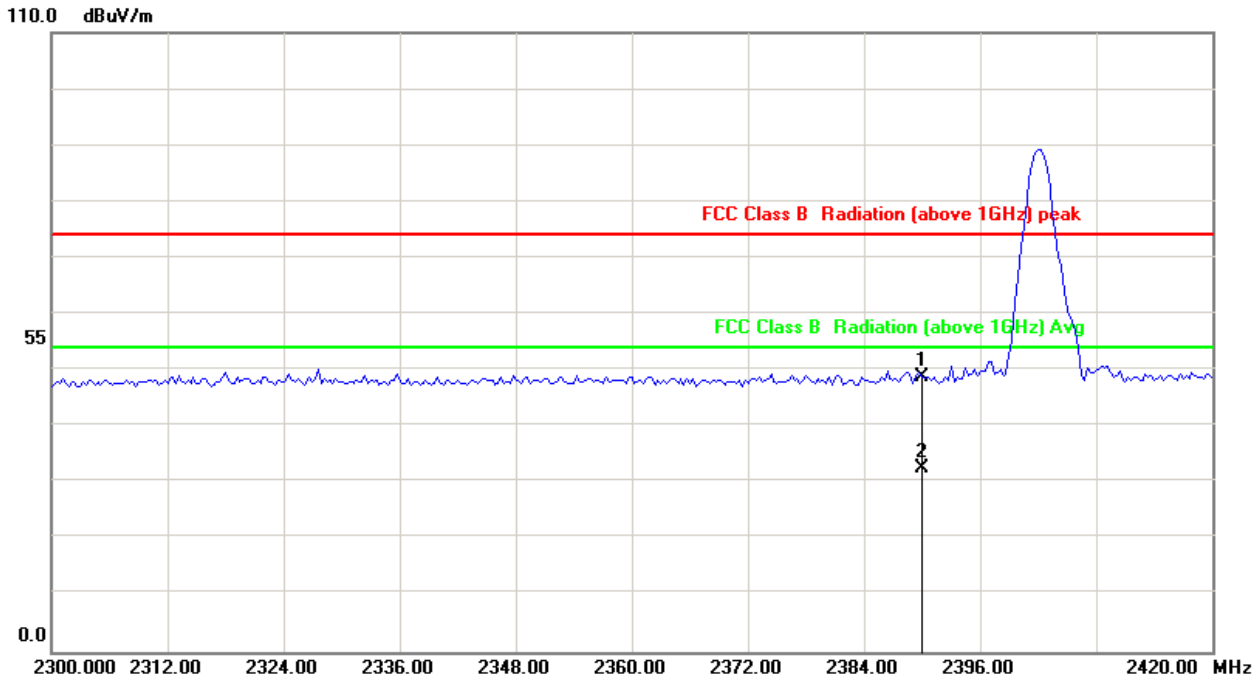

No.	Frequency (MHz)	Factor (dB/m)	Reading (dBuV)	Level (dBuV/m)	Limit (dBuV/m)	Margin (dB)	Detector
1	2390.000	-3.05	51.99	48.94	74.00	-25.06	peak
2	2390.000	-3.05	35.67	32.62	54.00	-21.38	AVG

**Note:** Level=Reading+Factor.

Margin=Level-Limit.



Power	: AC 120V	Pol/Phase	: HORIZONTAL
Test Mode	: 8DPSK, CH00	Temperature	: 23 ° C
Test date	: Nov. 13, 2016	Humidity	: 65 %

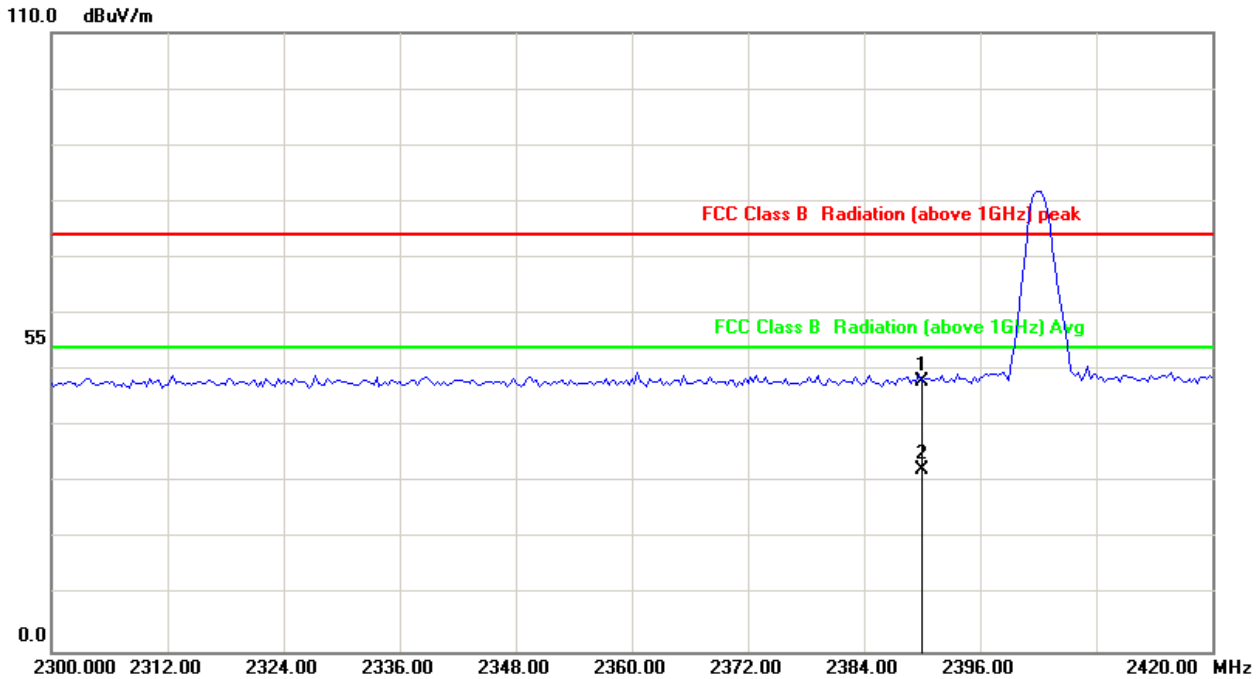

No.	Frequency (MHz)	Factor (dB/m)	Reading (dBuV)	Level (dBuV/m)	Limit (dBuV/m)	Margin (dB)	Detector
1	2390.000	-3.05	50.99	47.94	74.00	-26.06	peak
2	2390.000	-3.05	35.33	32.28	54.00	-21.72	AVG

**Note:** Level=Reading+Factor.

Margin=Level-Limit.



Power	: AC 120V	Pol/Phase	: VERTICAL
Test Mode	: 8DPSK, CH78	Temperature	: 23 ° C
Test date	: Nov. 13, 2016	Humidity	: 65 %

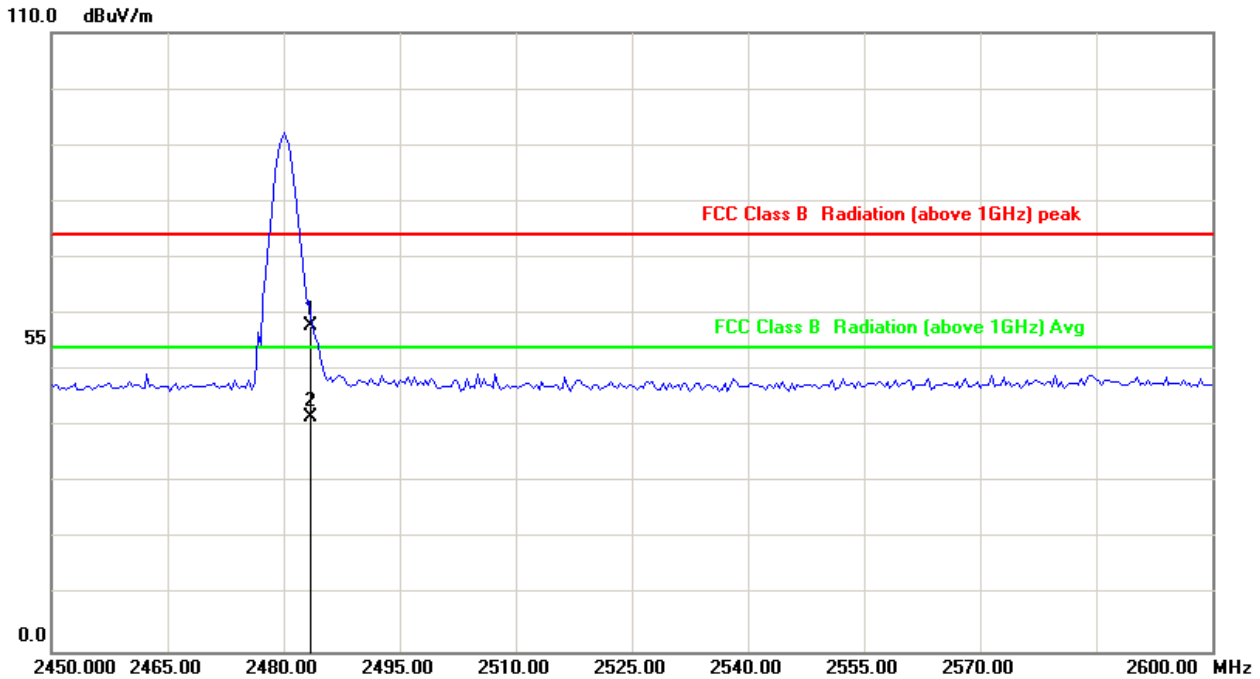

No.	Frequency (MHz)	Factor (dB/m)	Reading (dBuV)	Level (dBuV/m)	Limit (dBuV/m)	Margin (dB)	Detector
1	2483.500	-2.65	60.66	58.01	74.00	-15.99	peak
2	2483.500	-2.65	44.31	41.66	54.00	-12.34	AVG

**Note:** Level=Reading+Factor.

Margin=Level-Limit.





Power	: AC 120V	Pol/Phase	: HORIZONTAL
Test Mode	: 8DPSK, CH78	Temperature	: 23 ° C
Test date	: Nov. 13, 2016	Humidity	: 65 %

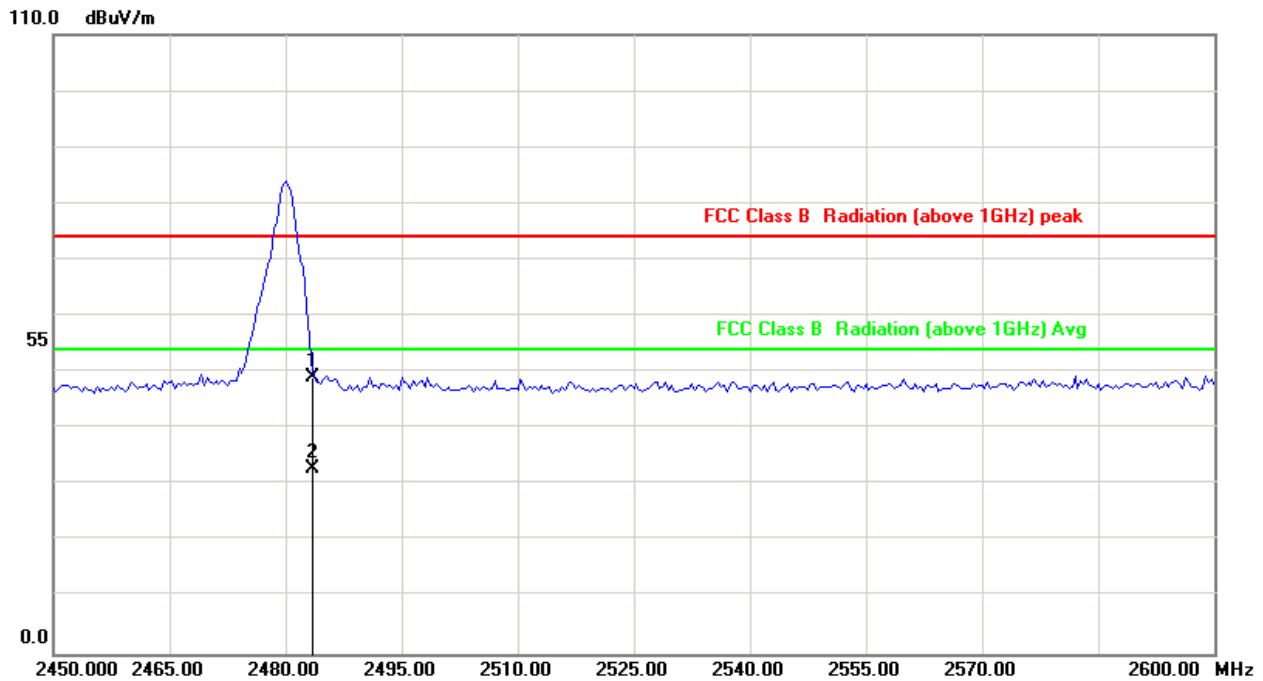

No.	Frequency (MHz)	Factor (dB/m)	Reading (dBuV)	Level (dBuV/m)	Limit (dBuV/m)	Margin (dB)	Detector
1	2483.500	-2.65	51.73	49.08	74.00	-24.92	peak
2	2483.500	-2.65	35.61	32.96	54.00	-21.04	AVG

**Note:** Level=Reading+Factor.

Margin=Level-Limit.



### 13. Restricted Bands of Operation

Only spurious emissions are permitted in any of the frequency bands listed below:

MHz	MHz	MHz	GHz
0.09000 – 0.11000	16.42000 – 16.42300	399.9 – 410.0	4.500 – 5.250
0.49500 – 0.505**	16.69475 – 16.69525	608.0 – 614.0	5.350 – 5.460
2.17350 – 2.19050	16.80425 – 16.80475	960.0 – 1240.0	7.250 – 7.750
4.12500 – 4.12800	25.50000 – 25.67000	1300.0 – 1427.0	8.025 – 8.500
4.17725 – 4.17775	37.50000 – 38.25000	1435.0 – 1626.5	9.000 – 9.200
4.20725 – 4.20775	73.00000 – 74.60000	1645.5 – 1646.5	9.300 – 9.500
6.21500 – 6.21800	74.80000 – 75.20000	1660.0 – 1710.0	10.600 – 12.700
6.26775 – 6.26825	108.00000 – 121.94000	1718.8 – 1722.2	13.250 – 13.400
6.31175 – 6.31225	123.00000 – 138.00000	2200.0 – 2300.0	14.470 – 14.500
8.29100 – 8.29400	149.90000 – 150.05000	2310.0 – 2390.0	15.350 – 16.200
8.36200 – 8.36600	156.52475 – 156.52525	2483.5 – 2500.0	17.700 – 21.400
8.37625 – 8.38675	156.70000 – 156.90000	2655.0 – 2900.0	22.010 – 23.120
8.41425 – 8.41475	162.01250 – 167.17000	3260.0 – 3267.0	23.600 – 24.000
12.29000 – 12.29300	167.72000 – 173.20000	3332.0 – 3339.0	31.200 – 31.800
12.51975 – 12.52025	240.00000 – 285.00000	3345.8 – 3358.0	36.430 – 36.500
12.57675 – 12.57725	322.00000 – 335.40000	3600.0 – 4400.0	Above 38.6
13.36000 – 13.41000			

\*\* : Until February 1, 1999, this restricted band shall be 0.490-0.510 MHz

#### 13.1 Labeling Requirement

The device shall bear the following statement in a conspicuous location on the device:

This device complies with part 15 of the FCC Rules. Operation is subject to the following two conditions: (1) This device may not cause harmful interference, and (2) this device must accept any interference received, including interference that may cause undesired operation.