

S

T

S

L

A

B



FCC TEST REPORT

Report No: STS1711115W01

Issued for

YULIN TECH CO., LTD.

No.504, 5 Floor, Kaizhongzhahui park, Huan Road No.8,
Zhongkai Hi-tech Industry Park, Huizhou, Guangdong
Province, 516006, P.R. China

Product Name:	Wireless Charger TX Pad
Brand Name:	N/A
Model Name:	WTS-H001A - 001
Series Model:	WTS-H001A-002, WTS-H001A-003, WTS-H001A-004, WTS-H001A-005, WTS-H001A-006, WTS-H001A-007, WTS-H001A-008, WTS-H001A-009, WTS-H001A-0010
FCC ID:	2AKDFWTS-H001A-001
Test Standard:	FCC Part 15 Subpart C

Any reproduction of this document must be done in full. No single part of this document may be reproduced without permission from STS, All Test Data Presented in this report is only applicable to presented Test sample.





TEST RESULT CERTIFICATION

Applicant's name : YULIN TECH CO., LTD.
Address : No.504, 5 Floor, Kaizhongzhahui park, Huaan Road No.8, Zhongkai Hi-tech Industry Park, Huizhou, Guangdong Province, 516006, P.R. China
Manufacture's Name : YULIN TECH CO., LTD.
Address : No.504, 5 Floor, Kaizhongzhahui park, Huaan Road No.8, Zhongkai Hi-tech Industry Park, Huizhou, Guangdong Province, 516006, P.R. China

Product description

Product Name: Wireless Charger TX Pad
Brand Name: N/A
Model Name.....: WTS-H001A - 001
Series Model: WTS-H001A-002, WTS-H001A-003, WTS-H001A-004, WTS-H001A-005, WTS-H001A-006, WTS-H001A-007, WTS-H001A-008, WTS-H001A-009, WTS-H001A-0010
Test Standards.....: FCC Part 15 Subpart C
Test Procedure : ANSI C63.10-2013

This device described above has been tested by STS, the test results show that the equipment under test (EUT) is in compliance with the FCC requirements. And it is applicable only to the tested sample identified in the report.

This report shall not be reproduced except in full, without the written approval of STS, this document may be altered or revised by STS, personal only, and shall be noted in the revision of the document.

Date of performance of tests: 15 Nov. 2017~16 Nov. 2017
Date of Issue : 17 Nov. 2017
Test Result : Pass

Testing Engineer : Sean She
(Sean she)

Technical Manager : Hakim.hou
(Hakim.hou)

Authorized Signatory : Vita Li
(Vita Li)





Table of Contents	Page
1. SUMMARY OF TEST RESULTS	5
1.1 TEST FACTORY	5
1.2 MEASUREMENT UNCERTAINTY	5
2. GENERAL INFORMATION	6
2.1 GENERAL DESCRIPTION OF EUT	6
2.2 DESCRIPTION OF TEST MODES	7
2.3 BLOCK DIGRAM SHOWING THE CONFIGURATION OF SYSTEM TESTED	8
2.4 DESCRIPTION OF SUPPORT UNITS	9
2.5 EQUIPMENTS LIST FOR ALL TEST ITEMS	10
3.CONDUCTED EMISSION TEST RESULT(SECTION 15.207)	11
3.1 POWER LINE CONDUCTED EMISSION LIMITS	11
3.2 TEST PROCEDURE	12
3.3 TEST SETUP	12
3.4 EUT OPERATING CONDITIONS	12
3.5TEST RESULTS	13
4. RADIATED& FIELD EMISSION TEST RESULT(SECTIOU 15.209)	15
4.1 LIMIT	15
4.2 TEST PROCEDURE	15
4.3 TEST SETUP	16
4.4 TEST RESULTS	17
APPENDIX-PHOTOS OF TEST SETUP	20



Revision History

Rev.	Issue Date	Report NO.	Effect Page	Contents
00	17 Nov. 2017	STS1711115W01	ALL	Initial Issue



1. SUMMARY OF TEST RESULTS

Test procedures according to the technical standards:

FCC Part15 , Subpart C			
Standard Section	Test Item	Judgment	Remark
15.207	Conducted Emission	PASS	
15.209 (a)	Radiated emission, Spurious Emission	PASS	

1.1 TEST FACTORY

Shenzhen STS Test Services Co., Ltd.
 Add. : 1/F., Building B, Zhuoke Science Park, No.190, Chongqing Road,
 Fuyong Street, Bao'an District, Shenzhen, Guangdong, China
 CNAS Registration No.: L7649; FCC Registration No.: 625569
 IC Registration No.: 12108A; A2LA Certificate No.: 4338.01;

1.2 MEASUREMENT UNCERTAINTY

The reported uncertainty of measurement $y \pm U$ · where expended uncertainty **U** is based on a standard uncertainty multiplied by a coverage factor of **k=2** · providing a level of confidence of approximately **95 %** .

No.	Item	Uncertainty
1	Conducted Emission (9KHz-150KHz)	±2.88dB
2	Conducted Emission (150KHz-30MHz)	±2.67 dB
3	All emissions,radiated(<1G) 30MHz-200MHz	±2.83dB
4	All emissions,radiated(<1G) 200MHz-1000MHz	±2.94dB
5	Temperature	±0.5°C
6	Humidity	±2%

2. GENERAL INFORMATION

2.1 GENERAL DESCRIPTION OF EUT

Product Name	Wireless Charger TX Pad
Trade Name	N/A
Model Name	WTS-H001A - 001
Series Model	WTS-H001A-002, WTS-H001A-003, WTS-H001A-004, WTS-H001A-005, WTS-H001A-006, WTS-H001A-007, WTS-H001A-008, WTS-H001A-009, WTS-H001A-0010
Model Difference	Only different in model name and color
Channel List	Please refer to the Note 2.
Equipemnt Category	Non-ISM frequency
Operating frequency	110 KHz ~205KHz
Test frequency	127 KHz ~175KHz
Modulation Type	GFSK
Power rating	DC 9V
Hardware version number	Y123010000010
Software version number	WTS-H001A-V1.10
Connecting I/O Port(s)	Please refer to the User's Manual

Note:

1. For a more detailed features description, please refer to the manufacturer's specifications or the User's Manual.
- 2.

Channel List					
Channel	Frequency (KHz)	Channel	Frequency (KHz)	Channel	Frequency (KHz)
00	150				

3. Table for Filed Antenna

Ant	Brand	Model Name	Antenna Type	Connector	NOTE
1	N/A	WTS-H001A - 001	Coil	N/A	Antenna

The EUT antenna is Coil Antenna. No antenna other than that furnished by the responsible party shall be used with the device.

2.2 DESCRIPTION OF TEST MODES

To investigate the maximum EMI emission characteristics generates from EUT, the test system was pre-scanning tested base on the consideration of following EUT operation mode or test configuration mode which possible have effect on EMI emission level. Each of these EUT operation mode(s) or test configuration mode(s) mentioned above was evaluated respectively.

Pretest Mode	Description
Mode 1	Charging+TX Mode

For Conducted Emission	
Final Test Mode	Description
Mode 1	Charging+TX Mode

For Radiated Emission	
Final Test Mode	Description
Mode 1	Charging+TX Mode

2.3 BLOCK DIGRAM SHOWING THE CONFIGURATION OF SYSTEM TESTED

During testing channel & power controlling software provided by the customer was used to control the operating channel as well as the output power level. The RF output power selection is for the setting of RF output power expected by the customer and is going to be fixed on the firmware of the final end product power parameters

Conducted Emission Test

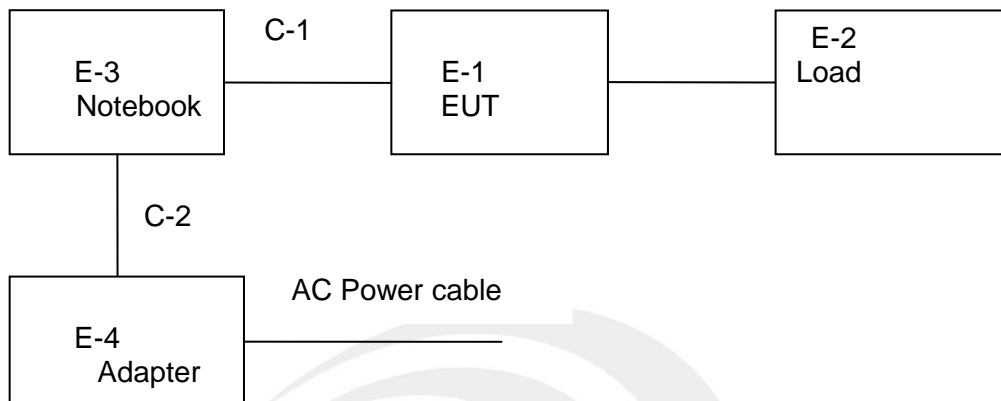

Radiated Emission Test

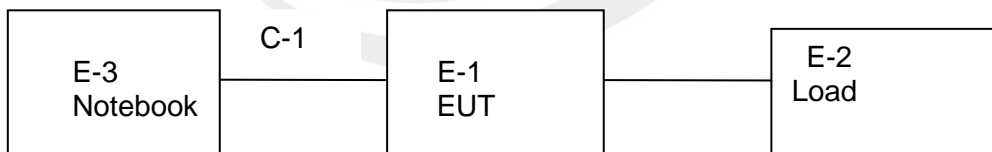



2.4 DESCRIPTION OF SUPPORT UNITS

The EUT has been tested as an independent unit together with other necessary accessories or support units. The following support units or accessories were used to form a representative test configuration during the tests.

Item	Equipment	Mfr/Brand	Model/Type No.	Serial No.	Note
E-2	Load	N/A	N/A	N/A	N/A
E-3	Notebook	HP	N/A	N/A	N/A
E-4	Adapter	HP	N/A	N/A	N/A

Item	Shielded Type	Ferrite Core	Length	Note
C-1	USB Cable (FTP)	NO	80cm	/
C-2	DC Power cable	NO	120cm	/

Note:

- (1) FCC DOC approved.
- (2) FTP is Foiled Twisted Pair.



2.5 EQUIPMENTS LIST FOR ALL TEST ITEMS

Radiation Test equipment

Kind of Equipment	Manufacturer	Type No.	Serial No.	Last calibration	Calibrated until
Test Receiver	R&S	ESCI	101427	2017.10.15	2018.10.14
Bilog Antenna	TESEQ	CBL6111D	34678	2017.03.24	2018.03.23
50Ω Coaxial Switch	Anritsu	MP59B	6200264416	2017.10.15	2018.10.14
PreAmplifier	Agilent	8449B	60538	2017.10.15	2018.10.14
Loop Antenna	EMCO	6502	9003-2485	2017.10.15	2018.10.14
USB RF power sensor	DARE	RPR3006W	15I00041SNO03	2017.10.15	2018.10.14

Conduction Test equipment

Kind of Equipment	Manufacturer	Type No.	Serial No.	Last calibration	Calibrated until
Test Receiver	R&S	ESCI	101427	2017.10.15	2018.10.14
LISN	R&S	ENV216	101242	2017.10.15	2018.10.14
LISN	EMCO	3810/2NM	000-23625	2017.10.15	2018.10.14

3.CONDUCTED EMISSION TEST RESULT(SECTION 15.207)

3.1 POWER LINE CONDUCTED EMISSION LIMITS

Operating frequency band. In case the emission fall within the restricted band specified on Part 15.207 limit in the table below has to be followed.

FREQUENCY (MHz)	Class B (dBuV)	
	Quasi-peak	Average
0.15 -0.5	66 - 56 *	56 - 46 *
0.50 -5.0	56.00	46.00
5.0 -30.0	60.00	50.00

Note:

- (1) The tighter limit applies at the band edges.
- (2) The limit of " * " marked band means the limitation decreases linearly with the logarithm of the frequency in the range.

The following table is the setting of the receiver

Receiver Parameters	Setting
Attenuation	10 dB
Start Frequency	0.15 MHz
Stop Frequency	30 MHz
IF Bandwidth	9 kHz

3.2 TEST PROCEDURE

- a. The EUT was placed 0.8 meters from the horizontal ground plane with EUT being connected to the power mains through a line impedance stabilization network (LISN). All other support equipments powered from additional LISN(s). The LISN provide 50 Ohm/ 50uH of coupling impedance for the measuring instrument.
- b. Interconnecting cables that hang closer than 40 cm to the ground plane shall be folded back and forth in the center forming a bundle 30 to 40 cm long.
- c. I/O cables that are not connected to a peripheral shall be bundled in the center. The end of the cable may be terminated, if required, using the correct terminating impedance. The overall length shall not exceed 1 m.
- d. LISN at least 80 cm from nearest part of EUT chassis.
- e. For the actual test configuration, please refer to the related Item –EUT Test Photos.

3.3 TEST SETUP

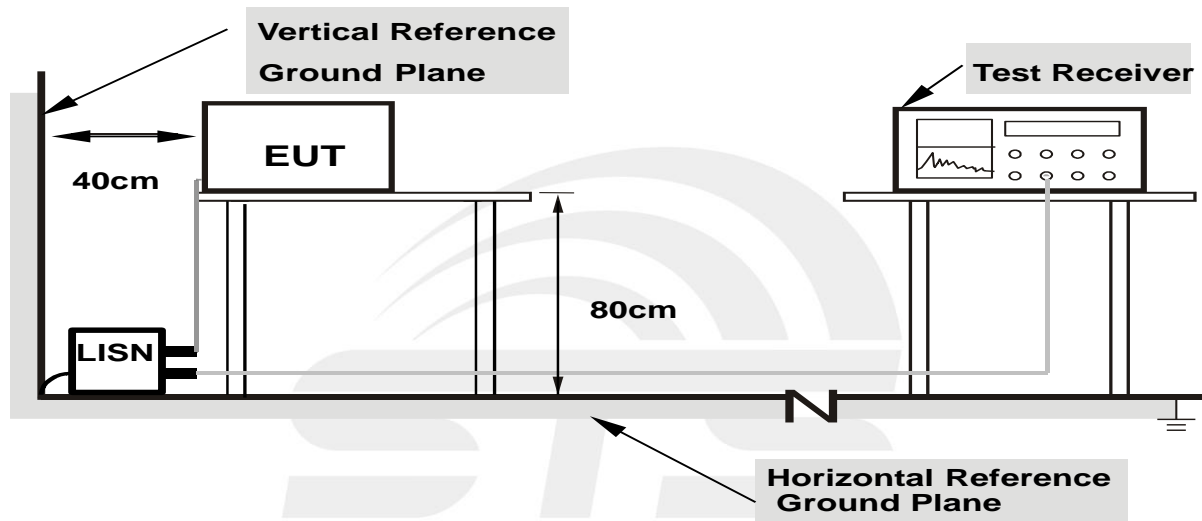

- Note: 1. Support units were connected to second LISN.**
2. Both of LISNs (AMN) are 80 cm from EUT and at least 80 cm from other units and other metal planes

3.4 EUT OPERATING CONDITIONS

The EUT was configured for testing in a typical fashion (as a customer would normally use it). The EUT has been programmed to continuously transmit during test. This operating condition was tested and used to collect the included data.



3.5TEST RESULTS

Temperature:	26 °C	Relative Humidity:	54%
Pressure:	1010hPa	Phase:	L
Test Voltage:	AC 120V/60Hz	Test Mode:	Mode 1

No.	Frequency (MHz)	Reading (dBuV)	Factor (dB)	Result (dBuV)	Limit (dBuV/m)	Margin (dB)	Detector
1	0.1740	45.81	9.79	55.60	64.77	-9.17	QP
2	0.1740	29.57	9.79	39.36	54.77	-15.41	AVG
3	0.2420	37.18	9.97	47.15	62.03	-14.88	QP
4	0.2420	16.93	9.97	26.90	52.03	-25.13	AVG
5	0.4660	27.71	10.03	37.74	56.58	-18.84	QP
6	0.4660	10.99	10.03	21.02	46.58	-25.56	AVG
7	0.5380	26.96	9.99	36.95	56.00	-19.05	QP
8	0.5380	10.97	9.99	20.96	46.00	-25.04	AVG
9	2.9260	29.82	9.81	39.63	56.00	-16.37	QP
10	2.9260	10.52	9.81	20.33	46.00	-25.67	AVG
11	9.2700	35.38	10.13	45.51	60.00	-14.49	QP
12	9.2700	23.94	10.13	34.07	50.00	-15.93	AVG

Remark:

1. All readings are Quasi-Peak and Average values.
2. Margin = Result (Result =Reading + Factor)–Limit

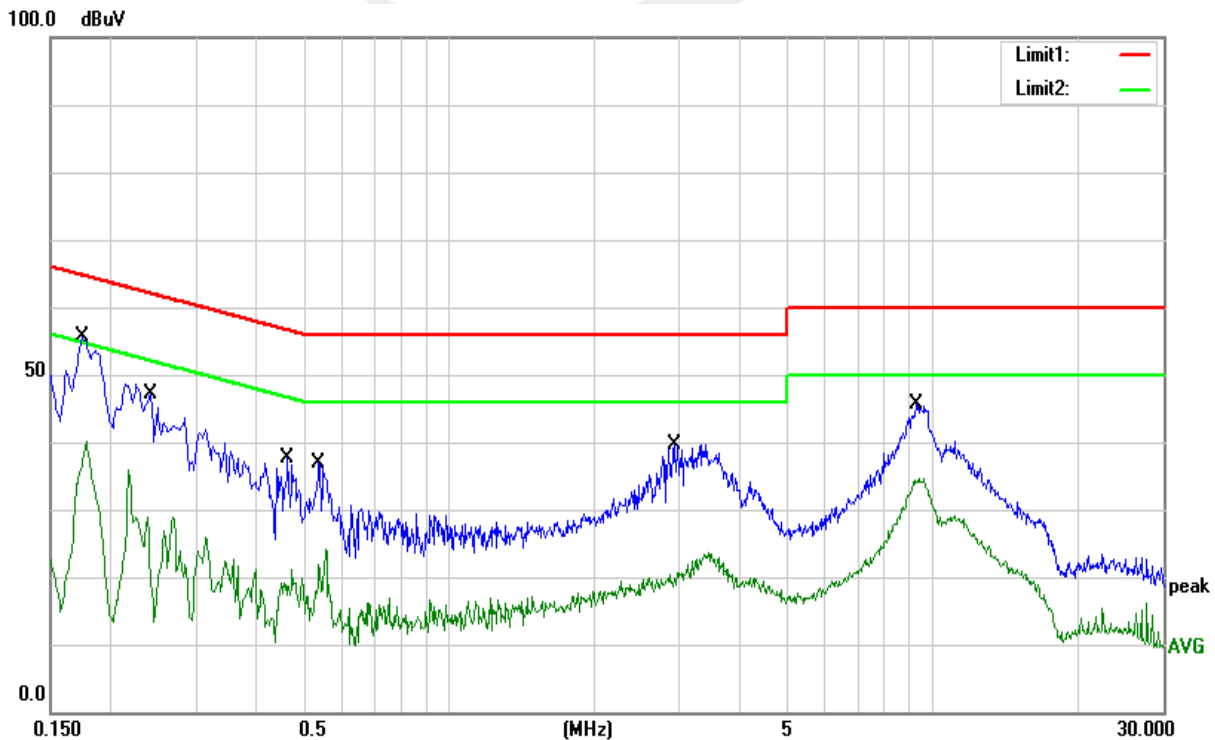



Temperature:	26 °C	Relative Humidity:	54%
Pressure:	1010hPa	Phase:	N
Test Voltage:	AC 120V/60Hz	Test Mode:	Mode 1

No.	Frequency (MHz)	Reading (dBuV)	Factor (dB)	Result (dBuV)	Limit (dBuV/m)	Margin (dB)	Detector
1	0.1500	51.40	9.75	61.15	66.00	-4.85	QP
2	0.1500	36.04	9.75	45.79	56.00	-10.21	AVG
3	0.1820	44.95	9.83	54.78	64.39	-9.61	QP
4	0.1820	31.87	9.83	41.70	54.39	-12.69	AVG
5	0.4540	26.24	10.02	36.26	56.80	-20.54	QP
6	0.4540	11.43	10.02	21.45	46.80	-25.35	AVG
7	2.2260	28.53	9.89	38.42	56.00	-17.58	QP
8	2.2260	11.38	9.89	21.27	46.00	-24.73	AVG
9	9.4060	35.52	9.92	45.44	60.00	-14.56	QP
10	9.4060	23.92	9.92	33.84	50.00	-16.16	AVG
11	16.6100	28.31	10.21	38.52	60.00	-21.48	QP
12	16.6100	16.67	10.21	26.88	50.00	-23.12	AVG

Remark:

1. All readings are Quasi-Peak and Average values.
2. Margin = Result (Result = Reading + Factor) - Limit

100.0 dBuV

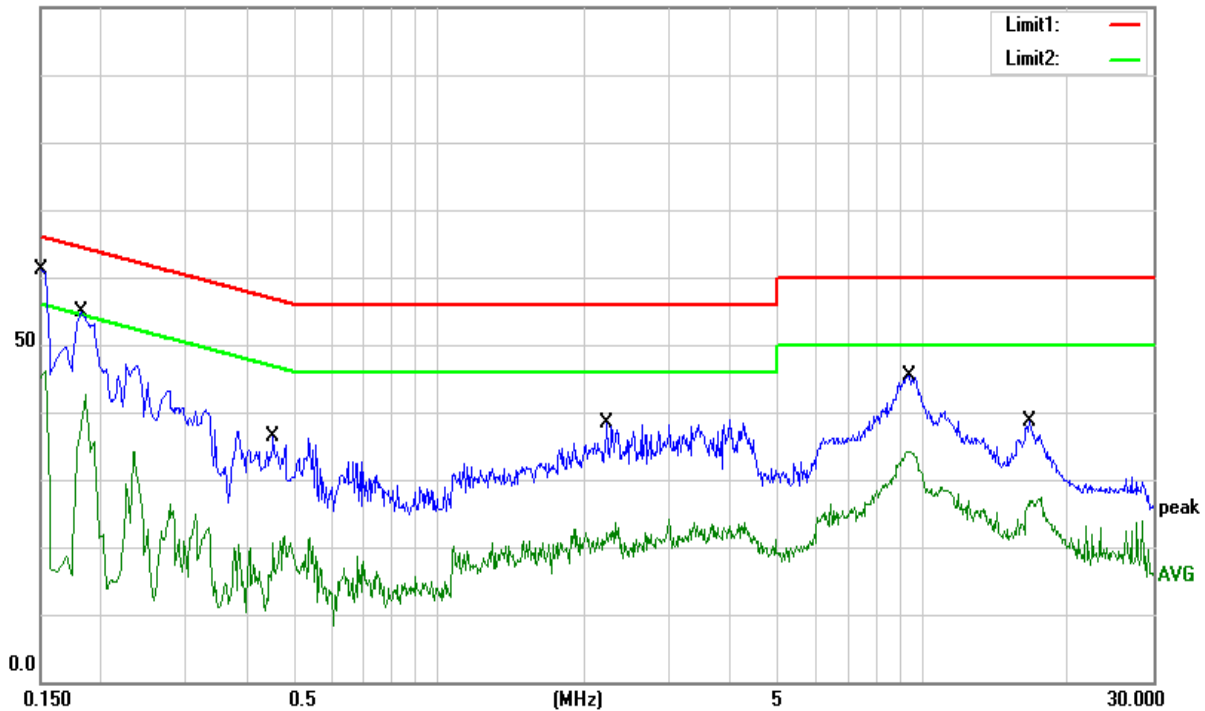

4. RADIATED& FIELD EMISSION TEST RESULT(SECTIOU 15.209)

4.1 Limit

Frequency [MHz]	Field Strength [uV/m]	Measurement Distance [Meters]
0.009 ~ 0.490	2400/F (kHz)	300
0.490 ~ 1.705	24000/F (kHz)	30
1.705 ~ 30	30	30
30 ~ 88	100	3
88 ~ 216	150	3
216 ~ 960	200	3
Above 960	500	3

Note:

- (1) The limit for radiated test was performed according to FCC PART 15C.
- (2) The tighter limit applies at the band edges.
- (3) Emission level (dBuV/m)=20log Emission level (uV/m).

Receiver Parameter	Setting
Attenuation	Auto
Start ~ Stop Frequency	9kHz~90kHz / RB 200Hz for AV
Start ~ Stop Frequency	90kHz~110kHz / RB 200Hz for QP
Start ~ Stop Frequency	110kHz~490kHz / RB 200Hz for AV
Start ~ Stop Frequency	490kHz~30MHz / RB 9kHz for QP
Start ~ Stop Frequency	30MHz~1000MHz / RB 120kHz for QP

§ 15.209(d)The emission limits shown in the above table are based on measurements employing a CISPR quasi-peak detector except for the frequency bands 9-90 kHz, 110-490 kHz and above 1000 MHz. Radiated emission limits in these three bands are based on measurements employing an average detector.

4.2 TEST PROCEDURE

- a. The measuring distance of at 3 m shall be used for measurements at frequency 0.009MHz up to 1GHz.
- b. The EUT was placed on the top of a rotating table 0.8 meter above the ground at a 3 meter anechoic chamber. The table was rotated 360 degrees to determine the position of the highest radiation.
- c. The initial step in collecting conducted emission data is a spectrum analyzer peak detector mode pre-scanning the measurement frequency range. Significant peaks are then marked and then Quasi Peak detector mode re-measured.
- d. If the Peak Mode measured value compliance with and lower than Quasi Peak Mode Limit, the EUT shall be deemed to meet QP Limits and then no additional QP Mode measurement performed.
- e. For the actual test configuration, please refer to the related Item –EUT Test Photos.

Note:

Both horizontal and vertical antenna polarities were tested and performed pretest to three orthogonal axis. The worst case emissions were reported.

4.3 TEST SETUP

(A) Radiated Emission Test-Up Frequency Below 30MHz

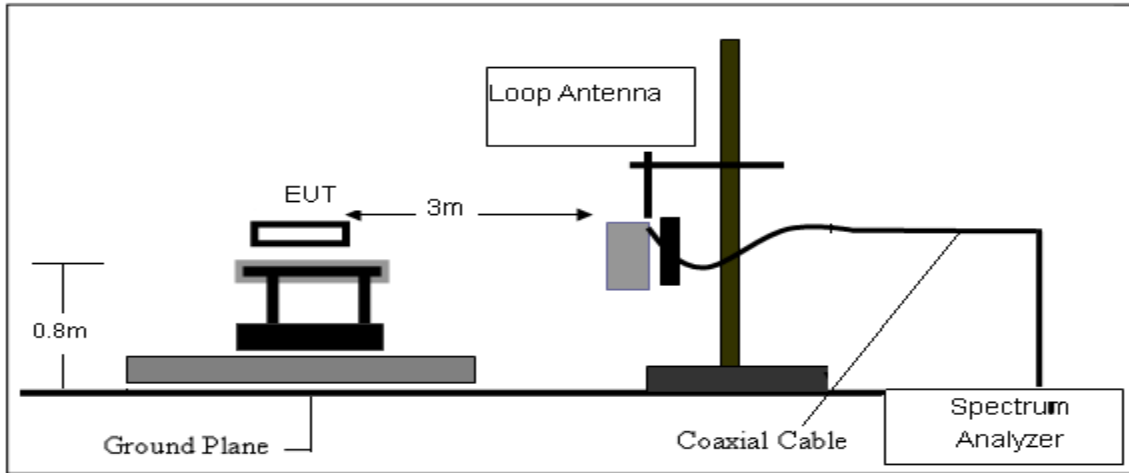

(B) Radiated Emission Test-Up Frequency 30MHz~1GHz

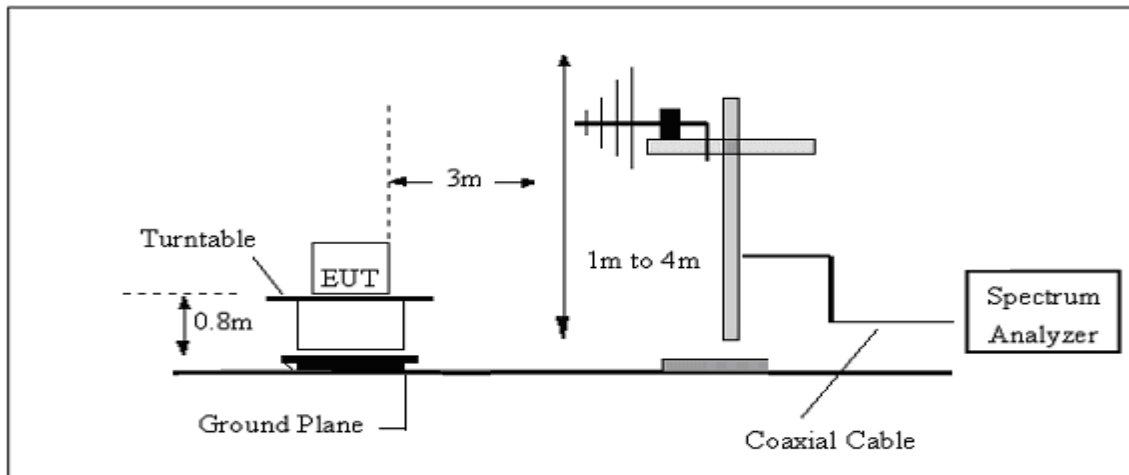



4.4 TEST RESULTS

Temperature :	25 °C	Relative Humidity :	50%
Pressure :	1012 hPa	Test Voltage :	AC 120V/60Hz
Test Mode :	TX Mode		

4.4.1 Spurious Radiated Emission Below 30 MHz

Frequency	Reading	Detector	Ant. Factor	Cable	Emission	Limits	Margin
(KHz)	(dB μ V)	(PK/QP/AV)	(dB/m)	Loss	Level (dB μ V/m)	(dB μ V/m)	(dB)
9	63.76	AV	28.16	0.1	92.02	128.52	-36.50
23	62.15	AV	28.21	0.1	90.46	120.37	-29.91
36	55.37	AV	22.03	0.1	77.50	116.48	-38.98
45	57.18	AV	21.25	0.1	78.53	114.54	-36.01
110	61.82	AV	10.04	0.1	71.96	106.78	-34.82
175	73.68	AV	9.57	0.1	83.35	102.74	-19.39
205	61.89	AV	9.43	0.1	71.42	101.37	-29.95
554	55.27	QP	-16.36	0.1	39.01	72.73	-33.72
23214	42.65	QP	-17.90	0.9	25.65	53.98	-28.33

1. “*” Means Fundamental frequency

2. Emission Level [dB μ V/m] = Reading [dB μ V] + Ant. Factor [dB/m] + Cable Loss [dB]

3. Margin [dB] = Emission Level [dB μ V/m] – Limit [dB μ V/m]

4. Limit calculation: Limit at specified distance + 40log (300/3) = Limit + 80 dB for up to 0.49 MHz

Limit at specified distance + 40log (30/3) = Limit + 40 dB for above 0.49 MHz, Below 30 MHz

4.4.2 Spurious Radiated Emission below 1 GHz

Temperature :	25 °C	Relative Humidity :	50%
Pressure :	1012 hPa	Test Voltage :	AC 120V/60Hz
Test Mode :	Mode 1		

The following table shows the highest levels of radiated emissions on polarizations of Horizontal

Frequency (MHz)	Reading (dBuV)	Correct Factor(dB/m)	Result (dBuV/m)	Limit (dBuV/m)	Margin (dB)	Remark
52.0251	36.82	-22.06	14.76	40.00	-25.24	QP
68.1514	40.92	-24.15	16.77	40.00	-23.23	QP
133.1511	39.75	-17.54	22.21	43.50	-21.29	QP
351.7080	39.21	-13.51	25.70	46.00	-20.30	QP
392.0951	36.47	-11.77	24.70	46.00	-21.30	QP
750.1083	29.86	-3.56	26.30	46.00	-19.70	QP

Remark:

1. Margin = Result (Result =Reading + Factor) –Limit





Temperature :	25 °C	Relative Humidity :	50%
Pressure :	1012 hPa	Test Voltage :	AC 120V/60Hz
Test Mode :	Mode 1		

The following table shows the highest levels of radiated emissions on polarizations of vertical

Frequency (MHz)	Reading (dBuV)	Correct Factor(dB/m)	Result (dBuV/m)	Limit (dBuV/m)	Margin (dB)	Remark
38.7518	36.72	-15.68	21.04	40.00	-18.96	QP
67.9130	39.47	-24.15	15.32	40.00	-24.68	QP
123.6985	40.77	-17.64	23.13	43.50	-20.37	QP
379.9141	43.03	-12.63	30.40	46.00	-15.60	QP
726.8052	31.70	-4.26	27.44	46.00	-18.56	QP
903.3094	31.12	-2.14	28.98	46.00	-17.02	QP

Remark:

1. Margin = Result (Result =Reading + Factor)–Limit

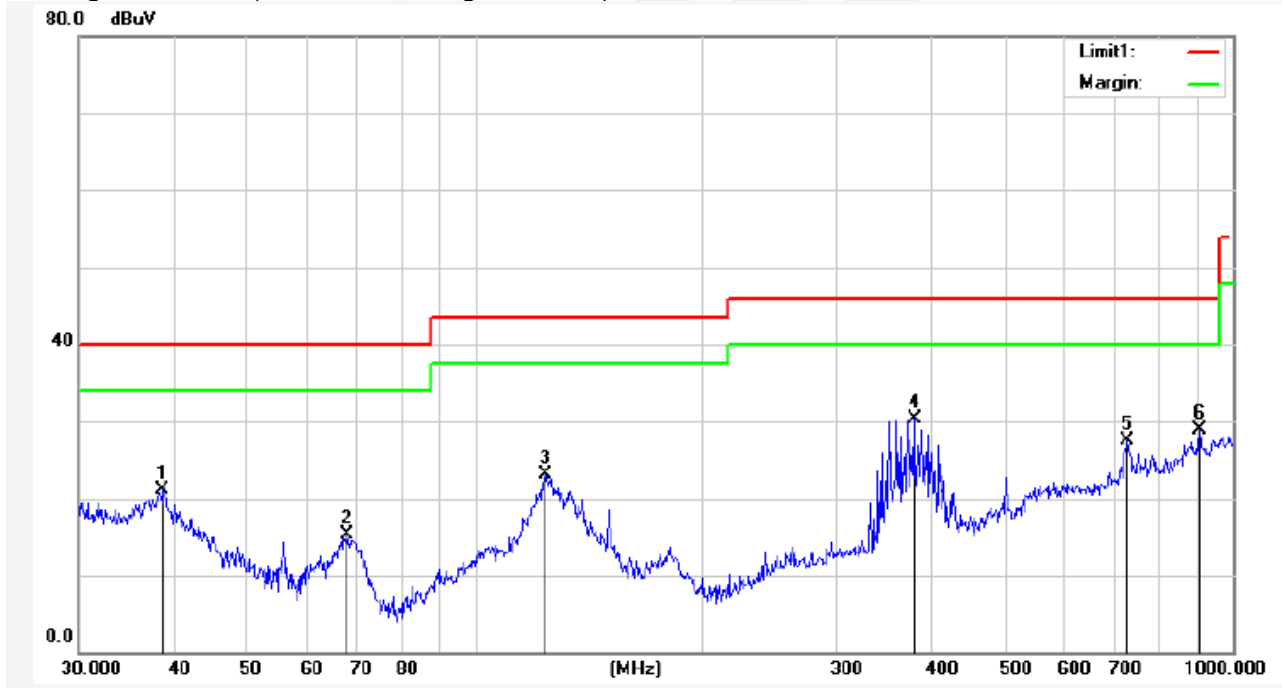

APPENDIX-PHOTOS OF TEST SETUP

Radiated emission Measurement Photos(9KHz-30MHz)

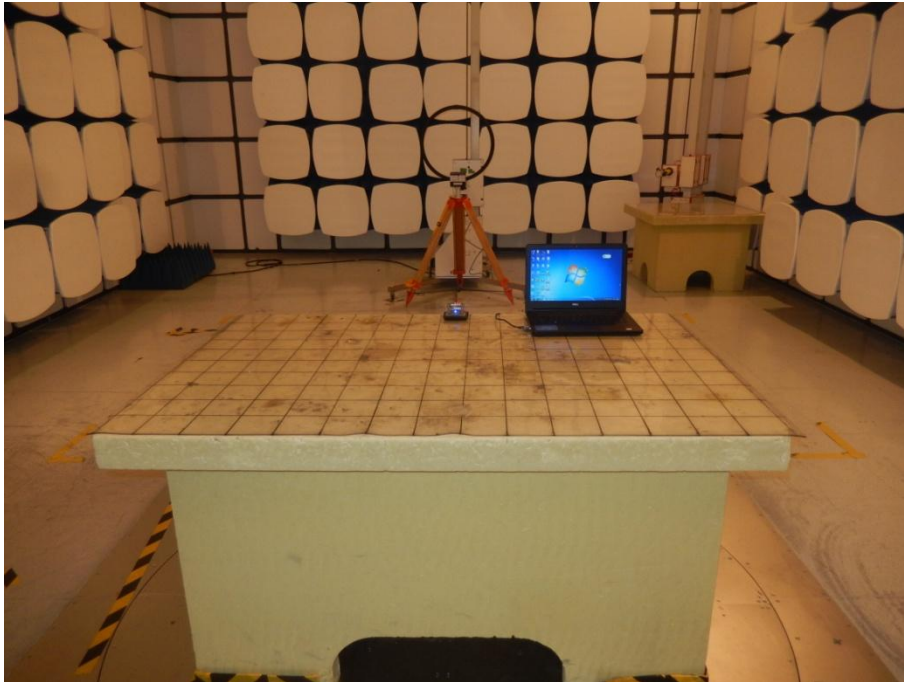

Radiated emission Measurement Photos(30MHz-1000MHz)

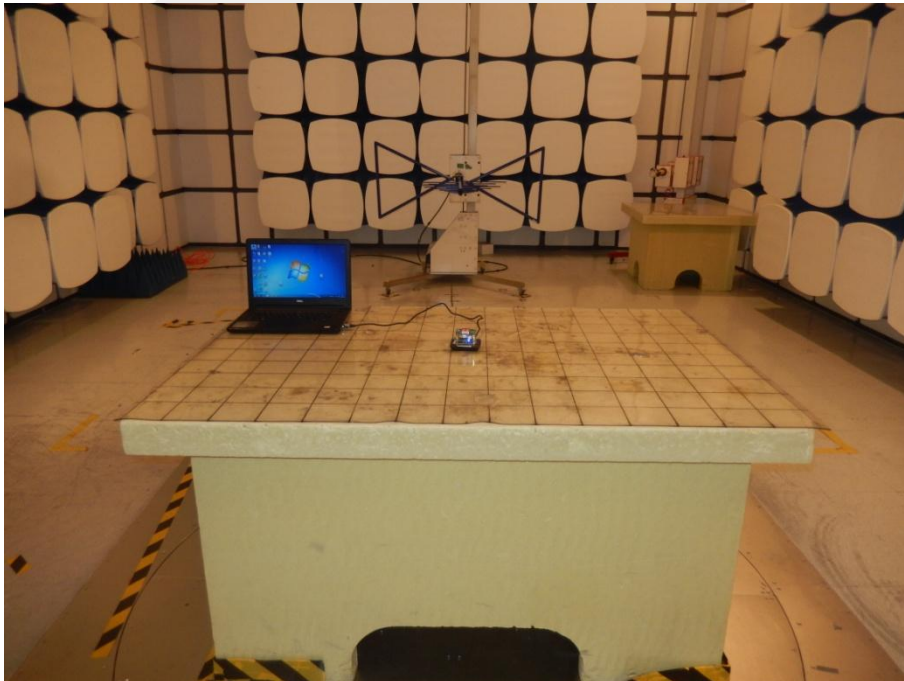

Conduction Measurement Photos

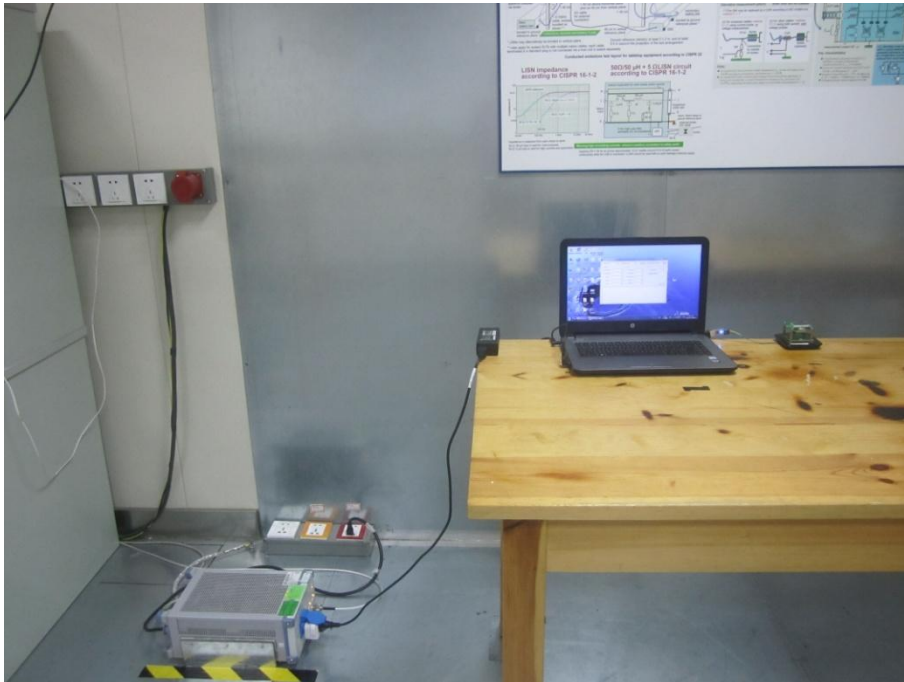

※※※※※END OF THE REPORT※※※※※