

FCC Test Report

Report No.: RF160719C17K

FCC ID: 2AKCZ-0D0

Model: APL45-0D0

Received Date: Mar. 16, 2018

Test Date: Mar. 28 ~ Apr. 04, 2018

Issued Date: Jun. 04, 2018

Applicant: SonicWall Inc.

Address: 1033 McCarthy Blvd., Milpitas, CA 95035, USA

Issued By: Bureau Veritas Consumer Products Services (H.K.) Ltd., Taoyuan Branch

Lab Address: No. 47-2, 14th Ling, Chia Pau Vil., Lin Kou Dist., New Taipei City, Taiwan, R.O.C.

Test Location: No. 19, Hwa Ya 2nd Rd., Wen Hwa Vil., Kwei Shan Dist., Taoyuan City 33383, TAIWAN (R.O.C.)

**FCC Registration /
Designation Number:** 788550 / TW0003



This report is for your exclusive use. Any copying or replication of this report to or for any other person or entity, or use of our name or trademark, is permitted only with our prior written permission. This report sets forth our findings solely with respect to the test samples identified herein. The results set forth in this report are not indicative or representative of the quality or characteristics of the lot from which a test sample was taken or any similar or identical product unless specifically and expressly noted. Our report includes all of the tests requested by you and the results thereof based upon the information that you provided to us. You have 60 days from date of issuance of this report to notify us of any material error or omission caused by our negligence, provided, however, that such notice shall be in writing and shall specifically address the issue you wish to raise. A failure to raise such issue within the prescribed time shall constitute your unqualified acceptance of the completeness of this report, the tests conducted and the correctness of the report contents. Unless specific mention, the uncertainty of measurement has been explicitly taken into account to declare the compliance or non-compliance to the specification. The report must not be used by the client to claim product certification, approval, or endorsement by TAF or any government agencies.

Table of Contents

Release Control Record	4
1 Certificate of Conformity	5
2 Summary of Test Results	6
2.1 Measurement Uncertainty.....	6
2.2 Modification Record.....	6
3 General Information	7
3.1 General Description of EUT.....	7
3.2 Description of Test Modes.....	10
3.2.1 Test Mode Applicability and Tested Channel Detail.....	11
3.3 Duty Cycle of Test Signal.....	13
3.4 Description of Support Units.....	14
3.4.1 Configuration of System under Test.....	14
3.5 General Description of Applied Standards.....	15
4 Test Types and Results	16
4.1 Radiated Emission and Bandedge Measurement.....	16
4.1.1 Limits of Radiated Emission and Bandedge Measurement.....	16
4.1.2 Test Instruments.....	17
4.1.3 Test Procedures.....	18
4.1.4 Deviation from Test Standard.....	18
4.1.5 Test Setup.....	19
4.1.6 EUT Operating Conditions.....	20
4.1.7 Test Results.....	21
4.2 Conducted Emission Measurement.....	46
4.2.1 Limits of Conducted Emission Measurement.....	46
4.2.2 Test Instruments.....	46
4.2.3 Test Procedures.....	47
4.2.4 Deviation from Test Standard.....	47
4.2.5 Test Setup.....	48
4.2.6 EUT Operating Conditions.....	48
4.2.7 Test Results.....	49
4.3 Transmit Power Measurement.....	53
4.3.1 Limits of Transmit Power Measurement.....	53
4.3.2 Test Setup.....	53
4.3.3 Test Instruments.....	54
4.3.4 Test Procedure.....	54
4.3.5 Deviation from Test Standard.....	54
4.3.6 EUT Operating Conditions.....	54
4.3.7 Test Result.....	55
4.4 Occupied Bandwidth Measurement.....	63
4.4.1 Test Setup.....	63
4.4.2 Test Instruments.....	63
4.4.3 Test Procedure.....	63
4.4.4 Test Results.....	64
4.5 Peak Power Spectral Density Measurement.....	68
4.5.1 Limits of Peak Power Spectral Density Measurement.....	68
4.5.2 Test Setup.....	68
4.5.3 Test Instruments.....	68
4.5.4 Test Procedures.....	68
4.5.5 Deviation from Test Standard.....	68
4.5.6 EUT Operating Conditions.....	68
4.5.7 Test Results.....	69
4.6 Frequency Stability.....	74
4.6.1 Limits of Frequency Stability Measurement.....	74

4.6.2	Test Setup.....	74
4.6.3	Test Instruments	74
4.6.4	Test Procedure	74
4.6.5	Deviation from Test Standard	74
4.6.6	EUT Operating Condition	74
4.6.7	Test Results	75
4.7	6dB Bandwidth Measurement.....	76
4.7.1	Limits of 6dB Bandwidth Measurement.....	76
4.7.2	Test Setup.....	76
4.7.3	Test Instruments	76
4.7.4	Test Procedure	76
4.7.5	Deviation from Test Standard	76
4.7.6	EUT Operating Condition	76
4.7.7	Test Results	77
5	Pictures of Test Arrangements.....	79
	Appendix – Information on the Testing Laboratories	80

Release Control Record

Issue No.	Description	Date Issued
RF160719C17K	Original release	Jun. 04, 2018

1 Certificate of Conformity

Product: Wireless Access Point
Brand: SONICWALL
Test Model: APL45-0D0
Sample Status: Engineering sample
Applicant: SonicWall Inc.
Test Date: Mar. 28 ~ Apr. 04, 2018
Standards: 47 CFR FCC Part 15, Subpart E (Section 15.407)
ANSI C63.10:2013

The above equipment has been tested by **Bureau Veritas Consumer Products Services (H.K.) Ltd., Taoyuan Branch**, and found compliance with the requirement of the above standards. The test record, data evaluation & Equipment Under Test (EUT) configurations represented herein are true and accurate accounts of the measurements of the sample's RF characteristics under the conditions specified in this report.

Prepared by : Pettie Chen , **Date:** Jun. 04, 2018
Pettie Chen / Senior Specialist

Approved by : Bruce Chen , **Date:** Jun. 04, 2018
Bruce Chen / Project Engineer

2 Summary of Test Results

47 CFR FCC Part 15, Subpart E (SECTION 15.407)			
FCC Clause	Test Item	Result	Remarks
15.407(b)(6)	AC Power Conducted Emissions	Pass	Meet the requirement of limit. Minimum passing margin is -8.29dB at 0.32786MHz.
15.407(b) (1/2/3/4/6)	Radiated Emissions & Band Edge Measurement	Pass	Meet the requirement of limit. Minimum passing margin is -1.3dB at 5725.00MHz.
15.407(a)(1/2/3)	Max Average Transmit Power	Pass	Meet the requirement of limit.
15.407(a)(1/2/3)	Peak Power Spectral Density	Pass	Meet the requirement of limit.
15.407(g)	Frequency Stability	Pass	Meet the requirement of limit.
15.203	Antenna Requirement	Pass	Antenna connector is IPEX not a standard connector.

2.1 Measurement Uncertainty

Where relevant, the following measurement uncertainty levels have been estimated for tests performed on the EUT as specified in CISPR 16-4-2:

Measurement	Frequency	Expanded Uncertainty (k=2) (\pm)
Conducted Emissions at mains ports	150kHz ~ 30MHz	2.94 dB
Radiated Emissions up to 1 GHz	30MHz ~ 200MHz	3.86 dB
	200MHz ~ 1000MHz	3.87 dB
Radiated Emissions above 1 GHz	1GHz ~ 18GHz	2.29 dB
	18GHz ~ 40GHz	2.29 dB

2.2 Modification Record

There were no modifications required for compliance.

3 General Information

3.1 General Description of EUT

Product	Wireless Access Point
Brand	SONICWALL
Test Model	APL45-0D0
Status of EUT	Engineering sample
Power Supply Rating	12Vdc (Adapter) 48~55Vdc (POE)
Modulation Type	256QAM, 64QAM, 16QAM, QPSK, BPSK
Modulation Technology	OFDM
Transfer Rate	802.11a: 54.0/ 48.0/ 36.0/ 24.0/ 18.0/ 12.0/ 9.0/ 6.0Mbps 802.11n: up to 300.0Mbps 802.11ac: up to 867Mbps
Operating Frequency	5250 ~ 5350MHz, 5470 ~ 5725MHz
Number of Channel	5250 ~ 5350MHz: 4 for 802.11a, 802.11n (HT20), 802.11ac (VHT20) 2 for 802.11n (HT40), 802.11ac (VHT40) 1 for 802.11ac (VHT80) 5470 ~ 5725MHz: 12 for 802.11a, 802.11n (HT20), 802.11ac (VHT20) 6 for 802.11n (HT40), 802.11ac (VHT40) 3 for 802.11ac (VHT80)
Output Power	CDD Mode: 5250 ~ 5350MHz: 190.789mW 5470 ~ 5725MHz: 173.250mW Beamforming Mode: 5250 ~ 5350MHz: 95.401mW 5470 ~ 5725MHz: 86.631mW
Antenna Type	Refer to Note
Antenna Connector	Refer to Note
Accessory Device	Adapter
Data Cable Supplied	NA

Note:

1. This report is prepared for FCC class II permissive change. This report is issued as a supplementary report of the original report no.: RF160719C17H-1. The difference compared with original report is adding 5.25GHz to 5.35GHz and 5.47GHz to 5.725GHz by software.

2. The EUT incorporates a MIMO function. Physically, the EUT provides 2 completed transmitters and 2 receivers.

Modulation Mode	TX Function	Beamforming
802.11a	2TX	Not Support
802.11n (HT20)	2TX	Support
802.11n (HT40)	2TX	Support
802.11ac (VHT20)	2TX	Support
802.11ac (VHT40)	2TX	Support
802.11ac (VHT80)	2TX	Support

*The modulation and bandwidth are similar for 802.11n mode for HT20/HT40 and 802.11ac mode for VHT20/VHT40, therefore investigated worst case to representative mode in test report. (Final test mode refer section 3.2.1)

* For 5GHz band, CDD mode is the worst case for final radiated emission below 1GHz and power line conducted emission tests after pretesting CDD mode and beamforming mode.

3. The EUT with follow antennas gain is listed as table below.

Ant. No.	1	2	3	4	BT
Ant. Type	PIFA				
Frequency (MHz)	2400-2500		5150-5850		2400-2500
Gain (dBi)	3.67	4.31	5.72	5.99	3.51
Connector	IPEX				

4. The EUT consumes power from the following Adapter and POE. (Support unit only)

Adapter (Support unit)	
Brand	Powertron Electronics Corp.
Model	PA1024-120HUB200
Input Power	100-240Vac~50-60Hz 0.6A
Output Power	12Vdc / 2.0A 24W Max.
Power Line	1.5m non-shielded power cable with one core

POE (Support unit)	
Brand	DELL
Model	ADPE01-0B1
Input Power	100-240Vac~0.6A 50-60Hz
Output Power	52Vdc, 0.58A
Power Line	1.7m non-shielded power cable without core

5. WLAN 2.4GHz, 5GHz and BT LE technology can transmit at same time.
6. Spurious emission of the simultaneous operation (WLAN 2.4GHz, 5GHz, BT LE) has been evaluated and no non-compliance was found.

7. The power settings are listed as below.

CDD Mode						
	802.11a	802.11n (HT20)		802.11n (HT40)		802.11ac (VHT80)
CH 52	17	17	CH 54	20	CH 58	14.5
CH 60	17	17	CH 62	17	CH 106	15
CH 64	17	17.5	CH 102	15	CH 138 For 5500~5720MHz	20
CH 100	17	18	CH 110	20	CH 138 For 5720~5825MHz	20
CH 116	17	17.5	CH 134	19.5		
CH 140	17	18.5	CH 142 For 5500~5720MHz	20		
CH 144 For 5500~5720MHz	19.5	18	CH 142 For 5720~5825MHz	20		
CH 144 For 5720~5825MHz	19.5	18				
Beamforming Mode						
	802.11n (HT20)		802.11n (HT40)		802.11ac (VHT80)	
CH 52	17	CH 54	20	CH 58	14.5	
CH 60	17	CH 62	17	CH 106	15	
CH 64	17.5	CH 102	15	CH 138 For 5500~5720MHz	20	
CH 100	18	CH 110	20	CH 138 For 5720~5825MHz	20	
CH 116	17.5	CH 134	19.5			
CH 140	18.5	CH 142 For 5500~5720MHz	20			
CH 144 For 5500~5720MHz	18	CH 142 For 5720~5825MHz	20			
CH 144 For 5720~5825MHz	18					

3.2 Description of Test Modes

For 5250 ~ 5350MHz

4 channels are provided for 802.11a, 802.11n (HT20), 802.11ac (VHT20):

Channel	Frequency	Channel	Frequency
52	5260 MHz	60	5300 MHz
56	5280 MHz	64	5320 MHz

2 channels are provided for 802.11n (HT40), 802.11ac (VHT40):

Channel	Frequency	Channel	Frequency
54	5270 MHz	62	5310 MHz

1 channel is provided for 802.11ac (VHT80):

Channel	Frequency
58	5290 MHz

For 5470 ~ 5725MHz

12 channels are provided for 802.11a, 802.11n (HT20), 802.11ac (VHT20):

Channel	Frequency	Channel	Frequency
100	5500 MHz	124	5620 MHz
104	5520 MHz	128	5640 MHz
108	5540 MHz	132	5660 MHz
112	5560 MHz	136	5680 MHz
116	5580 MHz	140	5700 MHz
120	5600 MHz	144	5720 MHz

6 channels are provided for 802.11n (HT40), 802.11ac (VHT40):

Channel	Frequency	Channel	Frequency
102	5510 MHz	126	5630 MHz
110	5550 MHz	134	5670 MHz
118	5590 MHz	142	5710 MHz

3 channels are provided for 802.11ac (VHT80):

Channel	Frequency	Channel	Frequency
106	5530 MHz	122	5610 MHz
138	5690 MHz		

3.2.1 Test Mode Applicability and Tested Channel Detail

EUT CONFIGURE MODE	APPLICABLE TO				DESCRIPTION
	RE \geq 1G	RE<1G	PLC	APCM	
A	√	√	√	√	Power from Adapter
B	-	√	√	-	Power from PoE

Where **RE \geq 1G**: Radiated Emission above 1GHz & Bandedge Measurement
RE<1G: Radiated Emission below 1GHz
PLC: Power Line Conducted Emission
APCM: Antenna Port Conducted Measurement

Note:

- The EUT had been pre-tested on the positioned of each 3 axis.
The worst case was found when positioned on **Z-plane**.
- "-" means no effect.

Radiated Emission Test (Above 1GHz):

- Pre-Scan has been conducted to determine the worst-case mode from all possible combinations between available modulations, data rates and antenna ports (if EUT with antenna diversity architecture).
- Following channel(s) was (were) selected for the final test as listed below.

EUT Configure Mode	Mode	Frequency Band (MHz)	Available Channel	Tested Channel	Modulation Technology	Data Rate (Mbps)
A	802.11a	5250-5350	52 to 64	52, 60, 64	OFDM	6.0
	802.11n (HT20)		52 to 64	52, 60, 64	OFDM	6.5
	802.11n (HT40)		54 to 62	54, 62	OFDM	13.5
	802.11ac (VHT80)		58	58	OFDM	58.5
A	802.11a	5470-5725	100 to 144	100, 116, 140, 144	OFDM	6.0
	802.11n (HT20)		100 to 144	100, 116, 140, 144	OFDM	6.5
	802.11n (HT40)		102 to 142	102, 110, 134, 142	OFDM	13.5
	802.11ac (VHT80)		106 to 138	106, 122, 138	OFDM	58.5

Radiated Emission Test (Below 1GHz):

- Pre-Scan has been conducted to determine the worst-case mode from all possible combinations between available modulations, data rates and antenna ports (if EUT with antenna diversity architecture).
- Following channel(s) was (were) selected for the final test as listed below.

EUT Configure Mode	Mode	Frequency Band (MHz)	Available Channel	Tested Channel	Modulation Technology	Data Rate (Mbps)
A, B	802.11a	5250-5350	52 to 64	52	OFDM	6.0
		5470-5725	100 to 140		OFDM	6.0

Power Line Conducted Emission Test:

- Pre-Scan has been conducted to determine the worst-case mode from all possible combinations between available modulations, data rates and antenna ports (if EUT with antenna diversity architecture).
- Following channel(s) was (were) selected for the final test as listed below.

EUT Configure Mode	Mode	Frequency Band (MHz)	Available Channel	Tested Channel	Modulation Technology	Data Rate (Mbps)
A, B	802.11a	5250-5350	52 to 64	52	OFDM	6.0
		5470-5725	100 to 140		OFDM	6.0

Antenna Port Conducted Measurement:

- This item includes all test value of each mode, but only includes spectrum plot of worst value of each mode.
- Pre-Scan has been conducted to determine the worst-case mode from all possible combinations between available modulations, data rates and antenna ports (if EUT with antenna diversity architecture).
- Following channel(s) was (were) selected for the final test as listed below.

EUT Configure Mode	Mode	Frequency Band (MHz)	Available Channel	Tested Channel	Modulation Technology	Data Rate (Mbps)
A	802.11a	5250-5350	52 to 64	52, 60, 64	OFDM	6.0
	802.11n (HT20)		52 to 64	52, 60, 64	OFDM	6.5
	802.11n (HT40)		54 to 62	54, 62	OFDM	13.5
	802.11ac (VHT80)		58	58	OFDM	58.5
A	802.11a	5470-5725	100 to 144	100, 116, 140, 144	OFDM	6.0
	802.11n (HT20)		100 to 144	100, 116, 140, 144	OFDM	6.5
	802.11n (HT40)		102 to 142	102, 110, 134, 142	OFDM	13.5
	802.11ac (VHT80)		106 to 138	106, 122, 138	OFDM	58.5

Test Condition:

APPLICABLE TO	ENVIRONMENTAL CONDITIONS	INPUT POWER	TESTED BY
RE\geq1G	25deg. C, 64%RH	120Vac, 60Hz	Willy Cheng
RE$<$1G	21deg. C, 67%RH	120Vac, 60Hz 52Vdc	Adair Peng
PLC	25deg. C, 75%RH	120Vac, 60Hz 52Vdc	Adair Peng
APCM	25deg. C, 60%RH	120Vac, 60Hz	Antony Lee

3.3 Duty Cycle of Test Signal

Duty cycle of test signal is > 98%, duty factor is not required.

Duty cycle of test signal is < 98 %, duty factor is required.

802.11a: Duty cycle = $2.007/2.119 = 0.947$, Duty factor = $10 * \log(1/0.947) = 0.24$

802.11n (HT20): Duty cycle = $4.940/5.042 = 0.980$

802.11n (HT40): Duty cycle = $2.395/2.493 = 0.961$, Duty factor = $10 * \log(1/0.961) = 0.17$

802.11ac (VHT80): Duty cycle = $1.127/1.227 = 0.919$, Duty factor = $10 * \log(1/0.919) = 0.37$

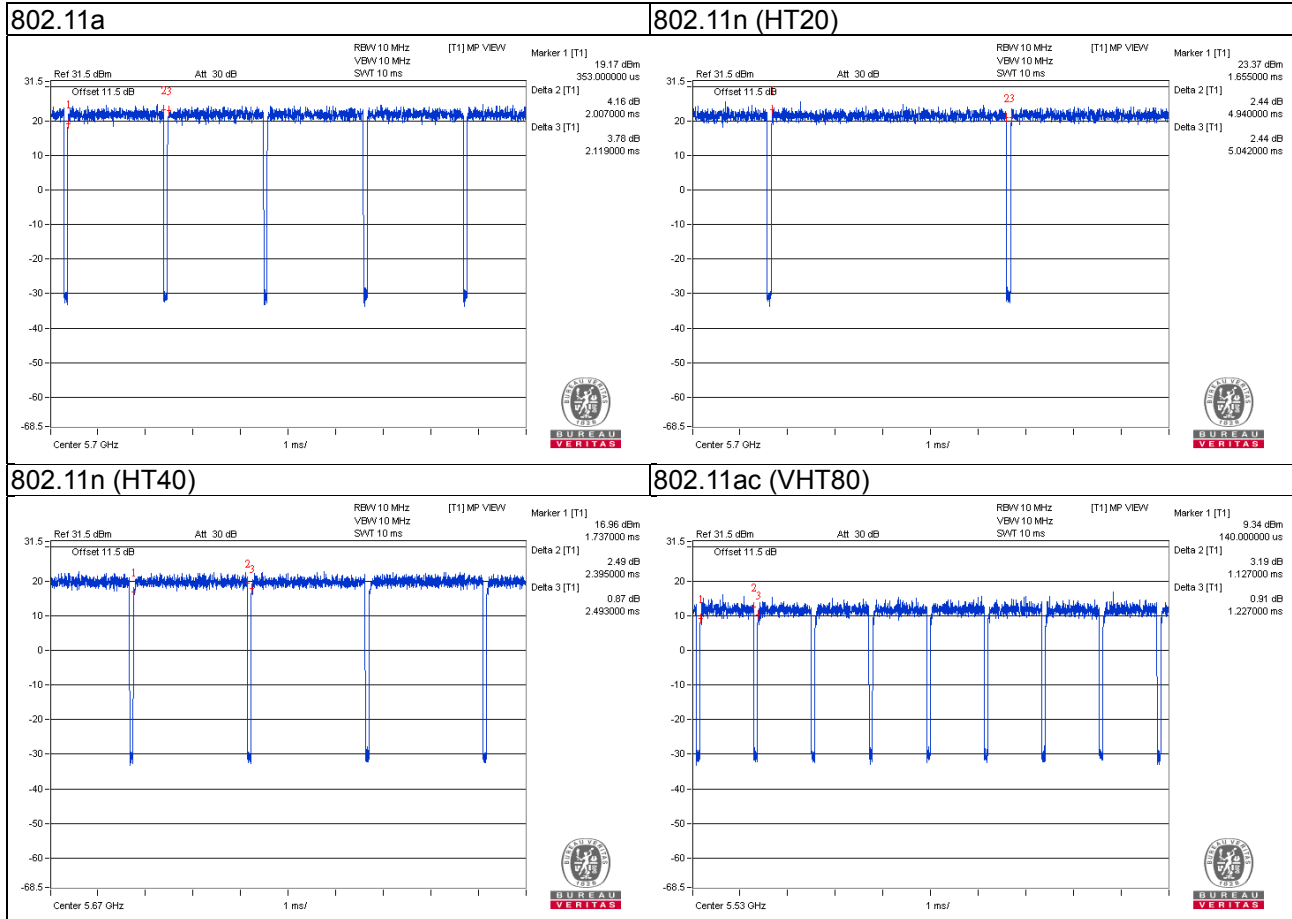

3.4 Description of Support Units

The EUT has been tested as an independent unit together with other necessary accessories or support units. The following support units or accessories were used to form a representative test configuration during the tests.

ID	Product	Brand	Model No.	Serial No.	FCC ID	Remarks
A.	Notebook	DELL	E5410	1HC2XM1	FCC DoC Approved	-
B.	Adapter	Powertron Electronics Corp.	PA1024-120HUB200	N/A	N/A	Provided by manufacturer
C.	POE	DELL	ADPE01-0B1	N/A	N/A	Provided by manufacturer
D.	Load	N/A	N/A	N/A	N/A	-

Note:

1. All power cords of the above support units are non-shielded (1.8m).
2. Item A acted as communication partner to transfer data.

ID	Descriptions	Qty.	Length (m)	Shielding (Yes/No)	Cores (Qty.)	Remarks
1.	RJ45 Cable	4	1.5	N	0	Cat5e
2.	RJ45 Cable	1	3	N	0	Cat5e
3.	Power Cable	1	1.5	N	1	-
4.	RJ45 Cable	1	1.5	N	0	Cat5e

3.4.1 Configuration of System under Test

Test Mode A

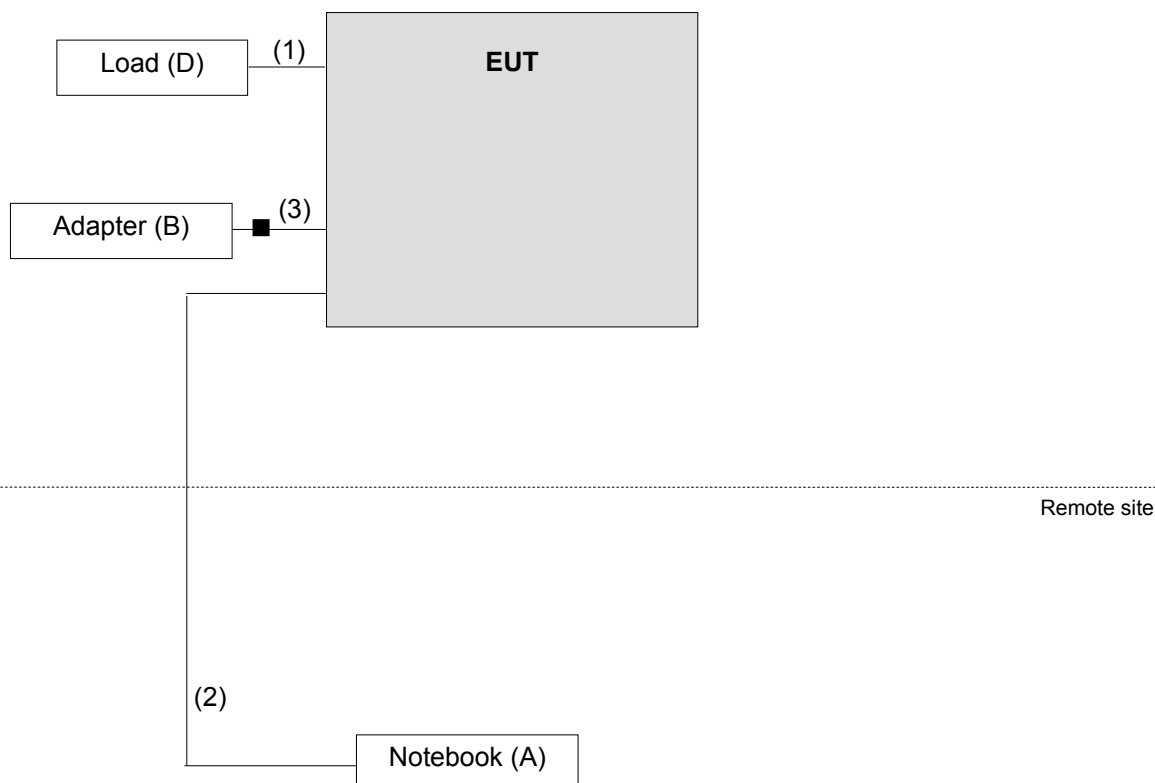

Test Mode B
For all tests except Conducted Emission Test

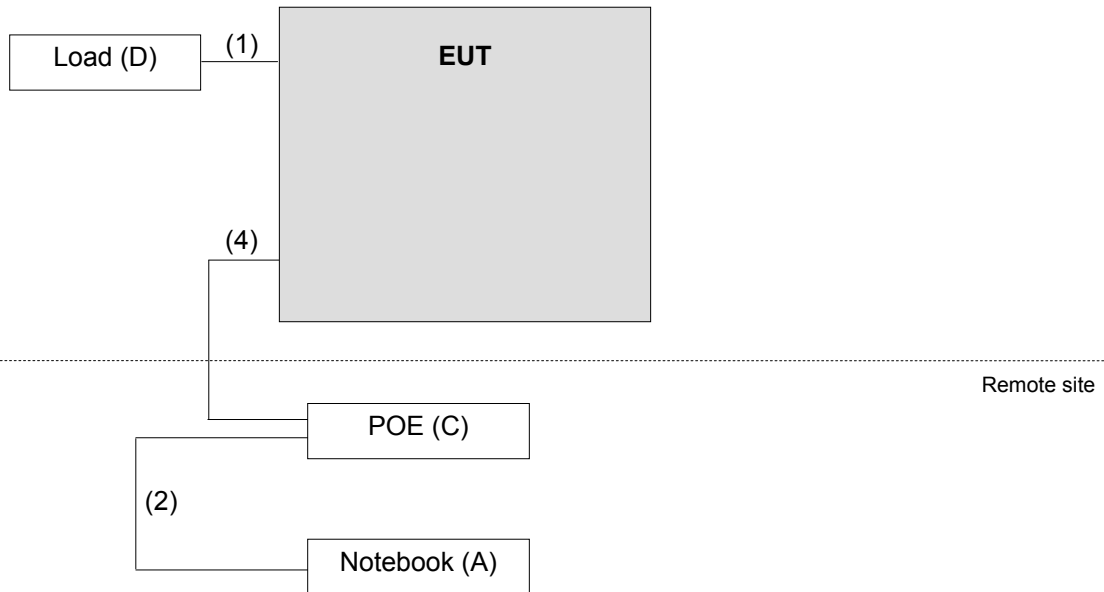

Conducted Emission Test

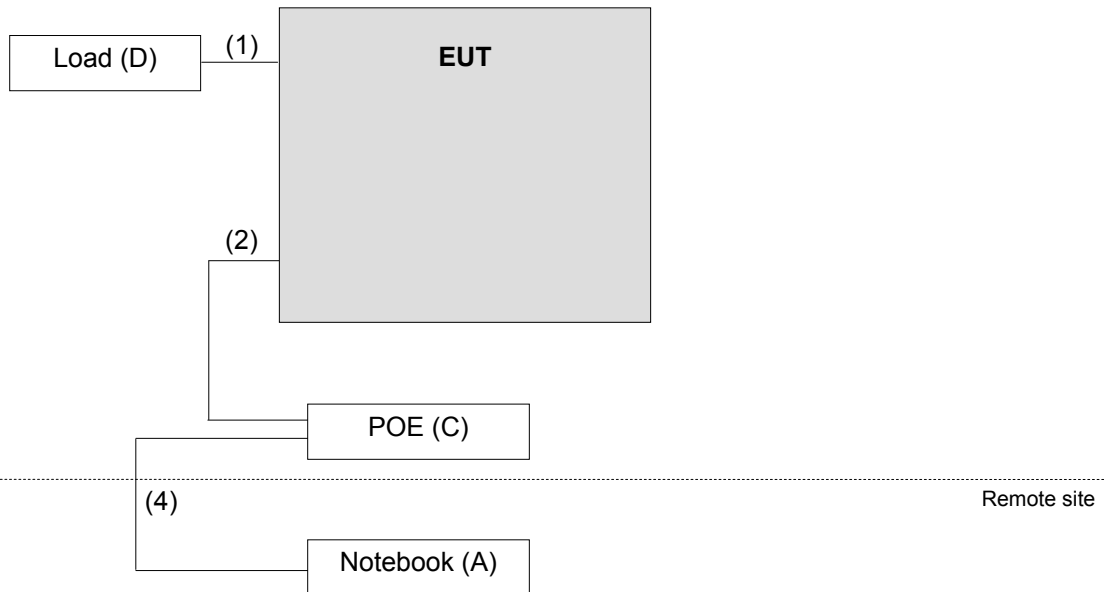

3.5 General Description of Applied Standards

The EUT is a RF Product. According to the specifications of the manufacturer, it must comply with the requirements of the following standards:

FCC Part 15, Subpart E (15.407)
KDB 789033 D02 General UNII Test Procedures New Rules v02r01
KDB 662911 D01 Multiple Transmitter Output v02r01
 ANSI C63.10-2013

All test items have been performed and recorded as per the above standards.

4 Test Types and Results

4.1 Radiated Emission and Bandedge Measurement

4.1.1 Limits of Radiated Emission and Bandedge Measurement

Radiated emissions which fall in the restricted bands must comply with the radiated emission limits specified as below table.

Frequencies (MHz)	Field Strength (microvolts/meter)	Measurement Distance (meters)
0.009 ~ 0.490	2400/F(kHz)	300
0.490 ~ 1.705	24000/F(kHz)	30
1.705 ~ 30.0	30	30
30 ~ 88	100	3
88 ~ 216	150	3
216 ~ 960	200	3
Above 960	500	3

NOTE:

1. The lower limit shall apply at the transition frequencies.
2. Emission level (dBuV/m) = 20 log Emission level (uV/m).
3. For frequencies above 1000MHz, the field strength limits are based on average detector, however, the peak field strength of any emission shall not exceed the maximum permitted average limits, specified above by more than 20dB under any condition of modulation.

Limits of Unwanted Emission Out of the Restricted Bands

Applicable To		Limit	
789033 D02 General UNII Test Procedure New Rules v02r01		Field Strength at 3m	
		PK:74 (dBµV/m)	AV:54 (dBµV/m)
Frequency Band	Applicable To	EIRP Limit	Equivalent Field Strength at 3m
5150~5250 MHz	15.407(b)(1)	PK:-27 (dBm/MHz)	PK:68.2(dBµV/m)
5250~5350 MHz	15.407(b)(2)		
5470~5725 MHz	15.407(b)(3)		
5725~5850 MHz	<input checked="" type="checkbox"/> 15.407(b)(4)(i)	PK:-27 (dBm/MHz) ^{*1} PK:10 (dBm/MHz) ^{*2} PK:15.6 (dBm/MHz) ^{*3} PK:27 (dBm/MHz) ^{*4}	PK: 68.2 (dBµV/m) ^{*1} PK:105.2 (dBµV/m) ^{*2} PK: 110.8 (dBµV/m) ^{*3} PK:122.2 (dBµV/m) ^{*4}
	<input type="checkbox"/> 15.407(b)(4)(ii)	Emission limits in section 15.247(d)	
^{*1} beyond 75 MHz or more above of the band edge. ^{*3} below the band edge increasing linearly to a level of 15.6 dBm/MHz at 5 MHz above.		^{*2} below the band edge increasing linearly to 10 dBm/MHz at 25 MHz above. ^{*4} from 5 MHz above or below the band edge increasing linearly to a level of 27 dBm/MHz at the band edge.	

NOTE: The following formula is used to convert the equipment isotropic radiated power (eirp) to field strength:

$$E = \frac{1000000\sqrt{30P}}{3} \mu\text{V/m, where P is the eirp (Watts).}$$

4.1.2 Test Instruments

Description & Manufacturer	Model No.	Serial No.	Cal. Date	Cal. Due
Test Receiver ROHDE & SCHWARZ	ESIB7	100187	May 02, 2017	May 01, 2018
Spectrum Analyzer ROHDE & SCHWARZ	FSP40	100041	Dec. 12, 2017	Dec. 11, 2018
BILOG Antenna SCHWARZBECK	VULB9168	9168-171	Dec. 11, 2017	Dec. 10, 2018
HORN Antenna SCHWARZBECK	9120D	209	Dec. 13, 2017	Dec. 12, 2018
HORN Antenna SCHWARZBECK	BBHA 9170	BBHA9170241	Dec. 01, 2017	Nov. 30, 2018
Loop Antenna EMCI	EM-6879	269	Aug. 11, 2017	Aug. 10, 2018
Preamplifier Agilent (Below 1GHz)	8447D	2944A10738	Aug. 21, 2017	Aug. 20, 2018
Preamplifier Agilent (Above 1GHz)	8449B	3008A01922	Sep. 15, 2017	Sep. 14, 2018
RF signal cable HUBER+SUHNER	SUCOFLEX 104	Cable-CH3-03 (223653/4)	Aug. 21, 2017	Aug. 20, 2018
RF signal cable HUBER+SUHNER& EMCI	SUCOFLEX 104&EMC104-SM-SM- 8000	Cable-CH3-03 (309224+170907)	Sep.11, 2017	Sep. 10, 2018
Software BV ADT	ADT_Radiated_ V7.6.15.9.5	NA	NA	NA
Antenna Tower inn-co GmbH	MA 4000	013303	NA	NA
Antenna Tower Controller BV ADT	AT100	AT93021702	NA	NA
Turn Table BV ADT	TT100	TT93021702	NA	NA
Turn Table Controller BV ADT	SC100	SC93021702	NA	NA
Boresight Antenna Fixture	FBA-01	FBA-SIP01	NA	NA
26GHz ~ 40GHz Amplifier Agilent	8449B	3008A1960	Aug. 08, 2017	Aug. 07, 2018
High Speed Peak Power Meter	ML2495A	0824012	Aug. 18, 2017	Aug. 17, 2018
Power Sensor	MA2411B	0738171	Aug. 18, 2017	Aug. 17, 2018

- Note:
1. The calibration interval of the above test instruments is 12 months and the calibrations are traceable to NML/ROC and NIST/USA.
 2. The test was performed in HwaYa Chamber 3.
 3. The horn antenna and preamplifier (model: 8449B) are used only for the measurement of emission frequency above 1GHz if tested.
 4. The FCC Designation Number is TW0003. The number will be varied with the Lab location and scope as attached.
 5. The IC Site Registration No. is IC 7450F-3.

4.1.3 Test Procedures

For Radiated emission below 30MHz

- a. The EUT was placed on the top of a rotating table 0.8 meters above the ground at a 3 meter chamber room. The table was rotated 360 degrees to determine the position of the highest radiation.
- b. The EUT was set 3 meters away from the interference-receiving antenna, which was mounted on the top of a variable-height antenna tower.
- c. Both X and Y axes of the antenna are set to make the measurement.
- d. For each suspected emission, the EUT was arranged to its worst case and the rotatable table was turned from 0 degrees to 360 degrees to find the maximum reading.
- e. The test-receiver system was set to Quasi-Peak Detect Function and Specified Bandwidth with Maximum Hold Mode.

NOTE:

1. The resolution bandwidth and video bandwidth of test receiver/spectrum analyzer is 9kHz at frequency below 30MHz.

For Radiated emission above 30MHz

- a. The EUT was placed on the top of a rotating table 0.8 meters (for 30MHz ~ 1GHz) / 1.5 meters (for above 1GHz) above the ground at 3 meter chamber room for test. The table was rotated 360 degrees to determine the position of the highest radiation.
- b. The EUT was set 3 meters away from the interference-receiving antenna, which was mounted on the top of a variable-height antenna tower.
- c. The height of antenna is varied from one meter to four meters above the ground to determine the maximum value of the field strength. Both horizontal and vertical polarizations of the antenna are set to make the measurement.
- d. For each suspected emission, the EUT was arranged to its worst case and then the antenna was tuned to heights from 1 meter to 4 meters and the rotatable table was turned from 0 degrees to 360 degrees to find the maximum reading.
- e. The test-receiver system was set to quasi-peak detect function and specified bandwidth with maximum hold mode when the test frequency is below 1 GHz.
- f. The test-receiver system was set to peak and average detect function and specified bandwidth with maximum hold mode when the test frequency is above 1 GHz. If the peak reading value also meets average limit, measurement with the average detector is unnecessary.

Note:

1. The resolution bandwidth and video bandwidth of test receiver/spectrum analyzer is 120kHz for Quasi-peak detection (QP) at frequency below 1GHz.
2. The resolution bandwidth of test receiver/spectrum analyzer is 1 MHz and the video bandwidth is 3 MHz for Peak detection (PK) at frequency above 1GHz.
3. The resolution bandwidth of test receiver/spectrum analyzer is 1MHz and the video bandwidth is $\geq 1/T$ (Duty cycle < 98%) or 10Hz (Duty cycle $\geq 98\%$) for Average detection (AV) at frequency above 1GHz.
4. All modes of operation were investigated and the worst-case emissions are reported.

4.1.4 Deviation from Test Standard

No deviation.

4.1.5 Test Setup

For Radiated emission below 30MHz

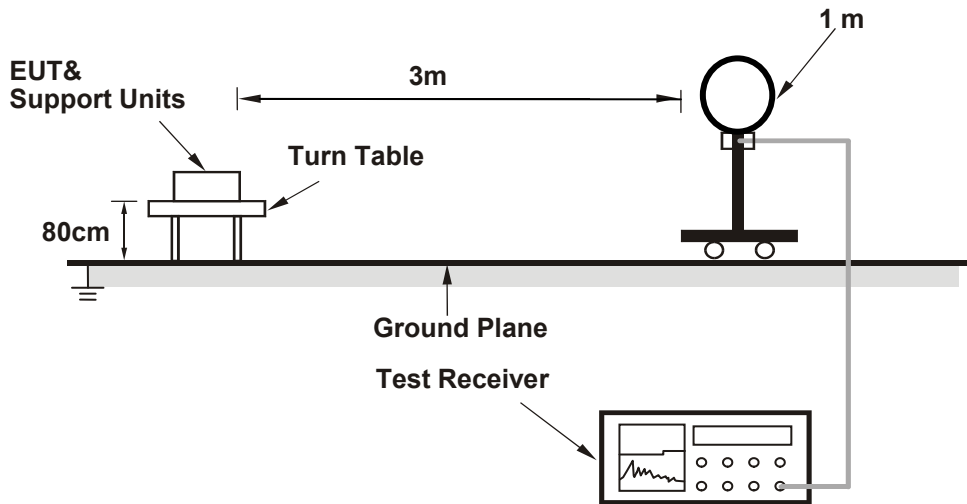

For Radiated emission 30MHz to 1GHz

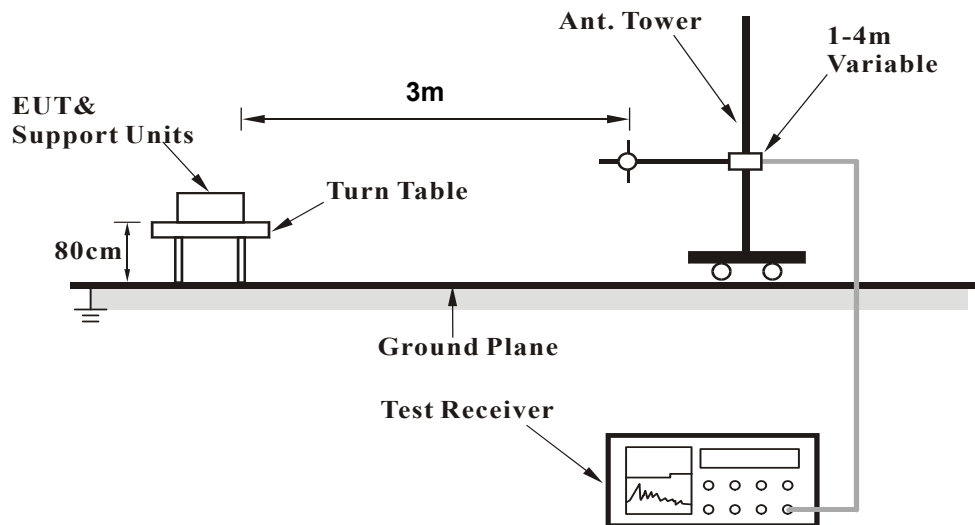

For Radiated emission above 1GHz

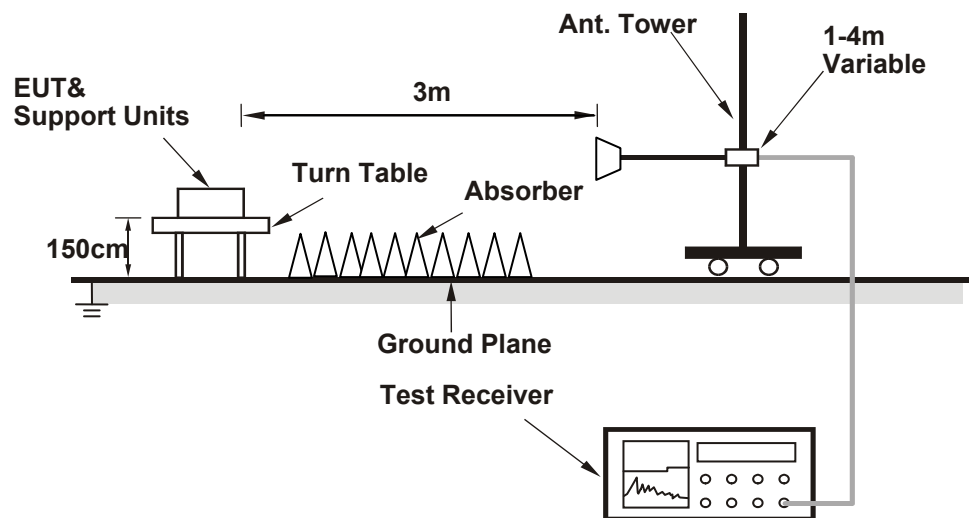

For the actual test configuration, please refer to the attached file (Test Setup Photo).

4.1.6 EUT Operating Conditions

- Placed the EUT on the testing table.
- Prepared a notebook to act as a communication partner and placed it outside of testing area.
- The communication partner connected with EUT via a RJ45 cable and ran a test program (provided by manufacturer) to enable EUT under transmission condition continuously at specific channel frequency.
- The communication partner sent data to EUT by command "PING".

4.1.7 Test Results

Above 1GHz data:

802.11a

CHANNEL	TX Channel 52	DETECTOR	Peak (PK)
FREQUENCY RANGE	1GHz ~ 40GHz	FUNCTION	Average (AV)

ANTENNA POLARITY & TEST DISTANCE: HORIZONTAL AT 3 M

NO.	FREQ. (MHz)	EMISSION LEVEL (dBuV/m)	LIMIT (dBuV/m)	MARGIN (dB)	ANTENNA HEIGHT (m)	TABLE ANGLE (Degree)	RAW VALUE (dBuV)	CORRECTION FACTOR (dB/m)
1	5150.00	55.7 PK	74.0	-18.3	2.16 H	308	52.0	3.7
2	5150.00	45.1 AV	54.0	-8.9	2.16 H	308	41.4	3.7
3	*5260.00	118.4 PK			1.98 H	359	79.0	39.4
4	*5260.00	108.1 AV			1.98 H	359	68.7	39.4
5	#10520.00	58.8 PK	74.0	-15.2	2.83 H	231	42.0	16.8
6	#10520.00	45.5 AV	54.0	-8.5	2.83 H	231	28.7	16.8

ANTENNA POLARITY & TEST DISTANCE: VERTICAL AT 3 M

NO.	FREQ. (MHz)	EMISSION LEVEL (dBuV/m)	LIMIT (dBuV/m)	MARGIN (dB)	ANTENNA HEIGHT (m)	TABLE ANGLE (Degree)	RAW VALUE (dBuV)	CORRECTION FACTOR (dB/m)
1	5150.00	56.2 PK	74.0	-17.8	1.72 V	318	52.5	3.7
2	5150.00	44.1 AV	54.0	-9.9	1.72 V	318	40.4	3.7
3	*5260.00	115.8 PK			1.60 V	352	76.4	39.4
4	*5260.00	105.1 AV			1.60 V	352	65.7	39.4
5	#10520.00	59.3 PK	74.0	-14.7	2.13 V	269	42.5	16.8
6	#10520.00	45.5 AV	54.0	-8.5	2.13 V	269	28.7	16.8

Remarks:

1. Emission Level(dBuV/m) = Raw Value(dBuV) + Correction Factor(dB/m)
2. Correction Factor(dB/m) = Antenna Factor(dB/m) + Cable Factor(dB) – Pre-Amplifier Factor(dB)
3. The other emission levels were very low against the limit.
4. Margin value = Emission Level – Limit value
5. " * ": Fundamental frequency.
6. " # ": The radiated frequency is out of the restricted band.

CHANNEL	TX Channel 60	DETECTOR	Peak (PK)
FREQUENCY RANGE	1GHz ~ 40GHz	FUNCTION	Average (AV)

ANTENNA POLARITY & TEST DISTANCE: HORIZONTAL AT 3 M

NO.	FREQ. (MHz)	EMISSION LEVEL (dBuV/m)	LIMIT (dBuV/m)	MARGIN (dB)	ANTENNA HEIGHT (m)	TABLE ANGLE (Degree)	RAW VALUE (dBuV)	CORRECTION FACTOR (dB/m)
1	*5300.00	118.8 PK			1.92 H	355	79.4	39.4
2	*5300.00	108.8 AV			1.92 H	355	69.4	39.4
3	10600.00	58.8 PK	74.0	-15.2	2.31 H	188	41.9	16.9
4	10600.00	45.7 AV	54.0	-8.3	2.31 H	188	28.8	16.9

ANTENNA POLARITY & TEST DISTANCE: VERTICAL AT 3 M

NO.	FREQ. (MHz)	EMISSION LEVEL (dBuV/m)	LIMIT (dBuV/m)	MARGIN (dB)	ANTENNA HEIGHT (m)	TABLE ANGLE (Degree)	RAW VALUE (dBuV)	CORRECTION FACTOR (dB/m)
1	*5300.00	116.4 PK			1.23 V	348	77.0	39.4
2	*5300.00	105.7 AV			1.23 V	348	66.3	39.4
3	10600.00	58.5 PK	74.0	-15.5	2.03 V	186	41.6	16.9
4	10600.00	45.5 AV	54.0	-8.5	2.03 V	186	28.6	16.9

Remarks:

1. Emission Level(dBuV/m) = Raw Value(dBuV) + Correction Factor(dB/m)
2. Correction Factor(dB/m) = Antenna Factor(dB/m) + Cable Factor(dB) – Pre-Amplifier Factor(dB)
3. The other emission levels were very low against the limit.
4. Margin value = Emission Level – Limit value
5. " * ": Fundamental frequency.
6. " # ": The radiated frequency is out of the restricted band.

CHANNEL	TX Channel 64	DETECTOR FUNCTION	Peak (PK)
FREQUENCY RANGE	1GHz ~ 40GHz		Average (AV)

ANTENNA POLARITY & TEST DISTANCE: HORIZONTAL AT 3 M								
NO.	FREQ. (MHz)	EMISSION LEVEL (dBuV/m)	LIMIT (dBuV/m)	MARGIN (dB)	ANTENNA HEIGHT (m)	TABLE ANGLE (Degree)	RAW VALUE (dBuV)	CORRECTION FACTOR (dB/m)
1	*5320.00	119.4 PK			1.75 H	1	79.9	39.5
2	*5320.00	109.0 AV			1.75 H	1	69.5	39.5
3	5350.00	68.4 PK	74.0	-5.6	1.65 H	4	64.6	3.8
4	5350.00	52.6 AV	54.0	-1.4	1.65 H	4	48.8	3.8
5	10640.00	58.7 PK	74.0	-15.3	1.99 H	206	41.7	17.0
6	10640.00	44.9 AV	54.0	-9.1	1.99 H	206	27.9	17.0
ANTENNA POLARITY & TEST DISTANCE: VERTICAL AT 3 M								
NO.	FREQ. (MHz)	EMISSION LEVEL (dBuV/m)	LIMIT (dBuV/m)	MARGIN (dB)	ANTENNA HEIGHT (m)	TABLE ANGLE (Degree)	RAW VALUE (dBuV)	CORRECTION FACTOR (dB/m)
1	*5320.00	117.0 PK			3.32 V	347	77.5	39.5
2	*5320.00	106.2 AV			3.32 V	347	66.7	39.5
3	5350.00	64.5 PK	74.0	-9.5	3.18 V	338	60.7	3.8
4	5350.00	49.5 AV	54.0	-4.5	3.18 V	338	45.7	3.8
5	10640.00	58.5 PK	74.0	-15.5	2.81 V	167	41.5	17.0
6	10640.00	44.9 AV	54.0	-9.1	2.81 V	167	27.9	17.0

Remarks:

1. Emission Level(dBuV/m) = Raw Value(dBuV) + Correction Factor(dB/m)
2. Correction Factor(dB/m) = Antenna Factor(dB/m) + Cable Factor(dB) – Pre-Amplifier Factor(dB)
3. The other emission levels were very low against the limit.
4. Margin value = Emission Level – Limit value
5. " * ": Fundamental frequency.
6. " # ": The radiated frequency is out of the restricted band.

CHANNEL	TX Channel 100	DETECTOR FUNCTION	Peak (PK)
FREQUENCY RANGE	1GHz ~ 40GHz		Average (AV)

ANTENNA POLARITY & TEST DISTANCE: HORIZONTAL AT 3 M

NO.	FREQ. (MHz)	EMISSION LEVEL (dBuV/m)	LIMIT (dBuV/m)	MARGIN (dB)	ANTENNA HEIGHT (m)	TABLE ANGLE (Degree)	RAW VALUE (dBuV)	CORRECTION FACTOR (dB/m)
1	5460.00	62.7 PK	74.0	-11.3	1.38 H	342	58.5	4.2
2	5460.00	47.8 AV	54.0	-6.2	1.38 H	342	43.6	4.2
3	#5470.00	66.7 PK	74.0	-7.3	1.51 H	359	62.5	4.2
4	#5470.00	52.1 AV	54.0	-1.9	1.51 H	359	47.9	4.2
5	*5500.00	118.2 PK			1.49 H	1	78.1	40.1
6	*5500.00	107.5 AV			1.49 H	1	67.4	40.1
7	11000.00	60.5 PK	74.0	-13.5	1.69 H	287	41.8	18.7
8	11000.00	47.0 AV	54.0	-7.0	1.69 H	287	28.3	18.7

ANTENNA POLARITY & TEST DISTANCE: VERTICAL AT 3 M

NO.	FREQ. (MHz)	EMISSION LEVEL (dBuV/m)	LIMIT (dBuV/m)	MARGIN (dB)	ANTENNA HEIGHT (m)	TABLE ANGLE (Degree)	RAW VALUE (dBuV)	CORRECTION FACTOR (dB/m)
1	5460.00	58.2 PK	74.0	-15.8	2.89 V	341	54.0	4.2
2	5460.00	45.8 AV	54.0	-8.2	2.89 V	341	41.6	4.2
3	#5470.00	63.1 PK	74.0	-10.9	3.05 V	325	58.9	4.2
4	#5470.00	49.2 AV	54.0	-4.8	3.05 V	325	45.0	4.2
5	*5500.00	116.7 PK			2.90 V	331	76.6	40.1
6	*5500.00	105.8 AV			2.90 V	331	65.7	40.1
7	11000.00	60.9 PK	74.0	-13.1	1.83 V	234	42.2	18.7
8	11000.00	47.2 AV	54.0	-6.8	1.83 V	234	28.5	18.7

Remarks:

1. Emission Level(dBuV/m) = Raw Value(dBuV) + Correction Factor(dB/m)
2. Correction Factor(dB/m) = Antenna Factor(dB/m) + Cable Factor(dB) – Pre-Amplifier Factor(dB)
3. The other emission levels were very low against the limit.
4. Margin value = Emission Level – Limit value
5. " * ": Fundamental frequency.
6. " # ": The radiated frequency is out of the restricted band.

CHANNEL	TX Channel 116	DETECTOR FUNCTION	Peak (PK)
FREQUENCY RANGE	1GHz ~ 40GHz		Average (AV)

ANTENNA POLARITY & TEST DISTANCE: HORIZONTAL AT 3 M								
NO.	FREQ. (MHz)	EMISSION LEVEL (dBuV/m)	LIMIT (dBuV/m)	MARGIN (dB)	ANTENNA HEIGHT (m)	TABLE ANGLE (Degree)	RAW VALUE (dBuV)	CORRECTION FACTOR (dB/m)
1	*5580.00	118.4 PK			1.67 H	332	78.4	40.0
2	*5580.00	107.4 AV			1.67 H	332	67.4	40.0
3	11160.00	60.0 PK	74.0	-14.0	1.89 H	231	42.3	17.7
4	11160.00	46.1 AV	54.0	-7.9	1.89 H	231	28.4	17.7
ANTENNA POLARITY & TEST DISTANCE: VERTICAL AT 3 M								
NO.	FREQ. (MHz)	EMISSION LEVEL (dBuV/m)	LIMIT (dBuV/m)	MARGIN (dB)	ANTENNA HEIGHT (m)	TABLE ANGLE (Degree)	RAW VALUE (dBuV)	CORRECTION FACTOR (dB/m)
1	*5580.00	116.4 PK			2.81 V	338	76.4	40.0
2	*5580.00	105.3 AV			2.81 V	338	65.3	40.0
3	11160.00	60.9 PK	74.0	-13.1	2.83 V	156	43.2	17.7
4	11160.00	46.3 AV	54.0	-7.7	2.83 V	156	28.6	17.7

Remarks:

1. Emission Level(dBuV/m) = Raw Value(dBuV) + Correction Factor(dB/m)
2. Correction Factor(dB/m) = Antenna Factor(dB/m) + Cable Factor(dB) – Pre-Amplifier Factor(dB)
3. The other emission levels were very low against the limit.
4. Margin value = Emission Level – Limit value
5. " * ": Fundamental frequency.
6. " # ": The radiated frequency is out of the restricted band.

CHANNEL	TX Channel 140	DETECTOR FUNCTION	Peak (PK)
FREQUENCY RANGE	1GHz ~ 40GHz		Average (AV)

ANTENNA POLARITY & TEST DISTANCE: HORIZONTAL AT 3 M

NO.	FREQ. (MHz)	EMISSION LEVEL (dBuV/m)	LIMIT (dBuV/m)	MARGIN (dB)	ANTENNA HEIGHT (m)	TABLE ANGLE (Degree)	RAW VALUE (dBuV)	CORRECTION FACTOR (dB/m)
1	*5700.00	116.6 PK			1.22 H	334	76.6	40.0
2	*5700.00	105.3 AV			1.22 H	334	65.3	40.0
3	#5725.00	69.1 PK	74.0	-4.9	1.25 H	7	65.0	4.1
4	#5725.00	52.3 AV	54.0	-1.7	1.25 H	7	48.2	4.1
5	11400.00	60.2 PK	74.0	-13.8	1.63 H	296	42.5	17.7
6	11400.00	47.1 AV	54.0	-6.9	1.63 H	296	29.4	17.7

ANTENNA POLARITY & TEST DISTANCE: VERTICAL AT 3 M

NO.	FREQ. (MHz)	EMISSION LEVEL (dBuV/m)	LIMIT (dBuV/m)	MARGIN (dB)	ANTENNA HEIGHT (m)	TABLE ANGLE (Degree)	RAW VALUE (dBuV)	CORRECTION FACTOR (dB/m)
1	*5700.00	115.0 PK			2.83 V	333	75.0	40.0
2	*5700.00	104.0 AV			2.83 V	333	64.0	40.0
3	#5725.00	67.6 PK	74.0	-6.4	2.93 V	333	63.5	4.1
4	#5725.00	50.5 AV	54.0	-3.5	2.93 V	333	46.4	4.1
5	11400.00	60.0 PK	74.0	-14.0	2.23 V	238	42.3	17.7
6	11400.00	47.2 AV	54.0	-6.8	2.23 V	238	29.5	17.7

Remarks:

1. Emission Level(dBuV/m) = Raw Value(dBuV) + Correction Factor(dB/m)
2. Correction Factor(dB/m) = Antenna Factor(dB/m) + Cable Factor(dB) – Pre-Amplifier Factor(dB)
3. The other emission levels were very low against the limit.
4. Margin value = Emission Level – Limit value
5. " * ": Fundamental frequency.
6. " # ": The radiated frequency is out of the restricted band.

CHANNEL	TX Channel 144	DETECTOR FUNCTION	Peak (PK)
FREQUENCY RANGE	1GHz ~ 40GHz		Average (AV)

ANTENNA POLARITY & TEST DISTANCE: HORIZONTAL AT 3 M

NO.	FREQ. (MHz)	EMISSION LEVEL (dBuV/m)	LIMIT (dBuV/m)	MARGIN (dB)	ANTENNA HEIGHT (m)	TABLE ANGLE (Degree)	RAW VALUE (dBuV)	CORRECTION FACTOR (dB/m)
1	#5470.00	56.8 PK	74.0	-17.2	1.12 H	21	52.6	4.2
2	#5470.00	43.1 AV	54.0	-10.9	1.12 H	21	38.9	4.2
3	*5720.00	117.5 PK			1.04 H	11	77.5	40.0
4	*5720.00	106.9 AV			1.04 H	11	66.9	40.0
5	#5825.00	57.9 PK	74.0	-16.1	1.22 H	17	53.3	4.6
6	#5825.00	44.2 AV	54.0	-9.8	1.22 H	17	39.6	4.6
7	11440.00	60.7 PK	74.0	-13.3	1.89 H	264	42.8	17.9
8	11440.00	47.5 AV	54.0	-6.5	1.89 H	264	29.6	17.9

ANTENNA POLARITY & TEST DISTANCE: VERTICAL AT 3 M

NO.	FREQ. (MHz)	EMISSION LEVEL (dBuV/m)	LIMIT (dBuV/m)	MARGIN (dB)	ANTENNA HEIGHT (m)	TABLE ANGLE (Degree)	RAW VALUE (dBuV)	CORRECTION FACTOR (dB/m)
1	#5470.00	56.2 PK	74.0	-17.8	2.19 V	348	52.0	4.2
2	#5470.00	43.3 AV	54.0	-10.7	2.19 V	348	39.1	4.2
3	*5720.00	116.6 PK			2.30 V	19	76.6	40.0
4	*5720.00	105.2 AV			2.30 V	19	65.2	40.0
5	#5825.00	58.0 PK	74.0	-16.0	2.05 V	339	53.4	4.6
6	#5825.00	44.1 AV	54.0	-9.9	2.05 V	339	39.5	4.6
7	11440.00	61.4 PK	74.0	-12.6	2.64 V	188	43.5	17.9
8	11440.00	48.1 AV	54.0	-5.9	2.64 V	188	30.2	17.9

REMARKS:

1. Emission Level(dBuV/m) = Raw Value(dBuV) + Correction Factor(dB/m)
2. Correction Factor(dB/m) = Antenna Factor(dB/m) + Cable Factor(dB) – Pre-Amplifier Factor(dB)
3. The other emission levels were very low against the limit.
4. Margin value = Emission Level – Limit value
5. " * ": Fundamental frequency.
6. " # ": The radiated frequency is out of the restricted band.

802.11n (HT20)

CHANNEL	TX Channel 52	DETECTOR FUNCTION	Peak (PK)
FREQUENCY RANGE	1GHz ~ 40GHz		Average (AV)

ANTENNA POLARITY & TEST DISTANCE: HORIZONTAL AT 3 M								
NO.	FREQ. (MHz)	EMISSION LEVEL (dBuV/m)	LIMIT (dBuV/m)	MARGIN (dB)	ANTENNA HEIGHT (m)	TABLE ANGLE (Degree)	RAW VALUE (dBuV)	CORRECTION FACTOR (dB/m)
1	5150.00	56.8 PK	74.0	-17.2	1.67 H	345	53.1	3.7
2	5150.00	45.2 AV	54.0	-8.8	1.67 H	345	41.5	3.7
3	*5260.00	119.5 PK			1.88 H	360	80.1	39.4
4	*5260.00	108.5 AV			1.88 H	360	69.1	39.4
5	#10520.00	59.1 PK	74.0	-14.9	2.43 H	196	42.3	16.8
6	#10520.00	45.1 AV	54.0	-8.9	2.43 H	196	28.3	16.8

ANTENNA POLARITY & TEST DISTANCE: VERTICAL AT 3 M								
NO.	FREQ. (MHz)	EMISSION LEVEL (dBuV/m)	LIMIT (dBuV/m)	MARGIN (dB)	ANTENNA HEIGHT (m)	TABLE ANGLE (Degree)	RAW VALUE (dBuV)	CORRECTION FACTOR (dB/m)
1	5150.00	55.7 PK	74.0	-18.3	1.62 V	339	52.0	3.7
2	5150.00	43.7 AV	54.0	-10.3	1.62 V	339	40.0	3.7
3	*5260.00	116.5 PK			1.56 V	342	77.1	39.4
4	*5260.00	105.5 AV			1.56 V	342	66.1	39.4
5	#10520.00	58.8 PK	74.0	-15.2	2.38 V	261	42.0	16.8
6	#10520.00	45.4 AV	54.0	-8.6	2.38 V	261	28.6	16.8

Remarks:

1. Emission Level(dBuV/m) = Raw Value(dBuV) + Correction Factor(dB/m)
2. Correction Factor(dB/m) = Antenna Factor(dB/m) + Cable Factor(dB) – Pre-Amplifier Factor(dB)
3. The other emission levels were very low against the limit.
4. Margin value = Emission Level – Limit value
5. " * ": Fundamental frequency.
6. " # ": The radiated frequency is out of the restricted band.

CHANNEL	TX Channel 60	DETECTOR	Peak (PK)
FREQUENCY RANGE	1GHz ~ 40GHz	FUNCTION	Average (AV)

ANTENNA POLARITY & TEST DISTANCE: HORIZONTAL AT 3 M

NO.	FREQ. (MHz)	EMISSION LEVEL (dBuV/m)	LIMIT (dBuV/m)	MARGIN (dB)	ANTENNA HEIGHT (m)	TABLE ANGLE (Degree)	RAW VALUE (dBuV)	CORRECTION FACTOR (dB/m)
1	*5300.00	118.9 PK			1.84 H	2	79.5	39.4
2	*5300.00	108.2 AV			1.84 H	2	68.8	39.4
3	10600.00	58.6 PK	74.0	-15.4	1.88 H	236	41.7	16.9
4	10600.00	45.5 AV	54.0	-8.5	1.88 H	236	28.6	16.9

ANTENNA POLARITY & TEST DISTANCE: VERTICAL AT 3 M

NO.	FREQ. (MHz)	EMISSION LEVEL (dBuV/m)	LIMIT (dBuV/m)	MARGIN (dB)	ANTENNA HEIGHT (m)	TABLE ANGLE (Degree)	RAW VALUE (dBuV)	CORRECTION FACTOR (dB/m)
1	*5300.00	116.3 PK			1.40 V	342	76.9	39.4
2	*5300.00	105.0 AV			1.40 V	342	65.6	39.4
3	10600.00	59.4 PK	74.0	-14.6	2.23 V	284	42.5	16.9
4	10600.00	45.5 AV	54.0	-8.5	2.23 V	284	28.6	16.9

Remarks:

1. Emission Level(dBuV/m) = Raw Value(dBuV) + Correction Factor(dB/m)
2. Correction Factor(dB/m) = Antenna Factor(dB/m) + Cable Factor(dB) – Pre-Amplifier Factor(dB)
3. The other emission levels were very low against the limit.
4. Margin value = Emission Level – Limit value
5. " * ": Fundamental frequency.
6. " # ": The radiated frequency is out of the restricted band.

CHANNEL	TX Channel 64	DETECTOR FUNCTION	Peak (PK)
FREQUENCY RANGE	1GHz ~ 40GHz		Average (AV)

ANTENNA POLARITY & TEST DISTANCE: HORIZONTAL AT 3 M								
NO.	FREQ. (MHz)	EMISSION LEVEL (dBuV/m)	LIMIT (dBuV/m)	MARGIN (dB)	ANTENNA HEIGHT (m)	TABLE ANGLE (Degree)	RAW VALUE (dBuV)	CORRECTION FACTOR (dB/m)
1	*5320.00	119.7 PK			1.80 H	359	80.2	39.5
2	*5320.00	108.6 AV			1.80 H	359	69.1	39.5
3	5350.00	68.4 PK	74.0	-5.6	1.88 H	342	64.6	3.8
4	5350.00	52.1 AV	54.0	-1.9	1.88 H	342	48.3	3.8
5	10640.00	59.6 PK	74.0	-14.4	1.89 H	236	42.6	17.0
6	10640.00	46.4 AV	54.0	-7.6	1.89 H	236	29.4	17.0

ANTENNA POLARITY & TEST DISTANCE: VERTICAL AT 3 M								
NO.	FREQ. (MHz)	EMISSION LEVEL (dBuV/m)	LIMIT (dBuV/m)	MARGIN (dB)	ANTENNA HEIGHT (m)	TABLE ANGLE (Degree)	RAW VALUE (dBuV)	CORRECTION FACTOR (dB/m)
1	*5320.00	117.4 PK			3.20 V	336	77.9	39.5
2	*5320.00	106.1 AV			3.20 V	336	66.6	39.5
3	5350.00	66.3 PK	74.0	-7.7	1.43 V	359	62.5	3.8
4	5350.00	49.5 AV	54.0	-4.5	1.43 V	359	45.7	3.8
5	10640.00	58.5 PK	74.0	-15.5	2.23 V	264	41.5	17.0
6	10640.00	45.3 AV	54.0	-8.7	2.23 V	264	28.3	17.0

Remarks:

1. Emission Level(dBuV/m) = Raw Value(dBuV) + Correction Factor(dB/m)
2. Correction Factor(dB/m) = Antenna Factor(dB/m) + Cable Factor(dB) – Pre-Amplifier Factor(dB)
3. The other emission levels were very low against the limit.
4. Margin value = Emission Level – Limit value
5. " * ": Fundamental frequency.
6. " # ": The radiated frequency is out of the restricted band.

CHANNEL	TX Channel 100	DETECTOR FUNCTION	Peak (PK)
FREQUENCY RANGE	1GHz ~ 40GHz		Average (AV)

ANTENNA POLARITY & TEST DISTANCE: HORIZONTAL AT 3 M

NO.	FREQ. (MHz)	EMISSION LEVEL (dBuV/m)	LIMIT (dBuV/m)	MARGIN (dB)	ANTENNA HEIGHT (m)	TABLE ANGLE (Degree)	RAW VALUE (dBuV)	CORRECTION FACTOR (dB/m)
1	5460.00	61.6 PK	74.0	-12.4	1.56 H	359	57.4	4.2
2	5460.00	47.8 AV	54.0	-6.2	1.56 H	359	43.6	4.2
3	#5470.00	66.2 PK	74.0	-7.8	1.50 H	336	62.0	4.2
4	#5470.00	52.2 AV	54.0	-1.8	1.50 H	336	48.0	4.2
5	*5500.00	118.8 PK			1.48 H	359	78.7	40.1
6	*5500.00	107.8 AV			1.48 H	359	67.7	40.1
7	11000.00	60.4 PK	74.0	-13.6	1.68 H	264	41.7	18.7
8	11000.00	47.1 AV	54.0	-6.9	1.68 H	264	28.4	18.7

ANTENNA POLARITY & TEST DISTANCE: VERTICAL AT 3 M

NO.	FREQ. (MHz)	EMISSION LEVEL (dBuV/m)	LIMIT (dBuV/m)	MARGIN (dB)	ANTENNA HEIGHT (m)	TABLE ANGLE (Degree)	RAW VALUE (dBuV)	CORRECTION FACTOR (dB/m)
1	5460.00	57.3 PK	74.0	-16.7	2.73 V	355	53.1	4.2
2	5460.00	44.4 AV	54.0	-9.6	2.73 V	355	40.2	4.2
3	#5470.00	64.4 PK	74.0	-9.6	2.90 V	348	60.2	4.2
4	#5470.00	50.3 AV	54.0	-3.7	2.90 V	348	46.1	4.2
5	*5500.00	117.3 PK			2.89 V	337	77.2	40.1
6	*5500.00	105.9 AV			2.89 V	337	65.8	40.1
7	11000.00	60.8 PK	74.0	-13.2	2.34 V	183	42.1	18.7
8	11000.00	47.2 AV	54.0	-6.8	2.34 V	183	28.5	18.7

Remarks:

1. Emission Level(dBuV/m) = Raw Value(dBuV) + Correction Factor(dB/m)
2. Correction Factor(dB/m) = Antenna Factor(dB/m) + Cable Factor(dB) – Pre-Amplifier Factor(dB)
3. The other emission levels were very low against the limit.
4. Margin value = Emission Level – Limit value
5. " * ": Fundamental frequency.
6. " # ": The radiated frequency is out of the restricted band.

CHANNEL	TX Channel 116	DETECTOR FUNCTION	Peak (PK)
FREQUENCY RANGE	1GHz ~ 40GHz		Average (AV)

ANTENNA POLARITY & TEST DISTANCE: HORIZONTAL AT 3 M

NO.	FREQ. (MHz)	EMISSION LEVEL (dBuV/m)	LIMIT (dBuV/m)	MARGIN (dB)	ANTENNA HEIGHT (m)	TABLE ANGLE (Degree)	RAW VALUE (dBuV)	CORRECTION FACTOR (dB/m)
1	*5580.00	118.3 PK			1.43 H	6	78.3	40.0
2	*5580.00	107.4 AV			1.43 H	6	67.4	40.0
3	11160.00	59.7 PK	74.0	-14.3	1.99 H	201	42.0	17.7
4	11160.00	46.2 AV	54.0	-7.8	1.99 H	201	28.5	17.7

ANTENNA POLARITY & TEST DISTANCE: VERTICAL AT 3 M

NO.	FREQ. (MHz)	EMISSION LEVEL (dBuV/m)	LIMIT (dBuV/m)	MARGIN (dB)	ANTENNA HEIGHT (m)	TABLE ANGLE (Degree)	RAW VALUE (dBuV)	CORRECTION FACTOR (dB/m)
1	*5580.00	113.9 PK			2.37 V	7	73.9	40.0
2	*5580.00	102.8 AV			2.37 V	7	62.8	40.0
3	11160.00	60.2 PK	74.0	-13.8	2.31 V	188	42.5	17.7
4	11160.00	46.5 AV	54.0	-7.5	2.31 V	188	28.8	17.7

Remarks:

1. Emission Level(dBuV/m) = Raw Value(dBuV) + Correction Factor(dB/m)
2. Correction Factor(dB/m) = Antenna Factor(dB/m) + Cable Factor(dB) – Pre-Amplifier Factor(dB)
3. The other emission levels were very low against the limit.
4. Margin value = Emission Level – Limit value
5. " * ": Fundamental frequency.
6. " # ": The radiated frequency is out of the restricted band.

CHANNEL	TX Channel 140	DETECTOR FUNCTION	Peak (PK)
FREQUENCY RANGE	1GHz ~ 40GHz		Average (AV)

ANTENNA POLARITY & TEST DISTANCE: HORIZONTAL AT 3 M								
NO.	FREQ. (MHz)	EMISSION LEVEL (dBuV/m)	LIMIT (dBuV/m)	MARGIN (dB)	ANTENNA HEIGHT (m)	TABLE ANGLE (Degree)	RAW VALUE (dBuV)	CORRECTION FACTOR (dB/m)
1	*5700.00	116.8 PK			1.30 H	8	76.8	40.0
2	*5700.00	105.4 AV			1.30 H	8	65.4	40.0
3	#5725.00	69.8 PK	74.0	-4.2	1.30 H	11	65.7	4.1
4	#5725.00	52.1 AV	54.0	-1.9	1.30 H	11	48.0	4.1
5	11400.00	60.6 PK	74.0	-13.4	1.83 H	269	42.9	17.7
6	11400.00	47.3 AV	54.0	-6.7	1.83 H	269	29.6	17.7
ANTENNA POLARITY & TEST DISTANCE: VERTICAL AT 3 M								
NO.	FREQ. (MHz)	EMISSION LEVEL (dBuV/m)	LIMIT (dBuV/m)	MARGIN (dB)	ANTENNA HEIGHT (m)	TABLE ANGLE (Degree)	RAW VALUE (dBuV)	CORRECTION FACTOR (dB/m)
1	*5700.00	115.1 PK			2.02 V	23	75.1	40.0
2	*5700.00	103.7 AV			2.02 V	23	63.7	40.0
3	#5725.00	67.4 PK	74.0	-6.6	2.03 V	20	63.3	4.1
4	#5725.00	50.1 AV	54.0	-3.9	2.03 V	20	46.0	4.1
5	11400.00	61.0 PK	74.0	-13.0	2.68 V	231	43.3	17.7
6	11400.00	47.2 AV	54.0	-6.8	2.68 V	231	29.5	17.7

Remarks:

1. Emission Level(dBuV/m) = Raw Value(dBuV) + Correction Factor(dB/m)
2. Correction Factor(dB/m) = Antenna Factor(dB/m) + Cable Factor(dB) – Pre-Amplifier Factor(dB)
3. The other emission levels were very low against the limit.
4. Margin value = Emission Level – Limit value
5. " * ": Fundamental frequency.
6. " # ": The radiated frequency is out of the restricted band.

CHANNEL	TX Channel 144	DETECTOR FUNCTION	Peak (PK)
FREQUENCY RANGE	1GHz ~ 40GHz		Average (AV)

ANTENNA POLARITY & TEST DISTANCE: HORIZONTAL AT 3 M								
NO.	FREQ. (MHz)	EMISSION LEVEL (dBuV/m)	LIMIT (dBuV/m)	MARGIN (dB)	ANTENNA HEIGHT (m)	TABLE ANGLE (Degree)	RAW VALUE (dBuV)	CORRECTION FACTOR (dB/m)
1	#5470.00	56.6 PK	74.0	-17.4	1.46 H	328	52.4	4.2
2	#5470.00	43.1 AV	54.0	-10.9	1.46 H	328	38.9	4.2
3	*5720.00	118.9 PK			1.10 H	11	78.9	40.0
4	*5720.00	107.3 AV			1.10 H	11	67.3	40.0
5	#5825.00	57.2 PK	74.0	-16.8	1.34 H	358	52.6	4.6
6	#5825.00	43.8 AV	54.0	-10.2	1.34 H	358	39.2	4.6
7	11440.00	61.3 PK	74.0	-12.7	2.83 H	134	43.4	17.9
8	11440.00	47.8 AV	54.0	-6.2	2.83 H	134	29.9	17.9

ANTENNA POLARITY & TEST DISTANCE: VERTICAL AT 3 M								
NO.	FREQ. (MHz)	EMISSION LEVEL (dBuV/m)	LIMIT (dBuV/m)	MARGIN (dB)	ANTENNA HEIGHT (m)	TABLE ANGLE (Degree)	RAW VALUE (dBuV)	CORRECTION FACTOR (dB/m)
1	#5470.00	57.1 PK	74.0	-16.9	1.99 V	323	52.9	4.2
2	#5470.00	43.4 AV	54.0	-10.6	1.99 V	323	39.2	4.2
3	*5720.00	116.3 PK			2.03 V	19	76.3	40.0
4	*5720.00	105.2 AV			2.03 V	19	65.2	40.0
5	#5825.00	58.0 PK	74.0	-16.0	1.89 V	338	53.4	4.6
6	#5825.00	44.2 AV	54.0	-9.8	1.89 V	338	39.6	4.6
7	11440.00	61.5 PK	74.0	-12.5	2.55 V	181	43.6	17.9
8	11440.00	47.8 AV	54.0	-6.2	2.55 V	181	29.9	17.9

REMARKS:

1. Emission Level(dBuV/m) = Raw Value(dBuV) + Correction Factor(dB/m)
2. Correction Factor(dB/m) = Antenna Factor(dB/m) + Cable Factor(dB) – Pre-Amplifier Factor(dB)
3. The other emission levels were very low against the limit.
4. Margin value = Emission Level – Limit value
5. " * " : Fundamental frequency.
6. " # " : The radiated frequency is out of the restricted band.

802.11n (HT40)

CHANNEL	TX Channel 54	DETECTOR FUNCTION	Peak (PK)
FREQUENCY RANGE	1GHz ~ 40GHz		Average (AV)

ANTENNA POLARITY & TEST DISTANCE: HORIZONTAL AT 3 M

NO.	FREQ. (MHz)	EMISSION LEVEL (dBuV/m)	LIMIT (dBuV/m)	MARGIN (dB)	ANTENNA HEIGHT (m)	TABLE ANGLE (Degree)	RAW VALUE (dBuV)	CORRECTION FACTOR (dB/m)
1	5150.00	46.4 PK	74.0	-27.6	1.89 H	355	42.7	3.7
2	5150.00	44.6 AV	54.0	-9.4	1.89 H	355	40.9	3.7
3	*5270.00	115.9 PK			1.86 H	2	76.5	39.4
4	*5270.00	105.7 AV			1.86 H	2	66.3	39.4
5	#10540.00	58.9 PK	74.0	-15.1	1.83 H	286	42.0	16.9
6	#10540.00	45.7 AV	54.0	-8.3	1.83 H	286	28.8	16.9

ANTENNA POLARITY & TEST DISTANCE: VERTICAL AT 3 M

NO.	FREQ. (MHz)	EMISSION LEVEL (dBuV/m)	LIMIT (dBuV/m)	MARGIN (dB)	ANTENNA HEIGHT (m)	TABLE ANGLE (Degree)	RAW VALUE (dBuV)	CORRECTION FACTOR (dB/m)
1	5150.00	55.9 PK	74.0	-18.1	1.62 V	334	52.2	3.7
2	5150.00	43.6 AV	54.0	-10.4	1.62 V	334	39.9	3.7
3	*5270.00	113.2 PK			1.54 V	342	73.8	39.4
4	*5270.00	103.0 AV			1.54 V	342	63.6	39.4
5	#10540.00	59.0 PK	74.0	-15.0	2.22 V	263	42.1	16.9
6	#10540.00	45.8 AV	54.0	-8.2	2.22 V	263	28.9	16.9

Remarks:

1. Emission Level(dBuV/m) = Raw Value(dBuV) + Correction Factor(dB/m)
2. Correction Factor(dB/m) = Antenna Factor(dB/m) + Cable Factor(dB) – Pre-Amplifier Factor(dB)
3. The other emission levels were very low against the limit.
4. Margin value = Emission Level – Limit value
5. " * ": Fundamental frequency.
6. " # ": The radiated frequency is out of the restricted band.

CHANNEL	TX Channel 62	DETECTOR FUNCTION	Peak (PK)
FREQUENCY RANGE	1GHz ~ 40GHz		Average (AV)

ANTENNA POLARITY & TEST DISTANCE: HORIZONTAL AT 3 M								
NO.	FREQ. (MHz)	EMISSION LEVEL (dBuV/m)	LIMIT (dBuV/m)	MARGIN (dB)	ANTENNA HEIGHT (m)	TABLE ANGLE (Degree)	RAW VALUE (dBuV)	CORRECTION FACTOR (dB/m)
1	*5310.00	113.1 PK			1.76 H	358	73.7	39.4
2	*5310.00	103.2 AV			1.76 H	358	63.8	39.4
3	5350.00	67.2 PK	74.0	-6.8	1.65 H	1	63.4	3.8
4	5350.00	52.5 AV	54.0	-1.5	1.65 H	1	48.7	3.8
5	10620.00	59.0 PK	74.0	-15.0	1.92 H	284	41.9	17.1
6	10620.00	45.4 AV	54.0	-8.6	1.92 H	284	28.3	17.1

ANTENNA POLARITY & TEST DISTANCE: VERTICAL AT 3 M								
NO.	FREQ. (MHz)	EMISSION LEVEL (dBuV/m)	LIMIT (dBuV/m)	MARGIN (dB)	ANTENNA HEIGHT (m)	TABLE ANGLE (Degree)	RAW VALUE (dBuV)	CORRECTION FACTOR (dB/m)
1	*5310.00	110.5 PK			1.52 V	341	71.1	39.4
2	*5310.00	100.1 AV			1.52 V	341	60.7	39.4
3	5350.00	63.0 PK	74.0	-11.0	1.50 V	337	59.2	3.8
4	5350.00	48.0 AV	54.0	-6.0	1.50 V	337	44.2	3.8
5	10620.00	58.8 PK	74.0	-15.2	2.18 V	183	41.7	17.1
6	10620.00	45.6 AV	54.0	-8.4	2.18 V	183	28.5	17.1

Remarks:

1. Emission Level(dBuV/m) = Raw Value(dBuV) + Correction Factor(dB/m)
2. Correction Factor(dB/m) = Antenna Factor(dB/m) + Cable Factor(dB) – Pre-Amplifier Factor(dB)
3. The other emission levels were very low against the limit.
4. Margin value = Emission Level – Limit value
5. " * ": Fundamental frequency.
6. " # ": The radiated frequency is out of the restricted band.

CHANNEL	TX Channel 102	DETECTOR FUNCTION	Peak (PK)
FREQUENCY RANGE	1GHz ~ 40GHz		Average (AV)

ANTENNA POLARITY & TEST DISTANCE: HORIZONTAL AT 3 M

NO.	FREQ. (MHz)	EMISSION LEVEL (dBuV/m)	LIMIT (dBuV/m)	MARGIN (dB)	ANTENNA HEIGHT (m)	TABLE ANGLE (Degree)	RAW VALUE (dBuV)	CORRECTION FACTOR (dB/m)
1	5460.00	59.8 PK	74.0	-14.2	1.67 H	323	55.6	4.2
2	5460.00	45.2 AV	54.0	-8.8	1.67 H	323	41.0	4.2
3	#5470.00	65.1 PK	74.0	-8.9	1.61 H	359	60.9	4.2
4	#5470.00	52.4 AV	54.0	-1.6	1.61 H	359	48.2	4.2
5	*5510.00	113.0 PK			1.36 H	7	72.9	40.1
6	*5510.00	102.6 AV			1.36 H	7	62.5	40.1
7	11020.00	60.4 PK	74.0	-13.6	1.69 H	231	41.9	18.5
8	11020.00	47.4 AV	54.0	-6.6	1.69 H	231	28.9	18.5

ANTENNA POLARITY & TEST DISTANCE: VERTICAL AT 3 M

NO.	FREQ. (MHz)	EMISSION LEVEL (dBuV/m)	LIMIT (dBuV/m)	MARGIN (dB)	ANTENNA HEIGHT (m)	TABLE ANGLE (Degree)	RAW VALUE (dBuV)	CORRECTION FACTOR (dB/m)
1	5460.00	58.1 PK	74.0	-15.9	2.77 V	331	53.9	4.2
2	5460.00	45.7 AV	54.0	-8.3	2.77 V	331	41.5	4.2
3	#5470.00	63.4 PK	74.0	-10.6	2.93 V	325	59.2	4.2
4	#5470.00	50.2 AV	54.0	-3.8	2.93 V	325	46.0	4.2
5	*5510.00	109.0 PK			2.52 V	351	68.9	40.1
6	*5510.00	98.4 AV			2.52 V	351	58.3	40.1
7	11020.00	60.7 PK	74.0	-13.3	1.88 V	261	42.2	18.5
8	11020.00	47.5 AV	54.0	-6.5	1.88 V	261	29.0	18.5

Remarks:

1. Emission Level(dBuV/m) = Raw Value(dBuV) + Correction Factor(dB/m)
2. Correction Factor(dB/m) = Antenna Factor(dB/m) + Cable Factor(dB) – Pre-Amplifier Factor(dB)
3. The other emission levels were very low against the limit.
4. Margin value = Emission Level – Limit value
5. " * ": Fundamental frequency.
6. " # ": The radiated frequency is out of the restricted band.

CHANNEL	TX Channel 110	DETECTOR	Peak (PK)
FREQUENCY RANGE	1GHz ~ 40GHz	FUNCTION	Average (AV)

ANTENNA POLARITY & TEST DISTANCE: HORIZONTAL AT 3 M

NO.	FREQ. (MHz)	EMISSION LEVEL (dBuV/m)	LIMIT (dBuV/m)	MARGIN (dB)	ANTENNA HEIGHT (m)	TABLE ANGLE (Degree)	RAW VALUE (dBuV)	CORRECTION FACTOR (dB/m)
1	*5550.00	115.3 PK			1.39 H	3	75.3	40.0
2	*5550.00	105.2 AV			1.39 H	3	65.2	40.0
3	11100.00	59.7 PK	74.0	-14.3	1.87 H	269	42.1	17.6
4	11100.00	46.5 AV	54.0	-7.5	1.87 H	269	28.9	17.6

ANTENNA POLARITY & TEST DISTANCE: VERTICAL AT 3 M

NO.	FREQ. (MHz)	EMISSION LEVEL (dBuV/m)	LIMIT (dBuV/m)	MARGIN (dB)	ANTENNA HEIGHT (m)	TABLE ANGLE (Degree)	RAW VALUE (dBuV)	CORRECTION FACTOR (dB/m)
1	*5550.00	111.4 PK			2.60 V	356	71.4	40.0
2	*5550.00	100.5 AV			2.60 V	356	60.5	40.0
3	11100.00	59.8 PK	74.0	-14.2	2.12 V	266	42.2	17.6
4	11100.00	46.5 AV	54.0	-7.5	2.12 V	266	28.9	17.6

Remarks:

1. Emission Level(dBuV/m) = Raw Value(dBuV) + Correction Factor(dB/m)
2. Correction Factor(dB/m) = Antenna Factor(dB/m) + Cable Factor(dB) – Pre-Amplifier Factor(dB)
3. The other emission levels were very low against the limit.
4. Margin value = Emission Level – Limit value
5. " * ": Fundamental frequency.
6. " # ": The radiated frequency is out of the restricted band.

CHANNEL	TX Channel 134	DETECTOR FUNCTION	Peak (PK)
FREQUENCY RANGE	1GHz ~ 40GHz		Average (AV)

ANTENNA POLARITY & TEST DISTANCE: HORIZONTAL AT 3 M								
NO.	FREQ. (MHz)	EMISSION LEVEL (dBuV/m)	LIMIT (dBuV/m)	MARGIN (dB)	ANTENNA HEIGHT (m)	TABLE ANGLE (Degree)	RAW VALUE (dBuV)	CORRECTION FACTOR (dB/m)
1	*5670.00	114.3 PK			1.61 H	330	74.2	40.1
2	*5670.00	103.8 AV			1.61 H	330	63.7	40.1
3	#5725.00	69.6 PK	74.0	-4.4	1.73 H	340	65.5	4.1
4	#5725.00	52.7 AV	54.0	-1.3	1.73 H	340	48.6	4.1
5	11340.00	60.3 PK	74.0	-13.7	1.96 H	234	42.4	17.9
6	11340.00	47.0 AV	54.0	-7.0	1.96 H	234	29.1	17.9

ANTENNA POLARITY & TEST DISTANCE: VERTICAL AT 3 M								
NO.	FREQ. (MHz)	EMISSION LEVEL (dBuV/m)	LIMIT (dBuV/m)	MARGIN (dB)	ANTENNA HEIGHT (m)	TABLE ANGLE (Degree)	RAW VALUE (dBuV)	CORRECTION FACTOR (dB/m)
1	*5670.00	112.4 PK			1.97 V	19	72.3	40.1
2	*5670.00	102.2 AV			1.97 V	19	62.1	40.1
3	#5725.00	68.1 PK	74.0	-5.9	2.12 V	16	64.0	4.1
4	#5725.00	51.6 AV	54.0	-2.4	2.12 V	16	47.5	4.1
5	11340.00	61.1 PK	74.0	-12.9	1.68 V	234	43.2	17.9
6	11340.00	47.3 AV	54.0	-6.7	1.68 V	234	29.4	17.9

Remarks:

1. Emission Level(dBuV/m) = Raw Value(dBuV) + Correction Factor(dB/m)
2. Correction Factor(dB/m) = Antenna Factor(dB/m) + Cable Factor(dB) – Pre-Amplifier Factor(dB)
3. The other emission levels were very low against the limit.
4. Margin value = Emission Level – Limit value
5. " * ": Fundamental frequency.
6. " # ": The radiated frequency is out of the restricted band.

CHANNEL	TX Channel 142	DETECTOR FUNCTION	Peak (PK)
FREQUENCY RANGE	1GHz ~ 40GHz		Average (AV)

ANTENNA POLARITY & TEST DISTANCE: HORIZONTAL AT 3 M

NO.	FREQ. (MHz)	EMISSION LEVEL (dBuV/m)	LIMIT (dBuV/m)	MARGIN (dB)	ANTENNA HEIGHT (m)	TABLE ANGLE (Degree)	RAW VALUE (dBuV)	CORRECTION FACTOR (dB/m)
1	#5470.00	56.5 PK	74.0	-17.5	1.42 H	359	52.3	4.2
2	#5470.00	43.6 AV	54.0	-10.4	1.42 H	359	39.4	4.2
3	*5710.00	114.9 PK			1.21 H	11	74.9	40.0
4	*5710.00	104.6 AV			1.21 H	11	64.6	40.0
5	#5825.00	57.7 PK	74.0	-16.3	1.34 H	8	53.1	4.6
6	#5825.00	44.2 AV	54.0	-9.8	1.34 H	8	39.6	4.6
7	11420.00	62.3 PK	74.0	-11.7	2.21 H	183	44.5	17.8
8	11420.00	47.7 AV	54.0	-6.3	2.21 H	183	29.9	17.8

ANTENNA POLARITY & TEST DISTANCE: VERTICAL AT 3 M

NO.	FREQ. (MHz)	EMISSION LEVEL (dBuV/m)	LIMIT (dBuV/m)	MARGIN (dB)	ANTENNA HEIGHT (m)	TABLE ANGLE (Degree)	RAW VALUE (dBuV)	CORRECTION FACTOR (dB/m)
1	#5470.00	56.6 PK	74.0	-17.4	1.99 V	12	52.4	4.2
2	#5470.00	43.1 AV	54.0	-10.9	1.99 V	12	38.9	4.2
3	*5710.00	113.3 PK			2.12 V	23	73.3	40.0
4	*5710.00	103.0 AV			2.12 V	23	63.0	40.0
5	#5825.00	58.0 PK	74.0	-16.0	1.98 V	20	53.4	4.6
6	#5825.00	44.2 AV	54.0	-9.8	1.98 V	20	39.6	4.6
7	11420.00	61.5 PK	74.0	-12.5	2.08 V	155	43.7	17.8
8	11420.00	47.8 AV	54.0	-6.2	2.08 V	155	30.0	17.8

REMARKS:

1. Emission Level(dBuV/m) = Raw Value(dBuV) + Correction Factor(dB/m)
2. Correction Factor(dB/m) = Antenna Factor(dB/m) + Cable Factor(dB) – Pre-Amplifier Factor(dB)
3. The other emission levels were very low against the limit.
4. Margin value = Emission Level – Limit value
5. " * " : Fundamental frequency.
6. " # " : The radiated frequency is out of the restricted band.

802.11ac (VHT80)

CHANNEL	TX Channel 58	DETECTOR FUNCTION	Peak (PK)
FREQUENCY RANGE	1GHz ~ 40GHz		Average (AV)

ANTENNA POLARITY & TEST DISTANCE: HORIZONTAL AT 3 M

NO.	FREQ. (MHz)	EMISSION LEVEL (dBuV/m)	LIMIT (dBuV/m)	MARGIN (dB)	ANTENNA HEIGHT (m)	TABLE ANGLE (Degree)	RAW VALUE (dBuV)	CORRECTION FACTOR (dB/m)
1	5150.00	57.1 PK	74.0	-16.9	1.79 H	358	53.4	3.7
2	5150.00	44.9 AV	54.0	-9.1	1.79 H	358	41.2	3.7
3	*5290.00	108.3 PK			1.83 H	1	68.9	39.4
4	*5290.00	98.2 AV			1.83 H	1	58.8	39.4
5	5350.00	65.3 PK	74.0	-8.7	1.59 H	3	61.5	3.8
6	5350.00	52.4 AV	54.0	-1.6	1.59 H	3	48.6	3.8
7	#10580.00	59.1 PK	74.0	-14.9	1.87 H	267	42.1	17.0
8	#10580.00	45.9 AV	54.0	-8.1	1.87 H	267	28.9	17.0

ANTENNA POLARITY & TEST DISTANCE: VERTICAL AT 3 M

NO.	FREQ. (MHz)	EMISSION LEVEL (dBuV/m)	LIMIT (dBuV/m)	MARGIN (dB)	ANTENNA HEIGHT (m)	TABLE ANGLE (Degree)	RAW VALUE (dBuV)	CORRECTION FACTOR (dB/m)
1	5150.00	56.7 PK	74.0	-17.3	1.21 V	341	53.0	3.7
2	5150.00	43.8 AV	54.0	-10.2	1.21 V	341	40.1	3.7
3	*5290.00	105.4 PK			1.19 V	349	66.0	39.4
4	*5290.00	95.4 AV			1.19 V	349	56.0	39.4
5	5350.00	62.8 PK	74.0	-11.2	1.19 V	340	59.0	3.8
6	5350.00	49.3 AV	54.0	-4.7	1.19 V	340	45.5	3.8
7	#10580.00	59.0 PK	74.0	-15.0	2.66 V	213	42.0	17.0
8	#10580.00	46.1 AV	54.0	-7.9	2.66 V	213	29.1	17.0

Remarks:

1. Emission Level(dBuV/m) = Raw Value(dBuV) + Correction Factor(dB/m)
2. Correction Factor(dB/m) = Antenna Factor(dB/m) + Cable Factor(dB) – Pre-Amplifier Factor(dB)
3. The other emission levels were very low against the limit.
4. Margin value = Emission Level – Limit value
5. " * ": Fundamental frequency.
6. " # ": The radiated frequency is out of the restricted band.

CHANNEL	TX Channel 106	DETECTOR FUNCTION	Peak (PK)
FREQUENCY RANGE	1GHz ~ 40GHz		Average (AV)

ANTENNA POLARITY & TEST DISTANCE: HORIZONTAL AT 3 M

NO.	FREQ. (MHz)	EMISSION LEVEL (dBuV/m)	LIMIT (dBuV/m)	MARGIN (dB)	ANTENNA HEIGHT (m)	TABLE ANGLE (Degree)	RAW VALUE (dBuV)	CORRECTION FACTOR (dB/m)
1	5460.00	60.4 PK	74.0	-13.6	1.76 H	343	56.2	4.2
2	5460.00	47.0 AV	54.0	-7.0	1.76 H	343	42.8	4.2
3	#5470.00	65.4 PK	74.0	-8.6	1.49 H	359	61.2	4.2
4	#5470.00	52.3 AV	54.0	-1.7	1.49 H	359	48.1	4.2
5	*5530.00	109.7 PK			1.52 H	337	69.6	40.1
6	*5530.00	99.5 AV			1.52 H	337	59.4	40.1
7	#5725.00	57.6 PK	74.0	-16.4	1.66 H	318	53.5	4.1
8	#5725.00	44.2 AV	54.0	-9.8	1.66 H	318	40.1	4.1
9	11060.00	60.3 PK	74.0	-13.7	1.88 H	236	42.3	18.0
10	11060.00	47.0 AV	54.0	-7.0	1.88 H	236	29.0	18.0

ANTENNA POLARITY & TEST DISTANCE: VERTICAL AT 3 M

NO.	FREQ. (MHz)	EMISSION LEVEL (dBuV/m)	LIMIT (dBuV/m)	MARGIN (dB)	ANTENNA HEIGHT (m)	TABLE ANGLE (Degree)	RAW VALUE (dBuV)	CORRECTION FACTOR (dB/m)
1	5460.00	60.0 PK	74.0	-14.0	2.56 V	313	55.8	4.2
2	5460.00	47.5 AV	54.0	-6.5	2.56 V	313	43.3	4.2
3	#5470.00	63.1 PK	74.0	-10.9	2.83 V	331	58.9	4.2
4	#5470.00	49.2 AV	54.0	-4.8	2.83 V	331	45.0	4.2
5	*5530.00	107.8 PK			2.84 V	338	67.7	40.1
6	*5530.00	97.4 AV			2.84 V	338	57.3	40.1
7	#5725.00	56.9 PK	74.0	-17.1	2.79 V	313	52.8	4.1
8	#5725.00	43.6 AV	54.0	-10.4	2.79 V	313	39.5	4.1
9	11060.00	60.6 PK	74.0	-13.4	2.44 V	213	42.6	18.0
10	11060.00	47.2 AV	54.0	-6.8	2.44 V	213	29.2	18.0

Remarks:

1. Emission Level(dBuV/m) = Raw Value(dBuV) + Correction Factor(dB/m)
2. Correction Factor(dB/m) = Antenna Factor(dB/m) + Cable Factor(dB) – Pre-Amplifier Factor(dB)
3. The other emission levels were very low against the limit.
4. Margin value = Emission Level – Limit value
5. " * ": Fundamental frequency.
6. " # ": The radiated frequency is out of the restricted band.

CHANNEL	TX Channel 138	DETECTOR FUNCTION	Peak (PK)
FREQUENCY RANGE	1GHz ~ 40GHz		Average (AV)

ANTENNA POLARITY & TEST DISTANCE: HORIZONTAL AT 3 M

NO.	FREQ. (MHz)	EMISSION LEVEL (dBuV/m)	LIMIT (dBuV/m)	MARGIN (dB)	ANTENNA HEIGHT (m)	TABLE ANGLE (Degree)	RAW VALUE (dBuV)	CORRECTION FACTOR (dB/m)
1	#5470.00	57.8 PK	74.0	-16.2	1.52 H	4	53.6	4.2
2	#5470.00	44.3 AV	54.0	-9.7	1.52 H	4	40.1	4.2
3	*5690.00	111.7 PK			1.07 H	11	71.7	40.0
4	*5690.00	101.2 AV			1.07 H	11	61.2	40.0
5	#5825.00	67.8 PK	74.0	-6.2	1.53 H	345	63.2	4.6
6	#5825.00	50.5 AV	54.0	-3.5	1.53 H	345	45.9	4.6
7	11380.00	61.6 PK	74.0	-12.4	2.31 H	188	43.8	17.8
8	11380.00	48.0 AV	54.0	-6.0	2.31 H	188	30.2	17.8

ANTENNA POLARITY & TEST DISTANCE: VERTICAL AT 3 M

NO.	FREQ. (MHz)	EMISSION LEVEL (dBuV/m)	LIMIT (dBuV/m)	MARGIN (dB)	ANTENNA HEIGHT (m)	TABLE ANGLE (Degree)	RAW VALUE (dBuV)	CORRECTION FACTOR (dB/m)
1	#5470.00	56.9 PK	74.0	-17.1	2.19 V	349	52.7	4.2
2	#5470.00	43.8 AV	54.0	-10.2	2.19 V	349	39.6	4.2
3	*5690.00	109.9 PK			2.31 V	19	69.9	40.0
4	*5690.00	99.0 AV			2.31 V	19	59.0	40.0
5	#5825.00	66.5 PK	74.0	-7.5	2.32 V	19	61.9	4.6
6	#5825.00	49.2 AV	54.0	-4.8	2.32 V	19	44.6	4.6
7	11380.00	62.0 PK	74.0	-12.0	2.44 V	198	44.2	17.8
8	11380.00	47.7 AV	54.0	-6.3	2.44 V	198	29.9	17.8

Remarks:

1. Emission Level(dBuV/m) = Raw Value(dBuV) + Correction Factor(dB/m)
2. Correction Factor(dB/m) = Antenna Factor(dB/m) + Cable Factor(dB) – Pre-Amplifier Factor(dB)
3. The other emission levels were very low against the limit.
4. Margin value = Emission Level – Limit value
5. " * ": Fundamental frequency.
6. " # ": The radiated frequency is out of the restricted band.

Below 1GHz worst-case data:

802.11a

CHANNEL	TX Channel 52	DETECTOR FUNCTION	Quasi-Peak (QP)
FREQUENCY RANGE	9kHz ~ 1GHz	TEST MODE	A

ANTENNA POLARITY & TEST DISTANCE: HORIZONTAL AT 3 M

NO.	FREQ. (MHz)	EMISSION LEVEL (dBuV/m)	LIMIT (dBuV/m)	MARGIN (dB)	ANTENNA HEIGHT (m)	TABLE ANGLE (Degree)	RAW VALUE (dBuV)	CORRECTION FACTOR (dB/m)
1	57.12	26.9 QP	40.0	-13.1	1.99 H	78	41.3	-14.4
2	162.11	26.8 QP	43.5	-16.7	1.00 H	87	40.7	-13.9
3	241.83	25.6 QP	46.0	-20.4	1.00 H	80	40.5	-14.9
4	282.66	28.9 QP	46.0	-17.1	1.00 H	91	42.0	-13.1
5	389.59	34.4 QP	46.0	-11.6	1.00 H	267	45.8	-11.4
6	484.86	25.5 QP	46.0	-20.5	1.99 H	199	35.1	-9.6

ANTENNA POLARITY & TEST DISTANCE: VERTICAL AT 3 M

NO.	FREQ. (MHz)	EMISSION LEVEL (dBuV/m)	LIMIT (dBuV/m)	MARGIN (dB)	ANTENNA HEIGHT (m)	TABLE ANGLE (Degree)	RAW VALUE (dBuV)	CORRECTION FACTOR (dB/m)
1	68.79	29.4 QP	40.0	-10.6	1.00 V	314	45.1	-15.7
2	148.50	22.6 QP	43.5	-20.9	1.00 V	268	36.4	-13.8
3	280.71	29.9 QP	46.0	-16.1	1.49 V	23	43.0	-13.1
4	333.21	29.0 QP	46.0	-17.0	1.00 V	193	41.1	-12.1
5	418.76	31.6 QP	46.0	-14.4	1.00 V	260	42.4	-10.8
6	716.23	27.3 QP	46.0	-18.7	1.49 V	23	33.0	-5.7

Remarks:

1. Emission Level(dBuV/m) = Raw Value(dBuV) + Correction Factor(dB/m)
2. Correction Factor(dB/m) = Antenna Factor(dB/m) + Cable Factor(dB) – Pre-Amplifier Factor(dB)
3. The other emission levels were very low against the limit.
4. Margin value = Emission Level – Limit value

CHANNEL	TX Channel 52	DETECTOR FUNCTION	Quasi-Peak (QP)
FREQUENCY RANGE	9kHz ~ 1GHz	TEST MODE	B

ANTENNA POLARITY & TEST DISTANCE: HORIZONTAL AT 3 M

NO.	FREQ. (MHz)	EMISSION LEVEL (dBuV/m)	LIMIT (dBuV/m)	MARGIN (dB)	ANTENNA HEIGHT (m)	TABLE ANGLE (Degree)	RAW VALUE (dBuV)	CORRECTION FACTOR (dB/m)
1	76.56	29.0 QP	40.0	-11.0	1.49 H	314	46.3	-17.3
2	162.11	30.7 QP	43.5	-12.8	1.49 H	94	44.6	-13.9
3	195.16	27.5 QP	43.5	-16.0	1.49 H	262	44.2	-16.7
4	280.71	24.9 QP	46.0	-21.1	1.00 H	155	38.0	-13.1
5	395.43	29.9 QP	46.0	-16.1	1.00 H	70	41.1	-11.2
6	650.13	25.3 QP	46.0	-20.7	1.00 H	170	31.9	-6.6

ANTENNA POLARITY & TEST DISTANCE: VERTICAL AT 3 M

NO.	FREQ. (MHz)	EMISSION LEVEL (dBuV/m)	LIMIT (dBuV/m)	MARGIN (dB)	ANTENNA HEIGHT (m)	TABLE ANGLE (Degree)	RAW VALUE (dBuV)	CORRECTION FACTOR (dB/m)
1	35.73	29.0 QP	40.0	-11.0	1.00 V	178	44.6	-15.6
2	57.12	28.1 QP	40.0	-11.9	1.00 V	353	42.5	-14.4
3	119.34	21.6 QP	43.5	-21.9	1.00 V	22	37.9	-16.3
4	280.71	24.0 QP	46.0	-22.0	1.00 V	192	37.1	-13.1
5	449.87	23.0 QP	46.0	-23.0	1.00 V	165	33.1	-10.1
6	525.69	23.8 QP	46.0	-22.2	1.00 V	268	32.9	-9.1

Remarks:

1. Emission Level(dBuV/m) = Raw Value(dBuV) + Correction Factor(dB/m)
2. Correction Factor(dB/m) = Antenna Factor(dB/m) + Cable Factor(dB) – Pre-Amplifier Factor(dB)
3. The other emission levels were very low against the limit.
4. Margin value = Emission Level – Limit value

4.2 Conducted Emission Measurement

4.2.1 Limits of Conducted Emission Measurement

Frequency (MHz)	Conducted Limit (dBuV)	
	Quasi-peak	Average
0.15 - 0.5	66 - 56	56 - 46
0.50 - 5.0	56	46
5.0 - 30.0	60	50

Note: 1. The lower limit shall apply at the transition frequencies.

2. The limit decreases in line with the logarithm of the frequency in the range of 0.15 to 0.50MHz.

4.2.2 Test Instruments

Description & Manufacturer	Model No.	Serial No.	Cal. Date	Cal. Due
Test Receiver ROHDE & SCHWARZ	ESCI	100613	Nov. 23, 2017	Nov. 22, 2018
RF signal cable (with 10dB PAD) Woken	5D-FB	Cable-cond1-01	Sep. 05, 2017	Sep. 04, 2018
LISN ROHDE & SCHWARZ (EUT)	ESH3-Z5	835239/001	Mar. 06, 2018	Mar. 05, 2019
LISN ROHDE & SCHWARZ (Peripheral)	ESH3-Z5	100311	Aug. 15, 2017	Aug. 14, 2018
Software ADT	BV ADT_Cond_ V7.3.7.4	NA	NA	NA
Extension Cord	Extension Cord	1-1	Dec. 22, 2017	Dec. 21, 2018

Note: 1. The calibration interval of the above test instruments is 12 months and the calibrations are traceable to NML/ROC and NIST/USA.

2. The test was performed in HwaYa Shielded Room 1.

3. The VCCI Site Registration No. is C-2040.

4.2.3 Test Procedures

- a. The EUT was placed 0.4 meters from the conducting wall of the shielded room with EUT being connected to the power mains through a line impedance stabilization network (LISN). Other support units were connected to the power mains through another LISN. The two LISNs provide 50 ohm/ 50uH of coupling impedance for the measuring instrument.
- b. Both lines of the power mains connected to the EUT were checked for maximum conducted interference.
- c. The frequency range from 150kHz to 30MHz was searched. Emission levels under (Limit - 20dB) was not recorded.

NOTE: The resolution bandwidth and video bandwidth of test receiver is 9kHz for quasi-peak detection (QP) and average detection (AV) at frequency 0.15MHz-30MHz.

4.2.4 Deviation from Test Standard

No deviation.

4.2.5 Test Setup

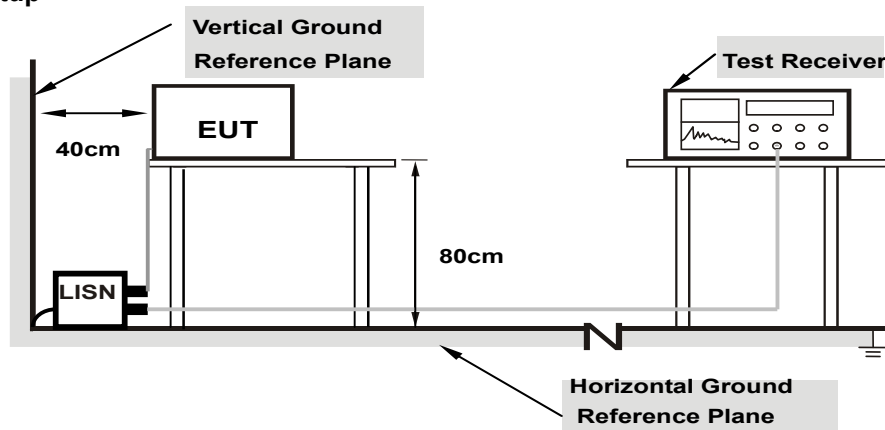

Note: 1.Support units were connected to second LISN.

For the actual test configuration, please refer to the attached file (Test Setup Photo).

4.2.6 EUT Operating Conditions

Same as 4.1.6.

4.2.7 Test Results

Worst-case data: 802.11a

Phase	Line (L)	Detector Function	Quasi-Peak (QP) / Average (AV)
Test Mode	A		

No	Freq. [MHz]	Corr. Factor (dB)	Reading Value		Emission Level		Limit		Margin	
			[dB (uV)]		[dB (uV)]		[dB (uV)]		(dB)	
			Q.P.	AV.	Q.P.	AV.	Q.P.	AV.	Q.P.	AV.
1	0.16173	10.16	35.49	21.00	45.65	31.16	65.37	55.37	-19.72	-24.21
2	0.18754	10.16	32.49	18.67	42.65	28.83	64.14	54.14	-21.49	-25.31
3	0.21256	10.16	28.09	15.54	38.25	25.70	63.10	53.10	-24.85	-27.40
4	0.26730	10.17	21.88	8.10	32.05	18.27	61.20	51.20	-29.15	-32.93
5	0.38069	10.20	24.88	19.82	35.08	30.02	58.26	48.26	-23.18	-18.24
6	0.93568	10.18	10.17	5.66	20.35	15.84	56.00	46.00	-35.65	-30.16

Remarks:

1. Q.P. and AV. are abbreviations of quasi-peak and average individually.
2. The emission levels of other frequencies were very low against the limit.
3. Margin value = Emission level - Limit value
4. Correction factor = Insertion loss + Cable loss
5. Emission Level = Correction Factor + Reading Value.

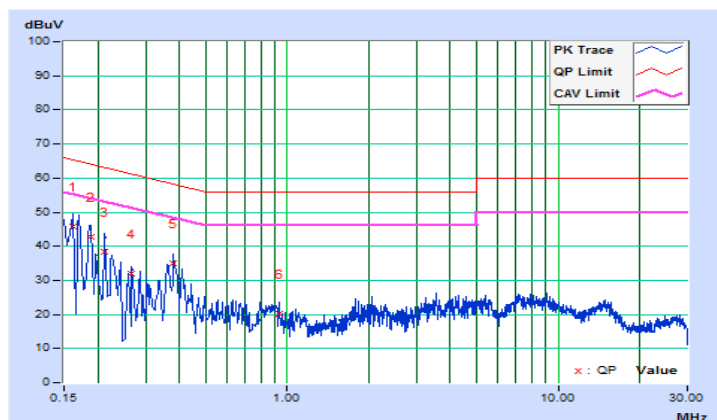

Phase	Neutral (N)	Detector Function	Quasi-Peak (QP) / Average (AV)
Test Mode	A		

No	Freq. [MHz]	Corr. Factor (dB)	Reading Value [dB (uV)]		Emission Level [dB (uV)]		Limit [dB (uV)]		Margin (dB)	
			Q.P.	AV.	Q.P.	AV.	Q.P.	AV.	Q.P.	AV.
			1	0.16181	10.15	35.72	19.59	45.87	29.74	65.37
2	0.17744	10.15	34.35	18.25	44.50	28.40	64.60	54.60	-20.10	-26.20
3	0.20474	10.16	30.41	16.17	40.57	26.33	63.42	53.42	-22.85	-27.09
4	0.25166	10.17	22.75	6.32	32.92	16.49	61.70	51.70	-28.78	-35.21
5	0.38069	10.19	23.89	16.31	34.08	26.50	58.26	48.26	-24.18	-21.76
6	0.69740	10.20	10.17	7.11	20.37	17.31	56.00	46.00	-35.63	-28.69

Remarks:

1. Q.P. and AV. are abbreviations of quasi-peak and average individually.
2. The emission levels of other frequencies were very low against the limit.
3. Margin value = Emission level - Limit value
4. Correction factor = Insertion loss + Cable loss
5. Emission Level = Correction Factor + Reading Value.

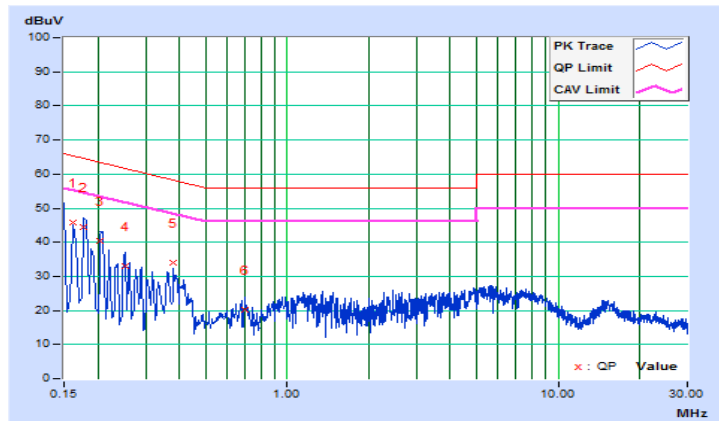

Phase	Line (L)	Detector Function	Quasi-Peak (QP) / Average (AV)
Test Mode	B		

No	Freq. [MHz]	Corr. Factor (dB)	Reading Value [dB (uV)]		Emission Level [dB (uV)]		Limit [dB (uV)]		Margin (dB)	
			Q.P.	AV.	Q.P.	AV.	Q.P.	AV.	Q.P.	AV.
			1	0.20350	10.15	37.86	29.00	48.01	39.15	63.47
2	0.27480	10.17	37.27	25.61	47.44	35.78	60.97	50.97	-13.53	-15.19
3	0.32786	10.19	39.50	31.03	49.69	41.22	59.51	49.51	-9.82	-8.29
4	0.38503	10.20	33.93	22.65	44.13	32.85	58.17	48.17	-14.04	-15.32
5	0.46669	10.20	33.10	22.30	43.30	32.50	56.57	46.57	-13.27	-14.07
6	0.53709	10.20	32.96	21.53	43.16	31.73	56.00	46.00	-12.84	-14.27

Remarks:

1. Q.P. and AV. are abbreviations of quasi-peak and average individually.
2. The emission levels of other frequencies were very low against the limit.
3. Margin value = Emission level - Limit value
4. Correction factor = Insertion loss + Cable loss
5. Emission Level = Correction Factor + Reading Value.

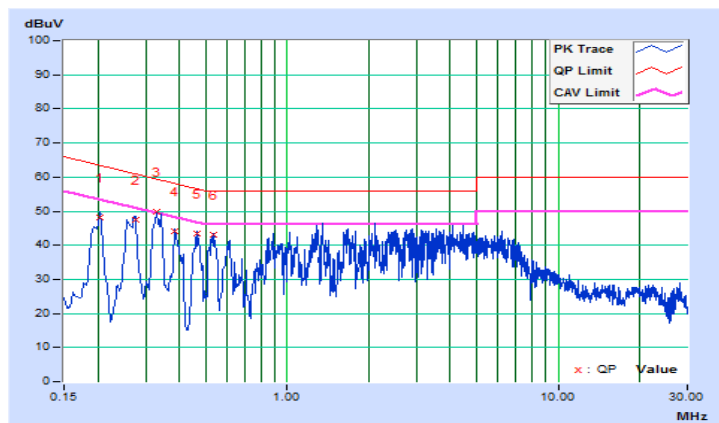

Phase	Neutral (N)	Detector Function	Quasi-Peak (QP) / Average (AV)
Test Mode	B		

No	Freq. [MHz]	Corr. Factor (dB)	Reading Value [dB (uV)]		Emission Level [dB (uV)]		Limit [dB (uV)]		Margin (dB)	
			Q.P.	AV.	Q.P.	AV.	Q.P.	AV.	Q.P.	AV.
			1	0.19305	10.16	37.38	27.40	47.54	37.56	63.90
2	0.26339	10.17	37.73	30.50	47.90	40.67	61.32	51.32	-13.42	-10.65
3	0.33221	10.19	38.67	30.35	48.86	40.54	59.40	49.40	-10.54	-8.86
4	0.38460	10.19	34.86	23.15	45.05	33.34	58.18	48.18	-13.13	-14.84
5	0.54089	10.20	33.39	22.39	43.59	32.59	56.00	46.00	-12.41	-13.41
6	0.61138	10.20	31.15	19.46	41.35	29.66	56.00	46.00	-14.65	-16.34

Remarks:

1. Q.P. and AV. are abbreviations of quasi-peak and average individually.
2. The emission levels of other frequencies were very low against the limit.
3. Margin value = Emission level - Limit value
4. Correction factor = Insertion loss + Cable loss
5. Emission Level = Correction Factor + Reading Value.

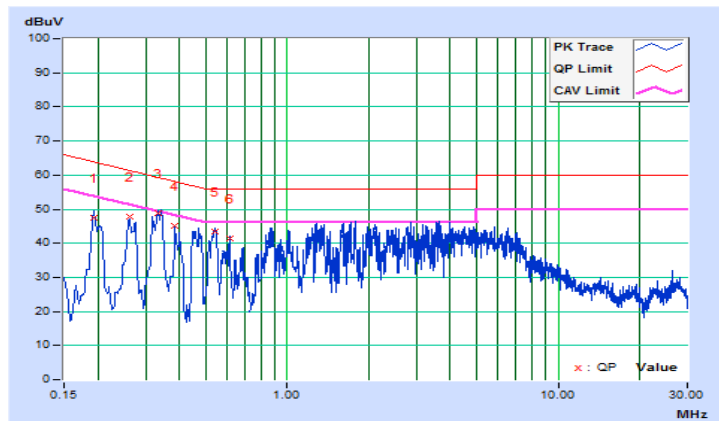

4.3 Transmit Power Measurement

4.3.1 Limits of Transmit Power Measurement

Operation Band	EUT Category		LIMIT
U-NII-1	-	Outdoor Wi-Fi & BLE Array AP	1 Watt (30 dBm) (Max. e.i.r.p \leq 125mW(21 dBm) at any elevation angle above 30 degrees as measured from the horizon)
	-	Fixed point-to-point Wi-Fi & BLE Array AP	1 Watt (30 dBm)
	-	Indoor Wi-Fi & BLE Array AP	1 Watt (30 dBm)
	-	Mobile and Portable client device	250mW (24 dBm)
U-NII-2A	√		250mW (24 dBm) or 11 dBm+10 log B*
U-NII-2C	√		250mW (24 dBm) or 11 dBm+10 log B*
U-NII-3	√		1 Watt (30 dBm)

*B is the 26 dB emission bandwidth in megahertz

Per KDB 662911 Method of conducted output power measurement on IEEE 802.11 devices,

Array Gain = 0 dB (i.e., no array gain) for $N_{ANT} \leq 4$;

Array Gain = 0 dB (i.e., no array gain) for channel widths ≥ 40 MHz for any N_{ANT} ;

Array Gain = $5 \log(N_{ANT}/N_{SS})$ dB or 3 dB, whichever is less for 20-MHz channel widths with $N_{ANT} \geq 5$.

For power measurements on all other devices: Array Gain = $10 \log(N_{ANT}/N_{SS})$ dB.

4.3.2 Test Setup

For Power Output Measurement

For 802.11a, 802.11n (HT20), 802.11n (HT40), 802.11ac (VHT20), 802.11ac (VHT40)

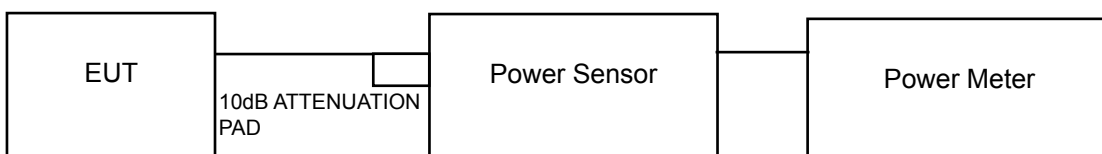

For 802.11ac (VHT80)

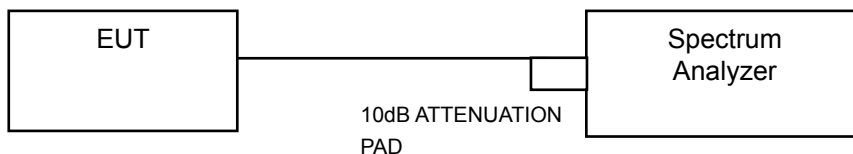

For 26dB Bandwidth

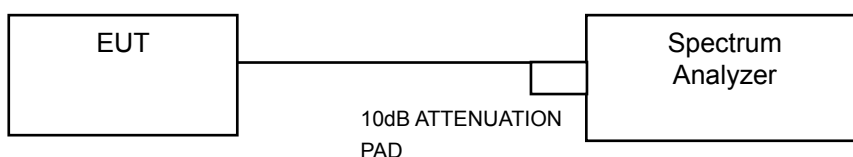

4.3.3 Test Instruments

Refer to section 4.1.2 to get information of above instrument.

4.3.4 Test Procedure

FOR AVERAGE POWER MEASUREMENT

For 802.11a, 802.11n (HT20), 802.11n (HT40), 802.11ac (VHT20), 802.11ac (VHT40)

Method PM is used to perform output power measurement, trigger and gating function of wide band power meter is enabled to measure max output power of TX on burst and set the detector to AVERAGE. Duty factor is not added to measured value.

For 802.11ac (VHT80)

- 1) Set span to encompass the entire 26 dB EBW (or, alternatively, the entire 99% occupied bandwidth) of the signal.
- 2) Set sweep trigger to "free run".
- 3) Set RBW = 1 MHz.
- 4) Set VBW \geq 3 MHz
- 5) Number of points in sweep \geq 2 Span / RBW.
- 6) Sweep time \leq (number of points in sweep) * T
- 7) Using emission bandwidth to determine the frequency span for integration the channel bandwidth.
- 8) Detector = RMS.
- 9) Trace mode = max hold.
- 10) Allow max hold to run for at least 60 seconds, or longer as needed to allow the trace to stabilize.

For 26dB Bandwidth

- 1) Set RBW = approximately 1% of the emission bandwidth.
- 2) Set the VBW > RBW.
- 3) Detector = Peak.
- 4) Trace mode = max hold.
- 5) Measure the maximum width of the emission that is 26 dB down from the peak of the emission. Compare this with the RBW setting of the analyzer. Readjust RBW and repeat measurement as needed until the RBW/EBW ratio is approximately 1%.

4.3.5 Deviation from Test Standard

No deviation.

4.3.6 EUT Operating Conditions

The software provided by client to enable the EUT under transmission condition continuously at lowest, middle and highest channel frequencies individually.

4.3.7 Test Result

POWER OUTPUT:

CDD Mode

802.11a

Chan.	Freq. (MHz)	Maximum Conducted Power (dBm)		Total Power (mW)	Total Power (dBm)	Power Limit (dBm)	Pass / Fail
		Chain 0	Chain 1				
52	5260	16.47	16.41	88.113	19.45	23.86	Pass
60	5300	16.69	16.63	92.692	19.67	23.88	Pass
64	5320	16.79	16.83	95.948	19.82	23.87	Pass
100	5500	16.21	16.58	87.282	19.41	23.87	Pass
116	5580	16.01	16.15	81.112	19.09	23.90	Pass
140	5700	16.01	16.12	80.828	19.08	23.83	Pass
144 (For U-NII-2C)	5720	15.84	16.03	82.849	19.18	22.62	Pass
144 (For U-NII-3)	5720	10.91	11.01	26.345	14.21	30.00	Pass

Note:

Chain 0

1. $11\text{dBm} + 10\log(20.00) = 24.01\text{ dBm} > 24\text{dBm}$.
2. $11\text{dBm} + 10\log(19.91) = 23.99\text{ dBm} < 24\text{dBm}$.
3. $11\text{dBm} + 10\log(19.71) = 23.95\text{ dBm} < 24\text{dBm}$.
4. $11\text{dBm} + 10\log(19.61) = 23.92\text{ dBm} < 24\text{dBm}$.
5. $11\text{dBm} + 10\log(19.70) = 23.94\text{ dBm} < 24\text{dBm}$.
6. $11\text{dBm} + 10\log(19.63) = 23.93\text{ dBm} < 24\text{dBm}$.
7. $11\text{dBm} + 10\log(5725.00-5710.20) = 22.70\text{dBm} < 24\text{dBm}$.

Chain 1

1. $11\text{dBm} + 10\log(19.34) = 23.86\text{ dBm} < 24\text{dBm}$.
2. $11\text{dBm} + 10\log(19.42) = 23.88\text{ dBm} < 24\text{dBm}$.
3. $11\text{dBm} + 10\log(19.40) = 23.87\text{ dBm} < 24\text{dBm}$.
4. $11\text{dBm} + 10\log(19.39) = 23.87\text{ dBm} < 24\text{dBm}$.
5. $11\text{dBm} + 10\log(19.51) = 23.90\text{ dBm} < 24\text{dBm}$.
6. $11\text{dBm} + 10\log(19.20) = 23.83\text{ dBm} < 24\text{dBm}$.
7. $11\text{dBm} + 10\log(5725.00-5710.46) = 22.62\text{dBm} < 24\text{dBm}$.

802.11n (HT20)

Chan.	Freq. (MHz)	Maximum Conducted Power (dBm)		Total Power (mW)	Total Power (dBm)	Power Limit (dBm)	Pass / Fail
		Chain 0	Chain 1				
52	5260	17.55	17.58	114.165	20.58	24.00	Pass
60	5300	17.65	17.74	117.639	20.71	24.00	Pass
64	5320	17.52	17.52	112.988	20.53	24.00	Pass
100	5500	17.23	17.82	113.379	20.55	24.00	Pass
116	5580	16.88	17.26	101.964	20.08	24.00	Pass
140	5700	17.46	17.52	112.213	20.50	24.00	Pass
144 (For U-NII-2C)	5720	15.67	15.71	74.137	18.70	22.77	Pass
144 (For U-NII-3)	5720	10.99	11.13	25.532	14.07	30.00	Pass

Note:

Chain 0

1. $11\text{dBm} + 10\log(20.57) = 24.13\text{ dBm} > 24\text{dBm}$.
2. $11\text{dBm} + 10\log(20.97) = 24.22\text{ dBm} > 24\text{dBm}$.
3. $11\text{dBm} + 10\log(20.54) = 24.13\text{ dBm} > 24\text{dBm}$.
4. $11\text{dBm} + 10\log(20.62) = 24.14\text{ dBm} > 24\text{dBm}$.
5. $11\text{dBm} + 10\log(20.69) = 24.16\text{ dBm} > 24\text{dBm}$.
6. $11\text{dBm} + 10\log(20.53) = 24.12\text{ dBm} > 24\text{dBm}$.
7. $11\text{dBm} + 10\log(5725.00-5709.67) = 22.86\text{dBm} < 24\text{dBm}$.

Chain 1

1. $11\text{dBm} + 10\log(20.46) = 24.11\text{ dBm} > 24\text{dBm}$.
2. $11\text{dBm} + 10\log(20.49) = 24.12\text{ dBm} > 24\text{dBm}$.
3. $11\text{dBm} + 10\log(20.50) = 24.12\text{ dBm} > 24\text{dBm}$.
4. $11\text{dBm} + 10\log(20.58) = 24.13\text{ dBm} > 24\text{dBm}$.
5. $11\text{dBm} + 10\log(20.66) = 24.15\text{ dBm} > 24\text{dBm}$.
6. $11\text{dBm} + 10\log(20.51) = 24.12\text{ dBm} > 24\text{dBm}$.
7. $11\text{dBm} + 10\log(5725.00-5709.95) = 22.77\text{dBm} < 24\text{dBm}$.

802.11n (HT40)

Chan.	Freq. (MHz)	Maximum Conducted Power (dBm)		Total Power (mW)	Total Power (dBm)	Power Limit (dBm)	Pass / Fail
		Chain 0	Chain 1				
54	5270	19.75	19.84	190.789	22.81	24.00	Pass
62	5310	16.94	16.86	97.960	19.91	24.00	Pass
102	5510	14.32	14.92	58.086	17.64	24.00	Pass
110	5550	19.05	19.68	173.250	22.39	24.00	Pass
134	5670	18.69	18.88	151.229	21.80	24.00	Pass
142 (For U-NII-2C)	5710	18.25	18.32	140.223	21.47	24.00	Pass
142 (For U-NII-3)	5710	10.02	10.29	21.579	13.34	30.00	Pass

Note:

Chain 0

1. $11\text{dBm} + 10\log(40.68) = 27.09\text{ dBm} > 24\text{dBm}$.
2. $11\text{dBm} + 10\log(40.70) = 27.10\text{ dBm} > 24\text{dBm}$.
3. $11\text{dBm} + 10\log(40.71) = 27.10\text{ dBm} > 24\text{dBm}$.
4. $11\text{dBm} + 10\log(40.78) = 27.10\text{ dBm} > 24\text{dBm}$.
5. $11\text{dBm} + 10\log(40.52) = 27.08\text{ dBm} > 24\text{dBm}$.
6. $11\text{dBm} + 10\log(5725.00-5689.50) = 26.50\text{dBm} > 24\text{dBm}$.

Chain 1

1. $11\text{dBm} + 10\log(40.31) = 27.05\text{ dBm} > 24\text{dBm}$.
2. $11\text{dBm} + 10\log(40.70) = 27.10\text{ dBm} > 24\text{dBm}$.
3. $11\text{dBm} + 10\log(40.66) = 27.09\text{ dBm} > 24\text{dBm}$.
4. $11\text{dBm} + 10\log(40.32) = 27.06\text{ dBm} > 24\text{dBm}$.
5. $11\text{dBm} + 10\log(40.30) = 27.05\text{ dBm} > 24\text{dBm}$.
6. $11\text{dBm} + 10\log(5725.00-5689.62) = 26.49\text{dBm} > 24\text{dBm}$.

802.11ac (VHT80)

Chan.	Freq. (MHz)	Maximum Conducted Power (dBm)		Total Power (mW)	Total Power (dBm)	Power Limit (dBm)	Pass / Fail
		Chain 0	Chain 1				
58	5290	14.28	14.22	53.216	17.26	24.00	Pass
106	5530	14.07	14.65	54.701	17.38	24.00	Pass
138 (For U-NII-2C)	5690	18.32	18.39	149.014	21.73	24.00	Pass
138 (For U-NII-3)	5690	7.63	8.15	13.411	11.27	30.00	Pass

Note:

Chain 0

1. $11\text{dBm} + 10\log(84.13) = 30.25\text{ dBm} > 24\text{dBm}$.
2. $11\text{dBm} + 10\log(84.06) = 30.25\text{ dBm} > 24\text{dBm}$.
3. $11\text{dBm} + 10\log(5725.00-5648.26) = 29.85\text{dBm} > 24\text{dBm}$.

Chain 1

1. $11\text{dBm} + 10\log(83.34) = 30.21\text{ dBm} > 24\text{dBm}$.
2. $11\text{dBm} + 10\log(83.78) = 30.23\text{ dBm} > 24\text{dBm}$.
3. $11\text{dBm} + 10\log(5725.00-5648.00) = 29.86\text{dBm} > 24\text{dBm}$.

Beamforming Mode

802.11n (HT20)

Chan.	Freq. (MHz)	Maximum Conducted Power (dBm)		Total Power (mW)	Total Power (dBm)	Power Limit (dBm)	Pass / Fail
		Chain 0	Chain 1				
52	5260	14.54	14.57	57.087	17.57	21.00	Pass
60	5300	14.64	14.73	58.824	17.70	21.00	Pass
64	5320	14.51	14.51	56.498	17.52	21.00	Pass
100	5500	14.22	14.81	56.693	17.54	21.00	Pass
116	5580	13.87	14.25	50.985	17.07	21.00	Pass
140	5700	14.45	14.51	56.110	17.49	21.00	Pass
144 (For U-NII-2C)	5720	12.66	12.70	37.071	15.69	19.77	Pass
144 (For U-NII-3)	5720	7.98	8.12	12.767	11.06	27.00	Pass

Note:

*For U-NII-2a & U-NII-2c Band: Directional gain = $10 \log[(10^{G1/20} + 10^{G2/20} + \dots + 10^{GN/20})^2/2] = 9 \text{ dBi} > 6 \text{ dBi}$, so the power limit shall be reduced to $24 - (9 - 6) = 21.00 \text{ dBm}$.

* For chan. 144(U-NII-2C): Directional gain = $10 \log[(10^{G1/20} + 10^{G2/20} + \dots + 10^{GN/20})^2/2] = 9 \text{ dBi} > 6 \text{ dBi}$, so the power limit shall be reduced to $22.77 - (9 - 6) = 19.77 \text{ dBm}$.

* For chan. 144(U-NII-3): Directional gain = $10 \log[(10^{G1/20} + 10^{G2/20} + \dots + 10^{GN/20})^2/2] = 9 \text{ dBi} > 6 \text{ dBi}$, so the power limit shall be reduced to $30 - (9 - 6) = 27.00 \text{ dBm}$.

Note:

Chain 0

1. $11 \text{ dBm} + 10 \log(20.57) = 24.13 \text{ dBm} > 24 \text{ dBm}$.
2. $11 \text{ dBm} + 10 \log(20.97) = 24.22 \text{ dBm} > 24 \text{ dBm}$.
3. $11 \text{ dBm} + 10 \log(20.54) = 24.13 \text{ dBm} > 24 \text{ dBm}$.
4. $11 \text{ dBm} + 10 \log(20.62) = 24.14 \text{ dBm} > 24 \text{ dBm}$.
5. $11 \text{ dBm} + 10 \log(20.69) = 24.16 \text{ dBm} > 24 \text{ dBm}$.
6. $11 \text{ dBm} + 10 \log(20.53) = 24.12 \text{ dBm} > 24 \text{ dBm}$.
7. $11 \text{ dBm} + 10 \log(5725.00-5709.67) = 22.86 \text{ dBm} < 24 \text{ dBm}$.

Chain 1

1. $11 \text{ dBm} + 10 \log(20.46) = 24.11 \text{ dBm} > 24 \text{ dBm}$.
2. $11 \text{ dBm} + 10 \log(20.49) = 24.12 \text{ dBm} > 24 \text{ dBm}$.
3. $11 \text{ dBm} + 10 \log(20.50) = 24.12 \text{ dBm} > 24 \text{ dBm}$.
4. $11 \text{ dBm} + 10 \log(20.58) = 24.13 \text{ dBm} > 24 \text{ dBm}$.
5. $11 \text{ dBm} + 10 \log(20.66) = 24.15 \text{ dBm} > 24 \text{ dBm}$.
6. $11 \text{ dBm} + 10 \log(20.51) = 24.12 \text{ dBm} > 24 \text{ dBm}$.
7. $11 \text{ dBm} + 10 \log(5725.00-5709.95) = 22.77 \text{ dBm} < 24 \text{ dBm}$.

802.11n (HT40)

Chan.	Freq. (MHz)	Maximum Conducted Power (dBm)		Total Power (mW)	Total Power (dBm)	Power Limit (dBm)	Pass / Fail
		Chain 0	Chain 1				
54	5270	16.74	16.83	95.401	19.80	21.00	Pass
62	5310	13.93	13.85	48.983	16.90	21.00	Pass
102	5510	11.31	10.91	25.852	14.12	21.00	Pass
110	5550	16.04	16.67	86.631	19.38	21.00	Pass
134	5670	15.68	15.87	75.620	18.79	21.00	Pass
142 (For U-NII-2C)	5710	15.24	15.31	70.118	18.46	21.00	Pass
142 (For U-NII-3)	5710	7.01	7.28	10.790	10.33	27.00	Pass

Note:

For U-NII-2a & U-NII-2c Band: Directional gain = $10 \log[(10^{G1/20} + 10^{G2/20} + \dots + 10^{GN/20})^2/2] = 9 \text{ dBi} > 6 \text{ dBi}$, so the power limit shall be reduced to $24 - (9 - 6) = 21.00 \text{ dBm}$.

* For chan. 142(U-NII-2C): Directional gain = $10 \log[(10^{G1/20} + 10^{G2/20} + \dots + 10^{GN/20})^2/2] = 9 \text{ dBi} > 6 \text{ dBi}$, so the power limit shall be reduced to $24 - (9 - 6) = 21.00 \text{ dBm}$.

* For chan. 142(U-NII-3): Directional gain = $10 \log[(10^{G1/20} + 10^{G2/20} + \dots + 10^{GN/20})^2/2] = 9 \text{ dBi} > 6 \text{ dBi}$, so the power limit shall be reduced to $30 - (9 - 6) = 27.00 \text{ dBm}$.

Note:

Chain 0

1. $11 \text{ dBm} + 10 \log(40.68) = 27.09 \text{ dBm} > 24 \text{ dBm}$.
2. $11 \text{ dBm} + 10 \log(40.70) = 27.10 \text{ dBm} > 24 \text{ dBm}$.
3. $11 \text{ dBm} + 10 \log(40.71) = 27.10 \text{ dBm} > 24 \text{ dBm}$.
4. $11 \text{ dBm} + 10 \log(40.78) = 27.10 \text{ dBm} > 24 \text{ dBm}$.
5. $11 \text{ dBm} + 10 \log(40.52) = 27.08 \text{ dBm} > 24 \text{ dBm}$.
6. $11 \text{ dBm} + 10 \log(5725.00 - 5689.50) = 26.50 \text{ dBm} > 24 \text{ dBm}$.

Chain 1

1. $11 \text{ dBm} + 10 \log(40.31) = 27.05 \text{ dBm} > 24 \text{ dBm}$.
2. $11 \text{ dBm} + 10 \log(40.70) = 27.10 \text{ dBm} > 24 \text{ dBm}$.
3. $11 \text{ dBm} + 10 \log(40.66) = 27.09 \text{ dBm} > 24 \text{ dBm}$.
4. $11 \text{ dBm} + 10 \log(40.32) = 27.06 \text{ dBm} > 24 \text{ dBm}$.
5. $11 \text{ dBm} + 10 \log(40.30) = 27.05 \text{ dBm} > 24 \text{ dBm}$.
6. $11 \text{ dBm} + 10 \log(5725.00 - 5689.62) = 26.49 \text{ dBm} > 24 \text{ dBm}$.

802.11ac (VHT80)

Chan.	Freq. (MHz)	Maximum Conducted Power (dBm)		Total Power (mW)	Total Power (dBm)	Power Limit (dBm)	Pass / Fail
		Chain 0	Chain 1				
58	5290	11.27	11.21	26.610	14.25	21.00	Pass
106	5530	11.06	11.64	27.352	14.37	21.00	Pass
138 (For U-NII-2C)	5690	15.31	15.38	74.513	18.72	21.00	Pass
138 (For U-NII-3)	5690	4.62	5.14	6.706	8.26	27.00	Pass

Note:

For U-NII-2a & U-NII-2c Band: Directional gain = $10 \log[(10^{G1/20} + 10^{G2/20} + \dots + 10^{GN/20})^2/2] = 9 \text{ dBi} > 6 \text{ dBi}$, so the power limit shall be reduced to $24 - (9 - 6) = 21.00 \text{ dBm}$.

For U-NII-3 Band: Directional gain = $10 \log[(10^{G1/20} + 10^{G2/20} + \dots + 10^{GN/20})^2/2] = 9 \text{ dBi} > 6 \text{ dBi}$, so the power limit shall be reduced to $30 - (9 - 6) = 27.00 \text{ dBm}$.

Note:

Chain 0

1. $11 \text{ dBm} + 10 \log(84.13) = 30.25 \text{ dBm} > 24 \text{ dBm}$.
2. $11 \text{ dBm} + 10 \log(84.06) = 30.25 \text{ dBm} > 24 \text{ dBm}$.
3. $11 \text{ dBm} + 10 \log(5725.00 - 5648.26) = 29.85 \text{ dBm} > 24 \text{ dBm}$.

Chain 1

1. $11 \text{ dBm} + 10 \log(83.34) = 30.21 \text{ dBm} > 24 \text{ dBm}$.
2. $11 \text{ dBm} + 10 \log(83.78) = 30.23 \text{ dBm} > 24 \text{ dBm}$.
3. $11 \text{ dBm} + 10 \log(5725.00 - 5648.00) = 29.86 \text{ dBm} > 24 \text{ dBm}$.

26dB BANDWIDTH:
802.11a

Chan.	Freq. (MHz)	26dBc Bandwidth (MHz)	
		Chain 0	Chain 1
52	5260	20.00	19.34
60	5300	19.91	19.42
64	5320	19.71	19.40
100	5500	19.61	19.39
116	5580	19.70	19.51
140	5700	19.63	19.20
144 (For U-NII-2C)	5720	14.80	14.54

802.11n (HT20)

Chan.	Freq. (MHz)	26dBc Bandwidth (MHz)	
		Chain 0	Chain 1
52	5260	20.57	20.46
60	5300	20.97	20.49
64	5320	20.54	20.50
100	5500	20.62	20.58
116	5580	20.69	20.66
140	5700	20.53	20.51
144 (For U-NII-2C)	5720	15.34	15.06

802.11n (HT40)

Chan.	Freq. (MHz)	26dBc Bandwidth (MHz)	
		Chain 0	Chain 1
54	5270	40.68	40.31
62	5310	40.70	40.70
102	5510	40.71	40.66
110	5550	40.78	40.32
134	5670	40.52	40.30
142 (For U-NII-2C)	5710	35.50	35.39



802.11ac (VHT80)

Chan.	Freq. (MHz)	26dBc Bandwidth (MHz)	
		Chain 0	Chain 1
58	5290	84.13	83.34
106	5530	84.06	83.78
138 (For U-NII-2C)	5690	76.75	77.01

Spectrum Plot of Worst Value

802.11a / Chain 0 / Ch 52

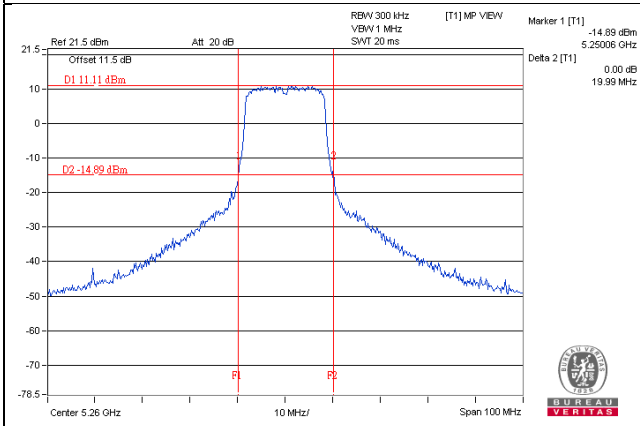

802.11n (HT20) / Chain 0 / Ch 60

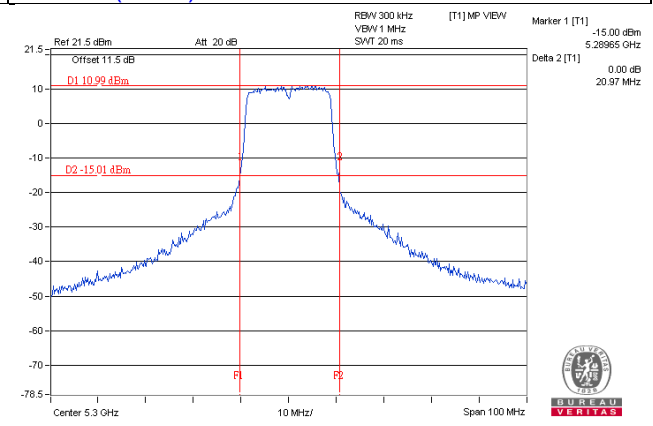

802.11n (HT40) / Chain 0 / Ch 110

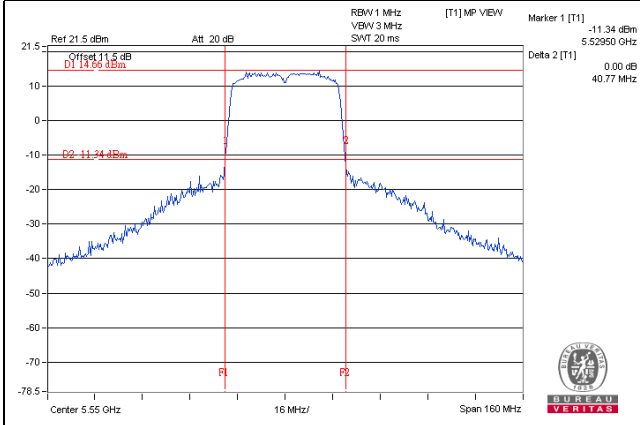

802.11ac (VHT80) / Chain 0 / Ch 58

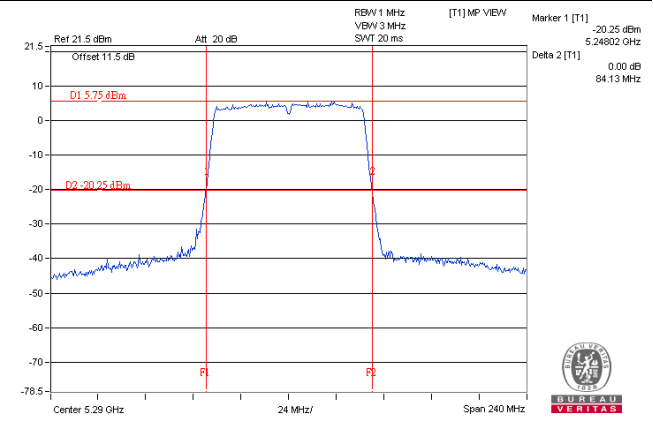

4.4 Occupied Bandwidth Measurement

4.4.1 Test Setup



4.4.2 Test Instruments

Refer to section 4.1.2 to get information of above instrument.

4.4.3 Test Procedure

The transmitter output was connected to the spectrum analyzer through an attenuator. The bandwidth of the fundamental frequency was measured by spectrum analyzer with resolution bandwidth in the range of 1% to 5% of the anticipated emission bandwidth, and a video bandwidth at least 3x the resolution bandwidth and set the detector to SAMPLE. The width of a frequency band such that, below the lower and above the upper frequency limits, the mean powers emitted are each equal to a specified percentage 0.5 %of the total mean power of a given emission.

4.4.4 Test Results

802.11a

Chan.	Freq. (MHz)	Occupied Bandwidth (MHz)	
		Chain 0	Chain 1
52	5260	16.44	16.44
60	5300	16.44	16.44
64	5320	16.44	16.44
100	5500	16.44	16.44
116	5580	16.44	16.44
140	5700	16.44	16.44
144 (For U-NII-2C)	5720	13.28	13.28

802.11n (HT20)

Chan.	Freq. (MHz)	Occupied Bandwidth (MHz)	
		Chain 0	Chain 1
52	5260	17.64	17.64
60	5300	17.64	17.64
64	5320	17.64	17.64
100	5500	17.64	17.64
116	5580	17.64	17.64
140	5700	17.64	17.64
144 (For U-NII-2C)	5720	13.88	13.88

802.11n (HT40)

Chan.	Freq. (MHz)	Occupied Bandwidth (MHz)	
		Chain 0	Chain 1
54	5270	36.24	36.24
62	5310	36.24	36.12
102	5510	36.24	36.12
110	5550	36.24	36.12
134	5670	36.12	36.12
142 (For U-NII-2C)	5710	33.24	33.12



BUREAU VERITAS

802.11ac (VHT80)

Chan.	Freq. (MHz)	Occupied Bandwidth (MHz)	
		Chain 0	Chain 1
58	5290	75.60	75.88
106	5530	75.88	75.60
138 (For U-NII-2C)	5690	73.16	72.92

Spectrum Plot of Worst Value

802.11a

802.11n (HT20)

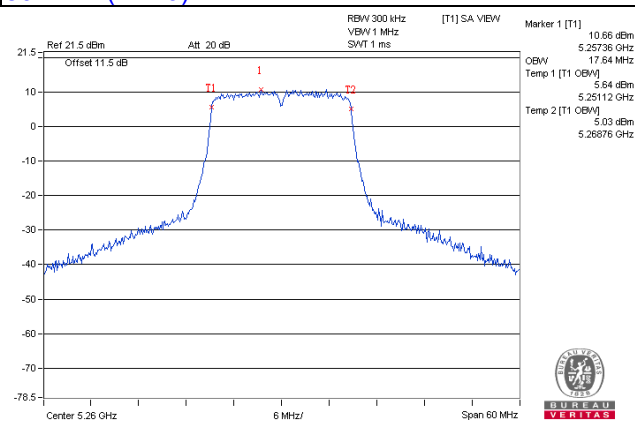
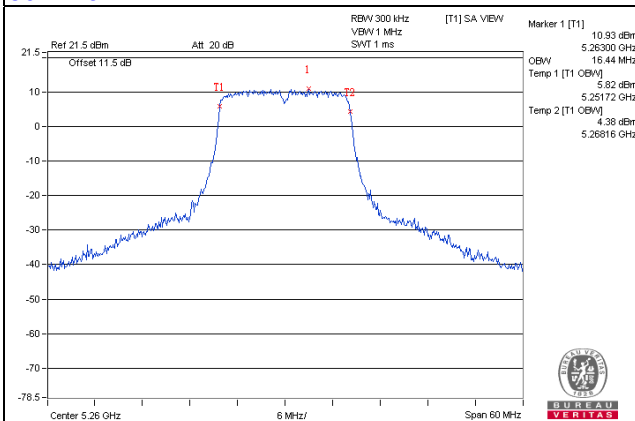

802.11n (HT40)

802.11ac (VHT80)

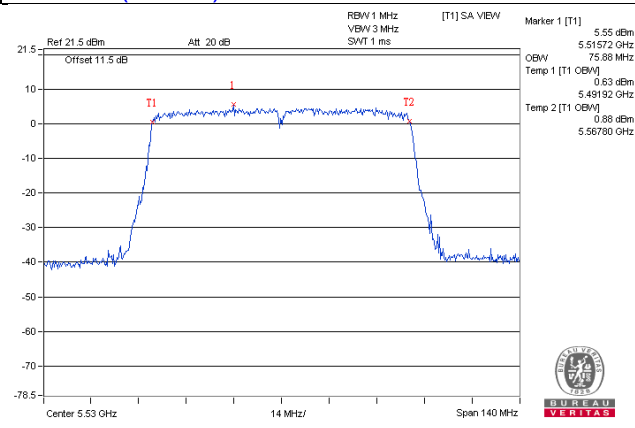
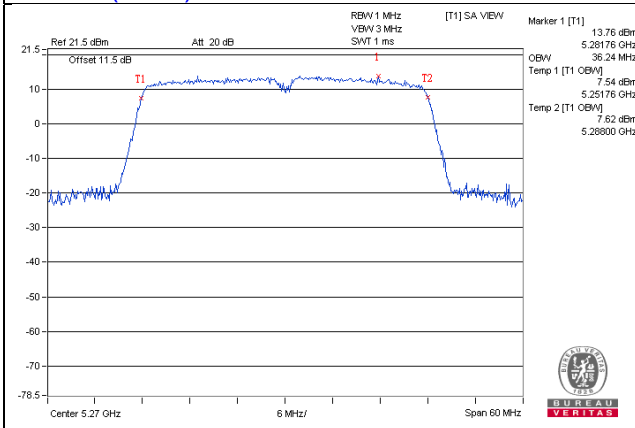

EUT MAXIMUM CONDUCTED POWER

CDD Mode

802.11a

Frequency Band (MHz)	Max. Power	
	Output Power (mW)	Output Power (dBm)
5250~5350	95.948	19.82
5470~5725	87.282	19.41

Note: Manufacturer provides Transmit Power Control description to meet this requirement.

802.11n (HT20)

Frequency Band (MHz)	Max. Power	
	Output Power (mW)	Output Power (dBm)
5250~5350	117.639	20.71
5470~5725	113.379	20.55

Note: Manufacturer provides Transmit Power Control description to meet this requirement.

802.11n (HT40)

Frequency Band (MHz)	Max. Power	
	Output Power (mW)	Output Power (dBm)
5250~5350	190.789	22.81
5470~5725	173.250	22.39

Note: Manufacturer provides Transmit Power Control description to meet this requirement.

802.11ac (VHT80)

Frequency Band (MHz)	Max. Power	
	Output Power (mW)	Output Power (dBm)
5250~5350	53.216	17.26
5470~5725	149.014	21.73

Note: Manufacturer provides Transmit Power Control description to meet this requirement.

Beamforming Mode

802.11n (HT20)

Frequency Band (MHz)	Max. Power	
	Output Power (mW)	Output Power (dBm)
5250~5350	58.824	17.70
5470~5725	56.693	17.54

Note: Manufacturer provides Transmit Power Control description to meet this requirement.

802.11n (HT40)

Frequency Band (MHz)	Max. Power	
	Output Power (mW)	Output Power (dBm)
5250~5350	95.401	19.80
5470~5725	86.631	19.38

Note: Manufacturer provides Transmit Power Control description to meet this requirement.

802.11ac (VHT80)

Frequency Band (MHz)	Max. Power	
	Output Power (mW)	Output Power (dBm)
5250~5350	26.610	14.25
5470~5725	74.513	18.72

Note: Manufacturer provides Transmit Power Control description to meet this requirement.

4.5 Peak Power Spectral Density Measurement

4.5.1 Limits of Peak Power Spectral Density Measurement

Operation Band	EUT Category		LIMIT
U-NII-1	-	Outdoor Wi-Fi & BLE Array AP	17dBm/ MHz
	-	Fixed point-to-point Wi-Fi & BLE Array AP	
	-	Indoor Wi-Fi & BLE Array AP	
	-	Mobile and Portable client device	11dBm/ MHz
U-NII-2A	√		11dBm/ MHz
U-NII-2C	√		11dBm/ MHz
U-NII-3	√		30dBm/ 500kHz

4.5.2 Test Setup

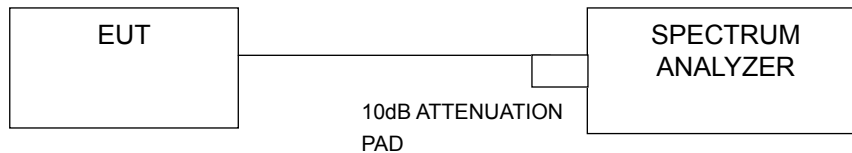

4.5.3 Test Instruments

Refer to section 4.1.2 to get information of above instrument.

4.5.4 Test Procedures

Using method SA-1

- 1) Set span to encompass the entire emission bandwidth (EBW) of the signal.
- 2) Set RBW = 30 kHz, Set VBW ≥ 1 MHz, Detector = RMS
- 3) Set Channel power measure = 1MHz
- 4) Sweep time = auto, trigger set to “free run”.
- 5) Trace average at least 100 traces in power averaging mode.
- 6) Record the max value

Using method SA-2

- 1) Set span to encompass the entire emission bandwidth (EBW) of the signal.
- 2) Set RBW = 30 kHz, Set VBW ≥ 1 MHz, Detector = RMS
- 3) Set Channel power measure = 1MHz
- 4) Sweep time = auto, trigger set to “free run”.
- 5) Trace average at least 100 traces in power averaging mode.
- 6) Record the max value and add 10 log (1/duty cycle)

4.5.5 Deviation from Test Standard

No deviation.

4.5.6 EUT Operating Conditions

Same as Item 4.3.6.

4.5.7 Test Results

802.11a

Chan.	Chan. Freq. (MHz)	PSD (dBm)		Duty Factor	Total Power Density (dBm)	Max. Limit (dBm)	Pass/Fail
		Chain 0	Chain 1				
52	5260	4.40	4.65	0.24	7.77	8.00	Pass
60	5300	4.67	4.46	0.24	7.81	8.00	Pass
64	5320	4.70	4.33	0.24	7.77	8.00	Pass
100	5500	3.64	3.77	0.24	6.95	8.00	Pass
116	5580	4.40	4.57	0.24	7.73	8.00	Pass
140	5700	4.40	4.16	0.24	7.53	8.00	Pass
144 (For U-NII-2C)	5720	4.41	3.99	0.24	7.45	8.00	Pass

- Note: 1. Method 1 of power density measurement of KDB 662911 is using for calculating total power density. Total power density is summing entire spectra across corresponding frequency bins on the various outputs by computer.
2. Directional gain = $10 \log[(10^{G1/20} + 10^{G2/20} + \dots + 10^{GN/20})^2/N]$ = 9dBi > 6dBi, so the power density limit shall be reduced to 11-(9-6) = 8.00dBm.
3. Refer to section 3.3 for duty cycle spectrum plot.

802.11n (HT20)

Chan.	Chan. Freq. (MHz)	PSD (dBm)		Total Power Density (dBm)	Max. Limit (dBm)	Pass/Fail
		Chain 0	Chain 1			
52	5260	4.37	4.16	7.28	8.00	Pass
60	5300	4.75	3.93	7.37	8.00	Pass
64	5320	5.30	4.28	7.83	8.00	Pass
100	5500	4.41	4.53	7.48	8.00	Pass
116	5580	4.25	4.56	7.42	8.00	Pass
140	5700	4.99	3.95	7.51	8.00	Pass
144 (For U-NII-2C)	5720	3.99	3.99	7.00	8.00	Pass

- Note: 1. Method 1 of power density measurement of KDB 662911 is using for calculating total power density. Total power density is summing entire spectra across corresponding frequency bins on the various outputs by computer.
2. Directional gain = $10 \log[(10^{G1/20} + 10^{G2/20} + \dots + 10^{GN/20})^2/N]$ = 9dBi > 6dBi, so the power density limit shall be reduced to 11-(9-6) = 8.00dBm.

802.11n (HT40)

Chan.	Chan. Freq. (MHz)	PSD (dBm)		Duty Factor	Total Power Density (dBm)	Max. Limit (dBm)	Pass/Fail
		Chain 0	Chain 1				
54	5270	3.71	3.99	0.17	7.04	8.00	Pass
62	5310	0.75	0.76	0.17	3.94	8.00	Pass
102	5510	-1.30	-1.02	0.17	2.03	8.00	Pass
110	5550	3.78	3.86	0.17	7.00	8.00	Pass
134	5670	2.74	3.30	0.17	6.21	8.00	Pass
142 (For U-NII-2C)	5710	2.40	3.33	0.17	6.07	8.00	Pass

Note: 1. Method 1 of power density measurement of KDB 662911 is using for calculating total power density. Total power density is summing entire spectra across corresponding frequency bins on the various outputs by computer.

2. Directional gain = $10 \log[(10^{G1/20} + 10^{G2/20} + \dots + 10^{GN/20})^2/N]$ = 9dBi > 6dBi, so the power density limit shall be reduced to 11-(9-6) = 8.00dBm.

3. Refer to section 3.3 for duty cycle spectrum plot.

802.11ac (VHT80)

Chan.	Chan. Freq. (MHz)	PSD (dBm)		Duty Factor	Total Power Density (dBm)	Max. Limit (dBm)	Pass/Fail
		Chain 0	Chain 1				
58	5290	-5.84	-5.17	0.37	-2.11	8.00	Pass
106	5530	-5.18	-4.67	0.37	-1.54	8.00	Pass
138 (For U-NII-2C)	5690	-1.53	-0.61	0.37	2.33	8.00	Pass

Note: 1. Method 1 of power density measurement of KDB 662911 is using for calculating total power density. Total power density is summing entire spectra across corresponding frequency bins on the various outputs by computer.

2. Directional gain = $10 \log[(10^{G1/20} + 10^{G2/20} + \dots + 10^{GN/20})^2/N]$ = 9dBi > 6dBi, so the power density limit shall be reduced to 11-(9-6) = 8.00dBm.

3. Refer to section 3.3 for duty cycle spectrum plot.



Spectrum Plot of Worst Value

802.11a / Chain 0 / Ch 64

802.11n (HT20) / Chain 0 / Ch 64

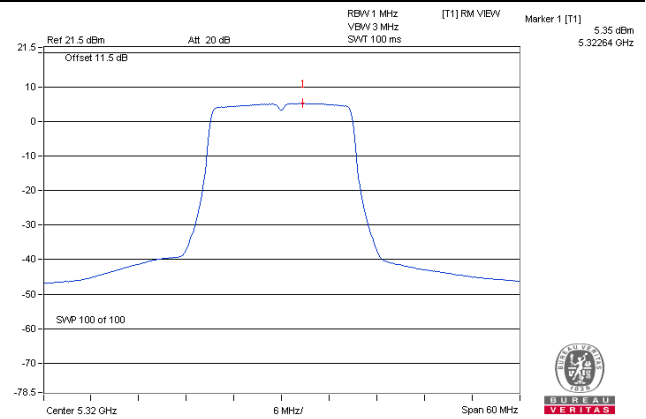
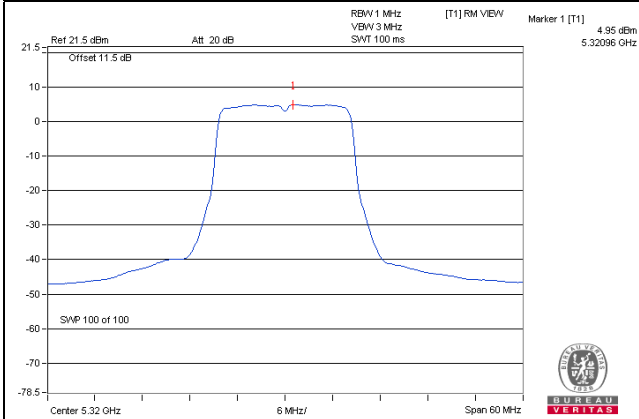

802.11n (HT40) / Chain 1 / Ch 54

802.11ac (VHT80) / Chain 1 / Ch 138

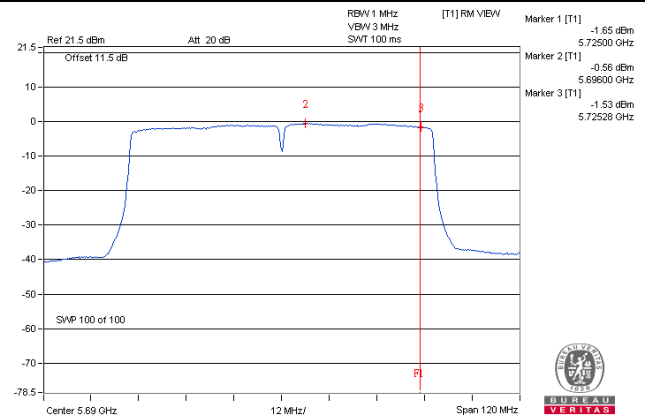
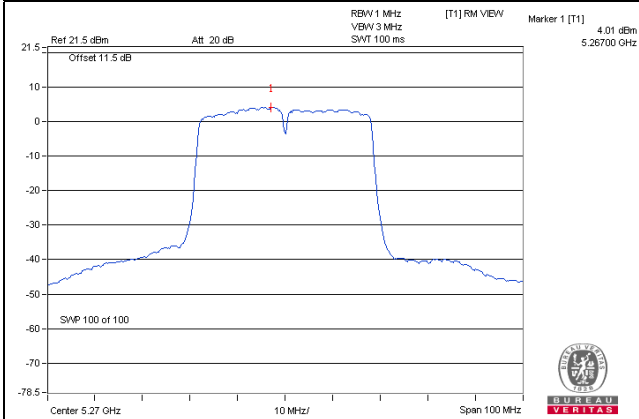

For 5745 ~ 5825MHz

802.11a

TX chain	Chan.	Freq. (MHz)	PSD (dBm/300 kHz)	PSD (dBm/500 kHz)	10 log (N=2) dB	Duty factor	Total PSD (dBm/500 kHz)	Limit (dBm/500 kHz)	Pass / Fail
0	144 (For U-NII-3)	5720	-3.78	-1.56	3.01	0.24	1.69	27.00	Pass
1	144 (For U-NII-3)	5720	-3.60	-1.38	3.01	0.24	1.87	27.00	Pass

Note:

1. Directional gain = $10 \log[(10^{G1/20} + 10^{G2/20} + \dots + 10^{GN/20})^2/2] = 9 \text{ dBi} > 6\text{dBi}$, so the power density limit shall be reduced to $30-(9-6) = 27.00\text{dBm}$.
2. Refer to section 3.3 for duty cycle spectrum plot.

802.11n (HT20)

TX chain	Chan.	Freq. (MHz)	PSD (dBm/300 kHz)	PSD (dBm/500 kHz)	10 log (N=2) dB	Total PSD (dBm/500 kHz)	Limit (dBm/500 kHz)	Pass / Fail
0	144 (For U-NII-3)	5720	-4.17	-1.95	3.01	1.06	27.00	Pass
1	144 (For U-NII-3)	5720	-4.14	-1.92	3.01	1.09	27.00	Pass

Note:

1. Directional gain = $10 \log[(10^{G1/20} + 10^{G2/20} + \dots + 10^{GN/20})^2/2] = 9 \text{ dBi} > 6\text{dBi}$, so the power density limit shall be reduced to $30-(9-6) = 27.00\text{dBm}$.

802.11n (HT40)

TX chain	Chan.	Freq. (MHz)	PSD (dBm/300 kHz)	PSD (dBm/500 kHz)	10 log (N=2) dB	Duty factor	Total PSD (dBm/500 kHz)	Limit (dBm/500 kHz)	Pass / Fail
0	142 (For U-NII-3)	5710	-7.04	-4.82	3.01	0.17	-1.64	27.00	Pass
1	142 (For U-NII-3)	5710	-6.37	-4.15	3.01	0.17	-0.97	27.00	Pass

Note:

1. Directional gain = $10 \log[(10^{G1/20} + 10^{G2/20} + \dots + 10^{GN/20})^2/2] = 9 \text{ dBi} > 6\text{dBi}$, so the power density limit shall be reduced to $30-(9-6) = 27.00\text{dBm}$.
2. Refer to section 3.3 for duty cycle spectrum plot.



802.11ac (VHT80)

TX chain	Chan.	Freq. (MHz)	PSD (dBm/300 kHz)	PSD (dBm/500 kHz)	10 log (N=2) dB	Duty factor	Total PSD (dBm/500 kHz)	Limit (dBm/500 kHz)	Pass / Fail
0	138 (For U-NII-3)	5690	-10.46	-8.24	3.01	0.37	-4.86	27.00	Pass
1	138 (For U-NII-3)	5690	-9.90	-7.68	3.01	0.37	-4.30	27.00	Pass

Note:

- Directional gain = $10 \log[(10^{G1/20} + 10^{G2/20} + \dots + 10^{GN/20})^2/2] = 8.87 \text{ dBi} > 6 \text{ dBi}$, so the power density limit shall be reduced to $30 - (8.87 - 6) = 27.13 \text{ dBm}$.
- Refer to section 3.3 for duty cycle spectrum plot.

Spectrum Plot of Worst Value

802.11a

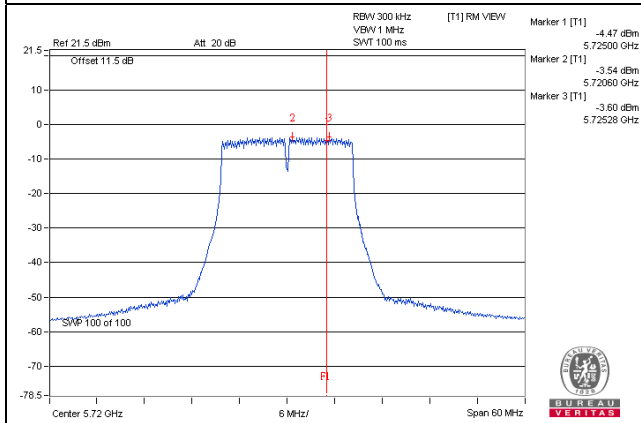

802.11n (HT20)

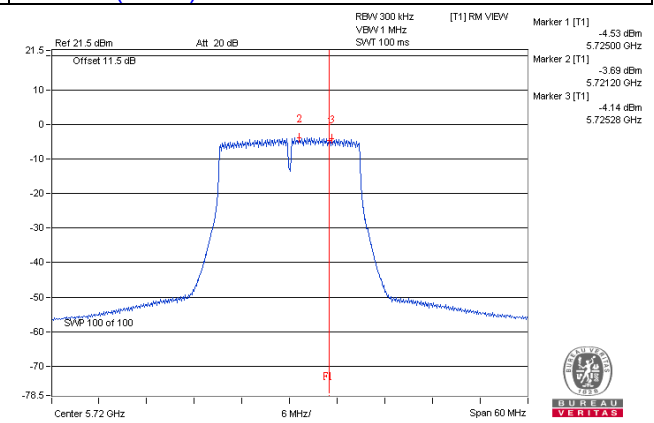

802.11n (HT40)

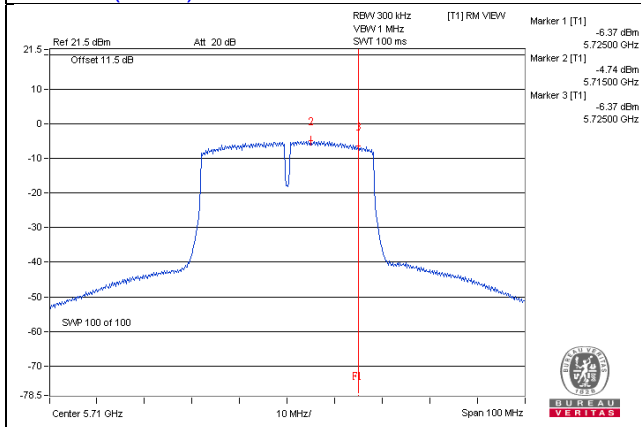

802.11ac (VHT80)

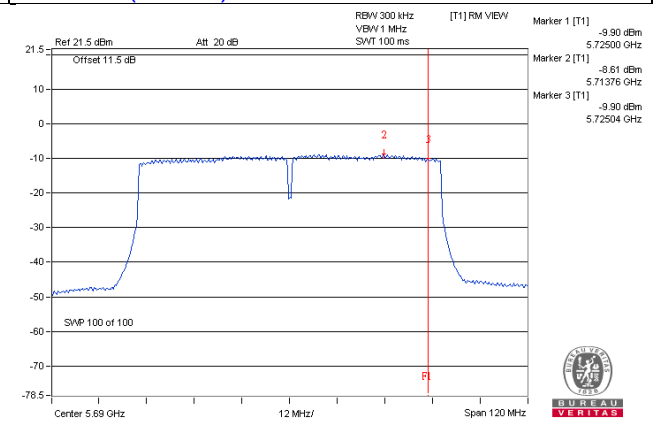

4.6 Frequency Stability

4.6.1 Limits of Frequency Stability Measurement

The frequency of the carrier signal shall be maintained within band of operation

4.6.2 Test Setup

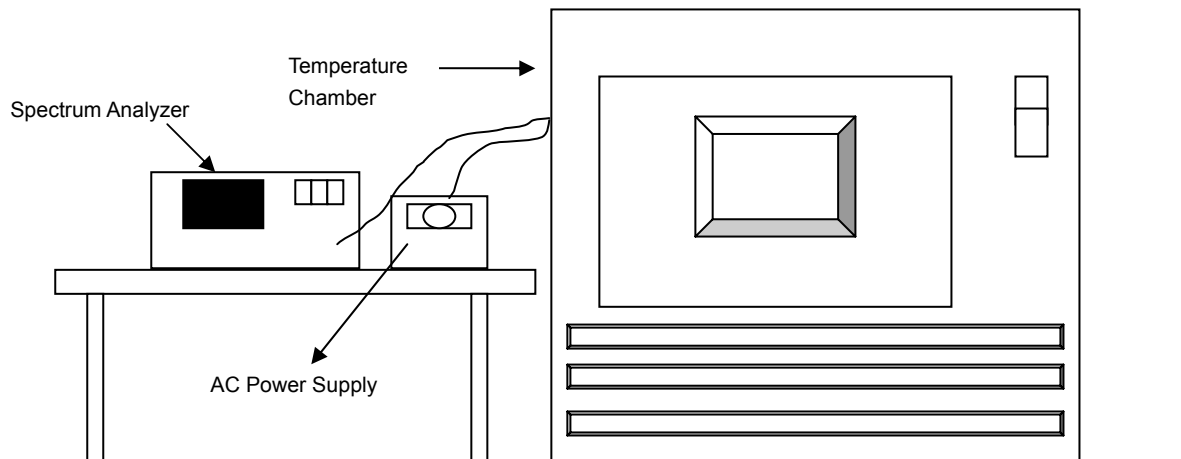

4.6.3 Test Instruments

Refer to section 4.1.2 to get information of above instrument.

4.6.4 Test Procedure

- The EUT was placed inside the environmental test chamber and powered by nominal AC voltage.
- Turn the EUT on and couple its output to a spectrum analyzer.
- Turn the EUT off and set the chamber to the highest temperature specified.
- Allow sufficient time (approximately 30 min) for the temperature of the chamber to stabilize, turn the EUT on and measure the operating frequency after 2, 5, and 10 minutes.
- Repeat step 2 and 3 with the temperature chamber set to the lowest temperature.
- The test chamber was allowed to stabilize at +20 degree C for a minimum of 30 minutes. The supply voltage was then adjusted on the EUT from 85% to 115% and the frequency record.

4.6.5 Deviation from Test Standard

No deviation.

4.6.6 EUT Operating Condition

Set the EUT transmit at un-modulation mode to test frequency stability.

4.6.7 Test Results

Frequency Stability Versus Temp.									
Operating Frequency: 5260MHz									
Temp. (°C)	Power Supply (Vac)	0 Minute		2 Minute		5 Minute		10 Minute	
		Measured Frequency (MHz)	Pass/Fail	Measured Frequency (MHz)	Pass/Fail	Measured Frequency (MHz)	Pass/Fail	Measured Frequency (MHz)	Pass/Fail
50	120	5260.0057	Pass	5260.0042	Pass	5260.0053	Pass	5260.0068	Pass
40	120	5259.9837	Pass	5259.9866	Pass	5259.9870	Pass	5259.9857	Pass
30	120	5260.0130	Pass	5260.0110	Pass	5260.0137	Pass	5260.0124	Pass
20	120	5259.9746	Pass	5259.9741	Pass	5259.9736	Pass	5259.9738	Pass
10	120	5260.0180	Pass	5260.0157	Pass	5260.0163	Pass	5260.0176	Pass
0	120	5259.9913	Pass	5259.9912	Pass	5259.9915	Pass	5259.9922	Pass
-10	120	5260.0008	Pass	5260.0016	Pass	5260.0024	Pass	5260.0029	Pass
-20	120	5259.9948	Pass	5259.9962	Pass	5259.9967	Pass	5259.9948	Pass
-30	120	5260.0075	Pass	5260.0045	Pass	5260.0070	Pass	5260.0085	Pass

Frequency Stability Versus Voltage									
Operating Frequency: 5260MHz									
Temp. (°C)	Power Supply (Vac)	0 Minute		2 Minute		5 Minute		10 Minute	
		Measured Frequency (MHz)	Pass/Fail	Measured Frequency (MHz)	Pass/Fail	Measured Frequency (MHz)	Pass/Fail	Measured Frequency (MHz)	Pass/Fail
20	138	5259.9755	Pass	5259.9748	Pass	5259.9734	Pass	5259.9748	Pass
	120	5259.9746	Pass	5259.9741	Pass	5259.9736	Pass	5259.9738	Pass
	102	5259.9736	Pass	5259.9750	Pass	5259.9728	Pass	5259.9738	Pass

4.7 6dB Bandwidth Measurement

4.7.1 Limits of 6dB Bandwidth Measurement

The minimum of 6dB Bandwidth Measurement is 0.5MHz.

4.7.2 Test Setup

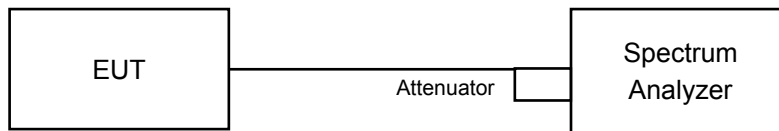

4.7.3 Test Instruments

Refer to section 4.1.2 to get information of above instrument.

4.7.4 Test Procedure

Measurement Procedure REF

- Set resolution bandwidth (RBW) = 100kHz
- Set the video bandwidth (VBW) $\geq 3 \times$ RBW, Detector = Peak.
- Trace mode = max hold.
- Sweep = auto couple.
- Measure the maximum width of the emission that is constrained by the frequencies associated with the two amplitude points (upper and lower) that are attenuated by 6 dB relative to the maximum level measured in the fundamental emission

4.7.5 Deviation from Test Standard

No deviation.

4.7.6 EUT Operating Condition

The software provided by client to enable the EUT under transmission condition continuously at lowest, middle and highest channel frequencies individually.

4.7.7 Test Results

802.11a

Chan.	Freq. (MHz)	6dB Bandwidth (MHz)		Minimum Limit (MHz)	Pass / Fail
		Chain 0	Chain 1		
144 (For U-NII-3)	5720	3.17	3.17	0.5	Pass

802.11n (HT20)

Chan.	Freq. (MHz)	6dB Bandwidth (MHz)		Minimum Limit (MHz)	Pass / Fail
		Chain 0	Chain 1		
144 (For U-NII-3)	5720	3.78	3.79	0.5	Pass

802.11n (HT40)

Chan.	Freq. (MHz)	6dB Bandwidth (MHz)		Minimum Limit (MHz)	Pass / Fail
		Chain 0	Chain 1		
142 (For U-NII-3)	5710	3.20	3.16	0.5	Pass

802.11ac (VHT80)

Chan.	Freq. (MHz)	6dB Bandwidth (MHz)		Minimum Limit (MHz)	Pass / Fail
		Chain 0	Chain 1		
138 (For U-NII-3)	5690	2.87	3.21	0.5	Pass

Spectrum Plot of Worst Value

802.11a

802.11n (HT20)

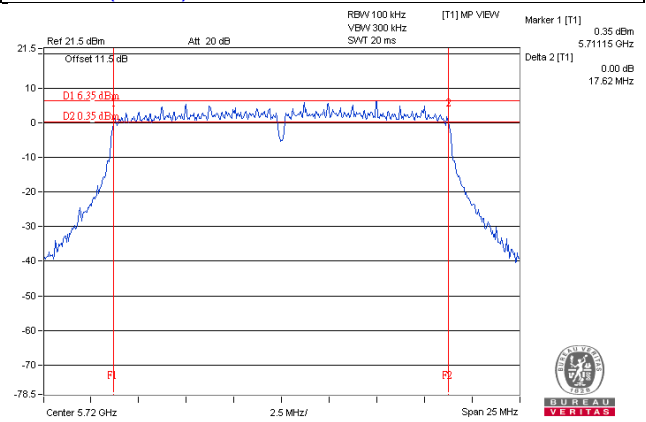
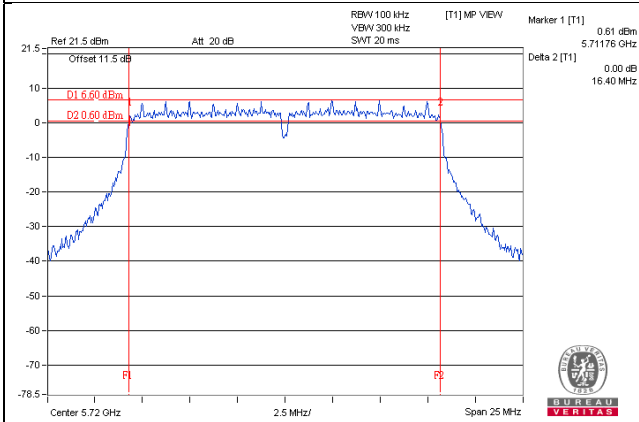

802.11n (HT40)

802.11ac (VHT80)

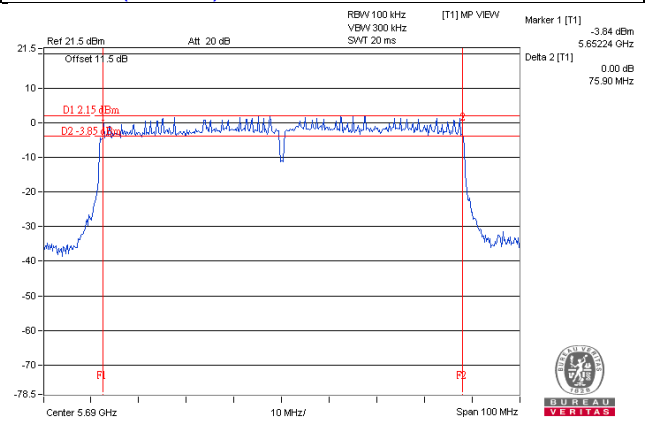
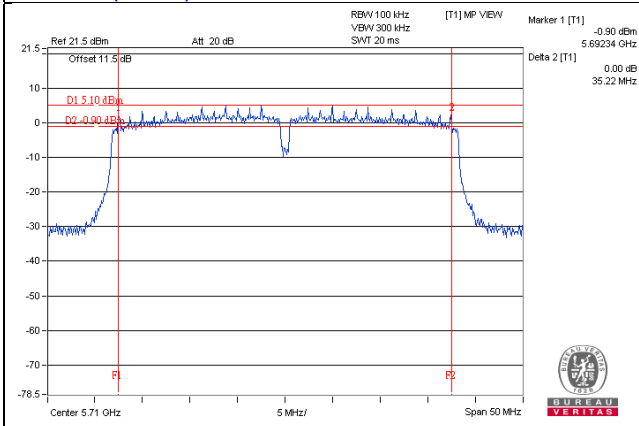

Note:

For CH144 (UNII-3 Band): The 6dB bandwidth above 5725MHz = Marker 1 + Delta 2 - 5725MHz

For CH142 (UNII-3 Band): The 6dB bandwidth above 5725MHz = Marker 1 + Delta 2 - 5725MHz

For CH138 (UNII-3 Band): The 6dB bandwidth above 5725MHz = Marker 1 + Delta 2 - 5725MHz

5 Pictures of Test Arrangements

Please refer to the attached file (Test Setup Photo).

Appendix – Information on the Testing Laboratories

We, Bureau Veritas Consumer Products Services (H.K.) Ltd., Taoyuan Branch, were founded in 1988 to provide our best service in EMC, Radio, Telecom and Safety consultation. Our laboratories are FCC recognized accredited test firms and accredited and approved according to ISO/IEC 17025.

If you have any comments, please feel free to contact us at the following:

Linko EMC/RF Lab

Tel: 886-2-26052180

Fax: 886-2-26051924

Hsin Chu EMC/RF/Telecom Lab

Tel: 886-3-6668565

Fax: 886-3-6668323

Hwa Ya EMC/RF/Safety

Tel: 886-3-3183232

Fax: 886-3-3270892

Email: service.adt@tw.bureauveritas.com

Web Site: www.bureauveritas-adt.com

The address and road map of all our labs can be found in our web site also.

--- END ---