



Test Report

FCC ID: 2AKCY-0550000716
IC: 4706A-0550000716

FCC Rule Part: 15.247
ISED Canada Radio Standards Specification: RSS-247

Report Number: AT72161430-2C1

Manufacturer: COOPER LIGHTING LLC
Model: 0550-000716

Test Begin Date: July 15, 2020
Test End Date: March 18, 2021

Report Issue Date: May 13, 2021



FOR THE SCOPE OF ACCREDITATION UNDER Certificate Number: 2955.09

This report must not be used by the client to claim product certification, approval, or endorsement by A2LA, NIST, or any agency of the Federal Government.

Prepared By:

Divya Adusumilli
Senior Wireless Engineer

TÜV SÜD America Inc.

Reviewed by:

Kirby Munroe
Wireless / EMC Technical and
Certification Manager, NA
TÜV SÜD America Inc.

This test report shall not be reproduced except in full. This report may be reproduced in part with prior written consent of TÜV SÜD America Inc. The results contained in this report are representative of the sample(s) submitted for evaluation.

This report contains 41 pages

TABLE OF CONTENTS

1	GENERAL	3
1.1	PURPOSE	3
1.2	APPLICANT INFORMATION	3
1.3	PRODUCT DESCRIPTION	3
1.4	TEST METHODOLOGY AND CONSIDERATIONS	3
2	TEST FACILITIES	4
2.1	LOCATION	4
2.2	LABORATORY ACCREDITATIONS/RECOGNITIONS/CERTIFICATIONS	4
2.3	RADIATED EMISSIONS TEST SITE DESCRIPTION	5
2.3.1	<i>Semi-Anechoic Chamber Test Site – Chamber A</i>	5
2.3.2	<i>Semi-Anechoic Chamber Test Site – Chamber B</i>	6
2.4	CONDUCTED EMISSIONS TEST SITE DESCRIPTION	7
2.4.1	<i>Conducted Emissions Test Site</i>	7
3	APPLICABLE STANDARD REFERENCES	8
4	LIST OF TEST EQUIPMENT	8
5	SUPPORT EQUIPMENT	9
6	EQUIPMENT UNDER TEST SETUP BLOCK DIAGRAM	9
7	SUMMARY OF TESTS	10
7.1	ANTENNA REQUIREMENT – FCC: 15.203	10
7.2	POWER LINE CONDUCTED EMISSIONS – FCC: 15.207, ISED CANADA: RSS-GEN 8.8	10
7.2.1	<i>Measurement Procedure</i>	10
7.2.2	<i>Measurement Results</i>	10
7.3	6dB / 99% BANDWIDTH – FCC: 15.247(A)(2), ISED CANADA: RSS-247 5.2(A), RSS-GEN 6.7.12	12
7.3.1	<i>Measurement Procedure</i>	12
7.3.2	<i>Measurement Results</i>	12
7.4	FUNDAMENTAL EMISSION OUTPUT POWER – FCC: 15.247(B)(3), ISED CANADA: RSS-247 5.4(D)	21
7.4.1	<i>Measurement Procedure</i>	21
7.4.2	<i>Measurement Results</i>	21
7.5	EMISSION LEVELS	25
7.5.1	<i>Emissions into Non-restricted Frequency Bands – FCC: 15.247(d); ISED Canada: RSS-247 5.5</i>	25
7.5.2	<i>Emissions into Restricted Frequency Bands – FCC: 15.205, 15.209; ISED Canada: RSS-Gen 8.9 / 8.10</i>	28
7.6	MAXIMUM POWER SPECTRAL DENSITY IN THE FUNDAMENTAL EMISSION – FCC: 15.247(E) ISED CANADA: RSS-247 5.2(B)	29
7.6.1	<i>Measurement Procedure</i>	29
7.6.2	<i>Measurement Results</i>	29
8	ESTIMATION OF MEASUREMENT UNCERTAINTY	34
9	CONCLUSION	34
	APPENDIX A: PLOTS	35

1 GENERAL

1.1 Purpose

The purpose of this report is to demonstrate compliance with Part 15 Subpart C of the FCC's Code of Federal Regulations and Innovation, Science and Economic Development Canada's Radio Standards Specification RSS-247 for the tests documented herein.

1.2 Applicant Information

Cooper Lighting LLC.
NAFSC-1030
PO BOX 818044
CLEVELAND, OH 44181-8044

1.3 Product Description

Wave Linx Econ Sensor Integrated, single Chip, (model 0550-000716) will be used as part of light fixture for occupancy detention, ambient light sensor and controlling light over wireless network.

Technical Details:

Detail	Description
Frequency Range (MHz)	2405 – 2480
Number of Channels	16
Channel Spacing	5 MHz
Modulation Format	O-QPSK
Data Rates	250kbps
Operating Voltage	12-24 Vdc
Antenna Type(s) / Gain(s)	Isolated Magnetic Dipole/ 2.6dBi

Test Sample Serial Number(s): Not Labeled

Test Sample Condition: The equipment was provided in good condition without any physical damage.

1.4 Test Methodology and Considerations

All modes of operation, including all data rates, were evaluated and the data presented in this report represents the worst case where applicable.

For radiated emissions, the EUT was evaluated in three orthogonal orientations. The worst-case orientation was the X-orientation.

For antenna port conducted emissions, an SMA pigtail was used to directly connect the DUT to the measuring equipment through suitable attenuation.

For AC Power Line Conducted emissions measurements, the EuT was connected to a representative LED Driver Power Supply.

Power setting during test: CH11-CH25 :12.7 dBm & CH26: 0.0 dBm

2 TEST FACILITIES

2.1 Location

The radiated and conducted emissions test sites are located at the following addresses:

TÜV SÜD America, Inc.
5945 Cabot Pkwy, Suite 100
Alpharetta, GA 30005
Phone: (678) 341-5900

2.2 Laboratory Accreditations/Recognitions/Certifications

TÜV SÜD America, Inc. is accredited to ISO/IEC 17025 by the American Association for Laboratory Accreditation/A2LA accreditation program and has been issued certificate number 2955.09 in recognition of this accreditation.

Unless otherwise specified, all tests methods described within this report are covered under the ISO/IEC 17025 scopes of accreditation.

The Semi-Anechoic Chamber Test Sites and Conducted Emissions Sites have been fully described, submitted to, and accepted by the FCC, ISED Canada and the Japanese Voluntary Control Council for Interference by information technology equipment.

FCC Designation Accreditation Number: US1233
ISED Canada Lab Code: 23932
VCCI Member Number: 1831
• VCCI Registration Number A-0295

2.3 Radiated Emissions Test Site Description

2.3.1 Semi-Anechoic Chamber Test Site – Chamber A

The Semi-Anechoic Chamber Test Site consists of a 20' x 30' x 18' shielded enclosure. The chamber is lined with Toyo Ferrite Grid Absorber, model number FFG-1000. The ferrite tile grid is 101 x 101 x 19mm thick and weighs approximately 550 grams. These tiles are mounted on steel panels and installed directly on the inner walls of the chamber.

The turntable is 5' in diameter and is located 5'6" from the back wall of the chamber. The chamber is grounded via 1 - 8' copper ground rod, installed at the center of the back wall, it is bound to the ground plane using 3/4" stainless steel braided cable.

The turntable is all steel, flush mounted EMCO Model 1060 installed in an all steel frame. The table is remotely operated from inside the control room located 25' from the range. The turntable is electrically bonded to the surrounding ground plane via steel fingers installed on the edge of the turn table. The steel fingers make constant contact with the ground plane during operation.

Behind the turntable is a 3' x 6' x 4' deep shielded pit used for support equipment if necessary. The pit is equipped with 1 - 4" PVC chase from the turntable to the pit that allows for cabling to the EUT if necessary. The underside of the turntable can be accessed from the pit so cables can be supplied to the EUT from the pit.

The chamber rear wall is covered with a mixture of Siepel pyramidal absorber. The side walls of the chamber are partially covered with Siepel pyramidal absorber.

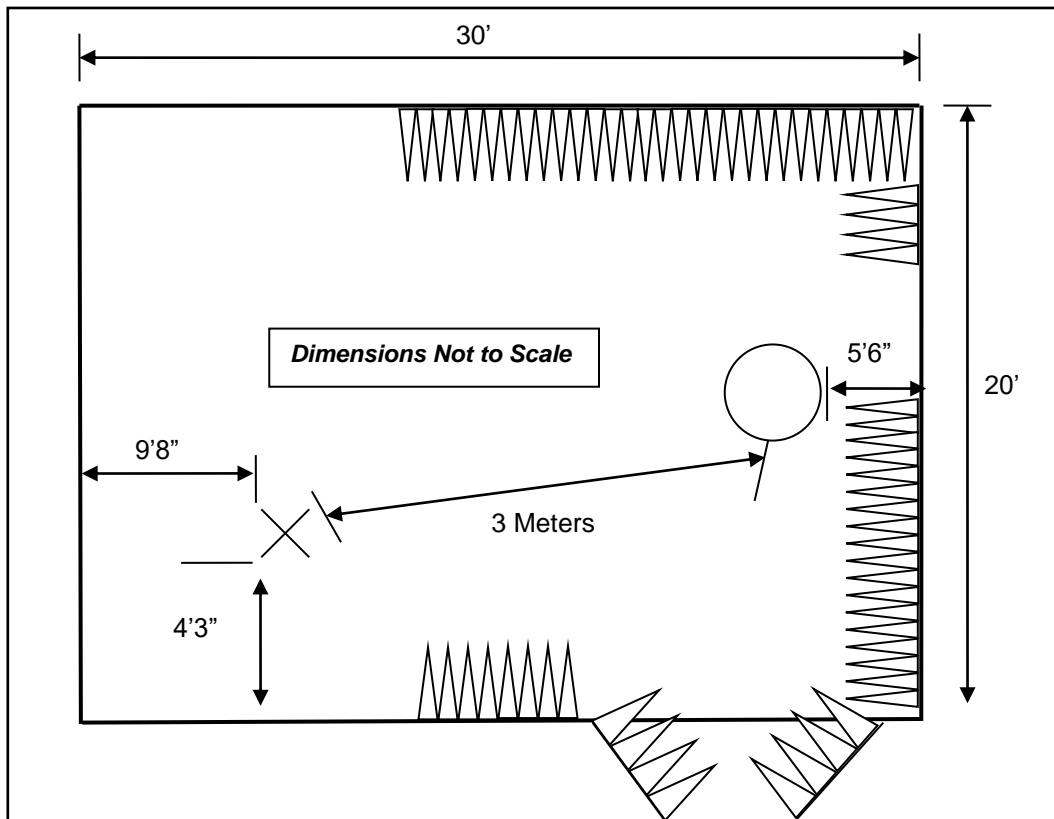

Figure 2.3.1-1: Semi-Anechoic Chamber Test Site – Chamber A

2.3.2 Semi-Anechoic Chamber Test Site – Chamber B

The Semi-Anechoic Chamber Test Site consists of a 20'W x 30'L x 20'H shielded enclosure. The chamber is lined with ETS-Lindgren Ferrite Absorber, model number FT-1500. The ferrite tile 600 mm x 600 mm (2.62 in x 23.62 in) panels and are mounted directly on the inner walls of the chamber shield.

The specular regions of the chamber are lined with additional ETS-Lindgren PS-600 hybrid absorber to extend its frequency range up to 18GHz and beyond.

The turntable is a 2m ETS-Lindgren Model 2170 and installed off the center axis is located 5'6" from the back wall of the chamber. The chamber is grounded via 1 - 8' copper ground rod, installed at the center of the back wall, it is bound to the shield using #8 solid copper wire.

The antenna mast is an EMCO 1060 and is remotely controlled from the control room for both antenna height and polarization.

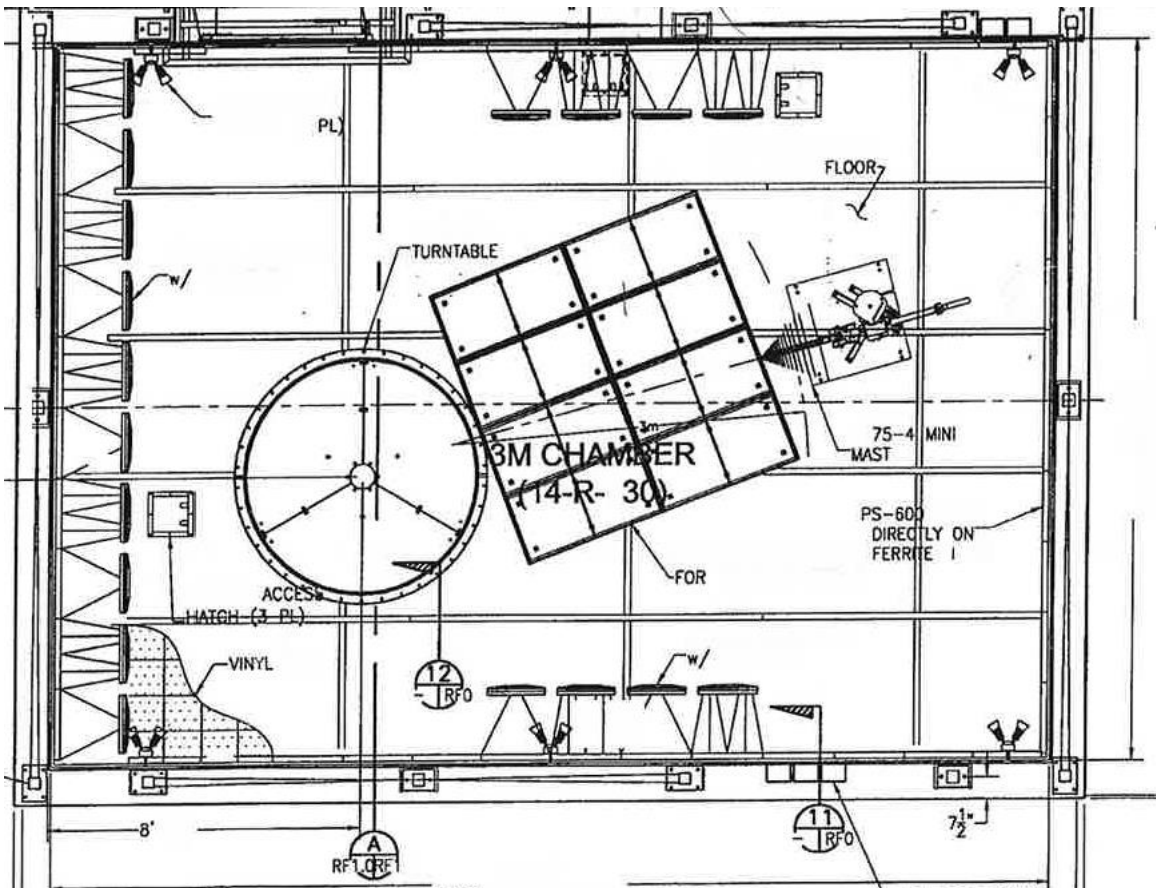

Figure 2.3.2-1: Semi-Anechoic Chamber Test Site – Chamber B

2.4 Conducted Emissions Test Site Description

2.4.1 Conducted Emissions Test Site

The AC mains conducted EMI site is located in the main EMC lab. It consists of a 12' x 10' horizontal coupling plane (HCP) as well as a 12'x8' vertical coupling plane (VCP). The HGP is constructed of 4' x 10' sheets of particle board sandwiched by galvanized steel sheets. These panels are bonded using 11AWG 1/8" x 2" by 10' galvanized sheet steel secured to the panels via by screws. The VCP is constructed of three 4'x8' sheets of 11AWG solid aluminum.

The HCP and VCP are electrically bonded together using 1"x1" angled aluminum secured with screws.

The site is of sufficient size to test tabletop and floor standing equipment in accordance with section 6.1.4 of ANSI C63.10.

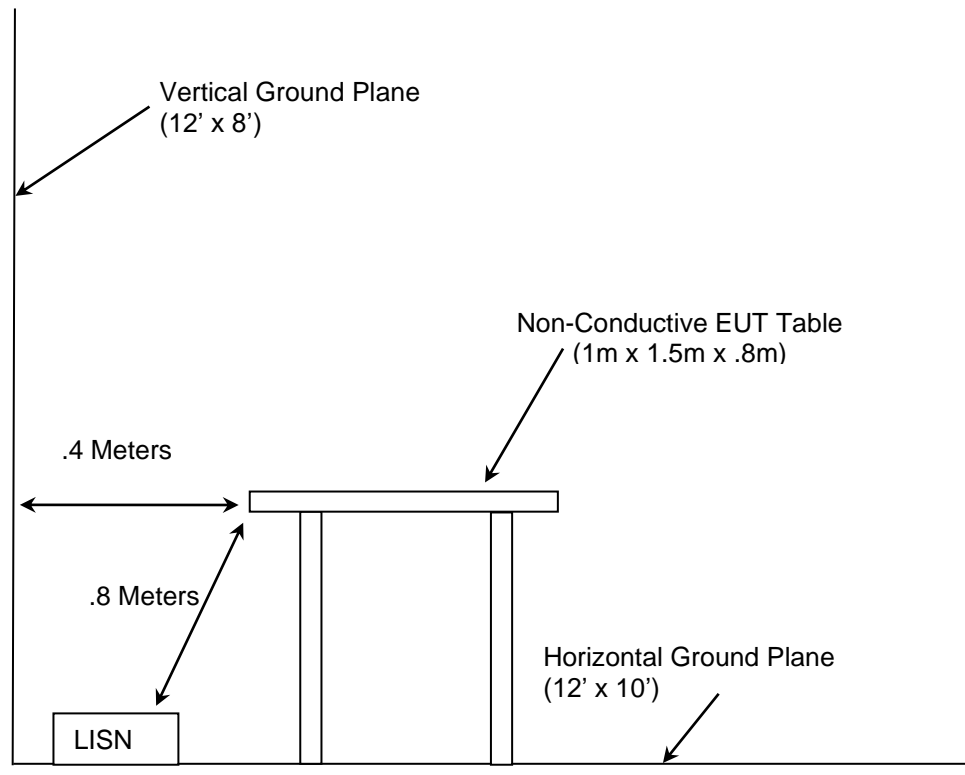

Figure 2.4.1-1: AC Mains Conducted EMI Site

3 APPLICABLE STANDARD REFERENCES

The following standards were used:

- ❖ ANSI C63.10-2013: American National Standard of Procedures for Compliance Testing of Unlicensed Wireless Devices.
- ❖ US Code of Federal Regulations (CFR): Title 47, Part 2, Subpart J: Equipment Authorization Procedures, 2020
- ❖ US Code of Federal Regulations (CFR): Title 47, Part 15, Subpart C: Radio Frequency Devices, Intentional Radiators, 2020
- ❖ FCC KDB 558074 D01 15.247 Meas Guidance v05r02 – Guidance for Compliance Measurements on Digital Transmission System, Frequency Hopping Spread Spectrum System, and Hybrid System Devices Operating Under Section 15.247 of the FCC Rules, April 2, 2019
- ❖ ISED Canada Radio Standards Specification: RSS-247 – Digital Transmission Systems (DTSS), Frequency Hopping Systems (FHSs) and License-Exempt Local Area Network (LE-LAN) Devices, Issue 2, February 2017.
- ❖ ISED Canada Radio Standards Specification: RSS-GEN – General Requirements for Compliance of Radio Apparatus, Issue 5, Amendment 1 (March 2019), Amendment 2 (February 2021)

4 LIST OF TEST EQUIPMENT

The calibration interval of test equipment is annually or the manufacturer's recommendations. Where the calibration interval deviates from the annual cycle based on the instrument manufacturer's recommendations, it shall be stated below.

Table 4-1: Test Equipment

Asset ID	Manufacturer	Model	Equipment Type	Serial Number	Last Calibration Date	Calibration Due Date
168	Hewlett Packard	11947A	Transient Pulse Limiter	44829	03/03/2021	03/03/2022
861	Com-Power Corporation	LI-1100C	Line Impedance Stabilization Network	20180038	02/26/2021	02/26/2022
862	Com-Power Corporation	LI01100C	Line Impedance Stabilization Network	20180039	02/26/2021	02/26/2022
813	PMM	9010	EMI Receiver; RF Input 50ohm; 10Hz-50MHz; 10Hz-30MHz	697WW30606	03/03/2020	06/03/2021
871	TUV SUD	RF Cable	RF Cable(CE Cable)	871	04/23/2020	04/23/2021
494	Omega	iBTHX-W	Environmental Sensor	9460211	11/03/2020	11/03/2021
827	TUV SUD	TS8997 Rack Cable Set	TS8997 Rack Cable Set	N/A	09/04/2020	09/04/2021
638	Rohde & Schwarz	OSP 120	Open Switch and Control Unit	101229	06/11/2019	06/11/2021
622	Rohde & Schwarz	FSV40 (v3.40)	FSV Signal Analyzer 10Hz to 40GHz	101338	08/24/2020	08/24/2021
432	Microwave Circuits	H3G020G4	Highpass Filter	264066	06/09/2020	06/09/2021
22	Hewlett Packard	8449B	High Frequency Pre-Amp	3008A00526	10/19/2020	10/19/2021
628	EMCO	6502	Active Loop Antenna 10kHz-30MHz	9407-2877	02/11/2019	05/11/2021
422	Florida RF	SMS-200AW-72.0-SMR	Cable	805	11/27/2017	11/27/2018
335	Suhner	SF-102A	Cable (40GHZ)	882/2A	06/23/2020	06/23/2021
345	Suhner Sucoflex	102A	Cable 42(GHZ)	1077/2A	06/23/2020	06/23/2021
882	Rohde & Schwarz	ESW44	ESW44 EMI TEST RECEIVER	101961	07/28/2020	07/28/2021
857	ETS Lindgren	3117	Horn Antenna 1-18GHz	00153608	11/12/2019	11/12/2021
3161	Teseq; Huber+Suhner	CBL 6112D;6804-17-A	Bilog Antenna; Attenuator	51323; 01252019A	3/19/2021	3/19/2022
334	Rohde & Schwarz	3160-09	HF 18 - 26.5GHz	49404	NCR	NCR

NCR = No Calibration Required

NOTE: All test equipment was used only during active calibration cycles as reported above.

5 SUPPORT EQUIPMENT

Table 5-1: Support Equipment

Item	Equipment Type	Manufacturer	Model Number	Serial Number
1	Sensor Module	Eaton Cooper Lighting	0550-000716	Not Labeled
2	LED Electronic Driver Power Supply	Eaton Cooper Lighting	X1040C110V054PST2	1934734JTJ78367
3	3W Constant Voltage LED Driver Power Supply	XenerQi	XEL-003CBU-V012XB-NNA01P	XELAA2501929000162

Note: 1. Item 2 is used for RF Conducted and Radiated Emissions Test.
2. Item 3 is used for Power Line Conducted Emissions Test.

Table 5-2: Cable Description

Item	Cable Type	Length	Shield
A	AC Power Cord	100 cm	No
B	DC Power Cable	50 cm	Yes

6 EQUIPMENT UNDER TEST SETUP BLOCK DIAGRAM

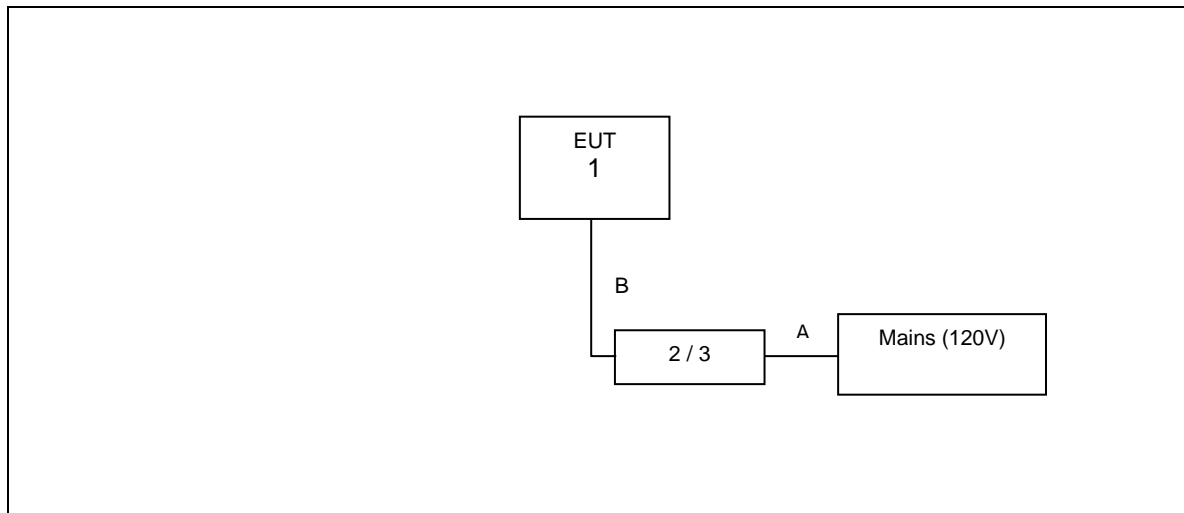

Figure 6-1: Test Setup Block Diagram

7 SUMMARY OF TESTS

Along with the tabular data shown below, plots were taken of all signals deemed important enough to document.

7.1 Antenna Requirement – FCC: 15.203

The EUT utilizes Isolated Magnetic Dipole Antenna which is internal to the enclosure and affixed to the PCB via a UFL cable.

7.2 Power Line Conducted Emissions – FCC: 15.207, ISED Canada: RSS-Gen 8.8

7.2.1 Measurement Procedure

Conducted emissions were performed from 150kHz to 30MHz with the spectrum analyzer's resolution bandwidth set to 9kHz and the video bandwidth set to 30kHz. The calculation for the conducted emissions is as follows:

Corrected Reading = Analyzer Reading + LISN Loss + Cable Loss

Margin = Corrected Reading - Applicable Limit

7.2.2 Measurement Results

Performed by:

Table 7.2.2-1: Conducted EMI Results – 120VAC/60Hz – Line 1

Frequency (MHz)	Corrected Reading		Limit		Margin		Correction (dB)
	Quasi-Peak	Average	Quasi-Peak	Average	Quasi-Peak	Average	
	(dB μ V)	(dB μ V)	(dB μ V)	(dB μ V)	(dB)	(dB)	
0.15	41.84	31.75	66	56	-24.16	-24.25	10.16
0.158	41.25	26.15	65.57	55.57	-24.32	-29.42	10.15
0.166	39.82	25.62	65.16	55.16	-25.34	-29.54	10.15
0.182	38.57	23.95	64.39	54.39	-25.82	-30.44	10.13
0.198	35.72	23.01	63.69	53.69	-27.97	-30.68	10.12
1.986	25.74	12.22	56	46	-30.26	-33.78	10.07
2.17	25.59	11.07	56	46	-30.41	-34.93	10.07
2.962	25.93	11.3	56	46	-30.07	-34.7	10.08
2.994	24.91	11.31	56	46	-31.09	-34.69	10.08
29.978	22.53	14.19	60	50	-37.47	-35.81	10.21

Table 7.2.2-2: Conducted EMI Results – 120VAC/60Hz – Line 2

Frequency (MHz)	Corrected Reading		Limit		Margin		Correction (dB)
	Quasi-Peak	Average	Quasi-Peak	Average	Quasi-Peak	Average	
	(dB μ V)	(dB μ V)	(dB μ V)	(dB μ V)	(dB)	(dB)	
0.15	42.28	32.02	66	56	-23.72	-23.98	10.21
0.154	41.84	31.43	65.78	55.78	-23.94	-24.35	10.21
0.17	40.87	26.55	64.96	54.96	-24.09	-28.41	10.19
0.186	38.09	26.24	64.21	54.21	-26.12	-27.97	10.17
0.206	35.66	25.88	63.37	53.37	-27.71	-27.49	10.15
0.218	32.74	25.45	62.89	52.89	-30.15	-27.44	10.14
2.838	25.97	11.29	56	46	-30.03	-34.71	10.11
2.93	24.01	11.32	56	46	-31.99	-34.68	10.11
2.99	25.97	11.34	56	46	-30.03	-34.66	10.11
29.978	22.55	14.21	60	50	-37.45	-35.79	10.23

7.3 6dB / 99% Bandwidth – FCC: 15.247(a)(2), ISED Canada: RSS-247 5.2(a), RSS-GEN 6.7

7.3.1 Measurement Procedure

The 6dB bandwidth was measured in accordance with the FCC KDB 558074 D01 Section 8.2 which references Subclause 11.8 of ANSI C63.10. The Resolution Bandwidth (RBW) of the spectrum analyzer was set to 100 kHz. The Video Bandwidth (VBW) was set to ≥ 3 times the RBW. The trace was set to max hold with a peak detector active. The marker-delta function of the spectrum analyzer was utilized to determine the 6dB bandwidth of the emission.

The occupied bandwidth measurement function of the spectrum analyzer was used to measure the 99% bandwidth. The span of the analyzer was set to capture all products of the modulation process, including the emission sidebands. The resolution bandwidth was set from 1% to 5% of the occupied bandwidth and the video bandwidth set to at least 3 times the resolution bandwidth. A peak detector was used.

7.3.2 Measurement Results

Performed by: Divya Adusumilli

Table 7.3.2-1: 6dB / 99% Bandwidth

Modulation	Frequency [MHz]	6dB Bandwidth [MHz]	99% Bandwidth [MHz]
O-QPSK / 250kbps	2405	1.743	2.24
	2440	1.743	2.24
	2475	1.743	2.24
	2480	1.743	2.24

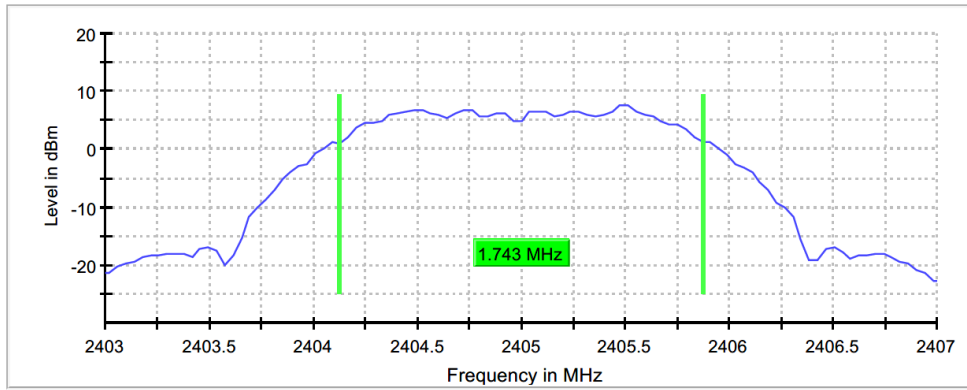

Figure 7.3.2-1: 2405MHz - 6dB BW

Table 7.3.2-2: Measurement Settings (6dB BW)

Setting	Instrument Value	Target Value
Start Frequency	2.40300 GHz	2.40300 GHz
Stop Frequency	2.40700 GHz	2.40700 GHz
Span	4.000 MHz	4.000 MHz
RBW	100.000 kHz	~ 100.000 kHz
VBW	300.000 kHz	~ 300.000 kHz
Sweep Points	101	~ 80
Sweep time	18.938 μ s	AUTO
Reference Level	10.000 dBm	10.000 dBm
Attenuation	30.000 dB	AUTO
Detector	MaxPeak	MaxPeak
Sweep Count	100	100
Filter	3 dB	3 dB
Trace Mode	Max Hold	Max Hold
Sweep type	FFT	AUTO
Preamp	off	off
Stable mode	Trace	Trace
Stable value	0.50 dB	0.50 dB
Run	15 / max. 150	max. 150
Stable	5 / 5	5
Max Stable Difference	0.16 dB	0.50 dB

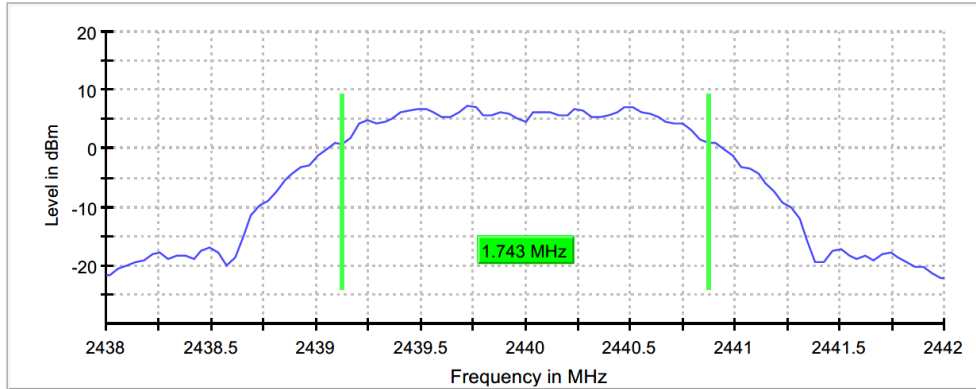

Figure 7.3.2-2: 2440MHz - 6dB BW

Table 7.3.2-3: Measurement Settings (6dB BW)

Setting	Instrument Value	Target Value
Start Frequency	2.43800 GHz	2.43800 GHz
Stop Frequency	2.44200 GHz	2.44200 GHz
Span	4.000 MHz	4.000 MHz
RBW	100.000 kHz	~ 100.000 kHz
VBW	300.000 kHz	~ 300.000 kHz
Sweep Points	101	~ 80
Sweep time	18.938 μ s	AUTO
Reference Level	10.000 dBm	10.000 dBm
Attenuation	30.000 dB	AUTO
Detector	MaxPeak	MaxPeak
Sweep Count	100	100
Filter	3 dB	3 dB
Trace Mode	Max Hold	Max Hold
Sweep type	FFT	AUTO
Preamp	off	off
Stable mode	Trace	Trace
Stable value	0.50 dB	0.50 dB
Run	21 / max. 150	max. 150
Stable	5 / 5	5
Max Stable Difference	0.09 dB	0.50 dB

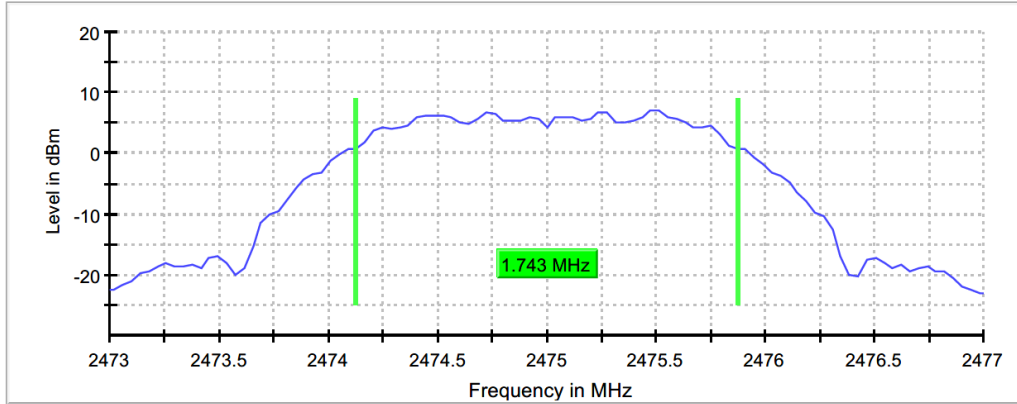

Figure 7.3.2-3: 2475MHz - 6dB BW

Table 7.3.2-4: Measurement Settings (6dB BW)

Setting	Instrument Value	Target Value
Start Frequency	2.47300 GHz	2.47300 GHz
Stop Frequency	2.47700 GHz	2.47700 GHz
Span	4.000 MHz	4.000 MHz
RBW	100.000 kHz	~ 100.000 kHz
VBW	300.000 kHz	~ 300.000 kHz
Sweep Points	101	~ 80
Sweep time	18.938 μ s	AUTO
Reference Level	10.000 dBm	10.000 dBm
Attenuation	30.000 dB	AUTO
Detector	MaxPeak	MaxPeak
Sweep Count	100	100
Filter	3 dB	3 dB
Trace Mode	Max Hold	Max Hold
Sweep type	FFT	AUTO
Preamplifier	off	off
Stable mode	Trace	Trace
Stable value	0.50 dB	0.50 dB
Run	20 / max. 150	max. 150
Stable	5 / 5	5
Max Stable Difference	0.44 dB	0.50 dB

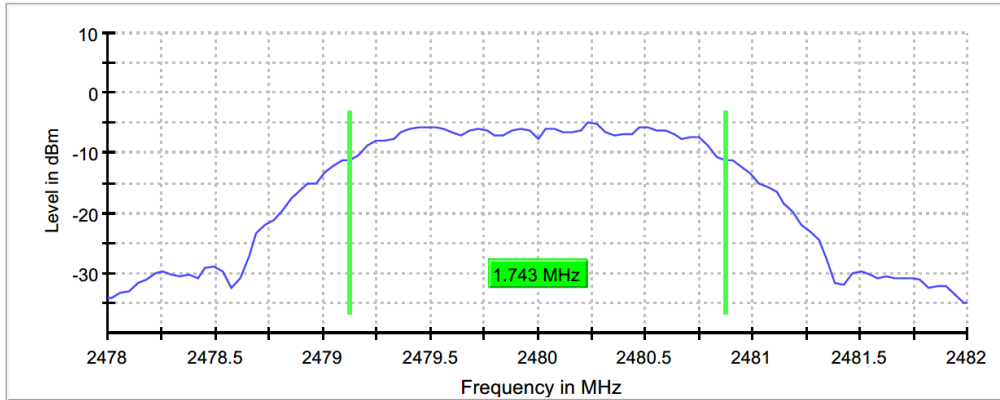

Figure 7.3.2-4: 2480MHz - 6dB BW

Table 7.3.2-5: Measurement Settings (6dB BW)

Setting	Instrument Value	Target Value
Start Frequency	2.47800 GHz	2.47800 GHz
Stop Frequency	2.48200 GHz	2.48200 GHz
Span	4.000 MHz	4.000 MHz
RBW	100.000 kHz	~ 100.000 kHz
VBW	300.000 kHz	~ 300.000 kHz
Sweep Points	101	~ 80
Sweep time	18.938 μ s	AUTO
Reference Level	10.000 dBm	10.000 dBm
Attenuation	30.000 dB	AUTO
Detector	MaxPeak	MaxPeak
Sweep Count	100	100
Filter	3 dB	3 dB
Trace Mode	Max Hold	Max Hold
Sweep type	FFT	AUTO
Preamp	off	off
Stable mode	Trace	Trace
Stable value	0.50 dB	0.50 dB
Run	18 / max. 150	max. 150
Stable	5 / 5	5
Max Stable Difference	0.01 dB	0.50 dB

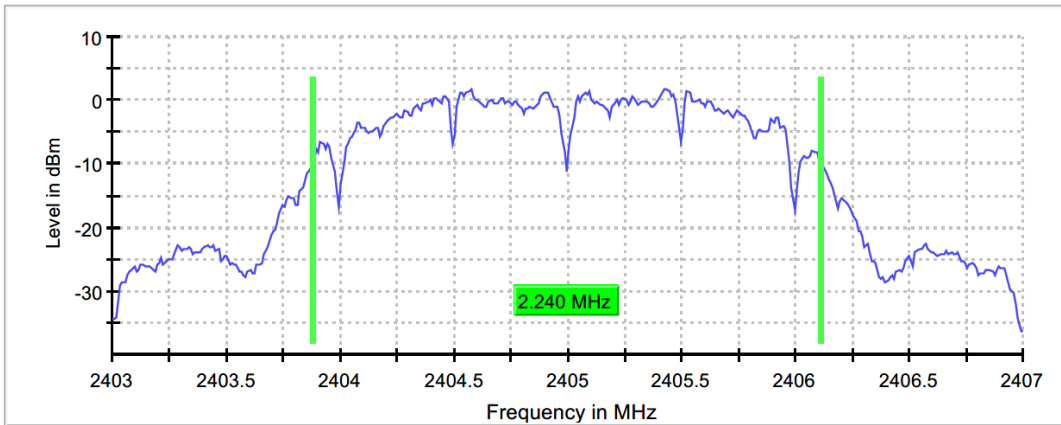

Figure 7.3.2-5: 2405MHz - 99% OBW

Table 7.3.2-6: Measurement Settings (OBW)

Setting	Instrument Value	Target Value
Start Frequency	2.40300 GHz	2.40300 GHz
Stop Frequency	2.40700 GHz	2.40700 GHz
Span	4.000 MHz	4.000 MHz
RBW	20.000 kHz	>= 20.000 kHz
VBW	100.000 kHz	>= 60.000 kHz
Sweep Points	400	~ 400
Sweep time	94.824 μ s	AUTO
Reference Level	10.000 dBm	10.000 dBm
Attenuation	30.000 dB	AUTO
Detector	MaxPeak	MaxPeak
Sweep Count	100	100
Filter	3 dB	3 dB
Trace Mode	Max Hold	Max Hold
Sweep type	FFT	AUTO
Preamp	off	off
Stable mode	Trace	Trace
Stable value	0.30 dB	0.30 dB
Run	19 / max. 150	max. 150
Stable	3 / 3	3
Max Stable Difference	0.13 dB	0.30 dB

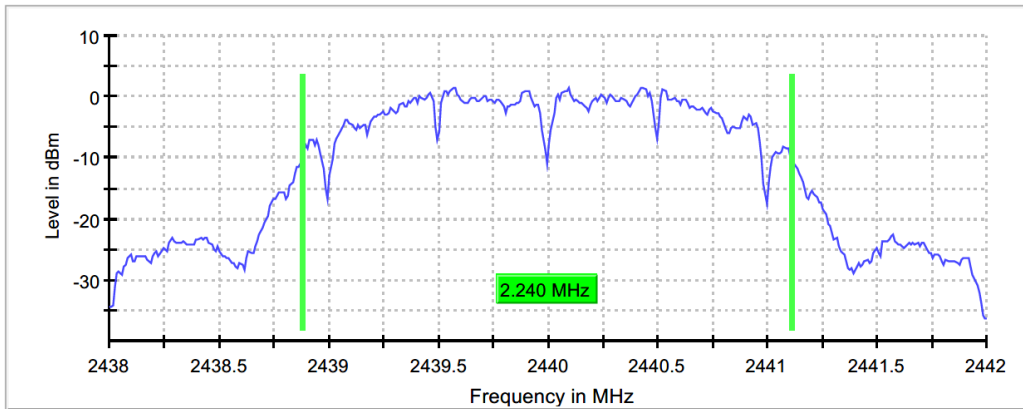

Figure 7.3.2-6: 2440MHz - 99% OBW

Table 7.3.2-7: Measurement Settings (OBW)

Setting	Instrument Value	Target Value
Start Frequency	2.43800 GHz	2.43800 GHz
Stop Frequency	2.44200 GHz	2.44200 GHz
Span	4.000 MHz	4.000 MHz
RBW	20.000 kHz	>= 20.000 kHz
VBW	100.000 kHz	>= 60.000 kHz
Sweep Points	400	~ 400
Sweep time	94.824 μ s	AUTO
Reference Level	10.000 dBm	10.000 dBm
Attenuation	30.000 dB	AUTO
Detector	MaxPeak	MaxPeak
Sweep Count	100	100
Filter	3 dB	3 dB
Trace Mode	Max Hold	Max Hold
Sweep type	FFT	AUTO
Preamp	off	off
Stable mode	Trace	Trace
Stable value	0.30 dB	0.30 dB
Run	28 / max. 150	max. 150
Stable	3 / 3	3
Max Stable Difference	0.21 dB	0.30 dB

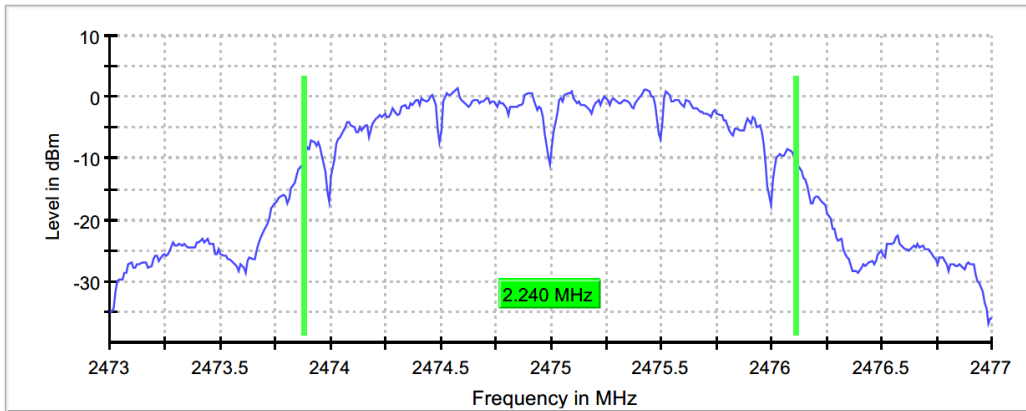

Figure 7.3.2-7: 2475MHz - 99% OBW

Table 7.3.2-8: Measurement Settings (OBW)

Setting	Instrument Value	Target Value
Start Frequency	2.47300 GHz	2.47300 GHz
Stop Frequency	2.47700 GHz	2.47700 GHz
Span	4.000 MHz	4.000 MHz
RBW	20.000 kHz	>= 20.000 kHz
VBW	100.000 kHz	>= 60.000 kHz
Sweep Points	400	~ 400
Sweep time	94.824 μ s	AUTO
Reference Level	10.000 dBm	10.000 dBm
Attenuation	30.000 dB	AUTO
Detector	MaxPeak	MaxPeak
Sweep Count	100	100
Filter	3 dB	3 dB
Trace Mode	Max Hold	Max Hold
Sweep type	FFT	AUTO
Preamp	off	off
Stable mode	Trace	Trace
Stable value	0.30 dB	0.30 dB
Run	27 / max. 150	max. 150
Stable	3 / 3	3
Max Stable Difference	0.00 dB	0.30 dB

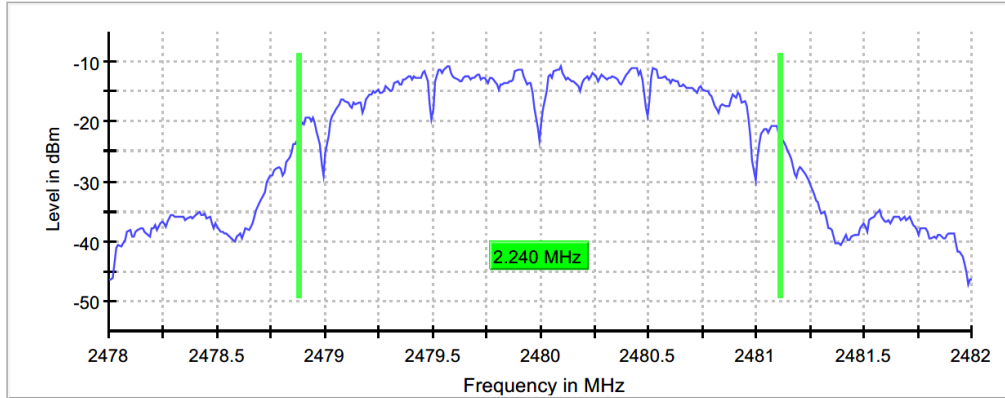

Figure 7.3.2-8: 2480MHz - 99% OBW

Table 7.3.2-9: Measurement Settings (OBW)

Setting	Instrument Value	Target Value
Start Frequency	2.47800 GHz	2.47800 GHz
Stop Frequency	2.48200 GHz	2.48200 GHz
Span	4.000 MHz	4.000 MHz
RBW	20.000 kHz	>= 20.000 kHz
VBW	100.000 kHz	>= 60.000 kHz
Sweep Points	400	~ 400
Sweep time	94.824 μ s	AUTO
Reference Level	10.000 dBm	10.000 dBm
Attenuation	30.000 dB	AUTO
Detector	MaxPeak	MaxPeak
Sweep Count	100	100
Filter	3 dB	3 dB
Trace Mode	Max Hold	Max Hold
Sweep type	FFT	AUTO
Preamp	off	off
Stable mode	Trace	Trace
Stable value	0.30 dB	0.30 dB
Run	22 / max. 150	max. 150
Stable	3 / 3	3
Max Stable Difference	0.14 dB	0.30 dB

7.4 Fundamental Emission Output Power – FCC: 15.247(b)(3), ISED Canada: RSS-247 5.4(d)

7.4.1 Measurement Procedure

The maximum conducted output power was measured in accordance with FCC KDB 558074 D01 utilizing the RBW ≥ DTS Bandwidth method. The RF output of the equipment under test was directly connected to the input of the analyzer applying suitable attenuation. Worst-case power across all data rates is reported.

7.4.2 Measurement Results

Performed by: Divya Adusumilli

Table 7.4.2-1: Conducted Output Power

Modulation	Frequency [MHz]	Peak Power [dBm]
O-QPSK / 250kbps	2405	11.4
	2440	11.1
	2475	10.9
	2480	-0.9

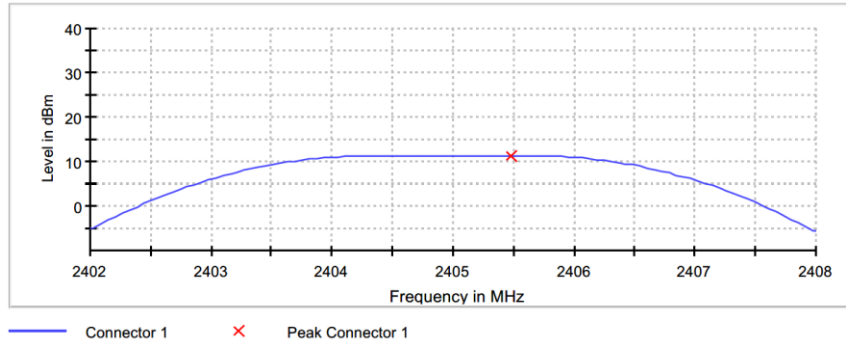

Figure 7.4.2-1: 2405MHz Plot

Table 7.4.2-2: Measurement Settings

Setting	Instrument Value	Target Value
Start Frequency	2.40200 GHz	2.40200 GHz
Stop Frequency	2.40800 GHz	2.40800 GHz
Span	6.000 MHz	6.000 MHz
RBW	2.000 MHz	>= 1.743 MHz
VBW	10.000 MHz	>= 6.000 MHz
Sweep Points	101	~ 101
Sweep time	953.450 ns	AUTO
Reference Level	20.000 dBm	20.000 dBm
Attenuation	40.000 dB	AUTO
Detector	MaxPeak	MaxPeak
Sweep Count	100	100
Filter	3 dB	3 dB
Trace Mode	Max Hold	Max Hold
Sweep type	FFT	AUTO
Preamp	off	off
Stable mode	Trace	Trace
Stable value	0.50 dB	0.50 dB
Run	4 / max. 150	max. 150
Stable	3 / 3	3
Max Stable Difference	0.04 dB	0.50 dB

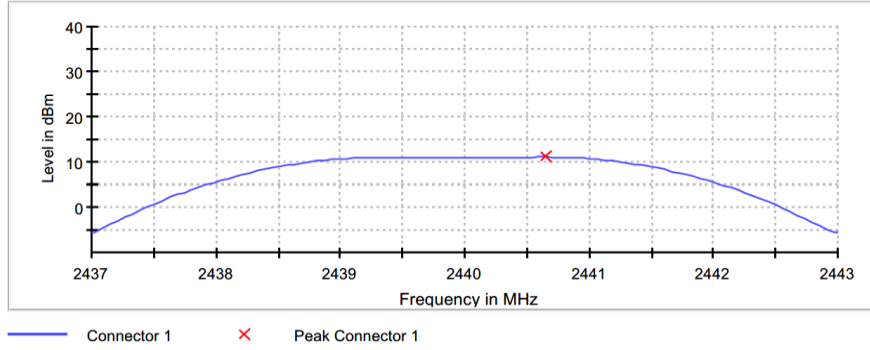
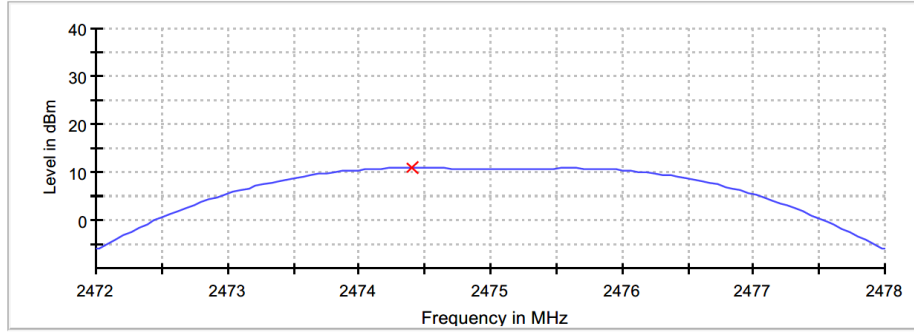

Table 7.4.2-3: Measurement Settings

Setting	Instrument Value	Target Value
Start Frequency	2.43700 GHz	2.43700 GHz
Stop Frequency	2.44300 GHz	2.44300 GHz
Span	6.000 MHz	6.000 MHz
RBW	2.000 MHz	>= 1.743 MHz
VBW	10.000 MHz	>= 6.000 MHz
Sweep Points	101	~ 101
Sweep time	953.450 ns	AUTO
Reference Level	20.000 dBm	20.000 dBm
Attenuation	40.000 dB	AUTO
Detector	MaxPeak	MaxPeak
Sweep Count	100	100
Filter	3 dB	3 dB
Trace Mode	Max Hold	Max Hold
Sweep type	FFT	AUTO
Preamp	off	off
Stable mode	Trace	Trace
Stable value	0.50 dB	0.50 dB
Run	4 / max. 150	max. 150
Stable	3 / 3	3
Max Stable Difference	0.03 dB	0.50 dB



— Connector 1 × Peak Connector 1

Figure 7.4.2-3: 2475MHz Plot

Table 7.4.2-4: Measurement Settings

Setting	Instrument Value	Target Value
Start Frequency	2.47200 GHz	2.47200 GHz
Stop Frequency	2.47800 GHz	2.47800 GHz
Span	6.000 MHz	6.000 MHz
RBW	2.000 MHz	>= 1.743 MHz
VBW	10.000 MHz	>= 6.000 MHz
Sweep Points	101	~ 101
Sweep time	953.450 ns	AUTO
Reference Level	20.000 dBm	20.000 dBm
Attenuation	40.000 dB	AUTO
Detector	MaxPeak	MaxPeak
Sweep Count	100	100
Filter	3 dB	3 dB
Trace Mode	Max Hold	Max Hold
Sweep type	FFT	AUTO
Preamp	off	off
Stable mode	Trace	Trace
Stable value	0.50 dB	0.50 dB
Run	4 / max. 150	max. 150
Stable	3 / 3	3
Max Stable Difference	0.01 dB	0.50 dB

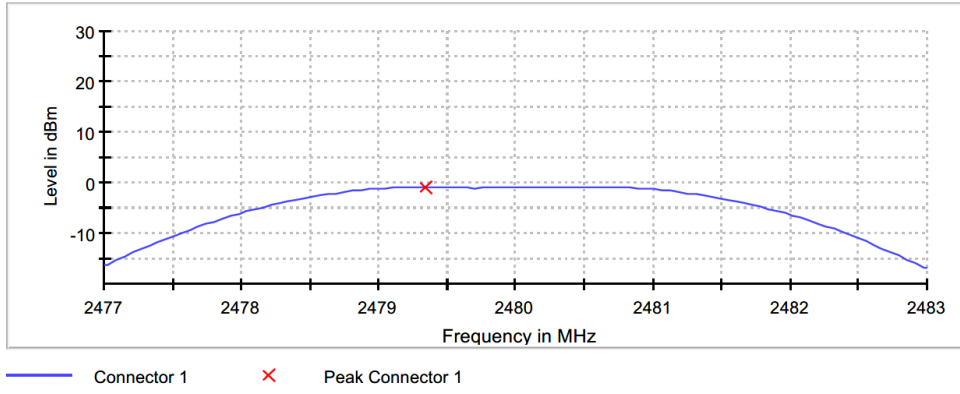

Figure 7.4.2-4: 2480MHz Plot

Table 7.4.2-5: Measurement Settings

Setting	Instrument Value	Target Value
Start Frequency	2.47700 GHz	2.47700 GHz
Stop Frequency	2.48300 GHz	2.48300 GHz
Span	6.000 MHz	6.000 MHz
RBW	2.000 MHz	>= 1.743 MHz
VBW	10.000 MHz	>= 6.000 MHz
Sweep Points	101	~ 101
Sweep time	953.450 ns	AUTO
Reference Level	20.000 dBm	20.000 dBm
Attenuation	40.000 dB	AUTO
Detector	MaxPeak	MaxPeak
Sweep Count	100	100
Filter	3 dB	3 dB
Trace Mode	Max Hold	Max Hold
Sweep type	FFT	AUTO
Preamp	off	off
Stable mode	Trace	Trace
Stable value	0.50 dB	0.50 dB
Run	4 / max. 150	max. 150
Stable	3 / 3	3
Max Stable Difference	0.29 dB	0.50 dB

7.5 Emission Levels

7.5.1 Emissions into Non-restricted Frequency Bands – FCC: 15.247(d); ISED Canada: RSS-247 5.5

7.5.1.1 Measurement Procedure

The unwanted emissions into non-restricted bands were measured conducted in accordance with FCC KDB 558074 D01 Section 8.5. The RF output of the equipment under test was directly connected to the input of the spectrum analyzer applying suitable attenuation. The Resolution Bandwidth (RBW) of the spectrum analyzer was set to 100 kHz. The Video Bandwidth (VBW) was set to ≥ 300 kHz. The resulting spectrum analyzer peak level was used to determine the reference level with respect to the 20 dBc limit at the band edges. The spectrum span was then adjusted for the measurement of spurious emissions from 30MHz to 25GHz, 10 times the highest fundamental frequency. The worst-case for each modulation was investigated at the lower and upper band edges.

7.5.1.2 Measurement Results

Performed by: Divya Adusumilli

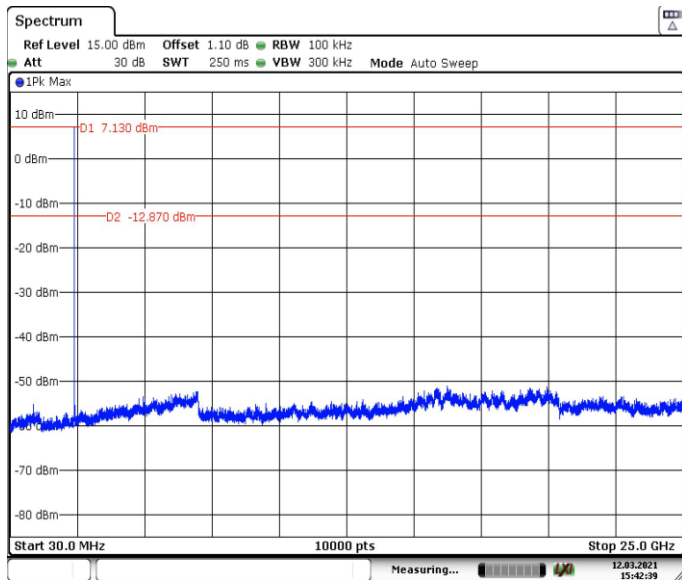

Figure 7.5.1.2-1: LCH (2405MHz) – 30MHz–25GHz

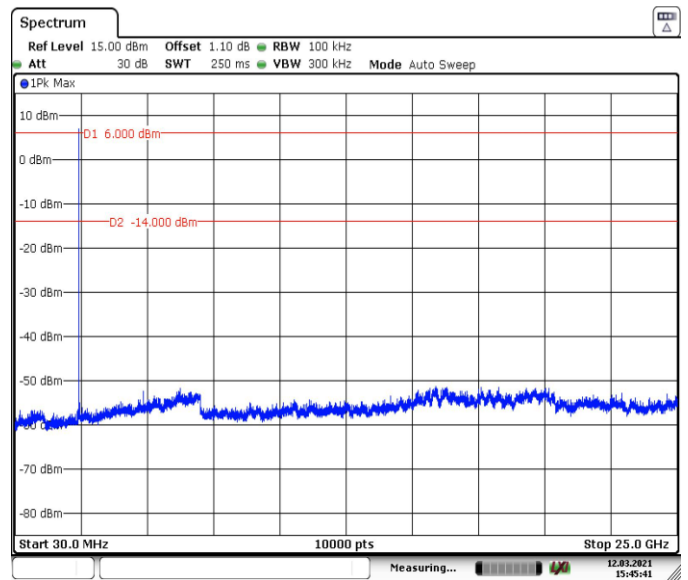

Figure 7.5.1.2-2: MCH (2440MHz) – 30MHz–25GHz

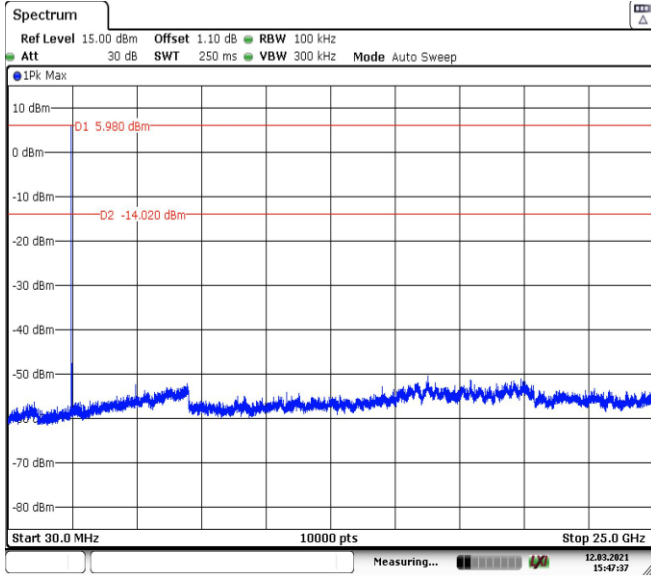

Figure 7.5.1.2-3: HCH (2475MHz) – 30MHz–25GHz

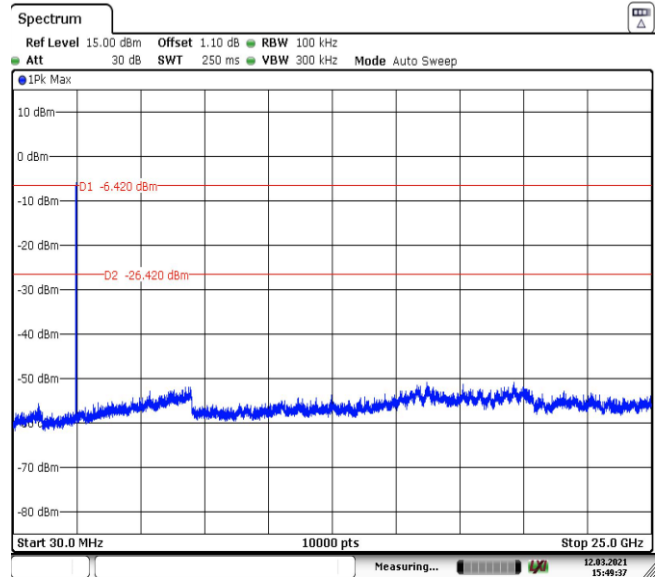

Figure 7.5.1.2-4: HCH (2480MHz) – 30MHz–25GHz

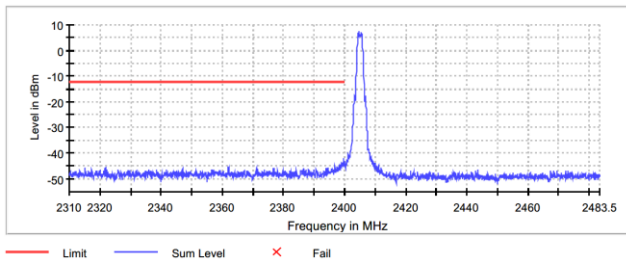

Figure 7.5.1.2-5: Lower Band-edge

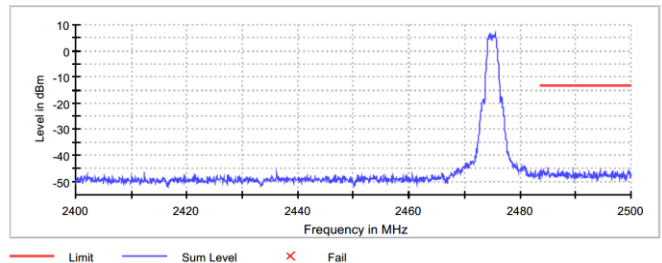

Figure 7.5.1.2-6: Upper Band-edge (2475MHz)

Table 7.5.1.2-1: Lower Band-edge- Low Channel

Frequency (MHz)	Level (dBm)	Margin (dB)	Limit (dBm)	Result
2399.675000	-41.9	29.4	-12.5	PASS
2399.725000	-42.5	30.1	-12.5	PASS
2399.625000	-42.6	30.1	-12.5	PASS
2399.975000	-43.1	30.6	-12.5	PASS
2399.225000	-43.7	31.3	-12.5	PASS
2398.925000	-43.9	31.4	-12.5	PASS
2399.475000	-43.9	31.4	-12.5	PASS
2399.275000	-44.0	31.5	-12.5	PASS
2399.575000	-44.0	31.5	-12.5	PASS
2398.975000	-44.0	31.6	-12.5	PASS
2399.425000	-44.1	31.6	-12.5	PASS
2398.875000	-44.1	31.6	-12.5	PASS
2399.075000	-44.1	31.6	-12.5	PASS
2398.475000	-44.2	31.8	-12.5	PASS
2399.875000	-44.3	31.8	-12.5	PASS

Table 7.5.1.2-2: Upper Band-edge – High Channel (2475MHz)

Frequency (MHz)	Level (dBm)	Margin (dB)	Limit (dBm)	Result
2483.725000	-45.6	32.5	-13.1	PASS
2484.275000	-45.7	32.6	-13.1	PASS
2484.225000	-45.8	32.7	-13.1	PASS
2485.075000	-45.8	32.7	-13.1	PASS
2485.025000	-45.9	32.8	-13.1	PASS
2486.775000	-45.9	32.8	-13.1	PASS
2487.625000	-45.9	32.8	-13.1	PASS
2484.175000	-45.9	32.8	-13.1	PASS
2496.625000	-46.0	32.9	-13.1	PASS
2484.125000	-46.0	32.9	-13.1	PASS
2494.425000	-46.0	32.9	-13.1	PASS
2483.675000	-46.0	32.9	-13.1	PASS
2494.375000	-46.1	32.9	-13.1	PASS
2486.825000	-46.1	33.0	-13.1	PASS
2497.525000	-46.2	33.1	-13.1	PASS

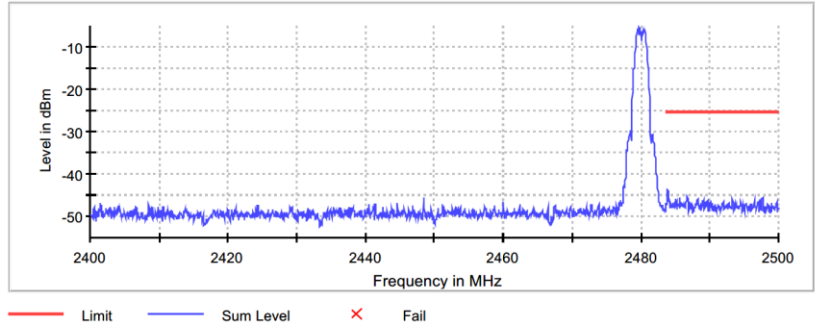

Figure 7.5.1.2-7: Upper Band-edge (2480MHz)

Table 7.5.1.2-3: Upper Band-edge – High Channel (2480MHz)

Frequency (MHz)	Level (dBm)	Margin (dB)	Limit (dBm)	Result
2483.875000	-43.8	18.5	-25.3	PASS
2483.925000	-43.9	18.6	-25.3	PASS
2486.725000	-45.4	20.1	-25.3	PASS
2483.825000	-45.5	20.2	-25.3	PASS
2497.675000	-45.6	20.3	-25.3	PASS
2485.625000	-45.8	20.5	-25.3	PASS
2486.775000	-45.8	20.5	-25.3	PASS
2485.575000	-45.9	20.6	-25.3	PASS
2497.625000	-45.9	20.6	-25.3	PASS
2484.975000	-46.0	20.7	-25.3	PASS
2493.325000	-46.1	20.8	-25.3	PASS
2488.225000	-46.1	20.8	-25.3	PASS
2485.675000	-46.1	20.8	-25.3	PASS
2488.875000	-46.1	20.8	-25.3	PASS
2486.575000	-46.2	20.9	-25.3	PASS

7.5.2 Emissions into Restricted Frequency Bands – FCC: 15.205, 15.209; ISED Canada: RSS-Gen 8.9 / 8.10

7.5.2.1 Measurement Procedure

The unwanted emissions into restricted bands were measured radiated over the frequency range of 30MHz to 25GHz, 10 times the highest fundamental frequency.

The EUT was rotated through 360° and the receive antenna height was varied from 1 meter to 4 meters so that the maximum radiated emissions level would be detected. For frequencies below 1000 MHz, quasi-peak measurements were made using a resolution bandwidth RBW of 120 kHz and a video bandwidth VBW of 300 kHz. For frequencies above 1000 MHz, peak and average measurements were made with RBW and VBW of 1 MHz and 3 MHz respectively.

Each emission found to be in a restricted band as defined by section 15.205, including any emission at the operational band-edge, was compared to the radiated emission limits as defined in section 15.209.

7.5.2.2 Measurement Results

Performed by: Paul Villarreal

Table 7.5.2.2-1: Radiated Spurious Emissions Tabulated Data – Isolated Magnetic Dipole Antenna

Frequency (MHz)	Level (dBuV)		Antenna Polarity (H/V)	Correction Factors (dB)	Corrected Level (dBuV/m)		Limit (dBuV/m)		Margin (dB)	
	pk	Qpk/Avg			pk	Qpk/Avg	pk	Qpk/Avg	pk	Qpk/Avg
Channel 11 (2405 MHz)										
2389.36	42.80	28.50	H	4.83	47.63	33.33	74.0	54.0	26.4	20.7
2389.44	43.50	29.50	V	4.83	48.33	34.33	74.0	54.0	25.7	19.7
Channel 18 (2440 MHz)										
No spurious emissions detected above the equipment noise floor.										
Channel 25 (2475 MHz)										
2483.9	46.7	32.2	H	4.95	51.65	37.15	74.0	54.0	22.4	16.9
2483.66	48.9	35.5	V	4.95	53.85	40.45	74.0	54.0	20.2	13.6
Channel 26 (2480 MHz)										
2483.5	46.8	32.6	H	4.95	51.75	37.55	74.0	54.0	22.3	16.5
2483.5	48.9	35	V	4.95	53.85	39.95	74.0	54.0	20.2	14.1

**7.6 Maximum Power Spectral Density in the Fundamental Emission – FCC: 15.247(e)
ISED Canada: RSS-247 5.2(b)****7.6.1 Measurement Procedure**

The power spectral density was measured in accordance with the FCC KDB 558074 D01 utilizing Section 8.4. The RF output of the equipment under test was directly connected to the input of the spectrum analyzer applying suitable attenuation. The Resolution Bandwidth (RBW) of the spectrum analyzer was set to 10 kHz. The Video Bandwidth (VBW) was set to 30 kHz. Span was set to 1.5 times the channel bandwidth. The trace was set to max hold with the peak detector active.

7.6.2 Measurement Results

Performed by: Divya Adusumilli

Table 7.6.2-1: Power Spectral Density

Modulation	Frequency [MHz]	PSD [dBm]
O-QPSK / 250kbps	2405	0.276
	2440	-0.021
	2475	-0.246
	2480	-12.247

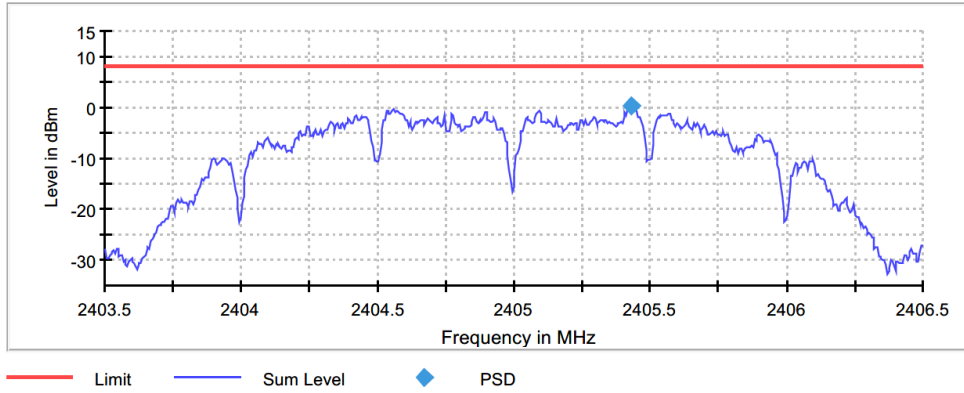

Figure 7.6.2-1: 2405MHz PSD Plot

Table 7.6.2-2: Measurement Settings (PSD)

Setting	Instrument Value	Target Value
Start Frequency	2.40350 GHz	2.40350 GHz
Stop Frequency	2.40650 GHz	2.40650 GHz
Span	3.000 MHz	3.000 MHz
RBW	10.000 kHz	<= 10.000 kHz
VBW	30.000 kHz	>= 30.000 kHz
Sweep Points	600	~ 600
Sweep time	3.000 ms	AUTO
Reference Level	10.000 dBm	10.000 dBm
Attenuation	30.000 dB	AUTO
Detector	MaxPeak	MaxPeak
Sweep Count	100	100
Filter	3 dB	3 dB
Trace Mode	Max Hold	Max Hold
Sweep type	Sweep	Sweep
Preamp	off	off
Stable mode	Trace	Trace
Stable value	0.50 dB	0.50 dB
Run	15 / max. 150	max. 150
Stable	2 / 2	2
Max Stable Difference	0.14 dB	0.50 dB

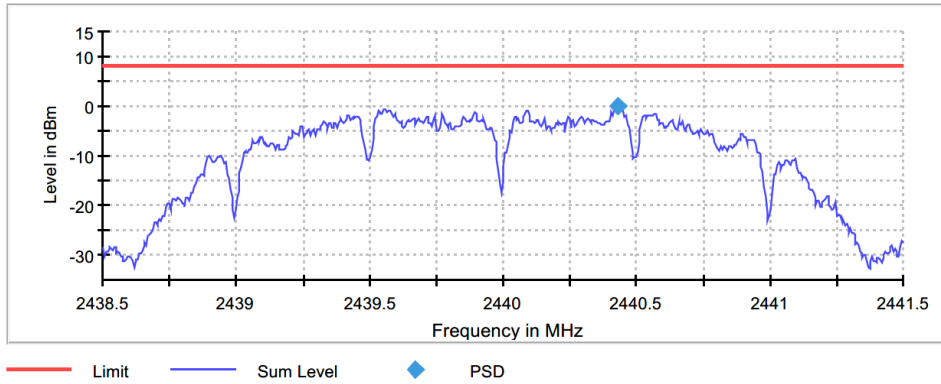

Figure 7.6.2-2: 2440MHz PSD Plot

Table 7.6.2-3: Measurement Settings (PSD)

Setting	Instrument Value	Target Value
Start Frequency	2.43850 GHz	2.43850 GHz
Stop Frequency	2.44150 GHz	2.44150 GHz
Span	3.000 MHz	3.000 MHz
RBW	10.000 kHz	<= 10.000 kHz
VBW	30.000 kHz	>= 30.000 kHz
Sweep Points	600	~ 600
Sweep time	3.000 ms	AUTO
Reference Level	10.000 dBm	10.000 dBm
Attenuation	30.000 dB	AUTO
Detector	MaxPeak	MaxPeak
Sweep Count	100	100
Filter	3 dB	3 dB
Trace Mode	Max Hold	Max Hold
Sweep type	Sweep	Sweep
Preamp	off	off
Stable mode	Trace	Trace
Stable value	0.50 dB	0.50 dB
Run	15 / max. 150	max. 150
Stable	2 / 2	2
Max Stable Difference	0.28 dB	0.50 dB

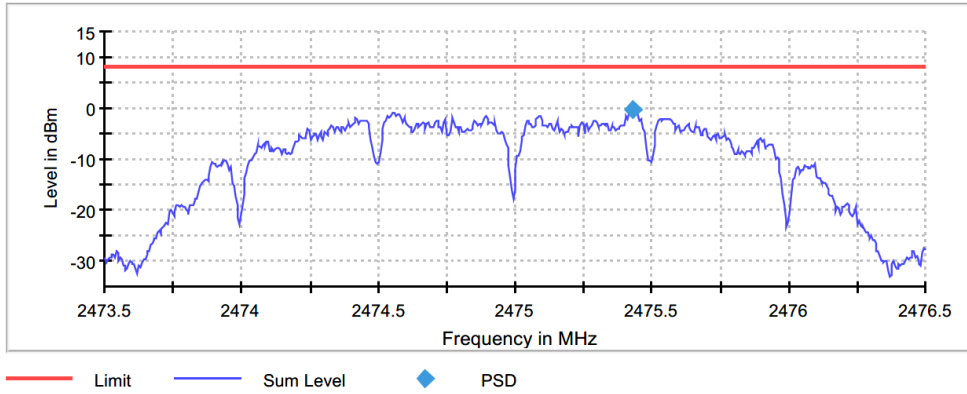

Figure 7.6.2-3: 2475MHz PSD Plot

Table 7.6.2-4: Measurement Settings (PSD)

Setting	Instrument Value	Target Value
Start Frequency	2.47350 GHz	2.47350 GHz
Stop Frequency	2.47650 GHz	2.47650 GHz
Span	3.000 MHz	3.000 MHz
RBW	10.000 kHz	<= 10.000 kHz
VBW	30.000 kHz	>= 30.000 kHz
Sweep Points	600	~ 600
Sweep time	3.000 ms	AUTO
Reference Level	10.000 dBm	10.000 dBm
Attenuation	30.000 dB	AUTO
Detector	MaxPeak	MaxPeak
Sweep Count	100	100
Filter	3 dB	3 dB
Trace Mode	Max Hold	Max Hold
Sweep type	Sweep	Sweep
Preamp	off	off
Stable mode	Trace	Trace
Stable value	0.50 dB	0.50 dB
Run	11 / max. 150	max. 150
Stable	2 / 2	2
Max Stable Difference	0.27 dB	0.50 dB

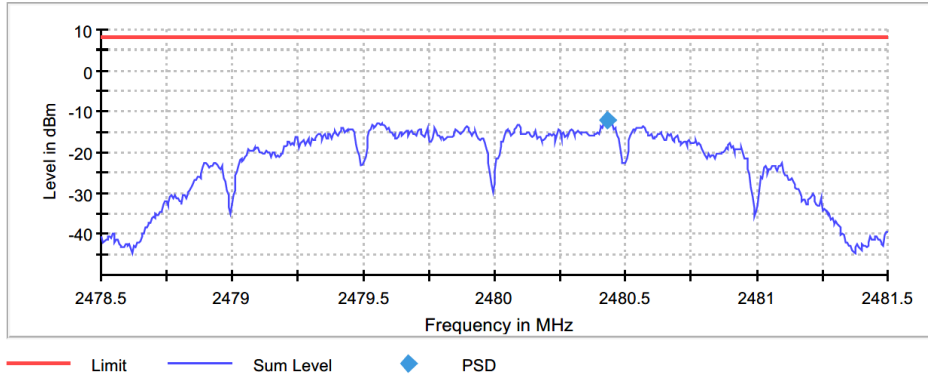

Figure 7.6.2-4: 2480MHz PSD Plot

Table 7.6.2-5: Measurement Settings (PSD)

Setting	Instrument Value	Target Value
Start Frequency	2.47850 GHz	2.47850 GHz
Stop Frequency	2.48150 GHz	2.48150 GHz
Span	3.000 MHz	3.000 MHz
RBW	10.000 kHz	<= 10.000 kHz
VBW	30.000 kHz	>= 30.000 kHz
Sweep Points	600	~ 600
Sweep time	3.000 ms	AUTO
Reference Level	10.000 dBm	10.000 dBm
Attenuation	30.000 dB	AUTO
Detector	MaxPeak	MaxPeak
Sweep Count	100	100
Filter	3 dB	3 dB
Trace Mode	Max Hold	Max Hold
Sweep type	Sweep	Sweep
Preamp	off	off
Stable mode	Trace	Trace
Stable value	0.50 dB	0.50 dB
Run	10 / max. 150	max. 150
Stable	2 / 2	2
Max Stable Difference	0.38 dB	0.50 dB

8 ESTIMATION OF MEASUREMENT UNCERTAINTY

The expanded laboratory measurement uncertainty figures (U_{Lab}) provided below correspond to an expansion factor (coverage factor) $k = 1.96$ which provide confidence levels of 95%.

Table 8-1: Estimation of Measurement Uncertainty

Parameter	U_{lab}
Occupied Channel Bandwidth	$\pm 0.009 \%$
RF Conducted Output Power	$\pm 0.349 \text{ dB}$
Power Spectral Density	$\pm 0.372 \text{ dB}$
Antenna Port Conducted Emissions	$\pm 1.264 \text{ dB}$
Radiated Emissions $\leq 1 \text{ GHz}$	$\pm 5.814 \text{ dB}$
Radiated Emissions $> 1 \text{ GHz}$	$\pm 4.318 \text{ dB}$
Temperature	$\pm 0.860 \text{ }^\circ\text{C}$
Radio Frequency	$\pm 2.832 \times 10^{-8}$
AC Power Line Conducted Emissions	$\pm 3.360 \text{ dB}$

9 CONCLUSION

In the opinion of TUV SUD the WaveLinx Econ Sensor Integrated, Single Chip (model 0550-000716), manufactured by Cooper Lighting LLC meets the requirements of FCC Part 15 subpart C and ISED Canada's Radio Standards Specification RSS-247 for the tests documented herein.

Appendix A: Plots

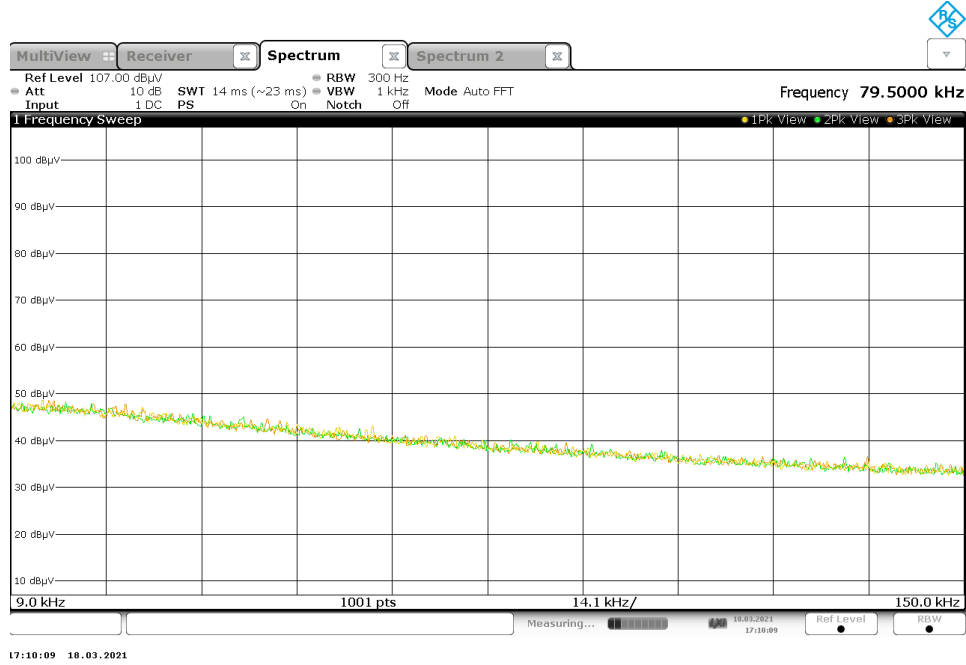
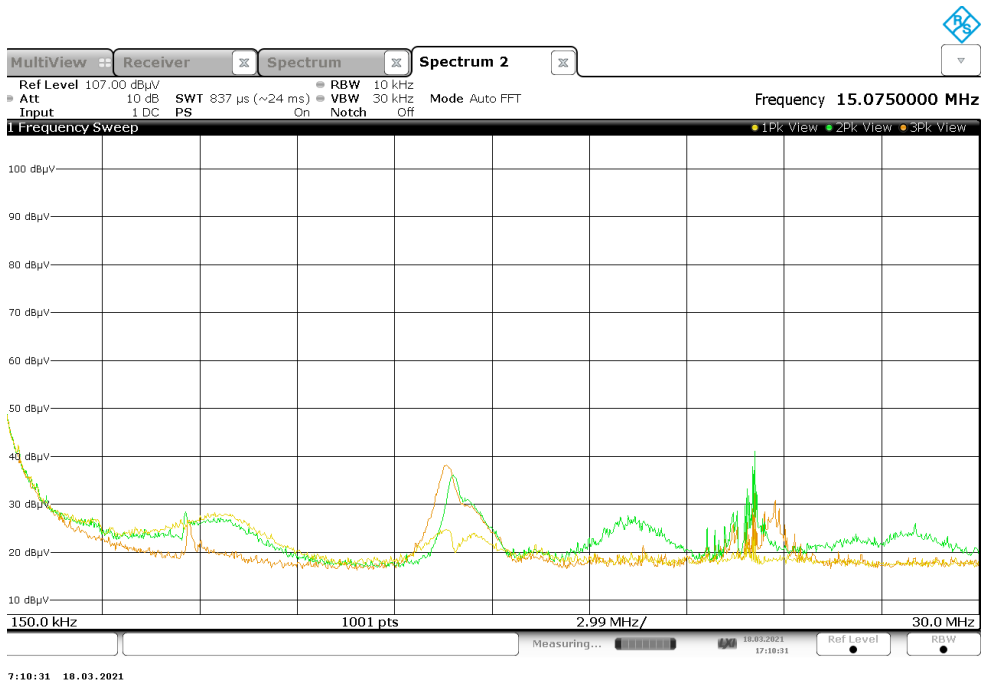
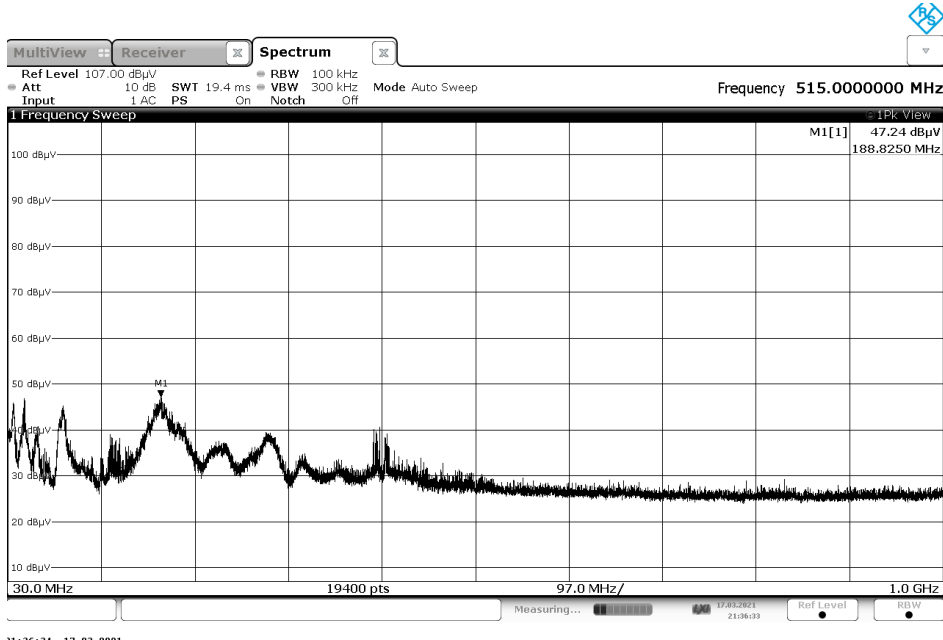

Figure A-1: 9kHz-150kHz



Note: Emissions above the noise floor are not associated with the DUT.
Figure A-2: 150kHz-30MHz



21:36:34 17.03.2021

Note: Emissions above the noise floor are not associated with the radio.
 Figure A-3: 30MHz-1GHz

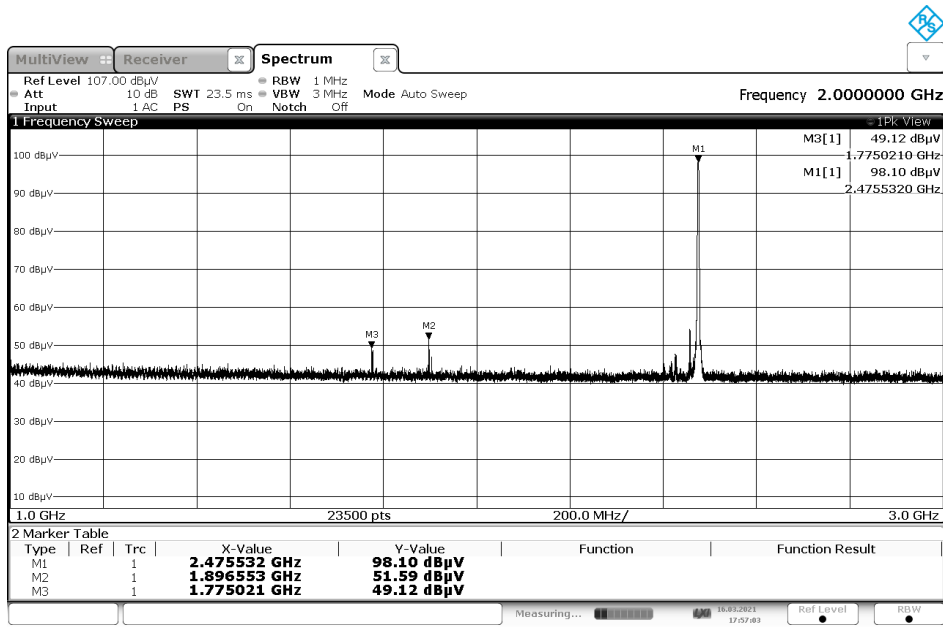

17:57:03 16.03.2021

Note: Emissions above the noise floor are not associated with the radio, except fundamental emission.
 Figure A-4: 1GHz-3GHz

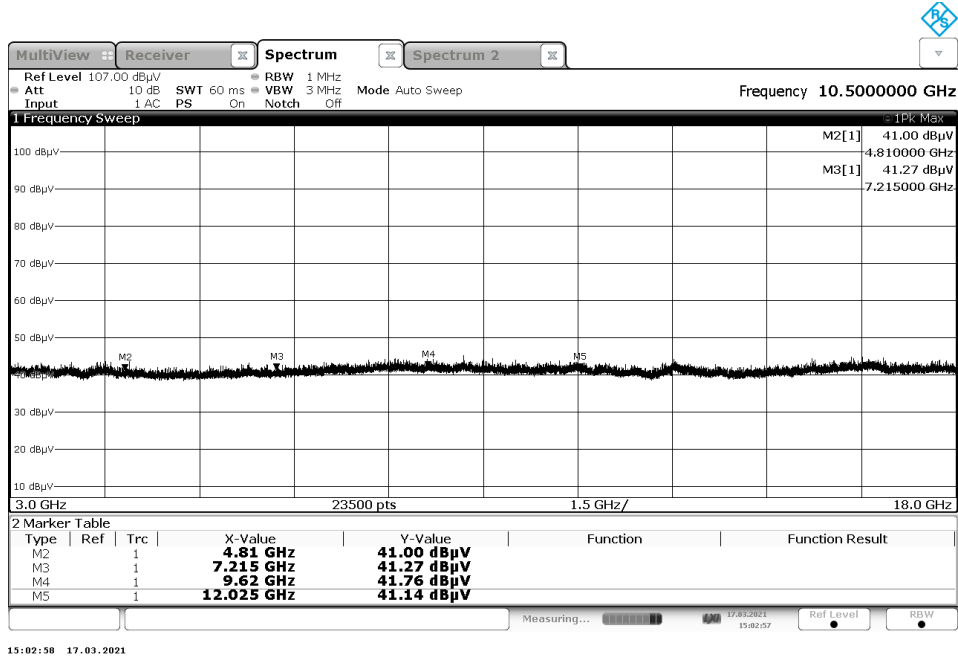

Figure A-5: 3GHz-18GHz

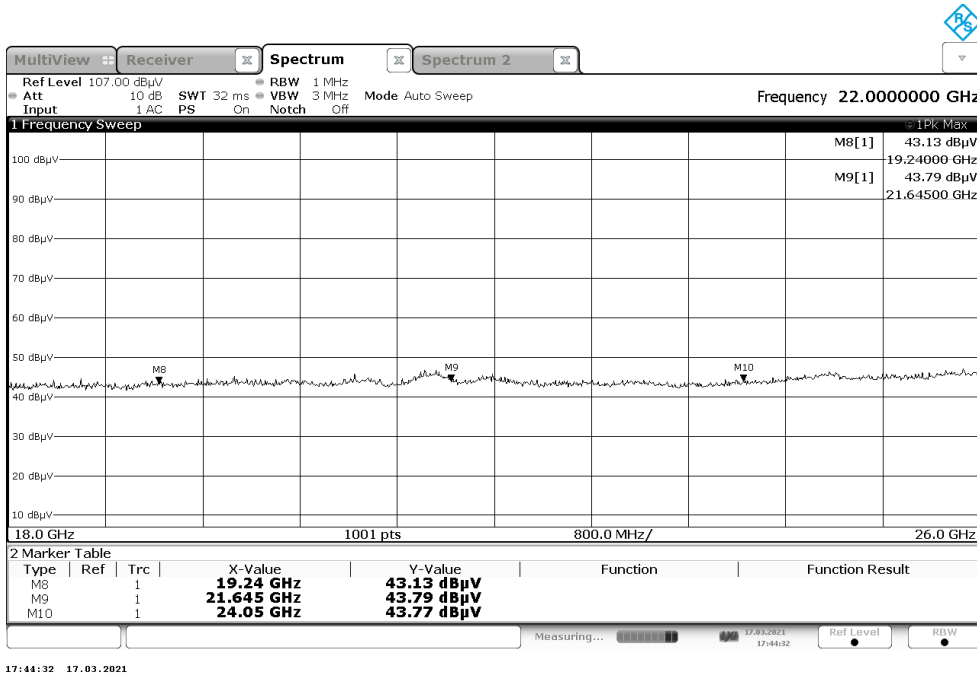

Figure A-6: 18GHz-26GHz

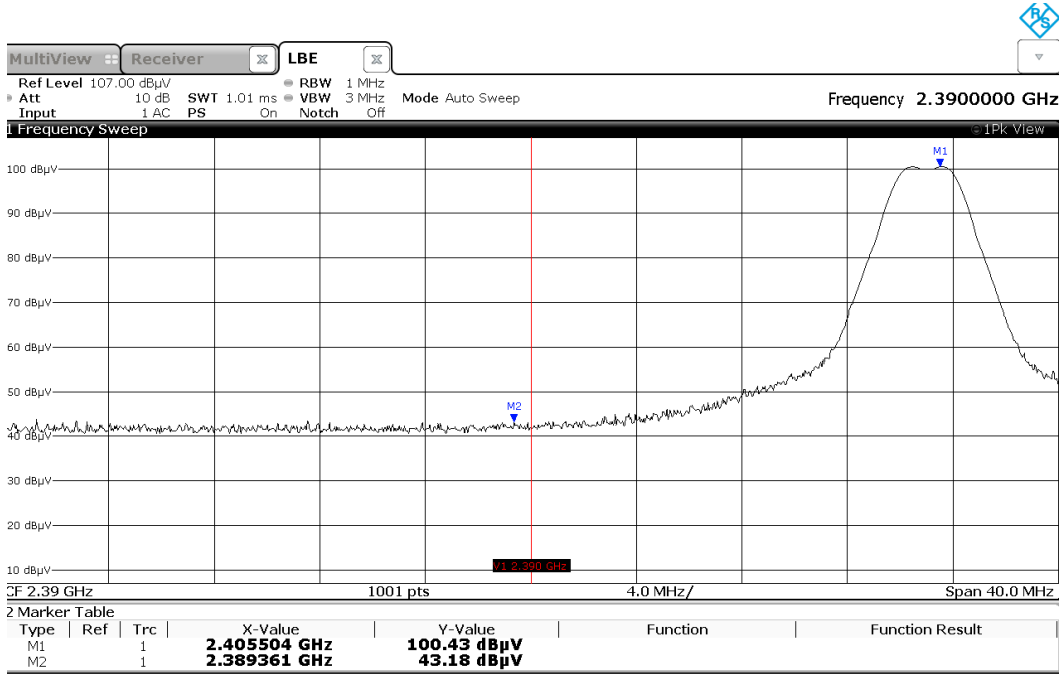

Figure A-7: Restricted Band Edge Low – 2405MHz

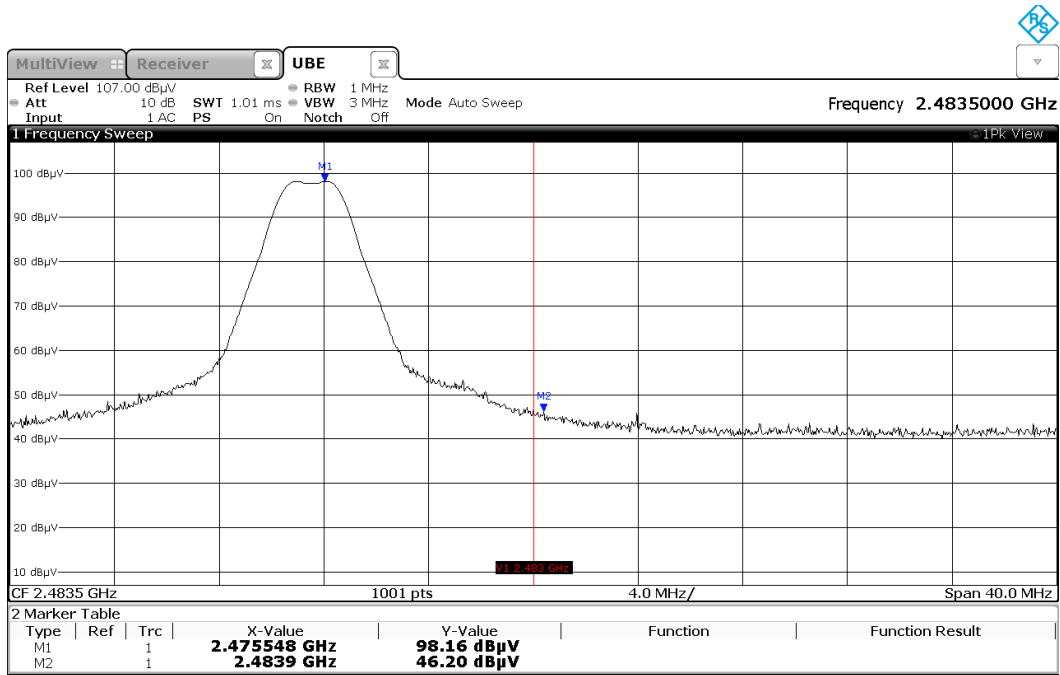

Figure A-8: Restricted Band Edge High – 2475MHz

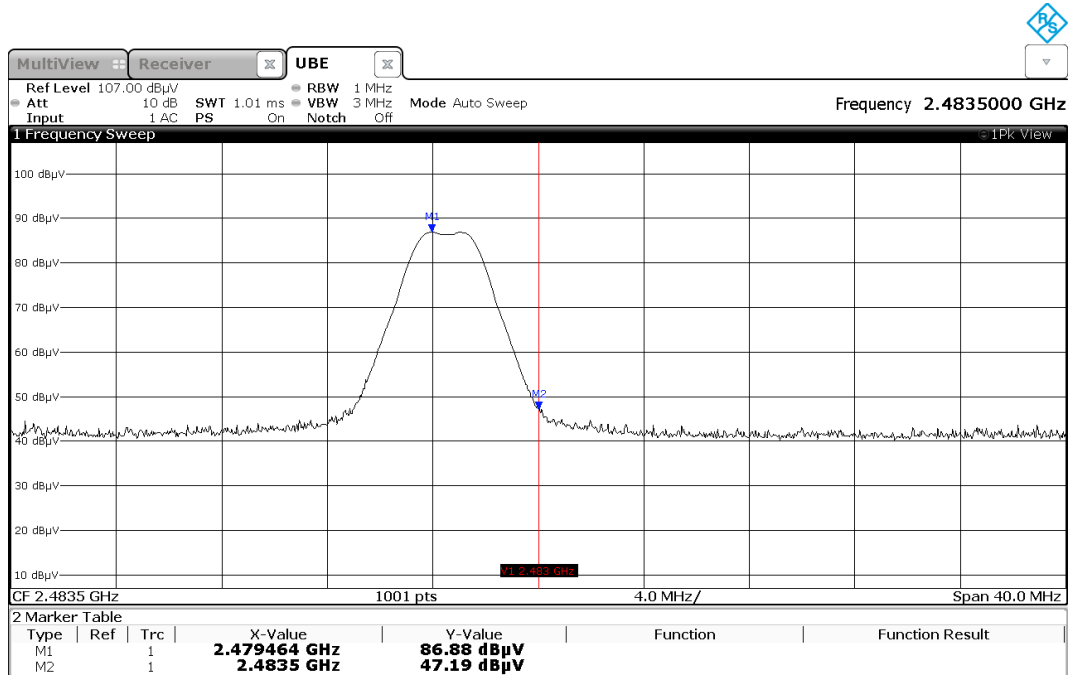

Figure A-9: Restricted Band Edge High – 2480MHz

END REPORT