

# FCC Radio Test Report

## FCC ID: 2AKBP-Q9W

### Original Grant

**Report No.** : TB-FCC162737  
**Applicant** : Shenzhen Hysiry Technology Co., Ltd.  
**Equipment Under Test (EUT)**  
**EUT Name** : SMART LAMP  
**Model No.** : Q9W  
**Series Model No.** : Q9T  
**Brand Name** : Hysiry  
**Receipt Date** : 2018-11-12  
**Test Date** : 2018-11-12 to 2018-11-21  
**Issue Date** : 2018-11-23  
**Standards** : FCC Part 15, Subpart C (15.247: 2018)  
**Test Method** : ANSI C63.10: 2013  
**Conclusions** : **PASS**

In the configuration tested, the EUT complied with the standards specified above,  
The EUT technically complies with the FCC and IC requirements

**Test/Witness Engineer** : Jason Xu  
**Test/Witness Engineer** : Ivan Su  
**Approved & Authorized** : Ray Lai



This report details the results of the testing carried out on one sample. The results contained in this test report do not relate to other samples of the same product. The manufacturer should ensure that all products in series production are in conformity with the product sample detailed in the report.



## Contents

<b>CONTENTS</b> .....	<b>2</b>
<b>1. GENERAL INFORMATION ABOUT EUT</b> .....	<b>5</b>
1.1 Client Information.....	5
1.2 General Description of EUT (Equipment Under Test) .....	5
1.3 Block Diagram Showing the Configuration of System Tested.....	8
1.4 Description of Support Units .....	8
1.5 Description of Test Mode.....	8
1.6 Description of Test Software Setting .....	10
1.7 Measurement Uncertainty .....	10
1.8 Test Facility.....	11
<b>2. TEST SUMMARY</b> .....	<b>12</b>
<b>3. TEST EQUIPMENT</b> .....	<b>13</b>
<b>4. CONDUCTED EMISSION TEST</b> .....	<b>15</b>
4.1 Test Standard and Limit.....	15
4.2 Test Setup.....	15
4.3 Test Procedure.....	15
4.4 EUT Operating Mode .....	16
4.5 Test Data.....	16
<b>5. RADIATED EMISSION TEST</b> .....	<b>17</b>
5.1 Test Standard and Limit.....	17
5.2 Test Setup.....	18
5.3 Test Procedure.....	19
5.4 EUT Operating Condition .....	20
5.5 Test Data.....	20
<b>6. RESTRICTED BANDS REQUIREMENT</b> .....	<b>21</b>
6.1 Test Standard and Limit.....	21
6.2 Test Setup.....	21
6.3 Test Procedure.....	21
6.4 EUT Operating Condition .....	22
6.5 Test Data.....	22
<b>7. BANDWIDTH TEST</b> .....	<b>23</b>
7.1 Test Standard and Limit.....	23
7.2 Test Setup.....	23
7.3 Test Procedure.....	23
7.4 EUT Operating Condition .....	23
7.5 Test Data.....	23



<b>8.</b>	<b>PEAK OUTPUT POWER TEST .....</b>	<b>24</b>
8.1	Test Standard and Limit.....	24
8.2	Test Setup.....	24
8.3	Test Procedure.....	24
8.4	EUT Operating Condition .....	24
8.5	Test Data.....	24
<b>9.</b>	<b>POWER SPECTRAL DENSITY TEST .....</b>	<b>25</b>
9.1	Test Standard and Limit.....	25
9.2	Test Setup.....	25
9.3	Test Procedure.....	25
9.4	EUT Operating Condition .....	25
9.5	Test Data.....	26
<b>10.</b>	<b>ANTENNA REQUIREMENT .....</b>	<b>27</b>
10.1	Standard Requirement.....	27
10.2	Antenna Connected Construction.....	27
	<b>ATTACHMENT A-- CONDUCTED EMISSION TEST DATA .....</b>	<b>28</b>
	<b>ATTACHMENT B-- RADIATED EMISSION TEST DATA .....</b>	<b>40</b>
	<b>ATTACHMENT C-- RESTRICTED BANDS REQUIREMENT TEST DATA .....</b>	<b>64</b>
	<b>ATTACHMENT D-- BANDWIDTH TEST DATA.....</b>	<b>82</b>
	<b>ATTACHMENT E-- PEAK OUTPUT POWER TEST DATA.....</b>	<b>91</b>
	<b>ATTACHMENT F-- POWER SPECTRAL DENSITY TEST DATA .....</b>	<b>95</b>



**Revision History**

Report No.	Version	Description	Issued Date
TB-FCC162737	Rev.01	Initial issue of report	2018-11-23



## 1. General Information about EUT

### 1.1 Client Information

<b>Applicant</b>	:	Shenzhen Hysiry Technology Co., Ltd.
<b>Address</b>	:	No.524, BLDG A, One square world NET Industry Park, Xia Wei Yuan Wan Li Hua Industrial Zone, XiXiang Street, BaoAn District, ShenZhen, China
<b>Manufacturer</b>	:	Shenzhen Hysiry Technology Co., Ltd.
<b>Address</b>	:	No.524, BLDG A, One square world NET Industry Park, Xia Wei Yuan Wan Li Hua Industrial Zone, XiXiang Street, BaoAn District, ShenZhen, China

### 1.2 General Description of EUT (Equipment Under Test)

<b>EUT Name</b>	:	SMART LAMP	
<b>Models No.</b>	:	Q9W, Q9T	
<b>Model Different</b>	:	Power module, wireless module and the appearance of the same, the difference is the light color, and their can match three different lamp boards.	
<b>Product Description</b>	:	Operation Frequency:	802.11b/g/n(HT20): 2412MHz~2462MHz
		Number of Channel:	802.11b/g/n(HT20):11 channels see note(3)
		RF Output Power:	802.11b: 14.65dBm 802.11g: 13.86dBm 802.11n (HT20): 12.91dBm
		Antenna Gain:	1dBi PCB Antenna
		Modulation Type:	802.11b: DSSS(CCK, DQPSK, DBPSK) 802.11g/n: OFDM(BPSK,QPSK,16QAM, 64QAM)
		Bit Rate of Transmitter:	802.11b:11/5.5/2/1 Mbps 802.11g:54/48/36/24/18/12/9/6 Mbps 802.11n:up to 150Mbps
<b>Power Supply</b>	:	AC Voltage supplied	
<b>Power Rating</b>	:	Input: AC 100~240V,50/60Hz	
<b>Software Version</b>	:	N/A	



<b>Hardware Version</b>	:	N/A
<b>Connecting I/O Port(S)</b>	:	Please refer to the User's Manual



**Note:**

- (1) This Test Report is FCC Part 15.247 for 802.11b/g/n, the test procedure follows the FCC KDB 558074 D01 DTS Meas Guidance v05.
- (2) For a more detailed features description, please refer to the manufacturer's specifications or the User's Manual.

(3) Channel List:

Channel	Frequency (MHz)	Channel	Frequency (MHz)	Channel	Frequency (MHz)
01	2412	05	2432	09	2452
02	2417	06	2437	10	2457
03	2422	07	2442	11	2462
04	2427	08	2447		

Note: CH 01~CH 11 for 802.11b/g/n(HT20)

(4) The Antenna information about the equipment is provided by the applicant.

1.3 Block Diagram Showing the Configuration of System Tested

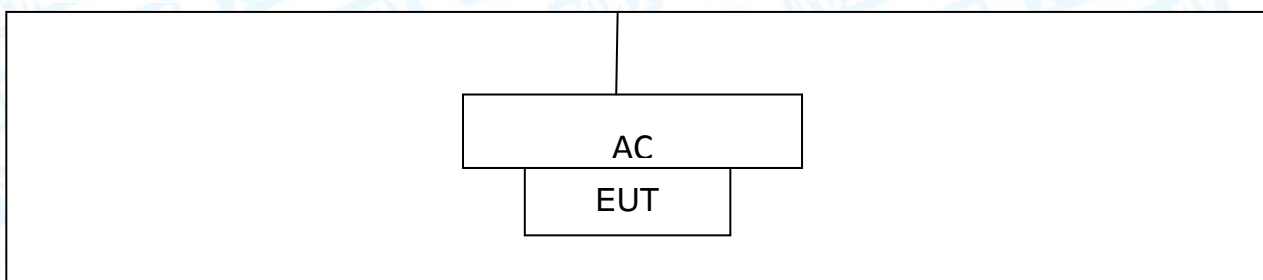
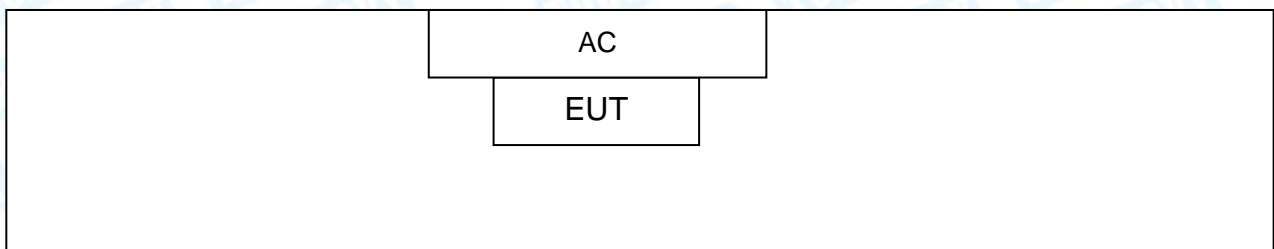

1.4 Description of Support Units

The EUT has been tested as an independent unit.

1.5 Description of Test Mode

To investigate the maximum EMI emission characteristics generates from EUT, the test system was pre-scanning tested base on the consideration of following EUT operation mode or test configuration mode which possible have effect on EMI emission level. Each of these



EUT operation mode(s) or test configuration mode(s) mentioned follow was evaluated respectively.

For Conducted Test	
Final Test Mode	Description
Mode 1	Normal Working with TX B Mode

For Radiated Test	
Final Test Mode	Description
Mode 2	TX Mode B Mode Channel 01/06/11
Mode 3	TX Mode G Mode Channel 01/06/11
Mode 4	TX Mode N(HT20) Mode Channel 01/06/11

**Note:**

- (1) For all test, we have verified the construction and function in typical operation. And all the test modes were carried out with the EUT in transmitting operation in maximum power with all kinds of data rate.  
According to ANSI C63.10 standards, the measurements are performed at the highest, Middle, lowest available channels, and the worst case data rate as follows:
  - 802.11b Mode: CCK (1 Mbps)
  - 802.11g Mode: OFDM (6 Mbps)
  - 802.11n (HT20) Mode: MCS 0 (6.5 Mbps)
- (2) During the testing procedure, the continuously transmitting with the maximum power mode was programmed by the customer.
- (3) The EUT is considered a portable unit; in normal use it was positioned on X-plane. The worst case was found positioned on X-plane. Therefore only the test data of this X-plane was used for radiated emission measurement test.



## 1.6 Description of Test Software Setting

During testing channel & Power controlling software provided by the customer was used to control the operating channel as well as the output power level. The RF output power selection is for the setting of RF output power expected by the customer and is going to be fixed on the firmware of the final end product power parameters of WLAN.

Test Software Version	SecureCRT.exe		
	CH 01	CH 06	CH 11
IEEE 802.11b DSSS	5	10	10
IEEE 802.11g OFDM	30	30	30
IEEE 802.11n (HT20)	30	30	30

## 1.7 Measurement Uncertainty

The reported uncertainty of measurement  $y \pm U$ , where expanded uncertainty  $U$  is based on a standard uncertainty multiplied by a coverage factor of  $k=2$ , providing a level of confidence of approximately 95 %.

Test Item	Parameters	Expanded Uncertainty ( $U_{Lab}$ )
Conducted Emission	Level Accuracy: 9kHz~150kHz	$\pm 3.42$ dB
	150kHz to 30MHz	$\pm 3.42$ dB
Radiated Emission	Level Accuracy: 9kHz to 30 MHz	$\pm 4.60$ dB
Radiated Emission	Level Accuracy: 30MHz to 1000 MHz	$\pm 4.40$ dB
Radiated Emission	Level Accuracy: Above 1000MHz	$\pm 4.20$ dB



## 1.8 Test Facility

The testing report were performed by the Shenzhen Toby Technology Co., Ltd., in their facilities located at 1A/F., Bldg.6, Yusheng Industrial Zone, The National Road No.107 Xixiang Section 467, Xixiang, Bao'an, Shenzhen, Guangdong, China. At the time of testing, the following bodies accredited the Laboratory:

### **CNAS (L5813)**

The Laboratory has been accredited by CNAS to ISO/IEC 17025: 2005 General Requirements for the Competence of Testing and Calibration Laboratories for the competence in the field of testing. And the Registration No.: CNAS L5813.

### **A2LA Certificate No.: 4750.01**

The laboratory has been accredited by American Association for Laboratory Accreditation(A2LA) to ISO/IEC 17025: 2005 General Requirements for the Competence of Testing and Calibration Laboratories for the technical competence in the field of Electrical Testing. And the A2LA Certificate No.: 4750.01. FCC Accredited Test Site Number: 854351.

### **IC Registration No.: (11950A-1)**

The Laboratory has been registered by Certification and Engineering Bureau of Industry Canada for radio equipment testing. The site registration: Site# 11950A-1.



## 2. Test Summary

FCC Part 15 Subpart C(15.247)/ RSS 247 Issue 2				
Standard Section		Test Item	Judgment	Remark
FCC	IC			
15.203	/	Antenna Requirement	PASS	N/A
15.207	RSS-GEN 7.2.4	Conducted Emission	PASS	N/A
15.205	RSS-GEN 7.2.2	Restricted Bands	PASS	N/A
15.247(a)(2)	RSS 247 5.2 (1)	6dB Bandwidth	PASS	N/A
15.247(b)	RSS 247 5.4 (4)	Peak Output Power	PASS	N/A
15.247(e)	RSS 247 5.2 (2)	Power Spectral Density	PASS	N/A
15.247(d)	RSS 247 5.5	Band Edge	PASS	N/A
15.247(d)& 15.209	RSS 247 5.5	Transmitter Radiated Spurious Emission	PASS	N/A

**Note:** "/" for no requirement for this test item.  
N/A is an abbreviation for Not Applicable.



### 3. Test Equipment

Conducted Emission Test					
Equipment	Manufacturer	Model No.	Serial No.	Last Cal.	Cal. Due Date
EMI Test Receiver	Rohde & Schwarz	ESCI	100321	Jul. 18, 2018	Jul. 17, 2019
RF Switching Unit	Compliance Direction Systems Inc	RSU-A4	34403	Jul. 18, 2018	Jul. 17, 2019
AMN	SCHWARZBECK	NNBL 8226-2	8226-2/164	Jul. 18, 2018	Jul. 17, 2019
LISN	Rohde & Schwarz	ENV216	101131	Jul. 18, 2018	Jul. 17, 2019
Radiation Emission Test					
Equipment	Manufacturer	Model No.	Serial No.	Last Cal.	Cal. Due Date
Spectrum Analyzer	Agilent	E4407B	MY45106456	Jul. 18, 2018	Jul. 17, 2019
EMI Test Receiver	Rohde & Schwarz	ESPI	100010/007	Jul. 18, 2018	Jul. 17, 2019
Bilog Antenna	ETS-LINDGREN	3142E	00117537	Mar.16, 2018	Mar. 15, 2019
Bilog Antenna	ETS-LINDGREN	3142E	00117542	Mar.16, 2018	Mar. 15, 2019
Horn Antenna	ETS-LINDGREN	3117	00143207	Mar.16, 2018	Mar. 15, 2019
Horn Antenna	ETS-LINDGREN	3117	00143209	Mar.16, 2018	Mar. 15, 2019
Loop Antenna	SCHWARZBECK	FMZB 1519 B	1519B-059	Jul. 14, 2018	Jul. 13, 2019
Pre-amplifier	Sonoma	310N	185903	Mar.17, 2018	Mar. 16, 2019
Pre-amplifier	HP	8449B	3008A00849	Mar.17, 2018	Mar. 16, 2019
Cable	HUBER+SUHNER	100	SUCOFLEX	Mar.17, 2018	Mar. 16, 2019
Positioning Controller	ETS-LINDGREN	2090	N/A	N/A	N/A
Antenna Conducted Emission					
Equipment	Manufacturer	Model No.	Serial No.	Last Cal.	Cal. Due Date
Spectrum Analyzer	Agilent	E4407B	MY45106456	Jul. 18, 2018	Jul. 17, 2019
Spectrum Analyzer	Rohde & Schwarz	ESCI	100010/007	Jul. 18, 2018	Jul. 17, 2019
MXA Signal Analyzer	Agilent	N9020A	MY49100060	Sep. 15, 2018	Sep. 14, 2019
Vector Signal Generator	Agilent	N5182A	MY50141294	Sep. 15, 2018	Sep. 14, 2019
Analog Signal Generator	Agilent	N5181A	MY50141953	Sep. 15, 2018	Sep. 14, 2019
RF Power Sensor	DARE!! Instruments	RadiPowerRPR3006W	17I00015SNO26	Sep. 15, 2018	Sep. 14, 2019
	DARE!! Instruments	RadiPowerRPR3006W	17I00015SNO29	Sep. 15, 2018	Sep. 14, 2019



	DARE!! Instruments	RadiPowerRPR3006W	17I00015SNO31	Sep. 15, 2018	Sep. 14, 2019
	DARE!! Instruments	RadiPowerRPR3006W	17I00015SNO33	Sep. 15, 2018	Sep. 14, 2019



## 4. Conducted Emission Test

### 4.1 Test Standard and Limit

4.1.1 Test Standard  
FCC Part 15.207

4.1.2 Test Limit

**Conducted Emission Test Limit**

Frequency	Maximum RF Line Voltage (dB $\mu$ V)	
	Quasi-peak Level	Average Level
150kHz~500kHz	66 ~ 56 *	56 ~ 46 *
500kHz~5MHz	56	46
5MHz~30MHz	60	50

Notes:

- (1) \*Decreasing linearly with logarithm of the frequency.
- (2) The lower limit shall apply at the transition frequencies.
- (3) The limit decrease in line with the logarithm of the frequency in the range of 0.15 to 0.50MHz.

### 4.2 Test Setup

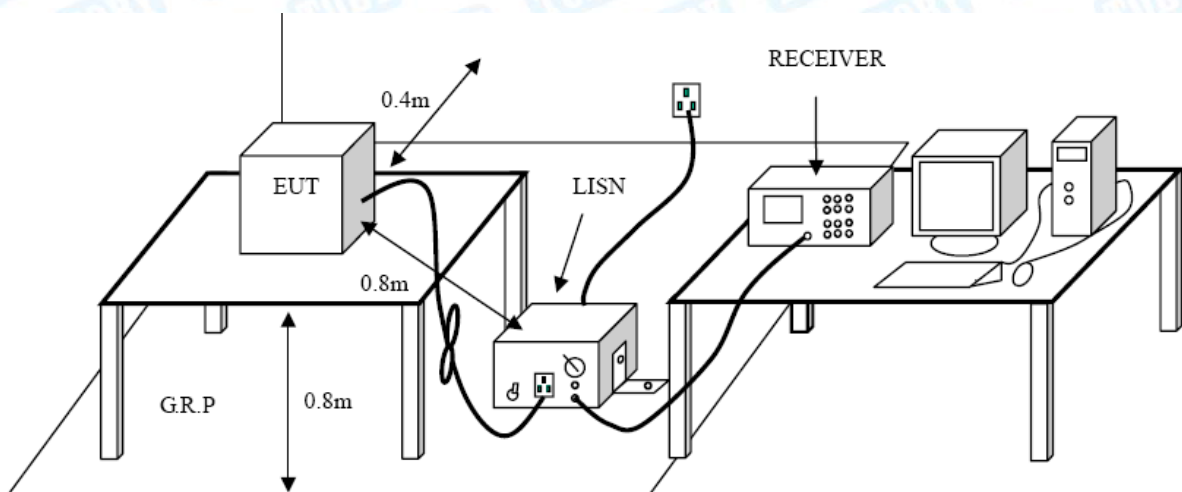

### 4.3 Test Procedure

The EUT was placed 0.8 meters from the horizontal ground plane with EUT being connected to the power mains through a line impedance stabilization network (LISN). All other support equipments powered from additional LISN(s). The LISN provide 50 Ohm/50uH of coupling impedance for the measuring instrument.



Interconnecting cables that hang closer than 40 cm to the ground plane shall be folded back and forth in the center forming a bundle 30 to 40 cm long.

I/O cables that are not connected to a peripheral shall be bundled in the center. The end of the cable may be terminated, if required, using the correct terminating impedance. The overall length shall not exceed 1 m.

LISN at least 80 cm from nearest part of EUT chassis.

The bandwidth of EMI test receiver is set at 9kHz, and the test frequency band is from 0.15MHz to 30MHz.

#### 4.4 EUT Operating Mode

Please refer to the description of test mode.

#### 4.5 Test Data

Please refer to the Attachment A.



## 5. Radiated Emission Test

### 5.1 Test Standard and Limit

#### 5.1.1 Test Standard

FCC Part 15.209

#### 5.1.2 Test Limit

#### Radiated Emission Limits ( 9 kHz~1000 MHz)

Frequency (MHz)	Field Strength (microvolt/meter)	Measurement Distance (meters)
0.009~0.490	2400/F(KHz)	300
0.490~1.705	24000/F(KHz)	30
1.705~30.0	30	30
30~88	100	3
88~216	150	3
216~960	200	3
Above 960	500	3

#### Radiated Emission Limit (Above 1000MHz)

Frequency (MHz)	Distance of 3m (dBuV/m)	
	Peak	Average
Above 1000	74	54

**Note:**

- (1) The tighter limit applies at the band edges.
- (2) Emission Level(dBuV/m)=20log Emission Level(uV/m)



5.2 Test Setup

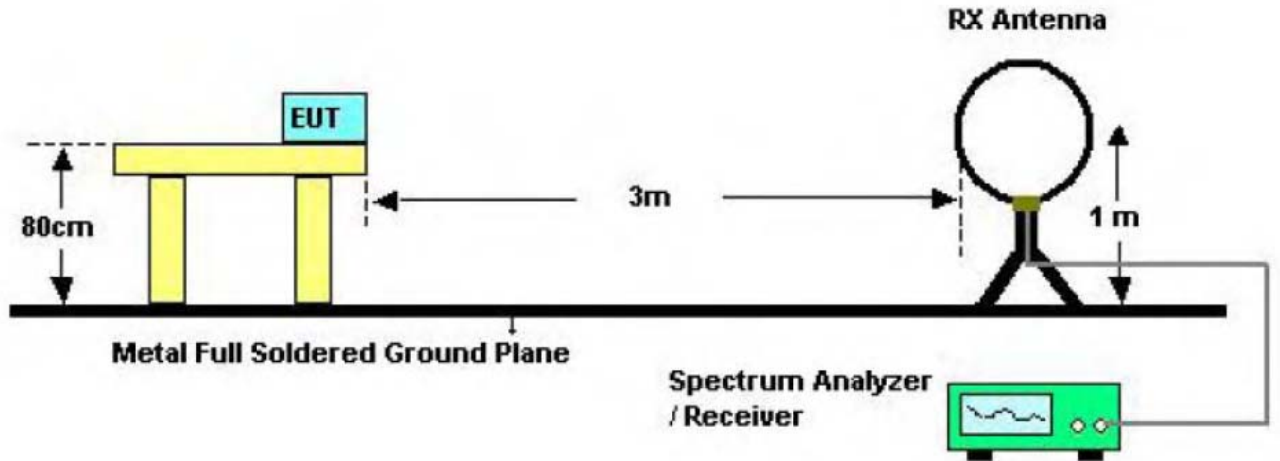

Below 30MHz Test Setup

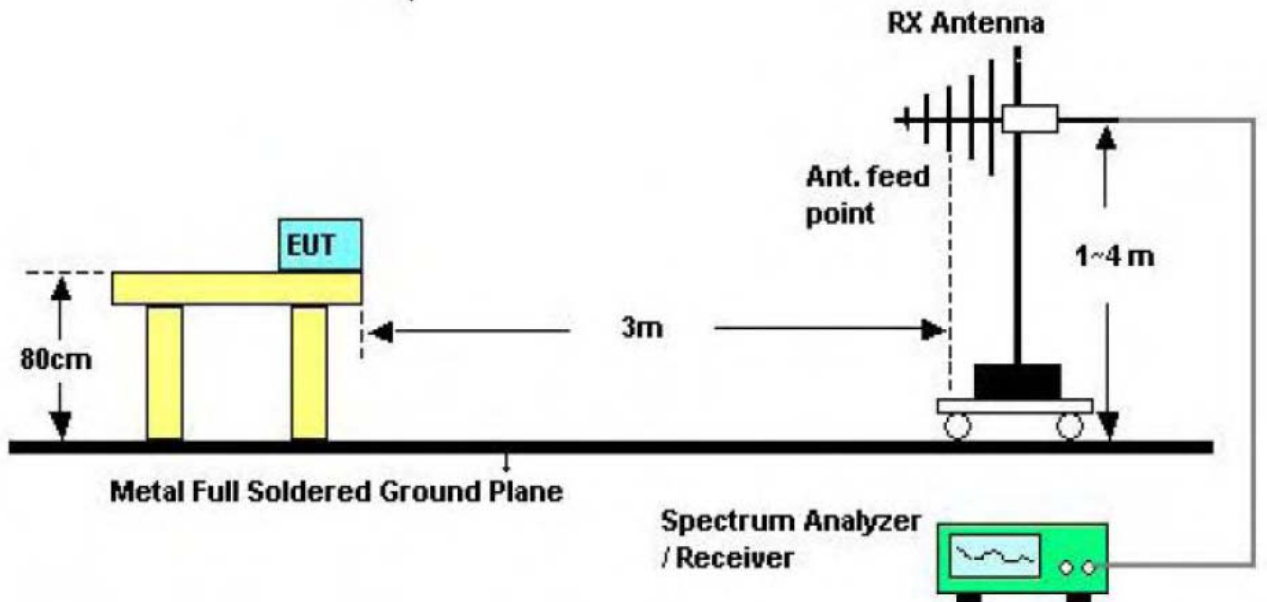

Below 1000MHz Test Setup



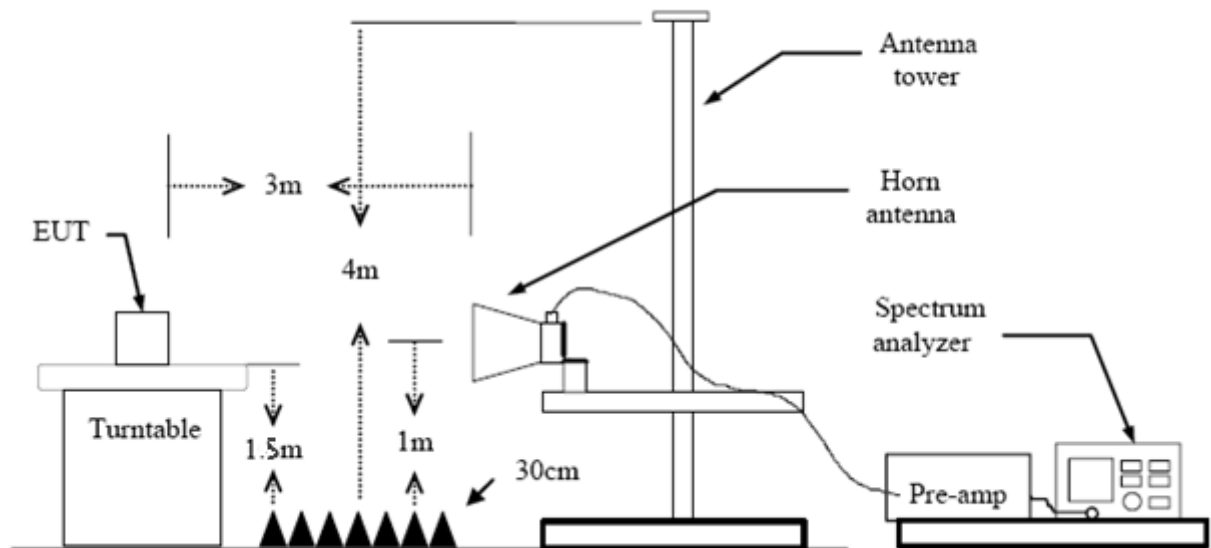

Above 1GHz Test Setup

### 5.3 Test Procedure

- (1) Measurements at frequency above 1GHz. The EUT was placed on a rotating 1.5m high above the ground. RF absorbers covered the ground plane with a minimum area of 3.0m by 3.0m between the EUT and measurement receiver antenna. The RF absorber shall not exceed 30cm in high above the conducting floor. The table was rotated 360 degrees to determine the position of the highest radiation.
- (2) Measurements at frequency Below 1GHz. The EUT was placed on a rotating 0.8m high above the ground. RF absorbers covered the ground plane with a minimum area of 3.0m by 3.0m between the EUT and measurement receiver antenna. The RF absorber shall not exceed 30cm in high above the conducting floor. The table was rotated 360 degrees to determine the position of the highest radiation.
- (3) The Test antenna shall vary between 1m and 4m, Both Horizontal and Vertical antenna are set to make measurement.
- (4) The initial step in collecting conducted emission data is a spectrum analyzer peak detector mode pre-scanning the measurement frequency range. Significant peaks are then marked and then Quasi Peak detector mode re-measured.
- (5) If the Peak Mode measured value compliance with and lower than Quasi Peak Mode Limit Bellow 1 GHz, the EUT shall be deemed to meet QP Limits and then no additional QP Mode measurement performed. But the Peak Value and average value both need to comply with applicable limit above 1 GHz.
- (6) Testing frequency range below 1GHz the measuring instrument use VBW=120 kHz with



Quasi-peak detection.

- (7) Testing frequency range above 1GHz the measuring instrument use RBW=1 MHz and VBW=3 MHz with Peak Detector for Peak Values, and use RBW=1 MHz and VBW=10 Hz with Peak Detector for Average Values.
- (8) For the actual test configuration, please see the test setup photo.

#### 5.4 EUT Operating Condition

The Equipment Under Test was set to Continual Transmitting in maximum power.

#### 5.5 Test Data

Remark: During testing above 1GHz the measuring instrument use RBW=1 MHz and VBW=3 MHz with Peak Detector for Peak Values, and use RBW=1 MHz and VBW=10 Hz with Peak Detector for Average Values.

Please refer to the Attachment B.



## 6. Restricted Bands Requirement

### 6.1 Test Standard and Limit

#### 6.1.1 Test Standard

FCC Part 15.247(d)

FCC Part 15.209

FCC Part 15.205

#### 6.1.2 Test Limit

Restricted Frequency Band (MHz)	Distance of 3m (dBuV/m)	
	Peak	Average
2310 ~2390	74	54
2483.5 ~2500	74	54

### 6.2 Test Setup

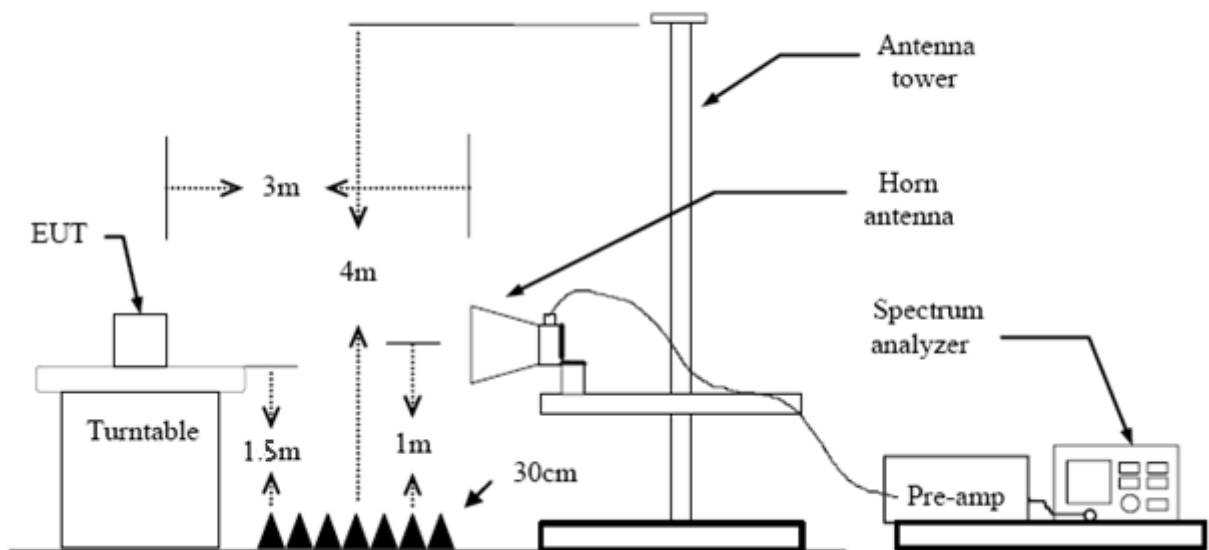

### 6.3 Test Procedure

- (1) The measuring distance of 3m shall be used for measurements at frequency Below 1GHz and above 1 GHz. The EUT was placed on a rotating 0.8m high above ground, the table was rotated 360 degrees to determine the position of the highest radiation.
- (2) Measurements at frequency above 1GHz. The EUT was placed on a rotating 1.5m high above the ground. RF absorbers covered the ground plane with a minimum area of 3.0m by



3.0m between the EUT and measurement receiver antenna. The RF absorber shall not exceed 30cm in high above the conducting floor. The table was rotated 360 degrees to determine the position of the highest radiation.

- (3) The Test antenna shall vary between 1m and 4m, Both Horizontal and Vertical antenna are set to make measurement.
- (4) The initial step in collecting conducted emission data is a spectrum analyzer peak detector mode pre-scanning the measurement frequency range. Significant peaks are then marked and then Quasi Peak detector mode re-measured.
- (5) If the Peak Mode measured value compliance with and lower than Quasi Peak Mode Limit Bellow 1 GHz, the EUT shall be deemed to meet QP Limits and then no additional QP Mode measurement performed. But the Peak Value and average value both need to comply with applicable limit above 1 GHz.
- (6) Testing frequency range below 1GHz the measuring instrument use VBW=120 kHz with Quasi-peak detection.
- (7) Testing frequency range above 1GHz the measuring instrument use RBW=1 MHz and VBW=3 MHz with Peak Detector for Peak Values, and use RBW=1 MHz and VBW=10 Hz with Peak Detector for Average Values.
- (8) For the actual test configuration, please see the test setup photo.

#### 6.4 EUT Operating Condition

The Equipment Under Test was set to Continual Transmitting in maximum power.

#### 6.5 Test Data

Please refer to the Attachment C.



## 7. Bandwidth Test

### 7.1 Test Standard and Limit

#### 7.1.1 Test Standard

FCC Part 15.247 (a)(2)

#### 7.1.2 Test Limit

FCC Part 15 Subpart C(15.247)		
Test Item	Limit	Frequency Range(MHz)
Bandwidth	$\geq 500$ KHz (6dB bandwidth)	2400~2483.5

### 7.2 Test Setup

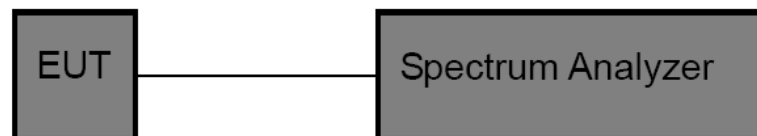

### 7.3 Test Procedure

- (1) The EUT was directly connected to the spectrum analyzer and antenna output port as show in the block diagram above.
- (2) The bandwidth is measured at an amplitude level reduced 6dB from the reference level. The reference level is the level of the highest amplitude signal observed from the transmitter at the fundamental frequency. Once the reference level is established, the equipment is conditioned with typical modulating signal to produce the worst -case (i.e the widest) bandwidth.
- (3) Measure the channel separation the spectrum analyzer was set to Resolution Bandwidth:100 kHz, and Video Bandwidth:300 kHz, Detector: Peak, Sweep Time set auto.

### 7.4 EUT Operating Condition

The EUT was set to continuously transmitting in each mode and low, Digital photo framesdle and high channel for the test.

### 7.5 Test Data

Please refer to the Attachment D.



## 8. Peak Output Power Test

### 8.1 Test Standard and Limit

#### 8.1.1 Test Standard

FCC Part 15.247 (b)

#### 8.1.2 Test Limit

FCC Part 15 Subpart C(15.247)		
Test Item	Limit	Frequency Range(MHz)
Peak Output Power	1 Watt or 30 dBm	2400~2483.5

### 8.2 Test Setup

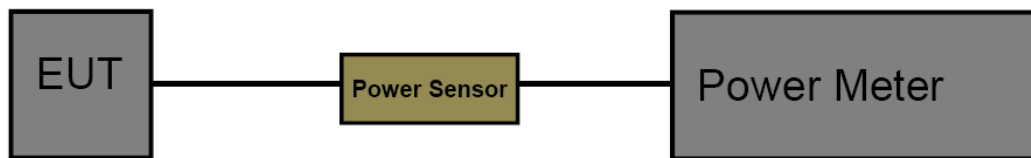

### 8.3 Test Procedure

The measurement is according to section 9.1.2 of KDB 558074 D01 DTS Meas Guidance v05. The EUT was connected to RF power meter via a broadband power sensor as show the block above. The power sensor video bandwidth is greater than or equal to the DTS bandwidth of the equipment.

### 8.4 EUT Operating Condition

The EUT was set to continuously transmitting in the max power during the test.

### 8.5 Test Data

Please refer to the Attachment E.



## 9. Power Spectral Density Test

### 9.1 Test Standard and Limit

#### 9.1.1 Test Standard

FCC Part 15.247 (e)

#### 9.1.2 Test Limit

FCC Part 15 Subpart C(15.247)		
Test Item	Limit	Frequency Range(MHz)
Power Spectral Density	8dBm(in any 3 kHz)	2400~2483.5

### 9.2 Test Setup

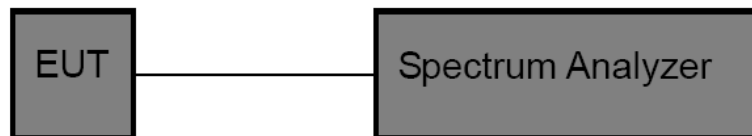

### 9.3 Test Procedure

The EUT was directly connected to the Spectrum Analyzer and antenna output port as show in the block diagram above. The measurement according to section 10.2 of KDB 558074 D01 DTS Meas Guidance v05.

- (1) The EUT was directly connected to the spectrum analyzer and antenna output port as show in the block diagram above.
- (2) Set analyser center frequency to DTS channel center frequency.
- (3) Set the span to 1.5 times the DTS bandwidth.
- (4) Set the RBW to: 3 kHz
- (5) Set the VBW to: 10 kHz
- (6) Detector: peak
- (7) Sweep time: auto
- (8) Allow trace to fully stabilize. Then use the peak marker function to determine the maximum amplitude level.

### 9.4 EUT Operating Condition

The EUT was set to continuously transmitting in each mode and low, Digital photo framesdle and high channel for the test.



## 9.5 Test Data

Please refer to the Attachment F.



## 10. Antenna Requirement

### 10.1 Standard Requirement

#### 10.1.1 Standard

FCC Part 15.203

#### 10.1.2 Requirement

An intentional radiator shall be designed to ensure that no antenna other than that furnished by the responsible party shall be used with the device. The use of a permanently attached antenna or of an antenna that uses a unique coupling to the intentional radiator shall be considered sufficient to comply with the provisions of this Section. The manufacturer may design the unit so that a broken antenna can be replaced by the user, but the use of a standard antenna jack or electrical connector is prohibited.

### 10.2 Antenna Connected Construction

The gains of the antenna used for transmitting is 1dBi, and the antenna de-signed with permanent attachment and no consideration of replacement. Please see the EUT photo for details.

#### Result

The EUT antenna is a PCB Antenna. It complies with the standard requirement.

Antenna Type
<input checked="" type="checkbox"/> Permanent attached antenna
<input type="checkbox"/> Unique connector antenna
<input type="checkbox"/> Professional installation antenna



## Attachment A-- Conducted Emission Test Data

The following 1# lamp board with Q9W test plot.

<b>Temperature:</b>	25 °C	<b>Relative Humidity:</b>	55%
<b>Test Voltage:</b>	AC 120V/60Hz		
<b>Terminal:</b>	Line		
<b>Test Mode:</b>	Normal working with TX B Mode		
<b>Remark:</b>	Only worse case is reported		

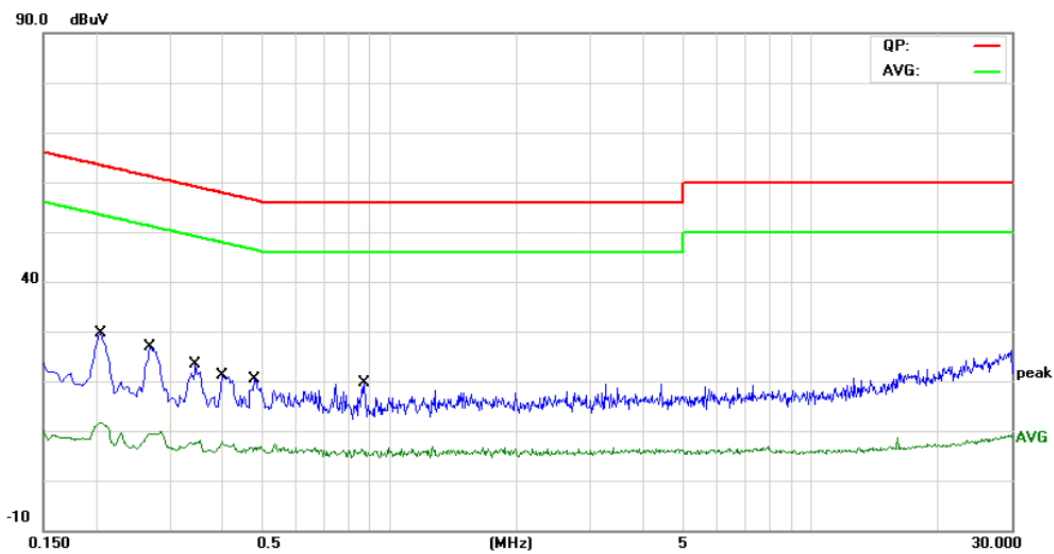

No.	Mk.	Freq. MHz	Reading Level dBuV	Correct Factor dB	Measure- ment dBuV	Limit dBuV	Over dB	Detector
1	*	0.2060	15.53	9.58	25.11	63.36	-38.25	QP
2		0.2060	0.96	9.58	10.54	53.36	-42.82	AVG
3		0.2700	13.04	9.59	22.63	61.12	-38.49	QP
4		0.2700	-0.98	9.59	8.61	51.12	-42.51	AVG
5		0.3460	8.00	9.59	17.59	59.06	-41.47	QP
6		0.3460	-2.78	9.59	6.81	49.06	-42.25	AVG
7		0.3980	4.85	9.60	14.45	57.89	-43.44	QP
8		0.3980	-3.02	9.60	6.58	47.89	-41.31	AVG
9		0.4780	3.16	9.60	12.76	56.37	-43.61	QP
10		0.4780	-4.24	9.60	5.36	46.37	-41.01	AVG
11		0.8700	1.28	9.60	10.88	56.00	-45.12	QP
12		0.8700	-4.52	9.60	5.08	46.00	-40.92	AVG

**Emission Level= Read Level+ Correct Factor**



<b>Temperature:</b>	25 °C	<b>Relative Humidity:</b>	55%
<b>Test Voltage:</b>	AC 120V/60Hz		
<b>Terminal:</b>	Neutral		
<b>Test Mode:</b>	Normal working with TX B Mode		
<b>Remark:</b>	Only worse case is reported		

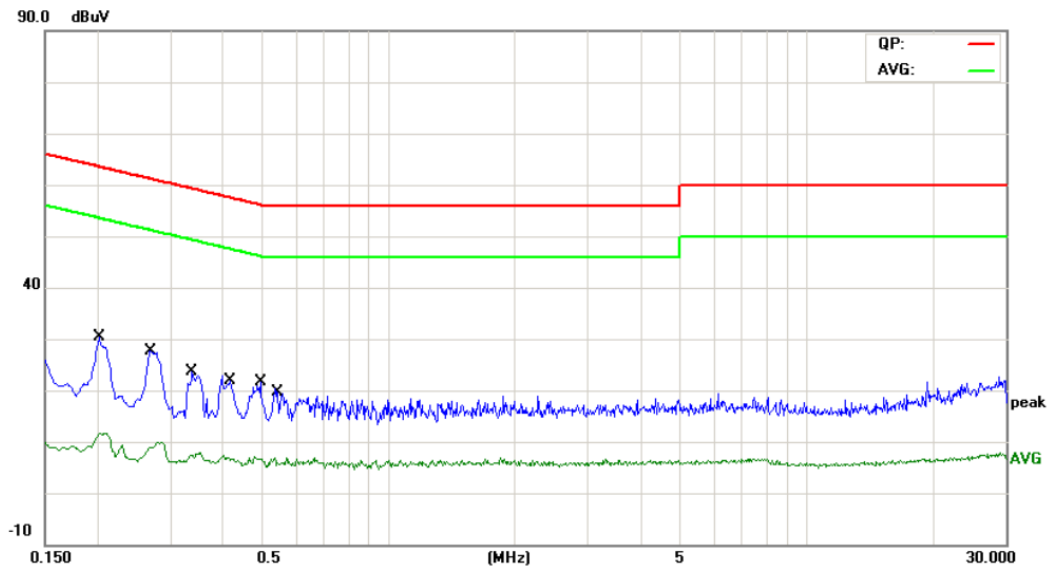

No.	Mk.	Freq.	Reading Level	Correct Factor	Measurement	Limit	Over	
		MHz	dBuV	dB	dBuV	dBuV	dB	Detector
1		0.2020	15.75	9.65	25.40	63.52	-38.12	QP
2		0.2020	0.56	9.65	10.21	53.52	-43.31	AVG
3	*	0.2700	13.48	9.59	23.07	61.12	-38.05	QP
4		0.2700	-1.27	9.59	8.32	51.12	-42.80	AVG
5		0.3379	8.36	9.57	17.93	59.25	-41.32	QP
6		0.3379	-2.98	9.57	6.59	49.25	-42.66	AVG
7		0.4180	6.04	9.58	15.62	57.49	-41.87	QP
8		0.4180	-3.94	9.58	5.64	47.49	-41.85	AVG
9		0.4940	4.61	9.58	14.19	56.10	-41.91	QP
10		0.4940	-3.91	9.58	5.67	46.10	-40.43	AVG
11		0.5420	2.31	9.58	11.89	56.00	-44.11	QP
12		0.5420	-4.65	9.58	4.93	46.00	-41.07	AVG

**Emission Level= Read Level+ Correct Factor**



<b>Temperature:</b>	25 °C	<b>Relative Humidity:</b>	55%
<b>Test Voltage:</b>	AC 240V/50Hz		
<b>Terminal:</b>	Line		
<b>Test Mode:</b>	Normal working with TX B Mode		
<b>Remark:</b>	Only worse case is reported		

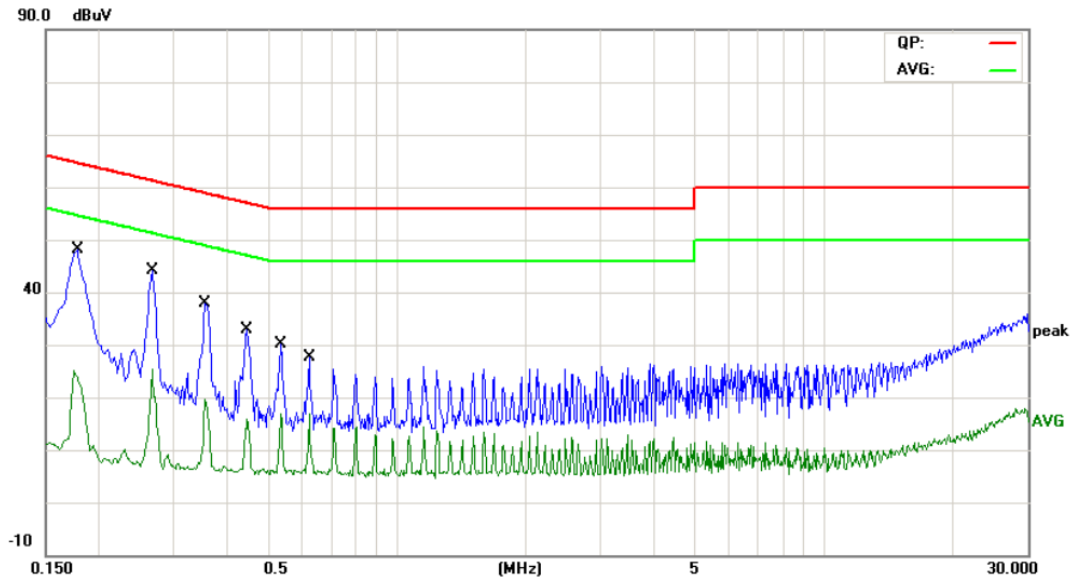

No.	Mk.	Freq.	Reading Level	Correct Factor	Measurement	Limit	Over	Detector
		MHz	dBuV	dB	dBuV	dBuV	dB	
1	*	0.1780	30.09	9.58	39.67	64.57	-24.90	QP
2		0.1780	11.89	9.58	21.47	54.57	-33.10	AVG
3		0.2660	25.19	9.59	34.78	61.24	-26.46	QP
4		0.2660	9.69	9.59	19.28	51.24	-31.96	AVG
5		0.3540	19.14	9.60	28.74	58.87	-30.13	QP
6		0.3540	5.97	9.60	15.57	48.87	-33.30	AVG
7		0.4460	12.04	9.60	21.64	56.95	-35.31	QP
8		0.4460	1.45	9.60	11.05	46.95	-35.90	AVG
9		0.5340	8.87	9.60	18.47	56.00	-37.53	QP
10		0.5340	1.85	9.60	11.45	46.00	-34.55	AVG
11		0.6220	8.81	9.61	18.42	56.00	-37.58	QP
12		0.6220	2.96	9.61	12.57	46.00	-33.43	AVG

**Emission Level= Read Level+ Correct Factor**



<b>Temperature:</b>	25 °C	<b>Relative Humidity:</b>	55%
<b>Test Voltage:</b>	AC 240V/50Hz		
<b>Terminal:</b>	Neutral		
<b>Test Mode:</b>	Normal working with TX B Mode		
<b>Remark:</b>	Only worse case is reported		

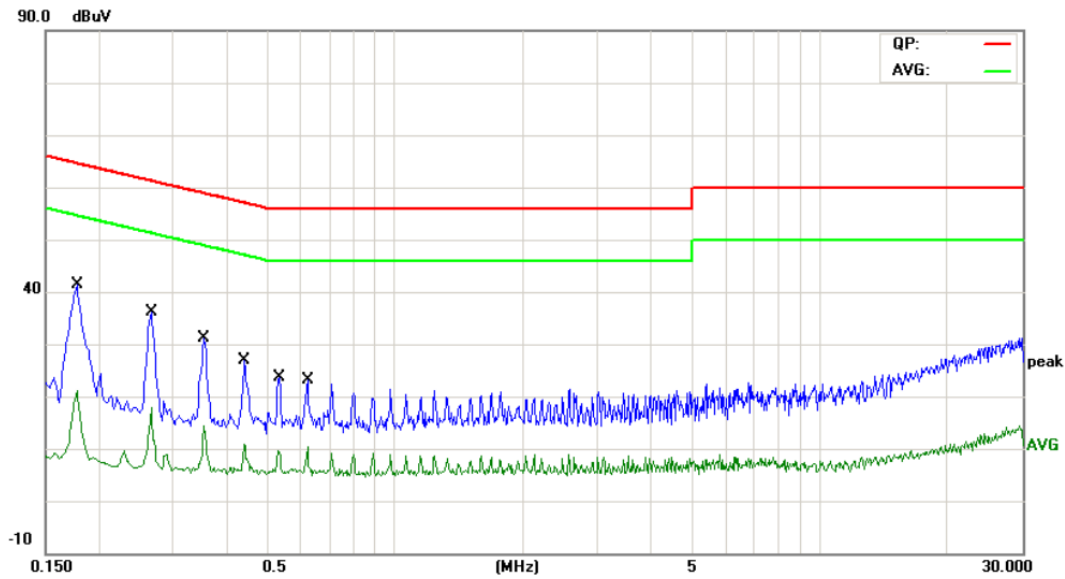

No.	Mk.	Freq.	Reading Level	Correct Factor	Measurement	Limit	Over	Detector
		MHz	dBuV	dB	dBuV	dBuV	dB	
1		0.1780	23.85	9.65	33.50	64.57	-31.07	QP
2		0.1780	6.32	9.65	15.97	54.57	-38.60	AVG
3	*	0.2660	20.91	9.60	30.51	61.24	-30.73	QP
4		0.2660	4.30	9.60	13.90	51.24	-37.34	AVG
5		0.3540	15.56	9.58	25.14	58.87	-33.73	QP
6		0.3540	1.49	9.58	11.07	48.87	-37.80	AVG
7		0.4420	10.80	9.58	20.38	57.02	-36.64	QP
8		0.4420	-1.10	9.58	8.48	47.02	-38.54	AVG
9		0.5340	5.73	9.58	15.31	56.00	-40.69	QP
10		0.5340	-2.88	9.58	6.70	46.00	-39.30	AVG
11		0.6220	6.31	9.59	15.90	56.00	-40.10	QP
12		0.6220	-2.49	9.59	7.10	46.00	-38.90	AVG

**Emission Level= Read Level+ Correct Factor**



The following 2# lamp board with Q9W test plot.

<b>Temperature:</b>	25 °C	<b>Relative Humidity:</b>	55%
<b>Test Voltage:</b>	AC 120V/60Hz		
<b>Terminal:</b>	Line		
<b>Test Mode:</b>	Normal working with TX B Mode		
<b>Remark:</b>	Only worse case is reported		

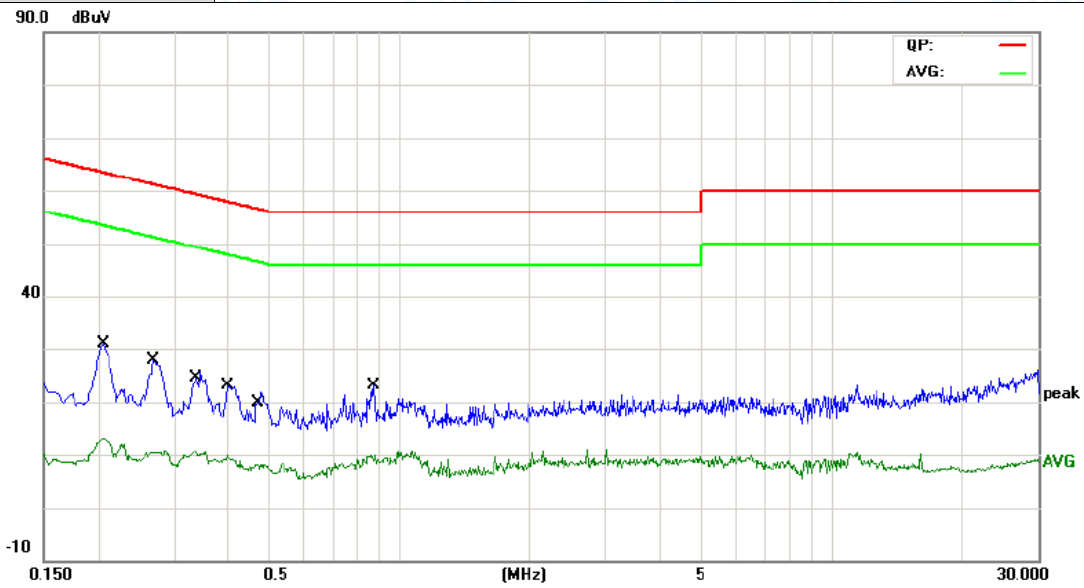

No.	Mk.	Freq.	Reading Level	Correct Factor	Measurement	Limit	Over	
		MHz	dBuV	dB	dBuV	dBuV	dB	Detector
1	*	0.2060	21.62	9.58	31.20	63.36	-32.16	QP
2		0.2060	3.64	9.58	13.22	53.36	-40.14	AVG
3		0.2700	18.23	9.59	27.82	61.12	-33.30	QP
4		0.2700	1.24	9.59	10.83	51.12	-40.29	AVG
5		0.3339	16.19	9.59	25.78	59.35	-33.57	QP
6		0.3339	1.12	9.59	10.71	49.35	-38.64	AVG
7		0.3980	13.64	9.60	23.24	57.89	-34.65	QP
8		0.3980	0.26	9.60	9.86	47.89	-38.03	AVG
9		0.4660	12.29	9.60	21.89	56.58	-34.69	QP
10		0.4660	-1.40	9.60	8.20	46.58	-38.38	AVG
11		0.8700	13.56	9.60	23.16	56.00	-32.84	QP
12		0.8780	0.33	9.60	9.93	46.00	-36.07	AVG

**Emission Level= Read Level+ Correct Factor**



<b>Temperature:</b>	25 °C	<b>Relative Humidity:</b>	55%
<b>Test Voltage:</b>	AC 120V/60Hz		
<b>Terminal:</b>	Neutral		
<b>Test Mode:</b>	Normal working with TX B Mode		
<b>Remark:</b>	Only worse case is reported		

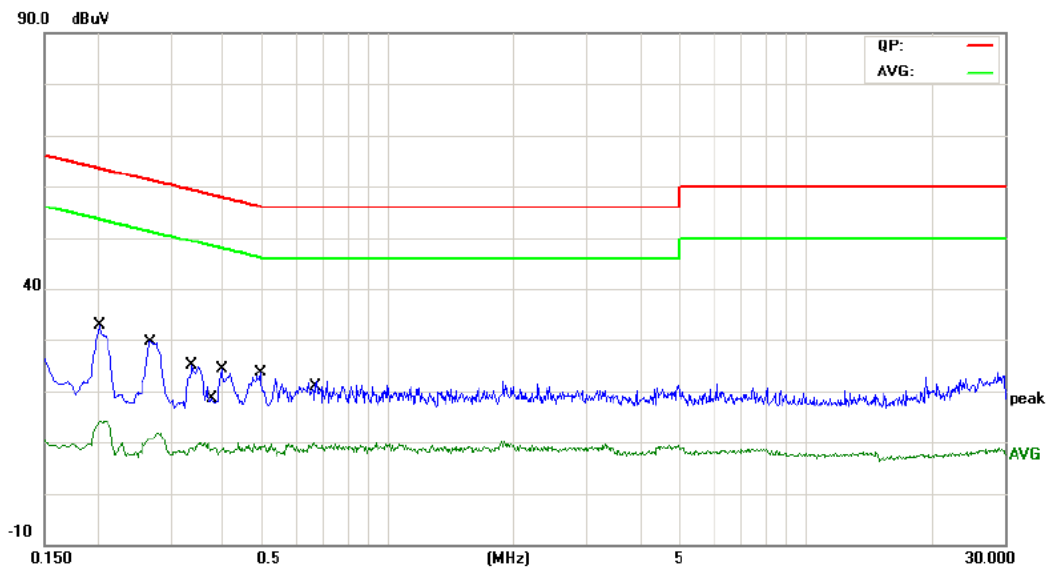

No.	Mk.	Freq.	Reading Level	Correct Factor	Measurement	Limit	Over	
		MHz	dBuV	dB	dBuV	dBuV	dB	Detector
1	*	0.2020	23.20	9.65	32.85	63.52	-30.67	QP
2		0.2020	4.58	9.65	14.23	53.52	-39.29	AVG
3		0.2700	20.06	9.59	29.65	61.12	-31.47	QP
4		0.2700	2.38	9.59	11.97	51.12	-39.15	AVG
5		0.3379	15.61	9.57	25.18	59.25	-34.07	QP
6		0.3379	0.33	9.57	9.90	49.25	-39.35	AVG
7		0.3780	0.24	9.58	9.82	48.32	-38.50	AVG
8		0.3980	14.69	9.58	24.27	57.89	-33.62	QP
9		0.4940	14.06	9.58	23.64	56.10	-32.46	QP
10		0.4940	0.00	9.58	9.58	46.10	-36.52	AVG
11		0.6620	12.20	9.59	21.79	56.00	-34.21	QP
12		0.6620	0.21	9.59	9.80	46.00	-36.20	AVG

**Emission Level= Read Level+ Correct Factor**



<b>Temperature:</b>	25 °C	<b>Relative Humidity:</b>	55%
<b>Test Voltage:</b>	AC 240V/50Hz		
<b>Terminal:</b>	Line		
<b>Test Mode:</b>	Normal working with TX B Mode		
<b>Remark:</b>	Only worse case is reported		

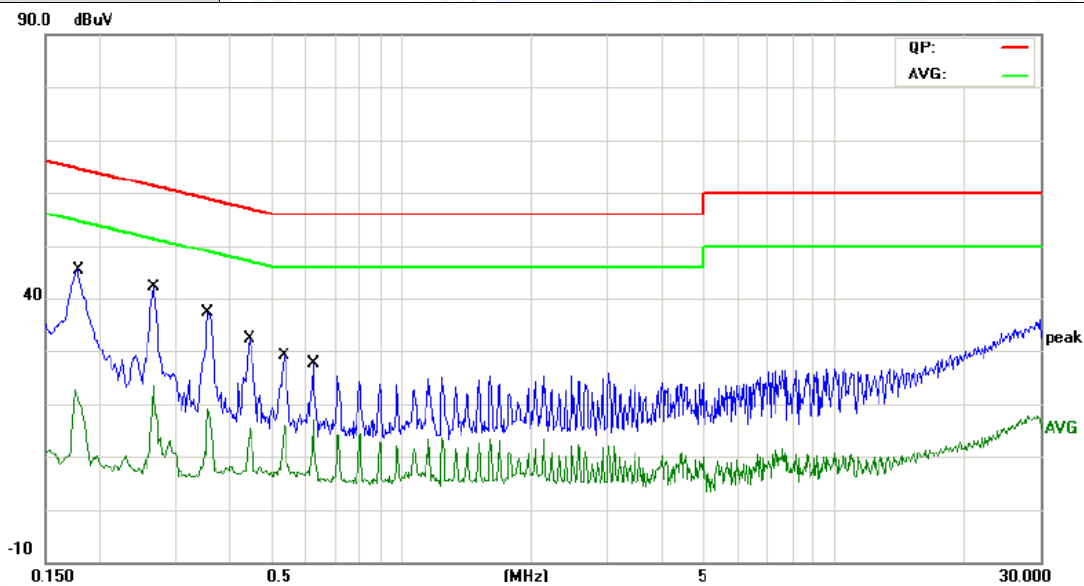

No.	Mk.	Freq. MHz	Reading Level dBuV	Correct Factor dB	Measure- ment dBuV	Limit dBuV	Over dB	Detector
1		0.1739	36.00	9.58	45.58	64.77	-19.19	QP
2		0.1739	13.05	9.58	22.63	54.77	-32.14	AVG
3	*	0.2660	32.62	9.59	42.21	61.24	-19.03	QP
4		0.2660	13.78	9.59	23.37	51.24	-27.87	AVG
5		0.3539	27.72	9.60	37.32	58.87	-21.55	QP
6		0.3539	9.49	9.60	19.09	48.87	-29.78	AVG
7		0.4460	22.89	9.60	32.49	56.95	-24.46	QP
8		0.4460	5.83	9.60	15.43	46.95	-31.52	AVG
9		0.5340	19.48	9.60	29.08	56.00	-26.92	QP
10		0.5340	6.18	9.60	15.78	46.00	-30.22	AVG
11		0.6219	18.07	9.61	27.68	56.00	-28.32	QP
12		0.6219	7.37	9.61	16.98	46.00	-29.02	AVG

**Emission Level= Read Level+ Correct Factor**



<b>Temperature:</b>	25 °C	<b>Relative Humidity:</b>	55%
<b>Test Voltage:</b>	AC 240V/50Hz		
<b>Terminal:</b>	Neutral		
<b>Test Mode:</b>	Normal working with TX B Mode		
<b>Remark:</b>	Only worse case is reported		

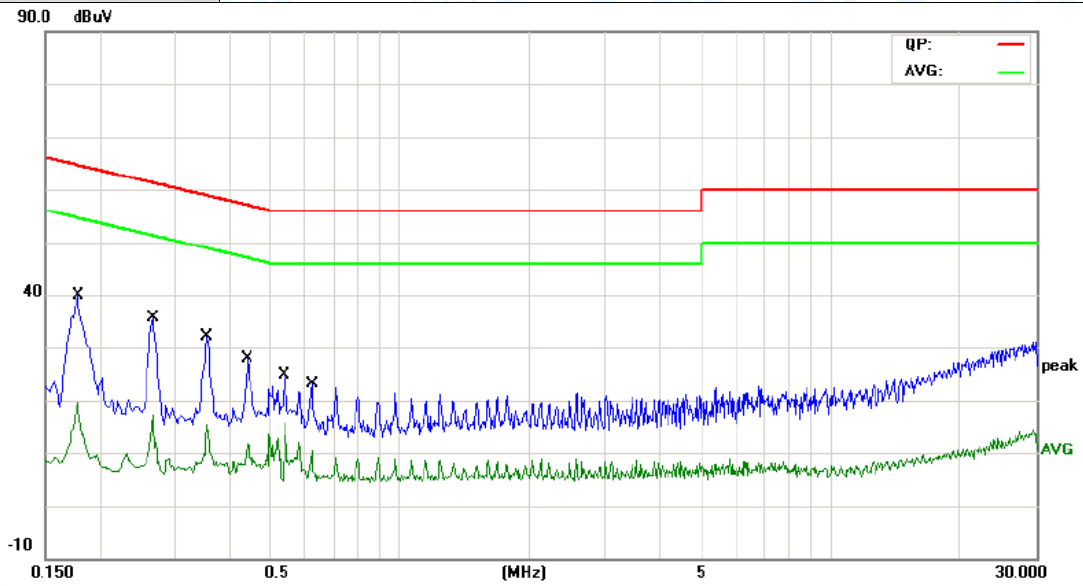

No.	Mk.	Freq.	Reading Level	Correct Factor	Measurement	Limit	Over	
		MHz	dBuV	dB	dBuV	dBuV	dB	Detector
1	*	0.1779	30.22	9.65	39.87	64.58	-24.71	QP
2		0.1779	9.86	9.65	19.51	54.58	-35.07	AVG
3		0.2660	26.14	9.60	35.74	61.24	-25.50	QP
4		0.2660	7.87	9.60	17.47	51.24	-33.77	AVG
5		0.3539	22.51	9.58	32.09	58.87	-26.78	QP
6		0.3539	5.92	9.58	15.50	48.87	-33.37	AVG
7		0.4420	18.32	9.58	27.90	57.02	-29.12	QP
8		0.4420	2.18	9.58	11.76	47.02	-35.26	AVG
9		0.5349	15.22	9.58	24.80	56.00	-31.20	QP
10		0.5349	6.04	9.58	15.62	46.00	-30.38	AVG
11		0.6219	13.45	9.59	23.04	56.00	-32.96	QP
12		0.6219	0.74	9.59	10.33	46.00	-35.67	AVG

**Emission Level= Read Level+ Correct Factor**



The following 3# lamp board with Q9W test plot.

<b>Temperature:</b>	25 °C	<b>Relative Humidity:</b>	55%
<b>Test Voltage:</b>	AC 120V/60Hz		
<b>Terminal:</b>	Line		
<b>Test Mode:</b>	Normal working with TX B Mode		
<b>Remark:</b>	Only worse case is reported		

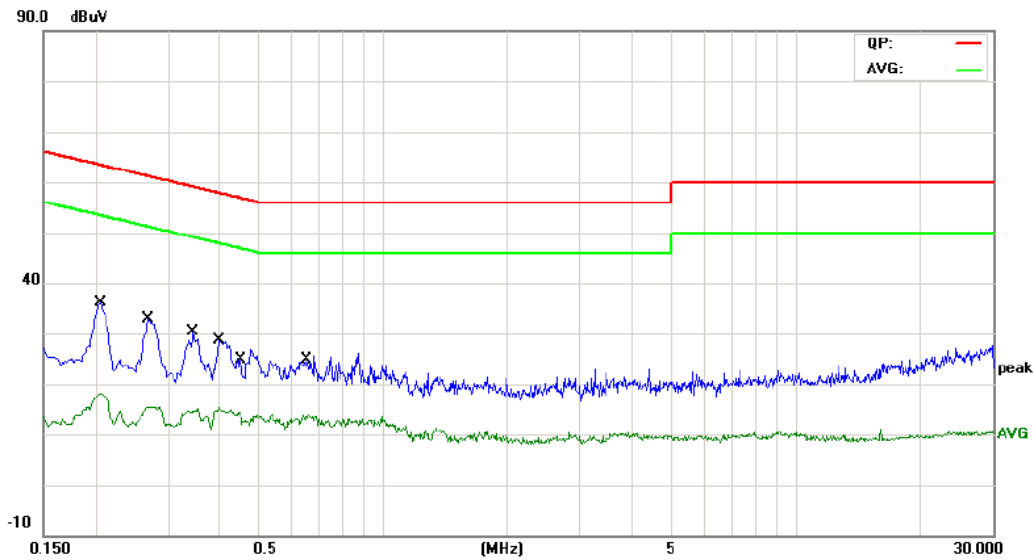

No.	Mk.	Freq. MHz	Reading Level dBuV	Correct Factor dB	Measure- ment dBuV	Limit dBuV	Over dB	Detector
1	*	0.2060	26.62	9.58	36.20	63.36	-27.16	QP
2		0.2060	8.64	9.58	18.22	53.36	-35.14	AVG
3		0.2700	23.23	9.59	32.82	61.12	-28.30	QP
4		0.2700	5.83	9.59	15.42	51.12	-35.70	AVG
5		0.3460	20.69	9.59	30.28	59.06	-28.78	QP
6		0.3460	5.41	9.59	15.00	49.06	-34.06	AVG
7		0.3980	19.14	9.60	28.74	57.89	-29.15	QP
8		0.3980	5.76	9.60	15.36	47.89	-32.53	AVG
9		0.4500	17.29	9.60	26.89	56.87	-29.98	QP
10		0.4500	4.88	9.60	14.48	46.87	-32.39	AVG
11		0.6580	15.94	9.61	25.55	56.00	-30.45	QP
12		0.6580	4.32	9.61	13.93	46.00	-32.07	AVG

**Emission Level= Read Level+ Correct Factor**



<b>Temperature:</b>	25 °C	<b>Relative Humidity:</b>	55%
<b>Test Voltage:</b>	AC 120V/60Hz		
<b>Terminal:</b>	Neutral		
<b>Test Mode:</b>	Normal working with TX B Mode		
<b>Remark:</b>	Only worse case is reported		

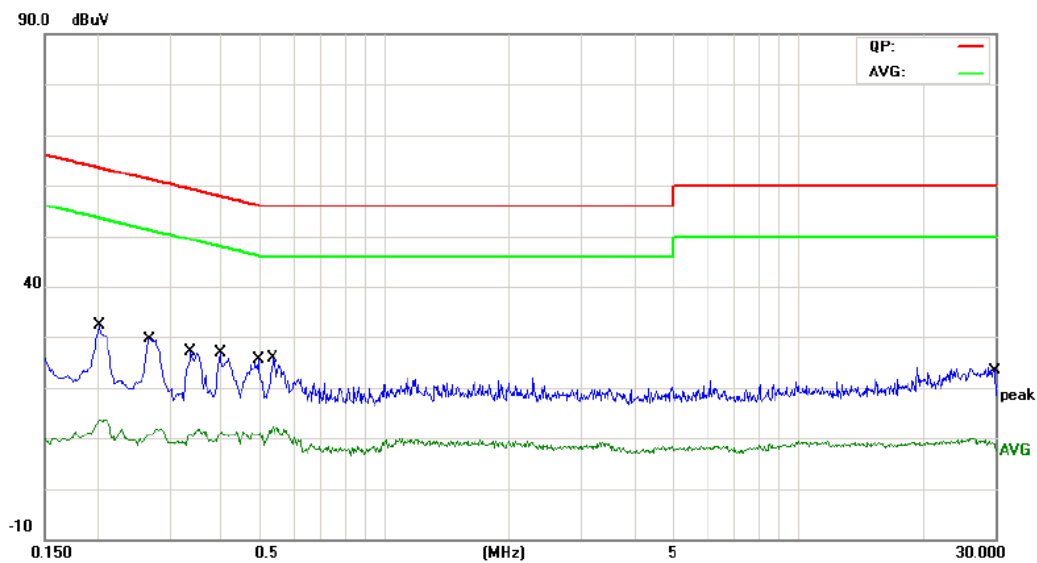

No.	Mk.	Freq. MHz	Reading Level dBuV	Correct Factor dB	Measure- ment dBuV	Limit dBuV	Over dB	Detector
1		0.2020	22.70	9.65	32.35	63.52	-31.17	QP
2		0.2020	4.08	9.65	13.73	53.52	-39.79	AVG
3		0.2700	20.06	9.59	29.65	61.12	-31.47	QP
4		0.2700	2.38	9.59	11.97	51.12	-39.15	AVG
5		0.3379	17.61	9.57	27.18	59.25	-32.07	QP
6		0.3379	2.33	9.57	11.90	49.25	-37.35	AVG
7		0.3980	17.19	9.58	26.77	57.89	-31.12	QP
8		0.3980	1.71	9.58	11.29	47.89	-36.60	AVG
9		0.4940	16.06	9.58	25.64	56.10	-30.46	QP
10		0.4940	2.00	9.58	11.58	46.10	-34.52	AVG
11		0.5340	16.24	9.58	25.82	56.00	-30.18	QP
12		0.5340	11.77	9.58	11.77	46.00	-34.23	AVG

**Emission Level= Read Level+ Correct Factor**



<b>Temperature:</b>	25 °C	<b>Relative Humidity:</b>	55%
<b>Test Voltage:</b>	AC 240V/50Hz		
<b>Terminal:</b>	Line		
<b>Test Mode:</b>	Normal working with TX B Mode		
<b>Remark:</b>	Only worse case is reported		

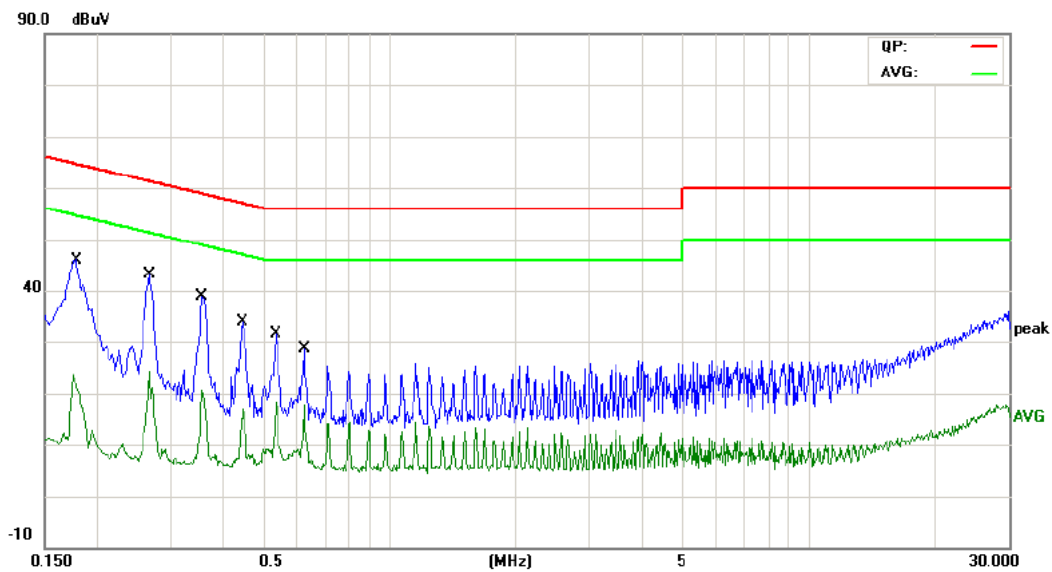

No.	Mk.	Freq. MHz	Reading Level dBuV	Correct Factor dB	Measure- ment dBuV	Limit dBuV	Over dB	Detector
1		0.1739	36.50	9.58	46.08	64.77	-18.69	QP
2		0.1739	14.05	9.58	23.63	54.77	-31.14	AVG
3	*	0.2660	33.62	9.59	43.21	61.24	-18.03	QP
4		0.2660	14.78	9.59	24.37	51.24	-26.87	AVG
5		0.3539	29.22	9.60	38.82	58.87	-20.05	QP
6		0.3539	10.99	9.60	20.59	48.87	-28.28	AVG
7		0.4460	24.39	9.60	33.99	56.95	-22.96	QP
8		0.4460	7.33	9.60	16.93	46.95	-30.02	AVG
9		0.5340	21.98	9.60	31.58	56.00	-24.42	QP
10		0.5340	8.68	9.60	18.28	46.00	-27.72	AVG
11		0.6219	19.07	9.61	28.68	56.00	-27.32	QP
12		0.6219	4.73	9.61	14.34	46.00	-31.66	AVG

**Emission Level= Read Level+ Correct Factor**

<b>Temperature:</b>	25 °C	<b>Relative Humidity:</b>	55%
<b>Test Voltage:</b>	AC 240V/50Hz		
<b>Terminal:</b>	Neutral		
<b>Test Mode:</b>	Normal working with TX B Mode		
<b>Remark:</b>	Only worse case is reported		

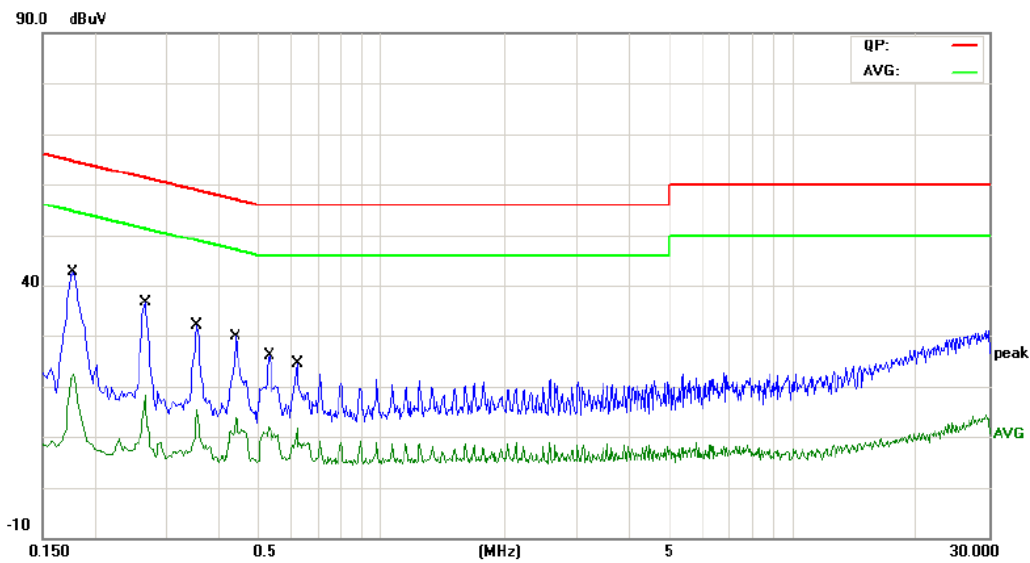

No.	Mk.	Freq.	Reading Level	Correct Factor	Measurement	Limit	Over	Detector
		MHz	dBuV	dB	dBuV	dBuV	dB	
1	*	0.1766	32.98	9.65	42.63	64.64	-22.01	QP
2		0.1766	12.71	9.65	22.36	54.64	-32.28	AVG
3		0.2660	27.14	9.60	36.74	61.24	-24.50	QP
4		0.2660	8.87	9.60	18.47	51.24	-32.77	AVG
5		0.3539	22.51	9.58	32.09	58.87	-26.78	QP
6		0.3539	5.92	9.58	15.50	48.87	-33.37	AVG
7		0.4420	20.32	9.58	29.90	57.02	-27.12	QP
8		0.4420	4.18	9.58	13.76	47.02	-33.26	AVG
9		0.5340	16.47	9.58	26.05	56.00	-29.95	QP
10		0.5340	1.14	9.58	10.72	46.00	-35.28	AVG
11		0.6219	14.95	9.59	24.54	56.00	-31.46	QP
12		0.6219	2.24	9.59	11.83	46.00	-34.17	AVG

**Emission Level= Read Level+ Correct Factor**



## Attachment B-- Radiated Emission Test Data

### 9KHz~30MHz

From 9KHz to 30MHz: Conclusion: PASS

Note: The amplitude of spurious emissions which are attenuated by more than 20dB below the permissible value has no need to be reported.

### 30MHz~1GHz

The following Q9W test plot.

<b>Temperature:</b>	25 °C	<b>Relative Humidity:</b>	55%
<b>Test Voltage:</b>	AC 120V/60HZ		
<b>Ant. Pol.</b>	Horizontal		
<b>Test Mode:</b>	TX B Mode 2412MHz		
<b>Remark:</b>	Only worse case is reported		

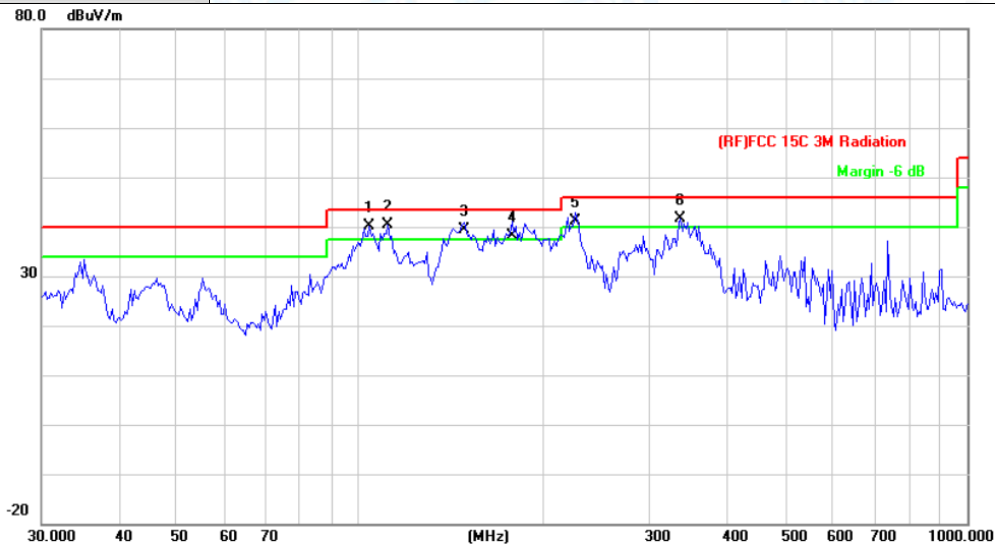

No.	Mk.	Freq.	Reading Level	Correct Factor	Measurement	Limit	Over	
		MHz	dBuV	dB/m	dBuV/m	dBuV/m	dB	Detector
1	!	103.8055	62.29	-22.23	40.06	43.50	-3.44	QP
2	*	111.3468	62.81	-22.42	40.39	43.50	-3.11	QP
3	!	148.4410	61.00	-21.60	39.40	43.50	-4.10	QP
4	!	178.1327	58.34	-20.24	38.10	43.50	-5.40	QP
5	!	226.0994	59.61	-18.51	41.10	46.00	-4.90	QP
6	!	337.2155	56.61	-14.99	41.62	46.00	-4.38	QP

\*:Maximum data    x:Over limit    !:over margin

**Emission Level= Read Level+ Correct Factor**

<b>Temperature:</b>	25 °C	<b>Relative Humidity:</b>	55%
<b>Test Voltage:</b>	AC 120V/60HZ		
<b>Ant. Pol.</b>	Vertical		
<b>Test Mode:</b>	TX B Mode 2412MHz		
<b>Remark:</b>	Only worse case is reported		

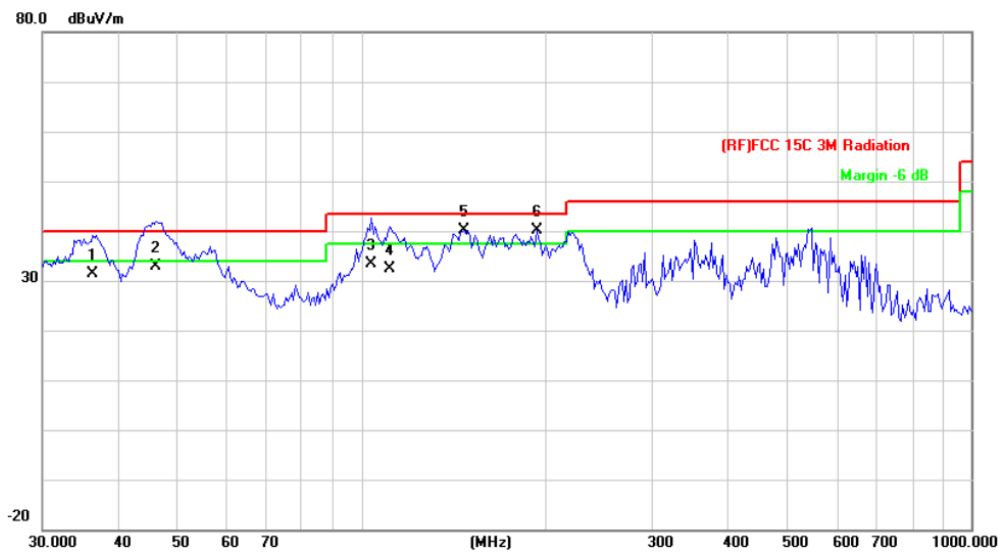

No.	Mk.	Freq.	Reading Level	Correct Factor	Measurement	Limit	Over	Detector
		MHz	dBuV	dB/m	dBuV/m	dBuV/m	dB	
1		36.2541	48.84	-17.34	31.50	40.00	-8.50	QP
2		46.0162	54.72	-21.92	32.80	40.00	-7.20	QP
3		103.8054	55.63	-22.23	33.40	43.50	-10.10	QP
4		111.3468	54.92	-22.42	32.50	43.50	-11.00	QP
5	*	147.4036	61.81	-21.71	40.10	43.50	-3.40	QP
6	!	193.7727	59.92	-19.87	40.05	43.50	-3.45	QP

\*:Maximum data    x:Over limit    !:over margin

**Emission Level= Read Level+ Correct Factor**



The following Q9T test plot.

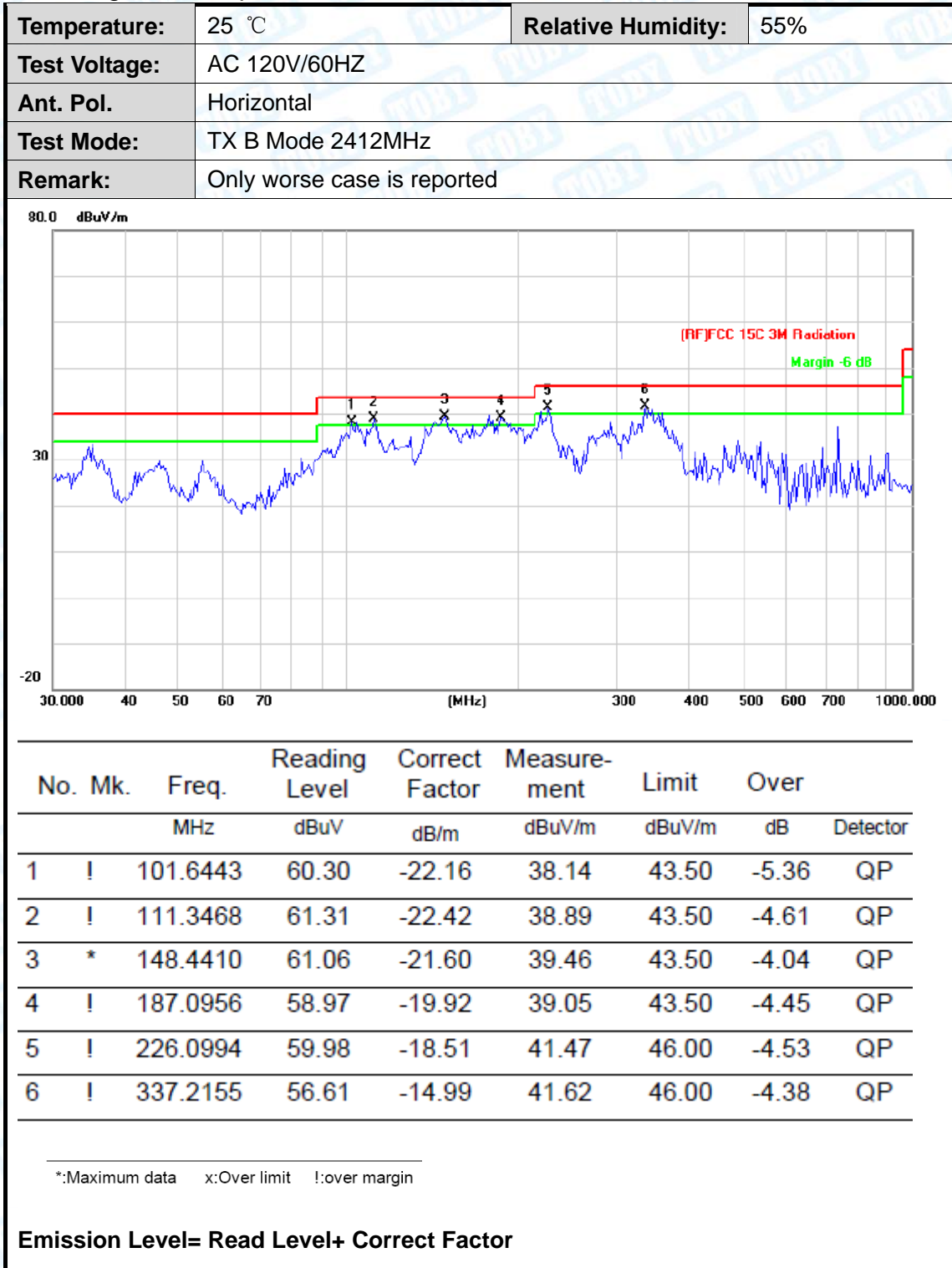

<b>Temperature:</b>	25 °C	<b>Relative Humidity:</b>	55%
<b>Test Voltage:</b>	AC 120V/60HZ		
<b>Ant. Pol.</b>	Vertical		
<b>Test Mode:</b>	TX B Mode 2412MHz		
<b>Remark:</b>	Only worse case is reported		

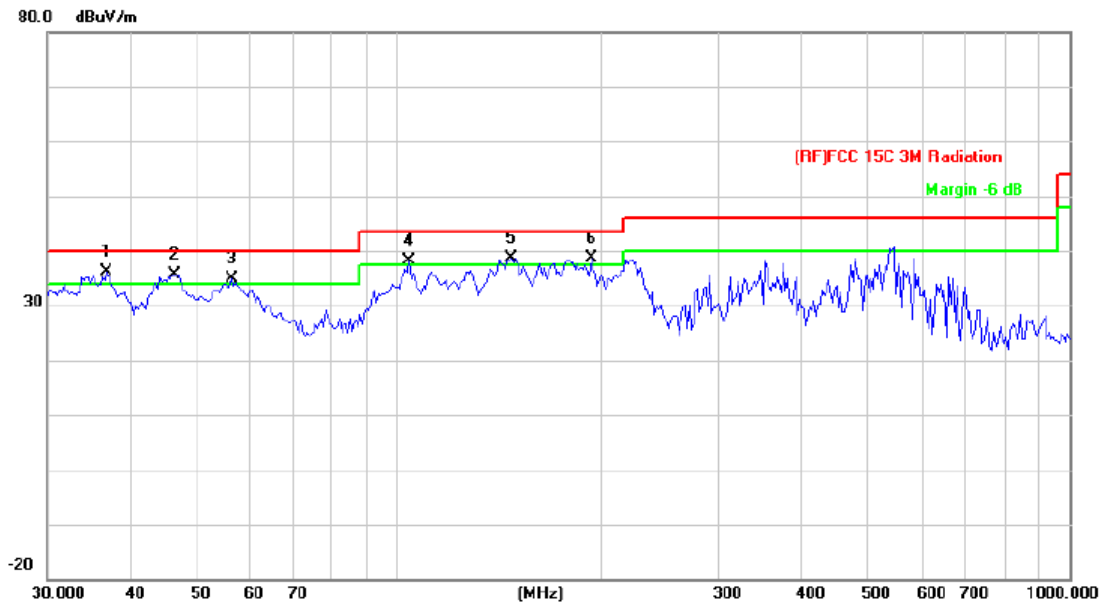

No.	Mk.	Freq. MHz	Reading Level dBuV	Correct Factor dB/m	Measure- ment dBuV/m	Limit dBuV/m	Over dB	Detector
1	*	36.7661	53.63	-17.59	36.04	40.00	-3.96	QP
2	!	46.3402	57.64	-22.03	35.61	40.00	-4.39	QP
3	!	56.3947	58.89	-23.97	34.92	40.00	-5.08	QP
4	!	103.8054	60.47	-22.23	38.24	43.50	-5.26	QP
5	!	147.4036	60.31	-21.71	38.60	43.50	-4.90	QP
6	!	193.7726	58.42	-19.87	38.55	43.50	-4.95	QP

\*:Maximum data    x:Over limit    !:over margin

**Emission Level= Read Level+ Correct Factor**



The following another lamp board with Q9W test plot.

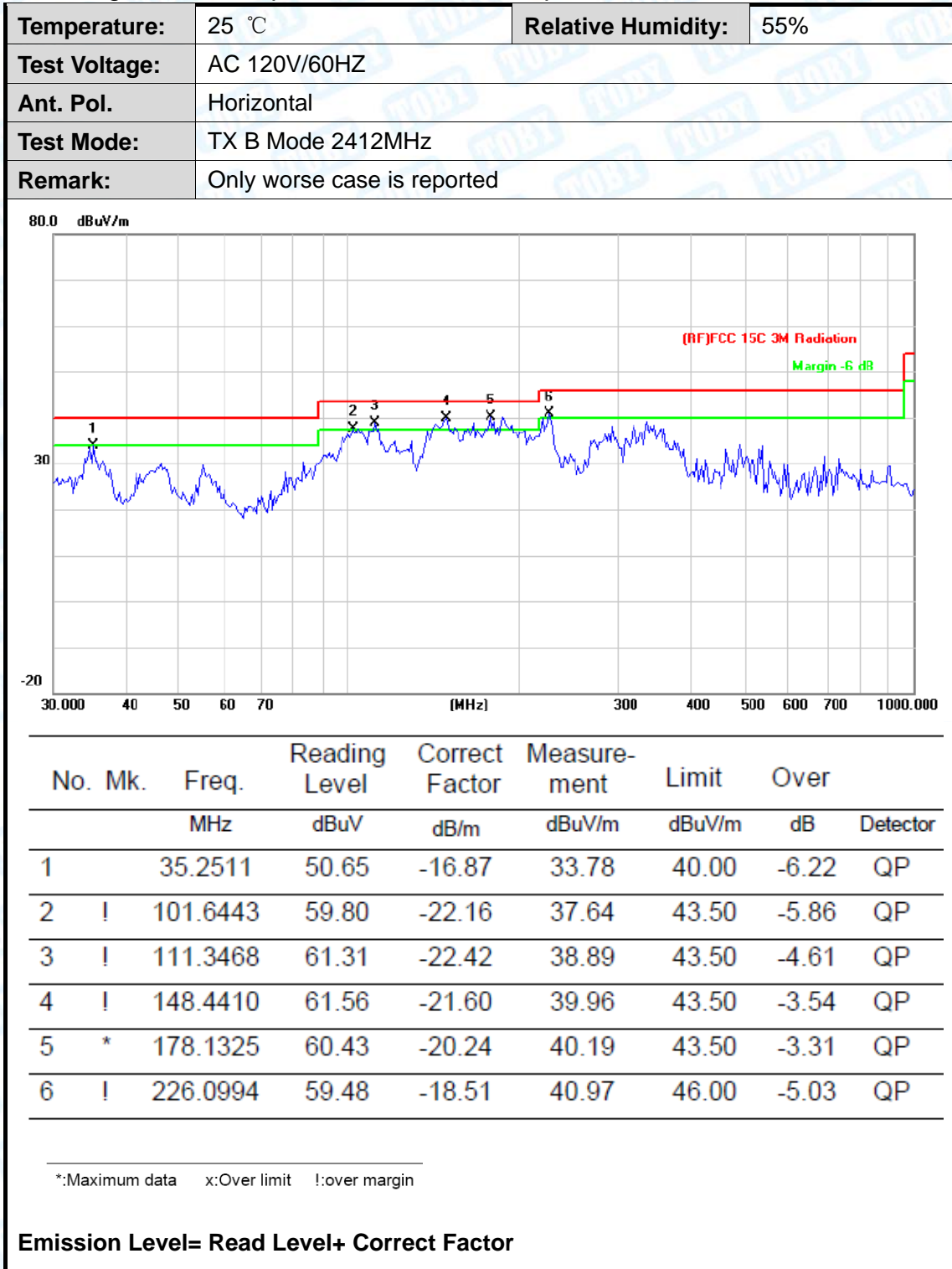

<b>Temperature:</b>	25 °C	<b>Relative Humidity:</b>	55%
<b>Test Voltage:</b>	AC 120V/60HZ		
<b>Ant. Pol.</b>	Vertical		
<b>Test Mode:</b>	TX B Mode 2412MHz		
<b>Remark:</b>	Only worse case is reported		

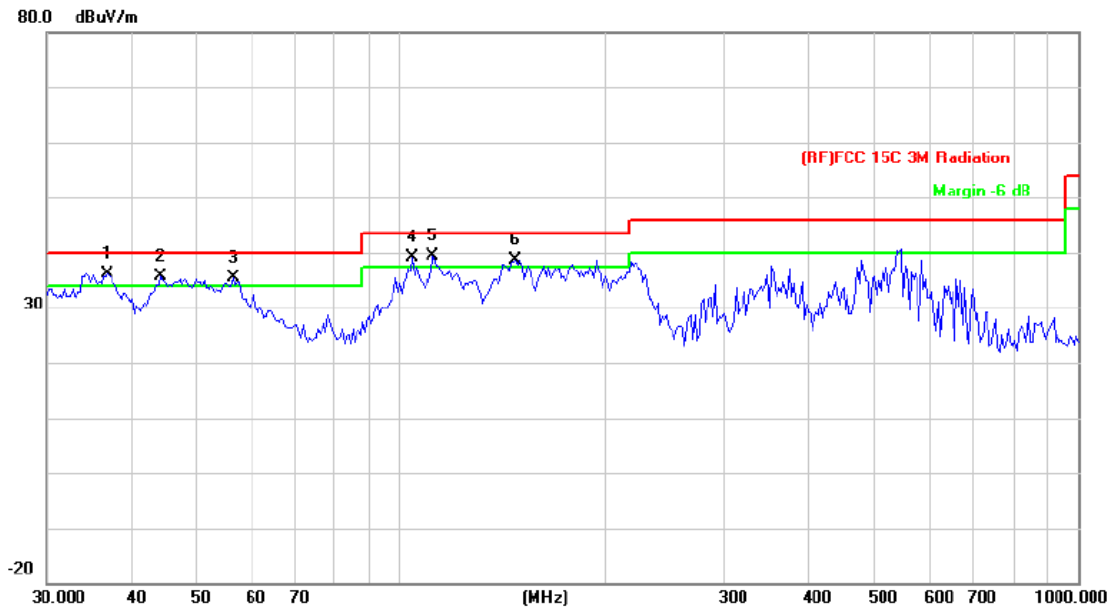

No.	Mk.	Freq. MHz	Reading Level dBuV	Correct Factor dB/m	Measure- ment dBuV/m	Limit dBuV/m	Over dB	Detector
1	*	36.7661	53.63	-17.59	36.04	40.00	-3.96	QP
2	!	44.1200	56.87	-21.14	35.73	40.00	-4.27	QP
3	!	56.3947	59.39	-23.97	35.42	40.00	-4.58	QP
4	!	103.8054	61.47	-22.23	39.24	43.50	-4.26	QP
5	!	111.3468	61.88	-22.42	39.46	43.50	-4.04	QP
6	!	147.4036	60.31	-21.71	38.60	43.50	-4.90	QP

\*:Maximum data    x:Over limit    !:over margin

**Emission Level= Read Level+ Correct Factor**



**Above 1GHz**

<b>Temperature:</b>	25 °C	<b>Relative Humidity:</b>	55%
<b>Test Voltage:</b>	AC 120V/60HZ		
<b>Ant. Pol.</b>	Horizontal		
<b>Test Mode:</b>	TX B Mode 2412MHz		
<b>Remark:</b>	No report for the emission which more than 10 dB below the prescribed limit.		

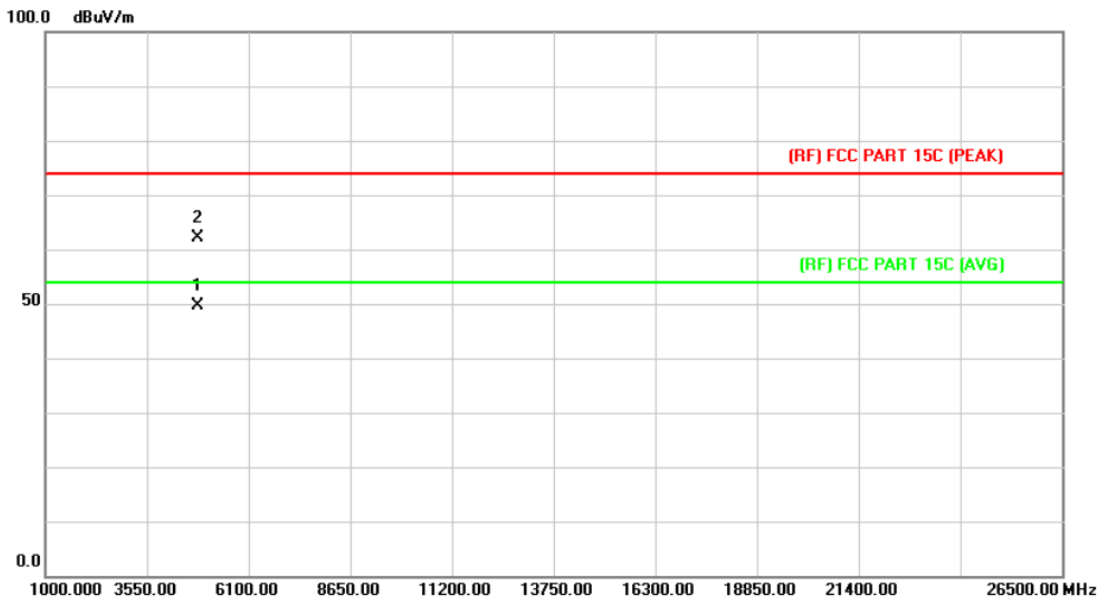

No.	Mk.	Freq.	Reading Level	Correct Factor	Measurement	Limit	Over	Detector
		MHz	dBuV	dB/m	dBuV/m	dBuV/m	dB	
1	*	4823.988	35.03	14.55	49.58	54.00	-4.42	AVG
2		4824.018	47.60	14.55	62.15	74.00	-11.85	peak

**Emission Level= Read Level+ Correct Factor**

<b>Temperature:</b>	25 °C	<b>Relative Humidity:</b>	55%
<b>Test Voltage:</b>	AC 120V/60HZ		
<b>Ant. Pol.</b>	Vertical		
<b>Test Mode:</b>	TX B Mode 2412MHz		
<b>Remark:</b>	No report for the emission which more than 10 dB below the prescribed limit.		

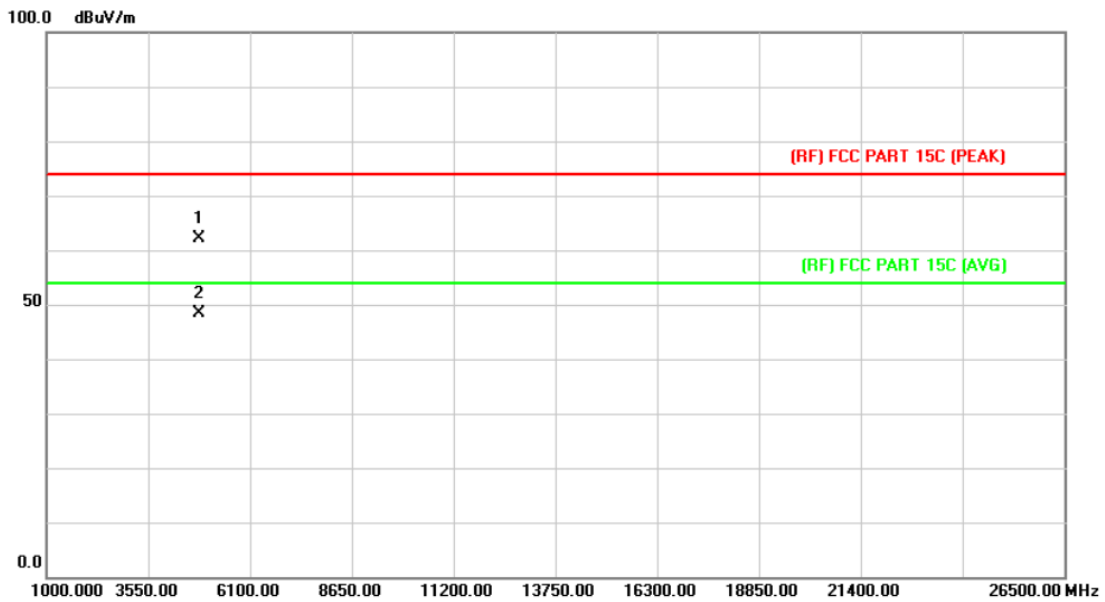

No.	Mk.	Freq.	Reading Level	Correct Factor	Measurement	Limit	Over	
		MHz	dBuV	dB/m	dBuV/m	dBuV/m	dB	Detector
1		4823.832	47.60	14.55	62.15	74.00	-11.85	peak
2	*	4824.012	33.71	14.55	48.26	54.00	-5.74	AVG

**Emission Level= Read Level+ Correct Factor**



<b>Temperature:</b>	25 °C	<b>Relative Humidity:</b>	55%
<b>Test Voltage:</b>	AC 120V/60HZ		
<b>Ant. Pol.</b>	Horizontal		
<b>Test Mode:</b>	TX B Mode 2437MHz		
<b>Remark:</b>	No report for the emission which more than 10 dB below the prescribed limit.		

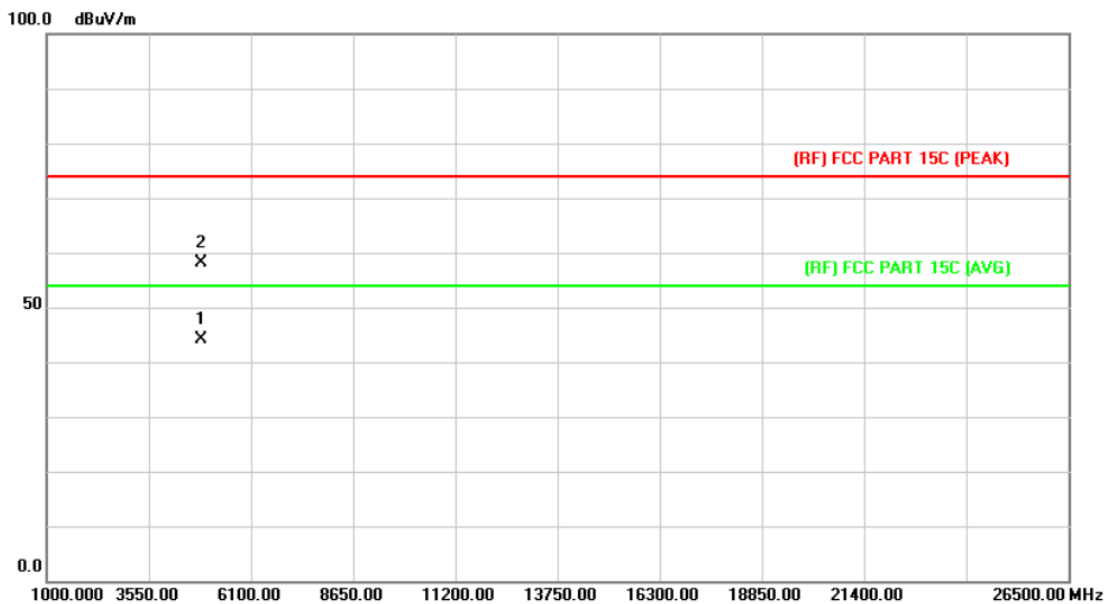

No.	Mk.	Freq.	Reading Level	Correct Factor	Measurement	Limit	Over	Detector
		MHz	dBuV	dB/m	dBuV/m	dBuV/m	dB	
1	*	4874.864	29.26	14.86	44.12	54.00	-9.88	AVG
2		4874.936	43.29	14.86	58.15	74.00	-15.85	peak

**Emission Level= Read Level+ Correct Factor**

<b>Temperature:</b>	25 °C	<b>Relative Humidity:</b>	55%
<b>Test Voltage:</b>	AC 120V/60HZ		
<b>Ant. Pol.</b>	Vertical		
<b>Test Mode:</b>	TX B Mode 2437MHz		
<b>Remark:</b>	No report for the emission which more than 10 dB below the prescribed limit.		

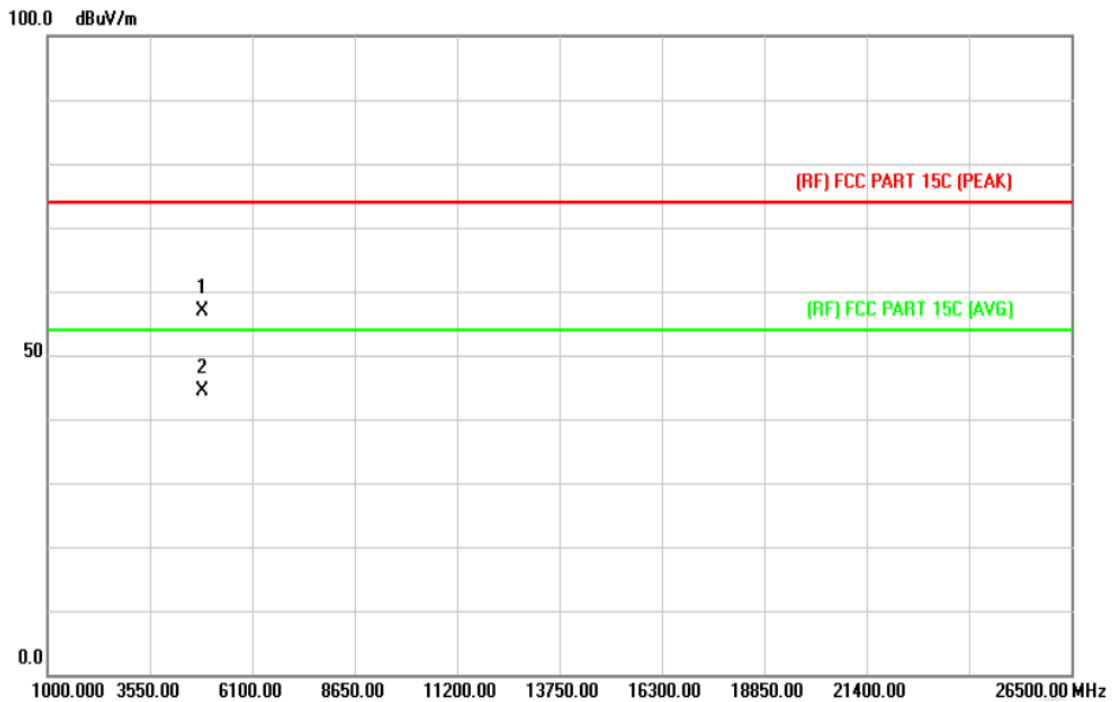

No.	Mk.	Freq. MHz	Reading Level dBuV	Correct Factor dB/m	Measure- ment dBuV/m	Limit dBuV/m	Over dB	Detector
1		4873.490	41.99	14.86	56.85	74.00	-17.15	peak
2	*	4874.888	29.40	14.86	44.26	54.00	-9.74	AVG

**Emission Level= Read Level+ Correct Factor**



<b>Temperature:</b>	25 °C	<b>Relative Humidity:</b>	55%
<b>Test Voltage:</b>	AC 120V/60HZ		
<b>Ant. Pol.</b>	Horizontal		
<b>Test Mode:</b>	TX B Mode 2462MHz		
<b>Remark:</b>	No report for the emission which more than 10 dB below the prescribed limit.		

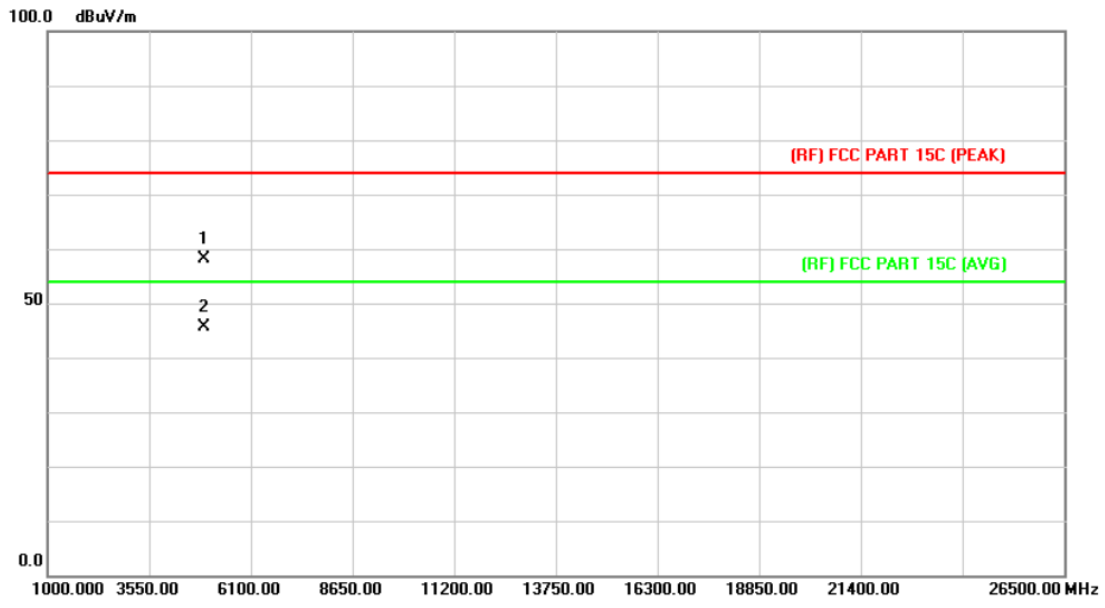

No.	Mk.	Freq. MHz	Reading Level dBuV	Correct Factor dB/m	Measure- ment dBuV/m	Limit dBuV/m	Over dB	Detector
1		4925.170	43.00	15.19	58.19	74.00	-15.81	peak
2	*	4925.362	30.37	15.19	45.56	54.00	-8.44	AVG

**Emission Level= Read Level+ Correct Factor**

<b>Temperature:</b>	25 °C	<b>Relative Humidity:</b>	55%
<b>Test Voltage:</b>	AC 120V/60HZ		
<b>Ant. Pol.</b>	Vertical		
<b>Test Mode:</b>	TX B Mode 2462MHz		
<b>Remark:</b>	No report for the emission which more than 10 dB below the prescribed limit.		

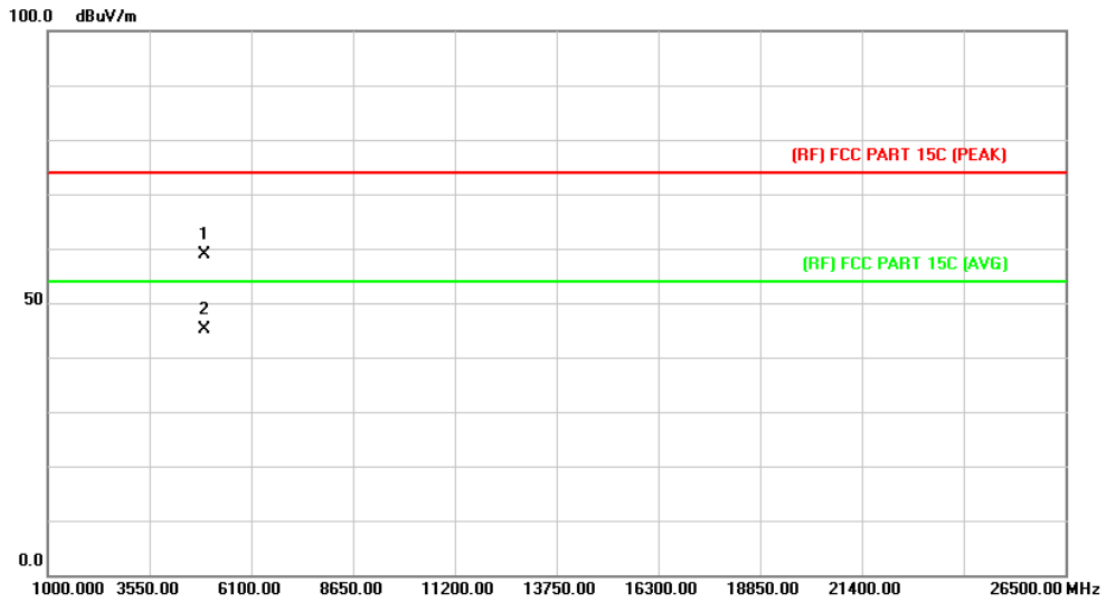

No.	Mk.	Freq.	Reading Level	Correct Factor	Measurement	Limit	Over	Detector
		MHz	dBuV	dB/m	dBuV/m	dBuV/m	dB	
1		4924.528	43.68	15.17	58.85	74.00	-15.15	peak
2	*	4925.104	29.95	15.19	45.14	54.00	-8.86	AVG

**Emission Level= Read Level+ Correct Factor**



<b>Temperature:</b>	25 °C	<b>Relative Humidity:</b>	55%
<b>Test Voltage:</b>	AC 120V/60HZ		
<b>Ant. Pol.</b>	Horizontal		
<b>Test Mode:</b>	TX G Mode 2412MHz		
<b>Remark:</b>	No report for the emission which more than 10 dB below the prescribed limit.		

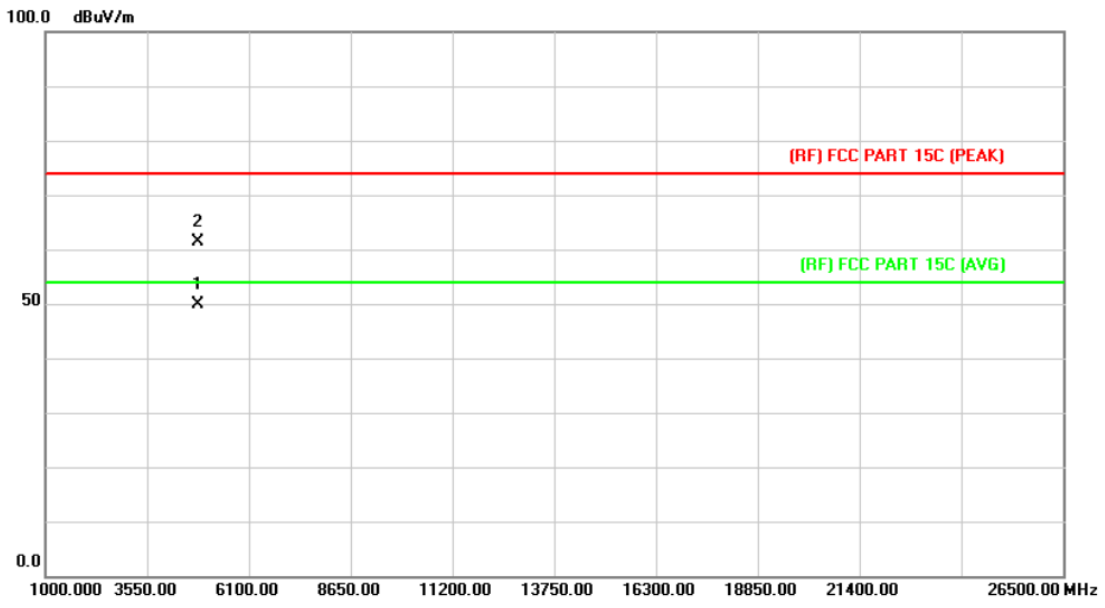

No.	Mk.	Freq.	Reading Level	Correct Factor	Measurement	Limit	Over	Detector
		MHz	dBuV	dB/m	dBuV/m	dBuV/m	dB	
1	*	4824.012	35.34	14.55	49.89	54.00	-4.11	AVG
2		4824.318	46.90	14.55	61.45	74.00	-12.55	peak

**Emission Level= Read Level+ Correct Factor**

<b>Temperature:</b>	25 °C	<b>Relative Humidity:</b>	55%
<b>Test Voltage:</b>	AC 120V/60HZ		
<b>Ant. Pol.</b>	Vertical		
<b>Test Mode:</b>	TX G Mode 2412MHz		
<b>Remark:</b>	No report for the emission which more than 10 dB below the prescribed limit.		

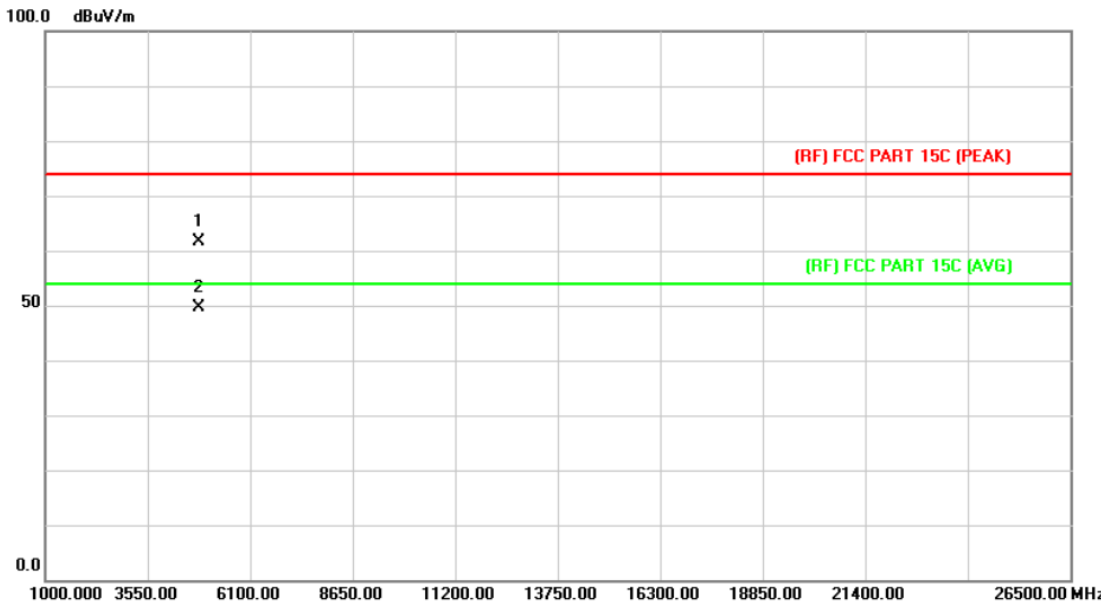

No.	Mk.	Freq.	Reading Level	Correct Factor	Measurement	Limit	Over	
		MHz	dBuV	dB/m	dBuV/m	dBuV/m	dB	Detector
1		4824.006	47.20	14.55	61.75	74.00	-12.25	peak
2	*	4824.006	34.99	14.55	49.54	54.00	-4.46	AVG

**Emission Level= Read Level+ Correct Factor**



<b>Temperature:</b>	25 °C	<b>Relative Humidity:</b>	55%
<b>Test Voltage:</b>	AC 120V/60HZ		
<b>Ant. Pol.</b>	Horizontal		
<b>Test Mode:</b>	TX G Mode 2437MHz		
<b>Remark:</b>	No report for the emission which more than 10 dB below the prescribed limit.		

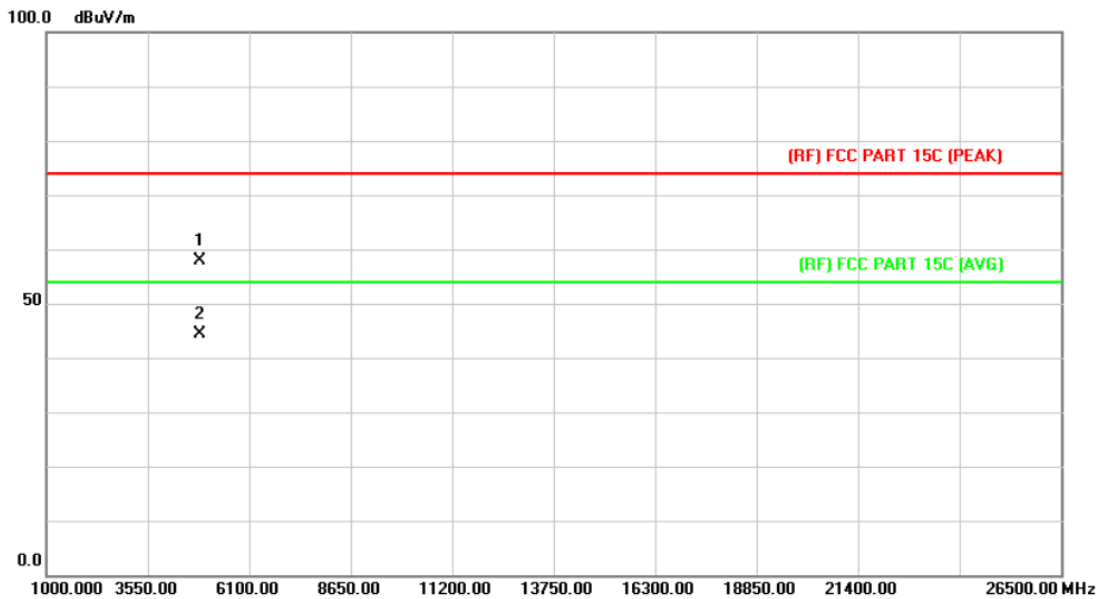

No.	Mk.	Freq. MHz	Reading Level dBuV	Correct Factor dB/m	Measure- ment dBuV/m	Limit dBuV/m	Over dB	Detector
1		4874.156	42.99	14.86	57.85	74.00	-16.15	peak
2	*	4874.528	29.42	14.86	44.28	54.00	-9.72	AVG

**Emission Level= Read Level+ Correct Factor**

<b>Temperature:</b>	25 °C	<b>Relative Humidity:</b>	55%
<b>Test Voltage:</b>	AC 120V/60HZ		
<b>Ant. Pol.</b>	Vertical		
<b>Test Mode:</b>	TX G Mode 2437MHz		
<b>Remark:</b>	No report for the emission which more than 10 dB below the prescribed limit.		

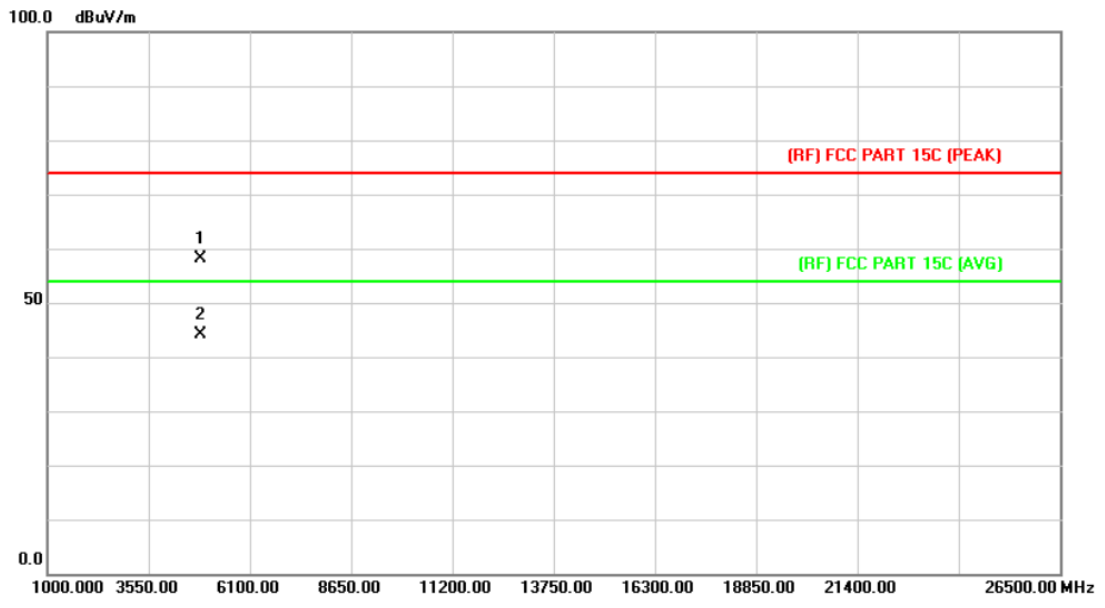

No.	Mk.	Freq. MHz	Reading Level dBuV	Correct Factor dB/m	Measure- ment dBuV/m	Limit dBuV/m	Over dB	Detector
1		4875.374	43.29	14.87	58.16	74.00	-15.84	peak
2	*	4875.398	29.38	14.87	44.25	54.00	-9.75	AVG

**Emission Level= Read Level+ Correct Factor**



<b>Temperature:</b>	25 °C	<b>Relative Humidity:</b>	55%
<b>Test Voltage:</b>	AC 120V/60HZ		
<b>Ant. Pol.</b>	Horizontal		
<b>Test Mode:</b>	TX G Mode 2462MHz		
<b>Remark:</b>	No report for the emission which more than 10 dB below the prescribed limit.		

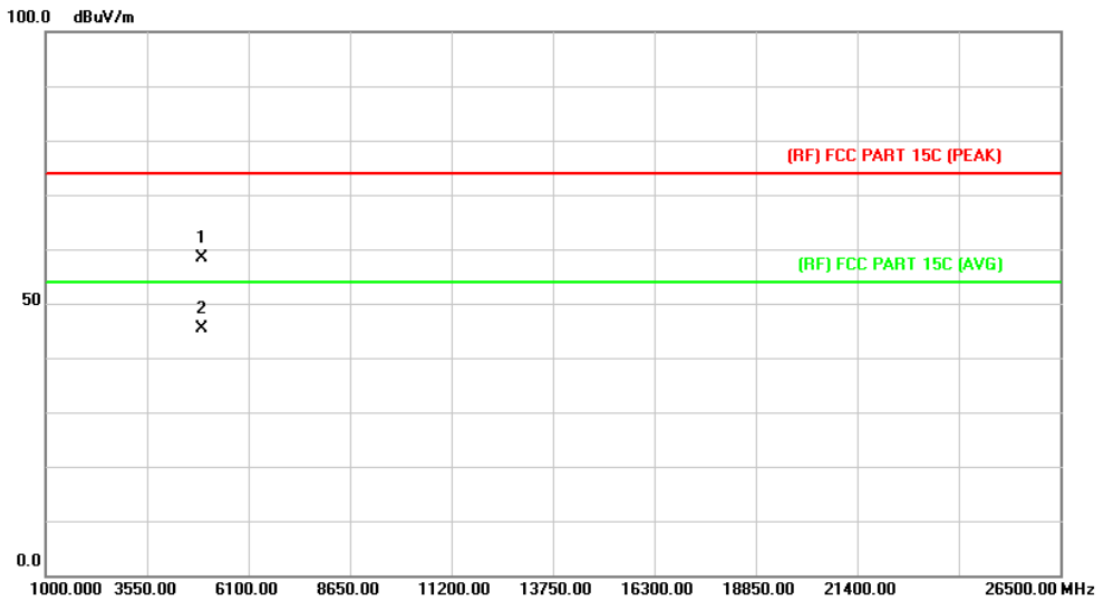

No.	Mk.	Freq.	Reading Level	Correct Factor	Measurement	Limit	Over	
		MHz	dBuV	dB/m	dBuV/m	dBuV/m	dB	Detector
1		4925.302	43.29	15.19	58.48	74.00	-15.52	peak
2	*	4925.440	30.08	15.19	45.27	54.00	-8.73	AVG

**Emission Level= Read Level+ Correct Factor**

<b>Temperature:</b>	25 °C	<b>Relative Humidity:</b>	55%
<b>Test Voltage:</b>	AC 120V/60HZ		
<b>Ant. Pol.</b>	Vertical		
<b>Test Mode:</b>	TX G Mode 2462MHz		
<b>Remark:</b>	No report for the emission which more than 10 dB below the prescribed limit.		

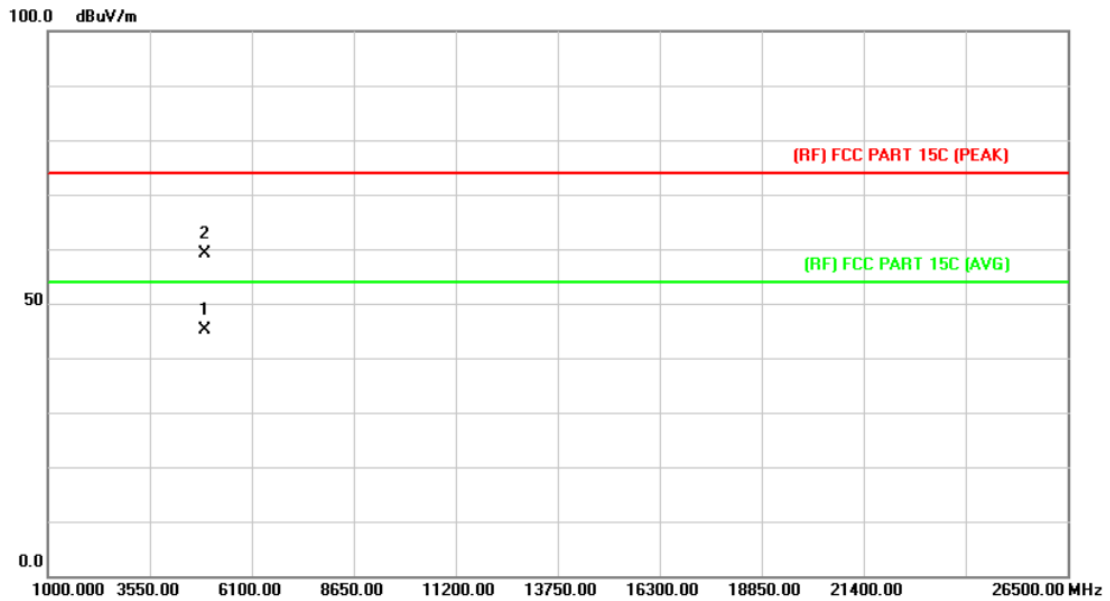

No.	Mk.	Freq.	Reading Level	Correct Factor	Measurement	Limit	Over	
		MHz	dBuV	dB/m	dBuV/m	dBuV/m	dB	Detector
1	*	4922.740	29.95	15.17	45.12	54.00	-8.88	AVG
2		4924.594	43.97	15.17	59.14	74.00	-14.86	peak

**Emission Level= Read Level+ Correct Factor**



<b>Temperature:</b>	25 °C	<b>Relative Humidity:</b>	55%
<b>Test Voltage:</b>	AC 120V/60HZ		
<b>Ant. Pol.</b>	Horizontal		
<b>Test Mode:</b>	TX N(HT20) Mode 2412MHz		
<b>Remark:</b>	No report for the emission which more than 10 dB below the prescribed limit.		

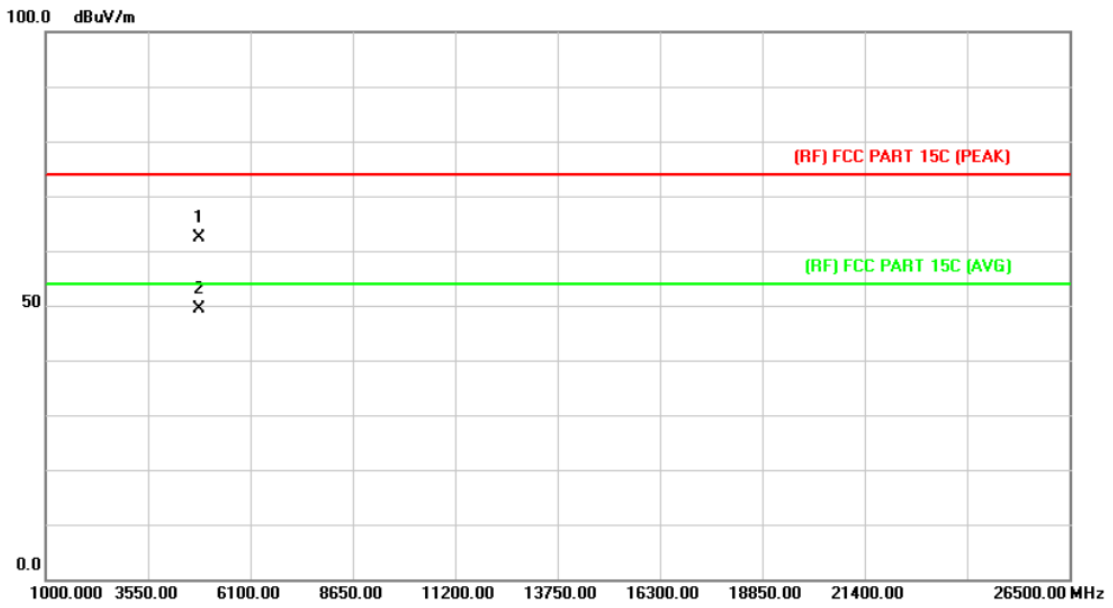

No.	Mk.	Freq. MHz	Reading Level dBuV	Correct Factor dB/m	Measure- ment dBuV/m	Limit dBuV/m	Over dB	Detector
1		4823.664	47.90	14.55	62.45	74.00	-11.55	peak
2	*	4823.664	34.90	14.55	49.45	54.00	-4.55	AVG

**Emission Level= Read Level+ Correct Factor**

<b>Temperature:</b>	25 °C	<b>Relative Humidity:</b>	55%
<b>Test Voltage:</b>	AC 120V/60HZ		
<b>Ant. Pol.</b>	Vertical		
<b>Test Mode:</b>	TX N(HT20) Mode 2412MHz		
<b>Remark:</b>	No report for the emission which more than 10 dB below the prescribed limit.		

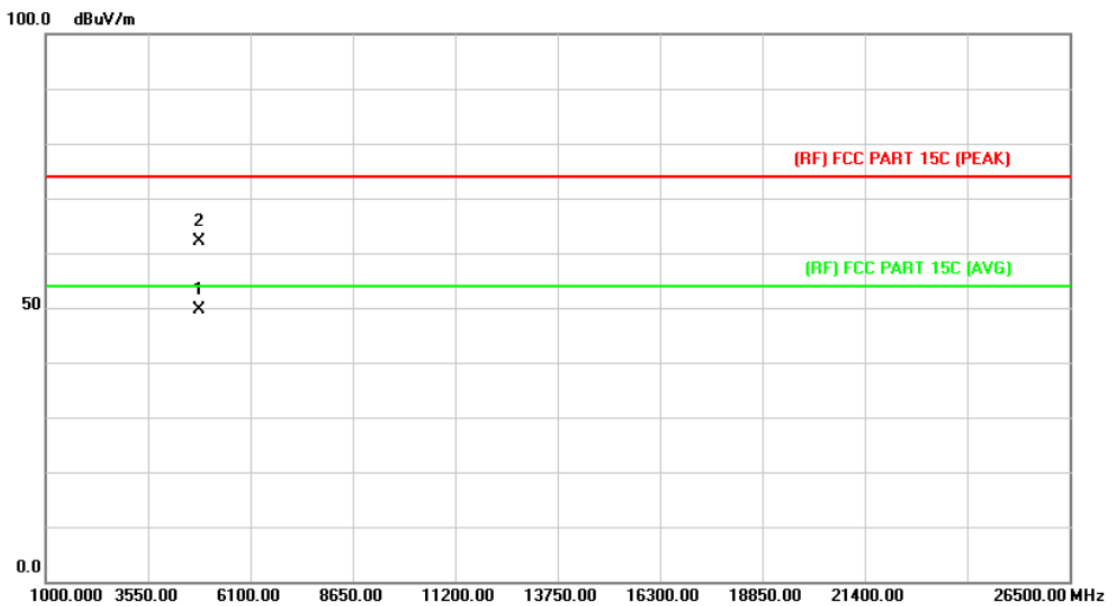

No.	Mk.	Freq. MHz	Reading Level dBuV	Correct Factor dB/m	Measure- ment dBuV/m	Limit dBuV/m	Over dB	Detector
1	*	4824.048	35.07	14.55	49.62	54.00	-4.38	AVG
2		4824.120	47.59	14.55	62.14	74.00	-11.86	peak

**Emission Level= Read Level+ Correct Factor**



<b>Temperature:</b>	25 °C	<b>Relative Humidity:</b>	55%
<b>Test Voltage:</b>	AC 120V/60HZ		
<b>Ant. Pol.</b>	Horizontal		
<b>Test Mode:</b>	TX N(HT20) Mode 2437MHz		
<b>Remark:</b>	No report for the emission which more than 10 dB below the prescribed limit.		

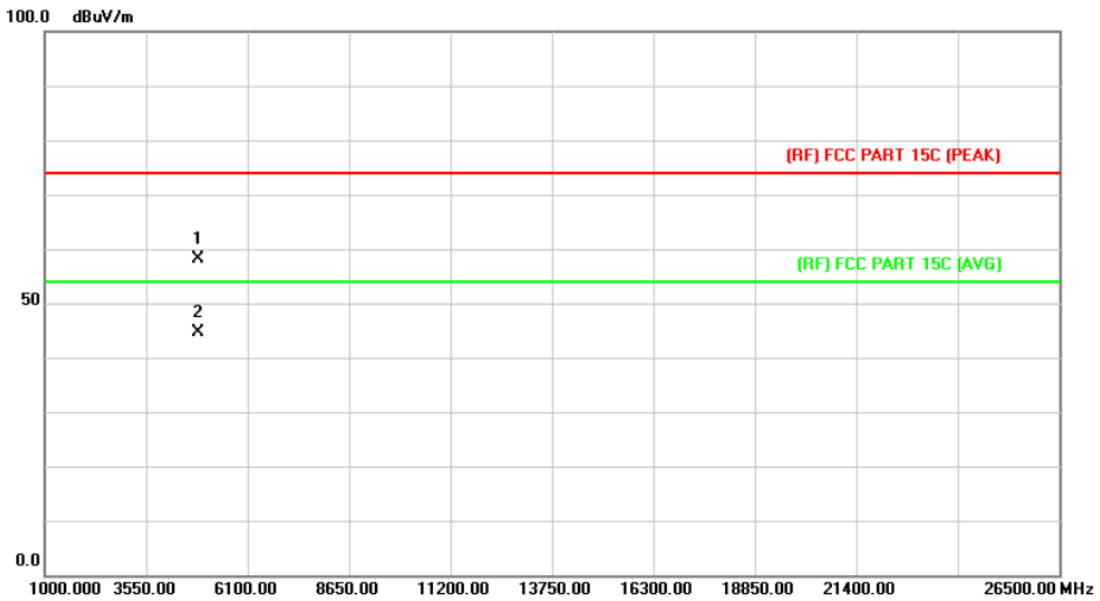

No.	Mk.	Freq.	Reading Level	Correct Factor	Measurement	Limit	Over	Detector
		MHz	dBuV	dB/m	dBuV/m	dBuV/m	dB	
1		4873.160	43.28	14.85	58.13	74.00	-15.87	peak
2	*	4875.482	29.65	14.87	44.52	54.00	-9.48	AVG

**Emission Level= Read Level+ Correct Factor**

<b>Temperature:</b>	25 °C	<b>Relative Humidity:</b>	55%
<b>Test Voltage:</b>	AC 120V/60HZ		
<b>Ant. Pol.</b>	Vertical		
<b>Test Mode:</b>	TX N(HT20) Mode 2437MHz		
<b>Remark:</b>	No report for the emission which more than 10 dB below the prescribed limit.		

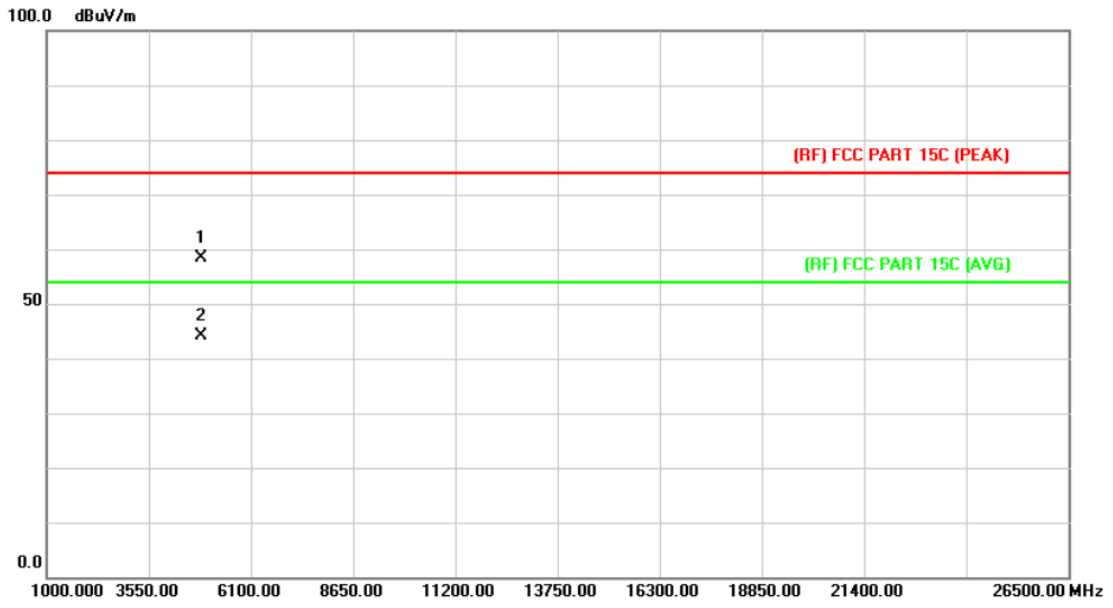

No.	Mk.	Freq. MHz	Reading Level dBuV	Correct Factor dB/m	Measure- ment dBuV/m	Limit dBuV/m	Over dB	Detector
1		4873.922	43.58	14.86	58.44	74.00	-15.56	peak
2	*	4873.922	29.39	14.86	44.25	54.00	-9.75	AVG

**Emission Level= Read Level+ Correct Factor**



<b>Temperature:</b>	25 °C	<b>Relative Humidity:</b>	55%
<b>Test Voltage:</b>	AC 120V/60HZ		
<b>Ant. Pol.</b>	Horizontal		
<b>Test Mode:</b>	TX N(HT20) Mode 2462MHz		
<b>Remark:</b>	No report for the emission which more than 10 dB below the prescribed limit.		

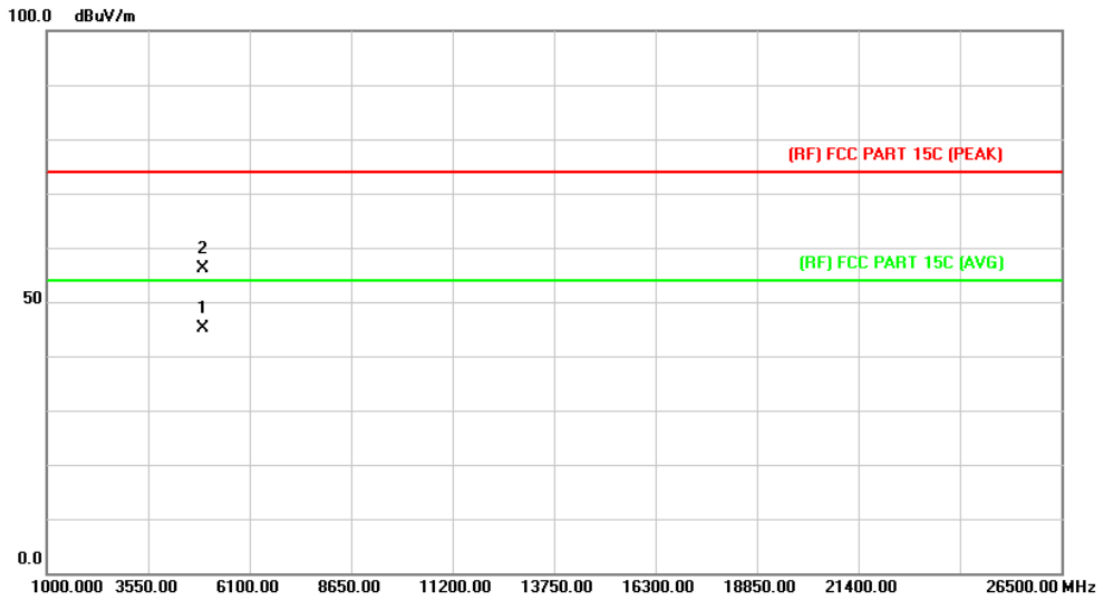

No.	Mk.	Freq.	Reading Level	Correct Factor	Measurement	Limit	Over	Detector
		MHz	dBuV	dB/m	dBuV/m	dBuV/m	dB	
1	*	4925.302	30.06	15.19	45.25	54.00	-8.75	AVG
2		4925.332	40.92	15.19	56.11	74.00	-17.89	peak

**Emission Level= Read Level+ Correct Factor**

<b>Temperature:</b>	25 °C	<b>Relative Humidity:</b>	55%
<b>Test Voltage:</b>	AC 120V/60HZ		
<b>Ant. Pol.</b>	Vertical		
<b>Test Mode:</b>	TX N(HT20) Mode 2462MHz		
<b>Remark:</b>	No report for the emission which more than 10 dB below the prescribed limit.		

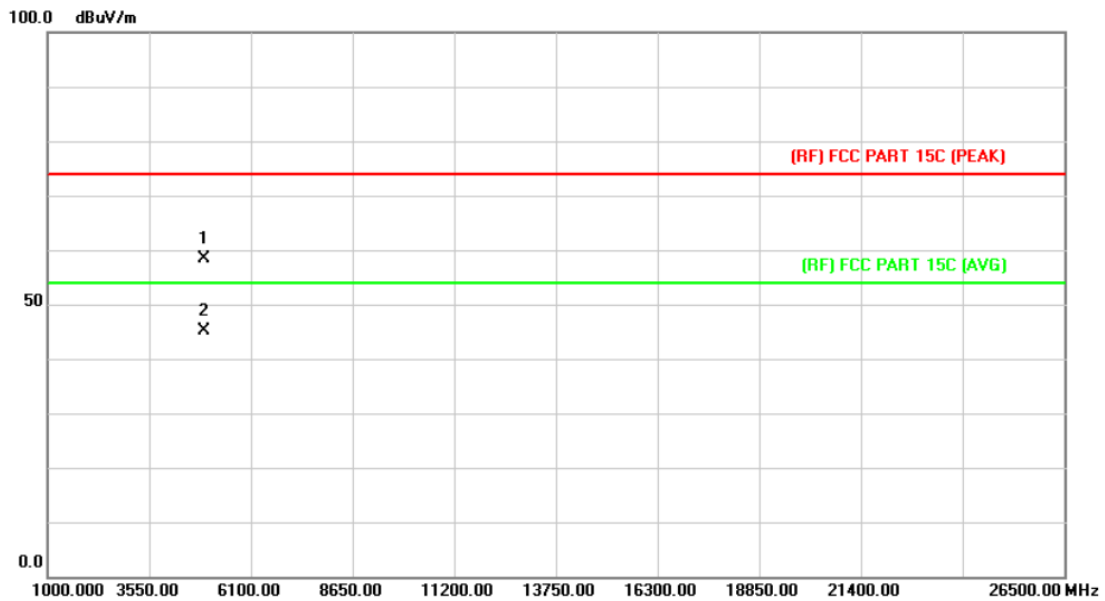

No.	Mk.	Freq. MHz	Reading Level dBuV	Correct Factor dB/m	Measure- ment dBuV/m	Limit dBuV/m	Over dB	Detector
1		4923.058	43.29	15.17	58.46	74.00	-15.54	peak
2	*	4925.302	29.95	15.19	45.14	54.00	-8.86	AVG

**Emission Level= Read Level+ Correct Factor**



### Attachment C-- Restricted Bands Requirement Test Data

#### (1) Radiation Test

Temperature:	25 °C	Relative Humidity:	55%
Test Voltage:	AC 120V/60HZ		
Ant. Pol.	Horizontal		
Test Mode:	TX B Mode 2412MHz		
Remark:	N/A		

No.	Mk.	Freq. MHz	Reading Level dBuV	Correct Factor dB/m	Measure- ment dBuV/m	Limit dBuV/m	Over dB	Detector
1		2390.000	55.33	2.82	58.15	74.00	-15.85	peak
2		2390.000	44.44	2.82	47.26	54.00	-6.74	AVG
3	*	2410.400	88.65	2.93	91.58	Fundamental Frequency		AVG
4	X	2410.600	98.09	2.93	101.02	Fundamental Frequency		peak

Emission Level= Read Level+ Correct Factor

<b>Temperature:</b>	25 °C	<b>Relative Humidity:</b>	55%
<b>Test Voltage:</b>	AC 120V/60HZ		
<b>Ant. Pol.</b>	Vertical		
<b>Test Mode:</b>	TX B Mode 2412MHz		
<b>Remark:</b>	N/A		

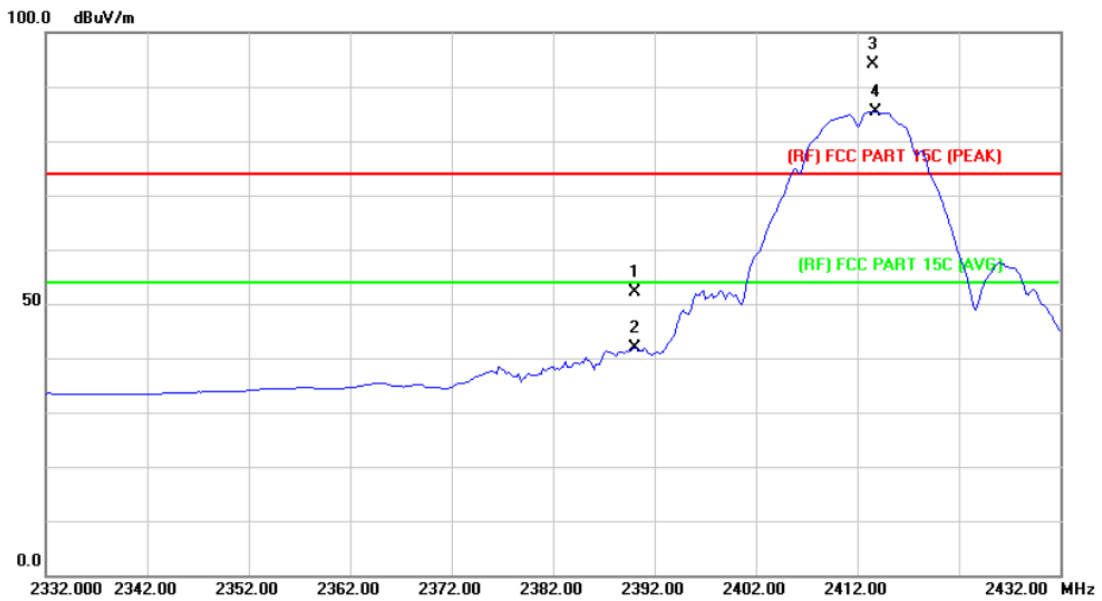

No.	Mk.	Freq. MHz	Reading	Correct	Measurement	Limit	Over	Detector
			Level dBuV	Factor dB/m	dBuV/m			
1		2390.000	49.30	2.82	52.12	74.00	-21.88	peak
2		2390.000	39.16	2.82	41.98	54.00	-12.02	AVG
3	X	2413.600	91.20	2.95	94.15	Fundamental Frequency		peak
4	*	2413.800	82.43	2.95	85.38	Fundamental Frequency		AVG

**Emission Level= Read Level+ Correct Factor**



<b>Temperature:</b>	25 °C	<b>Relative Humidity:</b>	55%
<b>Test Voltage:</b>	AC 120V/60HZ		
<b>Ant. Pol.</b>	Horizontal		
<b>Test Mode:</b>	TX B Mode 2462MHz		
<b>Remark:</b>	N/A		

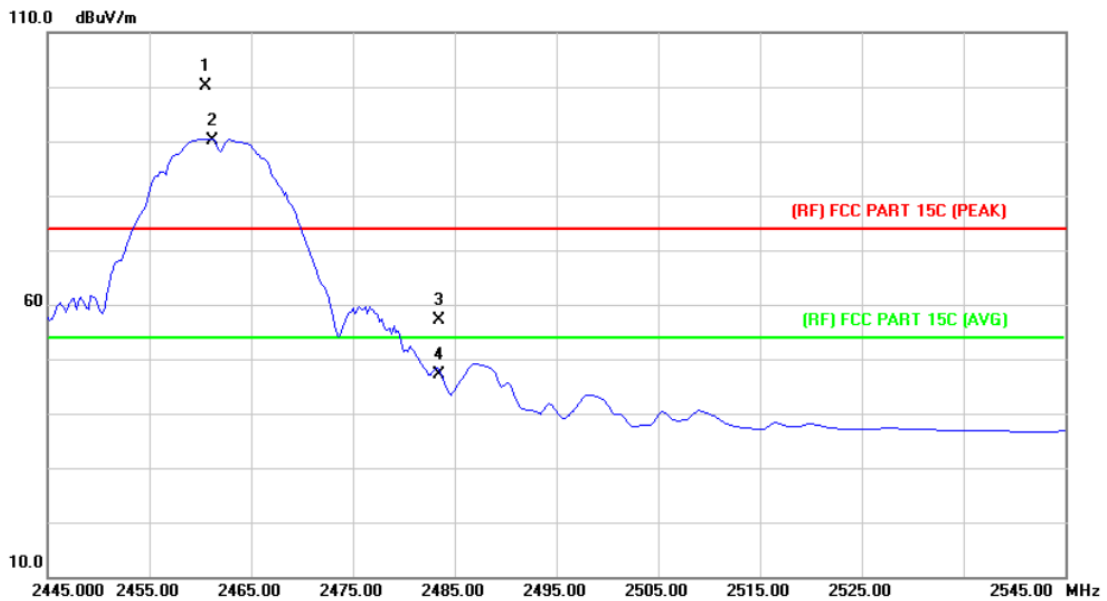

No.	Mk.	Freq.	Reading Level	Correct Factor	Measurement	Limit	Over	
		MHz	dBuV	dB/m	dBuV/m	dBuV/m	dB	Detector
1	X	2460.600	96.76	3.26	100.02	Fundamental Frequency		peak
2	*	2461.200	86.86	3.27	90.13	Fundamental Frequency		AVG
3		2483.500	53.63	3.41	57.04	74.00	-16.96	peak
4		2483.500	43.84	3.41	47.25	54.00	-6.75	AVG

**Emission Level= Read Level+ Correct Factor**

<b>Temperature:</b>	25 °C	<b>Relative Humidity:</b>	55%
<b>Test Voltage:</b>	AC 120V/60HZ		
<b>Ant. Pol.</b>	Vertical		
<b>Test Mode:</b>	TX B Mode 2462MHz		
<b>Remark:</b>	N/A		

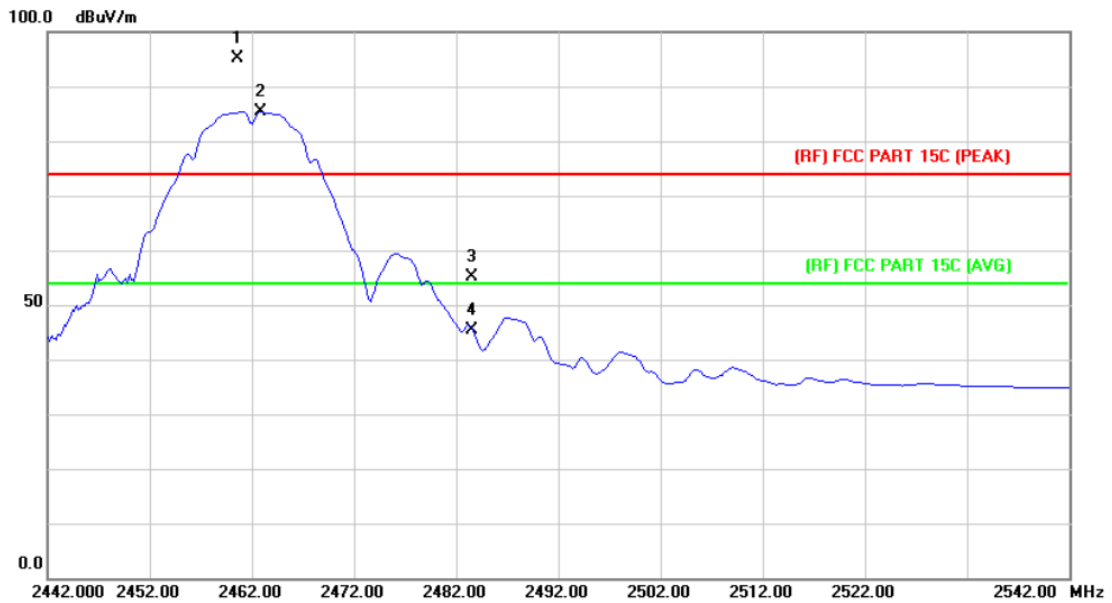

No.	Mk.	Freq.	Reading Level	Correct Factor	Measurement	Limit	Over	Detector
		MHz	dBuV	dB/m	dBuV/m	dBuV/m	dB	
1	X	2460.600	91.88	3.26	95.14	Fundamental Frequency		peak
2	*	2462.800	82.07	3.27	85.34	Fundamental Frequency		AVG
3		2483.500	51.73	3.41	55.14	74.00	-18.86	peak
4		2483.500	42.09	3.41	45.50	54.00	-8.50	AVG

**Emission Level= Read Level+ Correct Factor**



<b>Temperature:</b>	25 °C	<b>Relative Humidity:</b>	55%
<b>Test Voltage:</b>	AC 120V/60HZ		
<b>Ant. Pol.</b>	Horizontal		
<b>Test Mode:</b>	TX G Mode 2412MHz		
<b>Remark:</b>	N/A		

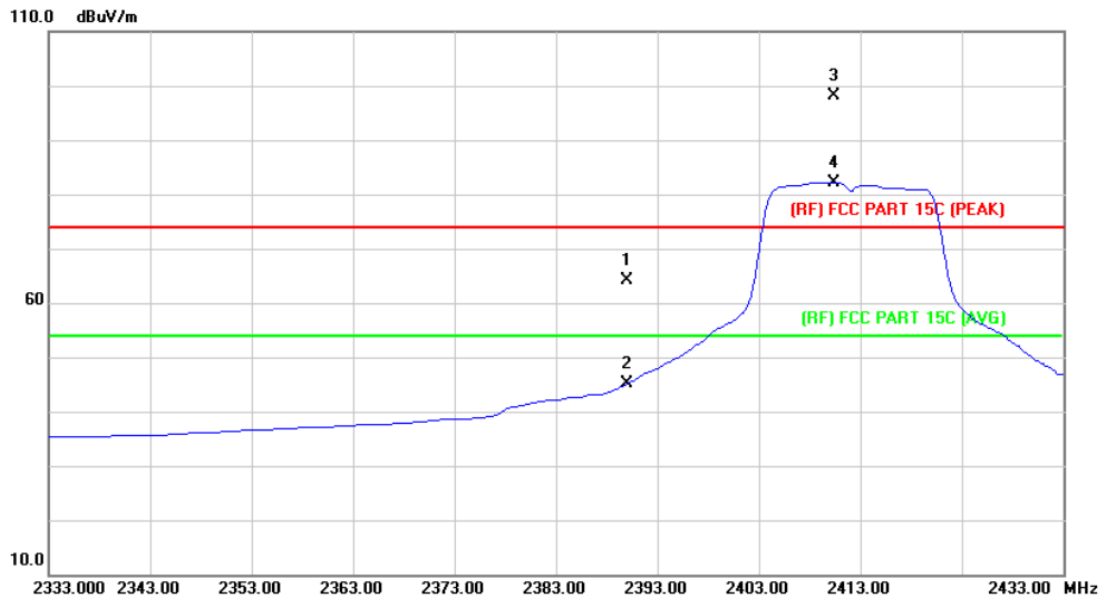

No.	Mk.	Freq.	Reading Level	Correct Factor	Measurement	Limit	Over	Detector
		MHz	dBuV	dB/m	dBuV/m	dBuV/m	dB	
1		2390.000	61.33	2.82	64.15	74.00	-9.85	peak
2		2390.000	42.23	2.82	45.05	54.00	-8.95	AVG
3	X	2410.400	95.22	2.93	98.15	Fundamental Frequency		peak
4	*	2410.400	79.21	2.93	82.14	Fundamental Frequency		AVG

**Emission Level= Read Level+ Correct Factor**

<b>Temperature:</b>	25 °C	<b>Relative Humidity:</b>	55%
<b>Test Voltage:</b>	AC 120V/60HZ		
<b>Ant. Pol.</b>	Vertical		
<b>Test Mode:</b>	TX G Mode 2412MHz		
<b>Remark:</b>	N/A		

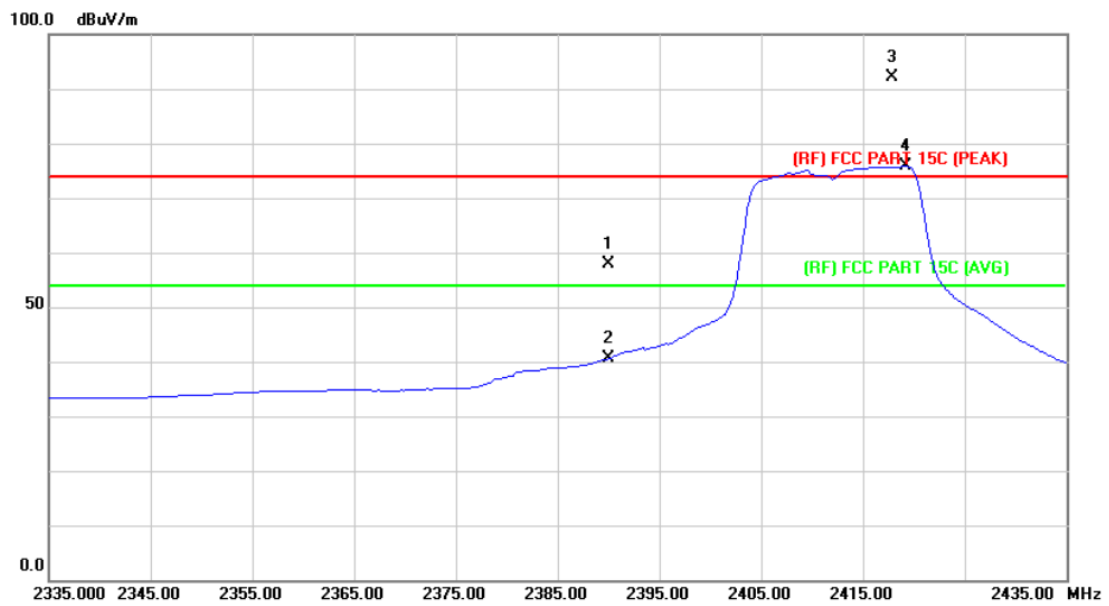

No.	Mk.	Freq.	Reading Level	Correct Factor	Measurement	Limit	Over	
		MHz	dBuV	dB/m	dBuV/m	dBuV/m	dB	Detector
1		2390.000	55.02	2.82	57.84	74.00	-16.16	peak
2		2390.000	37.77	2.82	40.59	54.00	-13.41	AVG
3	X	2417.800	89.03	2.98	92.01	Fundamental Frequency		peak
4	*	2419.200	72.79	2.99	75.78	Fundamental Frequency		AVG

**Emission Level= Read Level+ Correct Factor**



<b>Temperature:</b>	25 °C	<b>Relative Humidity:</b>	55%
<b>Test Voltage:</b>	AC 120V/60HZ		
<b>Ant. Pol.</b>	Horizontal		
<b>Test Mode:</b>	TX G Mode 2462MHz		
<b>Remark:</b>	N/A		

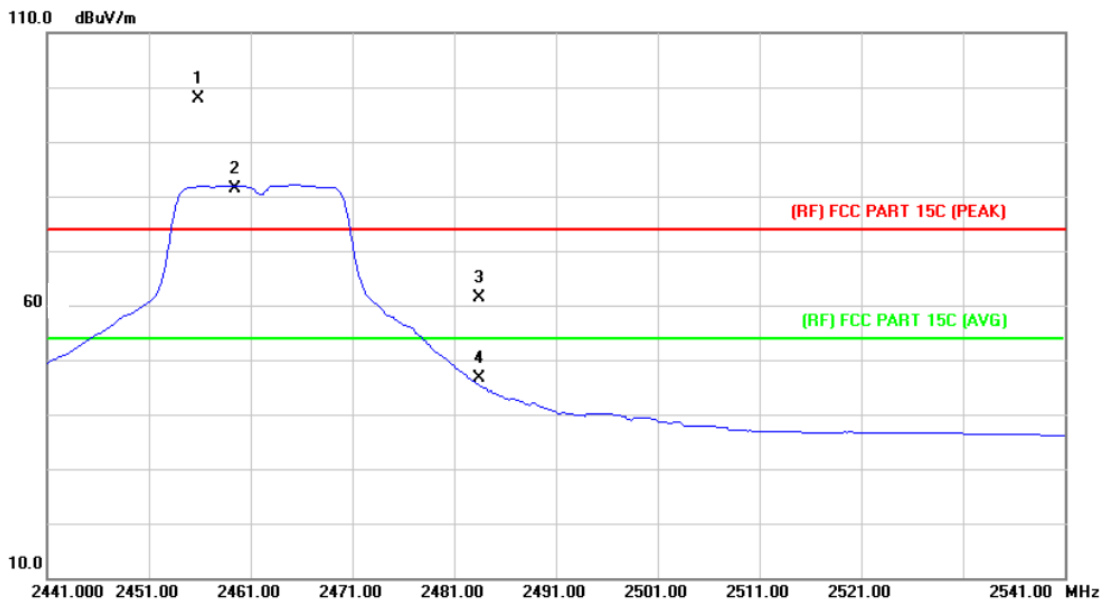

No.	Mk.	Freq. MHz	Reading Level dBuV	Correct Factor dB/m	Measure- ment dBuV/m	Limit dBuV/m	Over dB	Detector
1	X	2455.800	94.66	3.23	97.89	Fundamental Frequency		peak
2	*	2459.400	78.24	3.25	81.49	Fundamental Frequency		AVG
3		2483.500	58.04	3.41	61.45	74.00	-12.55	peak
4		2483.500	43.11	3.41	46.52	54.00	-7.48	AVG

**Emission Level= Read Level+ Correct Factor**

Temperature:	25 °C	Relative Humidity:	55%
Test Voltage:	AC 120V/60HZ		
Ant. Pol.	Vertical		
Test Mode:	TX G Mode 2462MHz		
Remark:	N/A		

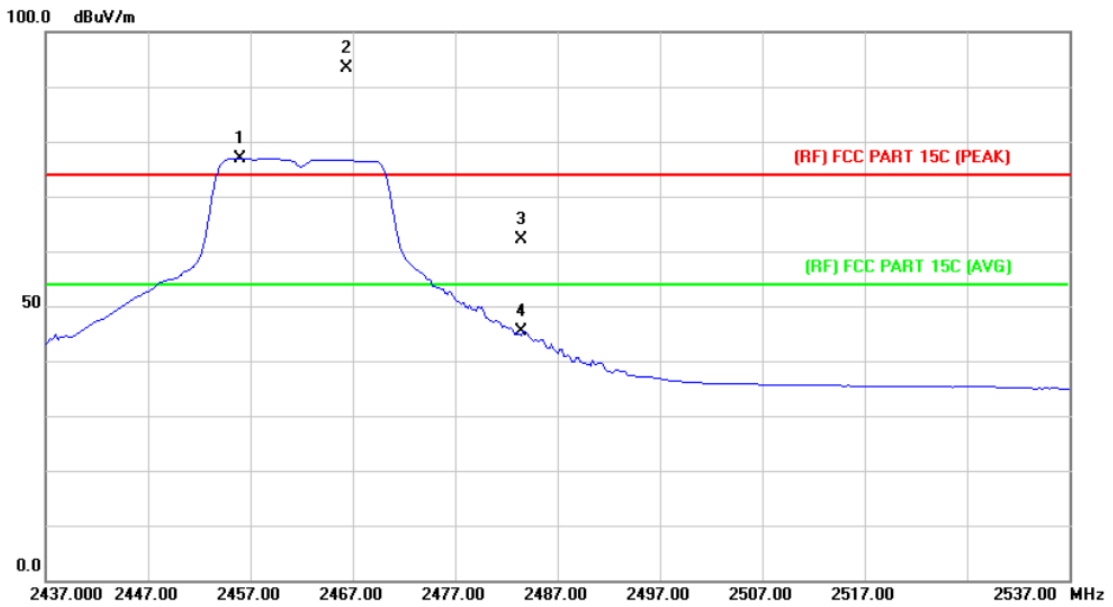

No.	Mk.	Freq. MHz	Reading Level dBuV	Correct Factor dB/m	Measure- ment dBuV/m	Limit dBuV/m	Over dB	Detector
1	*	2456.000	73.62	3.23	76.85	Fundamental Frequency		AVG
2	X	2466.400	90.05	3.29	93.34	Fundamental Frequency		peak
3		2483.500	58.72	3.41	62.13	74.00	-11.87	peak
4		2483.500	42.09	3.41	45.50	54.00	-8.50	AVG

Emission Level= Read Level+ Correct Factor



<b>Temperature:</b>	25 °C	<b>Relative Humidity:</b>	55%
<b>Test Voltage:</b>	AC 120V/60HZ		
<b>Ant. Pol.</b>	Horizontal		
<b>Test Mode:</b>	TX N(HT20) Mode 2412MHz		
<b>Remark:</b>	N/A		

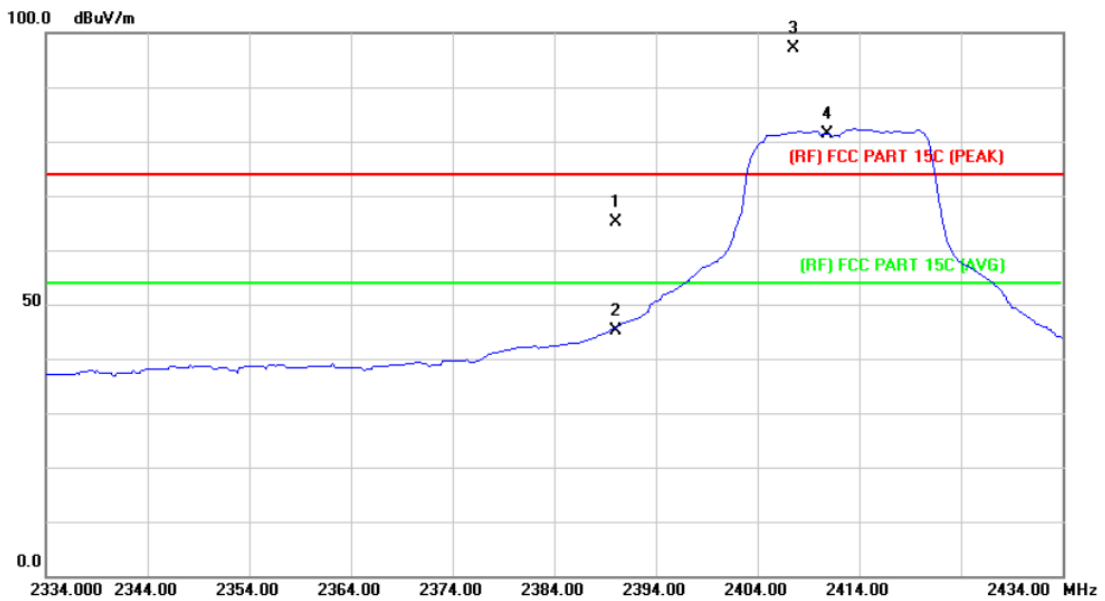

No.	Mk.	Freq. MHz	Reading Level dBuV	Correct Factor dB/m	Measure- ment dBuV/m	Limit dBuV/m	Over dB	Detector
1		2390.000	62.30	2.82	65.12	74.00	-8.88	peak
2		2390.000	42.43	2.82	45.25	54.00	-8.75	AVG
3	X	2407.600	94.33	2.91	97.24	Fundamental Frequency	↓	peak
4	*	2410.800	78.52	2.93	81.45	Fundamental Frequency	↓	AVG

**Emission Level= Read Level+ Correct Factor**

<b>Temperature:</b>	25 °C	<b>Relative Humidity:</b>	55%
<b>Test Voltage:</b>	AC 120V/60HZ		
<b>Ant. Pol.</b>	Vertical		
<b>Test Mode:</b>	TX N(HT20) Mode 2412MHz		
<b>Remark:</b>	N/A		

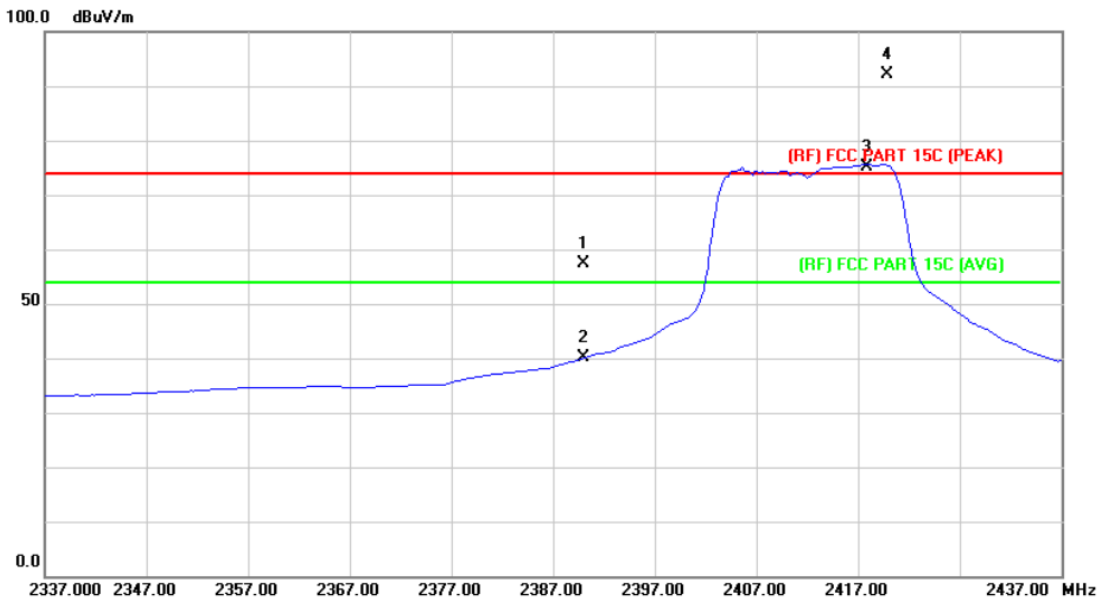

No.	Mk.	Freq.	Reading Level	Correct Factor	Measurement	Limit	Over	
		MHz	dBuV	dB/m	dBuV/m	dBuV/m	dB	Detector
1		2390.000	54.66	2.82	57.48	74.00	-16.52	peak
2		2390.000	37.23	2.82	40.05	54.00	-13.95	AVG
3	*	2417.800	72.07	2.98	75.05	Fundamental Frequency		AVG
4	X	2419.800	89.08	2.99	92.07	Fundamental Frequency		peak

**Emission Level= Read Level+ Correct Factor**



<b>Temperature:</b>	25 °C	<b>Relative Humidity:</b>	55%
<b>Test Voltage:</b>	AC 120V/60HZ		
<b>Ant. Pol.</b>	Horizontal		
<b>Test Mode:</b>	TX N(HT20) Mode 2462MHz		
<b>Remark:</b>	N/A		

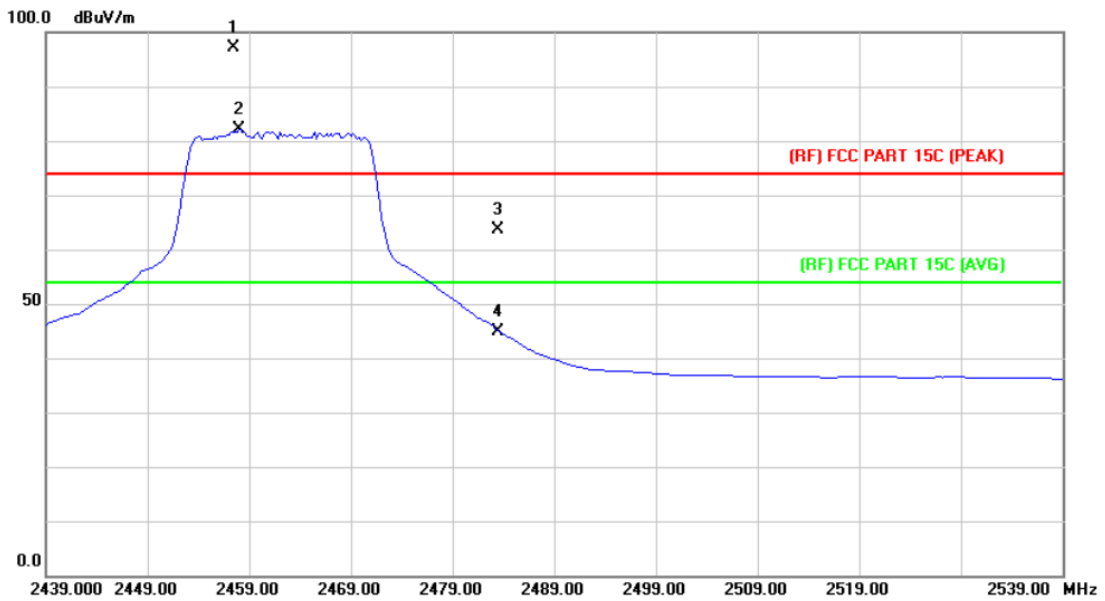

No.	Mk.	Freq. MHz	Reading	Correct	Measure-	Limit	Over	Detector
			Level	Factor	ment			
			dBuV	dB/m	dBuV/m	dBuV/m	dB	
1	X	2457.400	93.77	3.24	97.01	Fundamental Frequency		peak
2	*	2458.000	78.91	3.24	82.15	Fundamental Frequency		AVG
3		2483.500	60.23	3.41	63.64	74.00	-10.36	peak
4		2483.500	41.46	3.41	44.87	54.00	-9.13	AVG

**Emission Level= Read Level+ Correct Factor**

<b>Temperature:</b>	25 °C	<b>Relative Humidity:</b>	55%
<b>Test Voltage:</b>	AC 120V/60HZ		
<b>Ant. Pol.</b>	Vertical		
<b>Test Mode:</b>	TX N(HT20) Mode 2462MHz		
<b>Remark:</b>	N/A		

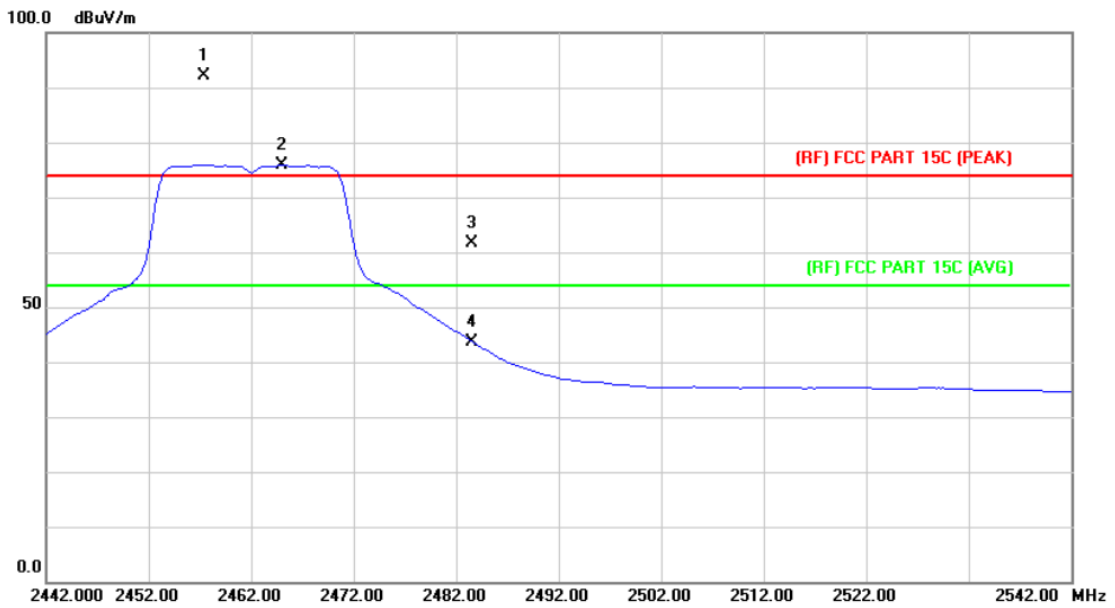

No.	Mk.	Freq.	Reading Level	Correct Factor	Measurement	Limit	Over	Detector
		MHz	dBuV	dB/m	dBuV/m	dBuV/m	dB	
1	X	2457.400	88.97	3.24	92.21	Fundamental Frequency		peak
2	*	2465.000	72.60	3.28	75.88	Fundamental Frequency		AVG
3		2483.500	58.33	3.41	61.74	74.00	-12.26	peak
4		2483.500	40.18	3.41	43.59	54.00	-10.41	AVG

**Emission Level= Read Level+ Correct Factor**



## (2) Conducted Test

<b>Temperature:</b>	25 °C	<b>Relative Humidity:</b>	55%
<b>Test Voltage:</b>	AC 120V/60HZ		
<b>Test Mode:</b>	TX B Mode 2412MHz / TX B Mode 2462MHz		
<b>Remark:</b>	The EUT is programed in continuously transmitting mode		

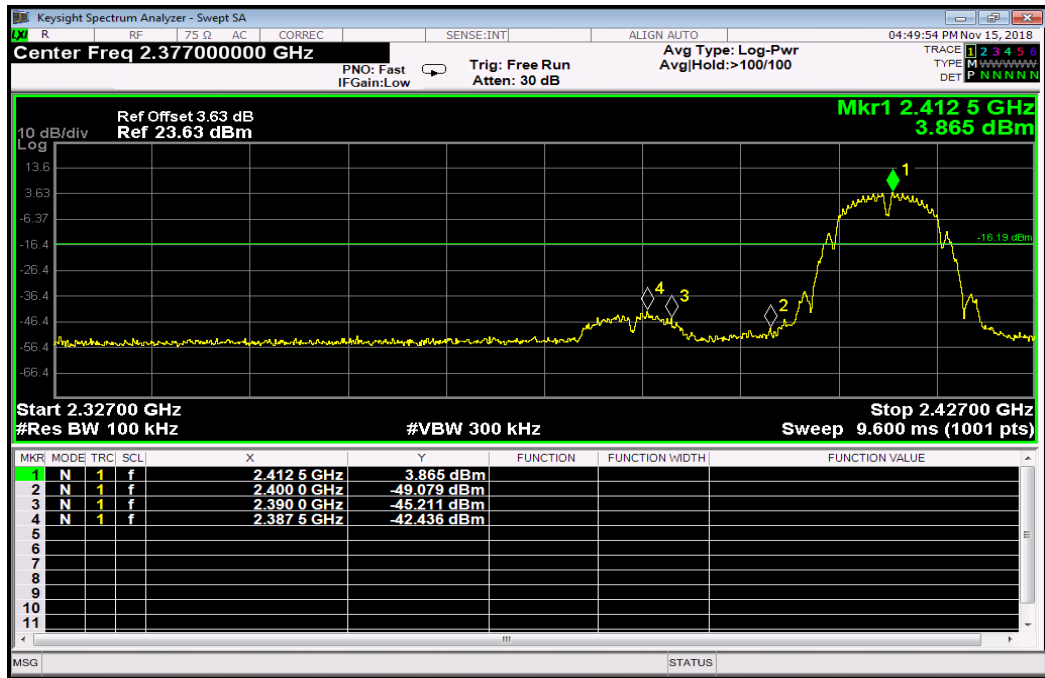

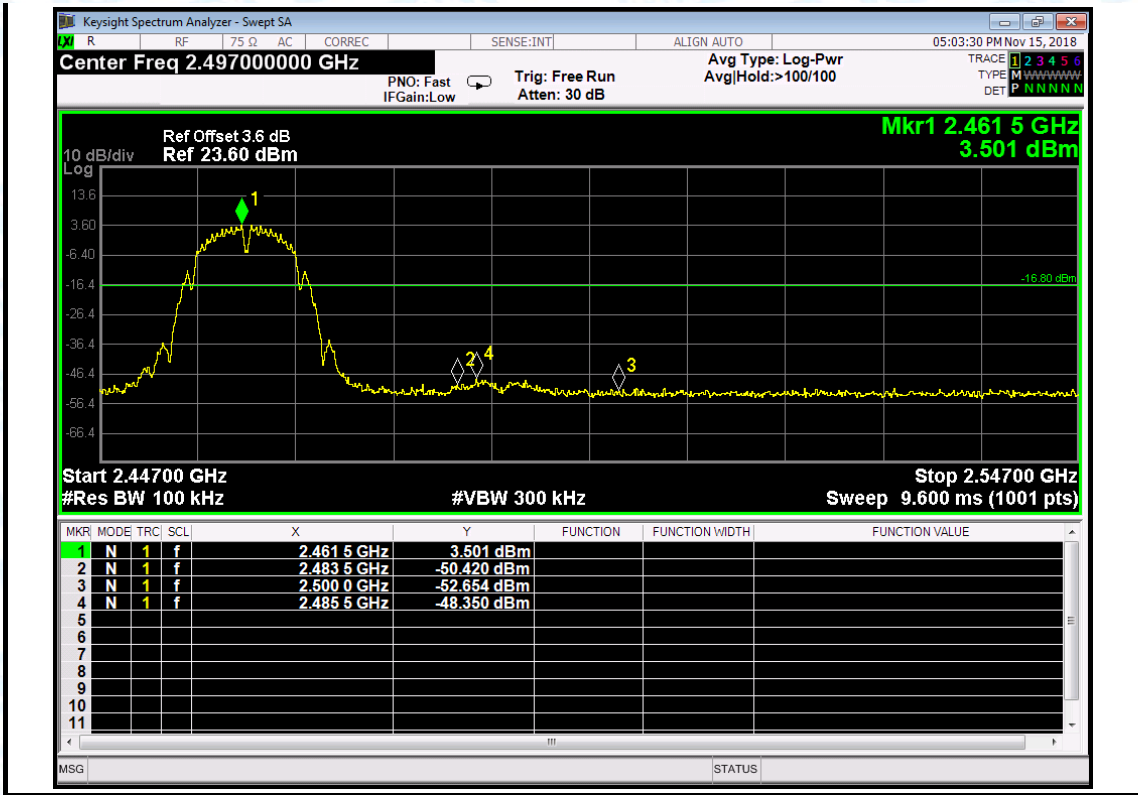



Temperature:	25 °C	Relative Humidity:	55%
Test Voltage:	AC 120V/60HZ		
Test Mode:	TX G Mode 2412MHz / TX G Mode 2462MHz		
Remark:	The EUT is programed in continuously transmitting mode		

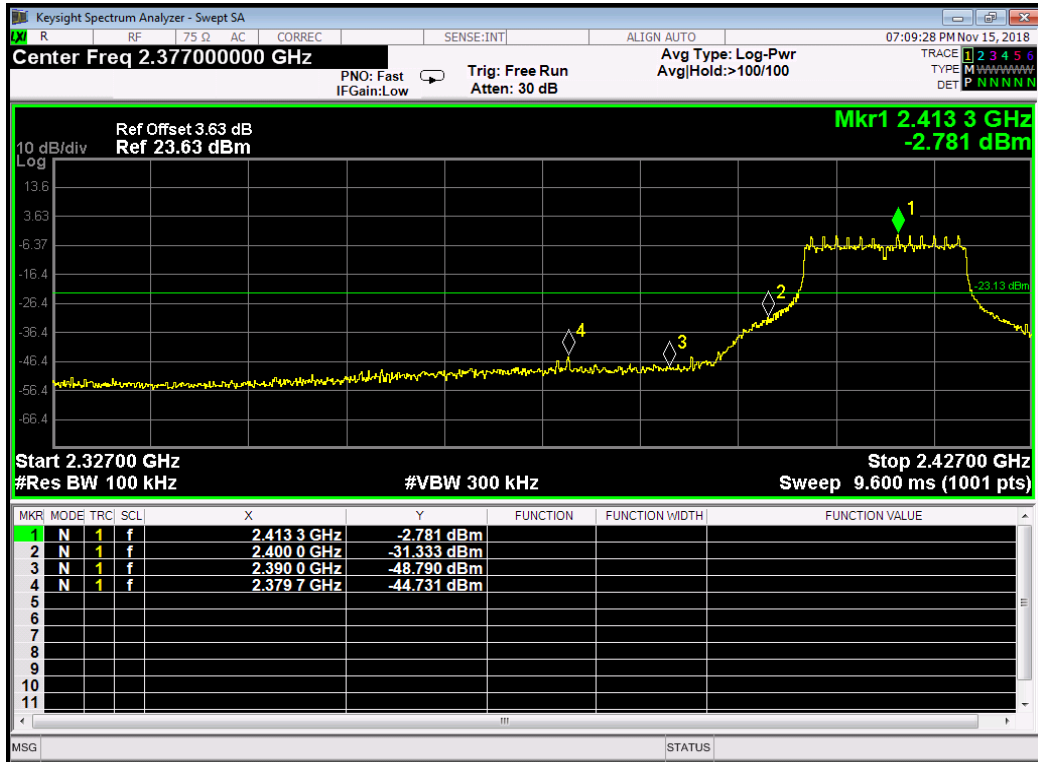

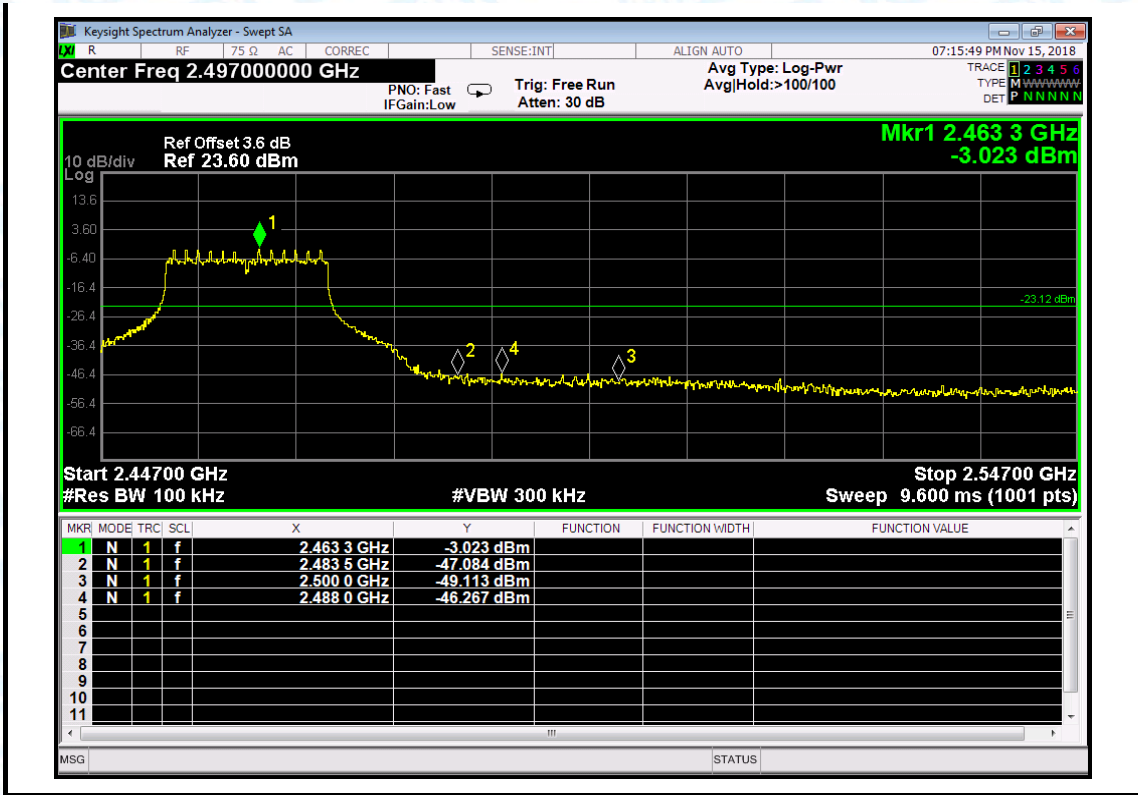



<b>Temperature:</b>	25 °C	<b>Relative Humidity:</b>	55%
<b>Test Voltage:</b>	AC 120V/60HZ		
<b>Test Mode:</b>	TX N(HT20) Mode 2412MHz / TX N(HT20) Mode 2462MHz		
<b>Remark:</b>	The EUT is programed in continuously transmitting mode		

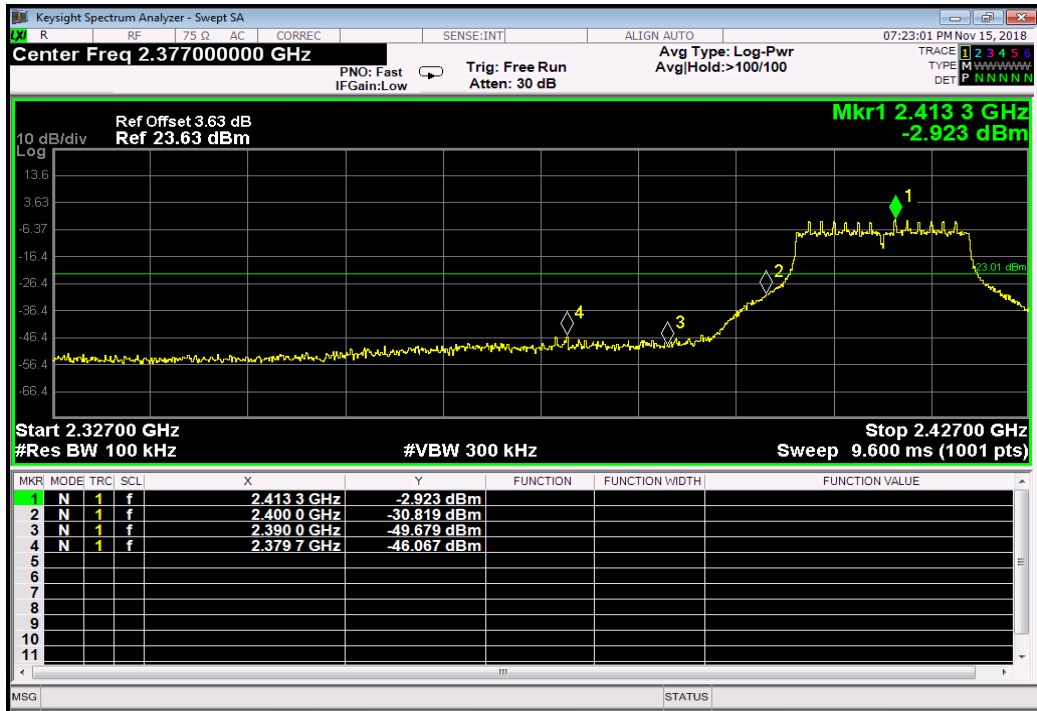

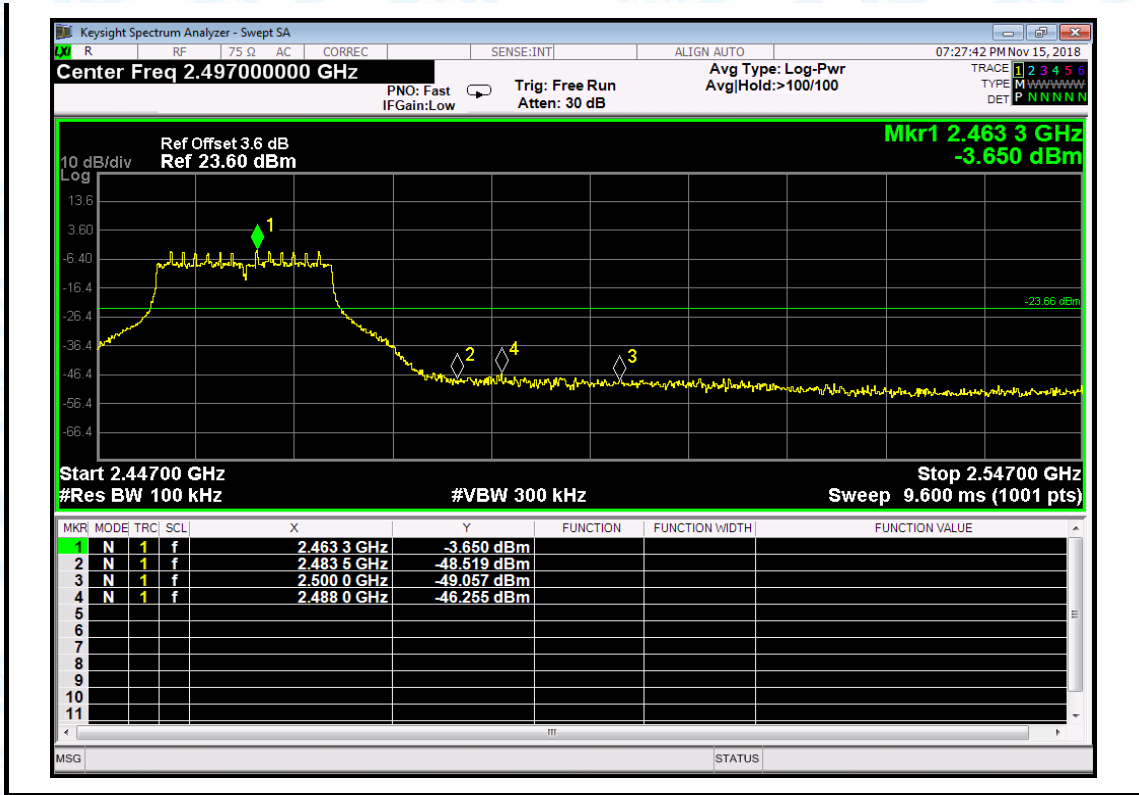



## Attachment D-- Bandwidth Test Data

Temperature:	25 °C	Relative Humidity:	55%
Test Voltage:	AC 120V/60HZ		
Test Mode:	TX 802.11B Mode		
Channel frequency (MHz)	6dB Bandwidth (MHz)	99% Bandwidth (MHz)	Limit (MHz)
2412	8.220	10.527	>=0.5
2437	8.223	10.575	
2462	8.225	10.573	

### 802.11B Mode

### 2412 MHz

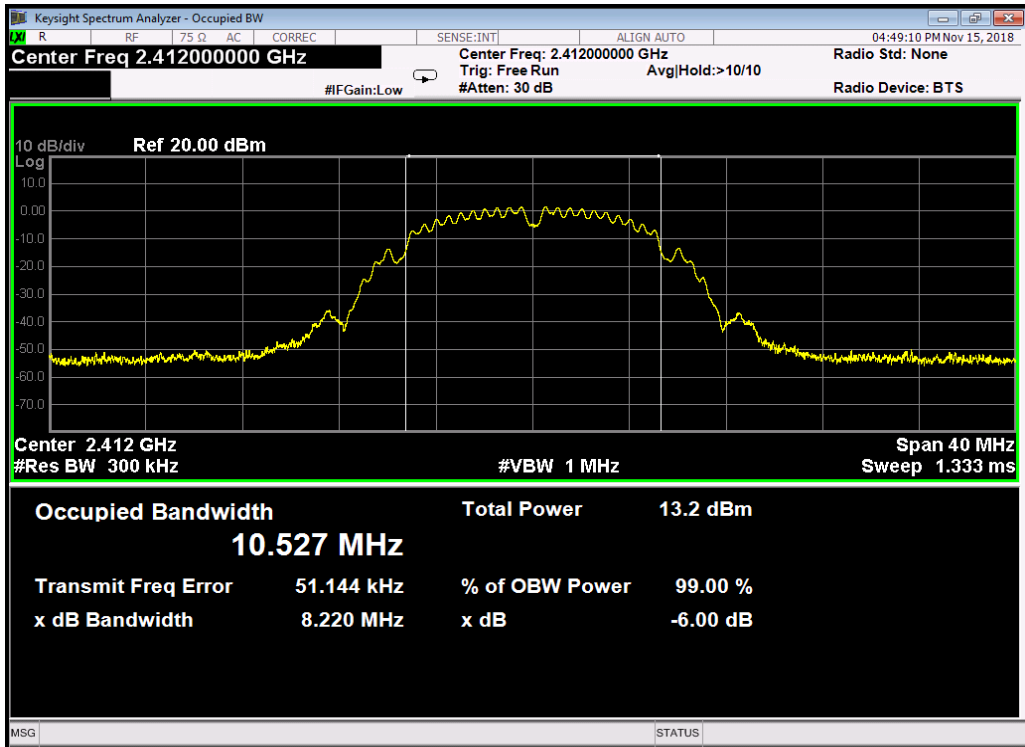

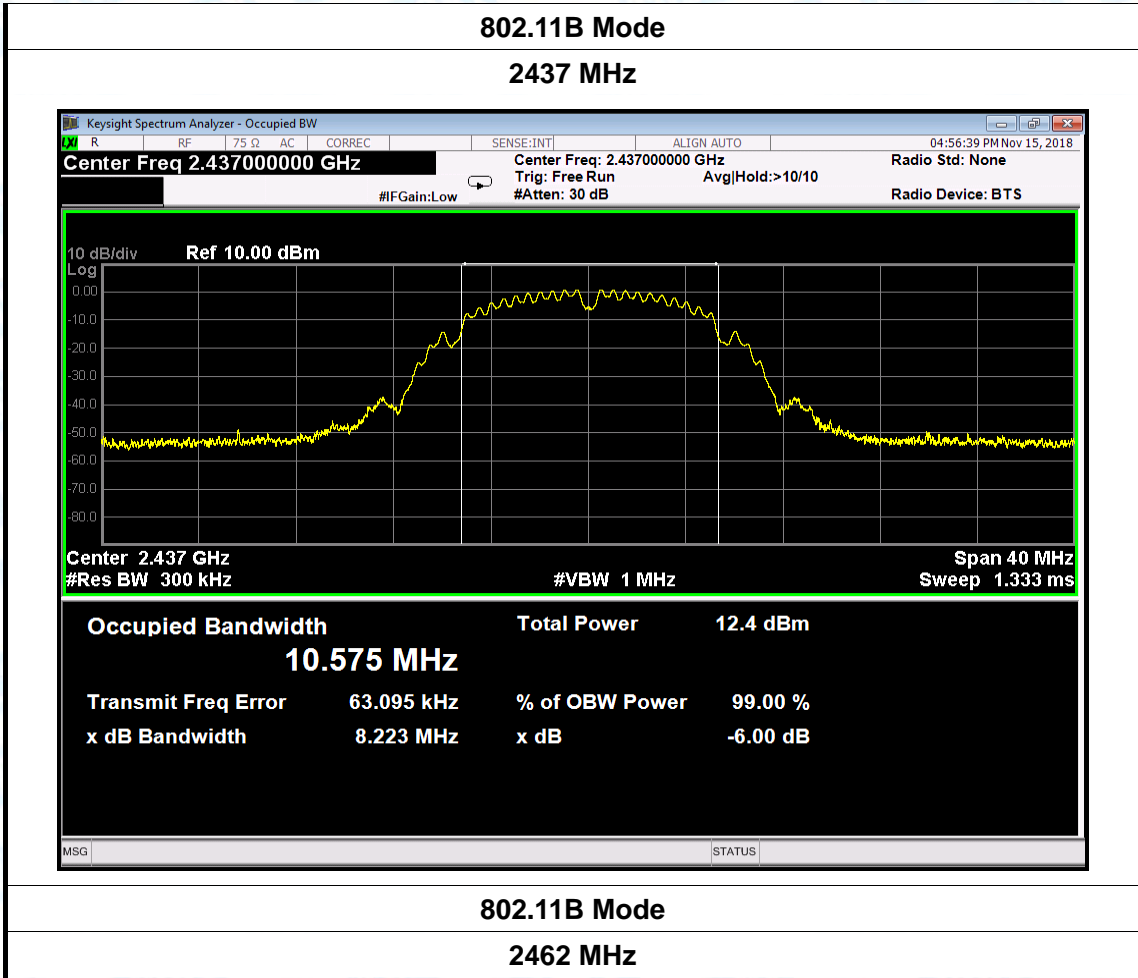



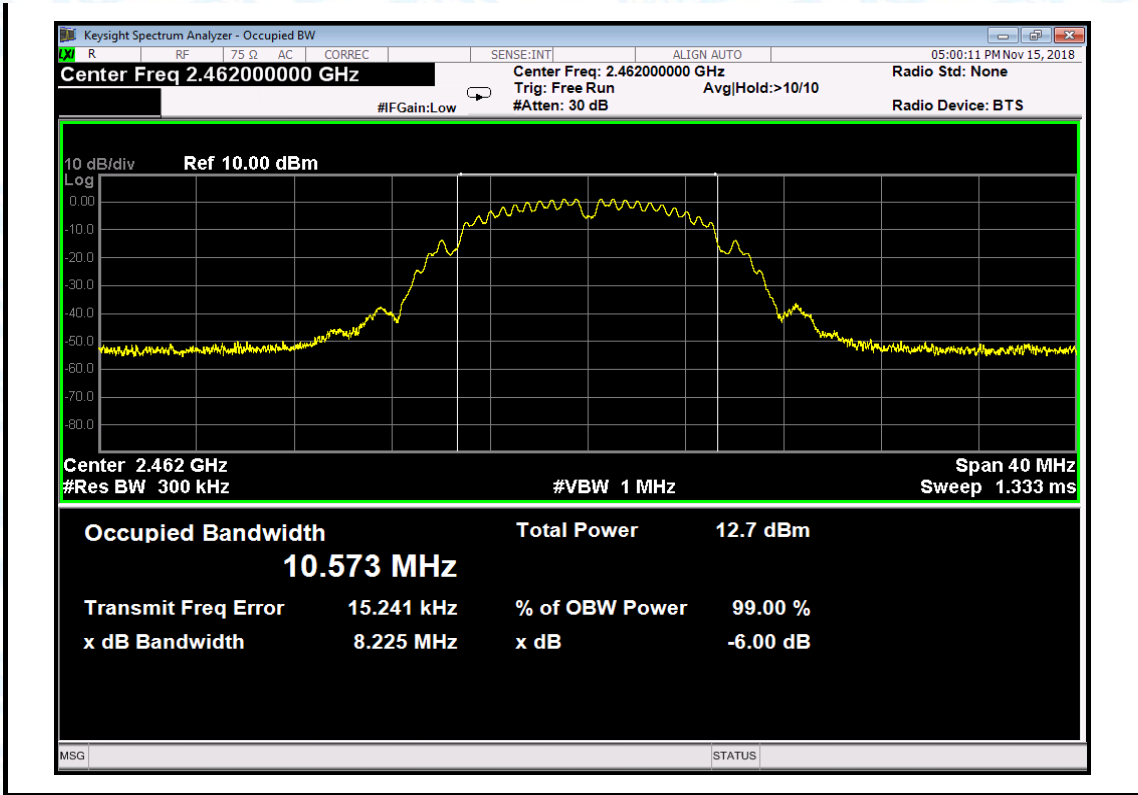

<b>Temperature:</b>	25 °C	<b>Relative Humidity:</b>	55%
<b>Test Voltage:</b>	AC 120V/60HZ		
<b>Test Mode:</b>	TX 802.11G Mode		
Channel frequency (MHz)	6dB Bandwidth (MHz)	99% Bandwidth (MHz)	Limit (MHz)
2412	16.52	16.895	>=0.5
2437	16.51	16.912	
2462	16.52	16.931	

**802.11G Mode**

**2412 MHz**

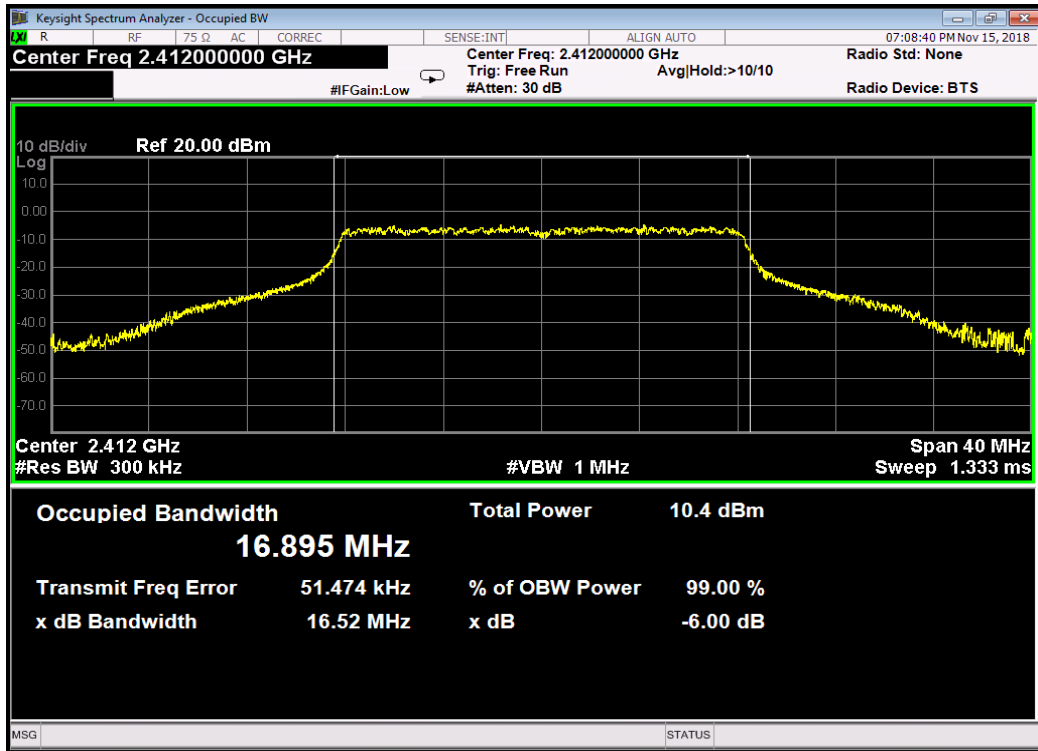



802.11G Mode

2437 MHz

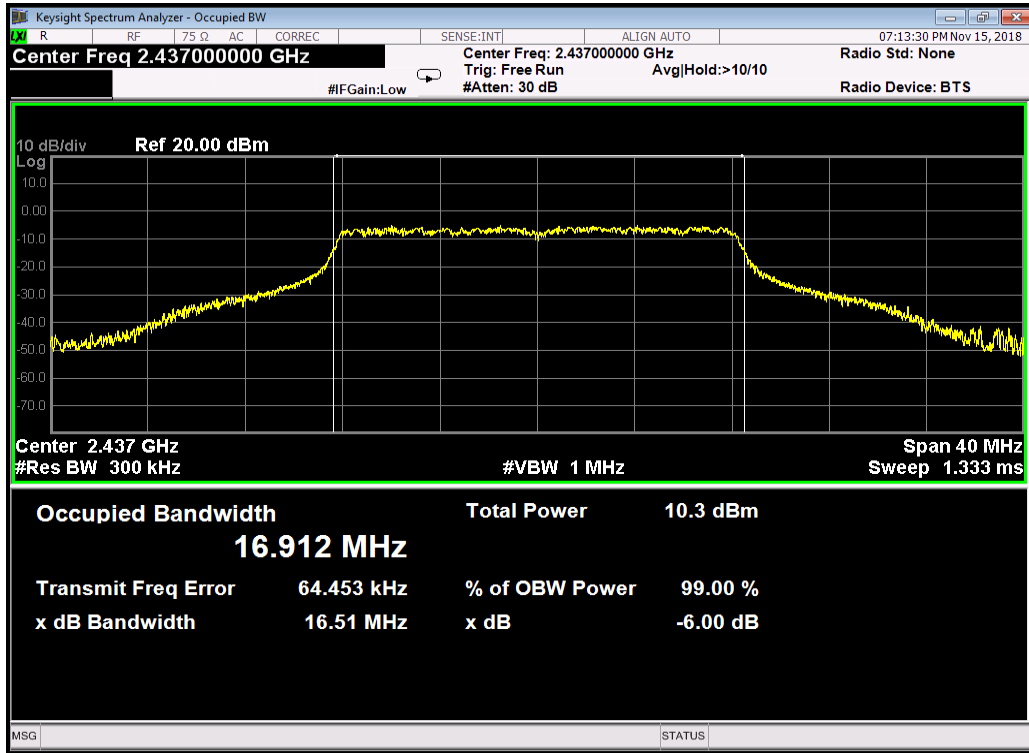

802.11G Mode

2462 MHz

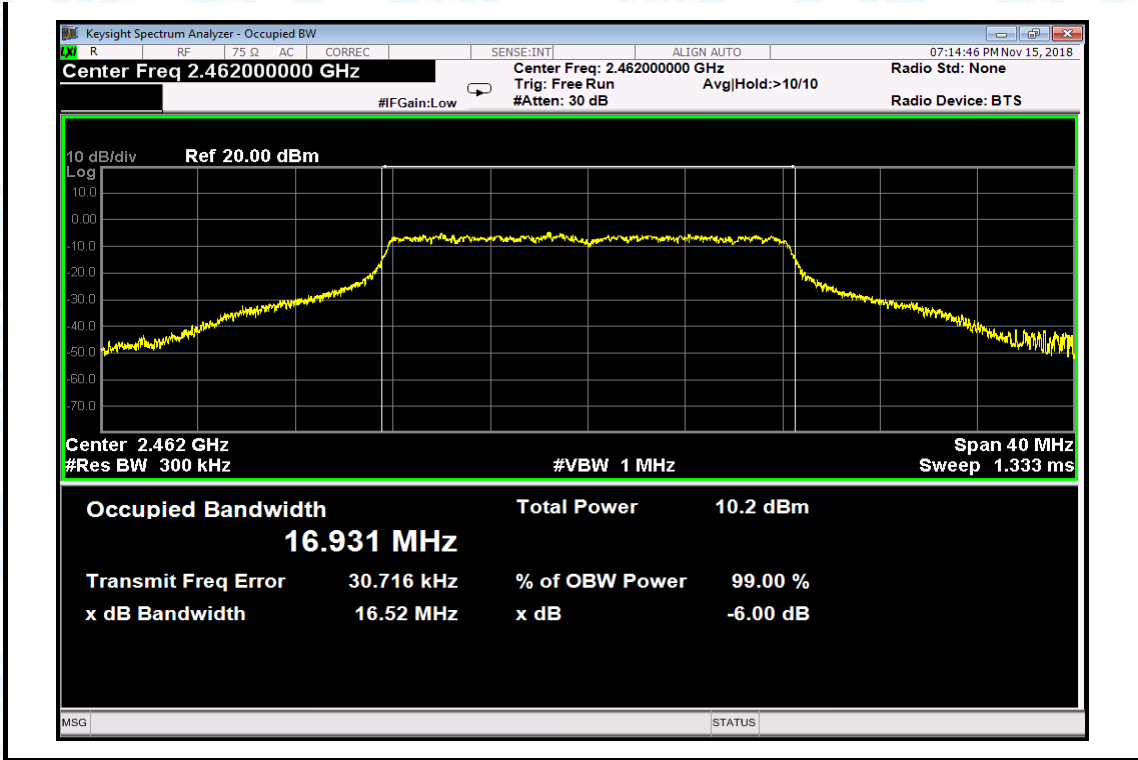



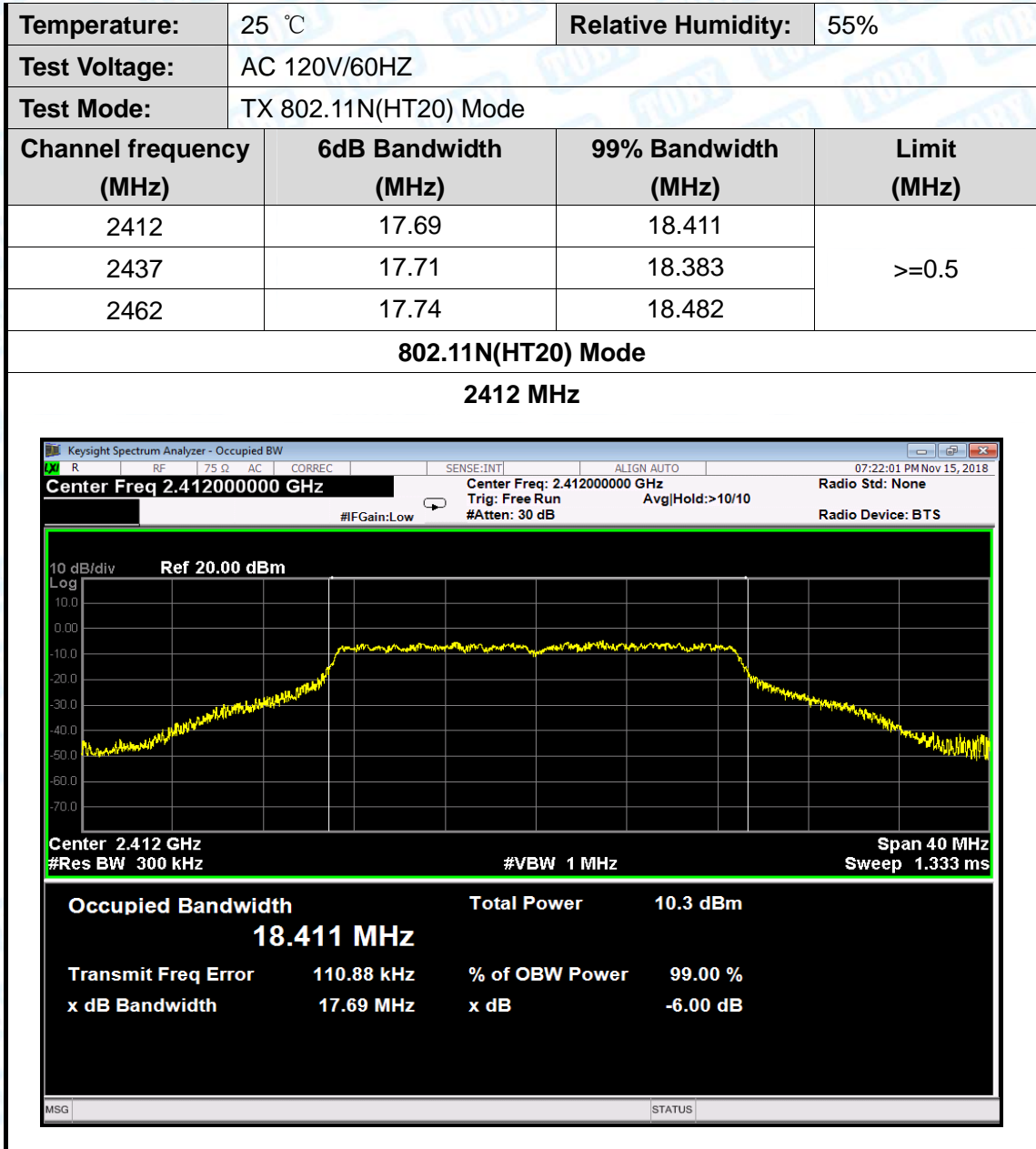

**802.11N(HT20) Mode**

**2437 MHz**

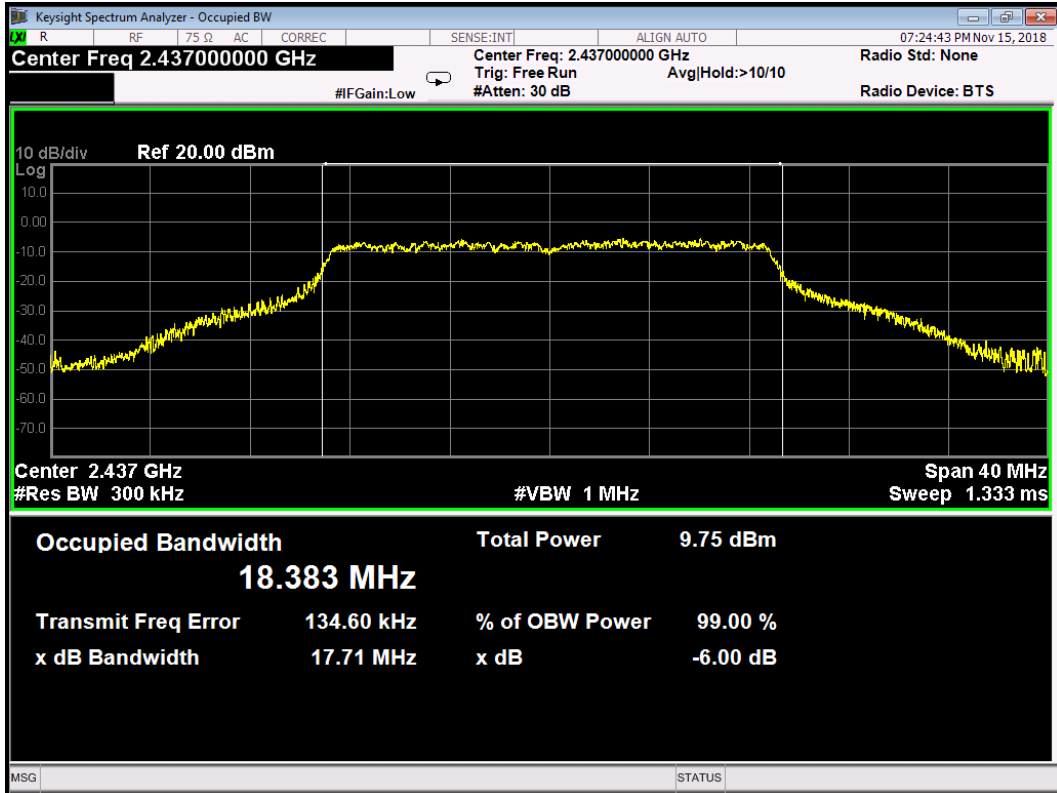

**802.11N(HT20) Mode**

**2462 MHz**



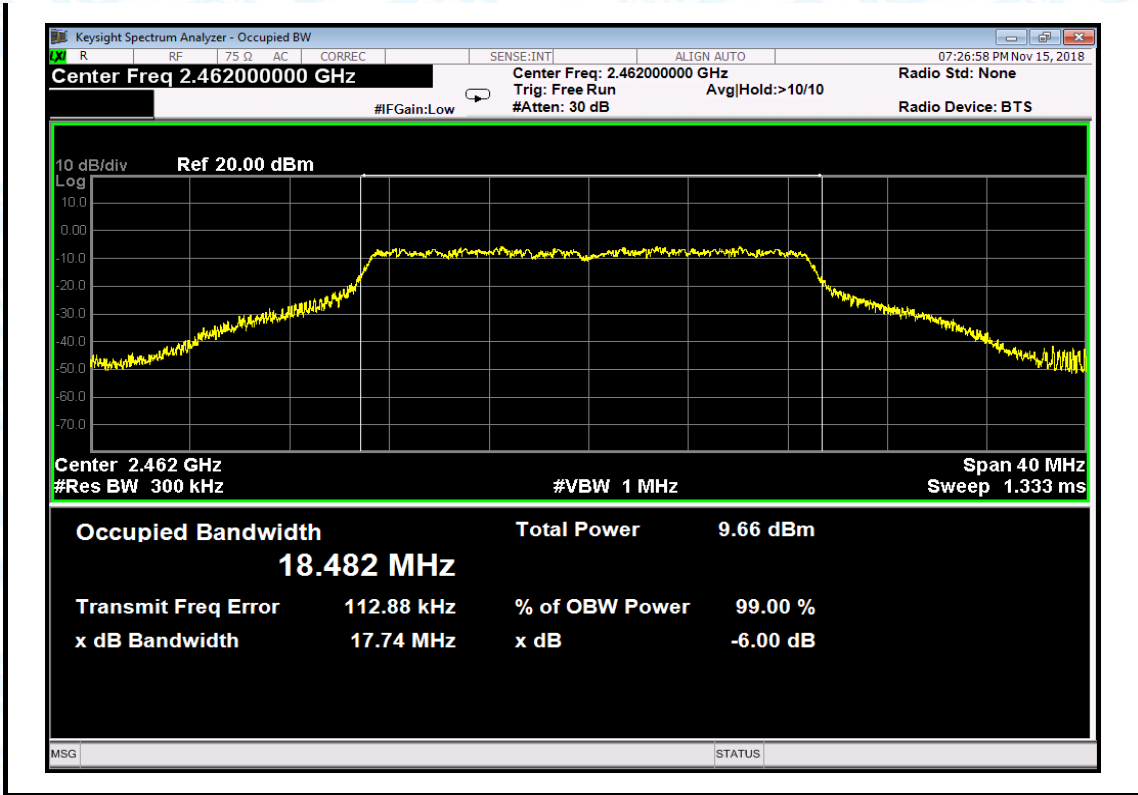

### Attachment E-- Peak Output Power Test Data

<b>Test Conditions:</b>		Continuous transmitting Mode	
<b>Temperature:</b>		25 °C	<b>Relative Humidity:</b> 55%
<b>Test Voltage:</b>		AC 120V/60HZ	
Mode	Channel frequency (MHz)	Test Result (dBm)	Limit (dBm)
802.11b	2412	14.65	30
	2437	14.08	
	2462	14.27	
802.11g	2412	13.86	
	2437	13.37	
	2462	13.25	
802.11n (HT20)	2412	12.91	
	2437	12.70	
	2462	12.65	
<b>Result: PASS</b>			

Duty Cycle		
Mode	Channel frequency (MHz)	Test Result
802.11b	2412	>98%
	2437	
	2462	
802.11g	2412	
	2437	
	2462	
802.11n (HT20)	2412	
	2437	
	2462	

Please see below plots



802.11 B Mode 2437 MHz

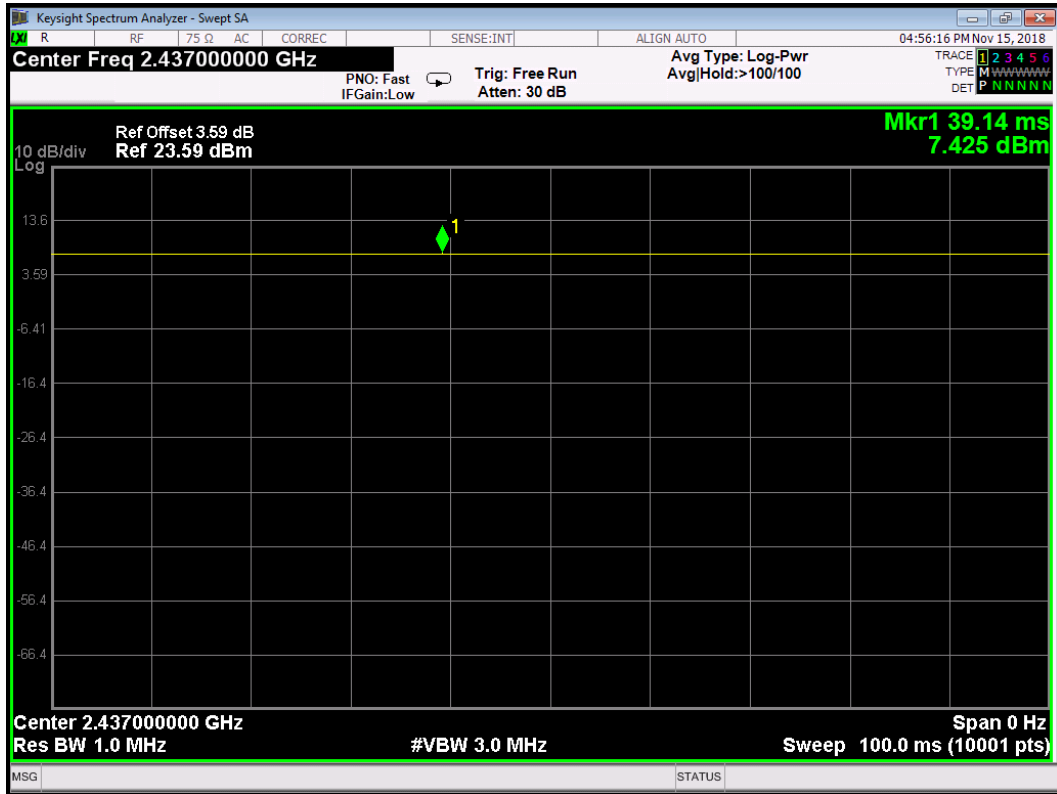

802.11 G Mode 2437 MHz

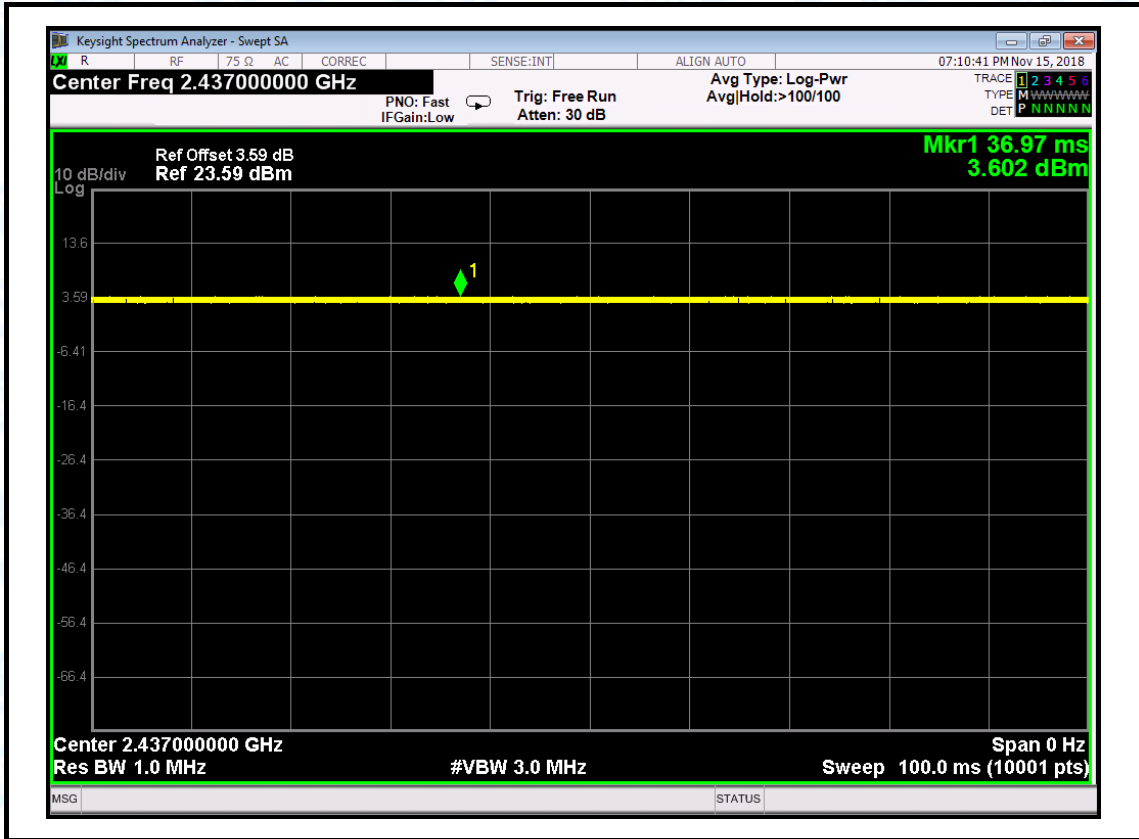



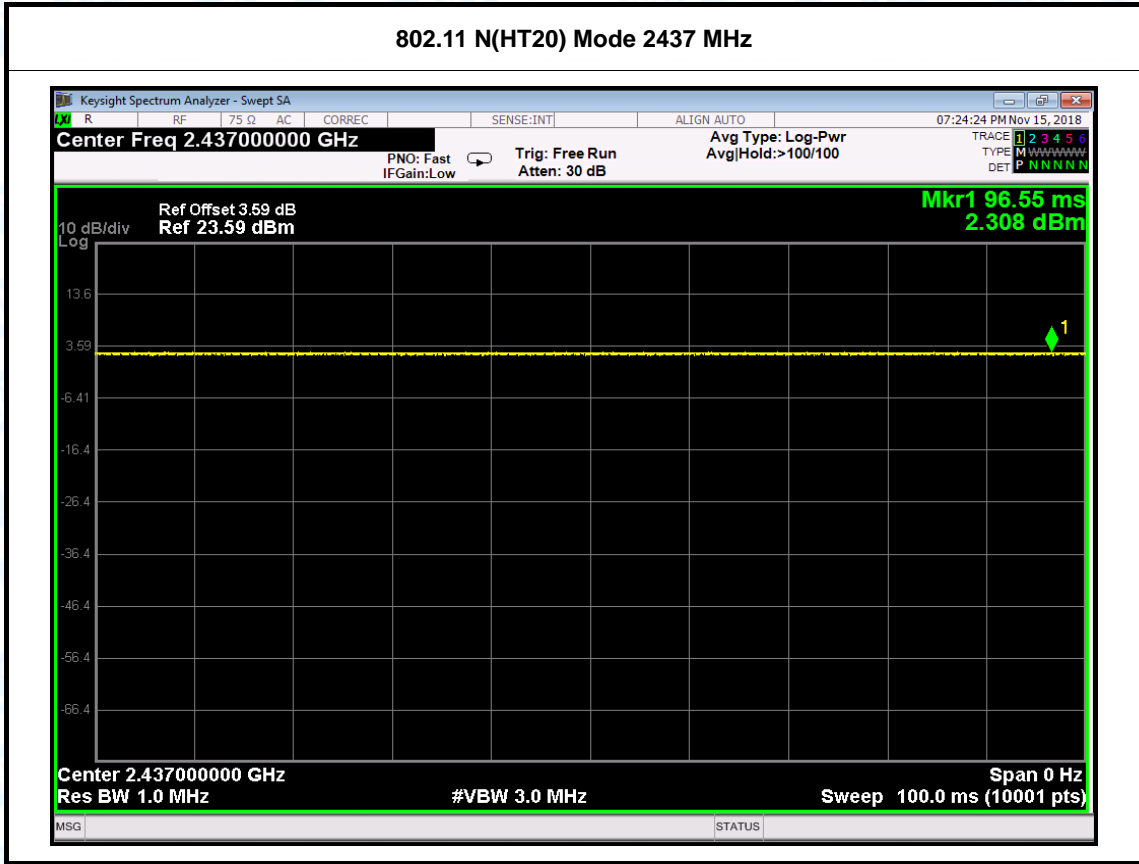

### Attachment F-- Power Spectral Density Test Data

Temperature:	25 °C	Relative Humidity:	55%
Test Voltage:	AC 120V/60HZ		
Test Mode:	TX 802.11B Mode		
Channel Frequency (MHz)	Power Density (dBm/3 kHz)	Limit (dBm/3kHz)	
2412	-10.891	8	
2437	-11.361		
2462	-11.215		

802.11B Mode

2412 MHz

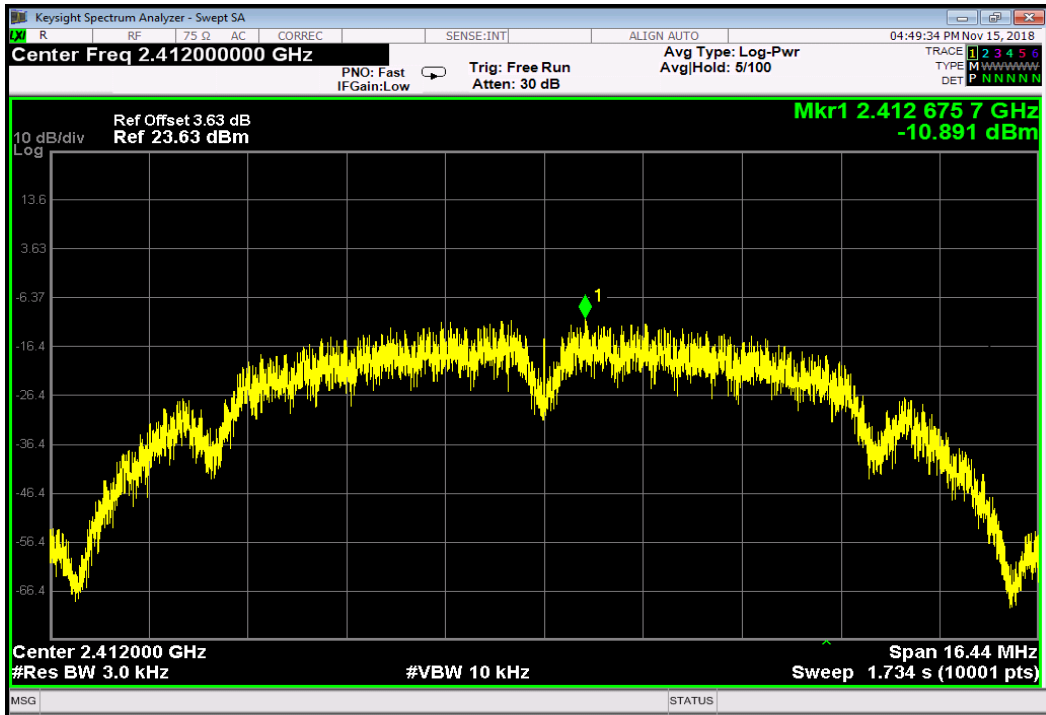



802.11B Mode

2437 MHz

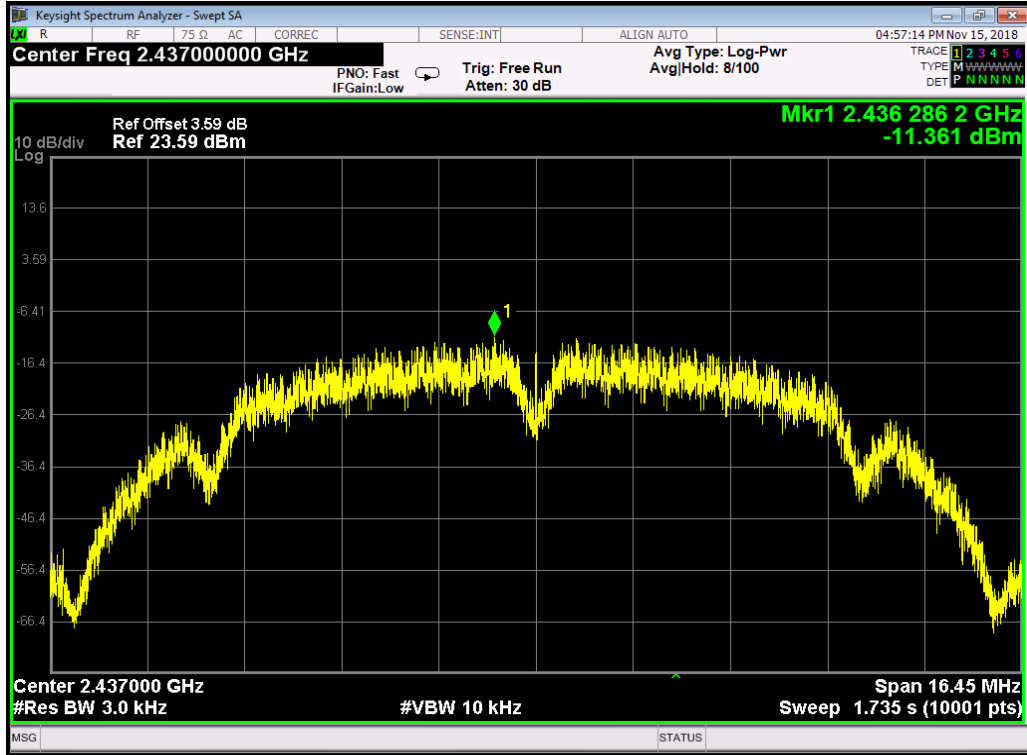

802.11B Mode

2462 MHz

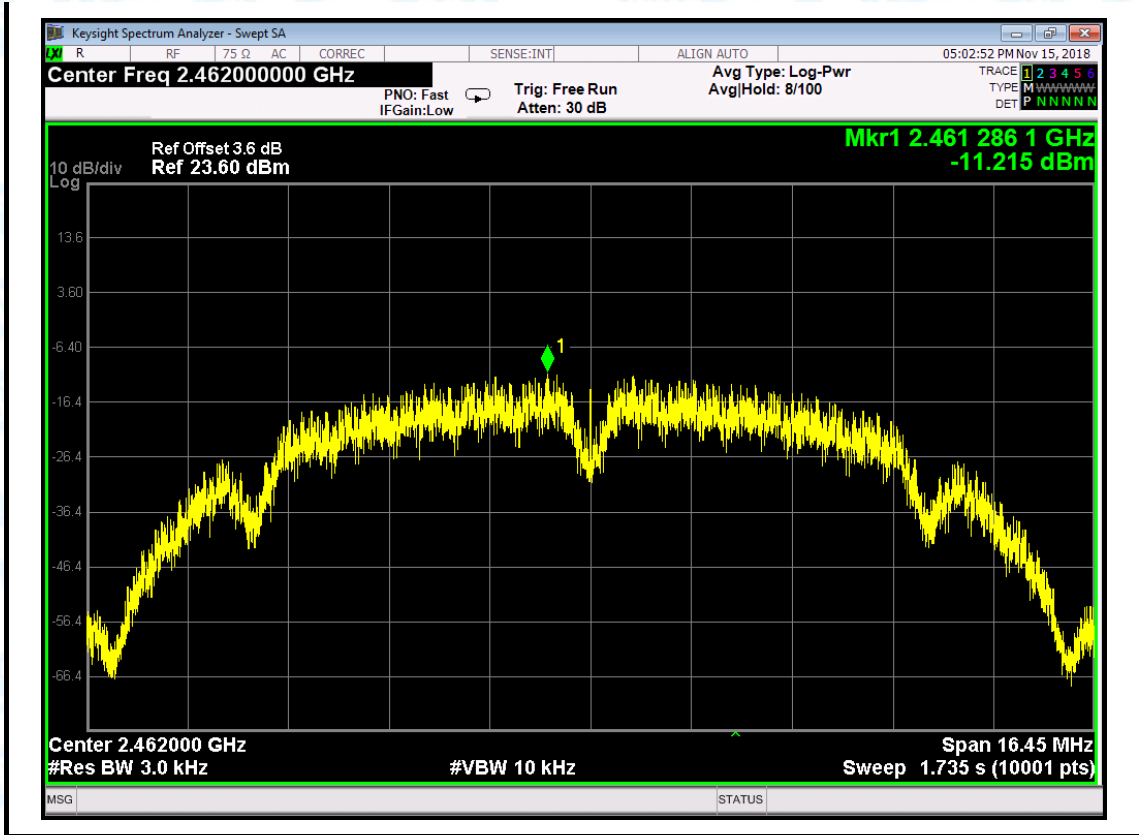



Temperature:	25 °C	Temperature:	25 °C
Test Voltage:	AC 120V/60HZ		
Test Mode:	TX 802.11G Mode		
Channel Frequency (MHz)	Power Density (dBm/3 kHz)	Limit (dBm/3kHz)	
2412	-17.610	8	
2437	-17.583		
2462	-17.246		

**802.11G Mode**

**2412 MHz**

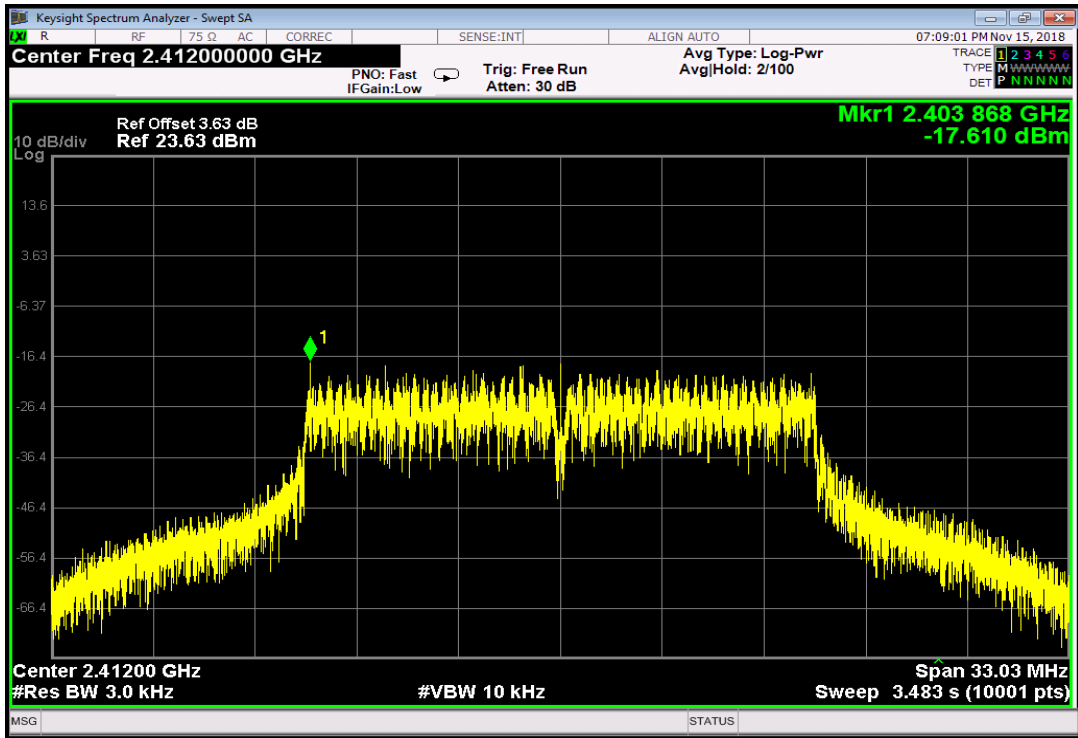

802.11G Mode

2437 MHz

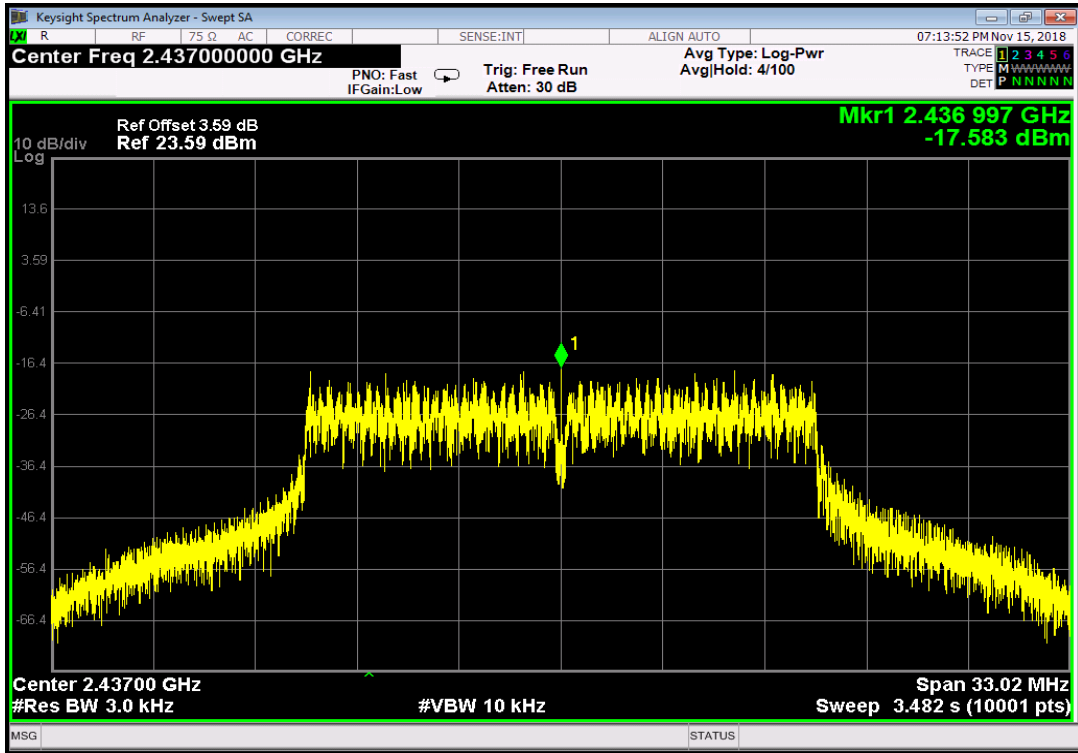

802.11G Mode

2462 MHz



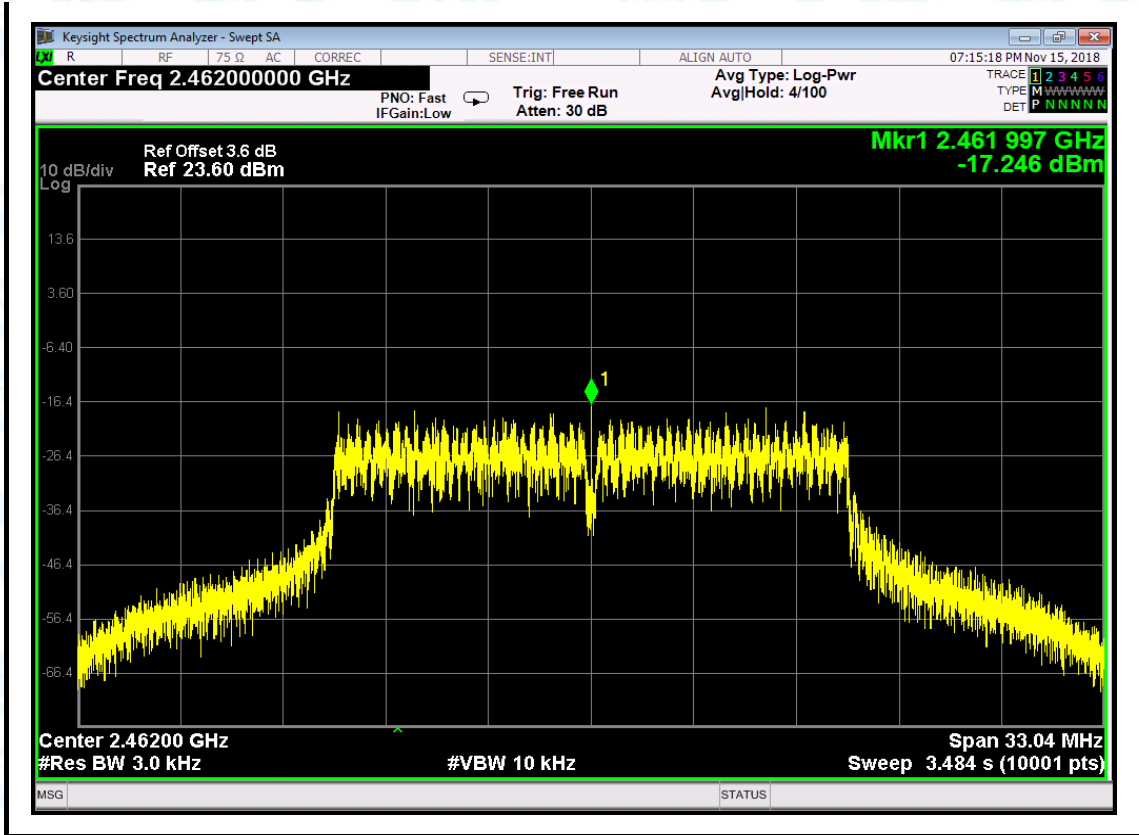

Temperature:	25 °C	Temperature:	25 °C
Test Voltage:	AC 120V/60HZ		
Test Mode:	TX 802.11N(HT20) Mode		
Channel Frequency (MHz)	Power Density (dBm/3 kHz)	Limit (dBm/3kHz)	
2412	-18.619	8	
2437	-17.821		
2462	-18.035		

**802.11N(HT20) Mode**

**2412 MHz**

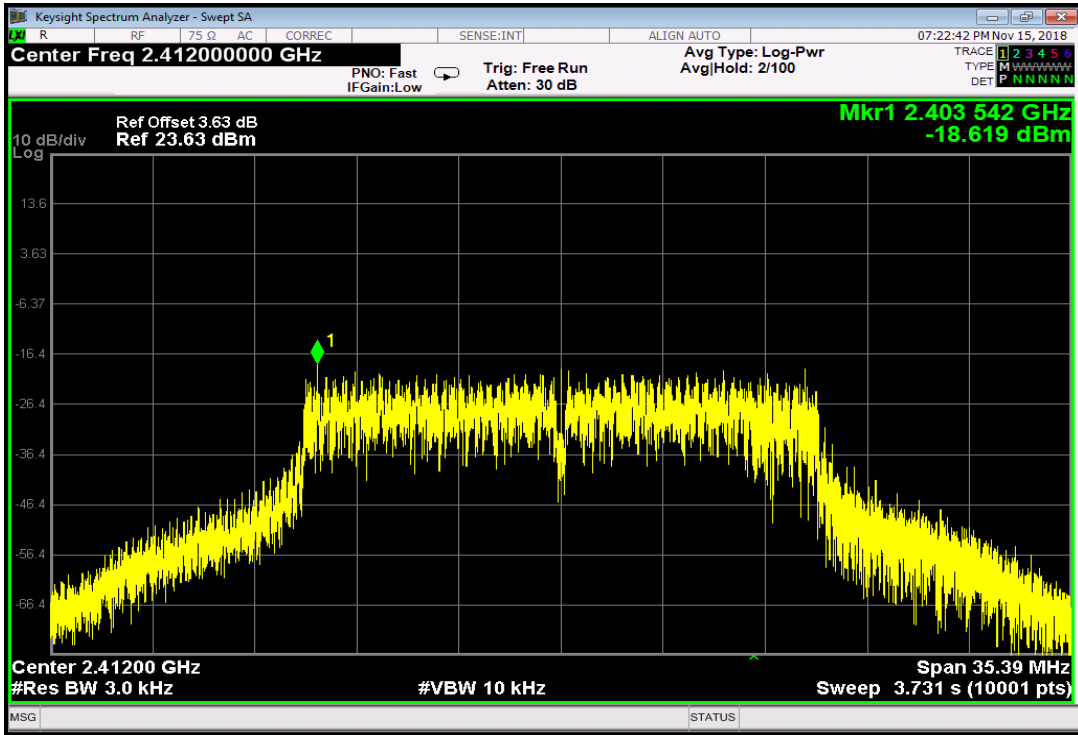



**802.11N(HT20) Mode**

**2437 MHz**

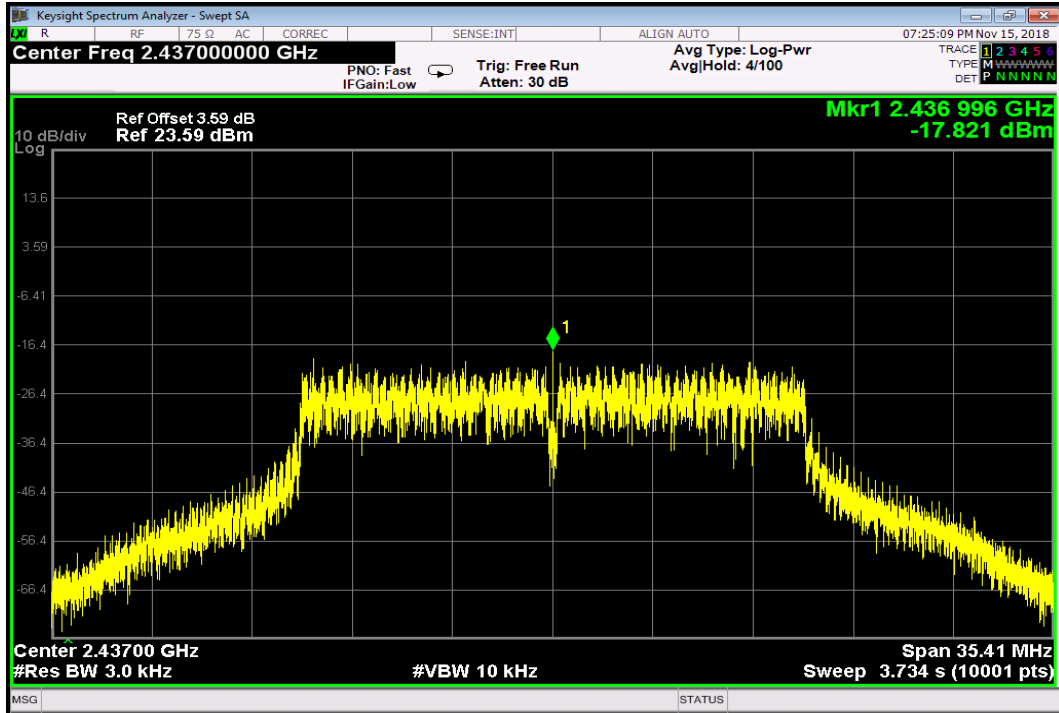

**802.11N(HT20) Mode**

**2462 MHz**

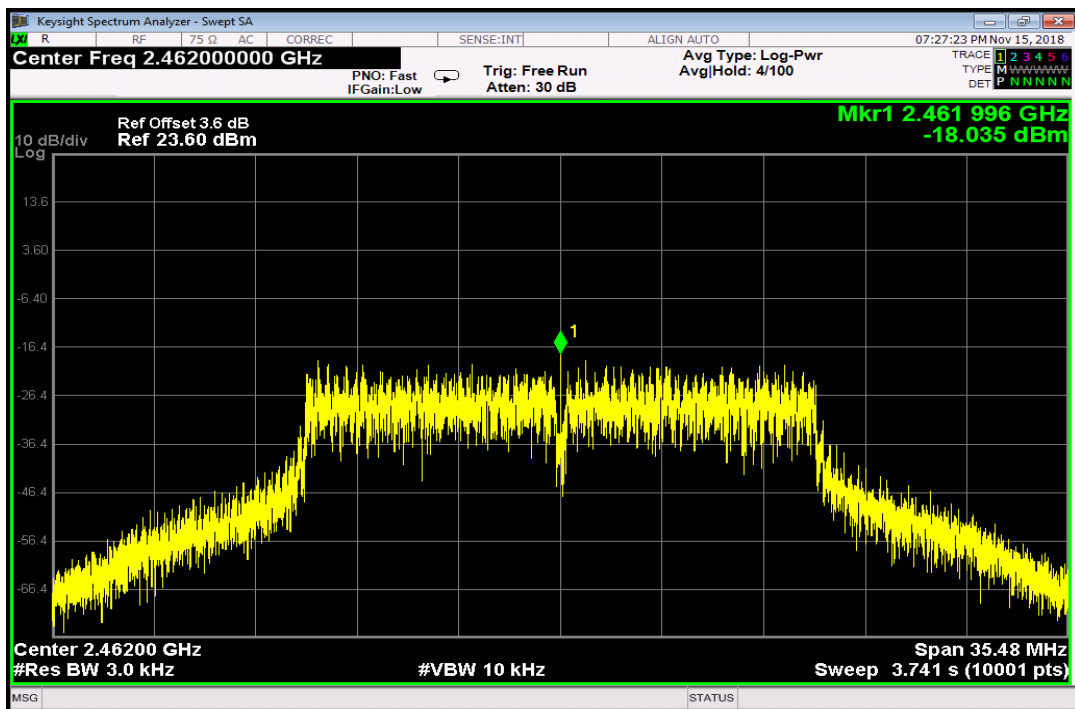

-----END OF REPORT-----